

This work has been submitted to the IEEE for possible publication. Copyright may be transferred without notice, after which this version may no longer be accessible.

Next Generation Backscatter Communication: Theory and Applications

Wanchun Liu, Kaibin Huang, Xiangyun Zhou and Salman Durrani

Abstract

The Internet-of-Things (IoT) is an emerging concept of network connectivity anytime and anywhere for billions of everyday objects, which has recently attracted tremendous attention from both the industry and academia. The rapid growth of IoT has been driven by recent advancements in consumer electronics, wireless network densification, 5G communication technologies, and cloud-computing enabled big-data analytics. One of the key challenges for IoT is the limited network lifetime due to massive IoT devices being powered by batteries with finite capacities. The low-power and low-complexity backscatter communications (BackCom), which simply relies on passive reflecting and modulation an incident radio-frequency (RF) wave, has emerged to be a promising technology for tackling this challenge. However, the contemporary BackCom has several major limitations, such as short transmission range, low data rate and uni-directional information transmission. In this article, we present an overview of the next generation BackCom by discussing basic principles, system and network architectures and relevant techniques. Lastly, we describe the IoT application scenarios with the next generation BackCom.

I. INTRODUCTION

The idea of *Internet-of-Things* (IoT) originated from an Internet-connected Coke machine at Carnegie Mellon University in the 1980's and took over in the late 1990's with the vision of networking everyday objects so as to automate our societies and daily lives. In the past decades, the IoT has seen technological innovations in a wide range of applications such as smart city, smart home, and autonomous robots, vehicles and *unmanned aerial vehicles* (UAVs). The IoT is expected to comprise tens of billions of sensors in the near future among other types of nodes. The Big-Data collected via the sensors over IoT is centralized and analyzed in

Wanchun Liu is with School of Electrical and Information Engineering, The University of Sydney, NSW 2006 (email: wanchun.liu@sydney.edu.au). Kaibin Huang is with the Dept. of Electrical and Electronic Engineering, The University of Hong Kong, Hong Kong (email: huangkb@eee.hku.hk). Xiangyun Zhou and Salman Durrani are with Research School of Engineering, The Australian National University, Canberra, ACT 2601, Australia (emails: {xiangyun.zhou, salman.durrani}@anu.edu.au).

the Cloud to measure and regulate phenomena of common interest in the real world such as pollution, traffic congestion, and parking availability. Empowered by cloud computing, the IoT technologies can penetrate many sectors of our society ranging from traffic control to business and foster breakthroughs in diversified fields ranging from physics to biology. However, keeping the massive number of energy-constrained IoT sensors alive poses a key design challenge for IoT. This is especially challenging given a large number of the sensors are hidden (e.g., in the walls or appliances) or deployed in remote or hazardous environments (e.g., in radioactive areas or pressurized pipes), making battery recharging or replacement difficult if not impossible. Thus, it is highly desirable to power IoT nodes by ambient energy harvesting [1] or wireless *power transfer* (PT) [2]. One particular promising solution in this regard is *backscatter communications* (BackCom) which allows an IoT node to transmit data by reflecting and modulating an incident RF wave [3]. The conventional radio architecture comprises power-hungry RF chains having oscillators, mixers and digital-to-analog converters, which results in non-compact form factors and limits the battery life of IoT devices. For example, the well-adopted RF chip CC2520 from Texas Instruments consumes about 100 mW for transmission, which is quite a large power consumption. In contrast, a backscatter node has no active RF components and as a result can be made to have miniature hardware with extremely low power consumption, e.g., in the order of 10 μ W [4], facilitating large-scale deployment at a flexible location or even in-body implantation.

In the past two decades, point-to-point BackCom has been widely deployed in the application of *radio-frequency identification* (RFID) for a passive RFID Tag to report an ID to an enquiring Reader over the near field (typically several centimeters). In its early stage, IoT comprised of primarily RFID devices for logistics and inventory management. However, IoT is expected to connect tens of billions of devices and accomplish much more sophisticated and versatile tasks with city-wise or even global-scale influences. *This demands the communication capabilities and ranges (tens of meters) between IoT nodes to be way beyond the primitive RFID operations supporting bursty and low-rate (several-bytes pre-written ID sequence) uni-directional transmission over several meters.* This can be achieved via a full-fledged BackCom theory leveraging the existing well-developed communication technologies such as small-cell networks, full-duplexing, multi-antenna communications and wireless PT, as well as advancements in electronics such as miniature radios (e.g., button-size radios) and low-power electronics. *Furthermore, instead of supporting a single RFID link, a BackCom networking theory has to be developed to support multiple access by a massive number of simultaneous IoT nodes.* From the computing perspective,

it is desirable for IoT sensors to pre-process sensing data to reduce its redundancy and latency while RFID Tags have no such capabilities. Despite the constraint on their form factors, IoT sensors can acquire powerful computing capabilities leveraging the advancements in miniature computers e.g., computer on a stick. These IoT design challenges present many promising research opportunities, resulting in a recent surge in research interests in BackCom.

This article aims at introducing the recent advances in the active area of BackCom. First, we summarize the basic principles, system and network architectures for BackCom. Second, we discuss how specific communication techniques have been redesigned for BackCom. Last, we focus on the applications of BackCom for IoT.

II. BACKCOM BASIC PRINCIPLES AND DESIGN TRADEOFFS

A. Mobile Architecture for BackCom

A basic BackCom system consists of two devices: a mobile backscatter node, i.e., a Tag, and a Reader [3]. The Tag is a passive node that harvests energy from an incident single-tone sinusoidal *continuous wave* (CW) radiated by the Reader, and also modulates and reflects a fraction of the wave back to the Reader. Specifically, the wave reflection is due to an intentional mismatch between the antenna and load impedance. Varying the load impedance makes the reflection coefficient to vary following a random sequence that modulates the reflected wave with Tag's information bits. Such a modulation scheme is named as the backscatter modulation. Therefore, the passive Tag is powered by RF energy harvesting and does not require any active RF component. On the contrary, the Reader has its own power supply and a full set of conventional RF components for emitting CW and information transmission/reception.

The mobile architecture of the Tag consists of an RF energy harvesting block, a battery, a modulation block and an information decoder, as illustrated in Fig. 1. The incident CW is connected to the RF energy harvesting block and either the modulation block or the information decoder depending on the transmission or reception mode of the Tag. The RF energy harvesting block converts the CW into a direct current (DC) signal to charge the battery. Powered by the battery, the key functional blocks, i.e., the modulation block and the information decoder, are able to perform backscatter modulation-based information transmission (IT) and energy detection-based information detection, respectively.

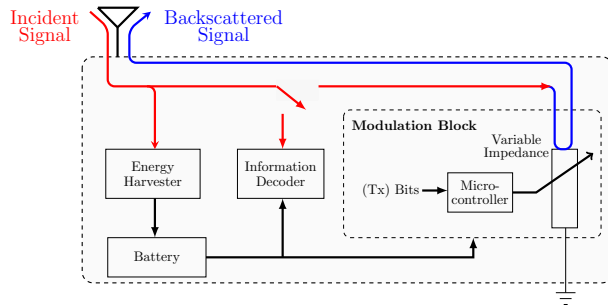

Fig. 1 The architecture of a backscatter Tag.

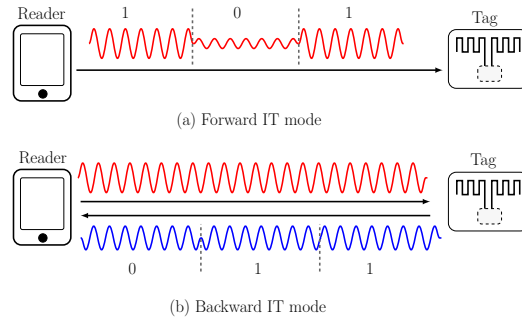

Fig. 2 The operation modes of a BackCom link: (a) forward and (b) backward information transfer (IT).

B. BackCom Modes and Modulation

In general, the communication between the Reader and the Tag has two modes: the forward IT, i.e., the Reader-to-Tag transmission, and the backward IT, i.e., the Tag-to-Reader transmission.

For the forward IT, as illustrated in Fig. 2(a), the Reader transmits a binary intensity modulated signal to the Tag. The Tag connects its information decoder and utilizes the received RF signal for RF energy harvesting and energy-detection based demodulation. For example, the decoded bit is ‘1’ or ‘0’ when a high or a low signal energy is detected, respectively. The use of this primitive on/off modulation and energy detection is due to the constraint that a typical Tag is provisioned with an energy detector instead of a power hungry RF chain needed for coherent demodulation.

For the backward IT, the Reader sends a CW signal to the Tag, and the Tag connects its modulation block and utilizes the received RF signal for RF energy harvesting and backscatter modulation. Generally, a Tag can modulate the reflected signal by switching over a given set of impedances, generating a set of reflection coefficients forming a constellation. For example, assuming *binary phase-shift keying* (BPSK) modulation, as illustrated in Fig. 2(b), the Tag has a pair of impedances corresponding to two symbols, and it chooses either one of them for backscattering depending on the value of the transmitted bit.

For backward-IT modulation, one unique design issue is the consideration of energy-harvesting efficiency. Specifically, it is desirable to design a modulation scheme for BackCom that reduces the reflected energy and thereby increases the harvested energy. In general, the objective can be achieved by shifting the constellation points on the complex plane towards the original [3]. This, however, may increase the detection error-rate, introducing an energy-rate tradeoff.

The backward IT is the dominant mode for most of the conventional RFID applications, which

have asymmetric data traffics, e.g., a low-rate command through the forward IT and a high-rate information-bearing data through the backward IT. However, the forward and backward IT are equally important for future IoT applications, which require peer-to-peer network architecture and symmetric communication links between the massive number of devices.

C. Energy-Rate Tradeoff

Besides the said tradeoff arising from modulation design, there exists another one due to bursty transmission by IoT devices. For instance, a sensor for crowd-sensing reports data only upon receiving a query and spends the remaining time on other activities e.g., sensing and computing. Leveraging this characteristic, a backscatter Tag can be designed to periodically switch between two modes, namely the *silent* (or energy harvesting) and *active* modes. Then the *duty cycle* is defined as the percentage of time for the active mode. In the silent mode, the energy of the incident wave is fully harvested without reflection, by matching the variable impedance to that of the antenna, and the circuit may be turned off for energy conservation. In the active mode, the Tag circuit is activated to receive or transmit data by backscattering where only the fraction of harvested energy is much smaller (see Fig. 1). Consequently, the duty-cycle is a key design parameter for regulating an energy-rate tradeoff.

III. BACKCOM SYSTEM AND NETWORK ARCHITECTURES

The conventional BackCom system discussed in Sec. II is the simplest BackCom system, as illustrated in Fig. 3(a). The BackCom systems for IoT are much more complex and can be divided into the following categories.

A. Multiple-Access BackCom Systems

Many real-life applications can be modeled as a *multiple-access* (MAC) BackCom system where a single Reader serves multiple Tags, as illustrated in Fig. 3(b). For instance, in a warehouse, an administrator can use a single Reader to collect information simultaneously from hundreds to thousands of items equipped with RFID Tags. In a smart city, a data aggregator can receive sensing data from a large number of backscatter sensors at the same time.

The efficiency of the MAC BackCom system can be improved by avoiding collisions between multi-Tag transmissions using the traditional MAC schemes including *space/frequency/code/time-division multiple-access* (SDMA/FDMA/CDMA/TDMA), see [5]. The other scheme, *orthogonal*

frequency-division multiple-access (OFDMA), may not be suitable as the required FFT operation is too complex for backscatter nodes. Due to its simplicity, TDMA is perhaps the most practical scheme for MAC BackCom systems where Tags transmit in separate pre-assigned time slots in each frame. The inherent closed-loop signaling for BackCom facilitates the needed Reader-Tag synchronization for TDMA. Researchers have also attempted to design new MAC schemes exploiting the characteristics of BackCom. For instance, an interesting new method for collision avoidance was proposed in [6] for MAC BackCom that treats bursty backscatter transmissions by Tags as a sparse code and decodes multi-Tag data at the Reader using a compressive-sensing algorithm.

B. BackCom Interference Systems

To avoid unnecessarily overloading the core network and reduce latency, distributed *device-to-device* (D2D) communications are common in IoT, creating BackCom interference channels. Compared with conventional interference channels, a backscatter node reflects all incident interference signals, resulting in *interference regeneration*. The phenomenon is illustrated in Fig. 3(c) showing a two-link BackCom interference channel where Readers 1 and 2 each transmit a CW to backscatter Tags 1 and 2, respectively. In total, each Reader, e.g. Reader 1, is exposed to two interference components due to Tag 2's modulation and reflection of CWs from Readers 1 and 2. In theory, the number of interference components received by each Reader can increase as the square of the number of coexisting links instead of linearly with the number in the conventional case. As a result, the interference issue is particularly severe in BackCom interference networks due to interference regeneration. One effective way for coping with this issue is to adopt *spread spectrum* techniques in BackCom exploiting its low data rates [7].

C. RF Energy Harvesting BackCom Systems

Ultra-dense IoT nodes are expected to be deployed in the environment in the near future and communicate by D2D transmissions. Most transmitting nodes are energy constrained and cannot act as Readers to emit high-power CW and power their receivers nor to enable D2D transmissions. For IoT, there are two practical solutions for the power-source problem:

One solution is to deploy dense low-complexity and low-cost *power beacons* (PBs), stations dedicated for microwave power transfer (MPT) [2], to enable D2D BackCom links in their proximity by beaming towards them strong CWs, as illustrated in Fig. 3(d). Then the Tag is

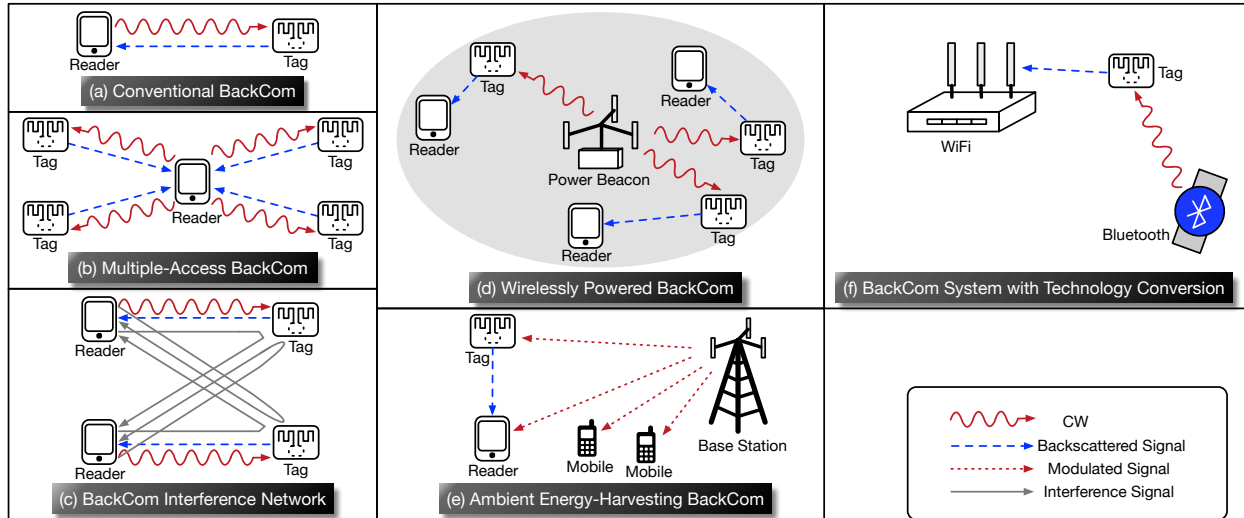

Fig. 3 BackCom system and network architectures.

able to perform RF energy harvesting and BackCom to the Reader. Such BackCom system is termed as *wirelessly powered BackCom*.

The other solution is to harvest the energy from ambient RF signals, such as the signals from cellular, TV broadcasting and WiFi networks. Leveraging the ambient RF signals can allow direct Tag-to-Reader (or D2D) communication without Readers supplying power, which has motivated various relevant designs recently [8]. For instance, a backscatter Tag can transmit data to a peer by reflecting an incident base-station signal, as illustrated in Fig. 3(e). Therefore, instead of having some specific PBs or Readers that enables tag-to-reader communications, the ambient backscatter system can use existing infrastructure and benefit from signals that are not intended for itself. Such an energy harvesting BackCom system differs from one with a Reader or PB in two important aspects. First, the CW is replaced with a modulated signal and thus the reflection is *double modulated* with superimposed unintended and intended data. This problem can be tackled by exploiting the asymmetry in the high-rate ambient and low-rate backscatter signals. As result, the latter can be detected after suppressing the former by time averaging over each symbol duration. The second issue is the incident ambient signal is much weaker than the CW from an intended Reader or PB due to a much long propagation distance. Consequently, BackCom with ambient RF signal is suitable only for either short-distance or infrequent D2D communications.

D. BackCom Systems with Technology Conversion

To communicate with passive Tags embedded with different types of available commercialized devices, BackCom systems with technology conversion come into being.

One technology conversion is to leverage a Bluetooth signal for BackCom between a Tag and a WiFi device [9], as illustrated in Fig. 3(f). Consider a wearable-device network, which consists of an implanted BackCom sensor (i.e., a Tag), a Bluetooth watch, and a smart phone, which is a WiFi device. The Bluetooth watch adopts a *Gaussian Frequency Shift Keying* (GFSK) method that encodes bits using two frequency tones. Hence, the watch emits a CW at either of these frequency tones. By leveraging such CW-like Bluetooth signals, the BackCom Tag would like to get its sensed e-health information collected by the smart phone through backscatter modulation. Although the Bluetooth CW frequency is usually different from WiFi, by adopting a FSK modulation through properly switching between different impedances, the BackCom Tag is able to shift the Bluetooth CW to the WiFi channel, hence achieving the BackCom with the smart phone.

Next, consider a BackCom system for smart home applications, which consists of a WiFi *access point* (AP) and a backscatter IoT sensor. The AP transmits packets to the WiFi clients, such as laptops and smart phones, which is also received by the backscatter IoT sensor. Then the sensor is able to modulate its data on the unintended signal and backscatters the signal to the AP. The double modulated backscattered signal is used by the AP, which obtains the Tag's information by removing its own transmitted information. In this way, sensors can be powered by WiFi APs and also rely on them to access the Internet even in the presence of access by WiFi devices, thereby providing inter-connectivity of everything for smart homes.

E. Comparison with a Traditional System

To quantify the benefits for the IoT nodes with backscatter circuit, we simulate an IoT *wireless sensor network* (WSN), where each IoT sensor node adopts either a backscatter circuit or a traditional RF circuit (including a mixer, DAC, and amplifier). Both types of the nodes are powered by a PB. The IoT nodes with a density of 0.02 nodes/m^2 are randomly distributed in a disk region with the radius of 10 m and served by the PB at the center. Each node aims to perform sensing and transmission to its intended receiver at a fixed distance of 0.5 m. The IoT nodes adopt a harvesting-then-sensing-and-transmission task sequence per 100-ms time slot,

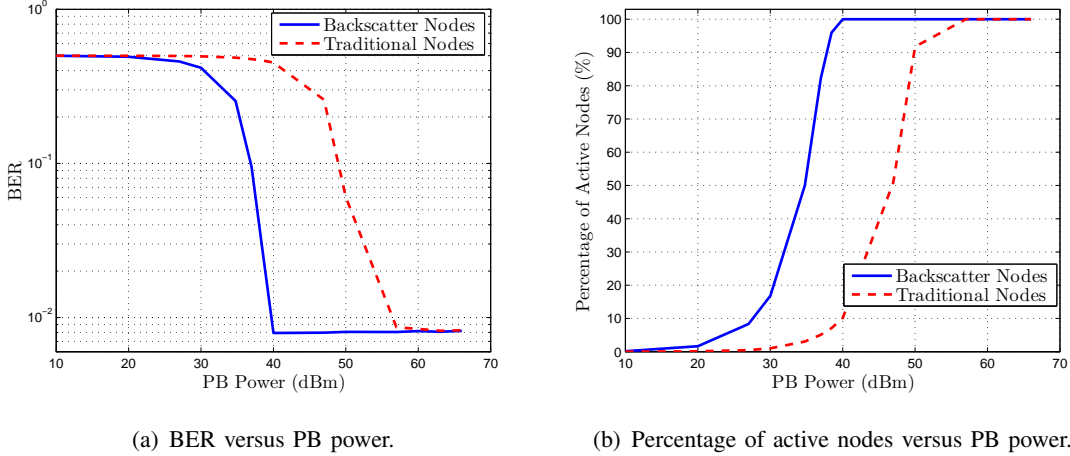

Fig. 4 Simulation results, where 10 – 50 dBm is a practical range of PB power.

where energy harvesting occupies 20 ms and the other operations 80 ms if there is sufficient energy.

The antenna effective apertures of all nodes are 0.001 m^2 . We consider Friis free-space channels for wireless power transfer and IT. The carrier frequency is 2.4 GHz, the modulation scheme BPSK, and the noise power at the receiver -100 dBm , and the RF energy harvesting efficiency 50%. Each sensing task consumes $0.1 \mu\text{J}$ of energy (e.g., ambient light sensor TSL2550D), and the digital circuit power consumption during the active mode is $2.5 \mu\text{W}$ [4]. Each BackCom IoT node does not perform RF energy harvesting while backscattering, i.e., with 100% reflection. For the traditional IoT node, the power consumptions of the mixer and DAC during active mode are $15 \mu\text{W}$ and 0.1 mW , respectively (e.g., mixer AD831 and DAC8830), and the power amplifier (class AB) works at an efficiency of 50%.

Based on these practical settings, we investigate how much performance improvement is achieved in the IoT network by adopting the backscatter circuit. Fig. 4(a) plots the average BER at the receiver versus the PB's transmit power. We see that the BERs with the two kinds of IoT nodes decrease inversely with the PB's transmit power and converge to the same value due to interference. Also, we see that the BER achieved by the backscatter nodes is significantly reduced compared with the traditional nodes within a practical range of PB's transmit power, e.g., the BER is reduced by 100 times when the PB has a 40 dBm transmission power. Fig. 4(b) plots the percentage of active nodes. We see that the percentage of active IoT nodes increases with the PB's transmit power, and the percentage of the active backscatter nodes is much larger than that of the traditional nodes. For example, the improvement of the percentage of active nodes

is 18% when the transmit power is 30 dBm, and the improvement is 90% when the transmit power is 40 dBm. Therefore, the simulation results clearly show that the backscatter nodes can significantly improve the performance of the IoT network.

IV. BACKCOM TECHNIQUES

The future IoT applications require the BackCom systems to enable far-distance, low-latency, and high-rate communications between dense IoT devices and also enable their ad hoc communication. A few advanced BackCom techniques aiming at tackling these challenges are discussed as follows.

A. Wirelessly Powered BackCom

Different from conventional RFID Tags which only need to report its ID information, the IoT BackCom Tags are also required to perform sensing and computing which consume much more energy. How to wirelessly power BackCom using PBs (see earlier discussions) and maximize the power-transfer efficiency is a significant design issue.

The efficiency can be increased by energy beamforming from a multi-antenna PB and a Tag. To this end, the PB needs to know the forward *channel state information* (CSI). For a free-space channel, the CSI reduces to the Tag direction with respect to the PB. The PB can form a beam using the well-known retrodirective beamforming technique that automatically generates a beamformer by conjugating the observation of the pilot signal sent (i.e., reflected) by the Tag. On the other hand, for a scattering channel, the beamformer designs are more complex but can exploit the so called “key-hole” channel structure due to backscattering (see e.g. [10]).

Another technique for improving the power-transfer efficiency is to optimize the CW waveform, e.g., as a weighted sum of multiple sinusoidal waves (see e.g., [11]). The design aims at increasing the peak-to-average power ratio of the PB signal that yields a higher energy-harvesting efficiency due to its non-linearity as a function of incident power.

B. Full-Duplex BackCom

For future IoT, there would be billions of D2D links existing at the same time. Though information flow in RFID applications is usually uni-directional, message exchange between nodes is common in IoT. Thus, full-duplex communication can substantially reduce latency and interference, and improve the efficiency of spectrum utilization of the IoT-D2D links.

There are two methods for implementing full-duplex BackCom. Both require a Reader to have a full-duplex antenna allowing simultaneous transmission and reception [12]. Consider simultaneous forward and backward IT in a BackCom system having one pair of Reader and Tag. Leveraging prior knowledge of forward information, the Reader can cancel it in the backward IT signal and thereby retrieve the backward information. While this method supports symmetric bidirectional data rates, the other exploits the rate asymmetry in data transfer (Tag to Reader) and control signaling (Reader to Tag). Specifically, the signals have different frequencies and can be decoupled by filtering or averaging [7].

C. Time-Hopping BackCom

As mentioned, interference in dense D2D IoT poses a key design challenge that is exacerbated by backscattering. Fortunately, a large population of IoT devices are sensors for smart cities and homes, and the burstiness in their transmissions can be exploited for tackling interference. A suitable transmission technique is *time-hopping spread spectrum* (TH-SS), where each Tag randomly selects one of N time slots for transmitting a single symbol and the choices of different Tags are independent [7]. As a result, the number of simultaneous links is reduced by the factor N , called the processing gain, thereby suppressing interference. An extreme form of TH-SS can be realized by *ultra-wideband* (UWB) transmission, where an extremely large processing gain is achieved using ultra-narrow pulses whose durations are in the order of nano-second [13].

D. MIMO BackCom

A key characteristic of the backward BackCom (i.e., the tag-to-reader information transmission) is the *double path-loss* due to the fact that the backscatter signal received at a Reader propagates through the closed-loop channel cascading the downlink and uplink channels. The resultant path loss is especially severe as the propagation distances in IoT are much longer than those for RFID applications. To enhance link reliability, one solution is to deploy antenna arrays at Readers and Tags and apply spatial-diversity techniques. Furthermore, multi-antennas can enhance the efficiency of wireless power transfer by enabling transmit energy beamforming and increasing receive antenna apertures.

Backscattering introduces a special channel structure for the backward IT in a *multiple-input-multiple-output* (MIMO) BackCom system, called a *dyadic MIMO channel*, which captures the composite fading in the forward and backward channels [3]. To be specific, the CW signals sent

by the transmit antennas of the Reader propagate through the forward MIMO channel, and are first combined at each antenna of the Tag and then backscattered, and lastly propagate through the backward MIMO channel to arrive at the receive antennas of the Reader. The resultant dyadic MIMO channel has a similar structure as the classic *keyhole MIMO channel*. The space-time coding is a simple but suitable technique for achieving the diversity gain of such a channel. By adopting space-time coding, it has been proved that the achievable maximum diversity order is equal to the number of the Tag's antennas [3]. In other words, in contrast to the conventional MIMO channel, increasing the number of receive antenna at the Reader cannot continuously enhance the reliability of the backward IT.

V. IOT APPLICATIONS FOR BACKCOM

A. *BackCom for Smart Homes/Cities*

Low-power or passive BackCom devices with energy harvesting capabilities can be densely deployed to provide pervasive and uninterrupted sensing and computing services that provide a platform for implementing applications for smart homes/cities.

In a smart home, a large number of passive BackCom sensors can be placed at flexible locations (e.g., embedded in walls, ceilings, and furniture). They are freed from the constraints due to recharging or battery replacements as one or multiple in-house PBs can be deployed to simultaneously power all the sensors or otherwise they can operate on ambient energy harvesting. The tasks performed by the sensors have a wide range such as detection of gas leak, smoke and CO, monitoring movements, indoor positioning, and surveillance [see Fig. 5(a)]. As an example, BackCom-based smart dustbins are able to monitor their trash levels and communicate the information to passing-by garbage trucks by backscattering, streamlining the trash-collection process. In another example, household robots are able to use the backscattered signals from the Tags located on doors and furniture for indoor navigation [14].

In a smart city, ubiquitous BackCom sensor nodes can be placed in every city corner such as buildings, bridges, trees, street lamps, and parking areas. They can streamline the city operations and improve our life quality via e.g., monitoring of air/noise pollution and traffic and parking-availability indicating. The efficient sensing-data fusion and wireless power for BackCom sensors can be realized by the deployment of integrated PBs and APs at fixed locations or mounted on autonomous ground vehicles or UAVs, providing full-city coverage without costly backhaul networks [15].

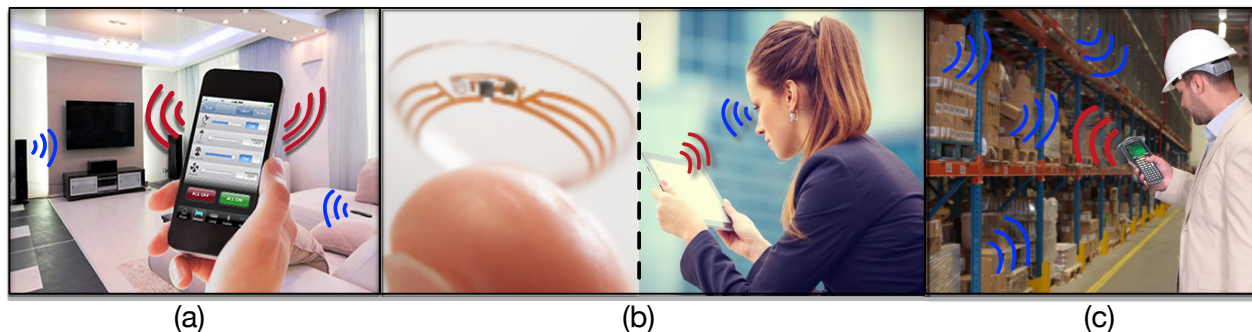

Fig. 5 BackCom applications: (a) Smart home, (b) smart contact lens and (c) logistics management.

B. BackCom for Biomedical Applications

IoT biomedical applications, such as plant/animal monitoring, wearable, and implantable human health monitoring, require tiny and low heat-radiation communication devices. BackCom devices, which do not rely on any active RF component, can meet such requirements and thereby avoid causing any significant effect on the plants, animals, tissues or organs being monitored. These advantages make BackCom a promising solution for IoT biomedical applications. One example is the BackCom-based smart Google Contact Lens, as illustrated in Fig. 5(b). The lens was invented in Google in 2014 for the purpose of assisting people with diabetes by constantly measuring the glucose levels in their tears (once per second). The device consists of a miniaturized glucose sensor and a tiny BackCom Tag. The Tag is able to provide energy to the sensor by RF energy harvesting from a wireless controller, and also backscatter the measured blood sugar level to the wireless controller for diagnosing purpose. Looking into the future, BackCom will find a wide range of biomedical applications. In particular, implantable tiny BackCom neural devices with ultra-low power consumption and heat radiation will be placed on the surface of the patient's brain to help the study, diagnosis and treatment of diseases such as epilepsy and Parkinson's disease, where the BackCom implants will act as the brain-computer interface.

C. BackCom for Logistics

Until now the most successful commercialization of the BackCom technique is the application in logistics due to the ultra-low manufacturing cost of simple and passive BackCom Tags, as illustrated in Fig. 5(c). The low-cost BackCom Tags make the commercialization easy and quickly. For example, as early as 2007, the biggest 100 suppliers of the global renowned chain

commercial group Wal-Mart have used the BackCom technology for logistics tracking. The technology has been helping the companies to substantially reduce operational cost, guarantee product quality, and accelerate the processing speed. In the past decade, the popularization and the application of BackCom have brought revolutionary changes to the logistics industry, due to its advantages compared with the conventional bar code technology, such as reduced manual control, long service lives, long reading distances, and encrypt-able and rewritable data.

In the future, apart from the existing BackCom techniques for logistics tracking and management, BackCom-based three-dimensional orientation tracking is an emerging technique. By attaching an array of low-cost passive BackCom Tags as orientation sensors on the surface of the target objects, three-dimensional orientation information is available at the Reader by analyzing the relative phase offset between different Tags. In this way, human workers can be warned when the angle of a cargo is larger than a threshold.

VI. CONCLUDING REMARKS

IoT that aims to enable both the activity and the connectivity of billions of energy-consuming smart nodes, is challenged from the energy perspective. The BackCom systems and techniques provide promising solutions for tackling this challenge. In this article, we have introduced the basic principles for BackCom, summarized existing BackCom system and network architectures and discussed several emerging BackCom techniques. Moreover, we have described various applications of BackCom in IoT applications. With rapid advancements in both theory and applications, the technology is expected to play a key role in future IoT by enabling truly ubiquitous network connectivity, and pervasive sensing and computing.

REFERENCES

- [1] S. Sudevalayam and P. Kulkarni, "Energy harvesting sensor nodes: Survey and implications," *IEEE Commun. Surveys Tuts.*, vol. 13, no. 3, pp. 443–461, Third Quarter 2011.
- [2] K. Huang and X. Zhou, "Cutting the last wires for mobile communications by microwave power transfer," *IEEE Commun. Mag.*, vol. 53, no. 6, pp. 86–93, 2015.
- [3] C. Boyer and S. Roy, "Backscatter communication and RFID: Coding, energy, and MIMO analysis," *IEEE Trans. Commun.*, vol. 62, no. 3, pp. 770–785, Mar. 2014.
- [4] U. Karthaus and M. Fischer, "Fully integrated passive UHF RFID transponder IC with 16.7- μ W minimum RF input power," *IEEE J. Solid-State Circuits*, vol. 38, no. 10, pp. 1602–1608, 2003.
- [5] A. Bletsas, S. Siachalou, and J. N. Sahalos, "Anti-collision backscatter sensor networks," *IEEE Trans. Wireless Commun.*, vol. 8, no. 10, pp. 5018–5029, 2009.

- [6] J. Wang, H. Hassanieh, D. Katabi, and P. Indyk, "Efficient and reliable low-power backscatter networks," in *Proc. ACM SIGCOMM*, 2012, pp. 61–72.
- [7] W. Liu, K. Huang, X. Zhou, and S. Durrani, "Full-Duplex Backscatter Interference Networks Based on Time-Hopping Spread Spectrum," *IEEE Trans. Wireless Commun.*, vol. 16, no. 7, pp. 4361–4377, Jul. 2017.
- [8] V. Liu, A. Parks, V. Talla, S. Gollakota, D. Wetherall, and J. R. Smith, "Ambient backscatter: Wireless communication out of thin air," *ACM SIGCOMM Computer Communication Review*, vol. 43, no. 4, pp. 39–50, 2013.
- [9] V. Iyer, V. Talla, B. Kellogg, S. Gollakota, and J. Smith, "Inter-technology backscatter: Towards internet connectivity for implanted devices," in *Proc. ACM SIGCOMM*, 2016, pp. 356–369.
- [10] G. Yang, C. K. Ho, and Y. L. Guan, "Multi-antenna wireless energy transfer for backscatter communication systems," *IEEE J. Sel. Areas Commun.*, vol. 33, no. 12, pp. 2974–2987, 2015.
- [11] B. Clerckx and E. Bayguzina, "Waveform design for wireless power transfer," *IEEE Trans. Signal Process.*, vol. 64, no. 23, pp. 6313–6328, Dec. 2016.
- [12] M. Jain, J. I. Choi, T. Kim, D. Bharadia, S. Seth, K. Srinivasan, P. Levis, S. Katti, and P. Sinha, "Practical, real-time, full duplex wireless," in *Proc. ACM MobiCom*, 2011, pp. 301–312.
- [13] D. Dardari, R. D. Errico, C. Roblin, A. Sibille, and M. Z. Win, "Ultrawide bandwidth RFID: The next generation?" *Proc. IEEE*, vol. 98, no. 9, pp. 1570–1582, Sep. 2010.
- [14] T. Deyle, H. Nguyen, M. Reynolds, and C. Kemp, "RFID-guided robots for pervasive automation," *IEEE Pervasive Comput.*, vol. 9, no. 2, pp. 37–45, Apr. 2010.
- [15] Y. Zeng, R. Zhang, and T. J. Lim, "Wireless communications with unmanned aerial vehicles: Opportunities and challenges," *IEEE Commun. Mag.*, vol. 54, no. 5, pp. 36–42, May 2016.