

# Source Accountability with Domain-brokered Privacy

Taeho Lee, Christos Pappas, David Barrera, Pawel Szalachowski, Adrian Perrig

ETH Zurich

{kthlee, pappasch, david.barrera, psz, aperrig}@inf.ethz.ch

**Abstract**—In an ideal network, every packet would be attributable to its sender, while host identities and transmitted content would remain private. Designing such a network is challenging because source accountability and communication privacy are typically viewed as conflicting properties. In this paper, we propose an architecture that guarantees source accountability and privacy-preserving communication by enlisting ISPs as accountability agents and privacy brokers. While ISPs can link every packet in their network to their customers, customer identity remains unknown to the rest of the Internet. In our architecture, network communication is based on Ephemeral Identifiers (EphIDs)—cryptographic tokens that can be linked to a source only by the source’s ISP. We demonstrate that EphIDs can be generated and processed efficiently, and we analyze the practical considerations for deployment.

## I. INTRODUCTION

The commercialization of the Internet and its integral role in our daily lives have spawned a debate on privacy and accountability—a long-standing discussion about two properties that are typically considered conflicting. Unfortunately, today’s Internet does not provide native support for either. We propose an architecture that resolves the accountability-privacy tussle and guarantees network-level *source accountability* and end-to-end *communication privacy*.

On one end of the spectrum, source accountability protects the integrity of the source’s identity and holds the source responsible for any traffic that it originates. The lack of source accountability has become a Pandora’s box for Internet security. Attackers spoof their addresses and launch massive reflection attacks exhausting the available network resources. IP source address spoofing makes it impossible to identify the actual attacker and renders traffic filtering ineffective, not to mention the collateral damage when incorrectly blocking benign hosts.

On the other end of the spectrum is privacy. Recent revelations of pervasive monitoring and mass surveillance [15] have increased user awareness of communication privacy. Users know that their identities and network traffic are being systematically collected by state-level entities. The lack of native support for private communication in the Internet forces users to rely on overlay networks and specialized applications to obtain privacy guarantees [34]. These solutions are complex to install and manage, and degrade application performance.

To date, the research community has mainly investigated approaches that favor either privacy or accountability, typically offering one at the expense of the other. To our knowledge, the Accountable and Private Internet Protocol (APIP) is the main proposal that has aimed to find a balance between the two properties at the network layer [30]. However, the privacy guarantees are constrained to source anonymity; data privacy is not addressed but delegated to conventional protocols, such as IPsec [21] and its key exchange protocol (IKE [19]) that in themselves do not explicitly address a critical problem: certificate management (*e.g.*, issuance, revocation) at Internet-scale.

In this paper, we propose an Accountable and Private Network Architecture (APNA) that provides strong source accountability guarantees *and* privacy-preserving communication. Our notion of communication privacy covers host privacy (for the source and destination) and data privacy—host privacy means that the identity (*e.g.*, IP address) of the host remains private and data privacy means that the transmitted data remains secret from unintended recipients.

To provide such properties, we enlist Internet Service Providers (ISPs) as a fundamental component of our architecture for several reasons. First, we build on past efforts to hold Autonomous Systems (ASes) accountable for malicious traffic generated within their domain [24], [37]. Second, we believe ISPs have business incentives to provide privacy features to their customers, especially in light of recent revelations regarding global surveillance. While ISPs facilitate connection establishment between communicating peers, encryption of traffic is still performed directly by communication endpoints, keeping the content of the communication hidden even from the ISPs that provides Internet connection to the peers.

In our scheme, network communication is based on Ephemeral Identifiers (EphIDs) instead of long-lived network addresses, such as IP addresses. ASes issue EphIDs and assign them to their customer hosts as tokens of approval for communication. EphIDs are designed to mask the host address in the network, providing host privacy, while still providing a return address. Preserving the return address enables ICMP to function correctly in our scheme. In addition, EphIDs are bound to short-lived and domain-certified public/private key pairs. These keys are used by hosts to negotiate a shared secret key, which allows native payload secrecy through network-

layer traffic encryption.

The privacy architecture proposed in this paper, which establishes shared keys based on EphIDs, by default encrypts all payload data. Pervasive encryption frustrates large-scale traffic analysis by obfuscating all communicated content. Moreover, payloads are encrypted with Perfect Forward Secrecy (PFS) such that an adversary that obtains all long-term keys cannot decrypt the content of previous communication sessions.

EphIDs are cryptographically linked to the identity of a host and serve as accountability units. ISPs issue and assign EphIDs only to their authenticated customers, thus bootstrapping source accountability. We argue that ISPs are the natural accountability agents in today’s Internet since they already know the identities of their customers. Furthermore, we describe a shutoff protocol [4], which is a common security mechanism relying on source accountability. A complaining destination-host instructs an ISP to block outgoing traffic from a customer-host that is associated with an EphID. The accountable identifiers allow an ISP first to verify that a customer has sent traffic to a certain destination and then to terminate any further communication.

**Contributions.** This paper proposes a cohesive architecture, Accountable and Private Network Architecture (APNA), that simultaneously guarantees accountability and privacy by involving ASes as accountability agents and privacy brokers. In particular, APNA achieves the following properties:

- Source accountability by linking every packet in the network to its originating source.
- Host privacy by hiding the host’s identity from every entity except the host’s AS.
- Data privacy by supporting network-layer encryption with perfect forward secrecy.
- Support for feedback from the network back to the source (*e.g.*, ICMP).
- Support for a shutoff protocol that terminates unwanted communication sessions.

## II. PROBLEM DEFINITION

Our goal is to design a network architecture that simultaneously supports source accountability while preserving communication privacy. This section describes the necessary requirements to realize these seemingly conflicting goals, the security properties we strive to achieve, and the adversary models we consider. Throughout the paper we consider that the AS of the source host deploys APNA; and in Section VIII-E, we describe how an upstream ISP of the AS can provide APNA functionalities to the host.

### A. Source Accountability

Source accountability refers to an unforgeable link between the identity of a sender and the sent packet. Thus, accountability ensures that a source cannot deny having sent a packet and a host cannot be falsely accused of having sent a packet which it did not send.

Achieving source accountability in practice translates to two fundamental requirements. First, a strong notion of host

identity is necessary so that hosts cannot create multiple identities nor impersonate other hosts. Second, a link between the source’s identity and all of its traffic must be established. This link must be established (or at least confirmed) by a third-party (*e.g.*, source AS) that is not the sender itself, since senders can be malicious. To this end, the third party must observe all of the sender’s traffic such that every packet in the network can be linked to a specific sender.

**Adversary Model.** The goal of the adversary is to break source accountability by creating a packet that is attributed to someone else in the network. We assume that the adversary can reside in multiple ASes and that he can see all packets within those ASes. Specifically, the adversary can eavesdrop on all control and data messages in the network, but cannot compromise the secret keys of the AS.

### B. Communication Privacy

Our first goal with respect to privacy at the network layer is host privacy. To achieve host privacy, the identity of a host must be hidden from any other host in the source AS that is not in the same broadcast domain (*e.g.*, WiFi network, or LAN segment) as the host,<sup>1</sup> any transit network that forwards traffic, as well as the destination AS (including the communication peer). A host cannot hide from its AS, since the AS knows the identity and network attachment point of every customer. We address host privacy at the network layer, which means that network-layer headers should not leak identity information. A host’s identity may still leak at higher layers (*e.g.*, HTTP cookies); however, these aspects are out of scope for this paper.

In addition, our notion of host privacy includes sender-flow unlinkability [32]: simply by observing packet contents (both headers and payloads) of any number of flows originating from the same AS, the creator(s) of the flows are no more and no less related after the observation than they were before the observation.

Our second goal is data privacy through pervasive end-to-end encryption. Transmitted data should be hidden from unintended recipients, including the source and destination ASes. To this end, the architecture must natively (*i.e.*, without relying on upper-layer protocols) provide secure key establishment between hosts and protection against Man-in-the-Middle (MitM) attacks.

Moreover, our notion of data privacy includes perfect forward secrecy (PFS): disclosure of long-term secret keying material does not compromise the secrecy of exchanged keys from past sessions and thus data privacy of prior communication sessions is guaranteed [28, p. 496].

**Adversary Model:** Breaking *host privacy* means that an adversary can determine the identity of a sender, or can determine if two flows from the same source AS originate from the same host. We assume that the adversary can control any entity in the Internet except for the source host, hosts that are in the same broadcast domain as the source host, and

<sup>1</sup>Note that we exclude hosts in the same broadcast domain as the host since these hosts know the *Layer 2* address of the host.

the source AS. The adversary can observe packet headers and content, but we do not consider timing analysis techniques, such as inter-packet arrival times.

We argue that the architecture should provide only the basic building blocks to achieve host privacy at the network layer; and, for stronger privacy guarantees (*e.g.*, resiliency against timing analysis), protocols at a higher layer (*e.g.*, transport protocol) should provide such guarantees. For instance, a transport protocol could implement a packet scheduling algorithm that homogenizes timing between packets to prevent traffic identification algorithms based on inter-packet timing analysis [18]. Our argument is grounded by the fact that strong privacy guarantees often come at the expense of network performance, and not every user (or application) requires strong privacy guarantees. Hence, protocols that offer stronger privacy guarantees are left to upper layers so that users can choose the appropriate protocol based on their requirements.

An adversary can try to compromise *data privacy* by decrypting the content of a communication session between two hosts. To this end, we assume that the adversary can control any entity in the Internet except for the two communicating hosts and one of the two ASes that the hosts reside in.

### C. Additional Goals

**Shutoff Functionality.** An accountability architecture must provide security mechanisms that build on top of accountable addresses. A shutoff mechanism is commonly used to terminate any active communication session flagged for misbehavior. The architecture must ensure that the shutoff mechanism does not create other attack vectors, such as denial of service through non-permitted shutoff requests.

**ICMP Support.** The architecture should not sacrifice ICMP in favor of privacy due to its importance in the Internet. It is the Swiss army knife for network operators and is used for multiple purposes—from availability testing (*e.g.*, ping) to network debugging (*e.g.*, traceroute) and to performance optimizations (*e.g.*, MTU discovery).

## III. APNA OVERVIEW

This section describes the components of our Accountable and Private Network Architecture (APNA), beginning with the role of the ASes (Section III-A), followed by the use of ephemeral identifiers (Section III-B), and ending with an end-to-end communication example (Section III-C).

### A. Role of ASes

In APNA, ASes act both as accountability agents and as privacy brokers due to their position in the network. Since ASes already know the identity and the physical attachment point of their customers, they naturally act as *accountability agents*. At the same time, ASes mask their customers' identities from all other entities, and thus act as *host-privacy brokers*. In addition, ASes certify their customer-related information (*e.g.*, public keys), which is then used to generate keys for pervasive data encryption at the network layer; thus ASes act

as *data-privacy brokers*. We describe about each role in more detail in the following paragraphs.

**Accountability Functions.** As an accountability agent, the AS performs the following functions.

First, the AS creates a strong notion of host identity. To this end, the AS ensures that subscribers do not create and use multiple unauthorized identities for their communication. ASes already authenticate their customers and are thus selected as accountability agents.

Second, the AS creates a link between the identity of the source and the sent packet. To this end, the AS can store every packet or insert a cryptographic mark into every packet. Regardless of the implementation, the AS is on the forwarding path of all the traffic originating from its customers and is therefore selected to establish this link. Using any other third party as an accountability agent would require additional mechanisms to report every packet to the third party [30].

Third, the AS realizes the shutoff functionality by accepting (and validating) shutoff requests and blocking the corresponding flows. An AS is in a strategic position to block malicious traffic since it is close to the source and can stop traffic before it leaves its network.

**Privacy Functions.** As a privacy broker, the AS performs the following functions.

First, the AS masks the identity of its customer hosts by replacing the source address with an ephemeral identifier (EphID). This identifier serves as a privacy-preserving return address and thus does not break bidirectional communication. However, EphIDs must be bound to specific hosts and since ASes know the identities of the hosts, they are well suited to perform this binding and act as host-privacy brokers. We provide more details on EphIDs in Section III-B.

Second, the AS acts as a certificate issuer, certifying that a public key indeed belongs to a host in the AS's network. More specifically, the AS certifies the binding between an ephemeral identifier that is issued to a host and an ephemeral public key that is bound to the identifier. Hence, the AS becomes a data-privacy broker without revealing the identity of its customers.

### B. Ephemeral IDs

At the heart of our proposal is the use of ephemeral identifiers instead of addresses. An EphID is an identifier associated with the identity of a host, yet it does not leak identity information. Since ASes know the identities of their customers, issuing EphIDs to their connected hosts enables the hosts to hide their identity without sacrificing accountability.

**EphID as an Accountability Unit.** As an accountability unit, an EphID is an authorization token for communication that is issued by the AS to its customer hosts. Issuing these tokens requires strong host authentication: the host must first prove its identity to the AS and only then EphIDs can be issued.

In APNA, a host is represented to its AS through a Host Identifier (HID). An HID could be a hash of the host's public key or a number that is assigned by the AS to the host (*e.g.*,

IPv4 address). We do not specify how an AS assigns HIDs, but require that HIDs be unique within the AS’s boundary. There can be multiple EphIDs that are associated with an HID, and the EphIDs are cryptographically bound to the HID such that only the host AS can determine the binding. Furthermore, an EphID serves as the accountability unit for shutoff requests. A shutoff request against an EphID terminates all flows of the host that use that EphID as the source identifier. In other words, flows with the same source EphID are fate-sharing with respect to the shutoff protocol. Blacklisting source EphIDs instead of source and destination EphID pairs forces hosts to carefully manage their pool of assigned EphIDs.

**EphID as a Privacy Unit.** The EphID has two roles as a privacy unit: it hides the identity of a host and provides a tool to achieve sender-flow unlinkability. An EphID is meaningful only to the issuing AS and opaque to all other parties. It reveals no information about the host’s identity to other hosts inside the same AS nor to the peer host that the host is communicating with.

EphIDs alone are insufficient for routing packets to a destination, since location information is missing. Therefore, a host is fully addressed by an AID:EphID tuple. The AID identifies the AS in which the host resides (*e.g.*, Autonomous System Number) and the EphID is the ephemeral identifier issued to the host by the corresponding AS. Hence, the only leaked information is the AS where the host resides and the host’s anonymity set becomes the size of the AS in terms of number of hosts.

In addition, decoupling the identity from the address provides a means to achieve sender-flow unlinkability. A host can be issued multiple EphIDs and can use them at will, *e.g.*, a single EphID for all flows or a different EphID for every flow. We do not impose any requirements on how EphIDs are assigned. We discuss different granularities of EphIDs in Section VIII-A.

### C. Communication Example

We describe the high-level workflow for communication between two hosts (Figure 1). The protocol details are provided in Section IV.

The following logical entities are present in every AS:

- **Registry Service (RS):** authenticates and bootstraps hosts to the AS.
- **Management Service (MS):** issues EphIDs to the hosts.
- **Border Router (BR):** handles incoming and outgoing packets based on the AID:EphID tuple.
- **Accountability Agent (AA):** handles shutoff requests against the hosts in the AS.

In Figure 1, a host in  $AID_A$  is trying to communicate with a host in  $AID_B$ . Communication proceeds in four steps:

- 1) **Host Bootstrapping:** the host authenticates to its AS and receives bootstrapping information from its AS.
- 2) **EphID Issuance:** the host contacts the MS of its AS to obtain an EphID.
- 3) **Connection Establishment:** the hosts know each other’s AID:EphID identifiers and establish a shared key that

will be used for network-layer data encryption. The shared key is derived from public keys that are associated with the EphIDs. In Section VII-A, we describe how hosts can obtain the necessary communication information through DNS.

- 4) **Encrypted Communication:** the hosts proceed with the actual communication by using the corresponding AID:EphID tuples instead of network addresses and by encrypting every packet with their shared symmetric key.

## IV. APNA PROTOCOL DETAILS

We aim to construct a lightweight architecture that avoids keeping large amount of state on network nodes and uses symmetric cryptography for data transmission. More specifically, we make the following design choices in APNA:

- 1) symmetric encryption is used to cryptographically link EphIDs with HIDs; this allows an AS to efficiently obtain the HID from the EphID without a mapping table, which can be large;
- 2) proof of sending a packet is embedded in the packet, avoiding (excessive) storage overhead for ASes;
- 3) forwarding devices perform only symmetric cryptographic operations, guaranteeing high forwarding performance.

We begin by stating our assumptions, and proceed with the details of the steps that are shown in our example communication scenario in Section III-C (see Fig. 1). Table I summarizes the notation we use throughout the protocol description.

### A. Assumptions

- *We assume that the cryptographic primitives we use are secure.* For instance, we assume that the encryption scheme that protects data communication is CCA-secure. Hence, the adversary without an encryption key cannot learn anything about the protected plaintext from the corresponding ciphertext, and any modification to the ciphertext by the adversary is detected by the communicating hosts. For encrypting data communication, any conventional CCA-secure scheme [27], [36] can be used. Note that we also require that the generation of EphIDs to be CCA-secure, and in Section V-A1, we describe a CCA-secure encryption scheme for generating EphIDs.
- *Participating parties can retrieve and verify the public keys of ASes.* For example, a scheme such as RPKI [5] can be used to verify the public keys of the corresponding ASes. In addition, *for simplicity, ASes use the same public/private key pairs for 1) signing messages and 2) key exchanges.* In a real-world deployment, these two keys would be different, and the key used for signing messages would be registered with RPKI.
- *Hosts do not use connection sharing devices (e.g., NAT).* In other words, each host is directly visible to its AS. We relax this assumption in Section VII-B.

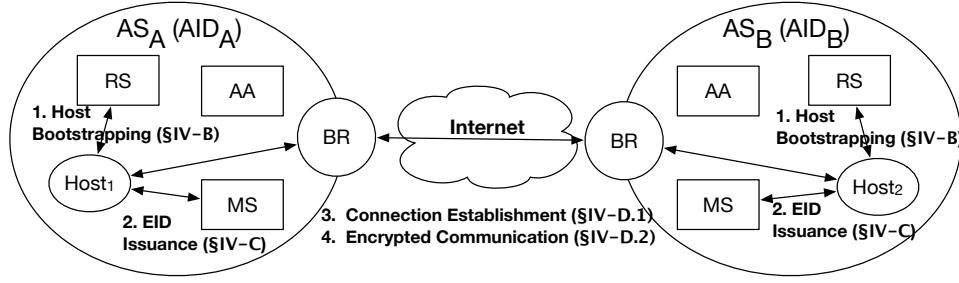

Fig. 1: An end-to-end communication example.

$k_{A_i}$	Symmetric key known among the infrastructure ( <i>e.g.</i> , routers, RS, MS, AA) within $AS_i$
$k_{H_i A_i}$	Symmetric key shared between host $H_i$ and its $AS_i$
$k_{E_i E_j}$	Symmetric key generated for the EphID pair $E_i$ and $E_j$
$HID_i$	Host identifier (HID) assigned to host $H_i$
$EphID_h$	An EphID issued to host $H$
$C_{H_i}, C_{E_i}$	Certificate for host $H_i$ and EphID $E_i$ respectively
$K_E^+, K_E^-$	Public, private key of entity $E$
$MAC_K(M)$	Message $M$ along with MAC of $M$ using symmetric key $K$
$\{M\}_{K^-}$	Message $M$ along with Signature of $M$ using private-key $K^-$
$E_k(M)$	Symmetric encryption of $M$ with key $k$
$E_k^{-1}(C)$	Symmetric decryption of $C$ with key $k$

TABLE I: Notation.

### B. Host Bootstrapping

Initially, a host authenticates to its AS and the bootstrapping procedure follows thereafter. Note that host authentication is the first step towards establishing source accountability and is an operation that every AS already performs. We do not specify how the host authenticates itself to the AS since well-established authentication protocols exist [13], [35]. For example, an AS can require a user to authenticate using login credentials that are created when the user subscribes to the AS. During the authentication process, we assume that the AS learns the public key of the host ( $K_H^+$ ).

Once the host has successfully authenticated, the Registry Service (RS) of the AS performs the bootstrapping procedure (Figure 2). During this procedure, the host receives information about its AS's services that are necessary to (later) establish communication sessions; and to support these communication sessions, the infrastructure of the AS gets updated with the host's information. We require that all bootstrapping messages are authenticated in order to avoid modifications en route.

First, the RS establishes two shared symmetric keys with the host. One key is used to encrypt EphID request and reply messages (Section IV-C), and the other key is used to authenticate every packet that the host creates and injects to the network. The two keys are computed by first performing a Diffie-Hellman (DH) exchange using the public/private key pairs of the host and his AS, and then deriving the two keys from the result of the DH exchange. Throughout the

discussion, for simplicity, we denote both keys as  $k_{HA}$ .

Next, the RS creates a control EphID ( $EphID_h^{ctrl}$ ) for the host. The host uses the control EphID to access the AS's services. For instance, using his  $EphID_h^{ctrl}$ , the host accesses the MS to request data-plane EphIDs. Both control and data-plane EphIDs are constructed identically (See IV-C), but they are used differently and have different expiration times. A control EphID is used for communication with the AS's internal services and has longer lifetime (*e.g.*, DHCP lease time) while a data-plane EphID is mainly used for data communication and is valid for the duration of a communication session. Using the same construction for both EphID types simplifies communication in APNA: all communication is based on EphIDs. For the paper, we use the term EphIDs to refer to the data-plane EphIDs.

The RS returns the following information to the host: the control EphID ( $EphID_h^{ctrl}$ ) with its expiration time ( $ExpTime$ ), and the certificates for the MS ( $EphID_{ms}$ ) and DNS ( $EphID_{dns}$ ) services. These certificates contain EphIDs, which are used as the destination identifiers to access the corresponding services, the expiration times for the EphIDs, and the public keys that are associated with the respective EphIDs.

Finally, the RS sends the host information ( $HID$ ,  $k_{HA}$ ) to infrastructure entities in the AS (*e.g.*, routers, MS, AA); the entities store the information in their database ( $host\_info$ ). The infrastructure of the AS must learn the host information in order to handle packets that are originating from and destined to this host. Specifically, the entities need to learn the  $HID$  of the host ( $HID$ ) and the shared key ( $k_{HA}$ ) with the host so that they can verify the authenticity of the packets that originate from the host.

### C. Ephemeral ID Issuance

An EphID is an encrypted token using the AS's secret key ( $k_A$ ); it contains the host's  $HID$  and an expiration time that indicates the validity period for the EphID (Equation 1). Note that the use of encryption enables the issuing AS to obtain the  $HID$  and expiration time from an EphID in a stateless fashion, without an additional mapping table; this allows an AS to handle an arbitrary number of EphIDs at a constant cost.

$$EphID = E_{k_A}(HID, ExpTime) \quad (1)$$

**AS Entities**: All infrastructures (e.g., border routers, MS) of the AS  
**g, p**: DH Parameters, **a**: A random DH Secret Integer  
**generateHID()**: Generate a unique HID  
**setExpTime()**: Create Expiration Time  
**verifySig( $K^+$ , M)**: Verifies signature of message  $M$  using  $K^+$

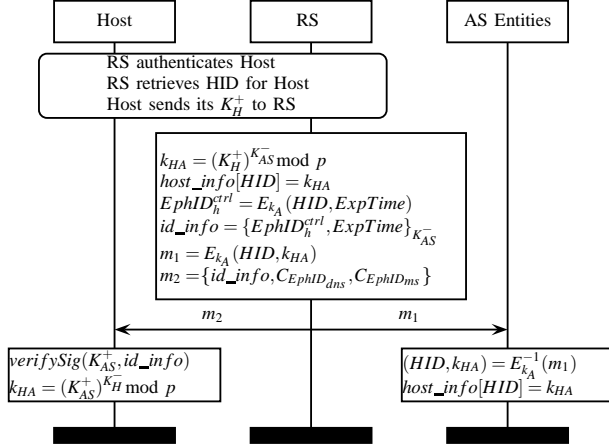

Fig. 2: Procedure for Host Bootstrapping.

Every EphID is associated with a public/private key pair ( $K_{EphID}^+$ ,  $K_{EphID}^-$ ), which serves two purposes: 1) to create a shared key with a peer host for data encryption (Section IV-D1), and 2) to authenticate shutoff requests (Section IV-E). Since the key pair is used by the host to create a data encryption key that is kept secret from the AS, it is generated by the host.

The AS certifies the binding between an EphID and a public/private key pair by issuing a short-lived certificate ( $C_{EphID}$ ) that has the same expiration time as the EphID. From the certificate, a peer host learns the public key ( $K_{EphID}^+$ ) that is associated to the EphID as well as the expiration time for the EphID. In addition to the information about the EphID, the certificate contains information about the issuing AS—the AID and the EphID of the accountability agent ( $EphID_{aa}$ ). The agent’s EphID is used by a peer host (with which the requesting host communicates) to initiate the shutoff protocol when necessary.

To obtain an EphID, the host creates and sends an EphID request message to the MS. Specifically, the host first generates the public/private key pair ( $K_{EphID}^+$ ,  $K_{EphID}^-$ ) for the EphID and includes  $K_{EphID}^+$  in the request message. In addition, the host uses  $EphID_h^{ctrl}$  as the source address for the request message and encrypts the message using the shared key with the AS ( $k_{HA}$ ). The message is encrypted to hide it from other entities in the AS that are not part of the AS infrastructure. If an adversary who tries to compromise sender-flow unlinkability (for the description of the adversary model, see Section II-B) can see the content of EphID request packets, he can identify a common sender across multiple flows at the level of  $EphID_h^{ctrl}$  as the initial packets to establish connections between two hosts contain  $K_{EphID}^+$  information for key negotiation purposes (Section IV-D1). That is, the adversary learns the ( $EphID_h^{ctrl}$ ,  $K_{EphID}^+$ ) pair from EphID request packets and searches for connection establishment packets that contain  $K_{EphID}^+$ s that maps to the same  $EphID_h^{ctrl}$ . Note that the adversary has

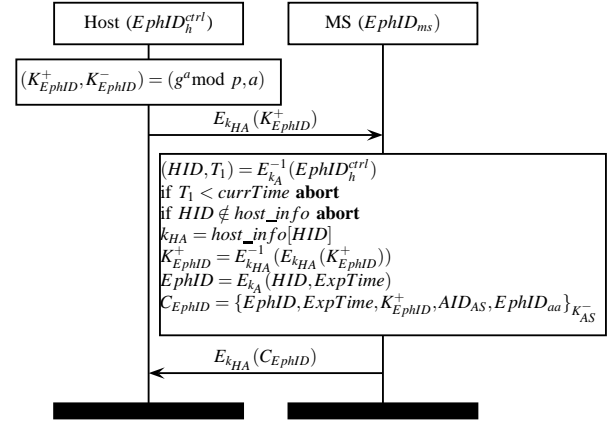

Fig. 3: Procedure for EphID Issuance.

not compromised the host identity since only the host’s AS can extract host identity from  $EphID_h^{ctrl}$ . Nonetheless, he has successfully identified a common sender across multiple flows. In APNA, encrypting the EphID request message prevents such attacks.

Upon receiving the request, the MS validates the authenticity of the request; decrypts the source EphID ( $EphID_h^{ctrl}$ ); and performs the following checks: 1)  $EphID_h^{ctrl}$  has not expired, 2) the client’s identifier ( $HID$ ) is valid (i.e., has not been revoked), and 3) the message is valid (i.e., the message can be decrypted successfully). If any one of the checks fails, the request is dropped.

Then, the MS proceeds with the EphID issuance: it generates an EphID and creates the short-lived certificate ( $C_{EphID}$ ) for the EphID. Finally, the MS encrypts the certificate and sends it to the requesting host. The certificate is encrypted so that an adversary cannot relate different EphIDs to the control EphID of the requesting host by observing the content of the EphID reply packets.

#### D. Data Communication

To communicate, two hosts first generate a shared symmetric key for their communication session. This key is then used to encrypt all traffic that belongs to this communication session. We emphasize that two hosts can create multiple communication sessions and each session has a different symmetric key to ensure that disclosure of one encryption key does not compromise data privacy of other communication sessions. We provide further details.

1) *Connection Establishment*: For every connection establishment between a pair of hosts, the two hosts perform the following tasks: 1) verify each other’s EphID certificate that is issued by their corresponding ASes, and 2) establish a shared key via a DH key exchange to encrypt their communication.

Consider two hosts,  $A$  and  $B$ , with EphIDs  $EphID_a$  and  $EphID_b$ , respectively, that are trying to establish a connection with each other. Assume that the hosts have obtained each other’s EphID and the associated certificate (we discuss obtaining EphIDs through DNS in Section VII-A). Using the short-lived certificate of  $EphID_b$  and the public-private key pair associated with  $EphID_a$ ,  $A$  derives a shared key ( $k_{E_aE_b}$ )

between  $EphID_a$  and  $EphID_b$ . Similarly,  $B$  computes the same shared key, completing the connection establishment. This symmetric shared key is then used to encrypt data packets between the two hosts.

2) *Encrypted Communication*: After the connection establishment, communication is based on symmetric cryptographic operations. First, the host uses the symmetric key that it shares with the peer to encrypt the packets to the peer. Any existing CCA-secure encryption scheme can be used. Second, the host computes a MAC for every packet that it sends, using the symmetric key that is shared with its AS ( $k_{HA}$ ). This allows the host's AS to link every packet to its source and to drop packets from (potentially) malicious hosts.

3) *Data Forwarding*: Forwarding operations at border routers in source ASes ensure that only packets from authenticated hosts and authorized EphIDs leave the source AS. Border routers in destination ASes forward packets to the correct hosts based on the destination EphIDs. Transit ASes do not perform additional operations and simply forward packets to the next AS on the path. As per our design choice, only symmetric cryptographic operations are used, enabling a high-performance data forwarding.

Recall that communication end-points are specified as AID:EphID tuples. For inter-domain forwarding, border routers use AID to forward packets. Specifically, for external packets entering the AS, an border router checks whether the packet has arrived at the destination AS. If not, the packet is forwarded to the neighboring AS towards the destination AS. At the destination AS, the border router checks the following conditions: 1) the destination EphID ( $EphID_d$ ) has not expired, 2)  $EphID_d$  has not been revoked, and 3)  $HID_D$  is valid (*i.e.*, is registered and non-revoked).

If all conditions are satisfied, then the packet is forwarded to the destination host: border routers derive the corresponding HID from the EphID and then forward the packet; we assume that intra-domain routers forward packets based on HIDs (*e.g.*, IP addresses).

For outgoing packets, an border router forwards the packets to a neighboring AS only if all of the following conditions are satisfied: 1) the source EphID ( $EphID_s$ ) has not expired, 2)  $EphID_s$  has not been revoked, 3)  $HID_S$  is valid, and 4) the MAC in the packet is correct.

To verify the MAC in the packet, an border router retrieves the shared key ( $k_{HA}$ ) between the source host and the AS by searching the host information database ( $host\_info$ ) using the  $HID$  of the source host as the key. These checks ensure that only authenticated packets leave the source AS.

### E. Shutoff Protocol

Shutoff protocols are designed to allow hosts to selectively block traffic from specific source hosts. In our architecture, an accountability agent checks the validity of a shutoff request and then blocks the source EphID. The agent checks whether a customer-host has actually sent the specific packet that the requesting party reports and whether the party is authorized to make the request (*i.e.*, the requesting host was indeed the

**AID**: AID of the Destination AS  
**EphID<sub>s</sub>, AID<sub>s</sub>**: Source EphID and AID in the packet  
**EphID<sub>d</sub>, AID<sub>d</sub>**: Destination EphID and AID in the packet  
**revoked\_ids**: List of revoked EphIDs  
**verifyMAC(k,M)**: Verifies MAC of message  $M$  using  $k$

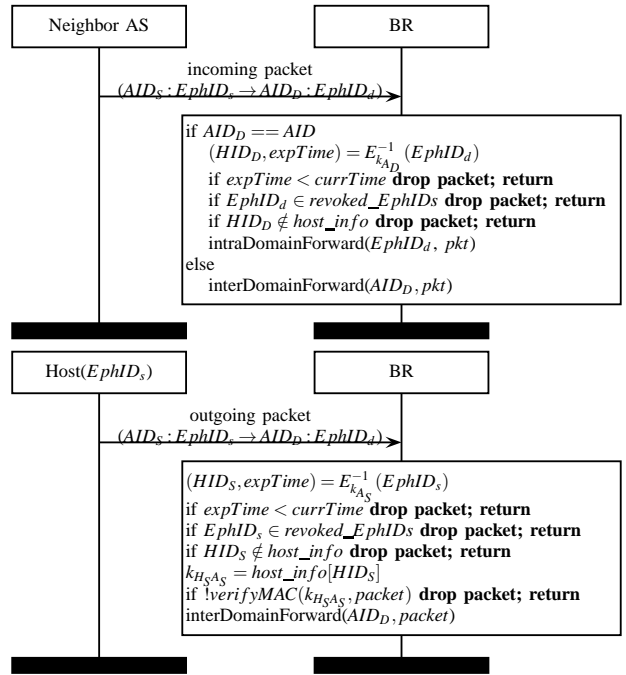

Fig. 4: Procedures for Data Packet Forwarding at Border Routers for Incoming (Top) and Outgoing (Bottom) Packets.

recipient of the specific packet). The agent does not examine the intent of the source and whether the packet is malicious.

Figure 5 shows the procedure for the shutoff request: the destination host that owns  $EphID_d$  is attempting to block traffic coming from  $EphID_s$  after receiving a specific packet. The destination host creates a shutoff request message with the following information: 1) the received packet, 2) a signature over the unwanted packet using the private key of  $EphID_d$  ( $K_{EphID_d}^-$ ), and 3) the certificate of  $EphID_d$ . The packet is included as evidence that the source has indeed sent traffic to the destination and the shutoff request is not rogue; the signature and the certificate prove that the destination host owns  $EphID_d$ . Then, the destination host sends the request message to the accountability agent of the source host.

Upon receiving the request, the accountability agent verifies the certificate of  $EphID_d$  and the signature in the request message to confirm that the request has indeed been made by the destination host who owns  $EphID_d$ . Then, to ensure that the packet has been actually generated by the source that owns  $EphID_s$ , the agent checks the authenticity of the packet using the shared key ( $k_{H_sAS}$ ) with the source host. Finally, the accountability agent instructs the border routers to revoke  $EphID_s$  by putting it into their  $revoked\_ids$  list.

If misused, the shutoff protocol can be used to launch a DoS attack against a benign source. To reduce the risk of such DoS attacks, we only authorize the recipient of a packet to initiate a shutoff request (*i.e.*, the destination AS and the destination

$EphID_s, EphID_d$ : Src/Dst EphIDs in the packet  
**Dst**: Dst Host (*i.e.*, Host that is using  $EphID_d$ )  
**pkt**: packet that is sent by the Src Host but unwanted by the Dst Host  
**AA<sub>s</sub>, BR<sub>s</sub>**: Accountability agent, Border Router at Source AS

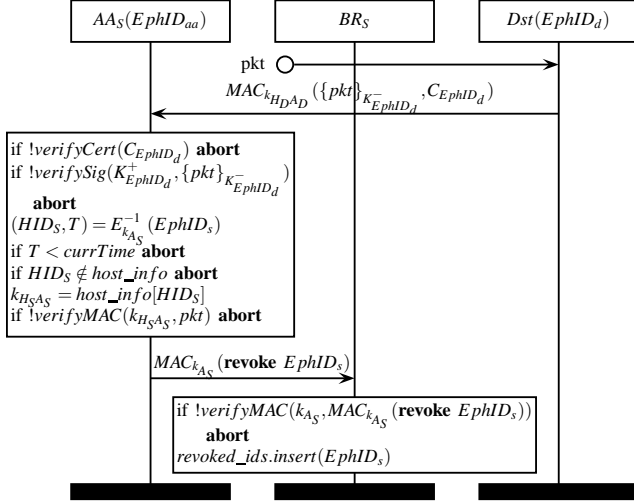

Fig. 5: Procedure for Shutoff Protocol.

host that owns the destination EphID). In Section VIII-C, we discuss how other entities on the communication path can be authorized to initiate a shutoff request.

## V. IMPLEMENTATION & PERFORMANCE EVALUATION

We present the implementation and performance evaluation of the core architecture’s components—the EphID management server and an border router.

### A. EphID Management Server

The EphID Management Server (MS) is responsible for generating EphIDs and for assigning them to hosts. The EphID generation must be efficient since our architecture should support even per-flow EphIDs. We describe the EphID structure, the MS implementation, and then evaluate the performance of the EphID generation procedure.

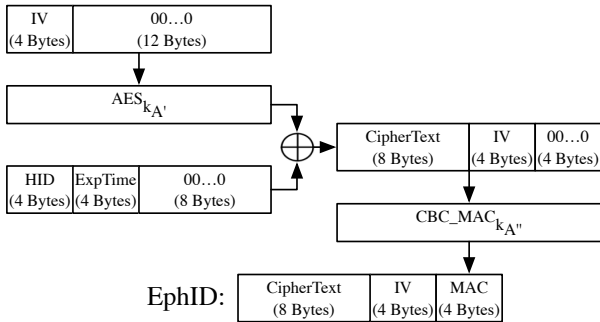

Fig. 6: EphID Construction.

1) *EphID Structure*: We engineer the EphID length to optimize for AES processing; AES operates on 16-byte (B) blocks and is the only cipher with widespread hardware support.

An EphID requires the HID of the host and an expiration time ( $ExpTime$ ). We use 4 B for the HID, which are sufficient to uniquely represent all hosts even in large ASes. The expiration time is 4 B long, which allows us to use Unix timestamps with one second granularity.

Recall that the security requirement for EphIDs is a CCA-secure encryption scheme. To this end, we use a generic composition called Encrypt-then-MAC [7] that combines a symmetric encryption with a message authentication code (MAC) (Figure 6). First, the concatenation of  $HID$  and  $ExpTime$  is encrypted using AES in counter mode. Secure operation of this mode requires a unique initialization vector (IV) for every encryption (*i.e.*, for every EphID). Moreover, the use of the IV allows us to generate multiple EphIDs for a single  $HID$ . Note that the plaintext data is shorter than a single AES block (16 B) and thus the input must be padded to 16 B; the one-block plaintext requires a single AES operation.

Next, a message authentication tag is computed. The tag is computed over the first 8 B of the previously generated ciphertext and the IV that was used in that encryption. We use CBC-MAC based on AES to generate the authentication tag.

Finally, the EphID is constructed from the 8 B of the ciphertext, 4 B of the IV, and 4 B of the authentication tag (computed over the first two values); the total length is 16 B. Note that the keys used for encryption ( $k_{A'}$ ) and authentication ( $k_{A''}$ ) are different; however, they can be derived from the secret key of the AS ( $k_A$ ).

2) *MS Implementation*: The MS generates EphIDs according to the procedure in Figure 3. For asymmetric cryptography, we use cryptographic primitives based on Curve25519 [9], which is proven to have high performance and features small public-keys (32 B) and small signatures (64 B). Key exchange is done using the elliptic-curve variant of Diffie-Hellman (ECDH). To create digital signatures for certificates, we use the ed25519 signature scheme [10] and the ed25519 SUPER-COP REF10 implementation<sup>2</sup>. For symmetric cryptographic operations, we leverage Intel AES-NI [16] – a new encryption instruction set. Furthermore, we implement the host database ( $host\_info$ ) that stores the shared keys between hosts and the AS as a hashtable using HID as the key.

As an optimization, we parallelize the EphID generation by using 4 processes to simultaneously handle EphID requests. The parallelization is straightforward since the generation does not require any coordination (*e.g.*, shared memory or inter-process communication) between the processes. However, no other optimizations were performed (*e.g.*, optimizing the ed25519 REF10 implementation).

3) *MS Performance Evaluation*: We demonstrate the efficiency of generating per-flow EphIDs. To this end, we need statistics for the peak flow generation rate inside an AS.

We use a 24-hour packet trace of HTTP(S) traffic from a major network provider that manages network connections to universities and research facilities in an European country.

<sup>2</sup><http://bench.cr.yp.to/supercop.html>



Source AID	4 Bytes	<table border="1"> <thead> <tr> <th>Field</th> <th>Length</th> </tr> </thead> <tbody> <tr> <td>HID</td> <td>4 Bytes</td> </tr> <tr> <td>ExpTime</td> <td>4 Bytes</td> </tr> <tr> <td>IV</td> <td>4 Bytes</td> </tr> <tr> <td>MAC</td> <td>4 Bytes</td> </tr> <tr> <td>Total</td> <td>16 Bytes</td> </tr> </tbody> </table>	Field	Length	HID	4 Bytes	ExpTime	4 Bytes	IV	4 Bytes	MAC	4 Bytes	Total	16 Bytes
Field	Length													
HID	4 Bytes													
ExpTime	4 Bytes													
IV	4 Bytes													
MAC	4 Bytes													
Total	16 Bytes													
Source EphID	16 Bytes													
Dest AID	4 Bytes													
Dest EphID	16 Bytes													
MAC	8 Bytes													
Total	48 Bytes													

Fig. 7: APNA Header Information and EphID Field Lengths.

The trace contains over 104 million and 74 million entries for HTTP(S) traffic respectively. Each entry contains a timestamp and anonymized source/destination IDs. We identify 1,266,598 unique hosts generating a peak rate of 3,888 active HTTP(S) sessions per second.

We test our implementation on a desktop machine with an Intel Core i5-3470s CPU (4 cores, 2.9GHz) and 4 GB of DDR3 memory. For 500,000 EphID requests, our implementation runs for 6.9 seconds. On average,  $13.7\mu\text{s}$  are needed for a single EphID generation, translating to a generation rate of 72.8k EphIDs/sec — over 18 times higher than the request rate. Our experiment shows that even a low-end desktop machine can keep up with the traffic demands of a real AS that has over 1.2 million hosts.

### B. Border Router

We describe our border router prototype starting with the structure of the network header. Then, we describe the border router implementation and evaluate the forwarding performance.

1) *APNA Header Information*: The network header information (Figure 7) contains the source and destination end points (expressed as AID:EphID tuples) and a MAC over the packet’s content. We use 4 B to express the AID since 4 B are used for AS numbers in the Internet; the EphID field requires 16 B as described in Section V-A1; the MAC field requires 8 B. The fields in the packet header sum up to 48 B.

2) *Border Router Implementation*: Our border router performs additional processing compared to traditional IPv4/IPv6 forwarding (Figure 4). Namely, the border router additionally performs one decryption, two table lookups, and one MAC verification.

We use DPDK [1] as our packet processing platform, which allows us to implement the required functionality in userspace. The decryption of the EphID in the packet is implemented through Intel AES-NI [16].

3) *Forwarding Performance Evaluation*: We evaluate the forwarding performance on a commodity server with two Intel Xeon E5-2680 CPUs and two non-uniform memory access (NUMA) nodes; each NUMA node has four banks of 8 GB DDR3 RAM. The server is equipped with 6 dual-port 10 GbE NICs, providing a total capacity of 120 Gbps. To generate traffic, we use Spirent-SPT-N4U-220 [2] connected back-to-back with the server. The server receives the traffic, processes it, and sends it back to the generator.

We perform a throughput experiment for 5 different packet sizes — 128, 256, 512, 1024, and 1518-byte packets. The results (Figure 8) confirm that we are able to perform the

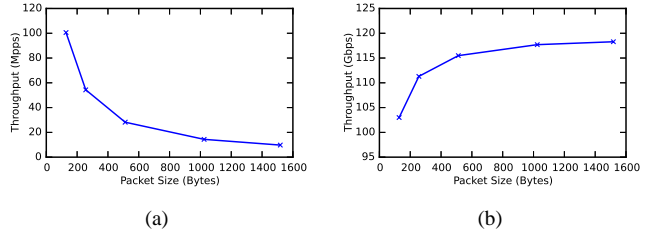

Fig. 8: Forwarding performance expressed as (a) packet-rate and (b) bit-rate.

required additional processing without incurring a throughput penalty. The measured performance matches the theoretical maximum performance; we omit this performance line for demonstration purposes since the two lines match. Figure 8(a) shows that even for small packet sizes (*i.e.*, high packet-rates), the border router performs optimally. Figure 8(b) shows that as packet sizes increase, we saturate the capacity of 120 Gbps. The border router performs optimally because the additional operations are lightweight. The border router’s CPUs have adequate capacity to perform this processing without degrading performance for the given packet rates. Under higher packet rates, the heavier load would start to degrade forwarding performance slightly.

## VI. SECURITY ANALYSIS

We demonstrate how APNA prevents attacks that undermine source accountability and data privacy.

### A. Attacking Source Accountability

An adversary attacking source accountability (Section II-A) has three attack vectors at hand.

**EphID Spoofing.** The adversary can attempt to use an EphID that is issued to another host (the spoofed victim). For instance, an adversary that shares the same access port with the victim can sniff traffic and observe valid EphIDs that are in use. However, using such an EphID is not sufficient since every outgoing packet has to contain a MAC that is computed with the shared key between the host and the host’s AS. Without the corresponding shared key, the adversary cannot create valid MACs, resulting in spoofed packets that are dropped by the host’s AS (additionally making the attack visible). Obtaining the shared key requires compromising the host: the shared key is generated with a DH key exchange between the host and the Registry Server (Figure 2), which means that the adversary needs the DH private value that is used for the EphID generation; our adversary model does not account for a compromised host.

An active adversary can attempt to obtain an EphID by pretending to be another host. However, such an attack is infeasible: the adversary not only needs to learn the control EphID ( $EphID_h^{ctrl}$ ) of the victim, but also needs to learn the shared key between the victim and the source AS.

**Unauthorized EphID Generation.** The adversary can attempt to create an unauthorized EphID. However, such an

attempt is not feasible since the EphID construction (Figure 6) is CCA-secure.

We achieve a CCA-secure encryption scheme through two primitives. First, we use symmetric encryption in counter mode with a fresh IV for every encryption; this encryption is secure under a chosen plaintext attack. Second, we use a CBC-MAC scheme to authenticate the concatenation of the ciphertext and the IV. Note that our use of the CBC-MAC is secure against chosen plaintext attacks since the input length to the CBC-MAC is fixed to 16B.<sup>3</sup> The combination of these two primitives results in CCA-secure encryption scheme [7].

**Identity Minting.** A common attack against systems that provide accountability is identity minting, whereby a malicious host attempts to create multiple (unauthorized) identities. In APNA, since host identifiers (HIDs) are generated by the AS and assigned only to the hosts that have authenticated, the hosts cannot independently create multiple identifiers. In addition, if a host requests a new HID, the previous HID and all associated EphIDs are revoked by the AS. Thus, at any moment every host on the network is identified by a single HID.

### B. Attacking Privacy

An adversary attacking data privacy can attempt to eavesdrop on communication data or store it and decrypt it once he obtains the encryption keys. In APNA, traffic is encrypted by default and our scheme achieves perfect forward secrecy: The symmetric key that is used for data encryption is bound to the EphID (and the public/private key pair for that EphID) that is used for the corresponding communication session. This key pair is not used to derive other encryption keys and is not derived from other long-term private keys ( $K_{AS}^-, K_H^-$ ). Hence, only the compromise of a private key for an EphID compromises data privacy and only for the communication session that uses this EphID.

Alternatively, an AS-level adversary can actively try to compromise data privacy of a customer host through a MitM attack. The malicious AS can perform a MitM attack during the shared key establishment between the victim ( $EphID_v$ ) and a peer host ( $EphID_p$ ). In this attack the malicious AS replaces the certificate for the EphID of the victim host ( $C_{EphID_v}$ ) with another (fake) certificate, pretending to be the victim host to the peer host; the peer host accepts  $C_{EphID_v}$ . However, the AS cannot deceive the victim by pretending to be the peer host because it cannot generate the certificate for  $EphID_p$  ( $C_{EphID_p}$ ) that is signed by the private key of the peer host's AS. Consequently, the connection is not established and the adversary cannot read any communication of the hosts. The MitM attack is only possible if the source and destination ASes collude, which we do not consider in our model.

For communication between two hosts in the same AS (*i.e.*, intra-domain communication), APNA does not provide any privacy guarantee from the AS: the identities of the two hosts are already known to the AS (compromising host privacy), and

the AS can perform MitM attacks to decrypt communication between the hosts (compromising data privacy) as the AS can fake both certificates for the EphIDs that the hosts use. The two hosts can use security protocols in higher layers (*e.g.*, TLS) to encrypt the content of the communication.

### C. Other Attacks

**Unauthorized Shutoff Requests.** The shutoff protocol can be misused to perform a denial-of-service attack against a host. To prevent such an attack, three measures are implemented to prevent unauthorized shutoff requests. First, only the destination host and destination AS are authorized to issue a shutoff request. Furthermore, the shut-off requester has to present the unwanted packet that proves that the source has indeed sent the packet. Since every packet has been cryptographically marked by the source AS, the destination cannot make a shutoff request with a rogue packet. Lastly, the shutoff requester must present its authorization credentials—it needs to sign the request message with the private key associated with the destination EphID, and include the corresponding short-lived certificate in the request message, proving that it is an authorized party.

**DDoS Attacks on Hosts.** The architecture provides intrinsic defense against DDoS attacks for three reasons. 1) Since spoofing the source identifier is difficult, reflection DDoS attacks (*e.g.*, DNS reflection) are difficult to launch. 2) The shutoff protocol allows the victim to suppress unwanted traffic. 3) Due to strong accountability, the victim can ask the AS of malicious host to take action against the host behind the EphIDs that are generating a lot of DDoS attack traffic.

## VII. PRACTICAL CONSIDERATIONS

### A. DNS Registration

Today, the names of publicly accessible services (*e.g.*, an online shopping website) are typically registered to public DNS servers. In APNA, the servers that host such services publish the EphID to a public DNS server, and the DNS server returns the EphID with the corresponding certificate for a requested domain name. To this end, the server performs two tasks: 1) it requests an EphID and the associated certificate from its AS; and 2) it registers the certificate under the domain name to DNS;<sup>4</sup> the registered EphID will be used as the destination address in future communication.

Publishing certificates to the DNS raises a problem: a shutoff request against a published EphID would terminate any ongoing communication sessions that use this EphID. A naïve solution is to update the DNS entry with a new EphID whenever the published EphID becomes invalid. However, this would become burdensome for the DNS infrastructure if attackers continuously issue shutoff requests against a domain.

Our solution is to define *receive-only EphIDs*—EphIDs that are used only to receive packets and are never used as the source EphIDs. Since they are never used as the source identifier, they cannot become the target of shutoff requests. To

<sup>3</sup>CBC-MAC is insecure for variable-length messages [6].

<sup>4</sup>We assume DNSSEC to authenticate DNS records.

avoid using receive-only EphIDs as the source identifier, the communication establishment to a server needs to be changed (*i.e.*, the server does not respond to the client using the receive-only EphID).

**Client-Server Connection Establishment.** To support receive-only EphIDs by the server, the connection establishment procedure in Section IV-D1 is extended. To simplify the narrative, assume that the client uses  $EphID_c$  to connect to the server, and that the server uses  $EphID_r$  as the receive-only EphID and  $EphID_s$  to serve the client.

After obtaining  $EphID_r$  from DNS, the client contacts the server using  $EphID_c$  and  $EphID_r$  as the source and destination EphIDs, respectively. The server verifies the short-lived certificate of  $EphID_c$  and computes a shared key that will be used to encrypt data packets between the client and the server. However, instead of using the short-lived certificate of  $EphID_r$ , the server uses the short-lived certificate of  $EphID_s$  to compute the shared key. Then in the response message to the client, the server includes the short-lived certificate of  $EphID_s$  to inform the client that  $EphID_s$  will be used by the server to serve the client.

The client verifies the short-lived certificate of  $EphID_s$  and computes the shared key using the certificates for  $EphID_s$  and  $EphID_c$ . In addition, the client uses  $EphID_s$  as the destination EphID to communicate to the server.

**Protecting DNS Queries.** Using the certificates for the two EphIDs (*i.e.*,  $EphID_c$  and  $EphID_r$ ), DNS queries are encrypted just like any other data communication. Hence, only the DNS server and the host knows the content of the query (*e.g.*, domain name). However, if the DNS server is operated by the host's AS, the AS can compromise the privacy of the DNS query—the AS knows the identity of the host from the EphID and retrieves the content of the query from the DNS server. To prevent such a compromise, the host can use a DNS server that he trusts and that is not operated by the AS that he resides in.

**DNS Poisoning.** A malicious AS can poison its local DNS servers with rogue entries. When the victim attempts to connect to a certain domain, the AS can successfully launch a MitM attack. We do not explicitly address DNS security since it is not a network-layer issue. With APNA, users can securely communicate with a trusted DNS server of their choice, avoiding their AS.

## B. Hosts Behind Connection-Sharing Devices

In the Internet, connection sharing devices (*e.g.*, NAT) are often used. For example, DSL or cable modems often have wireless Access Point functionality that allows multiple devices (*e.g.*, laptops, smart phones) to connect to the Internet; and, Internet cafés share their Internet connection and make it accessible to their customers. In this section, we describe two approaches that embrace connection-sharing devices in APNA. For brevity, a connection sharing devices is referred to as an Access Point (AP).

**Bridge-mode.** In this approach, the AP serves as a transparent bridge that interconnects users behind the AP to the AS. The AS requires all users to be directly authenticated to itself. In this approach, the AS needs to authenticate every single user, even those that may stay in the AS network for only a short period of time. Alternatively, the AS can delegate the management of connection sharing to the corresponding APs.

**NAT-mode.** In this approach, the AP creates a small domain of its own while acting as a host to the AS network. That is, the AP performs the protocol described in Section IV as a host to the AS while playing the roles of a RS, an MS, a router, and an accountability agent on behalf of its clients.

As a RS, the AP bootstraps the hosts into the AP's internal network: it authenticates the hosts to the internal network, negotiates shared keys that are used to authenticate the packets that the hosts send, and provides bootstrapping information.

As an MS, the AP makes EphID requests on behalf of its hosts to the AS. The procedure that the AP follows to acquire EphIDs for its hosts is similar to the EphID issuance protocol described in Figure 3, but with two differences. First, when requesting for an EphID to the MS of the AS, the AP uses an ephemeral public key that is supplied by its host. Second, the AP keeps track of the EphIDs that are assigned to the hosts as a list, *i.e.*,  $EphID\_info$  (as opposed to deriving HIDs from EphIDs) since EphIDs are encrypted using the AS's secret key and EphIDs contain HIDs assigned to the AP, not to its hosts. This list is used to identify the hosts using EphIDs in the packets.

As a router, the AP implements the data forwarding procedures described in Figure 4, but with two differences. First, instead of parsing the EphIDs to determine the HID of the host, the AP uses the  $EphID\_info$  list. Second, for outgoing packets, in addition to verifying the MAC in the packets using the shared keys with its hosts, the AP replaces the MAC using its shared key with the AS before forwarding the packets to the AS.

Finally, as an accountability agent, the AP identifies the misbehaving hosts based on EphIDs. Since the hosts behind an AP are not visible to the AS and since the AS issues EphIDs to the AP not to the hosts, the AS holds the AP accountable for misbehaving EphIDs. Then, the AP determines the host that is using the misbehaving EphID.

## C. Connection Establishment Latency

In Section IV-D1, we described how two hosts establish a connection with each other: using the short-lived certificates for the two EphIDs, the two hosts compute the symmetric shared key that is used for data encryption. The connection establishment requires one Round Trip Time (RTT) before any communication can take place; however, this RTT can be eliminated. On the very first packet of the connection establishment, the host encrypts its data after computing the shared key. Then, the receiving host decrypts the data after computing the shared key.

In the case of client-server communication, the connection establishment (described in Section VII-A) requires 1.5 RTTs,

but this latency can be reduced to 0 or 0.5 RTT depending on the desired level of data privacy. If the client encrypts data on the first packet using the shared key between her EphID and the receive-only EphID of the server, the client incurs zero RTT in connection establishment. However, if an adversary compromises the private key of the receive-only EphID, the adversary can decrypt the first packets of all communication sessions with the server. The compromise of the first packets is eliminated if a client does not send data on the first packet; however, this incurs latency penalty of 0.5 RTT.

#### D. Deployment in the Internet

Although our ideas are not restricted to a certain Internet architecture, APNA can be used in today’s Internet. To this end, the Generic Routing Encapsulation (GRE) protocol [14], which uses the IPv4 network as virtual Point-To-Point (PTP) links to encapsulate various network protocols (*e.g.*, tunneling IPv6 sites over IPv4 network) can be used. In APNA, GRE encapsulation can interconnect two APNA entities, *e.g.*, between two APNA routers over IPv4 network.

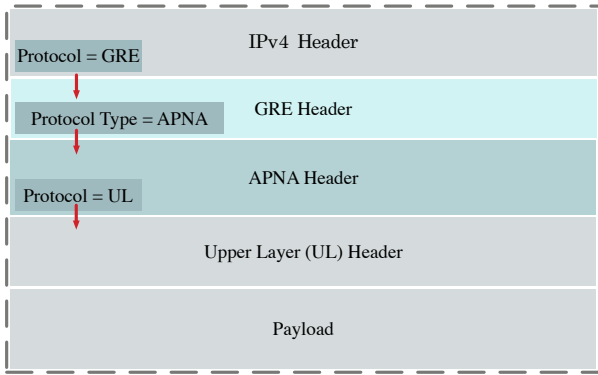

Fig. 9: APNA Packet Structure.

Figure 9 shows the APNA packet structure using the GRE protocols. The source and destination addresses of the IPv4 header are that of the two APNA entities that are sending and receiving the APNA packet. The APNA header and the data payload follow the GRE tunnel header; the GRE tunnel specifies the encapsulated network protocol using the *Protocol Type* field. Since the GRE protocol uses the *EtherType* numbers for identifying the encapsulated protocol, we would need to request a dedicated *EtherType* number from IANA.

IPv4 addresses of the hosts serve as the HIDs in the IPv4 deployment. Note that IPv4 addresses and HIDs are both four bytes long, and IPv4 addresses are uniquely assigned to hosts in an AS. In addition, IPv4 addresses of APNA routers serve as AIDs so that inter-domain routing continues to be based on IPv4 addresses.

For intra-domain forwarding in the source AS, the source host puts its IP address and the IP address of an APNA router as the source and destination addresses in the IPv4 header (that comes before the GRE header), respectively. For intra-domain forwarding in the destination AS, an APNA router 1) decrypts the destination EphID in the APNA header to get the HID

(*i.e.*, IPv4 address) of the destination host; and, 2) replaces the destination IPv4 address of the IPv4 header with the HID.

This intra-domain forwarding has a privacy implication. Within the source and destination ASes, the addresses of the hosts are visible; hence, it is not possible to provide any privacy guarantee against an adversary who observes packets within the ASes. However, once an AS fully deploys APNA (*i.e.*, all routers forward packets based on EphIDs), this privacy implication disappears.

For inter-domain forwarding in the source AS, a APNA router replaces the addresses in the IPv4 header of the APNA packet with its IPv4 address and the destination AID as the new source and destination addresses, respectively. For all transit ASes, the packet is forwarded based on the destination address in the IPv4 header.

**APNA Gateway.** Making modifications to the host network stack is an onerous task that hampers deployment of novel architectures. Hence, we propose using APNA gateways to bridge between the Internet and APNA without having to change the host network stack. An APNA gateway has two roles: 1) as an APNA host, it runs the protocols described in Section IV; and 2) as a packet translator, it converts between native IPv4 and APNA packets. Assuming that the gateway uses different source EphID for different IPv4 flows, the challenge in translating between IPv4 and APNA packets is determining the mapping between IPv4 flow information (identified by the standard 5-tuple) in IPv4 packets and APNA flow information (identified by source and destination AID:EphID pair) in APNA packets.

When forwarding an outgoing IPv4 packet from a host to an APNA router, the gateway converts the IPv4 packet to a APNA packet. IPv4 addresses in the APNA packet can be easily determined: the addresses of the gateway and the APNA router are used as the source and destination IP addresses, respectively. In addition, the source AID:EphID information in the APNA header can be easily determined: for each new IPv4 flow, the gateway uses a different EphID. However, determining the destination AID:EphID is not trivial. In fact, the gateway cannot determine the destination AID:EphID solely based on the 5-tuple information in the IPv4 packet from the host.

Instead, the gateway has to rely on mechanisms that the host uses to find its peer host. For instance, a client may use DNS that stores the short-lived certificate and the IPv4 address of the server. The gateway that serves the client learns the IPv4 address and the AID:EphID of the server by inspecting the DNS reply to the client. Then, the gateway uses the destination IPv4 address in the IPv4 packets from the client to the server to get AID:EphID of the server.

Note that the gateway can automatically learn the IPv4 address to AID:EphID mapping only if the host uses a well-known mechanisms (*e.g.*, DNS). Otherwise, the host needs to statically configure the mapping between peer’s IPv4 address and the AID:EphID pair into the gateway.

In the above client-server communication example, one may argue that the host privacy of the server is lost since its IPv4

address is registered in DNS. To overcome such privacy loss, the IPv4 address can be removed from the DNS record. When the client’s gateway sees the DNS reply, it generates and appends a random IPv4 address into the DNS reply. Then, based on the destination IPv4 address in the client’s packets to the server, the gateway determines the AID:EphID of the server.

When forwarding an incoming APNA packet from an APNA router to a host, the gateway needs to convert it to an IPv4 packet by choosing appropriate source and destination IPv4 addresses. If the gateway already has the mapping between the APNA flow tuple and the IPv4 flow tuple (*i.e.*, the receiving host has sent an outgoing packet with the IPv4 flow tuple), the gateway uses the IPv4 flow tuple to create the IPv4 packet. If the gateway does not have the mapping, the gateway needs to carefully choose the source and destination IPv4 addresses for the IPv4 packet.

When choosing the source address, the gateway needs to ensure that the host can distinguish between different flows. That is, every APNA flow tuple must be mapped to a unique IPv4 flow tuple. If the gateway uses its IPv4 address as the source address in the IPv4 packet, two different APNA flows may have the same 5-tuple information when they use the same source port number. Alternatively, we define a *virtual end-point* which consists of an IPv4 address (*e.g.*, randomly drawn from a private address space), and the source port number in the transport header in the APNA packet. The gateway assigns unique virtual end-point for each APNA flow, and the IPv4 address of the virtual end-point is used as the source IPv4 address in the IPv4 packet.

To determine the destination IPv4 address, the gateway uses the destination EphID information in the APNA header. However, the mapping between EphID and IPv4 address exists only if the destination has sent an outgoing packet or the destination host has registered the mapping between its EphID and IPv4 address. For example, a server administrator registers a (receive-only EphID, IP address)-tuple to his gateway after registering his domain information in DNS.

## VIII. DISCUSSION

### A. Ephemeral ID Granularity

Thus far, we have argued that APNA does not impose the granularity at which EphIDs should be used and we have shown that the EphIDs can be generated at high speed (See Section V-A3). In this section, we present four granularities at which EphIDs can be used.

**Per-Flow Ephemeral ID.** This is the typical use case where a host uses different EphIDs for different flows. There are two advantages to per-flow EphIDs. It prevents an observer’s attempt to identify a common sender of multiple flows by inspecting the content of the packets (*i.e.*, APNA header and payload). Shut-off incidents have limited impact on a host. It terminates the flow that uses the reported EphID as the source; however, all other flows remain intact. The disadvantage of this case is that a host needs to acquire and manage EphIDs for every new flow.

**Per-Host Ephemeral ID.** On one end of the spectrum, a host uses a single EphID for all packets. The advantage of this model is that a host only needs to acquire and manage one EphID. However, there are two drawbacks. Since all packets have the same source EphID, all packets are linked to a common sender. Shut-off incident terminate all connections from the host.

**Per-Packet Ephemeral ID:** A host could use different EphIDs per each packet. Hence, it would be difficult to link different packets even to a single flow, providing the strongest privacy guarantee. However, even the destination host cannot demultiplex packets into flows based on the APNA headers in the packets. An additional protocol is necessary to demultiplex packets [23].

**Per-Application Ephemeral ID.** An EphID can be used to represent all packets that are generated by an application or a service that is running on the host. This EphID granularity facilitates managing traffic that are generated by an application. For example, if an AS enforces its hosts to use per-application EphIDs, the AS and its hosts could collaboratively identify malicious applications (*e.g.*, DDoS bot application) that are running at the hosts. The network identifies malicious activities (*e.g.*, creating flooding attacks) to a source EphID and inform the host about the EphID; then the host identifies the application that uses the EphID and takes appropriate actions.

### B. Support for ICMP

In APNA, ICMP is available by default in most cases because the source host can be reached using the source EphID that is present in host’s packets<sup>5</sup>. Hence, using the source EphID in a packet, one can send an ICMP message to the source host.

Sending an ICMP message follows the same procedure as sending a data packet to another host. An entity (*e.g.*, router or host) that wishes to send an ICMP message uses one of its EphID as the source address in the packet and computes the MAC using the shared key with its AS. APNA offers privacy and accountability for the ICMP messages: identity of the entity remains hidden except to its AS, and the packet is authenticated by the AS. Consequently, if an ICMP message is deemed to be faulty by the receiving host, he can hold the ICMP message sender accountable for the message via the AS of the sender.

Unlike data communication between two hosts, however, the payload of ICMP messages are not encrypted. Encrypting the payload is difficult because the ICMP message sender cannot easily obtain the short-lived certificate of the source EphID in the original message that have prompted the ICMP message. One naive approach is to store short-lived certificates of all flows that the (ICMP message) sender sees; however, this approach incurs a lot of storage overhead to the sender.

<sup>5</sup>If the source EphID expires immediately after the packet leaves the source AS, the source EphID becomes invalid. However, we expect such case to occur infrequently.

As our future work, we are exploring ways to encrypt ICMP messages without imposing excessive overhead to the ICMP message sender.

### C. Strengthening the Shutoff Protocol

If designed incorrectly, the shutoff protocol can be abused as a tool to perform DoS attacks against benign hosts. Thus, it is important to correctly identify the entities that are authorized to perform a shut-off.

In Section IV-E, we restricted the authorized parties as the destination host and AS since these are the only two parties that will provably receive the packet based on the APNA header. However, there are proposals to encode the forwarding paths into the packets (e.g., Packet Passport [25], ICING [29], and OPT [22]). When such proposals are combined with our architecture, the list of authorized entities can be extended to include on path-ASes (or their routers), strengthening the shut-off protocol.

### D. Handling Replay Attacks

A malicious entity that aims to “harm” a source host may replay packets of the source. In the short-term, replayed packets may induce shutoff incidents against the source host, disrupting communication of the source; and in the long-term, the AS of the source host may take retributive action against the source host for repeated shutoff incidents.

Replay attacks can be prevented by making every packet unique. That is, a nonce field is added to the APNA header (Figure 7), and a source host puts a unique number for each generated packet. Then, the destination host performs replay detection based on the nonces in the packets and discards all duplicate packets.

Ideally replayed packets should be filtered near replay location, but this requires routers in the network to perform replay detection. Designing a practical in-network replay detection mechanism that does not affect routers’ forwarding performance is not trivial; it is our future work to design such a mechanism.

### E. APNA-as-a-Service

An ISP can offer APNA’s accountability and privacy protection not only to hosts in its network, but also to its downstream (e.g., customer) ASes. In this deployment, a downstream AS can be viewed as a connection-sharing device that provides APNA connections to its hosts. Then the downstream AS can work as a *transparent bridge* or *NAT* to connect its customers to the ISP (See Section VII-B for details).

APNA-as-a-Service offers benefits to both the ISP and the downstream ASes. The ISP can expand its APNA customer base beyond its network. However, note that the ISP can only offer APNA-as-a-Service to ASes whose packets must go through the ISP. This restriction is necessary since the ISP needs to be able to verify all packets that are originating from the downstream ASes to act as the accountability agent. The customer ASes, especially the small ASes that do not have a large number of hosts (i.e., small anonymity set), can

enjoy stronger level of host privacy protection by mixing with customers of other (upstream) ISPs.

However, there are challenges in deploying APNA-as-a-Service. For example, authentication process of the end-hosts become more complicated since the hosts of the downstream AS may need to authenticate remotely. In addition, routing in the downstream ASes become complex, especially for the ASes that are multi-homed (e.g., managing EphIDs). As our future work, we are investigating the challenges associated with offering APNA-as-a-Service.

### F. Interaction with TLS

APNA by design addresses network layer security issues: (1) it prevents source spoofing by imposing strict authentication of packets; and (2) it provides communication privacy by hiding the identities of communicating parties and supporting pervasive end-to-end encryption. However, APNA does not deal with security issues at higher layers (e.g., authenticating domain ownership).

APNA can work in conjunction with security protocols that deal with security issues at higher layers. For example, TLS can be implemented on top of the encrypted end-to-end path between two hosts to perform user authentication. However, not all functionalities of upper layer security protocol may be necessary. For instance, since APNA already provides a secure end-to-end channel between hosts, the mechanism to establish a symmetric shared key for data encryption may be omitted when implementing TLS on top of APNA.

### G. Parameter Considerations

1) *Expiration Time for EphIDs*: There are multiple factors to consider when deciding the expiration time for EphIDs and the associated short-lived certificates: it should be sufficiently long so that an EphID does not expire before the communication that uses the EphID terminates. At the same time, it should be kept short so that EphID does not last long beyond the end of the communication.

If EphIDs are used per flow, the expiration time can be set to 15 minutes as 98% of the flows in the Internet last less than 15 minutes [11]. Alternatively, the EphID Issuance protocol (Section IV-C) can be extended to allow hosts to express their choice of expiration time. For instance, an AS may specify three categories (short-term, medium-term, long-term EphIDs) to accommodate diverse nature of flow duration time.

2) *Managing Revoked EphIDs*: EphIDs can be preemptively revoked before they expire: a host could revoke an EphID that is no longer needed, or an EphID could have been subjected to a shutoff incident. Regardless of the reason for revoking EphIDs, border routers in the ASes need to store a list of revoked EphIDs (i.e., *revoked\_EphIDs* in Figure 4). If there are too many revocations in an AS, it burdens the border routers since the size of the *revoked\_EphIDs* would become large.

There are two ways to manage the size of *revoked\_EphIDs* list. First, since EphIDs will expire over time and packets using expired EphIDs are dropped, the expired EphIDs can be

removed from *revoked\_EphIDs*. Second, if too many EphIDs of a host are revoked, AS should view it as a sign of malicious activity by the host. In such event, AS revokes the HID of the host invalidating all EphIDs that are issued to the host, and AS assigns a new HID to the host. In addition, the AS can contact the host for corrective measures.

Such measures against malicious hosts by the ASes are not radical. Already in today’s Internet, ISPs that participate in Copyright Alert System (CAS) [3] actively take actions against the customers who repetitively upload copyrighted contents illegally: a customer receives warnings up to 6 reported incidents of illegal uploads, and on the 7th incident, his ISP take actions against the customer (*e.g.*, temporarily reduce connection bandwidth, take educational course about copyright laws). In APNA, an AS can set a maximum number of EphIDs that can be preemptively revoked for each host. Then if a host exceeds the maximum number, the AS can take actions against the host.

#### H. Governments and Communication Privacy

Although generally perceived as a threat on communication privacy, there are legitimate reasons for governments to subvert communication privacy (*e.g.*, to monitor terrorist activities). In fact, many governments by law mandate ISPs to keep record of their Internet traffic (*e.g.*, source and destination IP addresses, payload of the packets, etc).

APNA protects communication privacy making mass surveillance difficult; however, at the same time, it allows entities, such as a government, to deanonymize communication when necessary. With the cooperation of an AS, a government can deanonymize the identity of hosts from EphIDs. Furthermore, if the government has cooperation from the ASes in which communicating hosts reside, the AS could decrypt on-going communication by performing a MitM attack. However, the government cannot simply collect packets in the Internet to observe communication since packets are encrypted (*i.e.*, making mass surveillance difficult). In addition, since APNA achieves perfect forward secrecy, governments cannot decrypt all communication of a host, even if after compromising the long-term public key of the host.

### IX. RELATED WORK

Persona [26] is the first proposal to introduce the idea of balancing privacy and accountability at the network layer. The source ISP replaces the IP address of each outgoing packet with another address from an assigned pool. Although this approach hides the source’s identity, it breaks the notion of flow and prevents the destination from demultiplexing connections.

Accountable and Private Internet Protocol (APIP) [30] proposes an architecture that balances accountability and privacy at the network layer. In APIP, the source address in the network header is replaced with the address of an *accountability delegate* that vouches for the source’s packets. The return address can then be specified at a higher layer – invisible from the network – protecting the source’s privacy. Senders are

expected to brief each packet to their accountability delegate such that on-path devices can request a “vouching proof” from the corresponding delegate.

APIP balances privacy and accountability at the network layer, but it comes with certain limitations. APIP’s notion of privacy is limited to sender-flow unlinkability, leaving data privacy and the associated challenges (*e.g.*, key distribution, management, and establishment) unaddressed. Our proposal presents a holistic architecture that addresses these constraints and by default supports data privacy. Furthermore, the design of APIP precludes every packet from being accounted for in the network: it is possible for a malicious host to omit reporting packets to its accountability delegate when the flow for those packets has been “whitelisted”.<sup>6</sup> In APNA, every packet is linked to its sender since a MAC is computed using the shared key between the AS and the host for every packet (Section IV-D). Second, masking the return address complicates getting messages from the network back to the source—the messages must be redirected through the accountability delegate of the source; the complexity of this functionality remains unaddressed. APNA allows the network to send messages directly to the source while preserving host privacy and the accountability properties (Section VIII-B).

**Source Accountability:** The Accountable Internet Protocol (AIP) [4] treats source accountability as a central architectural principle. In AIP, self-certifying IDs and a shutoff protocol (implemented by smart Network Interface Cards) are used to identify and block malicious sources. Our architecture uses self-certifying IDs in an anonymity-preserving way and delegates the shutoff functionality to the source domain.

In Passport [25], OPT [22] and ICING [29], Message Authentication Codes are used for each AS on the end-to-end path, allowing on-path ASes to verify the authenticity of packets.

Bender *et al.* [8] were first to introduce the concept of accountability agents in their Accountability-as-a-Service (AaaS) proposal. However, AaaS does not address privacy considerations and requires symmetric keys between all AS pairs.

**Host Privacy and Anonymity:** Raghavan *et al.* [33] propose ISP-wide NATs to hide the hosts’ identities from entities in other ASes. We borrow their motivation that the size of today’s large ISPs provides sufficiently large anonymity sets. Onion routing [34] and Mix Networks [12] by design provide source anonymity at the cost of source accountability.

Han *et al.* [17] propose a cross-layer design that uses pseudonyms to hide the user’s identity. Similar to APNA, the proposal allows the user to choose the level of anonymity and it uses encryption to mask the identity of the host in network addresses. However, the proposal falls short of being a complete architecture that balances between accountability and privacy: it does not consider pervasive data encryption and

<sup>6</sup>Verifiers do not verify flows that have been “whitelisted,” and a sender does not brief packets unless it is asked by its accountability delegate under the recursive verification method (Section 5 in APIP [30]).

the associated challenges, such as certificate management, and does not consider source accountability.

**Data Privacy:** Farrell and Tschofenig [15] argue that pervasive monitoring – defined as the widespread and often covert surveillance through intrusive gathering of communication information – is a widespread attack on privacy. In response, Kent [20] proposes pervasive encryption as a countermeasure against pervasive monitoring. In a related effort, the Let’s Encrypt<sup>7</sup> organization encourages the use of encrypted web traffic by issuing free TLS certificates for web servers. Our proposal does not replace transport-layer encryption, but rather promotes pervasive encryption to a fundamental design tenet of the network layer. In addition, we propose a concrete solution for key distribution, establishment, and management.

MinimalT [31] proposes an architecture that supports pervasive data encryption and achieves PFS at low latency; however, MinimalT does not consider source accountability. In Section IV-D1, we show how our architecture supports data privacy with PFS while enforcing source accountability.

## X. CONCLUSIONS

We propose APNA, an architecture that resolves the accountability-privacy tussle by enlisting ISPs as accountability agents and privacy brokers. As accountability agents, ISPs authenticate hosts and their packets into the network; and as privacy brokers, ISPs anonymize the identities of communicating parties and assist in the establishment of shared keys for end-to-end data encryption.

By facilitating (and by enabling by default) pervasive encryption between endpoints, APNA can help frustrate adversaries conducting indiscriminate mass surveillance. At the same time, APNA can assist in lawful, targeted request for subscriber communications, since ISPs can comply with data retention laws by storing customer to EphID bindings as well as the packets. However, abuse of such requests for information are minimized due to the perfect forward secrecy of our scheme: even if host’s public key is compromised, the secrecy and integrity of previous communications remain untouched.

## REFERENCES

- [1] “Data Plane Development Kit,” <http://dpdk.org>, retrieved on 1/2016.
- [2] “Spirent SPT-N4U-220 Chassis,” [http://www.spirent.com/Ethernet\\_Testing/Platforms/N4U\\_Chassis](http://www.spirent.com/Ethernet_Testing/Platforms/N4U_Chassis), retrieved on 4/2016.
- [3] “The Copyright Alert System,” retrieved on 12/2015. [Online]. Available: <http://www.copyrightinformation.org/the-copyright-alert-system>
- [4] D. G. Andersen, H. Balakrishnan, N. Feamster, T. Koponen, D. Moon, and S. Shenker, “Accountable Internet Protocol (AIP),” in *Proceedings of ACM Conference on SIGCOMM*, 2008.
- [5] ARIN, “Resource Public Key Infrastructure,” <http://bit.ly/1EJCQoT>, retrieved on 2/2016.
- [6] M. Bellare, J. Kilian, and P. Rogaway, “The Security of the Cipher Block Chaining Message Authentication Code,” *Journal of Computer and System Science*, vol. 61, no. 3, pp. 362–399, 2001.
- [7] M. Bellare and C. Namprempe, “Authenticated Encryption: Relations among Notions and Analysis of the Generic Composition Paradigm,” in *Advances in Cryptology—ASIACRYPT*, vol. 1976. Springer, 2000, pp. 531–545.
- [8] A. Bender, N. Spring, D. Levin, and B. Bhattacharjee, “Accountability as a Service,” in *Proceedings of USENIX Workshop on Steps to Reducing Unwanted Traffic (SRUTI)*, 2007.
- [9] D. J. Bernstein, “Curve25519: new Diffie-Hellman speed records,” in *Public Key Cryptography (PKC)*. Springer, 2006.
- [10] D. J. Bernstein, N. Duif, T. Lange, P. Schwabe, and B.-Y. Yang, “High-speed high-security signatures,” *Journal of Cryptographic Engineering*, vol. 2, no. 2, 2012.
- [11] N. Brownlee and K. Claffy, “Understanding Internet Traffic Streams: Dragonflies and Tortoises,” *Communication Magazine, IEEE*, vol. 40, no. 10, pp. 110–117, 2002.
- [12] D. L. Chaum, “Untraceable Electronic Mail, Return Addresses, and Digital Pseudonyms,” *Communications of the ACM*, vol. 24, no. 2, 1981.
- [13] V. Fajardo, J. Arkko, J. Loughney, and G. Zorn, “Diameter Base Protocol,” RFC 6733 (Proposed Standard), Internet Engineering Task Force, Oct. 2012, updated by RFC 7075. [Online]. Available: <http://www.ietf.org/rfc/rfc6733.txt>
- [14] D. Farinacci, T. Li, S. Hanks, D. Meyer, and P. Traina, “Generic Routing Encapsulation (GRE),” RFC 2784 (Proposed Standard), Internet Engineering Task Force, Mar. 2000, updated by RFC 2890. [Online]. Available: <http://www.ietf.org/rfc/rfc2784.txt>
- [15] S. Farrell and H. Tschofenig, “Pervasive Monitoring Is an Attack,” RFC 7258 (Best Current Practice), Internet Engineering Task Force, May 2014. [Online]. Available: <http://www.ietf.org/rfc/rfc7258.txt>
- [16] S. Gueron, “Intel Advanced Encryption Standard (AES) New Instruction Set,” Mar 2010. [Online]. Available: <https://software.intel.com/sites/default/files/article/165683/aes-wp-2012-09-22-v01.pdf>
- [17] S. Han, V. Liu, Q. Pu, S. Peter, T. Anderson, A. Krishnamurthy, and D. Wetherall, “Expressive Privacy Control with Pseudonyms,” in *Proceedings of ACM conference on SIGCOMM*, 2013.
- [18] M. Jaber, R. G. Cascella, and C. Barakat, “Can we trust the inter-packet time for traffic classification?” in *Proceedings of IEEE Conference on Communications*, 2011.
- [19] C. Kaufman, “Internet Key Exchange (IKEv2) Protocol,” RFC 4306 (Proposed Standard), Internet Engineering Task Force, Dec. 2005, obsolete by RFC 5996, updated by RFC 5282. [Online]. Available: <http://www.ietf.org/rfc/rfc4306.txt>
- [20] S. Kent, “Pervasive Encryption as a Countermeasure to Pervasive Monitoring,” draft-kent-pervasive-encryption-00, Internet Engineering Task Force, Sep. 2014.
- [21] S. Kent and K. Seo, “Security Architecture for the Internet Protocol,” RFC 4301 (Proposed Standard), Internet Engineering Task Force, Dec. 2005, updated by RFC 6040. [Online]. Available: <http://www.ietf.org/rfc/rfc4301.txt>
- [22] T. H.-J. Kim, C. Basescu, L. Jia, S. B. Lee, Y.-C. Hu, and A. Perrig, “Lightweight Source Authentication and Path Validation,” in *Proceedings of ACM Conference on SIGCOMM*, 2014.
- [23] T. Lee, C. Pappas, P. Szalachowski, and A. Perrig, “Communication Based on Per-Packet One-Time Address,” in *Proceedings of IEEE Conference on Network Protocols (ICNP)*, 2016.
- [24] D. G. Lichtman, “Holding Internet Service Providers Accountable,” *University of Chicago Coase-Sandor Working Paper Series in Law and Economics*, 2004.
- [25] X. Liu, A. Li, X. Yang, and D. Wetherall, “Passport: Secure and Adoptable Source Authentication,” in *Proceedings of USENIX Conference on Networked Systems Design and Implementation (NSDI)*, 2008.
- [26] Y. Mallios, S. Modi, A. Agarwala, and C. Johns, “Persona: Network Layer Anonymity and Accountability for Next Generation Internet,” *IFIP Advances in Information and Communication Technology*, vol. 297, pp. 410–420, 2009.
- [27] D. A. McGrew and J. Viega, “The Galois/Counter Mode of Operation (GCM),” 2004. [Online]. Available: <http://csrc.nist.gov/groups/ST/toolkit/BCM/documents/proposedmodes/gcm/gcm-spec.pdf>
- [28] A. J. Menezes, P. C. v. Oorschot, and S. A. Vanstone, *Handbook of Applied Cryptography*, fifth printing ed. CRC Press, 2001.
- [29] J. Naous, M. Walfish, A. Nicolosi, D. Mazières, M. Miller, and A. Seehra, “Verifying and enforcing network paths with ICING,” in *Proceedings of ACM Conference on Emerging Networking EXperiments and Technologies (CoNEXT)*, 2011.
- [30] D. Naylor, M. K. Mukerjee, and P. Steenkiste, “Balancing Accountability and Privacy in the Network,” in *Proceedings of ACM Conference on SIGCOMM*, 2014.
- [31] M. W. Petullo, X. Zhang, J. A. Solworth, D. J. Bernstein, and T. Lange, “MinimalT: Minimal-latency Networking Through Better Security,” in

<sup>7</sup><https://letsencrypt.org>



*Proceedings of ACM SIGSAC Conference on Computer & Communications Security (CCS)*, 2013.

- [32] A. Pfitzmann and M. Hansen, "Anonymity, Unobservability, and Pseudonymity: A Consolidated Proposal for Terminology," Jul 2000. [Online]. Available: [http://dud.inf.tu-dresden.de/Anon\\_Terminology.shtml](http://dud.inf.tu-dresden.de/Anon_Terminology.shtml)
- [33] B. Raghavan, T. Kohno, A. C. Snoeren, and W. David, "Enlisting ISPs to improve online privacy: IP Address Mixing by Default," in *Proceedings of Privacy Enhancing Technologies Symposium (PETS)*, 2009.
- [34] M. G. Reed, P. F. Syverson, and D. M. Goldschlag, "Anonymous Connections and Onion Routing," *Selected Areas in Communications, IEEE Journal on*, vol. 16, no. 4, 1998.
- [35] C. Rigney, S. Willens, A. Rubens, and W. Simpson, "Remote Authentication Dial In User Service (RADIUS)," RFC 2865 (Draft Standard), Internet Engineering Task Force, Jun. 2000, updated by RFCs 2868, 3575, 5080, 6929. [Online]. Available: <http://www.ietf.org/rfc/rfc2865.txt>
- [36] P. Rogaway, M. Bellare, and J. Black, "OCB: A block-cipher mode of operation for efficient authenticated encryption," *Information and System Security (TISSEC), ACM Transactions on*, vol. 6, no. 3, pp. 365–403, 2003.
- [37] B. Rowe, D. Wood, D. Reeves, and F. Braun, "The Role of Internet Service Providers in Cyber Security," 2011. [Online]. Available: [http://sites.duke.edu/ihs/files/2011/12/ISP-Provided\\_Security-Research-Brief\\_Rowe.pdf](http://sites.duke.edu/ihs/files/2011/12/ISP-Provided_Security-Research-Brief_Rowe.pdf)