

Layering of Communication Networks and a Forward-Backward Duality

Michael Cyran¹, Birgit Schotsch², Johannes B. Huber¹, Robert F.H. Fischer³, Vahid Forutan³

¹Lehrstuhl für Informationsübertragung, Friedrich-Alexander-Universität Erlangen-Nürnberg, Erlangen, Germany

²Airbus DS GmbH, Munich, Germany

³Institut für Nachrichtentechnik, Universität Ulm, Ulm, Germany

michael.cyran@fau.de, birgit.schotsch@airbus.com, johannes.huber@fau.de,
robert.fischer@uni-ulm.de, vahid.forutan@uni-ulm.de

Abstract—In layered communication networks there are only connections between intermediate nodes in adjacent layers. Applying network coding to such networks provides a number of benefits in theory as well as in practice. We propose a *layering procedure* to transform an arbitrary network into a layered structure. Furthermore, we derive a *forward-backward duality* for linear network codes, which can be seen as an analogon to the *uplink-downlink duality* in MIMO communication systems.

I. INTRODUCTION

In [1] it was shown that communication between two nodes within a communication network is possible up to a rate that is equal to the minimum rate flowing through any possible cut between these two nodes—the *mincut* between them. This rate can be achieved by allowing intermediate nodes to *code*, i.e., to calculate functions of their incoming messages before forwarding them. In [2] it was proved that it suffices to apply *linear network coding* (LNC), i.e., intermediate nodes just need to form *linear* combinations of their received messages from a finite field \mathbb{F}_q . If all operations are performed over a finite field of large enough size q , the factors at the intermediate nodes may even be drawn independently at random, which leads to a robust, decentralized, and capacity achieving approach: *random linear network coding* (RLNC) [3], [4].

This paper studies network coding (NC) in *layered networks*, where intermediate nodes are arranged in layers and there exist only edges between nodes which are located in adjacent layers. We introduce a *layering procedure* for establishing a layered structure in seemingly disparate and unstructured network topologies. Applying NC to a layered network provides a number of benefits in theory for analysis as well as in practice. Moreover, we address the problem of *bidirectional NC* and derive a *forward-backward duality*.

The paper is organized as follows: Sec. II gives a brief recapitulation and a classification of NC. In Sec. III we examine layered networks and introduce the *layering procedure*. *Bidirectional NC* is discussed in Sec. IV and some conclusions are drawn in Sec. V.

II. BRIEF RECAPITULATION OF NETWORK CODING

A. Problem Formulation

We define a communication network as a directed, acyclic graph $\mathcal{G} = \{\mathcal{N}, \mathcal{E}\}$ with a set of nodes \mathcal{N} and a set of edges \mathcal{E} . The considered *multicast scenario* consists of a unique source node $S \in \mathcal{N}$ with n outgoing edges, and K destination nodes D_k , $k = 1, \dots, K$, with $N_k \geq n$ incoming edges. The

source transmits n symbols $x_1, \dots, x_n \in \mathbb{F}_q$ to each of the destination nodes D_k by injecting these n symbols in parallel (one on each of its outgoing edges) into the network and each destination node D_k tries to reconstruct all these symbols from its N_k receive symbols $y_{k,1}, \dots, y_{k,N_k} \in \mathbb{F}_q$. Nodes within the network are connected by edges $e_{i,j} = (N_i, N_j) \in \mathcal{E}$. Each edge represents a noiseless¹ communication link on which one symbol from \mathbb{F}_q can be transmitted per usage. We further assume that each edge induces the same delay.² The in-degree d_i^{in} and the out-degree d_i^{out} of a node N_i is defined as the number of its incoming and outgoing edges, respectively. Coding at intermediate nodes is accomplished as follows: each node N_i collects the symbols from each of its d_i^{in} incoming edges. Then, it computes possibly different functions of these symbols and transmits them on its d_i^{out} outgoing edges.

B. Classification of Network Coding Variants

Essentially, there exist two distinct approaches to generate outgoing messages at intermediate nodes. In the first one, which we denote as NC Variant I, each intermediate node calculates only a single function of its input symbols and transmits the resulting output symbol on all outgoing edges. This variant is applicable, e.g., in wireless networks, where intermediate nodes possess omnidirectional antennas, and thus, transmit a single signal. In NC Variant II intermediate nodes compute *individual* output symbols for their outgoing edges. This variant can be applied, e.g., in wired networks. In Fig. 1(a) an intermediate node N_i with d_i^{in} incoming and d_i^{out} outgoing edges is depicted. The incoming and the outgoing symbols of node N_i are denoted as $z_{i,\delta}^{\text{in}}$, $\delta = 1, \dots, d_i^{\text{in}}$, and $z_{i,\rho}^{\text{out}}$, $\rho = 1, \dots, d_i^{\text{out}}$, respectively. The two NC variants are closely related to each other. This is specified in the following theorem and is illustrated in Fig. 1.

Theorem 1 *A communication network employing NC Variant II can be transformed into an equivalent network which applies NC Variant I, by splitting up each intermediate node N_i with d_i^{out} outgoing edges into d_i^{out} single output auxiliary nodes. These auxiliary nodes possess the same input edges as the original node N_i .*

Proof: A Variant-II node N_i is split up into d_i^{out} auxiliary single output nodes $N_{i,j}$, $j = 1, \dots, d_i^{\text{out}}$, cf. Fig. 1(b). By repeating this procedure for all Variant-II nodes results in an equivalent NC Variant I network. ■

¹Since we do not treat error-correction coding for networks in this paper, we restrict ourselves to the case of error-free NC. However, all statements contained in this paper are also applicable for noisy networks.

²If this is not the case, equal-delay edges can be achieved through appropriate buffers at the intermediate nodes.

This work was supported by DFG under grants FI 982/4-3 and HU 634/11-3, and by BMBF under grant 16 BP 12406.

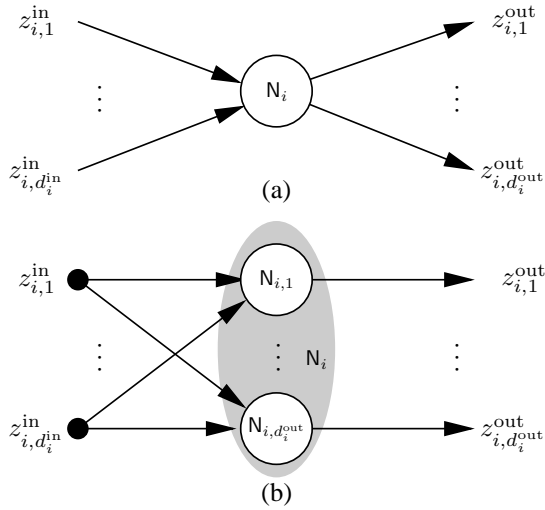

Figure 1. Illustration of Theorem 1: Conversion of a node N_i which applies NC Variant II (a) into d_i^{out} single output nodes $N_{i,1}, \dots, N_{i,d_i^{\text{out}}}$ (b).

Hybrid forms of these two variants are also possible, if a node N_i transmits $h < d_i^{\text{out}}$ distinct messages. Such a variant is possible, e.g., in wireless networks, where intermediate nodes possess several directional antennas and transmit distinct messages in distinct directions. These hybrid variants can also be transformed into NC Variant I by splitting up nodes which transmit h different messages into h auxiliary nodes.

Obviously, the mincut of a network can only be achieved by applying NC Variant II. However, for analysis the equivalent NC Variant I representation is more convenient, as will be shown in the remainder of this paper.

C. Linear Network Coding

In LNC the outgoing messages $z_{i,\rho}^{\text{out}}$ at a node N_i are \mathbb{F}_q -linear combinations of their incoming messages $z_{i,\delta}^{\text{in}}$

$$z_{i,\rho}^{\text{out}} = \sum_{\delta=1}^{d_i^{\text{in}}} c_{i,\delta,\rho} \cdot z_{i,\delta}^{\text{in}}, \quad \rho = 1, \dots, d_i^{\text{out}}, \quad (1)$$

where $c_{i,\delta,\rho} \in \mathbb{F}_q$ are the *linear coding coefficients* at node N_i . If NC Variant I is applied, all outgoing symbols are equal, i.e., $z_{i,\rho}^{\text{out}} = z_{i,1}^{\text{out}} = \dots = z_{i,d_i^{\text{out}}}^{\text{out}}$, and thus, $c_{i,\delta,\rho} = c_{i,\delta}, \forall \rho$, whereas in NC Variant II these quantities are different.

Let $\mathbf{z}_i^{\text{in}} \in \mathbb{F}_q^{d_i^{\text{in}}}$ and $\mathbf{z}_i^{\text{out}} \in \mathbb{F}_q^{d_i^{\text{out}}}$ be the vectors of incoming and outgoing symbols at node N_i , respectively. We can write (1) in vector-matrix notation as

$$\mathbf{z}_i^{\text{out}} = \mathbf{C}_i \mathbf{z}_i^{\text{in}}, \quad (2)$$

where $\mathbf{C}_i \in \mathbb{F}_q^{d_i^{\text{out}} \times d_i^{\text{in}}}$ is the *coefficient matrix* of node N_i

$$\mathbf{C}_i = \begin{bmatrix} c_{i,1,1} & \cdots & c_{i,d_i^{\text{in}},1} \\ c_{i,1,2} & \cdots & c_{i,d_i^{\text{in}},2} \\ \vdots & \ddots & \vdots \\ c_{i,1,d_i^{\text{out}}} & \cdots & c_{i,d_i^{\text{in}},d_i^{\text{out}}} \end{bmatrix}, \quad (3)$$

In NC Variant I the columns of \mathbf{C}_i are restricted to one element ($c_{i,\delta,\rho} = c_{i,\delta}, \forall \rho$), whereas in NC Variant II the columns consist of individual entries.

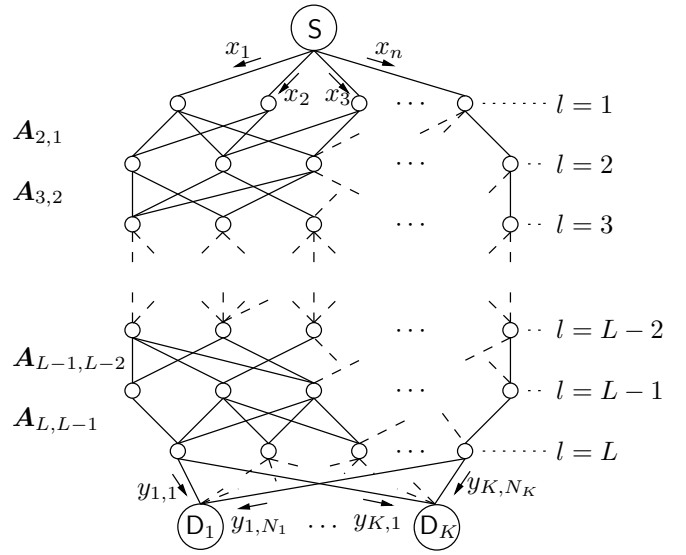

Figure 2. Exemplary layered network with L layers, one source node S , and K destination nodes D_k (multicast scenario).

Since each intermediate node performs linear coding, the resulting receive vector $\mathbf{y}_k = [y_{k,1}, \dots, y_{k,N_k}]^T \in \mathbb{F}_q^{N_k}$ is still a linear transformation of the source vector $\mathbf{x} = [x_1, \dots, x_n]^T \in \mathbb{F}_q^n$, i.e., the network between source S and destination D_k acts as a linear map $\mathbb{F}_q^n \rightarrow \mathbb{F}_q^{N_k}$ which is represented by the *individual network channel matrix* $\mathbf{A}_k \in \mathbb{F}_q^{N_k \times n}$. The elements $a_{i,j}$ of this matrix represent the corresponding *route gains*, i.e., $a_{i,j}$ is the gain of the route from the j th outgoing edge of the source node S to the i th incoming edge of destination node D_k . These route gains are sums of products of the coding coefficients $c_{i,\delta,\rho}$. The end-to-end model for a $S \rightarrow D_k$ link is given by

$$\mathbf{y}_k = \mathbf{A}_k \mathbf{x}. \quad (4)$$

D_k is able to reconstruct \mathbf{x} if \mathbf{A}_k has full column rank n . We speak of a *valid NC* in this case.

III. LAYERING

A. Layered Networks

In a layered network all intermediate nodes are arranged in L layers. Nodes in layer l only receive packets from nodes in layer $l-1$, i.e., there are no connections between non-adjacent layers and no connections between nodes within the same layer. In Fig. 2 a layered network with one source node S and K destination nodes $D_k, k = 1, \dots, K$, is depicted. The number of nodes in layer l is denoted as n_l , with $n_1 = n$ and $n_L \geq \max_k(N_k)$. For the unicast scenario, i.e., if there is only one destination node D , $n_L = N$ holds.

Such networks exhibit a number of beneficial properties of which two are particularly noteworthy.

- 1) A layered network is inherently time synchronized. All symbols arrive simultaneously at a specific intermediate node. Consequently, each intermediate node can immediately code its incoming symbols and does not have to wait until all required symbols arrive.
- 2) It enables a factorization of the individual network channel matrices \mathbf{A}_k (cf. Sec. III-B). This is the basis for the

derivation of the *forward-backward duality* for LNC (cf. Sec. IV).

B. Linear Network Coding in Layered Networks

When linear NC Variant I is applied,³ the *overall network channel matrix* \mathbf{A} , i.e., the linear transformation from layer 1 to layer L , can be obtained as the product of all $L-1$ *interlayer matrices* $\mathbf{A}_{l+1,l} \in \mathbb{F}_q^{n_{l+1} \times n_l}$

$$\mathbf{A} = \mathbf{A}_{L,L-1} \cdot \mathbf{A}_{L-1,L-2} \cdots \mathbf{A}_{2,1} = \prod_{l=1}^{L-1} \mathbf{A}_{l+1,l}. \quad (5)$$

These interlayer matrices consist of the linear factors associated with the edges that connect the corresponding layers. The element in the i th row and the j th column of $\mathbf{A}_{l+1,l}$ represents the linear factor corresponding to the edge which connects the j th node in layer l with the i th node in layer $l+1$. The connection between the interlayer matrices and the coefficient matrices is as follows. $\mathbf{A}_{l+1,l}$ contains the coding coefficients of the coefficient matrices \mathbf{C}_i which correspond to the intermediate nodes in layer $l+1$. In addition to that, the interlayer matrices imply the wiring between the two affected layers, whereas the coefficient matrices merely describe the operations at one specific node. To sum up, $\mathbf{A}_{l+1,l}$ is an *edge-oriented* description of the LNC, which takes also the topology into account, and \mathbf{C}_i is a local, *node-oriented* description.

The *individual network channel matrix* \mathbf{A}_k corresponding to destination node D_k , $k = 1, \dots, K$, consists of a subset \mathcal{D}_k of rows⁴ of \mathbf{A}

$$\mathbf{A}_k = \mathbf{A}(\mathcal{D}_k, :), \quad (6)$$

where \mathcal{D}_k is the subset of rows, which correspond to the nodes in the last layer, to which the destination node D_k is connected. In case of the unicast scenario, the individual network channel matrix is equal to the overall network channel matrix \mathbf{A} .

The factorization (5) enables a simple method to determine an upper bound on the mincut between the source and a destination:

Theorem 2 *The mincut between the source S and a destination node D_k in a layered network is*

$$\begin{aligned} \text{mincut}(S, D_k) &= \max_{\substack{c_i, \delta, \rho \in \mathbb{F}_q \\ q > K}} (\text{rank}(\mathbf{A}_k)) \\ &\leq \min_l \left(\max_{\substack{c_i, \delta, \rho \in \mathbb{F}_q \\ q > K}} (\text{rank}(\mathbf{A}_{l+1,l})) \right). \end{aligned} \quad (7)$$

Proof: The mincut between S and D_k is the number of symbols which can be reliably transmitted from S to D_k , and thus, is equal to the rank of the individual network channel matrix. Since the individual network channel matrix is the product of the corresponding inter-layer matrices, the minimal rank of the inter-layer matrices is an upper bound on the mincut between S and D_k . The finite field size q has to be greater than the number of destinations K [10]. ■

³If the network nodes apply NC Variant II, the network can be transformed into an equivalent network which applies NC Variant I (cf., Theorem 1), and the factorization of the channel matrix has to be accomplished for the equivalent network.

⁴We adopt the Matlab notation, i.e., $\mathbf{A}(\mathcal{A}, \mathcal{B})$, represents a matrix composed of a subset \mathcal{A} of the rows and a subset \mathcal{B} of the columns of \mathbf{A} .

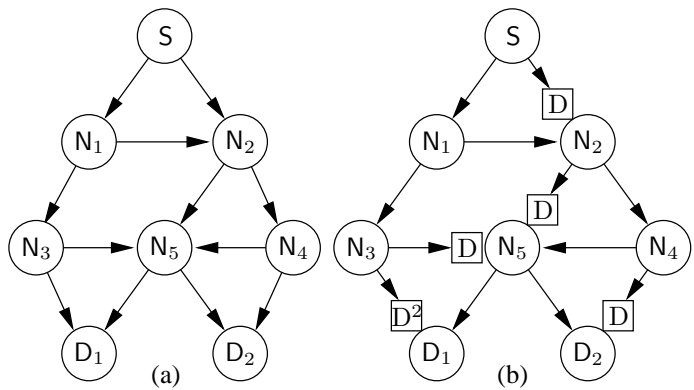

Figure 3. Non-layered network with one source, two destinations, and five intermediate nodes. Without (a), and with depicted delay elements (b).

C. Layering of Arbitrary Networks

In a non-layered network paths from the source node to the destination nodes consist of different numbers of edges i.e., have different “lengths”. An exemplary non-layered network is depicted in Fig. 3(a). Obviously, there are paths from S to D_k ($k = 1, 2$) of different lengths, e.g., $S \rightarrow N_1 \rightarrow N_3 \rightarrow D_1$ and $S \rightarrow N_1 \rightarrow N_2 \rightarrow N_4 \rightarrow N_5 \rightarrow D_1$ consisting of three and five edges, respectively. The aim of our proposed procedure, which we denote as *layering*, is to force all paths from the source to all of the destinations to have the same length, namely $L+1$.

For that, consider the *coding points*, i.e., the nodes which receive more than one symbol. The first coding point in our exemplary network in Fig. 3(a) is N_2 , which receives a packet from S after one time unit, and a packet from N_1 after two time units. To be able to code, i.e., to create a function of these two packets, N_2 has to buffer the packet received from S for one time unit. This buffer, which actually is part of N_2 , can formally be redrawn outside of N_2 . We continue this step for all coding points in $\mathcal{G}\{\mathcal{N}, \mathcal{E}\}$ and obtain the network depicted in Fig. 3(b). A delay of s time units is denoted as D^s . Finally, we interpret these delay elements as single-input/single-output (SISO) nodes, which just pass the packet received on their incoming edge to their outgoing edge. Delays of s time units are interpreted as s consecutive SISO nodes. Basically, layering consists of two steps:

- 1) Enumerate all intermediate network nodes according to an ancestral ordering⁵, i.e., if $e_{i,j} \in \mathcal{E}$ then $i < j$.
- 2) Visit all coding points sequentially and introduce SISO nodes, such that all paths which meet in one point have the same length.

After redrawing the network, we obtain the layered structure depicted in Fig. 4, where the introduced SISO nodes are depicted in gray. This layered network with $L = 4$ layers is equivalent to the network depicted in Fig. 3(a). Since each coding point has to be visited exactly once, the complexity of this algorithm is of order $\mathcal{O}(N_{cp} \cdot \bar{d}_{cp}^n)$, where N_{cp} is the number of coding points and \bar{d}_{cp}^n is the average number of incoming edges of the coding points. We summarize this insight in the following theorem.

⁵Such an ordering exists for all acyclic networks [5].

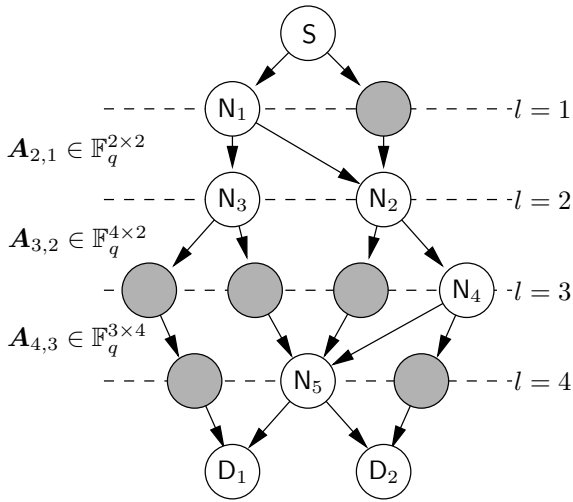

Figure 4. Communication network from Fig. 3 in layered representation.

Theorem 3 *Despite the actual structure of an acyclic network, an equivalent layered network can be obtained by introducing additional redundant SISO nodes, such that all paths from the source to any destination consist of the same number of edges.*

The factorization (5) of \mathbf{A} can be accomplished together with the layering procedure: During the layering procedure the nodes are assigned to layers and the wiring between the layers can be obtained from the set of edges \mathcal{E} .

We speak of a *layered Variant I representation* of an arbitrary network if it was layered according to Theorem 3 and transformed to Variant I according to Theorem 1. In [6] we already exploited the layered Variant I representation of communication networks in the context of RLNC. With the aid of the factorized version of the network channel matrix (5) we derived in [6] the probability distribution of the entries of \mathbf{A} and an upper bound on the outage probability of random linear network codes with known incidence matrices. A further consequence of the layered Variant I representation is a new possibility of the determination of an upper bound on the mincut of acyclic networks in two steps:

- 1) Layering of the network and a Variant II to Variant I conversion if necessary.
- 2) Determination of the mincut according to Theorem 2.

IV. BIDIRECTIONAL NETWORK CODING

Up to now, we have considered a unidirectional communication from the source node S to one or several destination nodes D_k . In this section, we address the problem of a bidirectional communication between a source-destination pair, i.e., the case where a destination node D_k replies to the source node S , which is of interest, e.g., in optical (fiber-optical) networks. For the moment, we assume that $N_k = n$, i.e., that the individual network channel matrix \mathbf{A}_k is square. Furthermore, for notational convenience, we drop the index k and denote the considered individual network channel matrix as \mathbf{A} .

When we reverse the direction of communication, it is reasonable to reverse the operations at the intermediate nodes, as depicted in Fig. 5 for the case of a node with two incoming

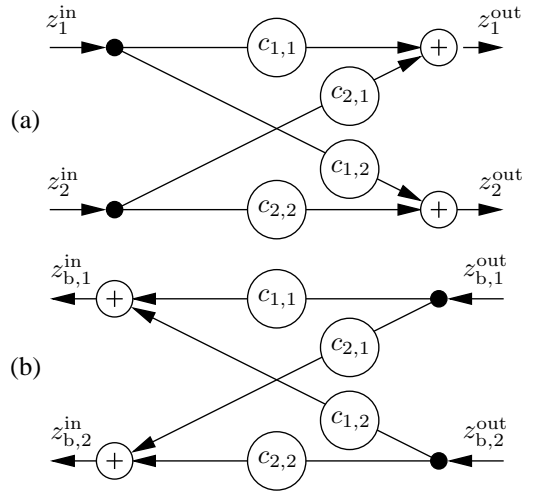

Figure 5. Exemplary intermediate node with two incoming and two outgoing edges in forward (a) and backward (b) direction.

and two outgoing edges. In the backward direction, not only the direction of communication is reversed, also the summing and the distribution points are interchanged. The input-output relation of this exemplary node by means of the coefficient matrices (3) for the *forward direction* is

$$\begin{bmatrix} z_1^{\text{out}} \\ z_2^{\text{out}} \end{bmatrix} = \underbrace{\begin{bmatrix} c_{1,1} & c_{2,1} \\ c_{1,2} & c_{2,2} \end{bmatrix}}_{\mathbf{C}_i} \begin{bmatrix} z_1^{\text{in}} \\ z_2^{\text{in}} \end{bmatrix}, \quad (8)$$

whereas for the *backward direction* we obtain

$$\begin{bmatrix} z_{b,1}^{\text{out}} \\ z_{b,2}^{\text{out}} \end{bmatrix} = \underbrace{\begin{bmatrix} c_{1,1} & c_{1,2} \\ c_{2,1} & c_{2,2} \end{bmatrix}}_{\mathbf{C}_{b,i}} \begin{bmatrix} z_{b,1}^{\text{in}} \\ z_{b,2}^{\text{in}} \end{bmatrix}, \quad (9)$$

i.e., if we retain the coding coefficients and reverse the operations at an intermediate node N_i , the coefficient matrix $\mathbf{C}_{b,i}$ for the backward direction is the transpose of the coefficient matrix \mathbf{C}_i for the forward direction

$$\mathbf{C}_{b,i} = \mathbf{C}_i^T. \quad (10)$$

The consequence for the individual network channel matrix is stated in the following theorem.

Theorem 4 *The individual network channel matrix \mathbf{A}_b for the backward direction in networks which apply LNC is equal to the transpose of the network channel matrix \mathbf{A} for the forward direction*

$$\mathbf{A}_b = \mathbf{A}^T, \quad (11)$$

given that the coding coefficients are retained, and the operations at the intermediate nodes are reversed.

Proof: Consider a layered Variant I representation of an arbitrary network which applies LNC. We first investigate the effects of the reversion of the communication direction on the inter-layer matrices. For that, consider the two adjacent layers depicted in Fig. 6(a). The inter-layer matrix for the forward

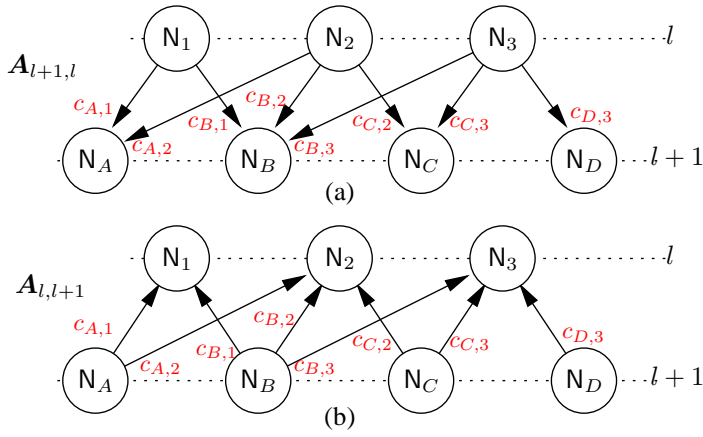

Figure 6. Two exemplary layers of a communication network in forward (a) and in backward (b) direction.

direction $\mathbf{A}_{l+1,l}$ results in

$$\mathbf{A}_{l+1,l} = \begin{bmatrix} c_{A,1} & c_{A,2} & 0 \\ c_{B,1} & c_{B,2} & c_{B,3} \\ 0 & c_{C,2} & c_{C,3} \\ 0 & 0 & c_{D,3} \end{bmatrix}. \quad (12)$$

If we reverse the processing at the nodes as described above and retain the coding coefficients, the coefficient which corresponded to edge $e_{i,j}$, now corresponds to the reversed edge $e_{j,i}$, cf. Fig. 6(b). Due to the fact that the roles of the layers are interchanged (i.e., the “transmitting” layer is now the “receiving” layer and vice versa) the inter-layer matrix for the backward direction $\mathbf{A}_{l,l+1}$ is the transposed version of the one for the forward direction

$$\mathbf{A}_{l,l+1} = \begin{bmatrix} c_{A,1} & c_{B,1} & 0 & 0 \\ c_{A,2} & c_{B,2} & c_{C,2} & 0 \\ 0 & c_{B,3} & c_{C,3} & c_{D,3} \end{bmatrix} = \mathbf{A}_{l+1,l}^T. \quad (13)$$

Inserting this into (5) yields

$$\begin{aligned} \mathbf{A}_b &= \mathbf{A}_{1,2} \cdot \mathbf{A}_{2,3} \cdots \mathbf{A}_{L-1,L} \\ &= \mathbf{A}_{2,1}^T \cdot \mathbf{A}_{3,2}^T \cdots \mathbf{A}_{L,L-1}^T \\ &= (\mathbf{A}_{L,L-1} \cdots \mathbf{A}_{3,2} \cdot \mathbf{A}_{2,1})^T \\ &= \mathbf{A}^T. \end{aligned} \quad (14)$$

Theorem 4 can be seen as an analogon to the famous *uplink-downlink duality* from MIMO communications, e.g., [7], which states that the channel matrix \mathbf{H}_u for the uplink is equal to the Hermitian transpose of the channel matrix \mathbf{H}_d for the downlink, i.e., $\mathbf{H}_u = \mathbf{H}_d^H$ (in the complex baseband).

If $N_k > n$, the “reverse source” node D_k has more outgoing edges than the “reverse destination” node S incoming ones. As a consequence, the “reverse source” D_k cannot simply transmit N_k individual transmit symbols. Rather, we have to force \mathbf{A} to be square, by selecting n linearly independent rows and deleting the remaining $N_k - n$ ones. In the graph \mathcal{G} this corresponds to deleting the corresponding $N_k - n$ incoming edges of D_k . Another possibility to resolve the problem of having too many outgoing edges at the “reverse source” is the application of *precoding* [9], which is denoted as *coding at the source* [8] in the context of NC. Then, the “reverse source”

transmits n individual transmit symbols and $N_k - n$ linear combinations of them.

The consequence of Theorem 4 on the validity of the linear network code is as follows.

Theorem 5 *If a linear network code for the forward direction is valid, then it is also valid for the backward direction.*

Proof: A linear network code is valid, if the network channel matrix has a rank equal to n . If this is given, then the rank of the network channel matrix for the backward direction is also equal to n

$$\text{rank}(\mathbf{A}_b) = \text{rank}(\mathbf{A}^T) = \text{rank}(\mathbf{A}) = n. \quad (15)$$

Thus, in a bidirectional NC scenario it is sufficient to design a linear network code for one direction, e.g., with the aid of the *linear information flow (LIF) algorithm* [10]. This code can then be used also for the backward direction if the operations at the intermediate nodes are reversed according to Fig. 5.

V. CONCLUSION

In this work, we have classified NC variants, and have shown that all variants can be traced back to the most basic one—NC Variant I. We have studied layered networks, and the application of LNC to such networks. Moreover, a technique called layering has been proposed, which allows us to introduce a layered structure into arbitrary, non-layered networks. With the aid of the layered Variant I representation of communication networks we were able to state an algebraic expression of the mincut, and to derive the forward-backward duality for LNC, which can be seen as an analogon to the famous uplink-downlink duality for MIMO channels [7]. Furthermore, we already exploited the advantages of the layered Variant I representation of a communication network in the context of random linear network coding in [6].

REFERENCES

- [1] R. Ahlswede, N. Cai, S.-Y. Li, R.W. Yeung. “Network Information Flow,” *IEEE Tr. Inf. Theory*, pp. 1204–1216, July 2000.
- [2] S.-Y. Li, R. W. Yeung, N. Cai. “Linear Network Coding,” *IEEE Tr. Inf. Theory*, pp. 371–381, Feb. 2003.
- [3] T. Ho, M. Médard, R. Koetter, D.R. Karger, M. Effros, J. Shi, B. Leong. “A Random Linear Network Coding Approach to Multicast,” *IEEE Tr. Inf. Theory*, pp. 4413–4430, Oct. 2006.
- [4] D. Silva, F.R. Kschischang, R. Kötter. “Communication Over Finite-Field Matrix Channels,” *IEEE Tr. Inf. Theory*, pp. 1296–1305, Mar. 2010.
- [5] R. Kötter, M. Médard. An Algebraic Approach to Network Coding. *IEEE/ACM Tr. Networking*, Oct. 2003.
- [6] B. Schotsch, M. Cyran, J.B. Huber, R.F.H. Fischer, P. Vary. An Upper Bound on the Outage Probability of Random Linear Network Codes with Known Incidence Matrices. In Proc. *10. Int. ITG Conf. on Systems, Communications, and Coding (SCC)*, Feb. 2015.
- [7] M. Schubert, H. Boche. A Unifying Theory for Uplink and Downlink Multi-User Beamforming. In Proc. *IEEE Int. Zürich Seminar (IZS 2002)*, pp. 27/1–27/6, Feb. 2002.
- [8] C. Fragouli, E. Soljanin. Network Coding Fundamentals. *Foundations and Trends in Networking*, pp. 1–133, 2007.
- [9] R.F.H. Fischer. *Precoding and Signal Shaping for Digital Transmission*. New York: Wiley, 2002.
- [10] S. Jaggy, P. Sanders, P.A. Chou, M. Effros, S. Egner, K. Jain, L.M.G.M. Tolhuizen. Polynomial Time Algorithms for Multicast Network Code Construction. *IEEE Tr. Inf. Theory*, pp. 1973–1982, June 2005.