

The solvability of consensus in iterated models extended with safe-consensus *

Rodolfo Conde

Instituto Tecnológico Autónomo de México
Rio Hondo #1 Col. Progreso Tizapán, CDMX 01080, México
rodolfo.conde@itam.mx

Sergio Rajsbaum

Instituto de Matemáticas, Universidad Nacional Autónoma de México
Ciudad Universitaria, CDMX 04510, México
rajsbaum@im.unam.mx

July 2022

Abstract

The safe-consensus task was introduced by Afek, Gafni and Lieber (DISC' 09) as a weakening of the classic consensus. When there is concurrency, the consensus output can be arbitrary, not even the input of any process. They showed that safe-consensus is equivalent to consensus, in a wait-free system. We study the solvability of consensus in three shared memory iterated models extended with the power of safe-consensus black boxes. In the first iterated model, for the i -th iteration, the processes write to memory, then they snapshot it and finally they invoke safe-consensus boxes. We prove that in this model, consensus cannot be implemented. In a second iterated model, processes first invoke safe-consensus, then they write to memory and finally they snapshot it. We show that this model is equivalent to the previous model and thus consensus cannot be implemented. In the last iterated model, processes write to the memory, invoke safe-consensus boxes and finally they snapshot the memory. We show that in this model, any wait-free implementation of consensus requires $\binom{n}{2}$ safe-consensus black-boxes and this bound is tight.

Keywords: Consensus, safe-consensus, coalition, Johnson graph, connectivity, distributed algorithms, lower bounds, wait-free computing, iterated models.

*A Preliminary version of these results appeared in SIROCCO 2014.

1 Introduction

The ability to agree on a common decision is key to distributed computing. The most widely studied agreement abstraction is *consensus*. In the consensus task each process proposes a value, and all correct processes have to decide the same value. In addition, *validity* requires that the decided value is a proposed value.

Herlihy’s seminal paper [1] examined the power of different synchronization primitives for *wait-free computation*, e.g., when computation completes in a finite number of steps by a process, regardless of how fast or slow other processes run, and even if some of them halt permanently. He showed that consensus is a universal primitive, in the sense that a solution to consensus (with read/write registers) can be used to implement any synchronization primitive in a wait-free manner. Also, consensus cannot be wait-free implemented from read/write registers alone [2, 3]; indeed, all modern shared-memory multiprocessors provide some form of universal primitive.

Afek, Gafni and Lieber [4] introduced *safe-consensus*, which seemed to be a synchronization primitive much weaker than consensus. The validity requirement becomes: if the first process to invoke the task returns before any other process invokes it, then it outputs its input; otherwise, when there is concurrency, the consensus output can be arbitrary, not even the input of any process. In any case, all processes must agree on the same output value. Trivially, consensus implements safe-consensus. Surprisingly, they proved that the converse is also true, by presenting a wait-free implementation of consensus using safe-consensus black-boxes and read/write registers. Why is it then, that safe-consensus seems a much weaker synchronization primitive?

Our Results. We show that while consensus and safe-consensus are wait-free equivalent, any wait-free implementation of consensus for n processes in an iterated model (with the appropriate order of snapshot and safe-consensus operations) requires $\binom{n}{2}$ safe-consensus black-boxes, and this bound is tight.

Our main result is the lower bound. It uses connectivity arguments based on subgraphs of *Johnson graphs*, and an intricate combinatorial and bivalency argument, that yields a detailed bound on how many safe-consensus objects of each type (i.e., which processes and how many processes invoke a safe-consensus object) are used by the implementation protocol. For the upper bound, we present a simple protocol, based on the new *g-coalitions-consensus* task, which may be of independent interest¹.

We develop our results in an iterated model of computation [6], where the processes repeatedly: write their information to a (fresh) shared array, invoke (fresh) safe-consensus boxes and snapshot the contents of the shared array.

Also, we study the solvability of consensus in two alternate iterated models extended with safe-consensus. In the first model, the processes write to memory, then they snapshot it and finally they invoke safe-consensus boxes. We prove that in this model, consensus cannot be implemented from safe-consensus. In the second model, processes first invoke safe-consensus, then they write to shared memory and finally they snapshot the contents of the memory. We show that this model is equivalent to the previous model and thus consensus cannot be solved in this model.

Related Work. Distributed computing theory has been concerned from early on with understanding the relative power of synchronization primitives. The wait-free context is the basis to study other failure models e.g. [7], and there is a characterization of the wait-free, read/write solvable tasks [8]. For instance, the weakening of consensus, *set agreement*, where n processes may agree on at most $n - 1$ different input values, is still not wait-free solvable [9, 8, 10] with read/write registers only. The *renaming* task where n processes have to agree on at most $2n - 1$ names has also been studied in detail e.g. [11, 12, 13, 14, 15].

¹These results appeared for the first time in the Proceedings of the 21st International Colloquium on Structural Information and Communication Complexity [5].

Iterated models e.g. [6, 16, 17, 18, 19, 20] facilitate impossibility results, and (although more restrictive) facilitate the analysis of protocols [21]. We follow in this paper the approach of [22] that used an iterated model to prove the separation result that set agreement can implement renaming but not vice-versa, and expect our result can be extended to a general model using simulations, as was done in [23] for that separation result. For an overview of the use of topology to study computability, including the use of iterated models and simulations see [24].

Afek, Gafni and Lieber [4] presented a wait-free protocol that implements consensus using $\binom{n}{2}$ safe-consensus black-boxes (and read/write registers). Since our implementation uses the iterated form of shared-memory, it is easier to prove correct. Safe-consensus was used in [4] to show that the g -tight-group-renaming task² [25] is as powerful as g -consensus.

The idea of the classical consensus impossibility result [2, 3] is (roughly speaking) that the executions of a protocol in such a system can be represented by a graph which is always connected. The connectivity invariance has been proved in many papers using the critical state argument introduced in [2], or sometimes using a layered analysis as in [26]. Connectivity can be used also to prove time lower bounds e.g. [26, 27, 28]. We extend here the layered analysis to prove the lower bound result on the number of safe-consensus objects needed to implement consensus. Also, our results show that when the basic shared memory iterated model is used with objects stronger than read/write memory, care has to be taken in the way they are added to the model, as the resulting power of the model to solve tasks can vary.

In a previous work [29] we had already studied an iterated model extended with the power of safe-consensus. However, that model had the restriction that in each iteration, all processes invoke the same safe-consensus object. We showed that set agreement can be implemented, but not consensus. The impossibility proof uses much simpler connectivity arguments than those of this paper.

Organization. The paper is organized as follows. Section 2 describes the basic concepts and previous results of the models of computation. This section can be skipped by readers familiar with standard distributed computing notions. Section 3 defines the three iterated models of computation that we investigate and also we present the main results for each model. Section 4 is dedicated to our first iterated model with safe-consensus. In this model, the processes first write to memory, then they snapshot the contents of the memory and after that, they invoke safe-consensus objects. We prove that in this model, consensus cannot be implemented. In Section 4.2, we develop our second iterated model extended with safe-consensus. In this model, the processes first invoke safe-consensus objects, then they write to the memory and finally, they snapshot the shared memory. We prove that this model is equivalent to the previous model (for task solvability), thus the consensus task cannot be implemented in this model. Section 5 is devoted to develop all the results obtained for our last iterated model, in it the processes write to memory, invoke the safe-consensus objects and then they snapshot the shared memory. For this model, our results are the following:

- We construct a protocol that solves n -process consensus using $\binom{n}{2}$ safe-consensus boxes (Section 5.2). We give our consensus protocol using the new 2coalitions-consensus task, which is described in full detail in Section 5.1.
- We describe and prove the main result for this iterated model, which is also the main result of this paper, it is a lower bound on the number of safe-consensus objects needed to solve consensus in this iterated model (Section 5.3).

²In a tight group renaming task with group size g , n processes with ids from a large domain $\{1, 2, \dots, N\}$ are partitioned into m groups with ids from a large domain $\{1, 2, \dots, M\}$, with at most g processes per group. A tight group renaming task renames groups from the domain $1 \dots M$ to $1 \dots l$ for $l \ll M$, where all processors with the same initial group ID are renamed to the same new group ID, and no two different initial group ids are renamed to the same new group ID.

In Section 6 we give our final conclusions and some open problems.

2 Basic definitions

In this section, we introduce the model of computation and present many basic concepts used in this paper. We follow the usual definitions and extend some concepts from [30, 31].

2.1 Distributed systems

Our formal model is an extension of the standard iterated version [16] of the usual read/write shared memory model e.g. [31]. A *process* is a deterministic state machine, which has a (possible infinite) set of *local states*, including a subset called the *initial states* and a subset called the *output states*.

A *shared object* O has a domain D of input values, and a domain D' of output values. O provides a unique operation, $O.exec(d)$, that receives an input value $d \in D$ and returns an output value $d' \in D'$.

A one-shot snapshot object A is a shared memory array $A[1, \dots, n]$ with one entry per process. That array is initialized to $[\perp, \dots, \perp]$, where \perp is a default value that cannot be written by a process. The snapshot object A provides two atomic operations that can be used by a process at most once:

- $A.update(v)$: when called by process p_j , it writes the value v to the register $A[j]$.
- $A.scan()$: returns a copy of the whole shared memory array A .

It is also customary to make no assumptions about the size of the registers of the shared memory, and therefore we may assume that each process p_i can write its entire local state in a single register. Notice that the snapshot operation can be implemented in read/write shared memory, according to [32, 33].

A *system* consists of the following data:

- A set of $n \geq 1$ processes $\Pi = \{p_1, \dots, p_n\}$;
- a shared memory $SM[i]$ ($i \geq 0$) structured as an infinite sequence of one-snapshot objects;
- an infinite sequence $S[j]$ ($j \geq 0$) of shared objects.

A *global state* of a system is a vector P of the form

$$P = \langle s_1, \dots, s_n; SM \rangle,$$

where s_i is the local state of process $p_i \in \Pi$ and SM is the shared memory of the system. An *initial state* is a state in which every local state is an initial local state and all registers in the shared memory are set to \perp . A *decision state* is a state in which all local states are output states. When referring to a global state P , we usually omit the word global and simply refer to P as a state.

2.2 Events and round schedules

An *event* in the system is performed by a single process $p_i \in \Pi$, which applies only one of the following actions: a write (update) operation, denoted by W or a read (scan) operation, denoted by R , on the shared memory or an invocation to a shared object (S). Any of these operations may be preceded/followed by some local computation, formally a change of the process to its next local state. We will need to consider events

performed *concurrently* by the processes. If E is any event and $p_{i_1}, \dots, p_{i_k} \in \Pi$ are processes, then we denote the fact that p_{i_1}, \dots, p_{i_k} execute concurrently the event E by $E(X)$, where $X = \{i_1, \dots, i_k\}$.

We fix once and for all some notation. Let $\bar{n} = \{1, \dots, n\}$, when convenient, we will denote $E(X)$ by $E(i_1, \dots, i_k)$ and if $i \in \bar{n}$ is a process id, then $E(\bar{n} - \{i\})$ is written simply as $E(\bar{n} - i)$.

A *round schedule* π is a finite sequence of events of the form

$$\pi: E_1(X_1), \dots, E_r(X_r),$$

that encodes the way in which the processes with ids in the set $\bigcup_{j=1}^r X_j$ perform the events E_1, \dots, E_r . For example, the round schedule given by

$$W(1,3), R(1,3), W(2), R(2), S(1,2,3)$$

means that processes p_1, p_3 perform the write and read events concurrently; after that, p_2 executes solo its read and write events and finally all three processes invoke the shared objects concurrently. Similarly, the round schedule $W(1,2,3), R(1,2,3), S(1,2,3)$ says that p_1, p_2 and p_3 execute concurrently the write and read events in the shared memory and then they invoke the shared objects concurrently.

2.3 Protocols and executions

The state machine of each process $p_i \in \Pi$ is called a *local protocol* \mathcal{A}_i , that determines the steps taken by p_i . We assume that all local protocols are identical; i.e. Processes have the same state machine. A *protocol* is a collection \mathcal{A} of local protocols $\mathcal{A}_1, \dots, \mathcal{A}_n$.

For the sake of simplicity, we will give protocols specifications using pseudocode and we establish the following conventions: A lowercase variable denotes a local variable, with a subindex that indicates to which process it belongs; the shared memory (which is visible to all processes) is denoted with uppercase letters. Intuitively, the local state s_i of process p_i is composed of the contents of all the local variables of p_i . Also, we identify two special components of each process' states: an input and an output. It is assumed that initial states differ only in the value of the input component; moreover, the input component never changes. The protocol cannot overwrite the output, it is initially \perp ; once a non- \perp value is written to the output component of the state, it never changes; when this occurs, we say that the process *decides*. The output states are those with non- \perp output values.

Let \mathcal{A} be a protocol. An *execution* of \mathcal{A} is a finite or infinite alternating sequence of states and round schedules

$$S_0, \pi_1, \dots, S_k, \pi_{k+1}, \dots,$$

where S_0 is an initial state and for each $k \geq 1$, S_k is the resulting state of applying the sequence of events performed by the processes in the way described by the round schedule π_k . An *r-round partial execution* of \mathcal{A} is a finite execution of \mathcal{A} of the form $S_0, \pi_1, \dots, S_{r-1}, \pi_r, S_r$.

If P is a state, P is said to be *reachable in* \mathcal{A} if there exists an r -round partial execution of \mathcal{A} ($r \geq 0$) that ends in the state P and when there is no confusion about which protocol we refer to, we just say that P is reachable.

Given the protocol \mathcal{A} and two states S, R , we say that R is a *successor* of S in \mathcal{A} , if there exists an execution α of \mathcal{A} such that

$$\alpha = S_0, \pi_1, \dots, S_r = S, \pi_{r+1}, \dots, \pi_{r+k}, S_{r+k} = R, \dots,$$

i.e., starting from S , we can run the protocol \mathcal{A} k rounds (for some $k \geq 0$) such that the system enters state R . If π is any round schedule and S is a state, the successor of S in \mathcal{A} obtained by running the protocol (starting in the state S) one round with the round schedule π is denoted by $S \cdot \pi$.

2.4 Decision tasks

In distributed computing, a *decision task* is a problem that must be solved in a distributed system. Each process starts with a private input value, communicates with the others, and halts with a private output value. Formally, a *decision task* Δ is a relation that has a domain \mathcal{I} of input values and a domain \mathcal{O} of output values; Δ specifies for each assignment of the inputs to processes on which outputs processes can decide. A *bounded* decision task is a task whose number of input values is finite.

We also refer to decision task simply as tasks. Examples of tasks includes *consensus* [2], *renaming* [25, 33] and the *set agreement* task [34].

A protocol \mathcal{A} *solves* a decision task Δ if any finite execution α of \mathcal{A} can be extended to an execution α' in which all processes decide on values which are allowable (according to Δ) for the inputs in α . Because the outputs cannot be overwritten, if a process has decided on a value in α , it must have the same output in α' . This means that outputs already written by the processes can be completed to outputs for all processes that are permissible for the inputs in α .

A protocol \mathcal{A} is *wait-free* if in any execution of \mathcal{A} , a process either has a finite number of events or decides. This implies that if a process has an infinite number of events, it must decide after a finite number of events. Roughly speaking, \mathcal{A} is wait-free if any process that continues to run will halt with an output value in a fixed number of steps, regardless of delays or failures by other processes. However, in our formal model, we do not require the processes to halt; they solve the decision task and decide by writing to the output component; processes can continue to participate. We typically consider the behaviour of a process until it decides, and therefore, the above distinction does not matter.

The study of wait-free shared memory protocols has been fundamental in distributed computing, some of the most powerful results have been constructed on top of wait-free protocols [9, 8, 6, 10]. Also, other variants of distributed systems can be reduced to the wait-free case [7, 9, 35].

Definition of consensus and safe-consensus tasks.

The tasks of interest in this paper are the *consensus* and *safe-consensus* [4] tasks.

Consensus Every process starts with some initial input value taken from a set I and must output a value such that:

- Termination: Each process must eventually output some value.
- Agreement: All processes output the same value.
- Validity: If some process outputs v , then v is the initial input of some process.

Safe-consensus Every process starts with some initial input value taken from a set I and must output a value such that Termination and Agreement are satisfied, and:

- Safe-Validity: If a process p_i starts executing the task and outputs before any other process starts executing the task, then its decision is its own proposed input value. Otherwise, if two or more processes access the safe-consensus task concurrently, then any decision value is valid.

The safe-consensus task was proposed first in [4] as a result of weakening the validity condition of consensus.

3 Iterated models extended with safe-consensus and results

Intuitively, a model of distributed computing describes a set of protocols that share some common properties and restrictions in the way the processes can access the shared objects and these conditions affect the way in which the protocols can be specified. In this paper, we are interested in protocols which can be written in a simple and structured way, such that the behaviour of the system in the i th-iteration, can be described by using the behaviour of the $(i - 1)$ th-iteration, in an inductive way.

In this section, we introduce an extension of the basic iterated model of [16], adding the power of safe-consensus shared objects. We also present all the results of this paper.

3.1 The iterated model with shared objects

In the iterated model extended with shared objects, the processes can use two kinds of communication media. The first is the shared memory SM structured as an infinite array of snapshot objects; the second medium is the infinite array S of shared objects (SM and S are described in Section 2.1). The processes communicate between them through the snapshot objects and the shared objects of S , in an asynchronous and round-based pattern. In all the iterated models that we investigate, we make the assumption that the shared memory is composed of *one-shot snapshot objects* and the array S contains *one-shot shared objects*. Specifically, we assume that:

- The operations update and scan of the snapshot objects in SM can be used by a process at most once.
- The *exec* operation of each shared object in S can be used at most once by each process that invokes it.

When we want to add the power of shared objects to the standard iterated model [16], we must consider two important questions. The first question is: In which order should we place the three basic operations (write, read and invoke a shared object)? We have three possibilities:

- Write, read from the shared memory and invoke a shared object;
- invoke a shared object, write and read the shared memory;
- write to memory, invoke a shared object and read the contents of the shared memory.

The second question, which is very closely related to the previous one is: Does the order of the main operations affect the computational power of the new model (for task solvability)? In this paper, we address these two questions and show the differences of the models of distributed computing that we obtain when the shared objects invoked by the processes are safe-consensus objects.

A *safe-consensus object* is a shared object that can be invoked by any number of processes. The object receives an input value from each process that invokes it, and returns to all the processes an output value that satisfies the Agreement and Validity condition of the safe-consensus task. In other words, a safe-consensus object is like a “black box” that the processes can use to solve instances of the safe-consensus task. The method of using distributed tasks as black boxes inside protocols is a standard way to study the relative computational power of distributed tasks (i.e. if one task is weaker than another, see [4, 22, 36]). Notice that safe-consensus shared objects combined with shared memory registers, can implement consensus [4].

From now on, we work exclusively in iterated models, where the shared objects invoked by the processes are safe-consensus objects.

3.2 The WRO iterated model

We now define the first iterated model that we investigate; in it, processes write to shared memory, then they snapshot it and finally they invoke the safe-consensus objects. We say that a protocol is in the *WRO (Write, Read and invoke Object) iterated model* if it can be written in the form given in Figure 1.

```

(1) init  $r \leftarrow 0; sm \leftarrow input; dec \leftarrow \perp; val \leftarrow \perp;$ 
(2) loop forever
(3)    $r \leftarrow r + 1;$ 
(4)    $SM[r].update(sm, val);$ 
(5)    $sm \leftarrow SM[r].scan();$ 
(6)    $val \leftarrow S[h(\langle r, id, sm, val \rangle)].exec(v);$ 
(7)   if ( $dec = \perp$ ) then
(8)      $dec \leftarrow \delta(sm, val);$ 
(9)   end if
(10) end loop
```

Figure 1: The WRO iterated model

An explanation of the pseudocode in Figure 1 follows. All the variables $r, sm, val, input$ and dec are local to process p_i and only when we analyse a protocol, we add a subindex i to a variable to specify it is local to p_i . The symbol “ id ” contains the id of the executing process. Initially, r is zero and sm is assigned the contents of the read-only variable $input$, which contains the input value for process p_i ; all other variables are initialized to \perp . In each round, p_i increments by one the loop counter r , accesses the current shared memory array $SM[r]$, writing all the information it has stored in sm and val (full information) and taking a snapshot of the shared memory array and after these operations, p_i decides which shared object it is going to invoke by executing a deterministic function h that returns an index l , which p_i uses to invoke the shared object $S[l]$ with some value v . Finally, p_i checks if dec is equal to \perp , if so, it executes a deterministic function δ to determine if it may *decide* a valid output value or \perp . Notice that in each round of a protocol, each process invokes at most one safe-consensus object of the array S .

In Section 4, we argue that the consensus task cannot be implemented in the WRO iterated model using safe-consensus objects (Theorem 4.4), this is the main result for this iterated model.

3.3 The OWR iterated model

The second iterated model that we study is the *OWR (invoke Object, Write and Read) iterated model*. In this model, processes first invoke safe-consensus shared objects and then they write and snapshot the shared memory. We say that a protocol \mathcal{A} is in the OWR iterated model if \mathcal{A} can be written in the form specified in Figure 2.

This pseudocode is explained in a similar way to that used for the code in Figure 1, the only thing that changes is the place where we put the invocations to the safe-consensus shared objects, before the execution of the snapshot operations.

In Section 4.2, we argue that for task solvability, there is no real difference between the WRO and the OWR iterated models. Any protocol in the WRO iterated model can be simulated by a protocol in the OWR iterated model and the converse is also true, this is stated formally in Theorem 4.8. Combining this result with Theorem 4.4, we can conclude that it is impossible to solve consensus in the OWR iterated model (Corollary 4.9).

```

(1) init  $r \leftarrow 0; sm \leftarrow input; dec \leftarrow \perp; val \leftarrow \perp;$ 
(2) loop forever
(3)    $r \leftarrow r + 1;$ 
(4)    $val \leftarrow S[h(\langle r, id, sm, val \rangle)].exec(v);$ 
(5)    $SM[r].update(sm, val);$ 
(6)    $sm \leftarrow SM[r].scan();$ 
(7)   if ( $dec = \perp$ ) then
(8)      $dec \leftarrow \delta(sm, val);$ 
(9)   end if
(10) end loop

```

Figure 2: The OWR iterated model

3.4 The WOR iterated model

The last iterated model that we introduce is constructed by placing the safe-consensus objects between the update and snapshot operations. A protocol \mathcal{A} is in the *WOR* (*Write, invoke Object and Read*) iterated model if it can be written as specified in Figure 3.

```

(1) init  $r \leftarrow 0; sm \leftarrow input; dec \leftarrow \perp; val \leftarrow \perp;$ 
(2) loop forever
(3)    $r \leftarrow r + 1;$ 
(4)    $SM[r].update(sm, val);$ 
(5)    $val \leftarrow S[h(\langle r, id, sm, val \rangle)].exec(v);$ 
(6)    $sm \leftarrow SM[r].scan();$ 
(7)   if ( $dec = \perp$ ) then
(8)      $dec \leftarrow \delta(sm, val);$ 
(9)   end if
(10) end loop

```

Figure 3: The WOR iterated model

It turns out that the WOR iterated model is quite different from the two previous iterated models. This is true because of the following facts:

- The consensus task for n processes can be solved in the WOR iterated model using only $\binom{n}{2}$ safe-consensus black boxes (Theorem 5.6).
- Any protocol in the WOR iterated model which implements consensus using safe-consensus objects must use at least $\binom{n}{2}$ safe-consensus objects.

The second fact, which is a consequence of Theorem 5.7, is the main result of this paper. It describes a matching lower bound on the number of safe-consensus objects needed to solve consensus by any protocol in the WOR iterated model which implements consensus. In Section 5, we give the detailed description of the WOR iterated protocol which implements consensus using safe-consensus objects, we prove its correctness and finally, we give the proof of the lower bound on the number of safe-consensus objects needed to solve

consensus in the WOR iterated model. Our lower bound proof is based in the fact that, if for a protocol \mathcal{A} there exists $m_0 \in \{2, \dots, n\}$ such that there are not enough groups (of size m_0) of processes that can invoke safe-consensus shared objects, then \mathcal{A} will fail to solve consensus. Specifically, \mathcal{A} cannot solve consensus if the total number of groups of size m_0 is no more than $n - m_0$. See Theorem 5.7 in Section 5.3 for the full details.

3.5 Shared objects represented as combinatorial sets

We now introduce some combinatorial definitions which will help us represent shared objects and the specific way in which the processes can invoke these shared objects. These definitions are useful in Sections 4 and 5.

For any $n \geq 1$ and $m \in \bar{n}$, let $V_{n,m} = \{c \subseteq \bar{n} \mid |c| = m\}$. Given a protocol \mathcal{A} , we define for each $m \leq n$ the set $\Gamma_{\mathcal{A}}(n, m) \subseteq V_{n,m}$ as follows: $b = \{i_1, \dots, i_m\} \in \Gamma_{\mathcal{A}}(n, m)$ if and only if in some execution of \mathcal{A} , only the processes p_{i_1}, \dots, p_{i_m} invoke a safe-consensus object of the array S (see Figures 1, 2 and 3). Roughly speaking, each $c \in \Gamma_{\mathcal{A}}(n, m)$ represents a set of processes which together can invoke safe-consensus shared objects in \mathcal{A} .

For example, if $m = 3$ and $c = \{i, j, k\} \in \Gamma_{\mathcal{A}}(n, 3)$, then in at least one round of \mathcal{A} , processes p_i, p_j and p_k invoke a safe-consensus object and if in another round or perhaps another execution of \mathcal{A} , these processes invoke another safe-consensus object in the same way, then these two invocations are represented by the same set $c \in \Gamma_{\mathcal{A}}(n, 3)$, that is, shared objects invoked by the same processes are considered as the same element of $\Gamma_{\mathcal{A}}(n, 3)$ (repetitions do not count). On the other hand, if $d = \{i, j, l\} \notin \Gamma_{\mathcal{A}}(n, 3)$, then there does not exist an execution of \mathcal{A} in which only the three processes p_i, p_j and p_l invoke a safe-consensus shared object.

A set $b \in \Gamma_{\mathcal{A}}(n, m)$ is called a *m-box* or simply a *box*. An element $d \in \Gamma_{\mathcal{A}}(n, 1)$ is called a *trivial box*, it represents a safe-consensus object invoked only by one process, we consider such objects as useless, because they do not give any additional information to the process. We model a process that does not invoke a safe-consensus object as a process that invokes a safe-consensus object and no other process invokes that object, i.e., this safe-consensus object is represented by a trivial box. A process p_i *participates* in the box b if $i \in b$. Let the set $\Gamma_{\mathcal{A}}(n)$ and the quantities $v_{\mathcal{A}}(n, m)$ and $v_{\mathcal{A}}(n)$ be defined as follows:

$$\Gamma_{\mathcal{A}}(n) = \bigcup_{m=2}^n \Gamma_{\mathcal{A}}(n, m);$$

$$v_{\mathcal{A}}(n, m) = |\Gamma_{\mathcal{A}}(n, m)|;$$

$$v_{\mathcal{A}}(n) = \sum_{m=2}^n v_{\mathcal{A}}(n, m).$$

From now on, for all our protocols, we consider global states only at the end of some iteration. Suppose that P is a reachable state in the protocol \mathcal{A} . The set of shared objects o_1, \dots, o_q invoked by the processes to enter state P is represented by a set of boxes $\mathbf{Inv}(P) = \{b_1, \dots, b_q\}$ which is called the *global invocation specification* of P . We assume without loss of generality that in all rounds, each process invokes some shared object, that is, the set $\mathbf{Inv}(P)$ satisfies

$$\bigcup_{b \in \mathbf{Inv}(P)} b = \bar{n},$$

(a process that does not invoke a safe-consensus object can be seen as a process that invokes a safe-consensus object and no other process invokes that object). Notice that since each process invokes only one safe-consensus object in each round, $\mathbf{Inv}(P)$ is a *partition* of \bar{n} .

If $b = \{l_1, \dots, l_s\} \in \mathbf{Inv}(P)$ is a box representing a safe-consensus shared object invoked by the processes p_1, \dots, p_s , we define the *safe-consensus value of b in P* , denoted by $\text{scval}(b, P)$ as the unique output value of the safe-consensus shared object represented by b .

3.6 Additional definitions on global states

We now introduce the notions of connectivity and paths between global states. These are well known concepts [2, 8] and have become a fundamental tool to study distributed systems.

Paths of global states

Two states S, P are said to be *adjacent* if there exists a non-empty subset $X \subseteq \bar{n}$ such that all processes with ids in X have the same local state in both S and P . That is, for each $i \in X$, p_i cannot *distinguish* between S and P . We denote this by $S \overset{X}{\sim} P$. States S and P are *connected*, if we can find a sequence of states (called a *path*)

$$p: S = P_1 \sim \dots \sim P_r = P,$$

such that for all j with $1 \leq j \leq r-1$, P_j and P_{j+1} are adjacent.

Connectivity of global states are a key concept for many beautiful results in distributed systems, namely, impossibility proofs. The indistinguishability of states between processes is the building block to construct topological structures based on the executions of a given protocol and is fundamental in many papers [9, 29, 8, 3, 10]. In addition to the classic definitions of connectivity and paths, we also introduce the following concepts. Let $q: Q_1 \sim \dots \sim Q_l$ be a path of connected states, define the *set of states* $\text{States}(q)$; the *set of indistinguishability sets* $\text{iSets}(q)$; and the *degree of indistinguishability* $\text{deg } q$, of q as follows:

$$\text{States}(q) = \{Q_1, \dots, Q_l\};$$

$$\text{iSets}(q) = \{X \subseteq \bar{n} \mid (\exists Q_i, Q_j \in \text{States}(q))(Q_i \overset{X}{\sim} Q_j)\};$$

$$\text{deg } q = \min\{|X| \mid X \in \text{iSets}(q)\}.$$

The degree of indistinguishability of the path q guarantees that we can find for any pair of states $Q_i, Q_j \in \text{States}(q)$ with $Q_i \sim Q_j$, a set of processes $P \subset \Pi$ that cannot distinguish between Q_i and Q_j such that $|P| \geq \text{deg } q$. The degree of indistinguishability of a path is usually of non-importance in the standard and well known bivalency proofs of the impossibility of consensus in various systems [2, 3], but in the impossibility proof of Section 4 and also the lower bound proof of Section 5, measuring the degree of indistinguishability will be a recurring action in all the proofs.

A path p of connected states of \mathcal{A} is said to be *C-regular* if and only if $\mathbf{Inv}(S) = \mathbf{Inv}(Q)$ for all $S, Q \in \text{States}(p)$, that is, p is C-regular when all the states in the set $\text{States}(p)$ have the same global invocation specification.

Lemma 3.1. *Let \mathcal{A} be an iterated protocol for n processes, $A \subseteq \bar{n}$ a non-empty set and S, Q two reachable states of \mathcal{A} in round r , such that for all $j \in A$, p_j cannot distinguish between S and Q . Then all processes with ids in A participate in the same boxes in S and Q .*

Sketch. Intuitively, for each $j \in A$, p_j has the same content in all its local variables, thus it inputs the same values for the function h that outputs the index of the shared object (box) p_j is going to invoke in S and Q respectively. Therefore h outputs the same index in both states, gather that, p_j invokes the same shared object in S and Q . \square

3.7 Consensus protocols

We need some extra definitions regarding consensus protocols: If v is a valid input value of consensus for processes and S is a state, we say that S is v -valent if in any possible execution starting from S , there exists a process that outputs v . S is *univalent* if in every execution starting from S , processes always output the same value. If S is not univalent, then S is *bivalent*³.

Lemma 3.2. *Any two initial states of a protocol for consensus are connected.*

Proof. Let S, P be two initial states. If S and P differ only in the initial value $input_i$ of a single process p_i , then S and P are adjacent (Only p_i can distinguish between the two states, the rest of the processes have the same initial values). In the case S and P differ in more than one initial value, they can be connected by a sequence of initial states $S = S_1 \sim \dots \sim S_q = P$ such that S_j, S_{j+1} differ only in the initial value of some process (we obtain S_{j+1} from S_j by changing the input value of some process p_i , the result is a valid input of the consensus problem), hence they are adjacent. In summary, S and P are connected. \square

We need one last result about consensus protocols, we omit its easy proof.

Lemma 3.3. *Suppose that \mathcal{A} is a protocol that solves the consensus task and that I, J are connected initial states of \mathcal{A} , such that for all rounds $r \geq 1$, I_r, J_r are connected successor states of I and J respectively. Also, assume that I is a v -valent state. Then J is v -valent.*

Proof. Suppose that I is v -valent and J is v' -valent ($v \neq v'$). By hypothesis, for all rounds $r \geq 1$, I_r and J_r are connected successor states of I and J respectively. Thus, for any $r \geq 0$, we can find r -round partial executions

$$I = I_0, \pi_1, I_1, \dots, \pi_r, I_r \quad \text{and} \quad J = J_0, \pi'_1, J_1, \dots, \pi'_r, J_r,$$

such that I_r and J_r are connected states for all $r \geq 0$. Given that \mathcal{A} solves consensus, there must exist $k \geq 1$ such that I_u and J_u are decision states for all $u \geq k$. Let p_u be a path connecting I_u and J_u . For the rest of the proof, assume that $\text{States}(p_u) = \{I_u, J_u\}$ (i.e., $I_u \sim J_u$), as the general case will follow easily from this case and induction on $|\text{States}(p_u)|$.

Since I_u is a successor state of I , which is a v -valent state, all processes decide v in I_u ; similarly, as J_u is a successor state of J (a v' -valent state), processes decide v' in J_u . Let p be a process that cannot distinguish between I_u and J_u . Then the local state of p in I_u and J_u must be the same and this includes its output component. But this is a contradiction, because in I_u , p decides v while in J_u , p decides v' . We conclude that J must be v -valent, such as I . \square

4 Impossibility of consensus in the WRO and OWR iterated models

In this section, we prove that the consensus task cannot be implemented in the WRO iterated model with safe-consensus objects and we extend this result to the OWR iterated model, by showing that the WRO and OWR iterated models are equivalent models in their computational power to solve tasks. Given that there exists a protocol in the standard model that solves consensus with registers and safe-consensus objects [4], it is a consequence of the results presented in this section that the WRO and OWR iterated models are not equivalent to the standard model extended with safe-consensus objects.

³This definition of valency is based on [2].

4.1 The impossibility of consensus in the WRO iterated model

We give a negative result concerning protocols in the WRO iterated model. Although there exist wait-free shared memory protocols that can solve consensus using safe-consensus objects [4], in this paper we show that there is no protocol in the WRO iterated model that solves consensus using safe-consensus objects. We first introduce some extra definitions and results that we will be using and after that, we prove that there is no protocol in the WRO iterated model which can solve the consensus task. For simplicity, we will refer to a protocol in the WRO iterated model simply as a WRO protocol.

Lemma 4.1. *Let \mathcal{A} be a WRO protocol for n processes, $A_i = \bar{n} - i$ for some $i \in \bar{n}$. Assume there exist S, Q two reachable states of \mathcal{A} in round r , such that for all $j \in A_i$, p_j does not distinguish between S and Q . Then $\mathbf{Inv}(S) = \mathbf{Inv}(Q)$.*

Proof. Let \mathcal{A} be a WRO protocol, $A_i = \bar{n} - i$ and S, Q such that every process p_j with $j \in A_i$ cannot distinguish between S and Q . By Lemma 3.1, if $b \in \mathbf{Inv}(S)$ is a box such that $i \notin b$, then $b \in \mathbf{Inv}(Q)$. For the box $c \in \mathbf{Inv}(S)$ that contains the id i , we argue by cases:

Case I. $|c| = 1$. All processes with ids in A_i participate in the same boxes in both states S and Q and p_i does not participate in those boxes, thus $c = \{i\} \in \mathbf{Inv}(Q)$.

Case II. $|c| > 1$. There exists a process p_j with $j \in c$ and $j \neq i$. Then $j \in A_i$, so that by Lemma 3.1, $c \in \mathbf{Inv}(Q)$.

We have prove that $\mathbf{Inv}(S) \subseteq \mathbf{Inv}(Q)$. To show that the other inclusion holds, the argument is symmetric. Therefore $\mathbf{Inv}(S) = \mathbf{Inv}(Q)$. \square

In order to prove the impossibility of consensus in the WRO iterated model (Theorem 4.4), we need various results that describe the structure of protocols in the WRO iterated model. These results tell us that for any given WRO protocol, the degree of indistinguishability of paths of connected states is high, even with the added power of safe-consensus objects, because we can make the safe-consensus values returned by the shared objects the same in all these reachable states, so that they cannot help the processes distinguish between these states. This is the main reason (of) why consensus cannot be implemented with safe-consensus in the WRO iterated model.

The following construction will be useful for the rest of this section. If $A_1, \dots, A_q \subset \bar{n}$ ($q \geq 1$) is a collection of disjoint subsets of \bar{n} , define the round schedule

$$\eta(A_1, \dots, A_q, Y)$$

for \mathcal{A} as:

$$W(A_1), R(A_1), W(A_2), R(A_2), \dots, W(A_q), R(A_q), W(Y), R(Y), S(\bar{n})$$

where $Y = \bar{n} - (\bigcup_{i=1}^q A_i)$. Sometimes, we omit the set Y and just write $\eta(A_1, \dots, A_q)$. The key point of the round schedule $\eta(A_1, \dots, A_q, Y)$ is that in a given one-round execution of a WRO protocol, it will allow us to choose the safe-consensus values of the safe-consensus shared objects invoked by at least two processes (using the Safe-Validity property of the safe-consensus task).

Our next Lemma is the first step to prove Theorem 4.4. Roughly speaking, it tells us that if a WRO protocol has entered any reachable state S , then we can find two one-round successor states of S , such that we can connect these states with a small path of very high indistinguishability degree. These two successor states of S are obtained when the processes execute the WRO protocol in such a way that only one process is

delayed in the update and snapshot operations, but all processes execute the safe-consensus shared objects concurrently in every state of the resulting path, thus we can keep the safe-consensus values of every safe-consensus shared object the same in every state.

Lemma 4.2. *Let $n \geq 2$, \mathcal{A} a WRO protocol and $i, j \in \bar{n}$. If S is a reachable state of \mathcal{A} in round $r \geq 0$ and the states $Q_i = S \cdot \eta(\bar{n} - i)$ and $Q_j = S \cdot \eta(\bar{n} - j)$ satisfy the conditions*

- A. $\mathbf{Inv}(Q_i) = \mathbf{Inv}(Q_j)$;
- B. $(\forall b \in \mathbf{Inv}(Q_i))(\text{scval}(b, Q_i) = \text{scval}(b, Q_j))$.

Then Q_i and Q_j are connected in round $r + 1$ of \mathcal{A} with a C-regular path q with $\deg q \geq n - 1$.

Proof. If $i = j$, the result is immediate. Suppose that $i \neq j$ and $\bar{n} - i = \{l_1, \dots, l_{n-1}\}$ with $l_{n-1} = j$. We show that Q_i and Q_j can be connected with a C-regular sequence with indistinguishability degree $n - 1$ by building three subsequences q_1, q_2 and q_3 .

We proceed to build the sequence q_1 . We claim that there exists a state Q of the form $Q = S \cdot \eta(l_1, \bar{n} - \{i, l_1\}, i)$ such that

- $\mathbf{Inv}(Q_i) = \mathbf{Inv}(Q)$;
- $\text{scval}(b, Q_i) = \text{scval}(b, Q)$ for all $b \in \mathbf{Inv}(Q)$.

The first property holds because in any state of the form $S \cdot \eta(l_1, \bar{n} - \{i, l_1\}, i)$, only process l_1 can distinguish between Q_i and Q , thus by Lemma 4.1 we obtain that $\mathbf{Inv}(Q_i) = \mathbf{Inv}(Q)$. Now, in both Q_i and Q , all processes execute the safe-consensus shared objects concurrently and we can use the Safe-Validity property of the safe-consensus task to find a state of \mathcal{A} in round $r + 1$ such that $Q = S \cdot \eta(l_1, \bar{n} - \{i, l_1\}, i)$ in which $\text{scval}(b, Q_i) = \text{scval}(b, Q)$ for each $b \in \mathbf{Inv}(Q) = \mathbf{Inv}(Q_i)$. This proves the second property. Therefore, we have that

$$Q_i = S \cdot \eta(\bar{n} - i, i) \stackrel{\bar{n}-l_1}{\sim} S \cdot \eta(l_1, \bar{n} - \{i, l_1\}, i) = Q$$

and this sequence is a C-regular path. Repeating the same argument, we can connect Q with a state of the form $P = S \cdot \eta(l_1, l_2, \bar{n} - \{i, l_1, l_2\}, i)$ and obtain the three state C-regular path $Q_i \stackrel{\bar{n}-l_1}{\sim} Q \stackrel{\bar{n}-l_2}{\sim} P$. Continuing in this way, we can show that the path q_1 is given by

$$S \cdot \eta(\bar{n} - i, i) \stackrel{\bar{n}-l_1}{\sim} S \cdot \eta(l_1, \bar{n} - \{i, l_1\}, i) \stackrel{\bar{n}-l_2}{\sim} \dots \stackrel{\bar{n}-l_{n-2}}{\sim} S \cdot \eta(l_1, \dots, l_{n-1}, i),$$

which is clearly a C-regular path by repeated use of the previous argument. In the same way, we construct the sequence q_2 as

$$S \cdot \eta(l_1, \dots, l_{n-1}, i) \stackrel{\bar{n}-l_{n-1}}{\sim} S \cdot \eta(l_1, \dots, \{l_{n-1}, i\}) \stackrel{\bar{n}-i}{\sim} S \cdot \eta(l_1, \dots, i, l_{n-1})$$

and finally, in a very similar way, we build q_3 as follows,

$$\begin{aligned} S \cdot \eta(l_1, \dots, i, l_{n-1}) &\stackrel{\bar{n}-l_{n-2}}{\sim} S \cdot \eta(l_1, \dots, \{l_{n-2}, i\}, l_{n-1}) \\ &\stackrel{\bar{n}-l_{n-3}}{\sim} \dots \stackrel{\bar{n}-l_2}{\sim} \\ &S \cdot \eta(l_1, \bar{n} - \{l_1, l_{n-1}\}, l_{n-1}) \stackrel{\bar{n}-l_1}{\sim} S \cdot \eta(\bar{n} - l_{n-1}, l_{n-1}). \end{aligned}$$

Both q_2 and q_3 are C-regular paths and for $k = 1, 2, 3$, $\deg q_k = n - 1$. Notice that the processes execute the safe-consensus objects in the same way in all the states of the previous sequences, and by construction, all the states have the same invocation specification. As $j = l_{n-1}$, $S \cdot \eta(\bar{n} - l_{n-1}, l_{n-1}) = S \cdot \eta(\bar{n} - j, j) = Q_j$, thus we can join q_1, q_2 and q_3 to obtain a C-regular path $q: Q_i \sim \dots \sim Q_j$ such that $\deg q = n - 1$. This finishes the proof. \square

Lemma 4.3 is the next step towards proving Theorem 4.4. Basically, it says that for any WRO protocol, if we already have a path of connected states with high indistinguishability degree for some round, then we can use this path to build a new sequence of connected states in the next round with a high degree of indistinguishability. Again, using the round schedules where the processes execute the safe-consensus shared objects concurrently, we can render useless the safe-consensus values, so that the number of processes that cannot distinguish between a pair of states of the path is as high as possible.

Lemma 4.3. *Let \mathcal{A} be a WRO protocol and S, P be two reachable states of some round $r \geq 0$ such that S and P are connected with a sequence s such that $\deg s \geq n - 1$; suppose also that the number of participating processes is $n \geq 2$. Then there exist successor states S', P' of S and P respectively, in round $r + 1$ of \mathcal{A} , such that S' and P' are connected with a C-regular path q with $\deg q \geq n - 1$.*

Proof. Suppose that S and P are connected with a sequence $s: S = S_1 \sim \dots \sim S_m = P$ such that for all j ($1 \leq j \leq m - 1$), $S_j \stackrel{X}{\sim} S_{j+1}$, where $|X| \geq n - 1$. Let p_1, \dots, p_n be the set of participating processes. We now construct a sequence of connected states

$$q: Q_1 \sim \dots \sim Q_s,$$

in such a way that each Q_i is a successor state to some state S_j and $\deg q \geq n - 1$. We use induction on m ; for the basis, consider the adjacent states S_1, S_2 and suppose that all processes with ids in the set X_1 ($|X_1| \geq n - 1$) cannot distinguish between S_1 and S_2 . By the Safe-Validity property of the safe-consensus task and Lemma 4.1, we can find states Q_1, Q_2 such that

- $Q_1 = S_1 \cdot \eta(X_1)$ and $Q_2 = S_2 \cdot \eta(X_1)$;
- Q_1 and Q_2 are indistinguishable for all processes with ids in X_1 ;
- $\mathbf{Inv}(Q_1) = \mathbf{Inv}(Q_2)$.

Combining these facts, we can see that the small sequence $Q_1 \stackrel{X_1}{\sim} Q_2$ is C-regular and has indistinguishability degree at least $n - 1$. Assume now that we have build the sequence

$$q': Q_1 \sim \dots \sim Q_{s'},$$

of connected successor states for $S_1 \sim \dots \sim S_q$ ($1 \leq q < m$) such that q' is C-regular, $\deg q' \geq n - 1$ and $Q_{s'} = S_q \cdot \eta(X)$ with $|X| \geq n - 1$. Let X_q with $|X_q| \geq n - 1$ be a set of processes' ids that cannot distinguish between S_q and S_{q+1} . To connect $Q_{s'}$ with a successor state for S_{q+1} , we first use Lemma 4.2 to connect $Q_{s'}$ and $Q = S_q \cdot \eta(X_q)$ by means of a C-regular sequence p such that $\deg p \geq n - 1$. Second, notice that we have the small C-regular path $s: Q \stackrel{X_q}{\sim} S_{q+1} \cdot \eta(X_q) = Q_{s'+1}$. In the end, we use q', p and s to get a C-regular sequence

$$q: Q_1 \sim \dots \sim Q_{s'+1},$$

which fulfils the inequality $\deg q \geq n - 1$. By induction, the result follows. \square

Using Lemmas 4.2 and 4.3 and previous results regarding bivalency arguments, we can finally prove the impossibility of consensus in the WRO iterated model.

Theorem 4.4. *There is no protocol for consensus in the WRO iterated model using safe-consensus objects.*

Proof. Suppose \mathcal{A} is a WRO protocol that solves consensus with safe-consensus objects and without loss, assume that 0,1 are two valid input values. Let O, U be the initial states in which all processes have as initial values only 0 and 1 respectively. By Lemma 3.2, O and U are connected and it is easy to see that the sequence joining O and U , build in the proof on Lemma 3.2 has degree of indistinguishability $n - 1$. So that applying an easy induction, we can use Lemma 4.3 to show that there exist connected successor states O_r, U_r of O and U respectively in each round $r \geq 1$ of the protocol \mathcal{A} . Clearly, O is a 0-valent state and by Lemma 3.3, U is 0-valent. But this is a contradiction, because U is a 1-valent state. Therefore no such protocol \mathcal{A} can exist. \square

At this moment we remark that the key fact that allows us to prove this impossibility of consensus in the WRO model, is that in all our proofs, we are able to “neutralize” the safe-consensus objects by making all processes invoke their respective shared objects concurrently, this is the entry point for the Safe-Validity property of consensus to allow us to find the states of the executing protocol with the same safe-consensus values, so that the processes can only distinguish different states by their local view of the shared memory. In contrast to the protocols in the WOR model, it is not possible to apply this technique and neutralize the safe-consensus objects, because the shared objects operations are located between the update and snapshot operations, so that when the processes take the snapshot, they have already invoked the safe-consensus shared objects.

4.2 The equivalence of the WRO and OWR iterated models

In this section, we prove Theorem 4.8, which tells us that the WRO and the OWR iterated models have the same computational power. We show that given any protocol in the WRO iterated model, there is an OWR protocol that can simulate its behaviour and the converse is also true. To check the meaning of some definition or previous result, the reader may consult Sections 2, 3.2 and 3.3. For the sake of simplicity, we will refer to a protocol in the OWR iterated model, simply as an OWR protocol.

Transforming a WRO protocol into an OWR protocol

The algorithm of Figure 4 is a generic OWR protocol to simulate protocols in the WRO iterated model. Suppose that \mathcal{A} is a WRO protocol that solves a task Δ and assume that $h_{\mathcal{A}}$ is the deterministic function to select safe-consensus objects in \mathcal{A} and $\delta_{\mathcal{A}}$ is the decision map used in the protocol \mathcal{A} . To obtain an OWR protocol \mathcal{B} that simulates the behaviour of \mathcal{A} , we use the generic protocol of Figure 4, replacing the functions h_{\perp} and δ_{\perp} with $h_{\mathcal{A}}$ and $\delta_{\mathcal{A}}$ respectively. If the processes execute \mathcal{B} with valid input values from Δ , then in the first round, the participating processes discard the output value of the safe-consensus object that they invoke, because the test at line (6) is successful and after that, each process goes on to execute the write-snapshot operations, with the same values that they would use to perform the same operations in round one of \mathcal{A} . Later, at lines (13)-(15), they do some local computing to try to decide an output value. It is clear from the code of the generic protocol that none of the executing processes will write a non- \perp value to the local variables dec , thus no process makes a decision in the first round and they finish the current round, only with two simulated operations from \mathcal{A} : write and snapshot. In the second round, the processes invoke one or more safe-consensus objects at line (5), accordingly to the return values of the function $h_{\mathcal{A}}$, which is invoked

with the values obtained from the snapshot operation of the previous round (from the round one write-read simulation of \mathcal{A}) and notice that instead of using the current value of the round counter r , the processes call $h_{\mathcal{A}}$ with the parameter $r - 1$. Since $r = 2$, the processes invoke $h_{\mathcal{A}}$ as if they were still executing the first round of the simulated protocol \mathcal{A} . Finally, after using the safe-consensus objects, processes do local computations in lines (8)-(10), using the decision map $\delta_{\mathcal{A}}$ to simulate the decision phase of \mathcal{A} , if for some process p_j , it is time to take a decision in \mathcal{A} , it stores the output value in the local variable dec'_j , which is used at the end of the round to write the output value in dec_j and then p_j has decided. If the map $\delta_{\mathcal{A}}$ returns \perp , then p_j goes on to do the next write-read operations (simulating the beginning of round two of \mathcal{A}) and proceeds to round three of \mathcal{B} . The described behaviour is going to repeat in all subsequent rounds.

Algorithm WRO-Simulation

```

(1) init  $r \leftarrow 0; sm, tmp \leftarrow input; dec, dec' \leftarrow \perp; val \leftarrow \perp;$ 
(2) loop forever
(3)    $r \leftarrow r + 1;$ 
(4)    $sm \leftarrow tmp;$ 
(5)    $val \leftarrow S[h_{\mathcal{A}}(r - 1, id, sm, val)].exec(v);$ 
(6)   if  $(r = 1)$  then
(7)      $val \leftarrow \perp;$            /* 1st round: ignore returned value */
(8)   else if  $(dec' = \perp)$  then
(9)      $dec' \leftarrow \delta_{\mathcal{A}}(sm, val);$  /* Decision of simulated protocol */
(10)  end if
(11)   $SM[r].update(sm, val);$ 
(12)   $tmp \leftarrow SM[r].scan();$ 
(13)  if  $(dec = \perp)$  then
(14)     $dec \leftarrow dec';$        /* Decide when simulated protocol decides */
(15)  end if
(16) end loop

```

Figure 4: General WRO-simulation protocol in the OWR iterated model

Correspondence between executions of the protocols

Let π be a round schedule. Denote by $\pi[W, R]$ the sequence of write and read events of π , these events appear in $\pi[W, R]$ just in the same order they are specified in π . The symbol $\pi[S]$ is defined for the event S in a similar way. For example, given the round schedule

$$\pi = W(1, 3), R(1, 3), W(2), R(2), S(1, 2, 3),$$

then $\pi[W, R] = W(1, 3), R(1, 3), W(2), R(2)$ and $\pi[S] = S(1, 2, 3)$. For another example, suppose that the round schedule π' is given by

$$\pi' = W(1, 2, 3), R(1, 2, 3), S(1), S(3), S(2).$$

In this case, we have that $\pi'[W, R] = W(1, 2, 3), R(1, 2, 3)$ and $\pi'[S] = S(1), S(3), S(2)$.

Let \mathcal{A} be a WRO protocol as given in Figure 1, $h_{\mathcal{A}}$ the deterministic function to select safe-consensus objects and $\delta_{\mathcal{A}}$ the decision map used in the protocol \mathcal{A} . An OWR protocol \mathcal{B} that simulates the behaviour of \mathcal{A} is obtained by using the generic protocol \mathcal{G} of Figure 4. To construct \mathcal{B} , we only replace the functions $h_{\mathcal{A}}$ and $\delta_{\mathcal{A}}$ of \mathcal{G} with $h_{\mathcal{A}}$ and $\delta_{\mathcal{A}}$ respectively.

In order to show that \mathcal{B} simulates \mathcal{A} , we first notice that there is a correspondence between executions of \mathcal{A} and \mathcal{B} . For, if α is an execution of \mathcal{A} such that

$$\alpha = S_0, \pi_1, S_1, \dots, \pi_k, S_k, \pi_{k+1}, \dots$$

Then there exists an execution $\alpha_{\mathcal{B}}$ of \mathcal{B}

$$\alpha_{\mathcal{B}} = S_0, \pi'_1, S'_1, \dots, \pi'_k, S'_k, \pi'_{k+1}, \dots,$$

such that

$$\pi'_l = \begin{cases} S(X_1) \dots, S(X_s), \pi_l [W, R] & \text{if } l = 1, \\ \pi_{l-1} [S], \pi_l [W, R] & \text{otherwise,} \end{cases}$$

where $\bigcup_{j=1}^s X_j = \bar{n}$ is an arbitrary partition of \bar{n} . Conversely, for any execution $\beta = R_0, \eta_1, R_1, \dots, \eta_k, R_k, \eta_{k+1}, \dots$ of the protocol \mathcal{B} , we can find an execution

$$\beta_{\mathcal{A}} = R_0, \eta'_1, R'_1, \dots, \eta'_k, R'_k, \eta_{k+1}, \dots$$

of \mathcal{A} such that

$$\eta'_l = \eta_l [W, R], \eta_{l+1} [S] \quad \text{for all } l \geq 1.$$

Lemma 4.5. *Suppose that β is an execution of the protocol \mathcal{B} and process p_i is executing the protocol (accordingly to β) in round $r > 0$ at line 11. Then the local variables sm_i, dec'_i and val_i of \mathcal{B} have the same values of the respectively local variables sm_i, dec_i and val_i of the protocol \mathcal{A} , when p_i finishes executing round $r - 1$ of \mathcal{A} , in the way specified by the execution $\beta_{\mathcal{A}}$.*

Proof. The proof is based on induction on the round number r , the base case and the inductive case are obtained by an easy analysis of the programs given in Figures 1 and 4. \square

The converse of the previous lemma is also true.

Lemma 4.6. *Suppose that α is an execution of the protocol \mathcal{A} and process p_i is executing the protocol (accordingly to α) in round $r > 0$ at line 4. Then the local variables sm_i, dec_i and val_i of \mathcal{A} have the same values of the respective local variables sm_i, dec'_i and val_i of the protocol \mathcal{B} , when p_i finishes executing round $r + 1$ of \mathcal{B} , in the way specified by the execution $\alpha_{\mathcal{B}}$.*

The final result that we need to prove that \mathcal{B} simulates \mathcal{A} for task solvability is an immediate consequence of Lemma 4.5.

Lemma 4.7. *Suppose that Δ is a decision task solved by the protocol \mathcal{A} and let $p_i \in \Pi$. Then p_i decides an output value v in round $r > 0$ of an execution α of \mathcal{A} if and only if p_i decides the output value v in round $r + 1$ of \mathcal{B} , in the execution $\alpha_{\mathcal{B}}$.*

This shows that the protocol \mathcal{B} simulates the behaviour of \mathcal{A} for task solvability and therefore proves the first part of Theorem 4.8.

```

Algorithm OWR-Simulation
(1) init  $r \leftarrow 0$ ;  $sm \leftarrow input$ ;  $dec, dec' \leftarrow \perp$ ;  $val \leftarrow \perp$ ;

(2) loop forever
(3)    $r \leftarrow r + 1$ ;
(4)    $SM[r].update(sm, val)$ ;
(5)    $sm \leftarrow SM[r].scan()$ ;
(6)   if ( $r = 1$ ) then
(7)      $sm \leftarrow input$ ;      /* 1st round: ignore write-snapshot */
(8)   else if ( $dec' = \perp$ ) then
(9)      $dec' \leftarrow \delta(sm, val)$ ;
(10)  end if
(11)   $val \leftarrow S[h_-(r, id, sm, val)].exec(v)$ ;
(12)  if ( $dec = \perp$ ) then
(13)     $dec \leftarrow dec'$ ;
(14)  end if
(15) end loop

```

Figure 5: General OWR-simulation protocol in the WRO iterated model

Transforming an OWR protocol into a WRO protocol

Now we show that any OWR protocol can be simulated with a WRO protocol. We follow the same technique that we used in the previous section, we use the generic protocol of Figure 5. The intuitive argument of how it works is very much the same as in the WRO case, thus we omit the details.

Theorem 4.8. *Let \mathcal{A} be a protocol in the WRO iterated model which solves a task Δ . Then \mathcal{A} can be simulated with a protocol \mathcal{B} in the OWR iterated model. Conversely, for every protocol \mathcal{B}' in the OWR iterated model that solves a task Δ' , there is a protocol \mathcal{A}' in the WRO iterated model, which simulates \mathcal{B}' .*

The equivalence of the WRO iterated model with the OWR iterated model can be combined with Theorem 4.4 to obtain the following

Corollary 4.9. *There is no protocol in the OWR iterated model for consensus using safe-consensus objects.*

The results of this section about the WRO and OWR iterated models combined with the consensus protocol using safe-consensus objects of [4], allow us to conclude that the standard model enriched with safe-consensus shared objects is more powerful than the WRO and OWR iterated models. But there are still some unanswered questions regarding these two iterated models, see our conclusions at Section 6.

5 Solving consensus in the WOR iterated model

In this section, We investigate the solvability of consensus in the WOR iterated model. We show that there exists a protocol in the WOR iterated model for consensus with $\binom{n}{2}$ safe-consensus objects. Although the formal specification of this protocol is a bit complicated (see Section 5.2), the intuitive idea behind it is quite simple and this idea can be depicted in a graphical way. This is a nice property of our consensus protocol and it is a consequence of working in an (extended) iterated model of computation. As a byproduct of the design of the consensus protocol, we discovered the new g -2coalitions-consensus task, which is a new kind of “consensus task”. More details can be found in Section 5.1. In Section 5.3, we present the main result

of this paper, the lower bound on the number of safe-consensus objects needed by any protocol in the WOR iterated model which implements consensus. The lower bound proof is a result of combining a careful study of the connectivity of protocols in the WOR iterated model and the effects of invoking safe-consensus shared objects on the indistinguishability degree of paths connecting reachable states of the protocols. These effects are described in part combinatorially by a new application of Johnson graphs in distributed computing. We use terminology and results from Sections 2 and 3. For simplicity, we refer to any protocol in the WOR iterated model as a WOR protocol.

5.1 The coalitions-consensus task

In order to present the complete specification of the consensus protocol, we define the 2coalition-consensus task, which will be useful to give a simpler description of the consensus protocol of Figure 8 and prove its correctness in Theorem 5.6, but before that, we show that the 2coalitions-consensus task can be solved in the WOR iterated model in one round with one snapshot object and one safe-consensus object.

Intuitively, in the g -2coalitions-consensus task, g processes try to decide a consensus value from two proposed input values, there are exactly $g - 2$ processes which know the two input values, while each of the two remaining processes know only one input value and it is this last fact that makes the 2coalitions-consensus task difficult to solve. We now give the formal definition of this new task. First, we need to define the set of all valid input values for this new task.

Let I be a non-empty set of names such that $\perp \notin I$ and $\mathcal{N} = I \cup \{\perp\}$. If $x = \langle v_1, v_2 \rangle \in \mathcal{N} \times \mathcal{N}$, $x.left$ denotes the value v_1 and $x.right$ is the value v_2 . If $g \in \mathbb{N}$, then an ordered g -tuple $C = (x_1, \dots, x_g) \in (\mathcal{N} \times \mathcal{N})^g$ is a g -coalitions tuple if and only if

- (a) For all x_i in C , $x_i.left \neq \perp$ or $x_i.right \neq \perp$.
- (b) If x_i, x_j are members of C such that $x_i.left \neq \perp$ and $x_j.left \neq \perp$, then $x_i.left = x_j.left$. A similar rule must hold if $x_i.right \neq \perp$ and $x_j.right \neq \perp$.

Let $l(C) = \{i \in \bar{g} \mid x_i.left \neq \perp\}$ and $r(C) = \{j \in \bar{g} \mid x_j.right \neq \perp\}$. Then we also require that

- (c) $|l(C) - r(C)| = 1$ and $r(C) - l(C) = \{g\}$.

Notice that property (a) implies that $l(C) \cup r(C) = \bar{g}$. The set of all g -coalitions tuples is denoted by \mathcal{C}_g . Some examples can help us understand better the concept of a coalition tuple. Let $\mathcal{N} = \{0, 1, \perp\}$. The following tuples are examples of elements of the set \mathcal{C}_4 ,

$$C_1 = (\langle 1, \perp \rangle, \langle 1, 0 \rangle, \langle 1, 0 \rangle, \langle \perp, 0 \rangle);$$

$$C_2 = (\langle 1, 0 \rangle, \langle 1, 0 \rangle, \langle 1, \perp \rangle, \langle \perp, 0 \rangle).$$

Clearly, $C_1, C_2 \in \mathcal{C}_4$ and also we have that $l(C_1) = \{1, 2, 3\}$ and $r(C_1) = \{2, 3, 4\}$. Notice that $l(C_1) \cup r(C_1) = \bar{4}$ and also $l(C_1) \cap r(C_1) = \{2, 3\}$. For C_2 , it is true that $l(C_2) - r(C_2) = \{1, 2, 3\} - \{1, 2, 4\} = \{3\}$, $r(C_2) - l(C_2) = \{1, 2, 4\} - \{1, 2, 3\} = \{4\}$ and $l(C_2) \cap r(C_2) = \{1, 2\}$. The following tuples are not elements of any coalitions tuples set:

$$C_3 = (\langle \perp, \perp \rangle, \langle 1, 0 \rangle, \langle 1, 0 \rangle, \langle 1, 0 \rangle);$$

$$C_4 = (\langle 1, \perp \rangle, \langle 1, 0 \rangle, \langle \perp, 1 \rangle, \langle \perp, 0 \rangle).$$

For C_3 , properties (a) and (c) are not satisfied and for C_4 , condition (b) is not fulfilled. Thus we conclude that $C_3, C_4 \notin \mathcal{C}_4$. We can now define a new distributed task.

The g -2coalitions-consensus task We have g processes p_1, \dots, p_g and each process p_i starts with a private input value of the form $x_i \in \mathcal{N} \times \mathcal{N}$ such that $C = (x_1, \dots, x_g) \in \mathcal{C}_g$, and C is called a *global input*. In any execution, the following properties must be true:

- Termination: Each process must eventually output some value.
- Agreement: All processes output the same value.
- 2coalitions-Validity: If some process outputs c , then there must exist a process p_j with input x_j such that $x_j = \langle c, v \rangle$ or $x_j = \langle v, c \rangle$ ($c \in I, v \in \mathcal{N}$).

Notice that the sets \mathcal{C}_g ($g \geq 2$) encapsulate the intuitive ideas given at the beginning of this section about the coalition-consensus task that we need: With an input $C \in \mathcal{C}_g$, there are two processes that know exactly one of the input values, while the rest of the processes do not know the two input values. These processes could easily reach a consensus, but they still need the other two processes with unique input values to agree on the same value, and this is the difficult part of the g -2coalitions-consensus task.

The protocol of Figure 6 implements g -2coalitions-consensus. Each process p_i receives as input a tuple with values satisfying the properties of the 2coalitions-consensus task and then in lines 3-5, p_i writes its input tuple in shared memory using the snapshot object SM ; invokes the safe-consensus object with its id as input, storing the unique output value u of the shared object in the local variable val and finally, p_i takes a snapshot of the memory. Later, what happens in Lines 6-10 depends on the output value u of the safe-consensus object. If $u = g$, then by the Safe-Validity property, either p_g invoked the object or at least two processes invoked the safe-consensus object concurrently and as there is only one process with input tuple $\langle v, \perp \rangle$, p_i will find an index j with $sm[j].right \neq \perp$ in line 7, assign this value to dec and in line 11 p_i decides. On the other hand, if $u \neq g$, then again by the Safe-Validity condition of the safe-consensus task, either process p_u is running and invoked the safe-consensus object or two or more processes invoked concurrently the shared object and because all processes with id not equal to g have input tuple $\langle z, y \rangle$ with $z \neq \perp$, it is guaranteed that p_i can find an index j with $sm[j].left \neq \perp$ and assign this value to dec to finally execute line 11 to decide its output value. All processes decide the same value because of the properties of the input tuples of the 2coalitions-consensus task and the Agreement property of the safe-consensus task.

```

(1) procedure  $g$ -2coalitions-consensus( $v_1, v_2$ )
(2) begin
(3)    $SM.update(\langle v_1, v_2 \rangle)$ ;
(4)    $val \leftarrow safe-consensus.exec(id)$ ;
(5)    $sm \leftarrow SM.scan()$ ;
(6)   if  $val = g$  then
(7)      $dec \leftarrow$  choose any  $sm[j].right \neq \perp$ ;
(8)   else
(9)      $dec \leftarrow$  choose any  $sm[j].left \neq \perp$ ;
(10)  end if
(11)  decide  $dec$ ;
(12) end
```

Figure 6: A g -2coalitions-consensus protocol with one safe-consensus object.

We now prove that this g -2coalitions-consensus protocol is correct.

Lemma 5.1. *The protocol of Figure 6 solves the g -2coalitions-consensus task using one snapshot object and one safe-consensus object.*

Proof. Let $p_i \in \{p_1, \dots, p_g\}$; after p_i writes the tuple $\langle v_1, v_2 \rangle$ to the snapshot object SM , it invokes the safe-consensus object and takes a snapshot of the shared memory, p_i enters into the **if/else** block at lines 6-10. Suppose that the test in line 6 is successful, this says that the safe-consensus object returned the value g to process p_i . By the Safe-Validity condition of the safe-consensus task, either process p_g invoked the shared object or at least two processes p_j, p_k invoked the safe-consensus object concurrently (and it could happen that $j, k \neq g$). In any case, the participating processes wrote their input tuples to the snapshot object SM before accessing the safe-consensus object, so that p_i can see these values in its local variable sm_i , and remember that the coalitions tuple C consisting of all the input values of processes p_1, \dots, p_g satisfies the properties

$$|l(C) - r(C)| = 1 \text{ and } r(C) - l(C) = \{g\}.$$

Thus, the equation $|l(C) - r(C)| = 1$ tells us that only one process has input tuple $\langle x, \perp \rangle$ ($x \neq \perp$), then when p_i executes line 7, it will find a local register in sm_i such that $sm_i[j].right \neq \perp$ and this value is assigned to dec_i . Finally, p_i executes line 11, where it decides the value stored in dec_i and this variable contains a valid input value proposed by some process.

If the test at line 6 fails, the argument to show that dec_i contains a valid proposed input value is very similar to the previous one. This proves that the protocol satisfies the 2coalitions-Validity condition of the g -2coalitions-consensus task.

The Agreement condition is satisfied because by the Agreement condition of the safe-consensus task, all participating processes receive the same output value from the shared object and therefore all processes have the same value in the local variables val_i ($1 \leq i \leq g$), which means that all participating processes execute line 7 or all of them execute line 9. Then, for every process p_r , dec_r contains the value $sm_r[j_r].right$ or the value $sm_r[j'_r].left$ where j_r (j'_r) depends on p_r . But because the input pairs of the processes constitute a coalitions tuple C , they satisfy property (b) of the definition of coalitions tuple, which implies that $sm_r[j_r].right = sm_r[j_q].right$ whenever $sm_r[j_r].right$ and $sm_r[j_q].right$ are non- \perp (a similar statement holds for the left sides). We conclude that all processes assign to the variables dec_i ($1 \leq i \leq g$) the same value and thus all of them decide the same output value, that is, the Agreement property of the g -2coalitions-consensus tasks is fulfilled. The Termination property is clearly satisfied. \square

5.2 The WOR protocol for consensus

We first give an intuitive description of the WOR protocol for consensus, using 2coalitions-consensus shared objects and then we introduce the formal specification and prove its correctness.

Intuitive description

A simple way to describe the protocol that solves consensus is by seeing it as a protocol in which the processes use a set of $\binom{n}{2}$ shared objects which implement our new g -2coalitions-consensus task. In this way, the protocol in Figure 8 can be described graphically as shown in Figure 7, for the case of $n = 4$. In each round of the protocol, some processes invoke a 2coalitions-consensus object, represented by the symbol $2CC_i$. In round one, p_1 and p_2 invoke the object $2CC_1$ with input values $\langle v_1, \perp \rangle$ and $\langle \perp, v_2 \rangle$ respectively, (where v_i is the initial input value of process p_i) and the consensus output u_1 of $2CC_1$ is stored by p_1 and p_2 in some local variables. In round two, p_2 and p_3 invoke the $2CC_2$ object with inputs $\langle v_2, \perp \rangle$ and $\langle \perp, v_3 \rangle$ respectively and they keep the output value u_2 in local variables. Round three is executed by p_3 and p_4 in a similar way, to obtain the consensus value u_3 from the 2coalition-consensus object $2CC_3$. At the beginning of round four, p_1, p_2 and p_3 gather the values u_1, u_2 obtained from the objects $2CC_1$ and $2CC_2$ to invoke the $2CC_4$ 2coalition-consensus object with the input values $\langle u_1, \perp \rangle, \langle u_1, u_2 \rangle$ and $\langle \perp, u_2 \rangle$ respectively (Notice that

p_2 uses a tuple with both values u_1 and u_2) and they obtain a consensus value u_4 . Similar actions are taken by the processes p_2, p_3 and p_4 in round five with the shared object $2CC_5$ and the values u_2, u_3 to compute an unique value u_5 . Finally, in round six, all processes invoke the last shared object $2CC_6$, with the respective input tuples

$$\langle u_4, \perp \rangle, \langle u_4, u_5 \rangle, \langle u_4, u_5 \rangle, \langle \perp, u_5 \rangle,$$

and the shared object returns to all processes an unique output value u , which is the decided output value of all processes, thus this is the final consensus of the processes.

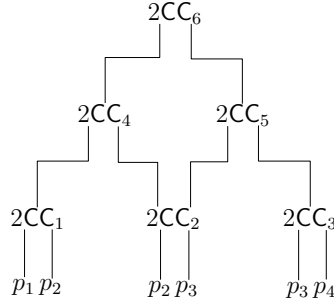

Figure 7: The structure of the 4-consensus protocol using 2coalitions-consensus tasks.

Formal specification

The formal specification of the iterated consensus protocol with safe-consensus objects is given in Figure 8. This is a protocol that implements consensus using only $\binom{n}{2}$ 2coalitions-consensus tasks. If we suppose that the protocol is correct, then we can use the g -2coalitions-consensus protocol presented in Section 5.1 (Figure 6) to replace the call to the 2coalitions-consensus objects in Figure 8 to obtain a full iterated protocol that solves the consensus task using $\binom{n}{2}$ safe-consensus objects.

We now give a short description of how the protocol works. There are precisely $\binom{n}{2}$ rounds executed by the processes and in each round, some subset of processes try to agree in a new consensus value among two given input values. The local variables *step*, *firstid* and *lastid* are used by the processes to store information that tell them which is the current set of processes that must try to reach a new agreement in the current round, using a 2coalitions-consensus object (the symbol "id" contains the id of the process which is executing the code). The local array *agreements* contains enough local registers used by the processes to store the agreements made in each round of the protocol and two distinct processes can have different agreements in *agreements*. Each consensus value v stored in a register of *agreements* is associated with two integers $i_1, i_r \in \bar{n}$ ($r \geq 1$), which represent a set of processes p_{i_1}, \dots, p_{i_r} (with $i_1 < \dots < i_r$) that have invoked a 2coalitions-consensus object to agree on the value v , thus we can say that v is an agreement made by the coalition of processes represented by the pair (i_1, i_r) . To be able to store v in the array *agreements*, the processes use a deterministic function **tup**: $\mathbb{N} \times \mathbb{N} \rightarrow \mathbb{N}$, which maps bijectively $\mathbb{N} \times \mathbb{N}$ onto \mathbb{N} . This map can be easily constructed, for example, here is a simple definition for **tup**

$$\mathbf{tup}(i, j) = \binom{i+j+1}{2} + j. \quad (1)$$

Using all the elements described above, the processes can use the protocol of Figure 8 to implement consensus using $\binom{n}{2}$ 2coalitions-consensus objects, building in the process the structure depicted in Figure

```

(1) init  $step, firstid, lastid \leftarrow 1$ ;
       $C, D, dec, newagreement \leftarrow \perp$ ;
       $agreements[\mathbf{tup}(id, id)] \leftarrow input$ ;

(2) begin
(3)   for  $r \leftarrow 1$  to  $\binom{n}{2}$ 
(4)      $lastid \leftarrow firstid + step$ ;
(5)     if  $firstid \leq id \leq lastid$  then
(6)        $C \leftarrow agreements[\mathbf{tup}(firstid, lastid - 1)]$ ;
(7)        $D \leftarrow agreements[\mathbf{tup}(firstid + 1, lastid)]$ ;
(8)        $newagreement \leftarrow 2coalitions-consensus[r](C, D)$ ;
(9)        $agreements[\mathbf{tup}(firstid, lastid)] = newagreement$ ;
(10)    end if
(11)    if  $lastid < n$  then
(12)       $firstid = firstid + 1$ ;
(13)    else if  $firstid > 1$  then
(14)       $firstid = 1$ ;
(15)       $step = step + 1$ ;
(16)    end if
(17)  end for
(18)   $dec \leftarrow agreements[\mathbf{tup}(1, n)]$ ;
(19)  decide  $dec$ ;
(20) end

```

Figure 8: An iterated consensus protocol using g -2coalitions-consensus objects.

7. From the first round and up to round $n - 1$, all the processes use their proposed input values to make new agreements in pairs, in round one, p_1, p_2 invoke a 2coalitions-consensus shared object to agree on a common value, based on their input values; in round 2, p_2 and p_3 do the same with another 2coalitions-consensus object and their own input values; later, the turn comes to p_3 and p_4 to do the same with another shared object and their input values and so on until the round number $n - 1$, where p_{n-1} and p_n agree on a common value in the way that we have already described. All the agreements obtained in these $n - 1$ rounds are stored on the local registers

$$\begin{aligned}
& agreements_1[\mathbf{tup}(1, 2)], agreements_2[\mathbf{tup}(1, 2)], agreements_2[\mathbf{tup}(2, 3)], \\
& agreements_3[\mathbf{tup}(2, 3)], agreements_3[\mathbf{tup}(3, 4)], agreements_4[\mathbf{tup}(3, 4)], \\
& \dots, \\
& agreements_{n-1}[\mathbf{tup}(n-1, n)], agreements_n[\mathbf{tup}(n-1, n)]. \quad (2)
\end{aligned}$$

In this way, the processes build the first part of the structure shown in Figure 7. At the end of round $n - 1$, in lines 14-15, each process updates the values of the local variables $step$ and $firstid$ and proceeds to round n . What happens in the next $n - 2$ rounds, is very similar to the case of the previous $n - 1$ rounds, but instead of making agreements in pairs, the processes reach new agreements in groups of three processes (see Figure 7) invoking new 2coalitions-consensus shared objects and the consensus values obtained in the first $n - 1$ rounds and when each process reaches round $n - 1 + n - 2 = 2n - 3$, it updates the values of its local variables $step$ and $firstid$ and then the processes proceed to round $2n - 2$.

In general, when the processes are about to begin executing round $(\sum_{j=1}^m n - j) + 1$ ($m < n$), they will try to make $n - (m + 1)$ new agreements in groups of size $m + 2$, with the aid of the 2coalitions-consensus objects and the agreements they obtained from the previous $n - m$ rounds and store the new consensus values in their local arrays *agreements*, using the **tup** function. When a process finishes round $(\sum_{j=1}^{m+1} n - j)$, the values of *step* and *firstid* are updated to repeat the described behaviour for the next $n - (m + 2)$ rounds, until the $\binom{n}{2}$ round, where the last agreement is made and this value is the output value of all the processes.

Now we are ready to give the full proof of Theorem 5.6. We need a series of Lemmas.

Lemma 5.2. *The protocol in Figure 8 solves the consensus task using $\binom{n}{2}$ g-2coalitions-consensus objects.*

Proof. The protocol clearly satisfies the Termination condition of the consensus task (the only loop is finite). We prove that it fulfils the Agreement and Validity conditions; to do this, we need some definitions and some intermediate results.

With respect to the protocol of Figure 8, let $F = \{i_1, \dots, i_r\} \subseteq \bar{n}$ be elements such that $i_1 < \dots < i_r$. The set F will be called a *coalition* and will be denoted by $F = [i_1, \dots, i_r]$. Let p_i a process such that $i \in F$. We say that p_i belongs to the coalition F if and only if the following condition is fulfilled:

- (1) $agreements_i[\mathbf{tup}(i_1, i_r)] = v$, where $v \neq \perp$ is a valid input value proposed by some participating process.

We ask the following *agreement* property to be satisfied by F :

- (2) if p_i, p_j are processes which belong to F and v, v' are the values which satisfy (1) for p_i and p_j respectively, then $v = v'$.

The value v of the first condition is called the *name* of the coalition. The second condition says that all processes that belong to the same coalition must agree on the coalition's name. For $n > m \geq 0$, let $\gamma(n, m)$ be defined by

$$\gamma(n, m) = \begin{cases} 0 & \text{if } m = 0, \\ \gamma(n, m - 1) + n - m & \text{if } m > 0. \end{cases}$$

Notice that $\gamma(n, m) = \sum_{i=1}^m n - i$ for $m > 0$ and $\gamma(n, n - 1) = \binom{n}{2}$.

Lemma 5.3. *Let $1 \leq m \leq n - 1$ and $1 \leq c \leq n - m$. If p_i is executing the protocol at the beginning of round number $r = \gamma(n, m - 1) + c$ (before line 11) then $step_i = m$ and $firstid_i = c$.*

Proof. We prove this by induction on m . An easy analysis of the code in Figure 8 shows that the base case holds (when $m = 1$, in the first $n - 1$ rounds). Assume that for $m < n - 1$, the lemma is true. We first prove the following claim: When p_i starts executing round $\gamma(n, m) + 1$, $step_i = m + 1$ and $firstid_i = 1$. By the induction hypothesis, when process p_i executed the protocol at round $r' = \gamma(n, m) = \gamma(n, m - 1) + c = \gamma(n, m - 1) + (n - m)$ before line 11, the local variables $step_i$ and $firstid_i$ had the values of m and $n - m$ respectively. When p_i reached line 11, it executed the test of the **if** statement, but before that, p_i executed line 4 of the protocol, gather that, $lastid_i = firstid_i + step_i = (n - m) + m = n$; thus the test in line 11 failed and p_i executed lines 14-15 of the **else** statement ($firstid_i > 1$ because $m < n - 1$) and then $step_i$ was incremented by one and $firstid_i$ was set to 1 at the end of round r' . Therefore, when p_i starts executing round $\gamma(n, m) + 1$, $step_i = m + 1$ and $firstid_i = 1$.

Now suppose that p_i executes the protocol at the beginning of round number $r = \gamma(n, m) + c$ where $1 \leq c \leq n - (m + 1)$. If $c = 1$ then by the preceding argument, $step_i = m + 1$ and $firstid_i = 1 = c$. Using this as a basis for an inductive argument, we can prove that for $c \in \{1, \dots, n - (m + 1)\}$, $c = firstid_i$ and $step_i = m + 1$. \square

Lemma 5.4. *Let $0 \leq m \leq n - 2$. Suppose that process p_i is about to begin executing the protocol at round $r = \gamma(n, m) + c$ ($1 \leq c \leq n - (m + 1)$). If $c \leq i \leq c + m + 1$ and p_i belongs to the coalition $P = [c, \dots, c + m]$ or it belongs to the coalition $Q = [c + 1, \dots, c + m + 1]$, then at the end of round r , p_i belongs to the coalition $[c, \dots, c + m + 1]$.*

Proof. Let p_i be any process that begins executing round r . By Lemma 5.3, we know that $step_i = m + 1$ and $firstid_i = c$, which implies that $lastid_i = c + m + 1$. If $i \in \{c, \dots, c + m + 1\}$, the **if**'s test at line 5 is successful and after that what happens in lines 6,7 depends on i . If $c \leq i \leq c + m$, then p_i is in the coalition P and if $c + 1 \leq i \leq c + m + 1$, p_i is in the coalition Q , gather that, a valid input value is assigned to at least one of the variables C_i or D_i , so p_i invokes in line 8 the $(m + 2)$ -2coalitions-consensus object with the input $x_i = \langle C_i, D_i \rangle$. We now pause for a moment to argue that the tuple $J = (x_c, \dots, x_{c+m+1})$ built with the inputs of processes p_c, \dots, p_{c+m+1} is a valid global input for the $(m + 2)$ -2coalitions-consensus task. Indeed, from the hypothesis, it is easy to see that J satisfies the requirements (a)-(c) of the definition of coalition tuple and notice that $r(J) - l(J) = \{c + m + 1\}$ and $l(J) - r(J) = \{c\}$.

Now back to the execution of process p_i . After p_i invokes the $(m + 2)$ -2coalitions-consensus task, the return value of the shared object, say v , is assigned to the local variable $newagreement_i$. Finally, p_i stores the contents of $newagreement_i$ in the local array $agreements_i$ at position **tup**($firstid_i, lastid_i$), where $firstid_i = c$ and $lastid_i = c + m + 1$. Because of the Agreement condition of the 2coalitions-consensus task, every process with id in the set $\{c, \dots, c + m + 1\}$ obtained the same value v as return value from the shared object and by the 2coalitions-Validity, this is a valid input value proposed by some process. Therefore process p_i belongs to the coalition $[c, \dots, c + m + 1]$ at the end of round r .

On the other hand, if $i \notin \{c, \dots, c + m + 1\}$, p_i does not execute the body of the **if** statement (lines 6 to 9) and it goes on to execute the **if/else** block at lines 11-16 and then round r ends for p_i , thus it does not try to make a new coalition with other processes. \square

Lemma 5.5. *Let $m \in \{0, \dots, n - 2\}$. Suppose that process p_j has executed the protocol for $\gamma(n, m)$ rounds and that there exists $i \in \{1, \dots, n - (m + 1)\}$ such that p_j belongs to the coalition $[i, \dots, i + m]$ or it belongs to the coalition $[i + 1, \dots, i + m + 1]$. Then after p_j has executed the protocol for $n - (m + 1)$ more rounds, p_j belongs to the coalition $[i, \dots, i + m + 1]$.*

Proof. We apply Lemma 5.4 in each round $\gamma(n, m) + c$, where $c \in \{1, \dots, n - (m + 1)\}$. \square

Now we can complete the proof of Lemma 5.2. Let p_j be any process that executes the protocol. Just at the beginning of the first round (line 2), process p_j belongs to the coalition $[j]$ (because of the assignments made to the local array $agreements_j$ in line 1, so that if p_j executes the protocol for $\gamma(n, 1) = n - 1$ rounds, we can conclude using Lemma 5.5, that process p_j belongs to some of the coalitions $[i, i + 1]$ ($1 \leq i \leq n - 1$). Starting from this fact and using induction on m , we can prove that for all $m = 1, \dots, n - 1$; at the end of round $\gamma(n, m)$, p_j belongs to some of the coalitions $[i, \dots, i + m]$ ($1 \leq i \leq n - m$). In the last round (when $m = n - 1$), after executing the main **for** block, process p_j belongs to the coalition $T = [1, \dots, n]$, thus when p_j executes line 18, it will assign to the local variable dec_i a valid proposed input value and this is the value decided by p_j at line 19. All processes decide the same value because all of them are in the coalition T . Therefore the protocol satisfies the Agreement and Validity conditions of the consensus task. \square

The final result of this section is obtained by combining Lemmas 5.1 and 5.2.

Theorem 5.6. *There exists a WOR protocol that solves the consensus task for n processes using $\binom{n}{2}$ safe-consensus objects.*

5.3 The lower bound

The main result of this paper is a matching lower bound on the number of safe-consensus objects needed to solve consensus using safe-consensus. Our lower bound proof is based partly on standard bivalency arguments [2], but in order to be able to apply them, a careful combinatorial work is necessary.

The connectivity of iterated protocols with safe-consensus.

Roughly speaking, a typical consensus impossibility proof shows that a protocol \mathcal{A} cannot solve consensus because there exists one execution of \mathcal{A} in which processes decide a consensus value v and a second execution of \mathcal{A} where the consensus output of the processes is v' , with $v \neq v'$, such that the global states of these executions can be connected with paths of connected states. The existence of such paths will imply that in some execution of \mathcal{A} , some processes decide distinct output values [2, 3, 8, 29], violating the Agreement requirement of consensus. Any protocol that solves consensus, must be able to destroy these paths of connected states.

Remember from Section 3.5 that the set $\Gamma_{\mathcal{A}}(n, m)$ encodes all the valid subsets of processes of size m that can invoke safe-consensus objects in \mathcal{A} . The cardinality of $\Gamma_{\mathcal{A}}(n, m)$ is denoted by $v_{\mathcal{A}}(n, m)$ and

$$v_{\mathcal{A}}(n) = \sum_{m=2}^n v_{\mathcal{A}}(n, m).$$

For the case of our lower bound proof, the main property that will prevent \mathcal{A} from solving consensus (i.e., from destroying paths of connected states) is that for some $m_0 \in \{2, \dots, n\}$, it is true that

$$v_{\mathcal{A}}(n, m_0) \leq n - m_0, \tag{3}$$

i.e., at most $n - m_0$ subsets of processes of size m_0 can invoke safe-consensus shared objects in the protocol \mathcal{A} . We are ready to present our main result, it is the following

Theorem 5.7. *If \mathcal{A} is a WOR protocol for n -consensus using safe-consensus objects, then for every $m \in \{2, \dots, n\}$, $v_{\mathcal{A}}(n, m) > n - m$.*

Theorem 5.7 describes the minimum number of different process groups, each of size m , that must invoke safe-consensus shared objects, in order to be able to solve the consensus task, for each $m = 2, \dots, n$. The lower bound on the total number of safe-consensus objects necessary to implement consensus, is an easy consequence of Theorem 5.7 and the definition of $v_{\mathcal{A}}(n)$.

To understand better the implications of Theorem 5.7 on the minimum number of safe-consensus shared objects needed to implement n -consensus, here is an example: Let $n = 5$ and suppose \mathcal{A} is a WOR protocol that solves 5-consensus. By Theorem 5.7, for each $m = 2, 3, 4, 5$, \mathcal{A} satisfies the following inequalities:

$$v_{\mathcal{A}}(5, 2) > 5 - 2 = 3,$$

$$v_{\mathcal{A}}(5, 3) > 5 - 3 = 2,$$

$$v_{\mathcal{A}}(5, 4) > 5 - 4 = 1,$$

$$v_{\mathcal{A}}(5, 5) > 5 - 5 = 0.$$

In words, There must be at least 4 groups of 2 processes that invoke safe-consensus objects, 3 groups of 3 processes that invoke safe-consensus objects, 2 groups of 4 processes and finally, a group of 5 processes (e.g., all the processes) that must invoke a safe-consensus object. Thus the minimum total number of safe-consensus shared objects that the processes must invoke in \mathcal{A} to implement consensus is

$$\begin{aligned}
v_{\mathcal{A}}(5) &= v_{\mathcal{A}}(5,2) + v_{\mathcal{A}}(5,3) + v_{\mathcal{A}}(5,4) + v_{\mathcal{A}}(5,5) \\
&\geq 4 + 3 + 2 + 1 \\
&= 10 \\
&= \binom{5}{2}.
\end{aligned}$$

Generalizing this example for arbitrary n , we obtain the inequality $v_{\mathcal{A}}(n) \geq \binom{n}{2}$. Notice that we are not counting trivial boxes (safe-consensus objects invoked by one process) in the lower bound.

Theorem 5.7 will be proven by contradiction, that is, we will assume that for some m_0 , Equation (3) holds. There are two structural results about WOR protocols that will be needed: Lemmas 5.16 and 5.19. Basically, these two results tell us how to find paths of connected reachable states in every round of an executing WOR protocol, whenever Equation (3) is satisfied. The proof of each lemma relies on the development of various results about the connectivity of states of WOR protocols with safe-consensus shared objects and additionally, these results give us information about the combinatorial interactions that exists between the sets of processes which cannot distinguish between the states of a path and the boxes that represent safe-consensus objects invoked by the processes. This extra information is provided by two results about the connectivity of subgraphs of Johnson graphs, Lemma 5.17 and Theorem 5.13. Since the theory and prior results needed to prove these two results are purely combinatorial, we defer their formal proofs to Appendix A.

Further model terminology

We will be using definitions and terminology given in Sections 2 and 3. Before giving the formal proof of our results, we need some technical definitions and lemmas. First, we define a set of round schedules that will be very useful for the rest of the paper. Given $q \geq 1$ disjoint sets $A_1, \dots, A_q \subset \bar{n}$, define the round schedule $\xi(A_1, \dots, A_q)$ for \mathcal{A} as:

$$W(A_1), S(A_1), R(A_1), \dots, W(A_q), S(A_q), R(A_q), W(Y), S(Y), R(Y), \quad (4)$$

where $Y = \bar{n} - (\bigcup_{i=1}^q A_i)$. For any state S and $u \geq 0$, define

$$S \cdot \xi^u(A_1, \dots, A_q) = \begin{cases} S & \text{if } u = 0, \\ (S \cdot \xi^{u-1}(A_1, \dots, A_q)) \cdot \xi(A_1, \dots, A_q) & \text{otherwise.} \end{cases}$$

I.e. $S \cdot \xi^u(A_1, \dots, A_q)$ is the state that we obtain after we run the protocol \mathcal{A} (starting from S) u rounds with the round schedule $\xi(A_1, \dots, A_q)$ each iteration.

Let \mathcal{A} be a WOR protocol for n -processes, $X \subseteq \bar{n}$, R a state of some round $r > 0$ and $b \in \mathbf{Inv}(R)$. We say that R is a *ladder state for X with step b* , if $R = S \cdot \xi(C_1, \dots, C_u, B)$ ($u \geq 0$), where S is a reachable state in \mathcal{A} and

- $X = (\bigcup_j^u C_j) \cup B$;
- for $j = 1, \dots, u$, $0 \leq |C_j| \leq 2$;

- $(\bigcup_j^u C_j) \cap b = \emptyset$;
- $B = b \cap X$.

The following definition is given for convenience. For each box b_i and $W \subseteq \bar{n}$, let the set $W_{(i)}$ be defined as

$$W_{(i)} = W \cap b_i. \quad (5)$$

Lemma 5.8. *Let \mathcal{A} be a WOR protocol for $n \geq 2$ processes with safe-consensus objects and S a reachable state in \mathcal{A} . Then for any two round schedules π_1, π_2 , $\mathbf{Inv}(S \cdot \pi_1) = \mathbf{Inv}(S \cdot \pi_2)$.*

Proof. In Figure 3, notice that process p_i executes the deterministic function h with the local state it has from the previous round (except from the round counter r), so that if r is the round number of S and p_i starts executing the protocol \mathcal{A} in round $r+1$ with the local state it had in S , the input to the function h is given by the tuple $(r+1, i, sm_S, val_S)$, where sm_S, val_S depend only on S . Thus in both successor states $S \cdot \pi_1$ and $S \cdot \pi_2$, p_i feeds the same input to h , gather that

$$\mathbf{Inv}(S \cdot \pi_1) = \mathbf{Inv}(S \cdot \pi_2)$$

and the lemma is true. □

5.4 The local structure of WOR protocols with safe-consensus objects

In this section, we present results that will be needed to prove Lemma 5.16. The goal here is to show Theorem 5.12, which give us a way to connect two states of the form $S \cdot \xi(X)$ and $S \cdot \xi(Y)$ for $X, Y \subseteq \bar{n}$ and any reachable state S of a WOR protocol. Put it another way, with Theorem 5.12 we can connect for a given WOR protocol, a state that is obtained if the processes with ids in X first update the memory, invoke safe-consensus objects and finally they snapshot the shared memory and after that, processes with ids in $\bar{n} - X$ perform the same actions, with a state that is obtained when processes with ids in Y and ids in $\bar{n} - Y$ perform the same action in the same way. All this is done with a careful handling of the safe-consensus values returned by the shared objects to the processes, in order to keep the degree of indistinguishability of the path as high as possible. The ladder states defined previously play an important role in the construction of the path given by Theorem 5.12.

Lemma 5.9. *Let $n \geq 2$, $\emptyset \neq X \subseteq \bar{n}$, \mathcal{A} a WOR protocol with safe-consensus objects, S a state that is reachable in \mathcal{A} in some round $r \geq 0$ and $b \in \mathbf{Inv}(S_X)$, where $S_X = S \cdot \xi(X)$. Then there exists a state L , such that L is a ladder state for X with step b , such that S_X and L are connected in round $r+1$ with a path of states \mathfrak{p} with $\text{deg } \mathfrak{p} \geq n-2$.*

Proof. Let $\mathbf{Inv}(S_X) = \{b_1, \dots, b_q\}$ ($q \geq 1$). By Lemma 5.8, for any one-round successor state Q of S , $\mathbf{Inv}(Q) = \mathbf{Inv}(S_X)$ and we can write \mathbf{Inv}_S instead of $\mathbf{Inv}(S_X)$. Without loss of generality, assume that $b_1 = b$. If $q = 1$, then $b_1 = \bar{n}$ and the result is immediate, because S_X is a ladder state for X with step \bar{n} . Suppose that $q > 1$. Partition X as $X = X_{(1)} \cup \dots \cup X_{(q)}$ and build the following sequence of connected states

$$\begin{aligned}
& S_X \stackrel{\bar{n}-\Lambda_2(1)}{\approx} S \cdot \xi(\Lambda_2(1), X - \Lambda_2(1)) \\
& \quad \quad \quad \stackrel{\bar{n}-\Lambda_2(2)}{\approx} S \cdot \xi(\Lambda_2(1), \Lambda_2(2), X - (\Lambda_2(1) \cup \Lambda_2(2))) \\
& \quad \quad \quad \quad \quad \quad \stackrel{\bar{n}-\Lambda_2(3)}{\approx} \dots \stackrel{\bar{n}-\Lambda_2(\alpha_2)}{\approx} \\
& \quad \quad \quad \quad \quad \quad \quad \quad \quad S \cdot \xi(\Lambda_2(1), \Lambda_2(2), \dots, \Lambda_2(\alpha_2), X - X_{(2)}), \quad (6)
\end{aligned}$$

where $X_{(2)} = \bigcup_{i=1}^{\alpha_2} \Lambda_2(i)$ is a partition of $X_{(2)}$ such that $|\Lambda_2(j)| = 1$ for $j = 2, \dots, \alpha_2$. The set $\Lambda_2(1)$ has cardinality given by

$$|\Lambda_2(1)| = \begin{cases} 2 & \text{if } |X_{(2)}| > 1, \\ |X_{(2)}| & \text{otherwise,} \end{cases}$$

(notice that the $\Lambda_2(j)$'s and α_2 depend on b_2 and $X_{(2)}$), and we choose the safe-consensus value of every box in the set \mathbf{Inv}_S to be the same in each state of the previous sequence. This can be done because of the way we partition $X_{(2)}$, the election of the elements of the set $\Lambda_2(1)$ and the properties of the safe-consensus task (Safe-Validity). We execute similar steps with box b_3 , so that we obtain the path

$$\begin{aligned} & S \cdot \xi(\Lambda_2(1), \dots, \Lambda_2(\alpha_2), X - X_{(2)}) \\ & \quad \bar{n} \underset{\sim}{\sim}^{\Lambda_3(1)} S \cdot \xi(\Lambda_2(1), \dots, \Lambda_2(\alpha_2), \Lambda_3(1), X - (X_{(2)} \cup \Lambda_3(1))) \\ & \quad \bar{n} \underset{\sim}{\sim}^{\Lambda_3(2)} S \cdot \xi(\Lambda_2(1), \dots, \Lambda_2(\alpha_2), \Lambda_3(1), \Lambda_3(2), X - (X_{(2)} \cup \Lambda_3(1) \cup \Lambda_3(2))) \\ & \quad \quad \quad \bar{n} \underset{\sim}{\sim}^{\Lambda_3(3)} \dots \bar{n} \underset{\sim}{\sim}^{\Lambda_3(\alpha_3)} \\ & \quad S \cdot \xi(\Lambda_2(1), \dots, \Lambda_2(\alpha_2), \Lambda_3(1), \dots, \Lambda_3(\alpha_3), X - (X_{(2)} \cup X_{(3)})), \quad (7) \end{aligned}$$

where the $\Lambda_3(i)$'s and α_3 depend on b_3 and $X_{(3)}$, just in the same way the $\Lambda_2(j)$'s and α_2 depend on b_2 and $X_{(2)}$ and each box has safe-consensus value equal to the value it has in the sequence of (6). We can repeat the very same steps for b_4, \dots, b_q to obtain the sequence

$$\begin{aligned} & S \cdot \xi(\Lambda_2(1), \dots, \Lambda_3(\alpha_3), X - (X_{(2)} \cup X_{(3)})) \\ & \quad \bar{n} \underset{\sim}{\sim}^{\Lambda_4(1)} S \cdot \xi(\Lambda_2(1), \dots, \Lambda_3(\alpha_3), \Lambda_4(1), X - (X_{(2)} \cup X_{(3)} \cup \Lambda_4(1))) \\ & \quad \quad \quad \bar{n} \underset{\sim}{\sim}^{\Lambda_4(2)} \dots \bar{n} \underset{\sim}{\sim}^{\Lambda_4(\alpha_4)} \\ & \quad S \cdot \xi(\Lambda_2(1), \dots, \Lambda_q(1), X - (\Lambda_q(1) \cup \bigcup_{i=2}^{q-1} X_{(i)})) \\ & \quad \quad \quad \bar{n} \underset{\sim}{\sim}^{\Lambda_q(2)} \dots \bar{n} \underset{\sim}{\sim}^{\Lambda_q(\alpha_q)} S \cdot \xi(\Lambda_2(1), \dots, \Lambda_q(\alpha_q), X_{(1)}). \quad (8) \end{aligned}$$

It is easy to prove that $L = S \cdot \xi(\Lambda_2(1), \dots, \Lambda_q(\alpha_q), X_{(1)})$ is a ladder state for X with step b_1 and that each of the sequences of equations (6), (7) and (8) has indistinguishability degree no less than $n - 2$. Combining all these sequences, we obtain a new path

$$\mathfrak{p}: S_X \sim \dots \sim L$$

with $\deg \mathfrak{p} \geq n - 2$. □

Lemma 5.10. *Let $n \geq 2, X, Y \subseteq \bar{n}$, \mathcal{A} a WOR protocol with safe-consensus objects and S a state that is reachable in \mathcal{A} in some round $r \geq 0$. Assume also that b_j is a box representing a safe-consensus object invoked by some processes such that $b_j \in \mathbf{Inv}(L_1) = \mathbf{Inv}(L_2)$, where $L_1 = S \cdot \xi(C_1, \dots, C_u, X_{(j)})$ is a ladder state for X with step b_j and $L_2 = S \cdot \xi(C_1, \dots, C_u, Y_{(j)})$ is a ladder state for $(X - X_{(j)}) \cup Y_{(j)}$ with step b_j . Finally, suppose that if $b_j = \bar{n}$, $\text{scval}(b_j, L_1) = \text{scval}(b_j, L_2)$. Then L_1 and L_2 are connected in round $r + 1$ with a C-regular path of states \mathfrak{p} that satisfies the following properties:*

- i) *If $\text{scval}(b_j, L_1) = \text{scval}(b_j, L_2)$ then $\deg \mathfrak{p} \geq n - 2$.*
- ii) *If $\text{scval}(b_j, L_1) \neq \text{scval}(b_j, L_2)$ then $\deg \mathfrak{p} \geq n - |b_j|$ and $\bar{n} - b_j \in \text{iSets}(\mathfrak{p})$.*

Proof. Partition \bar{n} as the disjoint union $\bar{n} = X^- \cup (X \cap Y) \cup Y^- \cup W$, where

$$X^- = X - Y;$$

$$Y^- = Y - X;$$

$$W = \bar{n} - (X^- \cup (X \cap Y) \cup Y^-).$$

What we need to do to go from L_1 to L_2 is to “interchange” $X_{(j)}$ with $Y_{(j)}$. We first construct a sequence of connected states \mathfrak{p}_1 given by

$$\begin{aligned} S \cdot \xi(C_1, \dots, C_u, X_{(j)}, Y^- \cup W) \\ \quad \bar{n} \underset{\sim}{\sim}^{\Lambda_j(1)} S \cdot \xi(C_1, \dots, C_u, \Lambda_j(1), X_{(j)} - \Lambda_j(1), Y^- \cup W) \\ \quad \bar{n} \underset{\sim}{\sim}^{\Lambda_j(2)} S \cdot \xi(C_1, \dots, C_u, \Lambda_j(1), \Lambda_j(2), X_{(j)} - (\Lambda_j(1) \cup \Lambda_j(2)), Y^- \cup W) \\ \quad \bar{n} \underset{\sim}{\sim}^{\Lambda_j(3)} \dots \bar{n} \underset{\sim}{\sim}^{\Lambda_j(\alpha_j-1)} S \cdot \xi(C_1, \dots, C_u, \Lambda_j(1), \Lambda_j(2), \dots, \Lambda_j(\alpha_j), Y^- \cup W) \\ \quad \bar{n} \underset{\sim}{\sim}^{\Lambda_j(\alpha_j)} S \cdot \xi(C_1, \dots, C_u, \Lambda_j(1), \Lambda_j(2), \dots, \Lambda_j(\alpha_j-1), \Lambda_j(\alpha_j) \cup Y^- \cup W) \\ \quad \bar{n} \underset{\sim}{\sim}^{\Lambda_j(\alpha_j-1)} \dots \bar{n} \underset{\sim}{\sim}^{\Lambda_j(1)} S \cdot \xi(C_1, \dots, C_u, X_{(j)} \cup Y^- \cup W), \end{aligned}$$

where the following properties hold:

- $X_{(j)} = \bigcup_{i=1}^{\alpha_j} \Lambda_j(i)$ is a partition of $X_{(j)}$ such that $|\Lambda_j(l)| = 1$ for $l = 2, \dots, \alpha_j$;
- $|\Lambda_j(1)| = 2$ if $|X_{(j)}| > 1$ and $|\Lambda_j(1)| = |X_{(j)}|$ otherwise;
- \mathfrak{p}_1 is a C-regular sequence (Lemma 5.8) with $\deg \mathfrak{p}_1 \geq n - 2$;
- the safe-consensus value of every box b_i is the same in each state of \mathfrak{p}_1 . This can be achieved by a proper selection of elements of the set $\Lambda_j(1)$ and the Safe-Validity property of the safe-consensus task.

Now, since the following equalities hold:

$$\begin{aligned} X_{(j)} \cup Y^- &= (X \cap b_j) \cup Y^- \\ &= ((X^- \cup (X \cap Y)) \cap b_j) \cup Y^- \\ &= X_{(j)}^- \cup (X \cap Y \cap b_j) \cup Y^- \\ &= X_{(j)}^- \cup (X \cap Y \cap b_j) \cup (Y^- - Y_{(j)}^-) \cup Y_{(j)}^- \\ &= (X \cap Y \cap b_j) \cup Y_{(j)}^- \cup X_{(j)}^- \cup (Y^- - Y_{(j)}^-) \\ &= Y_{(j)} \cup X_{(j)}^- \cup (Y^- - Y_{(j)}^-), \end{aligned}$$

we can write the state $S \cdot \xi(C_1, \dots, C_u, X_{(j)} \cup Y^- \cup W)$ as

$$S \cdot \xi(C_1, \dots, C_u, Y_{(j)} \cup X_{(j)}^- \cup (Y^- - Y_{(j)}^-) \cup W).$$

We need to build a second path p_2 as follows:

$$\begin{aligned}
& S \cdot \xi(C_1, \dots, C_u, Y_{(j)} \cup X_{(j)}^- \cup (Y^- - Y_{(j)}^-) \cup W) \\
& \quad \stackrel{\bar{n}-U}{\sim} S \cdot \xi(C_1, \dots, C_u, \Omega_j(1), (Y_{(j)} - \Omega_j(1)) \cup X_{(j)}^- \cup (Y^- - Y_{(j)}^-) \cup W) \\
& \quad \quad \quad \bar{n}-\Omega_j(2) \quad \dots \quad \bar{n}-\Omega_j(\varepsilon_j-1) \\
& \quad S \cdot \xi(C_1, \dots, C_u, \Omega_j(1), \dots, \Omega_j(\varepsilon_j) \cup X_{(j)}^- \cup (Y^- - Y_{(j)}^-) \cup W) \\
& \quad \stackrel{\bar{n}-\Omega_j(\varepsilon_j)}{\sim} S \cdot \xi(C_1, \dots, C_u, \Omega_j(1), \dots, \Omega_j(\varepsilon_j), X_{(j)}^- \cup (Y^- - Y_{(j)}^-) \cup W) \\
& \quad \quad \quad \bar{n}-\Omega_j(\varepsilon_j-1) \\
& \quad S \cdot \xi(C_1, \dots, C_u, \Omega_j(1), \dots, \Omega_j(\varepsilon_j-1) \cup \Omega_j(\varepsilon_j), X_{(j)}^- \cup (Y^- - Y_{(j)}^-) \cup W) \\
& \quad \quad \quad \bar{n}-\Omega_j(\varepsilon_j-2) \quad \dots \quad \bar{n}-\Omega_j(1) \quad S \cdot \xi(C_1, \dots, C_u, Y_{(j)}, X_{(j)}^- \cup (Y^- - Y_{(j)}^-) \cup W). \quad (9)
\end{aligned}$$

Let L_2 be the last state of the previous sequence. The next assertions are true for the path p_2 :

- The sets $\Omega_j(i)$ and ε_j are defined for $Y_{(j)}$ and b_j in the same way as the $\Lambda_j(i)$ and α_j are defined for $X_{(j)}$ and b_j ;
- The sequence p_2 is C-regular (Lemma 5.8);
- The safe-consensus value of every box $c \neq b_j$ is the same in every element of $\text{States}(p_2)$;
- $\text{scval}(b_j, Q) = \text{scval}(b_j, P)$ for all $Q, P \in \text{States}(p_2) - \{R\}$, where R is such that

$$R = S \cdot \xi(C_1, \dots, C_u, Y_{(j)} \cup X_{(j)}^- \cup (Y^- - Y_{(j)}^-) \cup W);$$

- the set U is defined by

$$U = \begin{cases} b_j & \text{if } \text{scval}(b_j, L_1) \neq \text{scval}(b_j, L_2) \\ \Omega_j(1) & \text{otherwise;} \end{cases} \quad (10)$$

Notice that by the last assertion, we can deduce that $\deg p_2 \geq n - |b_j|$ and $\bar{n} - b_j \in \text{iSets}(p_2)$ if $\text{scval}(b_j, L_1) \neq \text{scval}(b_j, L_2)$ and $\deg p_2 \geq n - 2$ when $\text{scval}(b_j, L_1) = \text{scval}(b_j, L_2)$. Thus we can use p_1 and p_2 to obtain a C-regular sequence p which fulfils properties i)-ii) of the lemma and that concludes the proof. \square

Lemma 5.11. *Let $n \geq 2$, $X, Y \subseteq \bar{n}$, \mathcal{A} a WOR protocol with safe-consensus objects, S a state that is reachable in \mathcal{A} in some round $r \geq 0$ and b_j a box representing a safe-consensus object invoked by some processes in round $r+1$ such that $b_j \in \text{Inv}(Q_1) = \text{Inv}(Q_2)$, where $Q_1 = S \cdot \xi(X)$ and $Q_2 = S \cdot \xi(Y_{(j)} \cup (X - X_{(j)}))$. Assume also that if $b_j = \bar{n}$, $\text{scval}(b_j, Q_1) = \text{scval}(b_j, Q_2)$. Then the states Q_1 and Q_2 are connected in round $r+1$ with a C-regular path of states p that satisfies the following properties:*

- If $\text{scval}(b_j, Q_1) = \text{scval}(b_j, Q_2)$ then $\deg p \geq n - 2$.
- If $\text{scval}(b_j, Q_1) \neq \text{scval}(b_j, Q_2)$ then $\deg p \geq n - |b_j|$ and $\bar{n} - b_j \in \text{iSets}(p)$.

Proof. By Lemma 5.9, the state Q_1 can be connected with a state of the form $Q_{X(j)} = S \cdot \xi(B_1, \dots, B_s, X(j))$ with a C-regular path q_1 such that $\deg q_1 \geq n - 2$. Using Lemma 5.10, $Q_{X(j)}$ can be connected with $Q_{Y(j)} = S \cdot \xi(B_1, \dots, B_s, Y(j))$ by means of a C-regular sequence $q_2: Q_{X(j)} \sim \dots \sim Q_{Y(j)}$ such that q_2 satisfies properties i) and ii) of that Lemma. And we can apply Lemma 5.9 to connect $Q_{Y(j)}$ with Q_2 with the C-regular path q_3 which has indistinguishability degree no less than $n - 2$. Therefore the sequence of connected states built by first gluing together the sequences q_1 and q_2 , followed by q_3 , is a C-regular sequence q such that the requirements a)-b) are satisfied. \square

With the three previous lemmas at hand, we are almost ready to state and prove Theorem 5.12, only one more definition is necessary. Let Q_1, Q_2 be two reachable states in round r of an iterated protocol \mathcal{A} for n processes with safe-consensus objects. The set $\mathfrak{D}_{\mathcal{A}}^r(Q_1, Q_2)$ is defined as

$$\mathfrak{D}_{\mathcal{A}}^r(Q_1, Q_2) = \{b \in \Gamma_{\mathcal{A}}(n) \mid b \in \mathbf{Inv}(Q_1) \cap \mathbf{Inv}(Q_2) \text{ and } \text{scval}(b, Q_1) \neq \text{scval}(b, Q_2)\}.$$

In words, $\mathfrak{D}_{\mathcal{A}}^r(Q_1, Q_2)$ represents the safe-consensus shared objects that the same subset of processes invoked in both states Q_1 and Q_2 , such that the shared objects returned different output values in each state. If there is no confusion about which round number and protocol we refer to, we will write $\mathfrak{D}_{\mathcal{A}}^r(Q_1, Q_2)$ as $\mathfrak{D}(Q_1, Q_2)$.

Theorem 5.12. *Let $n \geq 2$ and $X, Y \subseteq \bar{n}$, \mathcal{A} a WOR protocol with safe-consensus objects, S a reachable state of \mathcal{A} in some round $r \geq 0$ and let $Q_1 = S \cdot \xi(X)$ and $Q_2 = S \cdot \xi(Y)$ be such that $\bar{n} \notin \mathfrak{D}(Q_1, Q_2)$. Then Q_1 and Q_2 are connected in round $r + 1$ with a C-regular path of states p such that*

(A) *If $\mathfrak{D}(Q_1, Q_2) = \emptyset$, then $\deg p \geq n - 2$.*

(B) *If the set $\mathfrak{D}(Q_1, Q_2)$ is not empty, then*

1. *$\deg p \geq \min\{n - |b|\}_{b \in \mathfrak{D}(Q_1, Q_2)}$;*

2. *for every $Z \in \text{iSets}(p)$ with $|Z| < n - 2$, there exists $b \in \mathfrak{D}(Q_1, Q_2)$ such that $Z = \bar{n} - b$.*

Proof. By Lemma 5.8, we have the following equation,

$$\mathfrak{D}(P_1, P_2) = \{b \in \Gamma_{\mathcal{A}}(n) \mid b \in \mathbf{Inv}_S \text{ and } \text{scval}(b, P_1) \neq \text{scval}(b, P_2)\},$$

where P_l is a one-round successor state of S and $\mathbf{Inv}_S = \mathbf{Inv}(P_l)$, $l = 1, 2$. Let $\mathbf{Inv}_S = \{b_1, \dots, b_q\}$. By Lemma 5.11, we can connect the state Q_1 with $R_1 = S \cdot \xi(Y_{(1)} \cup (X - X_{(1)}))$ using a C-regular path $p_1: Q_1 \sim \dots \sim R_1$ such that

(A₁) *If $b_1 \notin \mathfrak{D}(Q_1, R_1)$, then $\deg p_1 \geq n - 2$.*

(B₁) *If $b_1 \in \mathfrak{D}(Q_1, R_1)$, then $\deg p_1 \geq n - |b_1|$ and $\bar{n} - b_1 \in \text{iSets}(p_1)$.*

Assume there is a set $Z \in \text{iSets}(p_1)$ with size strictly less than $n - 2$. Then it must be true that $b_1 \in \mathfrak{D}(Q_1, R_1)$, because if $b_1 \notin \mathfrak{D}(Q_1, R_1)$, by (A₁), $|Z| \geq n - 2$ and this is impossible. Thus the conclusion of property (B₁) holds for p_1 , which means that $\bar{n} - b_1 \in \text{iSets}(p_1)$. Examining the proof⁴ of Lemma 5.11 we can convince ourselves that every $W \in \text{iSets}(p_1)$ such that $W \neq \bar{n} - b_1$ has cardinality at least $n - 2$, therefore, $Z = \bar{n} - b_1$.

⁴In the proof of Lemma 5.11, p_1 is build using three subpaths q_1, q_2 y q_3 . The paths q_1 and q_3 have indistinguishability degree at least $n - 2$ (Lemma 5.9). The path q_2 is build using Lemma 5.10 and we can check that every set $X \in \text{States}(q_2)$ satisfies $|X| \geq n - 2$, except at most, the set $\bar{n} - U$ in Equation (9), since U satisfies Equation (10).

Now, considering that⁵ $Y_{(2)} \cup ((Y_{(1)} \cup (X - X_{(1)})) - X_{(2)}) = Y_{(2)} \cup ((Y_{(1)} - X_{(2)}) \cup ((X - X_{(1)}) - X_{(2)})) = Y_{(1)} \cup Y_{(2)} \cup (X - (X_{(1)} \cup X_{(2)}))$, we can apply Lemma 5.11 to the states R_1 and $R_2 = S \cdot \xi(Y_{(1)} \cup Y_{(2)} \cup (X - (X_{(1)} \cup X_{(2)})))$ to find a C-regular sequence $\mathfrak{p}_2: R_1 \sim \dots \sim R_2$ such that \mathfrak{p}_2 and b_2 enjoy the same properties that \mathfrak{p}_1 and b_1 have. We can combine the paths \mathfrak{p}_1 and \mathfrak{p}_2 to obtain a C-regular sequence $\mathfrak{p}_{12}: Q_1 \sim \dots \sim R_2$ from Q_1 to R_2 satisfying the properties

(A₂) If $\{b_1, b_2\} \cap \mathfrak{D}(Q_1, R_2) = \emptyset$, then $\deg \mathfrak{p}_{12} \geq n - 2$.

(B₂) If $\{b_1, b_2\} \cap \mathfrak{D}(Q_1, R_2)$ is not empty, then

1. $\deg \mathfrak{p}_{12} \geq \min\{n - |b| \}_{b \in \{b_1, b_2\} \cap \mathfrak{D}(Q_1, R_2)}$;
2. for every $Z \in \text{iSets}(\mathfrak{p}_{12})$ with $|Z| < n - 2$, there exists $b \in \{b_1, b_2\} \cap \mathfrak{D}(Q_1, R_2)$ such that $Z = \bar{n} - b$.

We can repeat this process for all $s \in \{1, \dots, q\}$. In general, if $R_s = S \cdot \xi((\bigcup_i^s Y_{(i)}) \cup (X - (\bigcup_i^s X_{(i)})))$, we can construct a C-regular path

$$\mathfrak{p}_{1s}: Q_1 \sim \dots \sim R_s,$$

with the properties

(A_s) If $\{b_1, \dots, b_s\} \cap \mathfrak{D}(Q_1, R_s) = \emptyset$, then $\deg \mathfrak{p}_{1s} \geq n - 2$.

(B_s) If $\{b_1, \dots, b_s\} \cap \mathfrak{D}(Q_1, R_s)$ is not empty, then

1. $\deg \mathfrak{p}_{1s} \geq \min\{n - |b| \}_{b \in \{b_1, \dots, b_s\} \cap \mathfrak{D}(Q_1, R_s)}$;
2. for every $Z \in \text{iSets}(\mathfrak{p}_{1s})$ with $|Z| < n - 2$, there exists an unique $b \in \{b_1, \dots, b_s\} \cap \mathfrak{D}(Q_1, R_s)$ such that $Z = \bar{n} - b$.

As $R_q = S \cdot \xi((\bigcup_i^q Y_{(i)}) \cup (X - (\bigcup_i^q X_{(i)}))) = S \cdot \xi(Y) = Q_2$, the sequence \mathfrak{p}_{1q} is the desired C-regular path from Q_1 to Q_2 , fulfilling conditions (A) and (B) (because $\{b_1, \dots, b_q\} \cap \mathfrak{D}(Q_1, R_q) = \mathbf{Inv}_S \cap \mathfrak{D}(Q_1, Q_2) = \mathfrak{D}(Q_1, Q_2)$). The result follows. \square

5.5 The main structural results

In this section, we prove Lemma 5.16. To do this, we need one more structural result, Lemma 5.14 and our main result about Johnson graphs: Theorem 5.13. We first introduce some combinatorial definitions before stating this theorem. Remember from Section 3.5 that for $1 \leq m \leq n$, $V_{n,m} = \{c \subseteq \bar{n} \mid |c| = m\}$ and let $U \subseteq V_{n,m}$. We define the set $\zeta(U)$ as

$$\zeta(U) = \{c \cup d \mid c, d \in U \text{ and } |c \cap d| = m - 1\}.$$

Notice that each $f \in \zeta(U)$ has size $m + 1$, thus $\zeta(U) \subseteq V_{n,m+1}$. For any $v = 0, \dots, n - m$, the *iterated ζ -operator* ζ^v is given by

$$\zeta^v(U) = \begin{cases} U & \text{if } v = 0, \\ \zeta(\zeta^{v-1}(U)) & \text{otherwise.} \end{cases}$$

Since $U \subseteq V_{n,m}$, we can check that $\zeta^v(U) \subseteq V_{n,m+v}$.

⁵Remember that $Y_{(1)} - X_{(2)} = (Y \cap b_1) - (X \cap b_2) = Y \cap b_1 = Y_{(1)}$, since $b_1 \cap b_2 = \emptyset$.

The intuitive interpretation of U , ζ and the iterated ζ -operator from the point of view of WOR consensus protocols is the following: U represents a set of possible intermediate agreements between some subsets of processes of size m and ζ is some kind of method the processes use to extend the partial agreements specified by U to new agreements between sets of processes of size $m + 1$, but these new agreements can be made only if the required agreements of m processes exist inside U . The iterated ζ -operator is just a way to extend ζ to produce larger agreements, starting from agreements between sets of processes of size m . We are ready to state the combinatorial result needed to prove Lemma 5.16.

Theorem 5.13. *Let $U \subset V_{n,m}$ such that $|U| \leq n - m$. Then $\zeta^{n-m}(U) = \emptyset$.*

Notice that $\zeta^{n-m}(U) \subseteq V_{n,m+(n-m)} = V_{n,n} = \{\bar{n}\}$. Thus, the intuitive meaning of Theorem 5.13 (again, from the point of view of WOR consensus protocols) is that if there are not enough agreements ($\leq n - m$) of subsets of processes of size m , it is impossible to reach consensus among n processes, represented by the set \bar{n} . See Appendix A for more details and the full proof of Theorem 5.13.

With respect to the proofs of Lemmas 5.14 and 5.16, we need one more definition regarding paths of connected states of a WOR protocol and the boxes representing safe-consensus shared objects. For a given path \mathfrak{s} of connected states of an iterated protocol \mathcal{A} , consider the set

$$\beta_{\mathcal{A}}(\mathfrak{s}) = \{b \in \Gamma_{\mathcal{A}}(n) \mid (\exists X, Y \in \text{iSets}(\mathfrak{s}))(X \neq Y \text{ and } |X \cap b| = 1 \text{ and } |Y \cap b| = 1)\},$$

and if $m \in \bar{n}$, let $\beta_{\mathcal{A}}(\mathfrak{s}; m) = \beta_{\mathcal{A}}(\mathfrak{s}) \cap \Gamma_{\mathcal{A}}(n, m)$. Roughly speaking, the set $\beta_{\mathcal{A}}(\mathfrak{s})$ captures the safe-consensus shared objects the processes can invoke to decrease the degree of indistinguishability of paths composed of states which are successor states of the elements of $\text{States}(\mathfrak{s})$. In other words, if the path \mathfrak{s} is composed of reachable states in \mathcal{A} in round r , then the boxes (safe-consensus objects) in $\beta_{\mathcal{A}}(\mathfrak{s})$ can help the processes diminish the degree of indistinguishability of any possible path \mathfrak{q} such that each state in $\text{States}(\mathfrak{q})$ is a successor state of some member of $\text{States}(\mathfrak{s})$. If there is no confusion about which protocol we refer to, we write $\beta(\mathfrak{s})$ and $\beta(\mathfrak{s}; m)$ instead of $\beta_{\mathcal{A}}(\mathfrak{s})$ and $\beta_{\mathcal{A}}(\mathfrak{s}; m)$ respectively.

Lemma 5.14. *Let $n \geq 3$ and $1 \leq v \leq s \leq n - 2$ be fixed. Suppose that \mathcal{A} is a WOR protocol with safe-consensus objects and that there exists a sequence*

$$\mathfrak{s}: S_0 \overset{X_1}{\sim} \dots \overset{X_q}{\sim} S_q \quad (q \geq 1),$$

of connected states of round $r \geq 0$ such that

$$\Lambda_1 \text{deg } \mathfrak{s} \geq v.$$

$$\Lambda_2 \text{ For every } X_i \text{ with } v \leq |X_i| < s, \text{ there exists } b_i \in \Gamma_{\mathcal{A}}(n, n - |X_i|) \text{ such that } X_i = \bar{n} - b_i$$

$$\Lambda_3 \bar{n} \notin \beta(\mathfrak{s}).$$

Then in round $r + 1$ there exists a sequence

$$\mathfrak{q}: Q_0 \sim \dots \sim Q_u,$$

of connected successor states of all the S_j , such that the following statements hold:

$$\Psi_1 \text{ If } \beta(\mathfrak{s}; n - v + 1) = \emptyset, \text{ then } \text{deg } \mathfrak{q} \geq v.$$

$$\Psi_2 \text{ If } \beta(\mathfrak{s}; n - v + 1) \neq \emptyset, \text{ then } \text{deg } \mathfrak{q} \geq v - 1.$$

Ψ_3 For every $Z \in \text{iSets}(\mathfrak{q})$ with $|Z| = v - 1$, there exist $X, X' \in \text{iSets}(\mathfrak{s})$ and $b \in \beta(\mathfrak{s}; n - v + 1)$ such that $Z = \bar{n} - b = X \cap X'$ and $b = c_1 \cup c_2$, $c_k \in \Gamma_{\mathcal{A}}(n, n - v)$.

Ψ_4 For every $Z \in \text{iSets}(\mathfrak{q})$ with $v \leq |Z| < s$, there exists $b \in \Gamma_{\mathcal{A}}(n, n - |Z|)$ such that $Z = \bar{n} - b$.

Ψ_5 $\beta(\mathfrak{q}; n - l + 1) \subseteq \zeta(\beta(\mathfrak{s}; n - l))$ for $v \leq l < s$.

Proof. In order to find the path \mathfrak{q} that has the properties Ψ_1 - Ψ_5 , first we need to define a set of states of round $r + 1$, called $\Phi(\mathfrak{s})$, which we will use to construct the path \mathfrak{q} . The key ingredient of $\Phi(\mathfrak{s})$ is the safe-consensus values of the boxes used in each member of $\Phi(\mathfrak{s})$. Define the set of states $\Phi(\mathfrak{s})$ as

$$\Phi(\mathfrak{s}) = \{R \mid R = S \cdot \xi(X), (S, X) \in \text{States}(\mathfrak{s}) \times \text{iSets}(\mathfrak{s})\}.$$

Each element of $\Phi(\mathfrak{s})$ is a state in round $r + 1$ which is obtained when all the processes with ids in some set $X \in \text{iSets}(\mathfrak{s})$ execute concurrently the operations of \mathcal{A} , followed by all processes with ids in $\bar{n} - X$. The safe-consensus values of each box for the states of $\Phi(\mathfrak{s})$ in round $r + 1$ are defined by using the following rules: Let b be any box such that $b \notin \beta(\mathfrak{s})$.

- If $|X \cap b| \neq 1$ for every $X \in \text{iSets}(\mathfrak{s})$, then we choose any value j such that j is the safe-consensus value of b in every state $R \in \Phi(\mathfrak{s})$ with $b \in \mathbf{Inv}(R)$.
- If there exists exactly one set $X \in \text{iSets}(\mathfrak{s})$ such that $X \cap b = \{x\}$, then b has j_x as its safe-consensus value in every state $Q \in \Phi(\mathfrak{s})$ with $b \in \mathbf{Inv}(Q)$, where j_x is the value proposed by process p_x when invoking the safe-consensus object represented by b .

Now we establish rules to define the safe-consensus values of every element of the set $\beta(\mathfrak{s})$, using the order on the set $\text{iSets}(\mathfrak{s})$ induced by the path \mathfrak{s} , when we traverse \mathfrak{s} from S_0 to S_q . That is, $\text{iSets}(\mathfrak{s})$ is ordered as

$$X_1, \dots, X_q. \quad (11)$$

For each $b \in \beta(\mathfrak{s})$, let that $X_i, X_{i+z_1}, \dots, X_{i+z_k}$, ($1 \leq i < i+z_1 < i+z_2 < \dots < i+z_k \leq q; z_j > 0$ and $k \geq 1$) be the (ordered) subset of $\text{iSets}(\mathfrak{s})$ of all $X \in \text{iSets}(\mathfrak{s})$ with the property $|X \cap b| = 1$. Take the set X_i . If $x_i \in X_i \cap b$, then we make the value proposed by process p_{x_i} (when invoking the shared object represented by b) the safe-consensus value of b for all the elements of $\Phi(\mathfrak{s})$ of the form

$$P_j = S \cdot \xi(X_j), \quad 1 \leq j \leq i+z_1 - 1,$$

where $b \in \mathbf{Inv}(P_j)$. Next, in all states $R_u \in \Phi(\mathfrak{s})$ such that $R_u = S \cdot \xi(X_u)$ with $b \in \mathbf{Inv}(R_u)$ and $i+z_1 \leq u \leq i+z_2 - 1$, b has safe-consensus value equal to the input value of the process with id $x_{i+z_1} \in X_{i+z_1} \cap b$ when invoking the safe-consensus object represented by b . In general, in all states $T_v \in \Phi(\mathfrak{s})$ of the form

$$T_v = S \cdot \xi(X_v), \quad i+z_l \leq v \leq i+z_{l+1} - 1 \text{ and } 1 \leq l \leq k-1,$$

where $b \in \mathbf{Inv}(T_v)$, b has safe-consensus value equal to the input value of the process with id $x_{i+z_l} \in X_{i+z_l} \cap b$ feed to the safe-consensus object represented by b . Finally, in each state $L_w = S \cdot \xi(X_w) \in \Phi(\mathfrak{s})$ with $b \in \mathbf{Inv}(L_w)$ and $i+z_k \leq w \leq q$, b has safe-consensus value equal to the input value that the process with id $x_{i+z_k} \in X_{i+z_k} \cap b$ inputs to the safe-consensus shared object represented by b .

Using the Safe-Validity property of the safe-consensus task, it is an easy routine task to show that we can find states of \mathcal{A} in round $r + 1$ which have the form of the states given in $\Phi(\mathfrak{s})$ and with the desired safe-consensus values for every box.

We are ready to build the sequence q of the Lemma⁶. We use induction on $q \geq 1$. For the base case when $q = 1$, we have that $s: S_0 \stackrel{X_1}{\sim} S_1$, with $|X_1| \geq v$. Here we easily build the sequence $S_0 \cdot \xi(X_1) \stackrel{X_1}{\sim} S_1 \cdot \xi(X_1)$ which clearly satisfies properties Ψ_1 - Ψ_5 . Assume that for $1 \leq w < q$ we have a path

$$q': Q_0 \sim \dots \sim Q_l \quad (l \geq 1),$$

Satisfying conditions Ψ_1 - Ψ_5 and such that $Q_0 = S_0 \cdot \xi(X_1), Q_l = S_w \cdot \xi(X_w)$. We now connect the state Q_l with $Q = S_{w+1} \cdot \xi(X_{w+1})$. By Theorem 5.12, there is a C-regular sequence

$$v: Q_l \sim \dots \sim Q'$$

such that $Q' = S_w \cdot \xi(X_{w+1})$ and v, Q_l and Q' satisfy conditions (A)-(B) of that theorem. Clearly $\mathfrak{D}(Q_l, Q') \subseteq \beta(s)$, because the only boxes used by \mathcal{A} in the states Q_l and Q' with different safe-consensus value, are the boxes which intersect two different sets $X, X' \in \text{iSets}(s)$ in one element. Joining the sequence q' with v , followed by the small path $t: Q' \stackrel{X_{w+1}}{\sim} Q$ (such that $\text{deg } t \geq v$), we obtain a new sequence $q: Q_0 \sim \dots \sim Q$. We now need to show that q satisfies properties Ψ_1 - Ψ_5 .

Ψ_1 Notice that every box in $\beta(s)$ has size no bigger than $n - v + 1$. Suppose that $\beta(s; n - v + 1) = \emptyset$. In particular, this implies that $\mathfrak{D}(Q_l, Q') \cap \Gamma_{\mathcal{A}}(n, n - v + 1) = \emptyset$. If it happens that $\mathfrak{D}(Q_l, Q')$ is void, then as condition (A) of Theorem 5.12 holds for v , $\text{deg } v \geq v$. But if $\mathfrak{D}(Q_l, Q') \neq \emptyset$ we have that $|b| \leq n - v$ for all $b \in \mathfrak{D}(Q_l, Q')$, thus by part 1. of property (B) of Theorem 5.12,

$$\text{deg } v \geq \min\{n - |b|\}_{b \in \mathfrak{D}(Q_l, Q')} \geq v.$$

By the induction, hypothesis $\text{deg } q' \geq v$. It is also true that $\text{deg } t \geq v$, therefore $\text{deg } q \geq v$.

Ψ_2 If $\beta(s; n - v + 1) \neq \emptyset$, then either $\text{deg } q' \geq v - 1$ (by the induction hypothesis) or $\text{deg } v \geq v - 1$. This last assertion is true, because by (B) of Theorem 5.12, we have that $\text{deg } v \geq \min\{n - |b|\}_{b \in \mathfrak{D}(Q_l, Q')} \geq v - 1$. Thus, $\text{deg } q \geq v - 1$.

Ψ_3 We remark first that $\text{iSets}(q) = \text{iSets}(q') \cup \text{iSets}(v) \cup \text{iSets}(t)$. If we are given $Z \in \text{iSets}(q)$ such that $|Z| = v - 1$, then $Z \in \text{iSets}(q')$ or $Z \in \text{iSets}(v)$. When $Z \in \text{iSets}(q')$, we use our induction hypothesis to show that $Z = Y \cap Y' = \bar{n} - d$ for some $Y, Y' \in \text{iSets}(s)$ and $d \in \beta(s; n - v + 1)$ such that $d = d' \cup d''$, $d', d'' \in \Gamma_{\mathcal{A}}(n, n - v)$. On the other hand, if $Z \in \text{iSets}(v)$, it must be true that $\mathfrak{D}(Q_l, Q') \neq \emptyset$ (if not, then $\text{deg } v \geq n - 2$ by property (A) of Theorem 5.12 for v and this contradicts the size of Z). As $v - 1 < n - 2$, we can apply part 2 of condition (B) of Theorem 5.12 to deduce that $Z = \bar{n} - b$ for a unique $b \in \mathfrak{D}(Q_l, Q')$. Because $|Z| = v - 1$, it is true that $|b| = n - v + 1$. Now, $b \in \mathfrak{D}(Q_l, Q') \subseteq \beta(s)$, thus there exist $X, X' \in \text{iSets}(s)$ such that

$$|X \cap b| = 1 \text{ and } |X' \cap b| = 1 \tag{12}$$

Combining Equation (12) with the fact that the size of b is $n - v + 1$, we can check that $|X| = |X'| = v$ and $\bar{n} - b = X \cap X'$, that is,

$$Z = \bar{n} - b = X \cap X',$$

and finally, we apply Λ_2 of the sequence s to X, X' to find two unique boxes $c, c' \in \Gamma_{\mathcal{A}}(n, n - v)$ with $X = \bar{n} - c$ and $X' = \bar{n} - c'$, so that

$$\bar{n} - b = X \cap X' = (\bar{n} - c) \cap (\bar{n} - c') = \bar{n} - (c \cup c'),$$

then $b = c \cup c'$ and condition Ψ_3 is satisfied by q .

⁶Notice that the order given to $\Phi(s)$ in equation 11 is the precise order in which the states of this set will appear in the path q .

Ψ_4 The sequence q fulfils this property because of the induction hypothesis on q' , condition Λ_2 for s and (B) of Theorem 5.12 for v .

Ψ_5 Let $l \in \{v, \dots, s-1\}$. This property is satisfied by q if $\beta(q; n-l+1) = \emptyset$. Suppose that $c \in \beta(q; n-l+1)$, there exist $X, Y \in \text{iSets}(q)$ such that $|X \cap c| = |Y \cap c| = 1$. Then $|X| = |Y| = l$, so that we use property Ψ_3 (or Ψ_4) on X, Y to find two boxes $b_X, b_Y \in \beta(s; n-l)$ such that $X = \bar{n} - b_X$ and $Y = \bar{n} - b_Y$. Also, $X \cap Y = \bar{n} - c$, thus $\bar{n} - c = X \cap Y = (\bar{n} - b_X) \cap (\bar{n} - b_Y) = \bar{n} - (b_X \cup b_Y)$. Therefore $c = b_X \cup b_Y$ and this says that $c \in \zeta(\beta(s; n-l))$. Condition Ψ_5 is fulfilled by q .

We have shown by induction that we can build the path q from the sequence s , no matter how many states s has. This proves the Lemma. \square

The following corollary is a weaker version of Lemma 5.14, and it can be proven as a consequence of that result.

Corollary 5.15. *Let $n \geq 3$ and $1 \leq s \leq n-2$ be fixed. Suppose that \mathcal{A} is a WOR protocol with safe-consensus objects and there exists a sequence*

$$s: S_0 \stackrel{X_1}{\sim} \dots \stackrel{X_r}{\sim} S_q \quad (q \geq 1),$$

of connected states of round $r \geq 0$ such that $\deg s \geq s$ and $\bar{n} \notin \beta(s)$. Then in round $r+1$ there exists a sequence

$$q: Q_0 \stackrel{Z_1}{\sim} \dots \stackrel{Z_u}{\sim} Q_u,$$

such that the following statements hold:

Ψ_1 *If $\beta(s; n-s+1) = \emptyset$, then $\deg q \geq s$.*

Ψ_2 *If $\beta(s; n-s+1)$ is not empty, then $\deg q \geq s-1$.*

Ψ_3 *For every $Z \in \text{iSets}(q)$ with $|Z| = s-1$, there exist $X, X' \in \text{iSets}(s)$ and a unique $b \in \beta(s; n-s+1)$ such that $Z = \bar{n} - b = X \cap X'$.*

Ψ_5 $\beta(q; n-s+2) \subseteq \zeta(\beta(s; n-s+1))$.

We have gathered all the required elements to prove one of the key ingredient of the full proof of Theorem 5.7. Lemma 5.16 expresses formally the fact that if in a WOR consensus protocol, the processes cannot make enough agreements of size m ($v_{\mathcal{A}}(n, m) \leq n-m$) then they won't be able to decrease the degree of indistinguishability of paths of connected states of reachable states in every round $r \geq 1$ of the protocol.

Lemma 5.16. *Assume that $3 \leq m \leq n$. Suppose that \mathcal{A} is a WOR protocol with safe-consensus objects such that $v_{\mathcal{A}}(n, m) \leq n-m$. If S_r, Q_r are two reachable states in \mathcal{A} for some round $r \geq 0$, connected with a sequence $q: S_r \sim \dots \sim Q_r$ of connected states such that $\deg q \geq n-m+1$. Then for all $u \geq 0$, there exist successor states S_{r+u}, Q_{r+u} of S_r and Q_r respectively, in round $r+u$ of \mathcal{A} , such that S_{r+u} and Q_{r+u} are connected.*

Proof. Let \mathcal{A} be a protocol with the given hypothesis, set $q_0 = q$ and $m = n-s+1$. Because $3 \leq m \leq n$, $s \in \{1, \dots, n-2\}$. Using the sequence q_0 and applying Corollary 5.15, we build a path $q_1: S_{r+1} \sim \dots \sim Q_{r+1}$, connecting the successor states S_{r+1}, Q_{r+1} of S_r and Q_r respectively, such that

$\Psi_{1,1}$ *If $\beta(q_0; n-s+1) = \emptyset$, then $\deg q_1 > s-1$.*

$\Psi_{1,2}$ If $\beta(q_0; n-s+1)$ is not empty, then $\deg q_1 \geq s-1$.

$\Psi_{1,3}$ For every $Z \in \text{iSets}(q_1)$ with $|Z| = s-1$, there exist $X, X' \in \text{iSets}(q_0)$ and a unique $b \in \beta(q_0; n-s+1)$ such that $Z = \bar{n} - b = X \cap X'$.

$\Psi_{1,5}$ $\beta(q_1; n-s+2) \subseteq \zeta(\beta(q_0; n-s+1))$.

Starting from q_1 and using induction together with Lemma 5.14, we can prove that for each $u \in \{1, \dots, s-1\}$, there exist successor states S_{r+u}, Q_{r+u} of the states S_r and Q_r respectively, and a sequence

$$q_u: S_{r+u} \sim \dots \sim Q_{r+u},$$

satisfying the properties:

$\Psi_{u,1}$ If $\beta(q_{u-1}; n-s+u) = \emptyset$, then $\deg q_u > s-u$.

$\Psi_{u,2}$ If $\beta(q_{u-1}; n-s+u)$ is not empty, then $\deg q_u \geq s-u$.

$\Psi_{u,3}$ For each $Z \in \text{iSets}(q_u)$ with $|Z| = s-1$, there exist $X, X' \in \text{iSets}(q_{u-1})$ and a unique $b \in \beta(q_{u-1}; n-s+1)$ such that $Z = \bar{n} - b = X \cap X'$.

$\Psi_{u,4}$ For each $Z \in \text{iSets}(q_u)$ with $s-u \leq |Z| < s-1$, there exist $X, X' \in \text{iSets}(q_{u-1})$ and a unique $b \in \beta(q_{u-1}; n-|Z|)$ such that $Z = \bar{n} - b = X \cap X'$ and $b = c_1 \cup c_2, c_k \in \beta(q_{u-1}; n-|Z|-1)$.

$\Psi_{u,5}$ $\beta(q_u; n-l+1) \subseteq \zeta(\beta(q_{u-1}; n-l))$ for $s-u \leq l < s$.

When $u = s-1$, we obtain a sequence $q_{s-1}: S_{r+s-1} \sim \dots \sim Q_{r+s-1}$ that connects the states S_{r+s-1} and Q_{r+s-1} , such that

$\Psi_{s-1,1}$ If $\beta(q_{s-2}; n-1) = \emptyset$, then $\deg q_{s-1} > 1$.

$\Psi_{s-1,2}$ If $\beta(q_{s-2}; n-1)$ is not empty, then $\deg q_{s-1} \geq 1$.

$\Psi_{s-1,3}$ For each $Z \in \text{iSets}(q_{s-1})$ with $|Z| = s-1$, there exist $X, X' \in \text{iSets}(q_{s-2})$ and a unique $b \in \beta(q_{s-2}; n-s+1)$ such that $Z = \bar{n} - b = X \cap X'$.

$\Psi_{s-1,4}$ For any $Z \in \text{iSets}(q_{s-1})$ with $1 \leq |Z| < s-1$, there exist $X, X' \in \text{iSets}(q_{s-2})$ and a unique $b \in \beta(q_{s-2}; n-|Z|)$ such that $Z = \bar{n} - b = X \cap X'$ and $b = c_1 \cup c_2, c_k \in \beta(q_{s-2}; n-|Z|-1)$.

$\Psi_{s-1,5}$ $\beta(q_{s-1}; n-l+1) \subseteq \zeta(\beta(q_{s-2}; n-l))$ for $1 \leq l < s$.

Our final goal is to show that for all $v \geq s-1$, we can connect in each round $r+v$ of \mathcal{A} , successor states of S_r and Q_r . We first claim that for any $w = 0, \dots, s-1$ and $z \geq 0$,

$$\zeta^z(\beta(q_w; n-s+1)) \subseteq \zeta^z(\Gamma_{\mathcal{A}}(n, n-s+1)),$$

(this is true because ζ preserves \subseteq) and combining this fact with the properties $\Psi_{u,5}$ and induction, we can show that for $1 \leq l < s$

$$\beta(q_{s-1}; n-l+1) \subseteq \zeta^{s-l}(\beta(q_{l-1}; n-s+1)) \subseteq \zeta^{s-l}(\Gamma_{\mathcal{A}}(n, n-s+1)). \quad (13)$$

And because $|\Gamma_{\mathcal{A}}(n, n-s+1)| = v_{\mathcal{A}}(n, n-s+1) \leq s-1$ and $m = n-s+1$, we use Theorem 5.13 to check that $\zeta^{s-1}(\Gamma_{\mathcal{A}}(n, n-s+1)) = \emptyset$, implying that

$$\beta(q_{s-1}; n) = \emptyset.$$

With all this data, Lemma 5.14 and an easy inductive argument (starting at the base case $v = s-1$), we can find for all $v \geq s-1$, states S_{r+v}, Q_{r+v} of round $r+v$ of \mathcal{A} , which are successor states of S_r and Q_r respectively and connected with a sequence q_v such that

$$\Psi'_{v,1} \text{ deg } q_v \geq 1.$$

$$\Psi'_{v,2} \text{ For every } Z \in \text{iSets}(q_v) \text{ with } |Z| = s-1, \text{ there exist } X, X' \in \text{iSets}(q_{v-1}) \text{ and a unique } b \in \beta(q_{v-1}; n-s+1) \text{ such that } Z = \bar{n} - b = X \cap X'.$$

$$\Psi'_{v,3} \text{ For every } Z \in \text{iSets}(q_v) \text{ with } 1 \leq |Z| < s-1, \text{ there exist } X, X' \in \text{iSets}(q_{v-1}) \text{ and a unique } b \in \beta(q_{v-1}; n-|Z|) \text{ such that } Z = \bar{n} - b = X \cap X' \text{ and } b = c_1 \cup c_2, c_k \in \beta(q_{v-1}; n-|Z|-1).$$

$$\Psi'_{v,4} \beta(q_v; n-l+1) \subseteq \zeta^{s-l}(\Gamma_{\mathcal{A}}(n, n-s+1)) \text{ for } 1 \leq l < s.$$

It is precisely these four properties of the path q_v which allow us to find the path q_{v+1} , applying Lemma 5.14, such that q_{v+1} enjoys the same properties. Therefore, starting from round r , we can connect in all rounds of \mathcal{A} , successor states of S_r and Q_r . The Lemma is proven. \square

5.6 The case $v_{\mathcal{A}}(n, 2) \leq n-2$

In Section 5.5, we proved Lemma 5.16, a key result to prove Theorem 5.7, but that lemma does not cover the case $v_{\mathcal{A}}(n, 2) \leq n-2$. In this section we prove Lemma 5.19, which covers the case $v_{\mathcal{A}}(n, 2) \leq n-2$ and it is the last ingredient that we need to prove Theorem 5.7. This can be done easily using Lemma 5.18, a structural result concerning paths of connected states and the following combinatorial result.

Lemma 5.17. *Let $U \subset V_{n,2}$ such that $|U| \leq n-2$. Then there exists a partition $\bar{n} = A \cup B$ such that*

$$(\forall b \in U)(b \subseteq A \text{ or } b \subseteq B).$$

The proof of Lemma 5.17 can be found in Section A.3 of the Appendix. Lemma 5.17 describes the combinatorics of Lemma 5.19 for the case $m = 2$, just in the same way Theorem 5.13 does the same thing for Lemma 5.16. Intuitively, when $|U| \leq n-2$, there are not enough agreements between pairs of processes and this allow us to partition the set of processes Π into two sets

$$\Pi = A \cup B,$$

and this partition can be used to build sequences of connected states in every round of an executing WOR protocol (Lemmas 5.18 and 5.19). We now proceed to prove the required results.

Lemma 5.18. *Let \mathcal{A} be a WOR protocol with safe-consensus objects. Suppose there exists a partition $\bar{n} = A \cup B$ and a sequence*

$$p: S_0 \sim \dots \sim S_l \quad (l \geq 0)$$

of connected states in round $r \geq 0$ of \mathcal{A} , with the following properties

$$I) \text{iSets}(p) = \{A, B\};$$

II) $(\forall b \in \Gamma_{\mathcal{A}}(n, 2))(b \subseteq A \text{ or } b \subseteq B)$.

Then in round $r + 1$ of \mathcal{A} there exists a path

$$q: Q_0 \sim \dots \sim Q_s \quad (s \geq 1)$$

of connected states and the following properties hold:

- a) Each state Q_k is of the form $Q_k = S_j \cdot \xi(X)$, where $X = A$ or $X = B$;
- b) $i\text{Sets}(q) = \{A, B\}$.

Proof. The techniques needed to prove this result are similar to those used in the proof of Lemma 5.14. We first define the safe-consensus value of every box $b \in \Gamma_{\mathcal{A}}(n, 2)$, using property II) and the safe-Validity property of safe-consensus. After doing that, we apply induction on l to build the path q (of successor states of elements from $i\text{Sets}(p)$) satisfying a)-b). We omit the details. \square

Lemma 5.19. *Let $n \geq 2$. If \mathcal{A} is a WOR protocol for n processes using safe-consensus objects with $v_{\mathcal{A}}(n, 2) \leq n - 2$ and S is a reachable state in \mathcal{A} for some round $r \geq 0$, then there exists a partition of the set $\bar{n} = A \cup B$ such that for all $u \geq 0$, the states $S \cdot \xi^u(A)$ and $S \cdot \xi^u(B)$ are connected.*

Proof. This proof is analogous to the proof of Lemma 5.16. We use Lemma 5.17 to find the partition of \bar{n} and then we apply inductively Lemma 5.18. We omit the details. \square

5.7 The proof of Theorem 5.7

Here we give the proof of Theorem 5.7 for any $n \geq 2$, thus completing all the necessary proofs of the paper.

Proof of Theorem 5.7 Assume that there exists a protocol \mathcal{A} for consensus such that there is some m with $2 \leq m \leq n$ with $v_{\mathcal{A}}(n, m) \leq n - m$. Let O, U be the initial states in which all processes have as input values 0s and 1s respectively. We now find successor states of O and U in each round $r \geq 0$, which are connected. There are two cases:

Case $m = 2$. By Lemma 5.19, there exists a partition of $\bar{n} = A \cup B$ such that for any state S and any $r \geq 0$, $S \cdot \xi^r(A)$ and $S \cdot \xi^r(B)$ are connected. Let OU be the initial state in which all processes with ids in A have as input value 0s and all processes with ids in B have as input values 1s. Then for all $r \geq 0$ we have that

$$O \cdot \xi^r(A) \stackrel{A}{\sim} OU \cdot \xi^r(A) \quad \text{and} \quad OU \cdot \xi^r(B) \stackrel{B}{\sim} U \cdot \xi^r(B)$$

and by Lemma 5.19, the states $OU \cdot \xi^r(A)$ and $OU \cdot \xi^r(B)$ are connected. Thus, for any r -round partial execution of \mathcal{A} , we can connect the states $O^r = O \cdot \xi^r(A)$ and $U^r = U \cdot \xi^r(B)$.

Case $3 \leq m \leq n$. By Lemma 3.2, we know that any two initial states for consensus are connected, so that we can connect O and U with a sequence q of initial states of \mathcal{A} and it is not hard to check that $\text{deg } q \geq n - 1 \geq n - m + 1$. By Lemma 5.16, for each round $r \geq 0$ of \mathcal{A} , there exist successor states O^r, U^r of O and U respectively, such that O^r and U^r are connected.

In this way, we have connected successor states of O and U in each round of the protocol \mathcal{A} . Now, O is a 0-valent, initial state, which is connected to the initial state U , so that we can apply Lemma 3.3 to conclude that U is 0-valent. But this contradicts the fact that U is a 1-valent state, so we have reached a contradiction. Therefore $v_{\mathcal{A}}(n, m) > n - m$. \square

6 Conclusion

In this paper, we have introduced three extensions to the basic iterated model of distributed computing [16], using the safe-consensus task proposed by Yehuda, Gafni and Lieber in [4] and studied some of their properties and the solvability of the consensus task in each model. These extensions are very natural, in the sense that, for the set of new shared objects used by the processes (besides the snapshot objects), the protocols follow the conventions of the standard iterated model for the snapshot objects and the new shared objects: Each set of objects is arranged as an array and each object is used only once by each processes and each process can access at most one shared object. This gives the protocols of the extended models a well behaved structure and allows for an easier analysis of their executions, because of their inductive nature, even with the use of the new shared objects. We believe that iterated models extended with shared objects will play an important role in the development of the theory of models of distributed computing systems with shared objects, just in the same way the basic iterated model has played a fundamental role in the development of the theory of standard shared memory systems.

In the first iterated model that we investigated, the WRO iterated model, the processes first write to memory, then they snapshot it and after that, they invoke safe-consensus objects. We proved that in this model, the consensus task cannot be implemented. The impossibility proof uses simpler connectivity arguments that those used in the lower bound proof of the WOR iterated model. For the second iterated model, the OWR iterated model, processes first invoke safe-consensus objects, then they write to memory and then they snapshot the contents of the shared memory. We proved that this model is equivalent to the WRO iterated model for task solvability using simulations, thus we obtained as a corollary that consensus cannot be implemented in the OWR iterated model.

Finally, in the third model, the WOR iterated model, processes write to memory, invoke safe-consensus objects and they snapshot the shared memory. We first constructed a WOR protocol which can solve n -consensus with $\binom{n}{2}$ safe-consensus objects. To make this protocol more readable and simplify its analysis, we introduced a new group consensus task: The g -2coalitions-consensus task, which captures the difficulties of solving g processes consensus, even when almost all the processes know the proposed input values, except for two processes that only know one input value. This new task may be of independent interest in future research. We also proved that our WOR consensus protocol is sharp, by giving a $\binom{n}{2}$ lower bound on the number of safe-consensus objects necessary to implement n -consensus in the WOR iterated model with safe-consensus. This lower bound is the main result of this paper. To obtain this lower bound, we combined structural results about WOR protocols and combinatorial results applied to all the different subsets of processes that can invoke safe-consensus objects. At the very end, it is bivalency [2], but in order to be able to use bivalency, an intricate connectivity argument must be developed, in which we relate the way that the processes use the safe-consensus shared objects to solve consensus with subgraphs of the Johnson graphs. More specifically, our results suggest that for a given WOR protocol which solves n -consensus, the ability of the processes to make incremental partial agreements using safe-consensus objects to reach consensus, is encoded in the number of vertices and the connectivity of specific subgraphs of $J_{n,m}$ for $2 \leq m \leq n$. It is somehow surprising that Johnson graphs played such an important role in the proof of Theorem 5.7, these graphs and their properties are known to have applications in coding theory, specifically, Johnson graphs are closely related to *Johnson schemes* [37]. It is the first time that they appear in the scene of distributed systems. Our results might suggest some kind of connection between distributed systems and coding theory.

Also, in all our structural results of iterated protocols with safe-consensus, we see that connectivity of graphs appear again in the scene for the consensus task, this suggests that topology will play an important role to understand better the behaviour of protocols that use shared objects more powerful than read/write

shared memory registers. The proofs developed to obtain the lower bound say that the connectivity of the topological structures given by the shared objects used by the processes, can affect the connectivity of the topology of the protocol complex [24].

With respect to the relationship between the iterated models introduced in this paper and the standard model of distributed computing [1, 38] extended with safe-consensus objects used in [4] to implement consensus using safe-consensus objects, we can conclude the following. Our results for the WRO and the OWR iterated models say that these two models are not equivalent to the standard model with safe-consensus (for task solvability), as consensus can be implemented in the latter model [4], but consensus cannot be implemented in the WRO and OWR iterated models. Still, an open problem related to these two iterated models remains unsolved: The characterization of their exact computational power. Another closely related problem is: Are these two models more powerful than the standard shared memory model of distributed computing ?

On the other hand, the relationship between the standard model extended with safe-consensus and the WOR iterated model remains unknown. Are these two models equivalent? We conjecture that the answer is yes.

An interesting question for future work is the relation between safe consensus and abort objects. Hadzilacos and Toueg [39] introduced objects that behave like consensus objects except that any operation may abort without taking effect if it is concurrent with another operation.

References

- [1] Maurice Herlihy. Wait-free synchronization. *ACM Trans. Program. Lang. Syst.*, 13(1):124–149, January 1991.
- [2] Michael J. Fischer, Nancy A. Lynch, and Michael S. Paterson. Impossibility of distributed consensus with one faulty process. *J. ACM*, 32(2):374–382, 1985.
- [3] M. C. Loui and H. H. Abu-Amara. Memory requirements for agreement among unreliable asynchronous processes. *Parallel and Distributed Computing, Advances in Computing Research. F. P. Preparata ed., JAI Press, Greenwich, CT*, 4:163–183, 1987.
- [4] Yehuda Afek, Eli Gafni, and Opher Lieber. Tight group renaming on groups of size g is equivalent to g -consensus. In *Proceedings of the 23rd international conference on Distributed computing (DISC'09)*, volume 5805 of *LNCS*, pages 111–126, Berlin, Heidelberg, 2009. Springer-Verlag.
- [5] Rodolfo Conde and Sergio Rajsbaum. The complexity gap between consensus and safe-consensus. In Magnús M. Halldórsson, editor, *Structural Information and Communication Complexity*, volume 8576 of *Lecture Notes in Computer Science*, pages 68–82. Springer International Publishing, 2014.
- [6] Sergio Rajsbaum. Iterated shared memory models. In Alejandro López-Ortiz, editor, *LATIN 2010: Theoretical Informatics*, volume 6034 of *Lecture Notes in Computer Science*, pages 407–416. Springer Berlin / Heidelberg, 2010.
- [7] E. Borowsky, E. Gafni, N. Lynch, and S. Rajsbaum. The BG distributed simulation algorithm. *Distrib. Comput.*, 14(3):127–146, 2001.
- [8] Maurice Herlihy and Nir Shavit. The topological structure of asynchronous computability. *J. ACM*, 46(6):858–923, 1999.

- [9] Elizabeth Borowsky and Eli Gafni. Generalized FLP impossibility result for t-resilient asynchronous computations. In *STOC '93: Proceedings of the twenty-fifth annual ACM symposium on Theory of computing*, pages 91–100, New York, NY, USA, 1993. ACM.
- [10] Michael Saks and Fotios Zaharoglou. Wait-free k-set agreement is impossible: The topology of public knowledge. *SIAM J. Comput.*, 29(5):1449–1483, 2000.
- [11] Hagit Attiya, Amotz Bar-Noy, Danny Dolev, David Peleg, and Rudiger Reischuk. Renaming in an Asynchronous Environment. *Journal of the ACM*, July 1990.
- [12] Armando Castañeda, Maurice Herlihy, and Sergio Rajsbaum. An equivariance theorem with applications to renaming. In *Proceedings of the 10th Latin American International Conference on Theoretical Informatics, LATIN'12*, pages 133–144, Berlin, Heidelberg, 2012. Springer-Verlag.
- [13] Armando Castañeda and Sergio Rajsbaum. New combinatorial topology upper and lower bounds for renaming. In *Proceedings of the Twenty-seventh ACM Symposium on Principles of Distributed Computing, PODC '08*, pages 295–304, New York, NY, USA, 2008. ACM.
- [14] Armando Castañeda and Sergio Rajsbaum. New combinatorial topology bounds for renaming: The upper bound. *J. ACM*, 59(1):3:1–3:49, March 2012.
- [15] Armando Castañeda, Sergio Rajsbaum, and Michel Raynal. The renaming problem in shared memory systems: An introduction. *Computer Science Review*, 5(3):229–251, 2011.
- [16] Elizabeth Borowsky and Eli Gafni. A simple algorithmically reasoned characterization of wait-free computation (extended abstract). In *PODC '97: Proceedings of the sixteenth annual ACM symposium on Principles of distributed computing*, pages 189–198, New York, NY, USA, 1997. ACM.
- [17] Maurice Herlihy and Sergio Rajsbaum. The topology of shared-memory adversaries. In *PODC '10: Proceeding of the 29th ACM symposium on Principles of distributed computing*, pages 105–113, New York, NY, USA, 2010. ACM.
- [18] Maurice Herlihy and Sergio Rajsbaum. The topology of distributed adversaries. *Distributed Computing*, 26(3):173–192, 2013.
- [19] Sergio Rajsbaum, Michel Raynal, and Corentin Travers. An impossibility about failure detectors in the iterated immediate snapshot model. *Inf. Process. Lett.*, 108(3):160–164, 2008.
- [20] Sergio Rajsbaum, Michel Raynal, and Corentin Travers. The iterated restricted immediate snapshot model. In *COCOON '08: Proceedings of the 14th annual international conference on Computing and Combinatorics*, pages 487–497, Berlin, Heidelberg, 2008. Springer-Verlag.
- [21] Eli Gafni and Sergio Rajsbaum. Recursion in distributed computing. In Shlomi Dolev, Jorge Cobb, Michael Fischer, and Moti Yung, editors, *Stabilization, Safety, and Security of Distributed Systems*, volume 6366 of *Lecture Notes in Computer Science*, pages 362–376. Springer Berlin Heidelberg, 2010.
- [22] Eli Gafni, Sergio Rajsbaum, and Maurice Herlihy. Subconsensus tasks: Renaming is weaker than set agreement. In *Proceedings of the 20th international conference on Distributed computing (DISC'06)*, volume 4167 of *LNCS*, pages 329–338, Berlin, Heidelberg, 2006. Springer-Verlag.

- [23] Eli Gafni and Sergio Rajsbaum. Distributed programming with tasks. In Chenyang Lu, Toshimitsu Masuzawa, and Mohamed Mosbah, editors, *Principles of Distributed Systems*, volume 6490 of *Lecture Notes in Computer Science*, pages 205–218. Springer Berlin Heidelberg, 2010.
- [24] Maurice Herlihy, Dmitry Kozlov, and Sergio Rajsbaum. *Distributed Computing Through Combinatorial Topology*. Morgan Kaufmann, 2013.
- [25] Yehuda Afek, Iftah Gamzu, Irit Levy, Michael Merritt, and Gadi Taubenfeld. Group renaming. In *OPODIS '08: Proceedings of the 12th International Conference on Principles of Distributed Systems*, volume 5401 of *LNCS*, pages 58–72, Berlin, Heidelberg, 2008. Springer-Verlag.
- [26] Yoram Moses and Sergio Rajsbaum. A layered analysis of consensus. *SIAM J. Comput.*, 31(4):989–1021, 2002.
- [27] Hagit Attiya, Cynthia Dwork, Nancy Lynch, and Larry Stockmeyer. Bounds on the time to reach agreement in the presence of timing uncertainty. *J. ACM*, 41:122–152, January 1994.
- [28] Cynthia Dwork and Yoram Moses. Knowledge and common knowledge in a byzantine environment: Crash failures. *Information and Computation*, 88(2):156 – 186, 1990.
- [29] Rodolfo Conde and Sergio Rajsbaum. An introduction to the topological theory of distributed computing with safe-consensus. *Electronic Notes in Theoretical Computer Science*, 283(0):29 – 51, 2012. Proceedings of the workshop on Geometric and Topological Methods in Computer Science (GETCO).
- [30] Hagit Attiya and Sergio Rajsbaum. The combinatorial structure of wait-free solvable tasks. *SIAM J. Comput.*, 31(4):1286–1313, 2002.
- [31] Hagit Attiya and Jennifer Welch. *Distributed Computing: Fundamentals, Simulations and Advanced Topics*. John Wiley & Sons, 2004.
- [32] Yehuda Afek, Hagit Attiya, Danny Dolev, Eli Gafni, Michael Merritt, and Nir Shavit. Atomic snapshots of shared memory. *J. ACM*, 40(4):873–890, 1993.
- [33] Elizabeth Borowsky and Eli Gafni. Immediate atomic snapshots and fast renaming. In *PODC '93: Proceedings of the twelfth annual ACM symposium on Principles of distributed computing*, pages 41–51, New York, NY, USA, 1993. ACM.
- [34] Soma Chaudhuri. More choices allow more faults: set consensus problems in totally asynchronous systems. *Inf. Comput.*, 105:132–158, July 1993.
- [35] Eli Gafni. The extended BG-simulation and the characterization of t-resiliency. In *STOC '09: Proceedings of the 41st annual ACM symposium on Theory of computing*, pages 85–92, New York, NY, USA, 2009. ACM.
- [36] Armando Castañeda, Damien Imbs, Sergio Rajsbaum, and Michel Raynal. Renaming is weaker than set agreement but for perfect renaming: A map of sub-consensus tasks. In *Proceedings of the 10th Latin American International Conference on Theoretical Informatics, LATIN'12*, pages 145–156, Berlin, Heidelberg, 2012. Springer-Verlag.
- [37] Philippe Delsarte and Vladimir I. Levenshtein. Association schemes and coding theory. *IEEE Transactions on Information Theory*, 44(6):2477–2504, 1998.

- [38] Maurice P. Herlihy and Jeannette M. Wing. Linearizability: a correctness condition for concurrent objects. *ACM Trans. Program. Lang. Syst.*, 12(3):463–492, July 1990.
- [39] Vassos Hadzilacos and Sam Toueg. On deterministic abortable objects. In *Proceedings of the 2013 ACM Symposium on Principles of Distributed Computing*, PODC '13, pages 4–12, New York, NY, USA, 2013. Association for Computing Machinery.
- [40] B. Bollobás. *Modern Graph Theory: Béla Bollobás*. Graduate Texts in Mathematics Series. Springer, 1998.

A Appendix: Results on subgraphs of Johnson graphs

In this appendix, we prove Theorem 5.13 and Lemma 5.17, two results about subgraphs of Johnson graphs used to build the full proof of Theorem 5.7. The main result here is Theorem 5.13, which provides a new and interesting connection between Johnson graphs and iterated consensus protocols. We will be using some combinatorial facts of graph theory and finite sets.

A.1 Subgraphs of Johnson graphs

Our graph terminology is standard, see for example [40], all the graphs that we use are simple graphs. For any set A and $E \subseteq 2^A$, we denote the union of all the elements of every set in E as $\bigcup E$. For $1 \leq m \leq n$, the *Johnson graph* $J_{n,m}$ has as vertex set all subsets of \bar{n} of cardinality m , two vertices b_1, b_2 are adjacent if and only if $|b_1 \cap b_2| = m - 1$. Let $V_{n,m} = V(J_{n,m})$ and $U \subseteq V_{n,m}$, define the set $\zeta(U)$ as

$$\zeta(U) = \{c \cup d \mid c, d \in U \text{ and } |c \cap d| = m - 1\}. \quad (14)$$

Notice that each $f \in \zeta(U)$ has size $m + 1$ because, if $f = c \cup d$ for $c, d \in U$, then $|c| = |d| = m$ and it is known that $|c \cap d| = m - 1 \Leftrightarrow |c \cup d| = m + 1$. Thus $\zeta(U) \subseteq V_{n,m+1}$. For any $v = 0, \dots, n - m$, the *iterated ζ -operator* ζ^v is given by

$$\zeta^v(U) = \begin{cases} U & \text{if } v = 0, \\ \zeta(\zeta^{v-1}(U)) & \text{otherwise.} \end{cases} \quad (15)$$

As $U \subseteq V_{n,m}$, we can check that $\zeta^v(U) \subseteq V_{n,m+v}$. A simple, but useful property of the ζ -operator is that

$$\bigcup \zeta^v(U) \subseteq \bigcup U. \quad (16)$$

A.2 Preliminaries

We are ready to prove all the combinatorial results that we need.

Lemma A.1. *Let $U \subseteq V_{n,m}$ and $G = G[U]$. The following properties are satisfied.*

- (i) *If G is connected, then $|\bigcup U| \leq m - 1 + |U|$.*
- (ii) *If U_1, \dots, U_r are connected components of G , then $\zeta(\bigcup_{i=1}^r U_i) = \bigcup_{i=1}^r \zeta(U_i)$.*

Proof. (i) can be proven easily using induction on $|U|$ and (ii) is an easy consequence of the definitions, thus we omit the proof. \square

Lemma A.2. Let $U \subseteq V_{n,m}$ with $|U| \leq n - m$. If $G[U]$ is connected then $\bigcup U \neq \bar{n}$.

Proof. Suppose that with the given hypothesis $\bigcup U = \bar{n}$. As $G[U]$ is connected, we can use part (i) of Lemma A.1 to obtain the inequality $n \leq m + |U| - 1$. But this implies that $|U| \geq n - m + 1$ and this is a contradiction. Therefore $\bigcup U \neq \bar{n}$. \square

Lemma A.3. Let $U \subseteq V_{n,m}$ with $|U| > 1$ and $G = G[U]$ a connected subgraph of $J_{n,m}$. Then the graph $G' = G[\zeta(U)]$ is connected and $\bigcup \zeta(U) = \bigcup U$.

Proof. We show that G' is connected. If G contains only two vertices, then G' contains only one vertex and the result is immediate. So assume that $|U| > 2$ and take $b, c \in \zeta(U)$. We need to show that there is a path from b to c . We know that $b = b_1 \cup b_2$ and $c = c_1 \cup c_2$ with $b_i, c_i \in U$ for $i = 1, 2$. As G is connected, there is a path

$$v_1 = b_2, v_2, \dots, v_q = c_2,$$

and we use it to build the following path in G' ,

$$b = b_1 \cup v_1, v_1 \cup v_2, \dots, v_{q-1} \cup v_q, c = v_q \cup c_1,$$

thus b and c are connected in G' , so that it is a connected graph.

Now we prove that $\bigcup \zeta(U) = \bigcup U$. By Equation (16), $\bigcup \zeta(U) \subseteq \bigcup U$, so it only remains to prove the other inclusion. Let $x \in \bigcup U$, there is a vertex $b \in U$ such that $x \in b$ and as $|U| > 1$ and G is connected, there exists another vertex $c \in U$ such that b and c are adjacent in G . Then $b \cup c \in \zeta(U)$, thus

$$x \in b \subseteq b \cup c \subseteq \bigcup \zeta(U),$$

gather that, $\bigcup U \subseteq \bigcup \zeta(U)$ and the equality holds. This concludes the proof. \square

Lemma A.4. Let $U \subseteq V_{n,m}$, $G = G[U]$, $G' = G[\zeta(U)]$ and \mathcal{U} be the set of connected components of the graph G . Then the following conditions hold:

1. For any connected component V of G' , there exists a set $\mathcal{O} \subseteq \mathcal{U}$ such that $V = \zeta(\bigcup \mathcal{O}) = \bigcup_{Z \in \mathcal{O}} \zeta(Z)$.
2. If V, V' are two different connected components of G' and $\mathcal{O}, \mathcal{O}' \subseteq \mathcal{U}$ are the sets which fulfil property 1 for V and V' respectively, then $\mathcal{O} \cap \mathcal{O}' = \emptyset$.

Proof. Part 2 is clearly true, so we only need to prove part 1. Define the graph $\mathcal{H} = (V(\mathcal{H}), E(\mathcal{H}))$ as follows:

$$V(\mathcal{H}) = \mathcal{U};$$

Two vertices Z, Z' form an edge in $E(\mathcal{H})$ if and only if there exist $b, c \in Z$ and $d, e \in Z'$ such that

- $|b \cap c| = m - 1$ and $|d \cap e| = m - 1$
- $|(b \cup c) \cap (d \cup e)| \geq m$.

Roughly speaking, \mathcal{H} describes for two connected components Z, Z' of G , whether $\zeta(Z), \zeta(Z')$ lie in the same connected component of G' or not. Let V be a connected component of G' , if $b \in V$, then $b = b_1 \cup b_2$, where b_1, b_2 are in some connected component $Z_b \subseteq U$ of G . In \mathcal{H} , there exists a component \mathcal{O} such that $Z_b \in \mathcal{O}$. By Lemma A.3, $G[\zeta(Z_b)]$ is connected and $b \in \zeta(Z_b) \cap V$, so it is clear that $\zeta(Z_b) \subseteq V$. Suppose that $Z' \in \mathcal{O}$ with $Z' \neq Z_b$ and these components form an edge in \mathcal{H} . This means that $G[\zeta(Z_b)]$ and $G[\zeta(Z')]$

are joined by at least one edge in G' , thus every vertex of $\zeta(Z')$ is connected with every vertex of $\zeta(Z_b)$, and as $\zeta(Z_b) \subseteq V$, $\zeta(Z_b) \cup \zeta(Z') \subseteq V$. We can continue this process with every element of the set $\mathcal{O} - \{Z_b, Z'\}$ to show that

$$\zeta\left(\bigcup_{Z \in \mathcal{O}} Z\right) = \bigcup_{Z \in \mathcal{O}} \zeta(Z) \subseteq V.$$

(The first equality comes from part (ii) of Lemma A.1). We prove the other inclusion, if $V = \{b\}$, we are done. Otherwise, let $c \in V - \{b\}$, if $c \in \zeta(Z_b)$, then $c \in \zeta(\bigcup \mathcal{O})$. In case that $c \notin \zeta(Z_b)$, there must exist some connected component Z_c of G such that $c \in \zeta(Z_c)$ and $Z_c \neq Z_b$. In G' , we can find a path $b = v_1, \dots, v_q = c$ where $v_i \in V$ for $i = 1, \dots, q$. The set $\mathcal{Q} \subseteq \mathcal{U}$ defined as

$$\mathcal{Q} = \{X \in \mathcal{U} \mid (\exists j)(1 \leq j \leq q \text{ and } v_j \in \zeta(X))\},$$

can be seen to have the property that every pair of vertices $X, X' \in \mathcal{Q}$ are connected by a path in \mathcal{H} . Since $Z_b, Z_c \in \mathcal{Q}$, they are connected in \mathcal{H} and as $Z_b \in \mathcal{O}$, then $Z_c \in \mathcal{O}$, gather that, $c \in \zeta(\bigcup \mathcal{O})$. Therefore $V \subseteq \zeta(\bigcup \mathcal{O})$ and the equality $V = \bigcup_{Z \in \mathcal{O}} \zeta(Z)$ holds. This proves part 1 and finishes the proof. \square

Lemma A.5. *Let $U \subseteq V_{n,m}$ and \mathcal{U} be the set of connected components of $G[U]$. Then for all $s \in \{0, \dots, n - m\}$ and $G^s = G[\zeta^s(U)]$, the following conditions are satisfied.*

H1 *For every connected component V of the graph G^s , there exists a set $\mathcal{O} \subseteq \mathcal{U}$ such that*

$$|\bigcup V| \leq m - 1 + \sum_{Z \in \mathcal{O}} |Z|. \quad (17)$$

H2 *If V, V' are two different connected components of G^s and $\mathcal{O}, \mathcal{O}' \subseteq \mathcal{U}$ are the sets which make true the inequality given in (17) for V and V' respectively, then $\mathcal{O} \cap \mathcal{O}' = \emptyset$.*

Proof. We prove the lemma by using induction on s . For the base case $s = 0$, $G^0 = G[U]$, we use Lemma A.1 and we are done. Suppose that for $0 \leq s < n - m$, **H1** and **H2** are true. We prove the case $s + 1$, let W be a connected component of the graph G^{s+1} . By part 1 of Lemma A.4, we know that there is a unique set \mathcal{Q} of connected components of G^s such that

$$W = \bigcup_{Q \in \mathcal{Q}} \zeta(Q)$$

and because $\zeta(Q) \neq \emptyset$, $|Q| > 1$, so that by Lemma A.3, $\bigcup \zeta(Q) = \bigcup Q$ for all $Q \in \mathcal{Q}$, thus it is true that

$$\begin{aligned} \bigcup W &= \bigcup_{Q \in \mathcal{Q}} \left(\bigcup \zeta(Q) \right) \\ &= \bigcup_{Q \in \mathcal{Q}} \left(\bigcup Q \right) \\ &= \bigcup_{Q \in \mathcal{Q}} Q. \end{aligned}$$

By the induction hypothesis, $|\bigcup Q| \leq m - 1 + \sum_{Z \in \mathcal{O}_Q} |Z|$, where $\mathcal{O}_Q \subseteq \mathcal{U}$ for all $Q \in \mathcal{Q}$ and when $Q \neq R$, $\mathcal{O}_Q \cap \mathcal{O}_R = \emptyset$. With a simple induction on $|\mathcal{Q}|$, it is rather forward to show that

$$|\bigcup W| \leq m - 1 + \sum_{Z \in \mathcal{O}} |Z|,$$

where $\mathcal{O} = \bigcup_{Q \in \mathcal{Q}} \mathcal{O}_Q$, gather that, property **H1** is fulfilled. We now show that condition **H2** holds. If W' is another connected component of G^{s+1} , then applying the above procedure to W' yields $W' = \bigcup_{S \in \mathcal{S}} \zeta(S)$, $\bigcup W' = \bigcup_{S \in \mathcal{S}} (\bigcup S)$ and $|\bigcup W'| \leq m - 1 + \sum_{X \in \mathcal{O}'} |X|$, with $\mathcal{O}' = \bigcup_{S \in \mathcal{S}} \mathcal{O}_S$. By 2 of Lemma A.4, $\mathcal{Q} \cap \mathcal{S} = \emptyset$, so that if $Q \in \mathcal{Q}$ and $S \in \mathcal{S}$, then $Q \neq S$ and the induction hypothesis tells us that $\mathcal{O}_Q \cap \mathcal{O}_S = \emptyset$, thus

$$\begin{aligned} \mathcal{O} \cap \mathcal{O}' &= \left(\bigcup_{Q \in \mathcal{Q}} \mathcal{O}_Q \right) \cap \left(\bigcup_{S \in \mathcal{S}} \mathcal{O}_S \right) \\ &= \bigcup_{(Q,S) \in \mathcal{Q} \times \mathcal{S}} (\mathcal{O}_Q \cap \mathcal{O}_S) \\ &= \emptyset, \end{aligned}$$

and property **H2** is satisfied, so that by induction we obtain the result. \square

A.3 Proofs of Theorem 5.13 and Lemma 5.17

Using all the results that we have developed in this appendix, we can now prove Theorem 5.13, (the main result of the combinatorial part of the proof of Theorem 5.7) and Lemma 5.17, which is used to prove Lemma 5.19.

Proof of Theorem 5.13. For a contradiction, suppose that $\zeta^{n-m}(U) \neq \emptyset$, then $G[\zeta^{n-m}(U)]$ is the graph $J_{n,n}$ and contains the unique connected component $C = \{\bar{n}\}$, thus by Lemma A.5, for some set \mathcal{O} of connected components of $G[U]$,

$$n = |\bigcup C| \leq m - 1 + \sum_{Z \in \mathcal{O}} |Z| \leq m - 1 + |U|,$$

and we conclude that $|U| \geq n - m + 1$, a contradiction. So that $\zeta^{n-m}(U) \neq \emptyset$ is impossible. Therefore $\zeta^{n-m}(U)$ has no elements. \square

The proof of Lemma 5.17 uses properties of subgraphs of $J_{n,2}$ and it is far easier to obtain than the proof of Theorem 5.13.

Proof of Lemma 5.17. If $\bigcup U \neq \bar{n}$, then setting $A = \bar{n} - \{i\}$ and $B = \{i\}$ where $i \notin \bigcup U$ we are done. Otherwise, by Lemma A.2, the induced subgraph $G = G[U]$ of $J_{n,2}$ is disconnected. There exists a partition V_1, V_2 of $V(G) = U$ with the property that there is no edge of G from any vertex of V_1 to any vertex of V_2 . Let

$$A = \bigcup V_1 \quad \text{and} \quad B = \bigcup V_2.$$

It is easy to show that $\bar{n} = A \cup B$ is the partition of \bar{n} that we need. \square