

# Design and Performance of the Data Acquisition System for the NA61/SHINE Experiment at CERN<sup>☆</sup>

András László<sup>a,\*</sup>, Ervin Dénes<sup>a,1</sup>, Zoltán Fodor<sup>a</sup>, Tivadar Kiss<sup>a</sup>, Stuart Kleinfelder<sup>b</sup>, Csaba Soós<sup>c</sup>, Dariusz Tefelski<sup>d</sup>, Tamás Tölyhi<sup>a</sup>, György Vesztergombi<sup>a</sup>, Oskar Wyszynski<sup>c,e</sup>

<sup>a</sup>Wigner Research Centre for Physics of the Hungarian Academy of Sciences, P.O.Box 49 H-1525 Budapest, Hungary

<sup>b</sup>University of California, Irvine, CA 92697-2625, USA

<sup>c</sup>CERN, CH-1211 Geneva 23, Switzerland

<sup>d</sup>Faculty of Physics, Warsaw University of Technology, Koszykowa 75, 00-662 Warsaw, Poland

<sup>e</sup>Faculty of Physics, Dep. of Astro. and Appl. Comp. Sci. of the Jagiellonian University, Stanisława Łojasiewicza 11, 30-348 Kraków, Poland

## Abstract

This paper describes the hardware, firmware and software systems used in data acquisition for the NA61/SHINE experiment at the CERN SPS accelerator. Special emphasis is given to the design parameters of the readout electronics for the 40 m<sup>3</sup> volume Time Projection Chamber detectors, as these give the largest contribution to event data among all the subdetectors: events consisting of 8 bit ADC values from 256 time slices of 200 k electronic channels are to be read out with ~100 Hz rate. The data acquisition system is organized in “push-data mode”, i.e. local systems transmit data asynchronously. Techniques of solving subevent synchronization are also discussed.

**Keywords:** DAQ, readout, TPC, NA61, SHINE, SPS, CERN, DDL, RORC

**PACS:** 07.05.Hd

## 1. Introduction

NA61/SHINE is a large acceptance fixed target hadron spectrometer experiment at the SPS accelerator at CERN [1, 2, 3, 4, 5]. The main tracking system, i.e. the bending magnets and the five TPC detectors are inherited from the former experiment NA49 [6]. The physics program of NA61/SHINE is quite complex and covers the search for the critical point of strongly interacting matter, study the onset of deconfinement, the quantification of medium effects in strongly interacting matter, furthermore the measurement of hadron production spectra in hadron-nucleus collisions for cosmic ray and neutrino physics applications. These studies are

carried out using the SPS beamline which is able to provide hadron beams in the 10-350 GeV/c, and ion beams in the 10-160 GeV/c/nucleon beam momentum range. The hadron beams are produced by the 400 GeV/c proton beam of the SPS accelerator hitting a beryllium production target and are tagged with their particle type using a differential Čerenkov detector trigger signal. Ion beams are either direct beams from SPS whenever compatible with the accelerator schedule, or are fragmented from a lead beam of the SPS using a beryllium fragmentation target with subsequent element tagging using a threshold Čerenkov detector or via scintillator response amplitude. The beam rate reaching the detector is up to 100 kHz, being the safety limit, out of which about 5 to 100% are the tagged useful beam particles with the selected type, depending on the actually used configuration. This beam hits a fixed target which is either liquid hydrogen or solid state material, depending on the reaction to be studied. The thickness of the target is adjusted in such a way that the collision probability of the selected beam particle type with the target material is around 0.1-3% in order to limit the contribution of secondary collisions within the target material. This setting provides ~1-3 kHz collision event rate of the right type

<sup>☆</sup>This paper is dedicated to the memory of our colleague, Dr. Ervin Dénes, coauthor of this paper, deceased in June 2015.

\*Corresponding author.

Email addresses: laszlo.andras@wigner.mta.hu (András László), fodor.zoltan@wigner.mta.hu (Zoltán Fodor), kiss.tivadar@wigner.mta.hu (Tivadar Kiss), stuartk@uci.edu (Stuart Kleinfelder), csaba.soos@cern.ch (Csaba Soós), dariusz.tefelski@cern.ch (Dariusz Tefelski), tolyhi.tamas@wigner.mta.hu (Tamás Tölyhi), vezstergombi.gyorgy@wigner.mta.hu (György Vesztergombi), oskar.wyszynski@cern.ch (Oskar Wyszynski)

<sup>1</sup>Deceased.

to be potentially recorded by the spectrometer downstream of the target.

The outline of the experimental setup is shown in Fig. 1. The ultrarelativistic particles produced in the collision within the target enter into the strong,  $\sim 0.1$ - $1.5$  Tesla, field of two superconducting bending magnets where the trajectories are deflected according to their momentum to charge ratio. The bending power of the magnet system is up to 9 Tm. Within and downstream of the bending magnets, five large volume TPC (Time Projection Chamber) detectors record the charged particle trajectories in a  $40\text{ m}^3$  tracking volume. A set of ToF (Time of Flight) detectors aid the particle identification. The most downstream detector of the experiment is the PSD (Projectile Spectator Detector), a calorimeter used to measure the energy fraction of the piece of projectile nucleus which did not take part in particle production, providing a geometric measure of collision centrality.

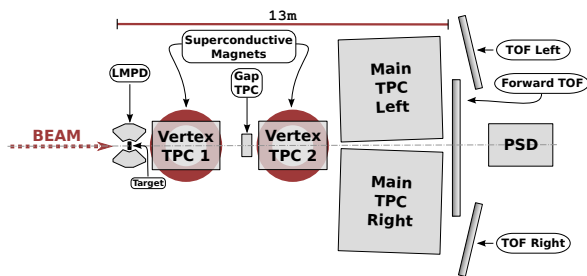

Figure 1: The setup of the NA61/SHINE detector. A set of trigger and beam counters are placed on the beamline, followed by the fixed target. A large acceptance magnetic spectrometer setup with  $40\text{ m}^3$  tracking volume is placed downstream of the target. The spectrometer setup consists of two large superconducting magnets and TPC (Time Projection Chamber) volumes. The setting is completed by a set of ToF (Time-of-Flight detectors) along with a calorimeter in the beamline, called PSD (Projectile Spectator Detector). In some of the runs the target is surrounded by a special detector, called LMPD (Low Momentum Particle Detector) [7], which is a small TPC chamber using the same readout as the large ones.

Upon the start of the NA61/SHINE program, several new detectors were added to the original NA49 tracking setup. In addition, the available readout rate not greater than  $\sim 10$  Hz in NA49 was insufficient for fully exploiting the available beam rates, and was also insufficient for completing the data taking schedule in a timely manner with the available 3-5 month of beamtime per year. Therefore a decision was made to design and produce a new readout system for NA61/SHINE in order to be able to record events at a rate  $\sim 100$  Hz, along with incorporating new detectors into the readout chain. In this upgrade project the most elaborate part was a new solution for the TPC readout, as this detector component

gives the largest contribution to the raw data. Therefore, this paper gives a special emphasis on the design requirements and description of the TPC readout part of the NA61 DAQ (Data Acquisition) system.

The paper is organized as follows. Section 2 summarizes the requirements on the new TPC electronics as a main motivation. Section 3 describes the new TPC electronics, their firmware and working principle. Section 4 describes the integration of further subdetectors into the readout chain. Section 5 summarizes the signal and data flow lines within the experimental setup. Section 6 describes the solutions for guaranteeing the event synchronization in the parallel data channels. Section 7 describes the online software, mainly the Central DAQ. Section 8 outlines the structure of the raw data files written by Central DAQ. Section 9 summarizes the observed performance. Section 10 concludes the paper.

## 2. Requirements on the TPC readout electronics

The  $40\text{ m}^3$  TPC chamber system produces the largest and most complicated subevent data of the experiment: for each triggered event the charge deposit on each of the 182784 readout pads need to be acquired throughout the  $51.2\text{ }\mu\text{sec}$  drift time in 256 or 512 samples, where the charge deposit is measured in 1 Byte ADC counts. This means 50 or 100 MByte per event in the 256 or 512 time sampling mode, respectively. In normal data taking, the 256 timebin mode is used, the 512 timebin mode is needed only during short and rare periods of gain calibration runs with radioactive Krypton gas in the TPC volumes. During normal beam data taking 50 MByte per event needs to be transported at a  $\sim 100$  Hz event rate, which would result in  $\sim 5$  GByte/sec data rate. However, the TPC detector data is zero dominated, since detection signal in the TPC volume only appears where particle trajectories traverse it. Therefore, it is evident that some kind of data compression method can and should be applied.

The original NA49 FEE (Front-End Electronics) cards of the TPC chambers [8, 9] provided a minimal dead time of 11.7 msec when read out. This already allows 86 Hz readout rate without modification of the 5712 pieces of FEE cards. A trade-off between the needed readout rate and the development time and costs motivated the re-usage of the NA49 FEE cards in the new system without modification, and the redesign of the readout electronics upstream of them. The electronic units reading out the FEE cards are called MotherBoards. They perform the steering of the readout process of the FEEs, the data compression before transfer, and subsequent serial transmission of the processed

FEE data. Because of geometrical and data density constraints, the MotherBoards were designed to read out up to 24 FEE cards, and therefore 248 MotherBoards were used in the complete system.

Due to the extended size of the full experimental setup, event data need to be transmitted to large distances, about 50 m, from the detectors to the location of the Central DAQ in the control room. This means a high risk for accidental introduction of ground loops in the system, and therefore galvanically decoupled transmission lines were needed. Our choice fell to the relatively cheap and well understood large bandwidth DDL (Detector Data Link) system [10, 11] for long range optical data transfer, also used in the ALICE experiment working at the LHC accelerator at CERN.

In order to minimize the number of optical links toward Central DAQ, an intermediate serialization stage was needed in between the MotherBoards and the Central DAQ. These units were called the ConcentratorBoxes and were designed to serialize data of up to 32 MotherBoards onto a DDL line. Short distance data transfer between the MotherBoards and the ConcentratorBoxes used relatively inexpensive LVDS (Low Voltage Differential Signal) connections. These connections, being differential, are noise tolerant and although they do not provide galvanic isolation, can work with up to  $\pm 1$  V common mode mismatch between the transmitter and the receiver side.

### 3. The TPC readout electronics

Motivated by the requirements discussed in Sec. 2, the NA61 TPC readout system [12] has four main components as shown in Fig. 2.

The main parts of the assembly are:

1. Front-End Electronics [8]: these cards perform the analog sampling of TPC pad charges, the analog storage of these and subsequent digitalization. Upon trigger arrival, one FEE card samples the preamplified and shaped pad charges over  $51.2 \mu\text{sec}$  time duration in 256 or 512 timeslices using an SCA (Switched Capacitor Array) [9]. The pertinent sampling clock is derived from a centrally generated 25 MHz oscillator in order to avoid phase ambiguity. Following the sampling period the, stored charges of each timeslice are digitized to 9 bits using Wilkinson ADCs. One FEE can handle 32 TPC detection pads. Due to historical reasons, each FEE is built up of two equivalent halves each handling 16 pads. The FEE cards are controlled and read out via a 50 line flat cable by a MotherBoard.

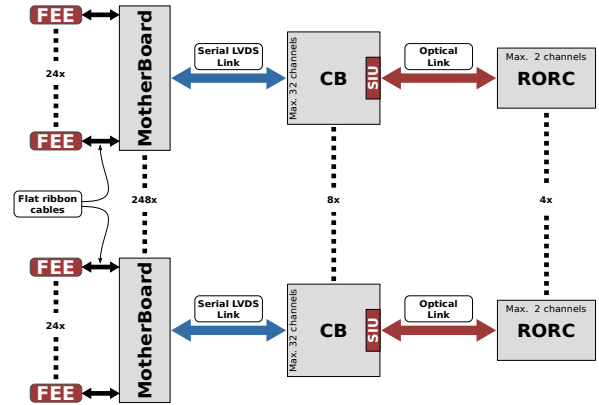

Figure 2: Block diagram of the NA61 TPC readout system. Up to 24 FEE cards are accessed by a processing MotherBoard using flat cable connection, then up to 32 MotherBoards transmit their data to a ConcentratorBox using LVDS connection, finally up to 10 ConcentratorBoxes forward the data to the Central DAQ PC using DDL optical line.

2. MotherBoards [12]: these organize the readout of the FEE cards and build a subevent data structure. They also perform pedestal subtraction, noise suppression, bit truncation and zero compression<sup>2</sup>. A MotherBoard has 24 input ports which are capable of reading out FEEs in parallel. For the 24 FEE cards two different cabling topologies are possible: one FEE card on each port ( $24 \times 1$  cabling), and 2 FEE cards connected in daisy chain by a flat cable to 12 ports of a MotherBoard ( $12 \times 2$  cabling). After reading out the FEE cards, the ADC values are pedestal subtracted, and any residual values smaller than a typical threshold of 6 ADC ( $\sim 2\sigma$  of the noise level) are substituted with zero values in a noise suppression process. These pedestal subtracted and noise suppressed ADC values are then truncated to 8 bits, are ordered according to natural detector geometry, and are subsequently serialized into a data stream. This data stream is then zero compressed, i.e. in case of zero ADCs only one zero and the number of consecutive zeros (up to 255) are transmitted in the stream. The serialized data of the FEEs are then sent by the MotherBoard onto an 50 Mbit/sec effective bandwidth LVDS connection, its transmission medium being a maximum 15 m long STP (Shielded Twisted Pair) cable. The LVDS connection reaches the next stage, the ConcentratorBoxes.

<sup>2</sup>A possibility for using Huffman compression is also foreseen, but it is not yet implemented, as the compression rate of simple zero compression proved to be sufficient for present data taking settings.

3. ConcentratorBoxes [12]: these are standalone serializer/deserializer boxes with 32 bidirectional LVDS inputs/outputs. A maximum of 32 MotherBoards can be connected to one ConcentratorBox. During the readout, the ConcentratorBox serializes the incoming data streams onto a single 32 bit wide data stream. Then the 32 bit data is transmitted to the DAQ server PC through DDL connection. In the other directions, the ConcentratorBox receives commands, pedestal table and other data from the DAQ PC addressed to the MotherBoards. The ConcentratorBox routes these data to the selected MotherBoard.
4. DDL [10, 11]: the DDL links are high-speed, serial optical links with parallel interfaces developed for the ALICE experiment. A link consists of a SIU (Source Interface Unit) card, a PCI-X or PCI-Express RORC (Readout Receiver Card) and a maximum 200 m length duplex optical cable with LC connectors. The DDL transfers the acquired detector data, data blocks or status info to the Central DAQ computer, and using a backward channel can load data blocks or commands from the Central DAQ system to the lower level systems. The bandwidth is guaranteed to be a minimum of 200 MByte/sec in both directions.

The MotherBoard has four different working modes: command processing mode, data block uploading or downloading mode, data collecting mode, pedestal collecting mode. In case of data collecting or pedestal collecting mode, upon receiving a “Start Data Taking” command the MotherBoard waits for the trigger signals. The workflow of the data acquisition is organized as follows. A common external clock (TPC CLK) is distributed to the MotherBoards in order to synchronize the readout system. The acquisition starts when a common external trigger is received. The TPC CLK along with the trigger are distributed via ECL lines. Receiving the trigger the MotherBoards force the FEE cards to start sampling the analog charges deposited on the TPC pads after amplification and shaping. Upon finishing, the MotherBoards issue digitization command and read out the raw amplitude ADC data produced on the FEE cards. The digitalization and ADC readout are made in timeslice order (Fig. 3):

1. digitalization of 32 channels in parallel,
2. readout of the 32 channels in channel order for all the FEE-s simultaneously,
3. the above steps are repeated for each timeslice.

The readout time slightly depends on which of the 24×1 or 12×2 cabling topologies are used for the connection

of the FEE cards to the MotherBoard, as in the latter case the two FEE card on the same flat cable is read out in an alternating order, causing a slight overhead. The maximum possible speed using 256 timeslices is around 90 events per second, limitation due to the FEE cards architecture. The control signals necessary for the FEE readout are all produced by the MotherBoard.

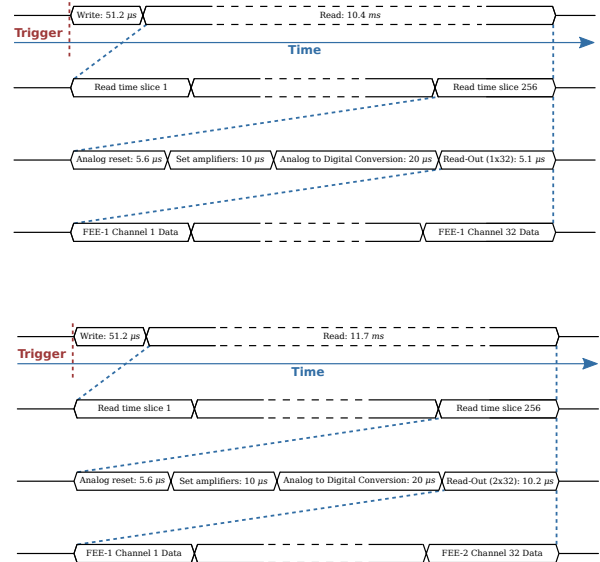

Figure 3: Time diagram of readout process of an FEE card in 24×1 (top panel) and 12×2 (bottom panel) cabling mode. The readout is done in the timeslice order, i.e. for each timeslice the charges on the 1×32 channels of 1 FEE card or 2×32 channels of 2 FEE card is digitized, and then they are read out in channel order. The magnified time regions are indicated by the dashed lines.

The schematic block diagram of a MotherBoard hardware architecture, based on FPGA technology for maintaining good development flexibility, is seen in Fig. 4. Each MotherBoard is equipped with 24 flat cable connectors for the 24 FEE cards. The FEE cards are read out in parallel, and their data are temporarily stored in the FPGA. The MotherBoard automatically multiplexes the 24 input data stream in a single serial output data stream. Before sending the data, the MotherBoard arranges them in padrow order and performs zero compression, reducing the amount of data. For the output data, sent on the LVDS lines to the ConcentratorBox, a simple, reliable bidirectional link protocol has been developed. The pedestal table and the noise suppression threshold can be downloaded to the MotherBoard through the same serial link. Some parameters important for the readout, such as the TPC and MotherBoard location identifiers, or the cabling topology of 24×1 or 12×2 can be preset using jumpers.

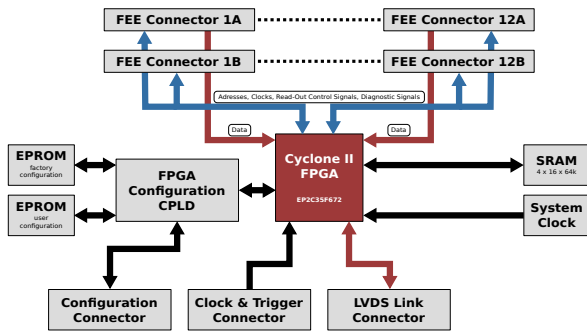

Figure 4: Schematic block diagram of a MotherBoard hardware architecture.

The simplified firmware block diagram of the MotherBoard firmware is shown in Fig. 5.

- The “FEE Write and Read-Out Controller” unit controls the read out of the FEE cards and subtracts the pedestal values.
- The “Pedestal Write and Read-Out Controller” module has several functions. During data taking it reads the pedestal value from the external SRAM memory belonging to the current data. In pedestal collecting mode it saves the value in the external SRAM and transmits all pedestals toward the ConcentratorBox when the collecting has finished. Using the received pedestal, i.e. zero-signal events, the DAQ computer calculates the table of average pedestals and sends it back to the MotherBoard, saving it in its external SRAM memory. This module has an additional function which is activated in the rare cases when the output FIFO of the MotherBoard becomes full. In that case the incoming data are saved in the upper half of the external SRAM and sent to the “Zero Compression” unit only at the end of data reading.
- The “Pad-Row Builder” unit sorts the data according to their padrow number.
- The “Zero Compression” module compresses the incoming data and writes them into the output FIFO.
- The “Command reply, Event Builder and Serialiser” unit continuously takes the data from the output FIFO and converts them into serial data. Additionally, this module sends status information. Also this module is responsible for the uploading of data blocks, such as pedestals from the external SRAM or the firmware file from configuration

EEPROM toward the ConcentratorBox, whenever verification reading is requested. In order to distinguish normal data bytes and status data bytes, the module frames the 8 bit wide data stream to 11 bits, the leading 2 bit encoding the type of the data byte, whereas the trailing 1 bit being an end-of-frame. In order to reach the 50Mbit/sec effective transfer rate for the data bits, the LVDS lines were driven at a 11/8 times larger frequency, i.e. at 68.75 MHz because of the overhead of the frame bits.

- The “Command and Deserialiser” unit parallelizes the incoming serial data. It decodes the received commands from the ConcentratorBox and decides what to send as reply: status information, the firmware file or a pedestal table data block.

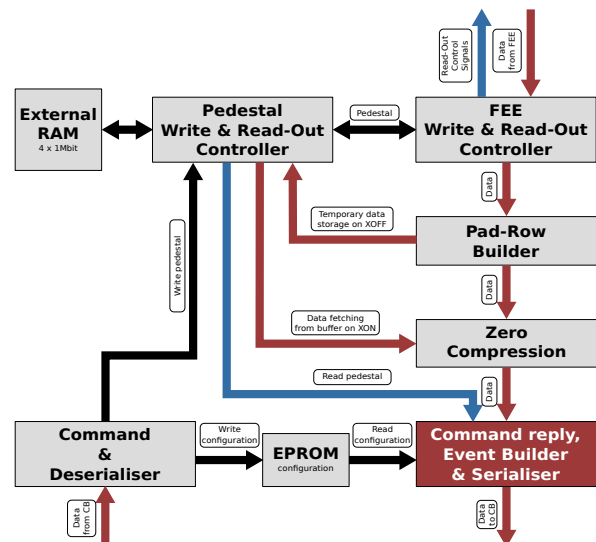

Figure 5: Schematic block diagram of the MotherBoard firmware.

The data stream of a MotherBoard is produced as follows. When the MotherBoard reads the 9 bit ADC charge of a timeslice of a pad, the previously stored corresponding pedestal value is subtracted, and this data word is replaced by zero value in case it is below the predefined noise threshold. After this, the incoming 9 bit data are truncated to 8 bit: if an ADC value is larger than 255, the value 255 is returned instead. After the above processing the data are transferred to a FIFO for each FEE card. From this FIFO these are read out in padrow order and sent to the zero compressor unit. After performing the zero compression the resulting 8 bit wide data stream is written to the output FIFO as shown in Fig. 6. A 1 word (4 Byte) event header containing the

status of the jumpers and the trigger counter precedes the data stream. At the end of the data stream the MotherBoard can send a 4 word (16 Byte) event trailer containing the FEE and MotherBoard voltage values, plus an error and status word to the ConcentratorBox (see Fig. 7). These five status words are optional, but are used by default. When, during data taking, the ConcentratorBox for any reason cannot accept data, the ConcentratorBox sends an XOFF control word to the MotherBoard. Receiving XOFF the MotherBoard stops sending data to the Concentrator. The MotherBoard temporarily stores the data in its output FIFO till the arriving of an XON control word. If during this time the output FIFO becomes full, the MotherBoard can follow one of the two, configurable policies:

1. The MotherBoard continues to read out the FEE cards without loading data into the output FIFO. In this case the event is truncated, which fact is signaled in the error and status word at the end of the event.
2. The MotherBoard, after noise suppression and padrow ordering, sends the data temporary into the higher part of external SRAM memory. Only the higher part can be used for that purpose as the lower part contains the pedestal table. At the moment when free space becomes available in the output FIFO the data are transferred to the zero compressing module. This event of temporary storage is also logged in a warning bit of the error and status word.

Normally, only the latter mode is used, the former mode is applied only in case of very rare calibration runs in the 512 timebin mode. The advantage of the second policy is that the event is transferred as a whole. The above sequence of reading out - pedestal subtraction - noise suppression - padrow ordering - zero compression - sending to ConcentratorBox is repeated until receiving a “Stop Data Taking” command from the Concentrator-Box, which signals the end of a data taking run for the MotherBoard.

The ConcentratorBox receives data packets from the MotherBoards via 32 LVDS channels and forwards their serialized data onto a DDL line, as shown in Fig. 8. The firmware of a ConcentratorBox (Fig. 9) has two main parts: the serializer/deserializer for each channel and the Data Formatter, which creates data structure to be fed to the DDL. For each channel one receiver and one transmitter logic is implemented. The receiver logic recognizes the start and end of event frame, performs serial to parallel data conversion and buffers the data in the receiver FIFO. The transmitter logic reads data from the

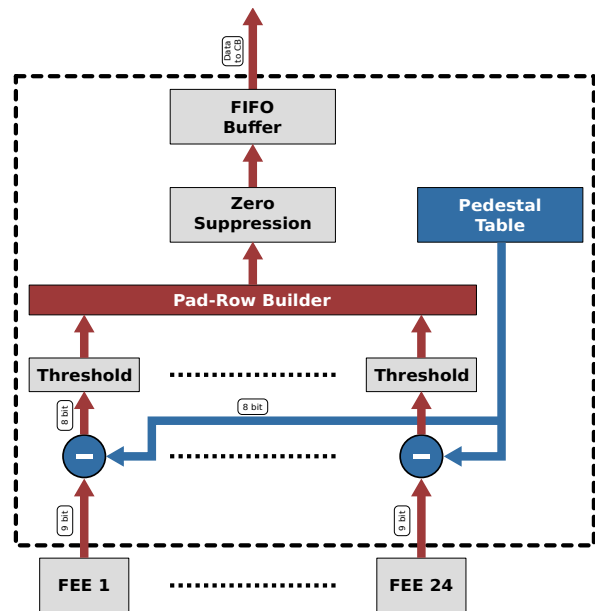

Figure 6: Schematics of the data flow inside a MotherBoard.

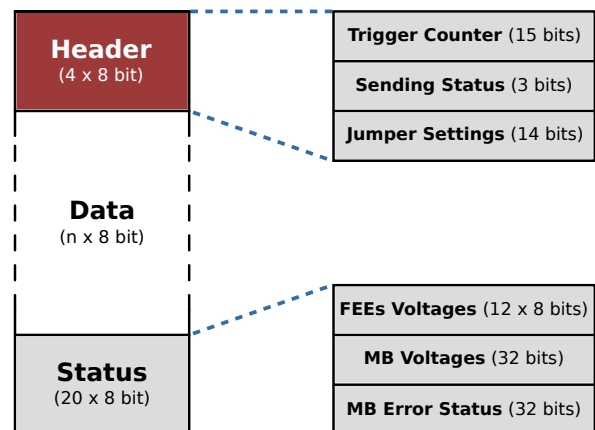

Figure 7: Schematic description of the data structure on a MotherBoard output.

transmitter FIFO, performs parallel to serial conversion, and attaches start of frame and end of frame symbols. Both logics ensure the flow control between the MotherBoard and the ConcentratorBox. The input packets are buffered in FIFOs. The readout of the FIFOs is organized in cycles. In each cycle the firmware reads maximum 128 pieces of 4 Byte data words from each channel’s receiver FIFO in a sequential way. If the FIFO of a channel is empty then the given board is skipped. A so-called mini-header is attached to each data packet con-

taining the identification number of the source MotherBoard and the length of the block. These packets are called “LVDS trains”. The readout cycle continues till the end-of-frame signal is reached in all channels. Before sending the first mini-header an event header is sent to the DAQ. The structure of the data stream transferred to the DDL link is shown in Fig. 10. Upon the arrival of the first data to the ConcentratorBox, a TTL output line is set to logical one level (Busy signal), and this signal persists until the ConcentratorBox recognizes that all data from all of its MotherBoards are drained out. The Busy signal is used for trigger level synchronization of the subdetectors.

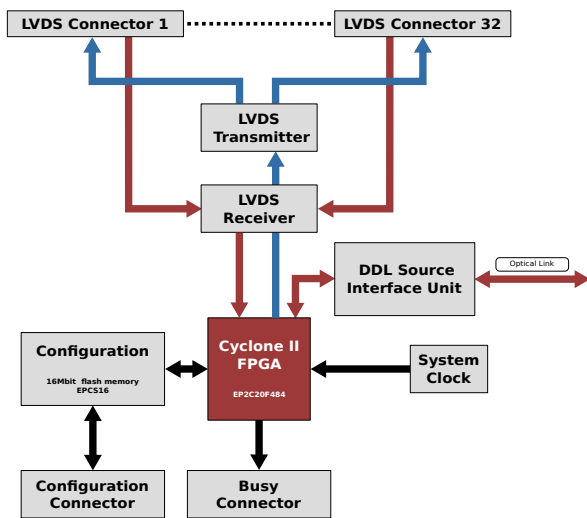

Figure 8: Block diagram of a ConcentratorBox.

The DDL transfers data from ConcentratorBox to RORC plugged in one of PCI-X or PCI-Express slots of the DAQ computer. The DDL works using a push-data mode protocol, i.e. after starting data collection the ConcentratorBox sends the data to the RORC when they are produced, without waiting for any request. The RORC’s task is to transfer the data into DAQ PC’s memory via the PCI bus. To fulfill this task the RORC has a FIFO up to 128 entries which can be filled with PCI addresses and lengths of memory blocks where the data blocks can be written to. When a data block arrives the RORC takes the next address in the FIFO and writes the block there using DMA (Direct Memory Access), without processor intervention. For the DMA, it is necessary to provide continuous physical memory pages. To assure this, we use a special memory tool: the Phymem package, which gives access to a fixed part of the physical memory of a Linux machine for unpagged, un-

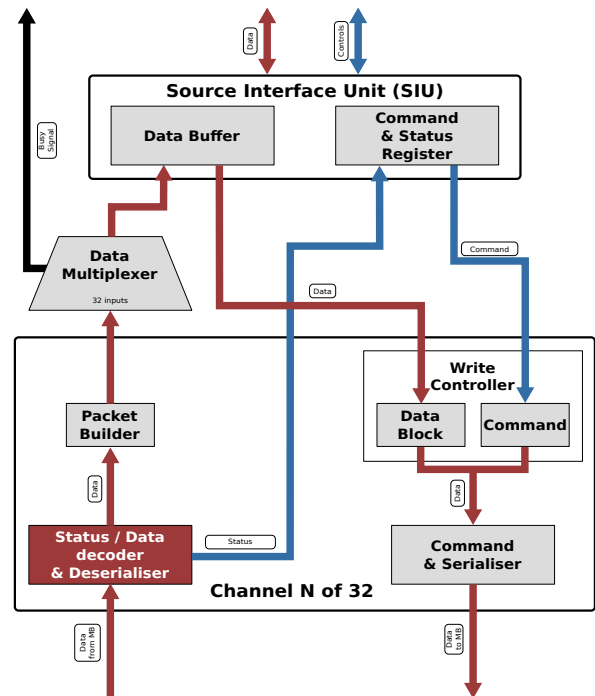

Figure 9: Block diagram of ConcentratorBox firmware.

swapped physical I/O. This memory is outside of the memory assigned for the operating system. However it can be reached by both the kernel and the user processes via the Phymem driver. The package’s driver is loaded as a kernel module at boot time, and care must be taken to limit the memory used by the kernel using boot arguments in order to allow space for the Phymem above Linux memory. The driver provides the user with the physical address and size of the continuous memory which can be used as the destination area of read out data.

During one DMA, only one data page can be written. Data pages that belong to the same event are transferred over the DDL in one or more DDL blocks. Each block can be up to  $4 \times (2^{19} - 1) = 2097148$  bytes. When a data block is transferred into the Phymem memory the RORC puts two control words to a predefined area of memory where it specifies the length of the block and signals if the block is the last one of an event.

For RORC functionality the RORC’s driver module has to be loaded. This driver produces the mapped user addresses of the RORC registers. The pertinent addresses are used for accessing the RORC registers and address FIFO. Using these registers the DAQ program initializes the ConcentratorBoxes and MotherBoards, can send pedestal data, while using the address FIFO

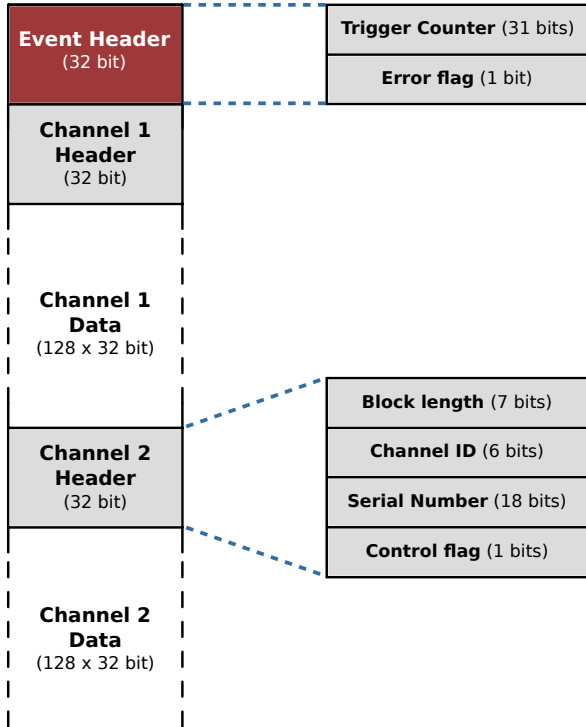

Figure 10: Data structure at the output of a ConcentratorBox.

it can follow the course of the data acquisition.

Presently, the TPC Data Acquisition is steered by the Central DAQ software, and is ran on a single Central DAQ PC with the following parameters: X7DB8-X motherboard, 64 bit, total 8 cores of Intel Xeon CPU at 2 GHz, 8 GByte memory, 6 PCI-X card slots, 4 USB ports, 1 serial port. The computer runs with a 64 bit SLC6 Linux operating system. The memory available for the Linux kernel is restricted to 4 GByte using a kernel argument. The remaining, upper 4 GByte memory is given to the Phymem kernel module, for receiving the subevent data. The built event data are written to a fast temporary disk buffer, consisting of a RAID0 array of 5 pieces of 2 TByte hard disks, providing about 5 times larger bandwidth for writing than a single hard disk.

The data taking cycle of the full TPC system causes approximately 12 ms deadtime, determined by the present setting of TPC FEE cards.

#### 4. Further subdetectors

A number of further subdetectors (PSD, beamline detectors, ToF detector) also needs to be read out along with the tracking data of the TPC system described in

Sec. 3. These, however, only produce small volume data, merely 230 kByte without any compression. Also, their deadtime is smaller than that of the TPC system. The organization of the readout of these subsystems are summarized in the following subsections.

##### 4.1. The readout electronics of the PSD calorimeter

The PSD calorimeter [13] is a very important component of the NA61 experiment for the nucleus-nucleus collision data taking periods. This detector is designed for the determination of collision centrality by measuring the energy of the spectator nucleons, i.e. of beam nucleons not participating in the collision. Its design parameters were set such that its energy resolution allows centrality determination with a precision of  $\pm 1$  spectator nucleon at the lowest used beam energy. The calorimeter consists of 44 modules covering a  $120 \times 120 \text{ cm}^2$  transverse area, and the longitudinal depth covering 5.7 nuclear interaction lengths. The modules of the calorimeter consist of a sequence of lead and plastic scintillator plates, which are grouped into 10 longitudinal sections for shower profile monitoring, the light yield of each section being read out by an MAPD (Micro-pixel Avalanche PhotoDiode). The MAPD signals are stored in time samples and are read out by PSD MotherBoards. These were designed to have similar interface towards the Central DAQ as the TPC MotherBoards, connected to the system via the ConcentratorBoxes. The raw data volume of the PSD subevent is 200 kByte, and its detector readout has a deadtime of 2.5 ms.

##### 4.2. The readout electronics of the beamline detectors

The beamline detectors, such as the beam scintillators, Čerenkov counters and beam position detectors are read out using legacy commercial CAMAC ADC, TDC and scaler modules, altogether  $\sim 300$  channels. A CAMAC-to-VME bridge (CES VIC8251) provides connection to a dedicated VME crate containing a VME controller (CES FIC8234), which runs simple low level readout software. Since the FIC8234 can receive an external trigger interrupt upon the detection of a physical collision, this feature is used for notification of the low level readout software to move the event data via the CAMAC-to-VME bridge into a VME memory module (MicroMemoryInc MM6390), in which these subevents are stored in a ring buffer. This low level DAQ system is self-contained and can run independently from Central DAQ. The Central DAQ PC may access the pertinent MM6390 VME memory module via a VME-to-USB bridge (CAEN V1718) in order to poll for new



subevents. Whenever a new subevent arrives, the Central DAQ PC copies it into its own ring buffer. A data flow blocking mechanism is implemented via a VME commandable register unit (CES RCB8047 CORBO). The Central DAQ can use it to pause the event flow recorded by the low level system in the rare cases of transient bandwidth problems with the moving of the subevent data. The data volume of this subevent is merely 6.5 kByte. The deadtime of this subdetector readout is 11 ms.

#### 4.3. The readout electronics of the ToF system

A quite similar setup is used to read out the 2080 TDC (Time-to-Digital Converter) and QDC (Charge Analog-to-Digital Converter) channels of the ToF system. The legacy Fastbus based TDC and QDC units are linked using a Fastbus-to-VSB bridge (CES LDA9212) to a dedicated VME/VSB crate steered by a VME/VSB controller (CES FIC8234), running a low level readout software. The Fastbus TDC and QDC units are pre-triggered using the 30 ps time resolution start scintillator signal, S1\_1, of the experiment, and the pre-trigger may or may not be confirmed by a 8 ns time jitter Main Trigger signal generated by the trigger logic using further beam counters within a timeout of 300 ns. If the Main Trigger was not present, the TDC and QDC data are cleared using a Fast Clear signal causing only a 1  $\mu$ sec deadtime. Whenever the Main Trigger signal confirmed the pre-trigger, the low level readout software on the FIC8234 controller is notified via its external interrupt port. The TDC and QDC data are moved via the Fastbus-to-VSB bridge into the internal memory of FIC8234, and these subevents are stored in a ring buffer scheme. The Central DAQ PC polls this ring buffer for new events and moves them away via a VME-to-USB bridge (CAEN V1718) and propagates them to its own ring buffer in memory. The data flow control to the Central DAQ is again realized via a VME configurable register unit (CES RCB8047 CORBO) in order to prevent the low level ring buffer from overwriting itself before the moving of the subevents by the Central DAQ takes place. The data volume of this subdetector is 21 kByte, and its deadtime is 8 ms.

An overview of the organization of the entire NA61 readout system including the legacy beam detector and ToF readout is outlined in Fig. 11. The legacy FEEs of the ToF detectors as well as the beamline detectors are foreseen to be upgraded using the new DRS technology [14] in the near future, and their data transmission scheme is foreseen to be adapted to that of the TPC system discussed in Sec. 3 based on DDL [10] technology.

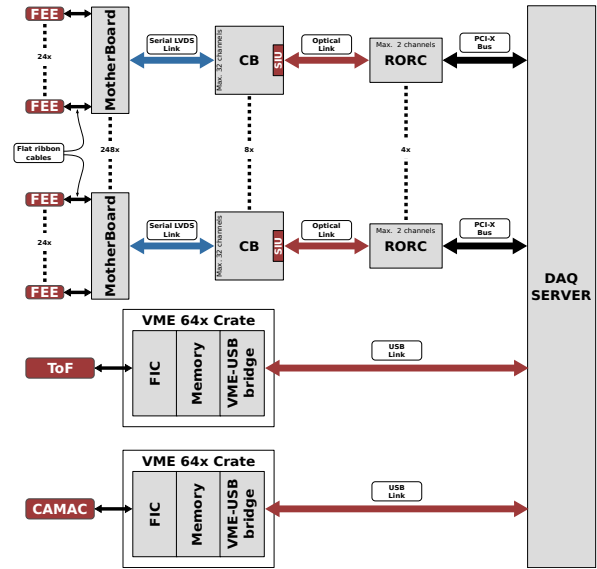

Figure 11: Overview of the entire data acquisition system of NA61 along with the new TPC readout system, PSD readout system and the legacy beam detectors and ToF system.

## 5. Signal and data flow

As mentioned previously, in the full experimental setup the data taking is controlled via a set of trigger signals from beam counters and Busy signals from sub-detectors. These communication lines, along with the actual data flow lines within the experimental setup are summarized in Fig. 12. The S1\_1 signal serves as a timing reference and a pre-trigger for the detector complex. The signal of the V1 veto counter, used for filtering out already scattered beam particles just upstream of the target, is applied as a pre-trigger-veto. The rest of the counter signals (S2, V0, V1', CEDAR, Z Detector, S4, S5) have somewhat worse time resolution and are used by the Trigger Logic coincidence unit to build the final Main Trigger signal, confirming the pre-trigger. If all the subsystems are in a state that is ready for data taking, the Busy Logic lets the Main Trigger pass, and thus generating the Main Trigger Accepted signal in order to start actual reading out of the detector data. The pathways of the data flow from the subdetectors, such as the TPC, the PSD, the ToF and beam counter systems are also indicated.

## 6. Data synchronization

The synchronization of the deadtime of the subdetectors for each event is done by a Busy Logic system. This

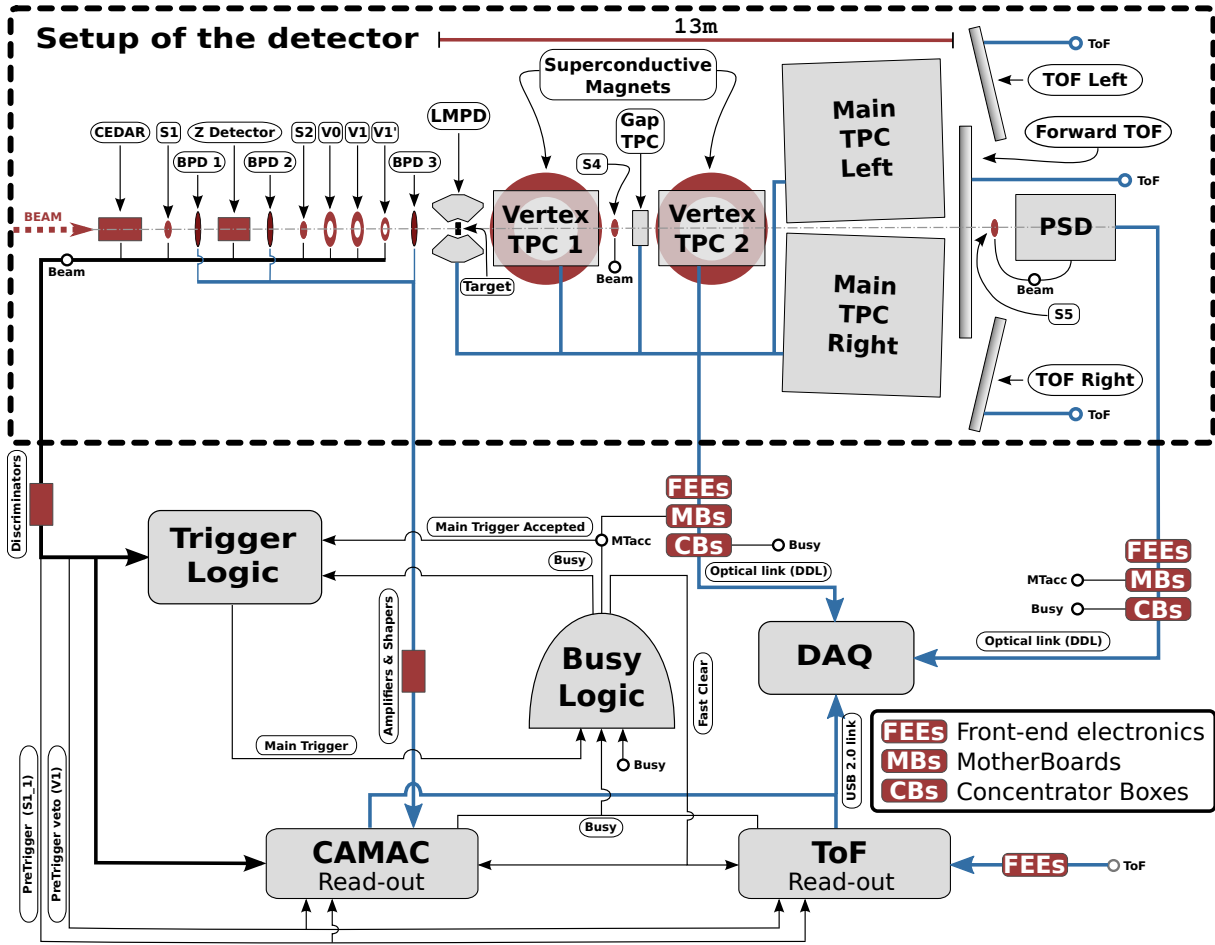

Figure 12: Summary figure showing the signal and data flow lines within the NA61/SHINE experimental setup. The work cycle is started by the signal of the best time resolution photomultiplier of the S1 counter (S1\_1) as a pre-trigger, and may be vetoed by the signal of V1 as a pre-trigger-veto in order to filter out deflected beam particles. The rest of the beam counters are used by the Trigger Logic to build a Main Trigger signal confirming the pre-trigger. In case all the subsystems are in ready state, the Busy Logic lets the Main Trigger pass, triggering the actual data readout. The data flow lines from the subdetectors are also indicated.

vetoed the trigger signal distributed to all the subsystems in case any of the subdetectors are not in their ready states, which is determined via a Busy signal from each subdetector. In addition, the trigger is also blocked if any of the fast systems (beam detectors, or ToF system) received a pre-trigger, i.e. an S1\_1 signal not vetoed by V1.

As the NA61 DAQ system is organized in a push-data mode, i.e. the low level systems receive the data taking trigger independently and they push their data asynchronously to a higher level, some kind of protection mechanism is needed for checking against any mixing of subevents in the parallel data streams. Initial synchronization of the readout systems of all the subdetectors occurs at the start of a data taking run, when all the

subdetector trigger counters are reset. In order to maintain this synchronization, we use the fact that the SPS beam is provided to NA61 experiment in  $\sim 10$  sec long “spills” with at least 5 sec break in between them (in the most usual data taking conditions the duty cycle is about 30%). During the spill breaks, all the data channels toward the Central DAQ are emptied. Upon detecting a stop of event flow for 3 seconds, the trigger counters in the subevent data channels are cross-checked as they should be equal if no false trigger has been received by any subdetector and if no subdetector failed to receive a true trigger. In case the trigger counters are equal, the corresponding identifier of the last recorded event is marked as the last good one, and is approved for archiving. In the rare cases when this check does not pass,

the data taking run is halted, the event stream is deleted back to the last good event, the Central DAQ issues an error message of “trigger skew”, and a completely new data taking run is started with all the subdetectors fully reset. Such a recovery run stop-and-start takes about 1 minute.

A further crash scenario can occur when the finalization of the subevent by one of the subsystems is unfinished, i.e. the end-of-subevent trailer in a given channel does not arrive. In such case, the Central DAQ issues an “event reading timeout” within 1 second and a completely new run is started with subdetectors reset.

A very rare but very harmful crash scenario is when a subsystem starts data taking e.g. due to a false trigger, but is not able to send the subevent header to the Central DAQ due to some internal inconsistency. In such case the Central DAQ cannot know that the recording of a new event has been started and therefore cannot time out. However, since the data taking cycle has begun, the given subsystem sets its busy signal thus blocking the arrival of any further trigger signals. In such scenario the data taking would hang completely without any particular error message until human intervention could detect and resolve the problem. Therefore, a custom made TTL register module was built in order to monitor the busy signals of all the subdetectors. The pertinent register can read 16 TTL signals which are visible to the Central DAQ PC via its RS232 serial port. Whenever the subevent flow comes to a standstill the busy register is checked that none of the busy signals remained in the “true” state. In case any of the busy signals remain in “true” 1 second after the halt of the event flow, a “a busy signal got stuck” error is issued by the Central DAQ and a completely new run is started with subdetectors reset. In order to maintain galvanic isolation of the Central DAQ PC, an optical RS232 coupler is used.

The occurrence rate of any kind of data inconsistency condition in the data stream during stable data taking is seen to be about 0 to about 5 times a day, which is considered to be well tolerable. These failures are normally traced back to some infrastructural problem such as power supply or cooling water service instability.

## 7. The readout/online software

The structure of the Central DAQ software, called Runcontrol consists of the following 9 subprocesses.

1. *GUI*: the GUI of the software is a Tcl/Tk [15] wrapper script, providing a user friendly interface.
2. *Runcontrol*: the core software under the GUI is written in C language, running autonomously. Its

user interface is a simple shell-like command line interpreter based on GNU Readline Library [16]. For experts, it is possible to use this shell-like command line environment for debugging mode, however, normally it is handled by the GUI, emulating user commands which are sent and received between the command line interpreter and the GUI via unix pipes and log files.

3. *Event Server*: whenever the core of Runcontrol is started, an event server process is created. This is a fork-server and can serve up to 16 monitoring clients for online event display.
4. On top of the above, the following processes are launched upon start of a data taking run:
  - (a) *Logger*: this is logger and consistency checking process. It is also responsible for checking the trigger counter synchronization of all subsystems whenever there is a pause in the data stream. In case the trigger counters on the incoming DDL and VME channels are inconsistent, a “trigger skew” error is issued and a completely new run is started with subdetectors reset. Also, the busy signals of the subsystems are monitored by this process using our custom made register unit accessible via the serial port.
  - (b) *Trigger Client*: this is a process for communication with the Trigger System. This client retrieves scaler counts and other trigger summary information at the end of each spill, and writes it into the data stream for monitoring purposes.
  - (c) *DCS Client*: this is a process for communication with the DCS (Detector Control System), responsible for monitoring the slowly changing detector parameters, such as temperatures, high voltages etc. This process periodically retrieves logs from the DCS system and appends to the event data stream for monitoring purposes.
  - (d) *Recorder*: this process is responsible for collecting the subevents on a first come first served basis from the data channels of the receiver processes. It collects the subevent data addresses in an event data pool for each incoming subdetector data channel. If the end-of-event trailer arrives in each data channel, it builds the event directly onto disk following an internal consistency check. Upon request, it also duplicates in memory the event being built for the Event Server process. The Recorder process has two further processes

subordinate to it for efficient parallelization of the data receiving procedure.

- i. *DDL Receiver*: this process waits for subevent data delivered by the RORC cards and forwards their address on a first come first served basis to the Recorder process. The RORC cards deliver the event data to the pre-allocated Phymem area without CPU intervention. The addresses of the available Phymem pages, returned by the Recorder, are filled by this process to the RORC cards internal FIFO. In the pathological case when the Recorder cannot build the events fast enough, the RORC cards may run out of free Phymem page addresses. In that case, the RORC cards stall the data stream via issuing an XOFF signal towards the DDL lines. The data stream is restarted by XON, when addresses of new free Phymem pages arrived into the internal FIFO of the given RORC card.
- ii. *VME Receiver*: this process polls for subevent data in the VME memory of the low level systems, accessed via the CAEN V1718 VME-to-USB bridge units. Whenever a new subevent is detected in any of the subsystems, it is copied to the Phymem area allocated for this process, is stored in a ring buffer, and the subevent address is passed to the Recorder process. In the pathological case when the Recorder cannot drain the subevents fast enough, the following event triggers are blocked by commanding our VME controllable TTL register units (CES RCB8047 CORBO) to issue a busy signal.

The non data intensive inter-process communication of the 8 subprocesses of the core of the Runcontrol software is solved using standard Linux shared memory. For the data intensive inter-process buffering, the Phymem area is used instead, in order to avoid unnecessary overhead by the Linux kernel. The data flow of the Central DAQ software during data taking is illustrated in Fig. 13.

The DAQ software produces its final output data stream as a sequence of 1 GByte files, called chunks, for easier handling. Whenever the currently being written chunk exceeds 1 GByte, the corresponding chunk is

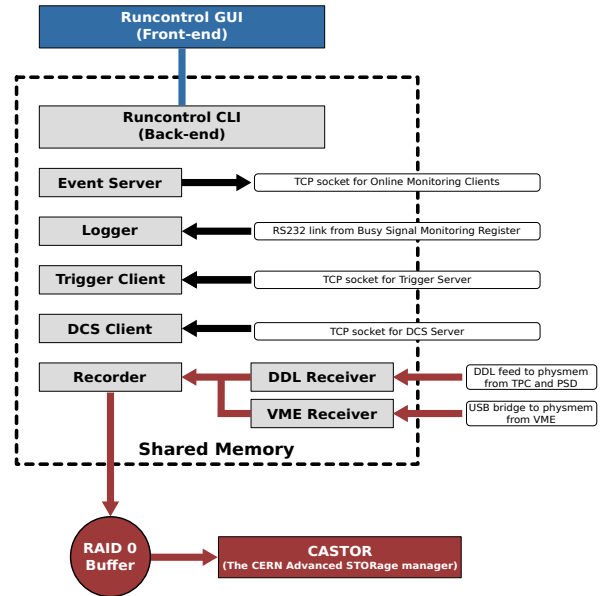

Figure 13: Sketch of the data flow of the Central DAQ software, the Runcontrol, during data taking run. The figure also depicts the process hierarchy, consisting of 9 individual subprocesses. The DDL Receiver and VME Receiver lay the arrived data into Phymem pages, and these page addresses are passed to Recorder for event building. After the Recorder has built the events onto disk, it recycles addresses of the free Phymem pages to DDL Receiver and VME Receiver.

closed and the following event is written to a new chunk. The chunks are written to the RAID0 buffer disk in order to reach the necessary bandwidth for writing (the writing bandwidth to a RAID0 disk is larger than to a single disk).

The DAQ software is supplemented with a set of failure-tolerant system of scripts, responsible for final treatment of the chunks.

1. Online QA (Quality Assessment) of the newly arrived raw data chunks via a dedicated online QA software for fast integrity checks and for acquiring histograms of important basic quantities for monitoring and sending them for online display. That piece of software is using the standard NA61 offline software framework, called Shine [17]. Subsequently, the properties of the produced control histograms are also automatically verified by a simpler program (“Electronic Shifter”). In this way, an alarm can be issued whenever e.g. a well-defined detector failure occurs. The QA procedure is performed via two independent processes for efficient parallelization.
2. Copying of the certified raw data chunks to the CASTOR archiving system [18] of CERN. This is

performed via two independent processes for efficient parallelization.

3. Verification of the raw data chunks on tape. The CASTOR system provides the Adler32 checksum and size of the chunks migrated to tape. These two verification parameters are cross-checked with that of the chunk on the Central DAQ PC's RAID0 buffer disk by a script. The local copy on the Central DAQ PC is deleted whenever the verification passes. In the rare cases when verification fails, the raw data chunk is kept on the Central DAQ PC for human intervention.

## 8. Raw data structure

Book-keeping of the DDL page structure along with the "LVDS train" substructure of the data stream is performed by the DDL Receiver process. These are unfolded from the data stream at the event building level upon writing to disk, in order to have contiguous binary data from each MotherBoard, free from all the data frames used only for communication protocols between MotherBoard and ConcentratorBox, or ConcentratorBox and Central DAQ. The subevent data from the beam detector system or the ToF system are already built by the low level FIC controllers, and are simply received by the VME Receiver process and passed over for event building without modification.

The raw data structure written by the Central DAQ is organized as follows. Each event is written on disk after each other as a Record, consisting of a sequence of 4 Byte integer words, the first word encoding the number of words in the Record (inclusive), followed by the data words of the Record. The data words are organized in BOS (Bank Objective System) banks, consisting of a 4 word header and a sequence of data words within the BOS Bank. The first BOS header word is the identifier of the type of subdetector data, the second BOS header word is a geographical detector identifier, the third BOS header word is reserved (set to zero), and the fourth BOS header word encodes the number of following data words (exclusive) within the BOS Bank. The 4 Byte words in the event data stream, whether interpreted as integers or floating point numbers, are always encoded in the "network byte order", also called "Big-Endian format".

The most important BOS Banks are the followings: EVEH (event header data), CAMC (beam detector data), TOFD (ToF data), MBRD (TPC MotherBoard data), MBLV (TPC MotherBoard housekeeping parameters, i.e. low voltages, temperatures), PSDD (the same

as MBRD for the PSD detector), PSLV (the same as MBLV for PSD detector).

The used raw data structure based on Record and BOS Banks proved to be a flexible way for extension of the detector system or for deprecation of old subdetectors.

The size of a "black event" (event without pedestal subtraction, noise suppression and zero compression) is 100 MByte if the TPC drift time is sampled in 512 timebins, whereas 50 MByte in case of the typically used 256 timebins. For a normal event (event with pedestal subtraction, noise suppression and zero compression), the typical size is 1.5-5 MByte, slightly depending on track the multiplicity in the event.

## 9. Performance

The presented readout and Data Acquisition system was set first in operation in 2009, with the start of the data taking program of NA61/SHINE. After initial debugging, it served as a very reliable system throughout the extended data taking periods of 2-5 months per year, and so far only minor upgrades were needed. The total deadtime, 12 ms, of the system proved to be sufficient to complete the experimental program in a timely manner. Improvement on the deadtime would not provide further significant benefits as presently our data taking rate is limited by the available beam intensity for most of the collision types as well as the limited target thickness in order to suppress secondary collisions. Therefore, the construction is considered quite mature and stable. The acquisition system was used to record a large amount of physics data on 29 kinds of reactions, with the number of events ranging from 1 to 40 M, totaling up to 194 M recorded physics events during the years 2009-2015. It is expected that a further 20 kinds of reactions will be recorded through 2015-2019, typically comprised of 4 M events each.

## 10. Concluding remarks

The design concepts and the used technologies of the readout system of the NA61/SHINE experiment at the CERN SPS were summarized. Special emphasis was given to the readout of the large, 40 m<sup>3</sup> TPC system; the most important detector component in the complex. The readout technology is largely based on the DDL data transmission, also used in ALICE. The present system provides possibility for reading out physics events at a rate of 83 Hz, which satisfies the present needs given the upper safety limit of usable beam intensity. The

raw event size is 50 MBytes, which after compression reduces to 1.5-5 MByte depending on the number of particles in the event (1-1500). The described system serves since 2009 and recorded a large data set of 194 M physics quality collision events. Data taking is foreseen through at least 2019, with possible upgrades to the ToF detector.

## Acknowledgments

This work was supported in part by the Momentum (“Lendület”) program of the Hungarian Academy of Sciences, as well as the János Bolyai Research Scholarship of the Hungarian Academy of Sciences. Funding from the grant NKTH 68506 is also acknowledged. We wish to thank to the support and help from all the members of the CERN NA61/SHINE Collaboration.

## References

### References

- [1] NA61 webpage: <http://na61.web.cern.ch>
- [2] N. Abgrall *et al* (the NA61 Collaboration): *Study of Hadron Production in Hadron-Nucleus and Nucleus-Nucleus Collisions at the CERN SPS*; Proposal for the NA61/SHINE experiment [<http://cdsweb.cern.ch/record/995681/files/spsc-2006-034.pdf>].
- [3] A. László (for the NA61 Collaboration): *NA61/SHINE at the CERN SPS*; PoS **CPOD07** (2007) 054.
- [4] A. László (for the NA61 Collaboration): *The NA61/SHINE Experiment at the CERN SPS*; Nucl. Phys. **A830** (2009) 559c.
- [5] N. Abgrall *et al* (the NA61 Collaboration): *NA61/SHINE facility at the CERN SPS: beams and detector system*; J. Instr. **9** (2014) P06005.
- [6] S. Afanasiev *et al* (the NA49 Collaboration): *The NA49 Large Acceptance Hadron Detector*; Nucl. Instr. Meth. **A430** (1999) 210.
- [7] K. Márton, G. Kiss, A. László, D. Varga: *Low momentum particle detector for the NA61 experiment at CERN*; Nucl. Instr. Meth. **A763** (2014) 372.
- [8] F. Bieser *et al*: *Design and performance of TPC readout electronics for the NA49 experiment*; Nucl. Instr. Meth. **A385** (1997) 535.
- [9] S. A. Kleinfelder: *A 4096 Cell Switched Capacitor Analog Waveform Storage Integrated Circuit*; IEEE Transactions on Nucl. Sci. **37** (1990) 1230.
- [10] G. Rubin, P. Vande Vyvre, P. Csató, E. Dénes, T. Kiss, Z. Megyesi, J. Sulyan, G. Vesztegombi, B. Eged, I. Gerencsér, I. Novák, C. Soós, D. Tarján, A. Telegdy, N. Tóth: *The ALICE Detector Data Link*; Proceedings of the Fifth Workshop on Electronics for LHC Experiments (LECC 1999), p.493.
- [11] W. Carena, F. Carena, S. Chapeland, E. Dénes, R. Divi, T. Kiss, J. C. Marin, K. Schossmaier, C. Soós, A. Vascotto, P. Vande Vyvre: *The ALICE Data-Acquisition Read-out Receiver Card*; Proceedings of the 10th Workshop on Electronics for LHC Experiments (LECC 2004), p.273.
- [12] E. Dénes, T. Tölyhi, C. Soós, T. Kiss, Z. Fodor, A. László: *NA61 TPC Read-out*; Specification of the NA61 TPC read-out electronics and firmware (2010), NA61 Internal Note.

- [13] M. Golubeva *et al*: *Forward hadron calorimeter for measurements of projectile spectators in heavy-ion experiment*; Phys. Atom. Nucl. **75** (2012) 673.
- [14] S. Ritt *et al*: *Application of the DRS chip for fast waveform digitizing*; Nucl. Instr. Meth. **A623** (2010) 486.
- [15] Tcl/Tk: <http://www.tcl.tk>
- [16] GNU Readline Library: <http://www.gnu.org/s/readline>
- [17] R. Sipos, A. László, A. Marcinek, T. Paul, M. Szuba, M. Unger, D. Veberic, O. Wyszynski: *The Offline Software Framework of the NA61/SHINE Experiment*; J. Phys. Conf. Ser. **396** (2012) 022045.
- [18] CASTOR: <http://castor.web.cern.ch>