

Performance Evaluation of ECC in Single and Multi Processor Architectures on FPGA Based Embedded System

Sruti Agarwal^{1,*}, Sangeet Saha², Rourab Paul³, Amlan Chakrabarti⁴

Abstract

Cryptographic algorithms are computationally costly and the challenge is more if we need to execute them in resource constrained embedded systems. Field Programmable Gate Arrays (FPGAs) having programmable logic devices and processing cores, have proven to be highly feasible implementation platforms for embedded systems providing lesser design time and reconfigurability. Design parameters like throughput, resource utilization and power requirements are the key issues. The popular Elliptic Curve Cryptography (ECC), which is superior over other public-key crypto-systems like RSA in many ways, such as providing greater security for a smaller key size, is chosen in this work and the possibilities of its implementation in FPGA based embedded systems for both single and dual processor core architectures involving task parallelization have been explored. This exploration, which is first of its kind considering the other existing works, is a needed activity for evaluating the best possible architectural environment for ECC implementation on FPGA (Virtex4 XC4VFX12, FF668, -10) based embedded platform.

Keywords: FPGA, ECC, single-core, dual-core, MicroBlaze, shared memory

*Corresponding author

¹Institute of RadioPhysics and Electronics, University of Calcutta, Kolkata.

²CSE, University of Calcutta, Kolkata.

³A.K.Choudhury School of I.T., University of Calcutta, Kolkata.

⁴Senior Member IEEE, A.K.Choudhury School of I.T., University of Calcutta, Kolkata.

1. Introduction

ECC is an approach to public-key cryptography based on the algebraic structure of elliptic curves over finite fields. The use of elliptic curves in cryptography was suggested independently by Neal Koblitz[1] and Victor S. Miller[2] in 1985. Elliptic curve cryptography, in essence, entails using the group of points on an elliptic curve as the underlying number system for public key cryptography. The primary reason for using elliptic curves as a basis for public key crypto-systems is that elliptic curve based crypto-systems appear to provide better security than traditional crypto-systems for a given key size[4], thereby reducing the process overhead. One can take advantage of this fact to increase security, or (more often) to increase performance by reducing the key size while keeping the same security.

Designers are now working on designing dedicated hardware accelerator blocks along with the main processor [5][7][8] to increase the throughput of the design. ECC algorithm is used for secured communication in smart cards[9] and also in GSM security[6]. So, high speed, resource constrained environment is required. Using a dual-core instead of a dedicated co-processor enables the user to operate from the application layer without entering the subordinate layers. Also, the thread-level parallelism, used by the dual-core ensures higher throughput without increasing the much power, which is an important issue for low-power communication devices like smart cards. Implementations can be made in different platforms namely, FPGA or ASIC or can be done using micro-controllers. FPGAs provides reconfigurability and lesser design time, while ASIC provides better throughput though the design time is large and expensive. We propose the design and implementation of Elliptic Curve Cryptography (ECC) encryption algorithm by developing suitable single core and dual core design on Xilinx Virtex 4 (ML403) device. The system is optimized in terms of execution speed. We perform a trade-off between throughput, power and resource requirements for our dual core implementation. To the best of our knowledge, dual-soft core processor based implementation of ECC in an FPGA is not yet available in related literatures and hence it is first of its kind.

The paper is organized as follows: Section 2 details the overview of ECC, the encryption and decryption process. The design and implementation details for single and dual-core processor architectures are described in Section 3. The experimental results are summarized in Section 4. Conclusion and References are briefed in Section 5.

2. Background

This section provides some background on elliptic curves and ECC and then the hardness of decrypting the elliptic curve ciphers is also discussed. The idea of a multi processor system, establishment of communication between the processors using shared memory and the needed data synchronization is also briefed in the later part of this section.

2.1. Elliptic Curves

Elliptic curves are described by curves, which are similar to cubic equations, used for calculating the circumference of an ellipse. In general, cubic equations for elliptic curves take the following form known as Weierstrass equation[3]:

$$(y^2 + axy + by) \bmod p = (x^3 + cx^2 + dx + e) \bmod p \quad (1)$$

where a, b, c, d, e, p are real numbers and x and y take on any values in the real numbers. For our purpose, it is sufficient to limit ourselves to equation of the form given in Equation2 for appropriate curve parameters of ECC.

$$y^2 \bmod p = (x^3 + ax + b) \bmod p \quad (2)$$

Figure 1 shows an example of elliptic curve.

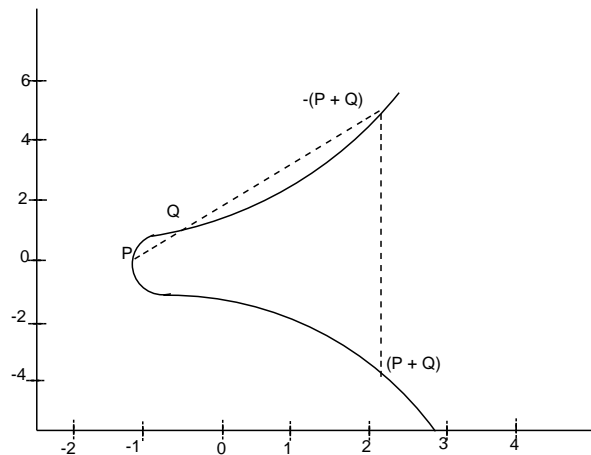

Figure 1: Example of Elliptic Curve

2.2. Elliptic Curve Cryptography

ECC can be used to encrypt a plain text message M into cipher text for secured communication. Firstly, the plain text message M is converted into a set of finite points $P_M(x, y)$, which lie in the elliptic curve $E_p(a, b)$. A generator point, $G \in E_p(a, b)$, is chosen next such that the smallest value of n for which $nG = O$ is a very large prime number. The elliptic curve $E_p(a, b)$ and the generator point G are then made public.

Let there be two parties A and B who wish to communicate using ECC. Each user selects a private key, user A's private key is n_A , while n_B is the private key for user B such that $n_A, n_B < n$. Then they compute their public keys. The public key of A is $P_A = n_A G$, while for B the public key is $P_B = n_B G$. To send the secret message to B, A encrypts the message point P_M by choosing a random number k and computes the cipher text points C_M using B's public key. The cipher text is given by:

$$C_M = [(kG), (P_M + kP_B)] \quad (3)$$

On receiving the cipher text (pair of points) C_M , B multiplies the first pair of points (kG) with his private key n_B , and then adds the result to the second point of the cipher text $(P_M + kP_B)$ i.e.,

$$(P_M + kP_B) - [n_B(kG)] = (P_M + kn_B G) - [n_B(kG)] = P_M \quad (4)$$

Plain text message point P_M , corresponds to the message M . It is to be observed here that only B can remove $n_B(kG)$ from the second part of the cipher text. No, third party or intruder can know the message except B. Thus, ECC is very secured and can be relied for confidential communication. Breaking of ECC is a "hard problem", which requires computing of discreet logarithm [3].

2.3. Multi processor system

A multi processor system consists of two or more processors working concurrently and capable of communicating with each other. Such a design tends to double the throughput, with two processors running independently, but with an extra cost of resource and power. On the other hand, a multi core system is one in which more than one processor is build on the same die. In FPGA we have on-chip soft processor cores, which has been utilized in our design to multi core design. There are some basic conditions required for the execution of a design in a multi core system. The primary being concurrency

in the design i.e., no data dependency must be present in processes that run in different processors and also the two processors must have some handshaking for synchronization of data. Multi core processors often use a shared memory system or a Mailbox system as a interprocessor communication mechanism, that operates very quickly[11].

2.4. Shared Memory

In a multi core environment, mailbox and shared memory [12] are the two mechanisms, provided by Xilinx. Out of these two mechanisms, shared memory is the most common and most intuitive way of passing information between processing subsystems and we have used it in our design.

A shared memory system has the following properties[12]:

- Any processor can refer any location in the shared memory directly by some system call.
- Location of data in memory is transparent to the programmer. Data could be distributed across multiple processors, with the help of some proper API, data can be handled at program level.
- A synchronization is a must for accessing the shared memory segment by some hardware/software protocol between the two processors.

Shared memory is typically the fastest asynchronous mode of communication, especially when the information to be shared is large. Shared memory gives another approach of "in-place" message processing schemes. Shared memory can be built out of on-chip local memory like BRAM or on external memory like DDR SDRAM.

2.5. Synchronization

The region in which the shared data is stored is known as a Critical Region in operating system terminology. Unless there is some sort of well-defined non-conflicting way in which each processor accesses the shared data, the multi core system cannot work properly. A synchronization protocol or construct is usually required to serialize accesses to the shared resource.

The XPS Mutex synchronization primitive is used in this work, which is provided by Xilinx as a separate IP-core[13]. When using Shared memory as a method of data communication, the pseudo code should look like this to ensure proper synchronization,

```
/* shared tasks */  
XMutex_Lock ();
```

```
/* Critical Region - Perform shared memory access */  
XMutex_Unlock ();
```

By calling the *XMutex_Lock()* it must be ensured that one processor is accessing the critical region and other processor should not be allowed to access the same until *XMutex_Lock ()* is called by that processor.

3. Design and Implementation

This section highlights the key components of our proposed design. At first, we describe the processor that is used and then we brief the design innovations made to enhance the throughput.

3.1. MicroBlaze

The MicroBlaze embedded processor soft core is a 32-bit Reduced Instruction Set Computer (RISC) optimized for implementation in FPGAs[10]. As a soft-core processor, MicroBlaze is implemented entirely in the general-purpose memory and logic fabric of Xilinx FPGAs. The Embedded Development Kit (EDK) platform from Xilinx has been used to build a complete processor system on FPGA.

3.2. ECC in Single MicroBlaze

In a single processor architecture, the FPGA receives the input via the RS-232 port through UART and then the input plaintext message is encrypted using ECC algorithm, which is running in the MicroBlaze processor of the the FPGA. After encryption, the cipher text is send back to the Host PC and is seen in the Hyper Terminal using serial communication between the board and the PC. Figure 2 shows the flow of steps in the design. Processor working at 100MHz clock frequency is used to encrypt 8-bits of message using ECC. Scalar multiplication constitutes the main operation in ECC. It is seen that the processor takes 19.01 msec to perform the total encryption. The resource utilized i.e., the number of LUTs and slices required by the design as well as the power requirements are summarized in the table 2.

3.3. ECC in Dual MicroBlaze

After evaluating the performance of ECC in single processor architecture by using MicroBlaze soft-core processor, another approach is taken to implement it in Dual processor architecture by considering the fact discussed in Section 2.3 for higher throughput and efficiency. Xilinx Virtex4 ML403

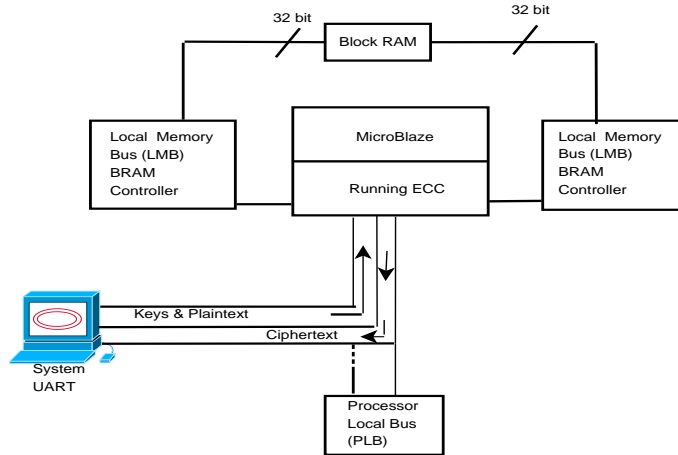

Figure 2: Single MicroBlaze Architecture

is taken as a platform for design. Shared memory is used for creating a handshaking between the two processors as described in Section 2.4 and the synchronization for communication is achieved using the process described in Section 2.5. Fig. 3 shows the architecture of Dual MicroBlaze design,

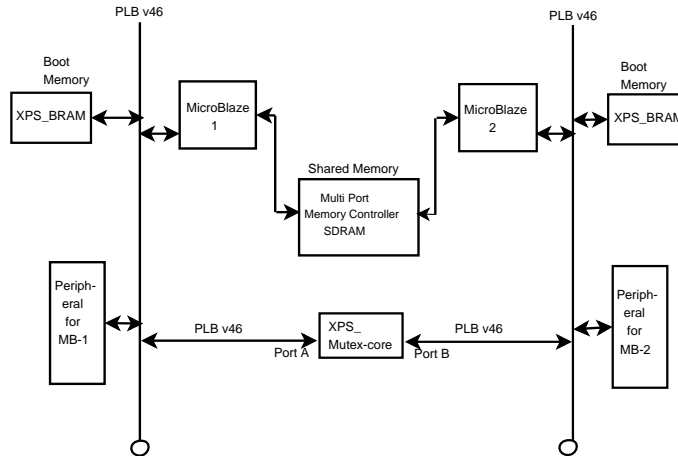

Figure 3: Dual MicroBlaze Architectural flow

In addition, multiple port memory controller (DDR_SDRAM) and inter-processor communication-XPS Mutex hardware IP [13] is also incorporated in the test bed to facilitate the memory sharing and inter processor synchronization and communication.

In the experiment, the two processors are equally engaged to execute ECC in parallel fashion and in between the consequent steps, the two processors communicate with each other via shared memory with proper synchronization. The message to be encrypted is transferred to the FPGA from

a computer using RS232 serial port communication. The two multiplications are executed concurrently in two processors and the resulting data is assembled in the shared memory. The addition operation is then performed by the 1st processor and the resultant cipher text is generated. The resultant cipher text is send back to the PC using the RS232 interface and is viewed at the Hyper Terminal of the computer. Fig. 4 shows the mechanism in which the two processors communicate using the shared memory and using Mutex locking and unlocking.

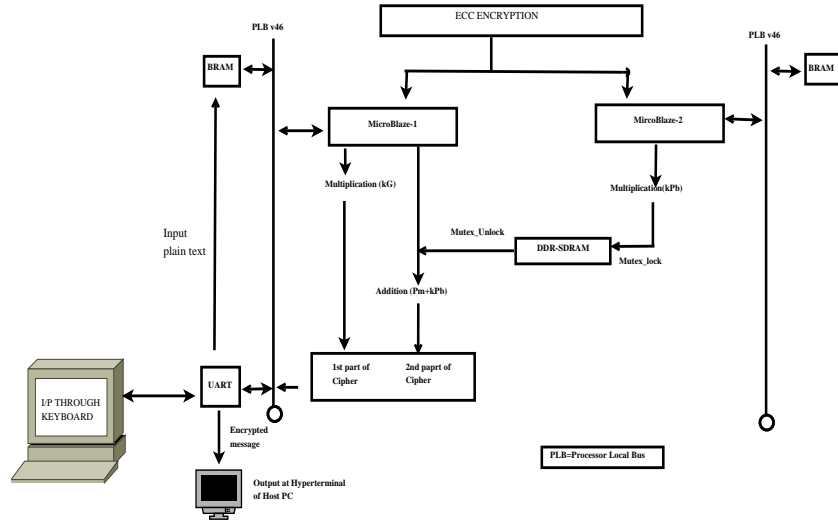

Figure 4: ECC in Dual MicroBlaze

4. Result and Analysis

It is seen that the encryption engine speeds up by 3.3 times as the proposed architecture takes only 5.72 msec to perform the encryption. The resource estimation, power required and throughput measurements for both the designs are shown in Table 1 and Table 2 below. The design improves the throughput of execution, but utilizes more resources due to the dual cores. It is to be noted here that the throughput of the design can be improved further by enabling the cache memory. But due to the resource constraints of our implementation board the cache memory of the two processors could not be enabled.

5. Conclusion and Future Work

This work is an exploration of ECC implementation for FPGA based embedded systems. Two specific designs have been addressed, the first one

Table 1: For an encryption process

Architecture	Clock Freq. (in MHz)	# clock cycles reqd.	Time Reqd. (in msec)	Throughput (bits per sec)
Single-core Microblaze	100	1901317	19.01	420.83
Dual-core Microblaze	100	572552	5.72	1398.60

Table 2: Resource and Power Estimation for the encryption process

Processor	Clock Freq. (in MHz)	# Slices	# Slice FFs	# 4-input LUTs	Through put per slice	Total Power (in Watts)
Single-core Microblaze	100	3580	3750	4076	0.1175	1.106
Dual-core Microblaze	100	5313	6637	7495	0.2632	1.808

is simpler involving a single Microblaze core whereas the other one utilizes two Microblaze cores and thus enables multi-threading. The dual core based implementation gives almost a 3 times increase in the throughput but utilizes almost twice the resource and 30% more power as compared to the single core based implementation. This clearly shows a trade off between speed, resource utilization and power requirement. In future we look forward to do a further exploration of ECC implementation for embedded applications involving FPGA based hard processor cores and ASIC based design.

References

- [1] Koblitz Neal, “Elliptic Curve Cryptosystems,” *Mathematics of Computation* 48 , (177): 203–209. JSTOR 2007884.
- [2] Miller Victor, “Use of elliptic curves in cryptography,” *CRYPTO 85* : 417–426 *doi* : 10.1007/3 – 540 – 39799 – X_31.
- [3] Stalling William, “Cryptography and Network Security: Principles and Practice (6th Edition),” , ISBN: 0133354695.
- [4] Batina L., Ors S., Preneel B., Vandewalle J., “Hardware architectures for public key cryptography,” *Integration, the VLSI Journal*, 34(1-2):1-64, 2003.

- [5] Sozzani Fabio, Bertoni Guido, Turcato Stefano, Breveglieri Luco and Milano P, “A parallelized design for an Elliptic Curve Cryptosystem Coprocessor,” in *Proceedings of the International Conference on Information Technology: Coding and Computing (ITCC05)*, IEEE, 0–7695–2315–3/05.
- [6] Goswami Sukalyan, Laha Subarna, Chakraborty Satarupa, Dhar Ankana, “Enhancement of GSM Security Using Elliptic Curve Cryptography Algorithm,” in *Third International Conference on Intelligent Systems Modelling and Simulation*, DOI 10.1109/ISMS.2012.137.
- [7] McIvor J. Ciaran, McLoone Maire, McCanny V. John, “Hardware Elliptic Curve Cryptographic Processor Over GF(p),” in *IEEE Transactions on Circuits and Systems-I*, vol. 53, No. 9, pp. 1051–7122, 2006.
- [8] Fan Junfeng, Sakiyama Kazuo and Verbauwhede Ingrid, “Elliptic curve cryptography on embedded multicore systems,” in *Journal on Design Automation for Embedded Systems*, vol. 12, pp.231–242, 2008.
- [9] Abdurahmonov Tursun, Yeoh Eng-Thiam and Mohamed Hussain Helmi, “Improving Smart Card Security Using Elliptic Curve Cryptography over Prime Field (F_p),” in *Artificial Intelligence, NPD*, SCI 368, pp.127–140, 2011.
- [10] “MicroBlaze Processor Reference Guide, Embedded Development Kit EDK 10.1i,” in, http://www.xilinx.com/support/documentation/sw_manuals/mb_ref_guide.pdf.
- [11] William Wong, “Baisc of design,Embedded Processor,” <http://electronicdesign.com/embedded/embedded-processors>
- [12] Vasanth Asokan., “Designing Multiprocessor Systems in Platform Studio,” in *White Paper: Xilinx Platform Studio (XPS)*, http://www.xilinx.com/support/documentation/white_papers/wp262.pdf.
- [13] “XAPP996,Xilinx application note on Dual Processor,” in, http://www.xilinx.com/support/documentation/application_notes/xapp996.pdf.

Authors' Instructions for the Preparation of Camera-Ready Manuscript to Elsevier Proceedings

Venugopal K R^{a,1,*}, L M Patnaik^{b,2}

^a*University Visvesvaraya College of Engineering, Bangalore University, Bangalore.*

^b*Honorary Professor, Indian Institute of Science, Bangalore.*

Abstract

The abstract should summarize the contents of the paper and should contain at least 70 and at most 150 words. It should be written using the *abstract* environment.

Keywords: We would like to encourage you to list your keywords within the abstract section.

1. Introduction

You are strongly encouraged to use L^AT_EX for the preparation of your camera-ready manuscript together with the corresponding Elsevier style file. The L^AT_EX source of this instruction file for L^AT_EX users may be used as a template. This is located in the *Guidelines for authors* link in elsevier.com link. Kindly send the final checked source and PDF files of your paper to the Contact Volume Editor. This is usually one of the organizers of the conference. Make sure that the L^AT_EX and the PDF files are identical and correct and that only one version of your paper is sent. Since it is impossible to update files at a later stage. Please do not send the printed paper.

The papers once published cannot be updated or changed at any cost. This applies to both the printed book and the online version of the publication. Every detail, including the order of the names of the authors, should be checked before the paper is sent to the Volume Editors.

*Corresponding author

URL: <http://www.venugopalkr.com> (Venugopal K R)

¹Principal, University Visvesvaraya College of Engineering, Bangalore.

²Honorary Professor, Indian Institute of Science, Bangalore.

1.1. Checking the PDF File

Kindly assure that the Contact Volume Editor is given the name and email address of the contact author for your paper.

In some cases, it is the Contact Volume Editor that checks all the final pdfs. In such cases, the authors are not involved in the checking phase.

1.2. Additional Information Required by the Volume Editor

If you have more than one surname, please make sure that the Volume Editor knows how you are to be listed in the author index.

1.3. Copyright Forms

The copyright form may be downloaded from the *For Authors* section of the Elsevier Website: www.elsevier.com. Please send your signed copyright form to the Contact Volume Editor as a scanned pdf. One author may sign on behalf of all of the other authors of a particular paper.

2. Floats

Figures may be included using the command, `includegraphics` in combination with or without its several options to further control graphic. `includegraphics` is provided by `graphic[s,x].sty` which is part of any standard LATEX distribution. A `graphicx.sty` is loaded by default. LATEX accepts figures in postscript format while A pdfLATEX.

AT X accepts *.pdf, *.mps (metapost), *.jpg and *.png formats. pdfLATEX does not accept graphic files in postscript format.

The table environment is handy for marking up tabular material. If users want to use `multirow.sty`, `array.sty`, etc., to fine control/enhance the tables, they are welcome to load any package of their choice and `elsarticle.cls` will work in combination with all loaded packages.

2.0.1. Headings.

Headings should be capitalized (i.e., nouns, verbs, and all other words except articles, prepositions, and conjunctions should be set with an initial capital) and should, with the exception of the title, be aligned to the left. Words joined by a hyphen are subject to a special rule. If the first word can stand alone, the second word should be capitalized.

2.0.2. Lemmas, Propositions, and Theorems.

The numbers accorded to lemmas, propositions, and theorems, etc. should appear in consecutive order, starting with Lemma 1, and not, for example, with Lemma 11.

2.1. Figures

For L^AT_EX users, we recommend using the *graphics* or *graphicx* package.

Please check that the lines in line drawings are not interrupted and are of a constant width. Grids and details within the figures must be clearly legible and may not be written one on top of the other. Line drawings should have a resolution of at least 800 dpi (preferably 1200 dpi). The lettering in figures should have a height of 2 mm (10-point type). Figures should be numbered and should have a caption which should always be positioned *under* the figures, in contrast to the caption belonging to a table, which should always appear *above* the table; this is simply achieved as matter of sequence in your source.

Please center the figures or your tabular material. Short captions are centered by default between the margins and typeset in 9-point type. The distance between text and figure is preset to be about 8 mm, the distance between figure and caption about 6 mm.

To ensure that the reproduction of your illustrations is of a reasonable quality, we advise against the use of shading. The contrast should be as pronounced as possible.

If screenshots are necessary, please make sure that you are happy with the print quality before you send the files.

Use the format to generate the Figure 1.

2.2. Itemization

- (i) Find maximum number of keymatches between the communicating nodes.
- (ii) Choosing a secure path based on the Link Strength.

2.3. Table

The notations used in this paper are given in Table 1.

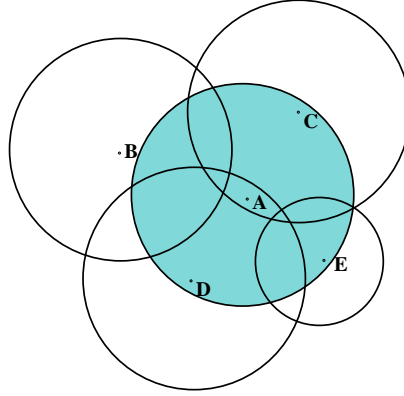

Figure 1: Connectivity of Sleep Nodes.

Table 1: **Notations**

<i>Symbols</i>	<i>Definition</i>
dst	Destination Node
src	Source Node
$Rnd()$	Pseudo Random Generating Function
K_r	Maximum possible value that is generated

2.4. Formulas

Displayed equations or formulas are centered and set on a separate line (with an extra line or halfline space above and below). Displayed expressions should be numbered for reference. The numbers should be consecutive within each section or within the contribution, with numbers enclosed in parentheses and set on the right margin –which is the default if you use the *equation* environment, e.g.,

$$\binom{P}{m} = \frac{P!}{m!(P-m)!} \quad (1)$$

Equations should be punctuated in the same way as ordinary text but with a small space before the end punctuation mark.

2.5. Footnotes

The superscript numeral used to refer to a footnote appears in the text either directly after the word to be discussed or – in relation to a phrase or a sentence – following the punctuation sign (comma, semicolon, or period).

Table 2: Algorithm: Secure QoS-Aware Data Fusion (SQDF)

<pre><i>First Phase</i> begin Send Data Packet end <i>Second Phase</i> begin Receive Data Packet if(malicious node) Reset the timer else Reset the timer for deffer time Fuses data end</pre>
--

Footnotes should appear at the bottom of the normal text area, with a line of about 2 cm set immediately above them.³

2.6. Citations

For citations in the text please use square brackets and consecutive numbers: [1], [2], [3] – provided automatically by L^AT_EX.

2.7. Page Numbering and Running Heads

There is no need to include page numbers. If your paper title is too long it will be shortened.

2.8. Algorithm

Place the algorithm within a box as shown in Table 2.

3. Graphs

The graphs are shown in Figure 2 and Figure 3.

³The footnote numeral is set flush left and the text follows with the usual word spacing.

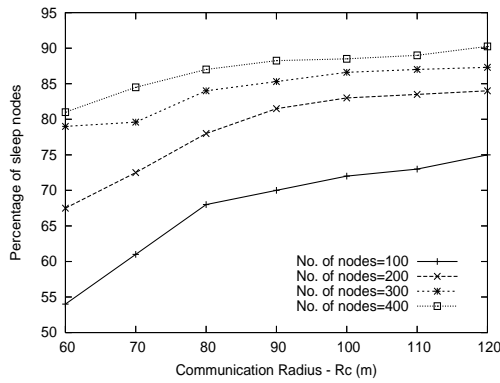

Figure 2: Percentage of Sleep Nodes.

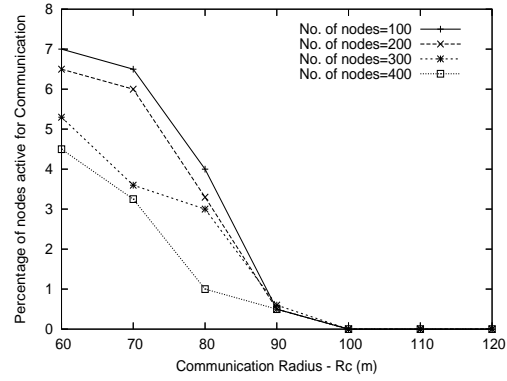

Figure 3: Percentage of Communication Unit Active Nodes.

4. Conclusions

Check List before submission of the final manuscript.

- The final \LaTeX source files
- A final PDF file
- A copyright form, signed by one author on behalf of all of the authors of the paper.
- A readme giving the name and email address of the corresponding author.

Appendix

If any mathematical derivations or theoretical concepts are existing, include in the Appendix.

Acknowledgments.

The previous work authors can be appreciated or the funding agencies can be acknowledged.

5. The References Section

In order to permit cross referencing standardizing format has to be used in the references. References that don't adhere to this style will be reformatted by Elsevier. You should therefore check your references thoroughly when you receive the final pdf of your paper. The reference section must be complete. You may not omit references.

The following section shows a sample reference list with entries for proceedings without editors [1], journal articles [2], transactions [3], a book [4], URL [5].

References

- [1] F. L. Lewis, D. J. Cook, S. K. Dasm and John Wiley, "Wireless Sensor Networks," in *Proceedings Smart Environment Technologies, Protocols and Applications, New York*, 2004, pp. 1–18.
- [2] Kui Ren, Kai Zeng and Wenjing Lou, "A New Approach for Random Key Pre-distribution in Large-Scale Wireless Sensor Networks," in *Journal on Wireless Communications and Mobile Computing*, vol. 6, pp. 307–318, 2006.
- [3] Chia-Mu Yu, Chun-Shien Lu and Sy-Yen Kuo, "Noninteractive Pairwise Key Establishment for Wireless Sensor Networks," in *IEEE Transactions on Information Forensics and Security*, vol. 5, no. 3, pp. 556–569, 2010.
- [4] Raj Jain, "Art of Computer System Performance Analysis," in *Wiley India Pvt. Ltd*, 2009, pp. 198–200.
- [5] [http : //www.statcac.com/statistics/correlation – regression](http://www.statcac.com/statistics/correlation-regression).