

P4: Programming Protocol-Independent Packet Processors

Pat Bosshart[†], Dan Daly^{*}, Glen Gibb[†], Martin Izzard[†], Nick McKeown[‡], Jennifer Rexford^{**}, Cole Schlesinger^{**}, Dan Talayco[†], Amin Vahdat[¶], George Varghese[§], David Walker^{**}
[†]Barefoot Networks ^{*}Intel [‡]Stanford University ^{**}Princeton University [¶]Google [§]Microsoft Research

ABSTRACT

P4 is a high-level language for programming protocol-independent packet processors. P4 works in conjunction with SDN control protocols like OpenFlow. In its current form, OpenFlow explicitly specifies protocol headers on which it operates. This set has grown from 12 to 41 fields in a few years, increasing the complexity of the specification while still not providing the flexibility to add new headers. In this paper we propose P4 as a strawman proposal for how OpenFlow should evolve in the future. We have three goals: (1) Reconfigurability in the field: Programmers should be able to change the way switches process packets once they are deployed. (2) Protocol independence: Switches should not be tied to any specific network protocols. (3) Target independence: Programmers should be able to describe packet-processing functionality independently of the specifics of the underlying hardware. As an example, we describe how to use P4 to configure a switch to add a new hierarchical label.

1. INTRODUCTION

Software-Defined Networking (SDN) gives operators programmatic control over their networks. In SDN, the control plane is physically separate from the forwarding plane, and one control plane controls multiple forwarding devices. While forwarding devices could be programmed in many ways, having a common, open, vendor-agnostic interface (like OpenFlow) enables a control plane to control forwarding devices from different hardware and software vendors.

Version	Date	Header Fields
OF 1.0	Dec 2009	12 fields (Ethernet, TCP/IPv4)
OF 1.1	Feb 2011	15 fields (MPLS, inter-table metadata)
OF 1.2	Dec 2011	36 fields (ARP, ICMP, IPv6, etc.)
OF 1.3	Jun 2012	40 fields
OF 1.4	Oct 2013	41 fields

Table 1: Fields recognized by the OpenFlow standard

The OpenFlow interface started simple, with the abstraction of a single table of rules that could match packets on a dozen header fields (e.g., MAC addresses, IP addresses, protocol, TCP/UDP port numbers, etc.). Over the past five years, the specification has grown increasingly more complicated (see Table 1), with many more header fields and

multiple stages of rule tables, to allow switches to expose more of their capabilities to the controller.

The proliferation of new header fields shows no signs of stopping. For example, data-center network operators increasingly want to apply new forms of packet encapsulation (e.g., NVGRE, VXLAN, and STT), for which they resort to deploying software switches that are easier to extend with new functionality. Rather than repeatedly extending the OpenFlow specification, we argue that future switches should support flexible mechanisms for parsing packets and matching header fields, allowing controller applications to leverage these capabilities through a common, open interface (i.e., a new “OpenFlow 2.0” API). Such a general, extensible approach would be simpler, more elegant, and more future-proof than today’s OpenFlow 1.x standard.

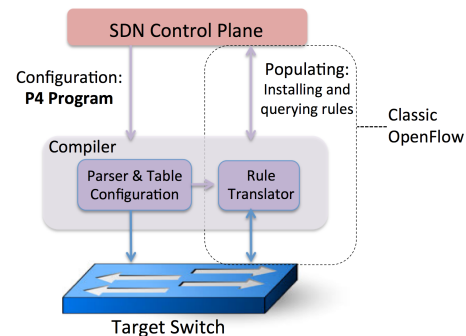

Figure 1: P4 is a language to configure switches.

Recent chip designs demonstrate that such flexibility can be achieved in custom ASICs at terabit speeds [1, 2, 3]. Programming this new generation of switch chips is far from easy. Each chip has its own low-level interface, akin to microcode programming. In this paper, we sketch the design of a higher-level language for Programming Protocol-independent Packet Processors (P4). Figure 1 shows the relationship between P4—used to configure a switch, telling it how packets are to be processed—and existing APIs (such as OpenFlow) that are designed to populate the forwarding tables in fixed function switches. P4 raises the level of abstraction for programming the network, and can serve as a

general interface between the controller and the switches. That is, we believe that future generations of OpenFlow should allow the controller to *tell the switch how to operate*, rather than be constrained by a fixed switch design. The key challenge is to find a “sweet spot” that balances the need for expressiveness with the ease of implementation across a wide range of hardware and software switches. In designing P4, we have three main goals:

- **Reconfigurability.** The controller should be able to re-define the packet parsing and processing in the field.
- **Protocol independence.** The switch should not be tied to specific packet formats. Instead, the controller should be able to specify (i) a packet parser for extracting header fields with particular names and types and (ii) a collection of typed match+action tables that process these headers.
- **Target independence.** Just as a C programmer does not need to know the specifics of the underlying CPU, the controller programmer should not need to know the details of the underlying switch. Instead, a compiler should take the switch’s capabilities into account when turning a target-independent description (written in P4) into a target-*dependent* program (used to configure the switch).

The outline of the paper is as follows. We begin by introducing an abstract switch forwarding model. Next, we explain the need for a new language to describe protocol-independent packet processing. We then present a simple motivating example where a network operator wants to support a new packet-header field and process packets in multiple stages. We use this to explore how the P4 program specifies headers, the packet parser, the multiple match+action tables, and the control flow through these tables. Finally, we discuss how a compiler can map P4 programs to target switches.

Related work. In 2011, Yadav et al. [4] proposed an abstract forwarding model for OpenFlow, but with less emphasis on a compiler. Kangaroo [1] introduced the notion of programmable parsing. Recently, Song [5] proposed protocol-oblivious forwarding which shares our goal of protocol independence, but is targeted more towards network processors. The ONF introduced table typing patterns to express the matching capabilities of switches [6]. Recent work on NOSIX [7] shares our goal of flexible specification of match+action tables, but does not consider protocol-independence or propose a language for specifying the parser, tables, and control flow. Other recent work proposes a programmatic interface to the data plane for monitoring, congestion control, and queue management [8, 9]. The Click modular router [10] supports flexible packet processing in software, but does not map programs to a variety of target hardware switches.

2. ABSTRACT FORWARDING MODEL

In our abstract model (Fig. 2), switches forward packets via a programmable parser followed by multiple stages of match+action, arranged in series, parallel, or a combination of both. Derived from OpenFlow, our model makes three

generalizations. First, OpenFlow assumes a fixed parser, whereas our model supports a programmable parser to allow new headers to be defined. Second, OpenFlow assumes the match+action stages are in series, whereas in our model they can be in parallel or in series. Third, our model assumes that actions are composed from protocol-independent primitives supported by the switch.

Our abstract model generalizes how packets are processed in different forwarding devices (e.g., Ethernet switches, routers, load-balancers) and by different technologies (e.g., fixed-function switch ASICs, NPUs, reconfigurable switches, software switches, FPGAs). This allows us to devise a common language (P4) to represent how packets are processed in terms of our common abstract model. Hence, programmers can create target-independent programs that a compiler can map to a variety of different forwarding devices, ranging from relatively slow software switches to the fastest ASIC-based switches.

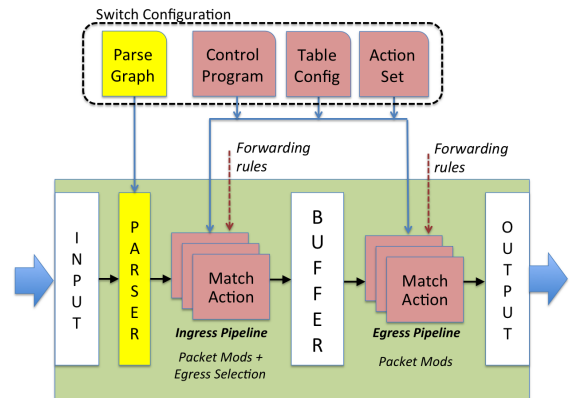

Figure 2: The abstract forwarding model.

The forwarding model is controlled by two types of operations: Configure and Populate. *Configure* operations program the parser, set the order of match+action stages, and specify the header fields processed by each stage. Configuration determines which protocols are supported and how the switch may process packets. *Populate* operations add (and remove) entries to the match+action tables that were specified during configuration. Population determines the policy applied to packets at any given time.

For the purposes of this paper, we assume that configuration and population are two distinct phases. In particular, the switch need not process packets during configuration. However, we expect implementations will allow packet processing during partial or full reconfiguration enabling upgrades with no downtime. Our model deliberately allows for, and encourages, reconfiguration that does not interrupt forwarding.

Clearly, the configuration phase has little meaning in fixed-function ASIC switches; for this type of switch, the com-

piler’s job is to simply check if the chip can support the P4 program. Instead, our goal is to capture the general trend towards fast reconfigurable packet-processing pipelines, as described in [2, 3].

Arriving packets are first handled by the parser. The packet body is assumed to be buffered separately, and unavailable for matching. The parser recognizes and extracts fields from the header, and thus defines the protocols supported by the switch. The model makes no assumptions about the meaning of protocol headers, only that the parsed representation defines a collection of fields on which matching and actions operate.

The extracted header fields are then passed to the match+action tables. The match+action tables are divided between ingress and egress. While both may modify the packet header, ingress match+action determines the egress port(s) and determines the queue into which the packet is placed. Based on ingress processing, the packet may be forwarded, replicated (for multicast, span, or to the control plane), dropped, or trigger flow control. Egress match+action performs per-instance modifications to the packet header – e.g., for multicast copies. Action tables (counters, policers, etc.) can be associated with a flow to track frame-to-frame state.

Packets can carry additional information between stages, called *metadata*, which is treated identically to packet header fields. Some examples of metadata include the ingress port, the transmit destination and queue, a timestamp that can be used for packet scheduling, and data passed from table-to-table that does not involve changing the parsed representation of the packet such as a virtual network identifier.

Queueing disciplines are handled in the same way as the current OpenFlow: an action maps a packet to a queue, which is configured to receive a particular service discipline. The service discipline (e.g., minimum rate, DRR) is chosen as part of the switch configuration.

Although beyond the scope of this paper, action primitives can be added to allow the programmer to implement new or existing congestion control protocols. For example, the switch might be programmed to set the ECN bit based on novel conditions, or it might implement a proprietary congestion control mechanism using match+action tables.

3. A PROGRAMMING LANGUAGE

We use the abstract forwarding model to define a language to express how a switch is to be configured and how packets are to be processed. This paper’s main goal is to propose the P4 programming language. However, we recognize that many languages are possible, and they will likely share the common characteristics we describe here. For example, the language needs a way to express how the parser is programmed so that the parser knows what packet formats to expect; hence a programmer needs a way to declare what header types are possible. As an example, the programmer could specify the format of an IPv4 header and what headers may legally follow the IP header. This motivates defining

parsing in P4 by declaring legal header types. Similarly, the programmer needs to express how packet headers are to be processed. For example, TTL fields must be decremented and tested, new tunnel headers may need to be added, and checksums may need to be computed. This motivates P4’s use of an imperative control flow program to describe header field processing using the declared header types and a primitive set of actions.

We could use a language such as Click [10], which builds switches from modules composed of arbitrary C++. Click is extremely expressive, and very suitable for expressing how packets are processed in the kernel of a CPU. But it is insufficiently constrained for our needs—we need a language that mirrors the parse-match-action pipelines in dedicated hardware. In addition, Click is not designed for a controller-switch architecture and hence does not allow programmers to describe match+action tables that are dynamically populated by well-typed rules. Finally, Click makes it difficult to infer dependencies that constrain parallel execution—as we now discuss.

A packet processing language must allow the programmer to express (implicitly or explicitly) any serial dependencies between header fields. Dependencies determine which tables can be executed in parallel. For example, sequential execution is required for an IP routing table and an ARP table due to the data dependency between them. Dependencies can be identified by analyzing *Table Dependency Graphs* (TDGs); these graphs describe the field inputs, actions, and control flow between tables. Figure 3 shows an example table dependency graph for an L2/L3 switch. TDG nodes map directly to match+action tables, and a dependency analysis identifies where each table may reside in the pipeline. Unfortunately TDGs are not readily accessible to most programmers; programmers tend to think of packet processing algorithms using imperative constructs rather than graphs.

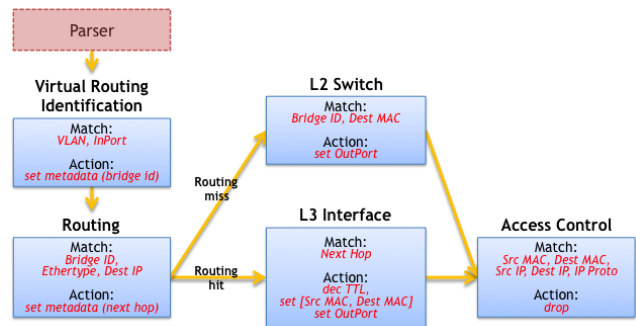

Figure 3: Table dependency graph for an L2/L3 switch.

This leads us to propose a two-step compilation process. At the highest level, programmers express packet processing programs using an imperative language representing the control flow (P4); below this, a compiler translates the P4 representation to TDGs to facilitate dependency analysis,

and then maps the TDG to a specific switch target. P4 is designed to make it easy to translate a P4 program into a TDG. In summary, P4 can be considered to be a sweet spot between the generality of say Click (that makes it difficult to infer dependencies and map to hardware) and the inflexibility of OpenFlow 1.0 (that makes it impossible to reconfigure protocol processing).

4. P4 LANGUAGE BY EXAMPLE

We explore P4 by examining a simple example in-depth. Many network deployments differentiate between an edge and a core; end-hosts are directly connected to edge devices, which are in turn interconnected by a high-bandwidth core. Entire protocols have been designed to support this architecture (such as MPLS [11] and PortLand [12]), aimed primarily at simplifying forwarding in the core.

Consider an example L2 network deployment with top-of-rack (ToR) switches at the edge connected by a two-tier core. We will assume the number of end-hosts is growing and the core L2 tables are overflowing. MPLS is an option to simplify the core, but implementing a label distribution protocol with multiple tags is a daunting task. PortLand looks interesting but requires rewriting MAC addresses—possibly breaking existing network debugging tools—and requires new agents to respond to ARP requests.

P4 lets us express a custom solution with minimal changes to the network architecture. We call our toy example *mTag*: it combines the hierarchical routing of PortLand with simple MPLS-like tags. The routes through the core are encoded by a 32-bit tag composed of four single-byte fields. The 32-bit tag can carry a “source route” or a destination locator (like PortLand’s Pseudo MAC). Each core switch need only examine one byte of the tag and switch on that information. In our example, the tag is added by the first ToR switch, although it could also be added by the end-host NIC.

The *mTag* example is intentionally very simple to focus our attention on the P4 language. The P4 program for an entire switch would be many times more complex in practice.

4.1 P4 Concepts

A P4 program contains definitions of the following key components:

- **Headers:** A header definition describes the sequence and structure of a series of fields. It includes specification of field widths and constraints on field values.
- **Parsers:** A parser definition specifies how to identify headers and valid header sequences within packets.
- **Tables:** Match+action tables are the mechanism for performing packet processing. The P4 program defines the fields on which a table may match and the actions it may execute.
- **Actions:** P4 supports construction of complex actions from simpler protocol-independent primitives. These complex actions are available within match+action tables.
- **Control Programs:** The control program determines

the order of match+action tables that are applied to a packet. A simple imperative program describe the flow of control between match+action tables.

Next, we show how each of these components contributes to the definition of an idealized *mTag* processor in P4.

4.2 Header Formats

A design begins with the specification of header formats. Several domain-specific languages have been proposed for this [13, 14, 15]; P4 borrows a number of ideas from them. In general, each header is specified by declaring an ordered list of field names together with their widths. Optional field annotations allow constraints on value ranges or maximum lengths for variable-sized fields. For example, standard Ethernet and VLAN headers are specified as follows:

```
header ethernet {
    fields {
        dst_addr : 48; // width in bits
        src_addr : 48;
        ethertype : 16;
    }
}

header vlan {
    fields {
        pcp : 3;
        cfi : 1;
        vid : 12;
        ethertype : 16;
    }
}
```

The *mTag* header can be added without altering existing declarations. The field names indicate that the core has two layers of aggregation. Each core switch is programmed with rules to examine one of these bytes determined by its location in the hierarchy and the direction of travel (up or down).

```
header mTag {
    fields {
        up1 : 8;
        up2 : 8;
        down1 : 8;
        down2 : 8;
        ethertype : 16;
    }
}
```

4.3 The Packet Parser

P4 assumes the underlying switch can implement a state machine that traverses packet headers from start to finish, extracting field values as it goes. The extracted field values are sent to the match+action tables for processing.

P4 describes this state machine directly as the set of transitions from one header to the next. Each transition may be triggered by values in the current header. For example, we describe the *mTag* state machine as follows.

```
parser start{
```

```

    ethernet;
}

parser ethernet {
    switch(ethertype) {
        case 0x8100: vlan;
        case 0x9100: vlan;
        case 0x800: ipv4;
        // Other cases
    }
}

parser vlan {
    switch(ethertype) {
        case 0xaaaa: mTag;
        case 0x800: ipv4;
        // Other cases
    }
}

parser mTag {
    switch(ethertype) {
        case 0x800: ipv4;
        // Other cases
    }
}

```

Parsing starts in the `start` state and proceeds until an explicit `stop` state is reached or an unhandled case is encountered (which may be marked as an error). Upon reaching a state for a new header, the state machine extracts the header using its specification and proceeds to identify its next transition. The extracted headers are forwarded to match+action processing in the back-half of the switch pipeline.

The parser for *mTag* is very simple: it has only four states. Parsers in real networks require many more states; for example, the parser defined by Gibb *et. al.* [16, Figure 3(e)] expands to over one hundred states.

4.4 Table Specification

Next, the programmer describes how the defined header fields are to be matched in the match+action stages (e.g., should they be exact matches, ranges, or wildcards?) and what actions should be performed when a match occurs.

In our simple *mTag* example, the edge switch matches on the L2 destination and VLAN ID, and selects an *mTag* to add to the header. The programmer defines a table to match on these fields and apply an action to add the *mTag* header (see below). The `reads` attribute declares which fields to match, qualified by the match type (exact, ternary, etc). The `actions` attribute lists the possible actions which may be applied to a packet by the table. Actions are explained in the following section. The `max_size` attribute specifies how many entries the table should support.

The table specification allows a compiler to decide how much memory it needs, and the memory type (e.g., TCAM or SRAM) to implement the table.

```
table mTag_table {
```

```

    reads {
        ethernet.dst_addr : exact;
        vlan.vid : exact;
    }
    actions {
        // At runtime, entries are programmed with params
        // for the mTag action. See below.
        add_mTag;
    }
    max_size : 20000;
}

```

For completeness and for later discussion, we present brief definitions of other tables that are referenced by the Control Program (§4.6).

```

table source_check {
    // Verify mtag only on ports to the core
    reads {
        mtag : valid; // Was mtag parsed?
        metadata.ingress_port : exact;
    }
    actions { // Each table entry specifies *one* action

        // If inappropriate mTag, send to CPU
        fault_to_cpu;

        // If mtag found, strip and record in metadata
        strip_mtag;

        // Otherwise, allow the packet to continue
        pass;
    }
    max_size : 64; // One rule per port
}

table local_switching {
    // Reads destination and checks if local
    // If miss occurs, goto mtag table.
}

table egress_check {
    // Verify egress is resolved
    // Do not retag packets received with tag
    // Reads egress and whether packet was mTagged
}

```

4.5 Action Specifications

P4 defines a collection of primitive actions from which more complicated actions are built. Each P4 program declares a set of action functions that are composed of action primitives; these action functions simplify table specification and population. P4 assumes parallel execution of primitives within an action function. (Switches incapable of parallel execution may emulate the semantics.)

The `add_mTag` action referred to above is implemented as follows:

```

action add_mTag(up1, up2, down1, down2, egr_spec) {
    add_header(mTag);
    // Copy VLAN ethertype to mTag
    copy_field(mTag.ethertype, vlan.ethertype);
}

```

```

// Set VLAN's ethertype to signal mTag
set_field(vlan.ethertype, 0xaaaa);
set_field(mTag.up1, up1);
set_field(mTag.up2, up2);
set_field(mTag.down1, down1);
set_field(mTag.down2, down2);

// Set the destination egress port as well
set_field(metadata.egress_spec, egr_spec);
}

```

If an action needs parameters (e.g., the `up1` value for the `mTag`), it is supplied from the match table at runtime.

In this example, the switch inserts the `mTag` after the VLAN tag, copies the VLAN tag's ethertype into the `mTag` to indicate what follows, and sets the VLAN tag's ethertype to `0xaaaa` to signal `mTag`. Not shown are the inverse action specification that strips an `mTag` from a packet and the table to apply this action in edge switches.

P4's primitive actions include:

- **set_field**: Set a specific field in a header to a value. Masked sets are supported.
- **copy_field**: Copy one field to another.
- **add_header**: Set a specific header instance (and all its fields) as valid.
- **remove_header**: Delete (“pop”) a header (and all its fields) from a packet.
- **increment**: Increment or decrement the value in a field.
- **checksum**: Calculate a checksum over some set of header fields (e.g., an IPv4 checksum).

We expect most switch implementations will restrict action processing to permit only header modifications that are consistent with the specified packet format.

4.6 The Control Program

Once tables and actions are defined, the only remaining task is to specify the flow of control from one table to the next. Control flow is specified as a program via a collection of functions, conditionals, and table references.

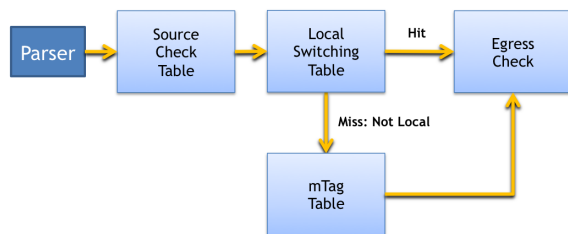

Figure 4: Flow chart for the `mTag` example.

Figure 4 shows a graphical representation of the desired control flow for the `mTag` implementation on edge switches. After parsing, the `source_check` table verifies consistency between the received packet and the ingress port. For example, `mTags` should only be seen on ports connected to core switches. The `source_check` also strips `mTags` from the packet, recording whether the packet had an `mTag` in

metadata. Tables later in the pipeline may match on this metadata to avoid retagging the packet.

The `local_switching` table is then executed. If this table “misses,” it indicates that the packet is not destined for a locally connected host. In that case, the `mTag_table` (defined above) is applied to the packet. Both local and core forwarding control can be processed by the `egress_check` table which handles the case of an unknown destination by sending a notification up the SDN control stack.

The imperative representation of this packet processing pipeline is as follows:

```

control main() {
    // Verify mTag state and port are consistent
    table(source_check);

    // If no error from source_check, continue
    if (!defined(metadata.ingress_error)) {
        // Attempt to switch to end hosts
        table(local_switching);

        if (!defined(metadata.egress_spec)) {
            // Not a known local host; try mtagging
            table(mTag_table);
        }

        // Check for unknown egress state or
        // bad retagging with mTag.
        table(egress_check);
    }
}

```

5. COMPILING A P4 PROGRAM

For a network to implement our P4 program, we need a compiler to map the target-independent description onto the target switch's specific hardware or software platform. Doing so involves allocating the target's resources and generating appropriate configuration for the device.

5.1 Compiling Packet Parsers

For devices with *programmable* parsers, the compiler translates the parser description into a parsing state machine, while for fixed parsers, the compiler merely verifies that the parser description is consistent with the target's parser. Details of generating a state machine and state table entries can be found in [16].

Table 2 shows state table entries for the `vlan` and `mTag` sections of the parser (§4.3). Each entry specifies the current state, the field value to match, and the next state. Other columns are omitted for brevity.

Current State	Lookup Value	Next State
<code>vlan</code>	<code>0xaaaa</code>	<code>mTag</code>
<code>vlan</code>	<code>0x800</code>	<code>ipv4</code>
<code>vlan</code>	<code>*</code>	<code>stop</code>
<code>mTag</code>	<code>0x800</code>	<code>ipv4</code>
<code>mTag</code>	<code>*</code>	<code>stop</code>

Table 2: Parser state table entries for the `mTag` example.

5.2 Compiling Control Programs

The imperative control-flow representation in §4.6 is a convenient way to specify the logical forwarding behavior of a switch, but does not explicitly call out dependencies between tables or opportunities for concurrency. We therefore employ a compiler to analyze the control program to identify dependencies and look for opportunities to process header fields in parallel. Finally, the compiler generates the target configuration for the switch. There are many potential targets: for example, a software switch [17], a multicore software switch [18], an NPU [19], a fixed function switch [20], or a reconfigurable match table (RMT) pipeline [2].

As discussed in §3, the compiler follows a two-stage compilation process. It first converts the P4 control program into an intermediate *table dependency graph* representation which it analyzes to determine dependencies between tables. A target-specific back-end then maps this graph onto the switch’s specific resources.

We briefly examine how the *mTag* example would be implemented in different kinds of switches:

Software switches: A software switch provides complete flexibility: the table count, table configuration, and parsing are under software control. The compiler directly maps the mTag table graph to switch tables. The compiler uses table type information to constrain table widths, heights, and matching criterion (e.g., exact, prefix, or wildcard) of each table. The compiler might also optimize ternary or prefix matching with software data structures.

Hardware switches with RAM and TCAM: A compiler can configure hashing to perform efficient exact-matching using RAM, for the `mTag_table` in edge switches. In contrast, the core mTag forwarding table that matches on a subset of tag bits would be mapped to TCAM.

Switches supporting parallel tables: The compiler can detect data dependencies and arrange tables in parallel or in series. In the mTag example, the tables `local_switching` and `mTag_table` can execute in parallel up to the execution of the action of setting an mTag.

Switches that apply actions at the end of the pipeline: For switches with action processing only at the end of a pipeline, the compiler can tell intermediate stages to generate metadata that is used to perform the final writes. In the mTag example, whether the mTag is added or removed could be represented in metadata.

Switches with a few tables: The compiler can map a large number of P4 tables to a smaller number of physical tables. In the mTag example, the local switching could be combined with the mTag table. When the controller installs new rules at runtime, the compiler’s rule translator can “compose” the rules in the two P4 tables to generate the rules for the single physical table.

6. CONCLUSION

The promise of SDN is that a single control plane can di-

rectly control a whole network of switches. OpenFlow supports this goal by providing a single, vendor-agnostic API. However, today’s OpenFlow targets *fixed*-function switches that recognize a pre-determined set of header fields and that process packets using a small set of predefined actions. The control plane cannot express how packets *should* be processed to best meet the needs of control applications.

We propose a step towards more flexible switches whose functionality is specified—and may be changed—in the field. The programmer decides how the forwarding plane processes packets without worrying about implementation details. A compiler transforms an imperative program into a table dependency graph that can be mapped to many specific target switches, including optimized hardware implementations.

We emphasize that this is only a first step, designed as a straw-man proposal for OpenFlow 2.0 to contribute to the debate. In this proposal, several aspects of a switch remain undefined (e.g., congestion-control primitives, queuing disciplines, traffic monitoring). However, we believe the approach of having a configuration language—and compilers that generate low-level configurations for specific targets—will lead to future switches that provide greater flexibility, and unlock the potential of software defined networks.

7. REFERENCES

- [1] C. Kozanitis, J. Huber, S. Singh, and G. Varghese, “Leaping multiple headers in a single bound: Wire-speed parsing using the Kangaroo system,” in *IEEE INFOCOM*, pp. 830–838, 2010.
- [2] P. Bosshart, G. Gibb, H.-S. Kim, G. Varghese, N. McKeown, M. Izzard, F. Mujica, and M. Horowitz, “Forwarding metamorphosis: Fast programmable match-action processing in hardware for SDN,” in *ACM SIGCOMM*, 2013.
- [3] “Intel Ethernet Switch Silicon FM6000.” <http://www.intel.com/content/dam/www/public/us/en/documents/white-papers/ethernet-switch-fm6000-sdn-paper.pdf>.
- [4] N. Yadav and D. Cohn, “OpenFlow Primitive Set.” <http://goo.gl/6qwbq>, July 2011.
- [5] H. Song, “Protocol-oblivious forwarding: Unleash the power of SDN through a future-proof forwarding plane,” in *SIGCOMM HotSDN Workshop*, Aug. 2013.
- [6] “Openflow forwarding abstractions working group charter.” <http://goo.gl/TtLtw0>, Apr. 2013.
- [7] M. Raju, A. Wundsam, and M. Yu, “NOSIX: A lightweight portability layer for the SDN OS,” *ACM SIGCOMM Computer Communications Review*, 2014.
- [8] V. Jeyakumar, M. Alizadeh, C. Kim, and D. Mazieres, “Tiny packet programs for low-latency network control and monitoring,” in *ACM SIGCOMM HotNets Workshop*, Nov. 2013.
- [9] A. Sivaraman, K. Winstein, S. Subramanian, and H. Balakrishnan, “No silver bullet: Extending SDN to

- the data plane,” in *ACM SIGCOMM HotNets Workshop*, Nov. 2013.
- [10] E. Kohler, R. Morris, B. Chen, J. Jannotti, and M. F. Kaashoek, “The Click modular router,” *ACM Transactions on Computer Systems*, vol. 18, pp. 263–297, Aug. 2000.
- [11] “Multiprotocol Label Switching Charter.” <http://datatracker.ietf.org/wg/mpls/charter/>.
- [12] R. Niranjan Mysore, A. Pamboris, N. Farrington, N. Huang, P. Miri, S. Radhakrishnan, V. Subramanya, and A. Vahdat, “PortLand: A scalable fault-tolerant layer 2 data center network fabric,” in *ACM SIGCOMM*, pp. 39–50, Aug. 2009.
- [13] P. McCann and S. Chandra, “PacketTypes: Abstract specification of network protocol messages,” in *ACM SIGCOMM*, pp. 321–333, Aug. 2000.
- [14] G. Back, “DataScript - A specification and scripting language for binary data,” in *Generative Programming and Component Engineering*, vol. 2487, pp. 66–77, Lecture Notes in Computer Science, 2002.
- [15] K. Fisher and R. Gruber, “PADS: A domain specific language for processing ad hoc data,” in *ACM Conference on Programming Language Design and Implementation*, pp. 295–304, June 2005.
- [16] G. Gibb, G. Varghese, M. Horowitz, and N. McKeown, “Design principles for packet parsers,” in *ANCS*, pp. 13–24, 2013.
- [17] “Open vSwitch website.” <http://www.openvswitch.org>.
- [18] D. Zhou, B. Fan, H. Lim, M. Kaminsky, and D. G. Andersen, “Scalable, high performance ethernet forwarding with CuckooSwitch,” in *CoNext*, pp. 97–108, 2013.
- [19] “EZChip 240-Gigabit Network Processor for Carrier Ethernet Applications.” http://www.ezchip.com/p_np5.htm.
- [20] “Broadcom BCM56850 Series.” <https://www.broadcom.com/products/Switching/Data-Center/BCM56850-Series>.