

System Power Minimization to Access Non-Contiguous Spectrum in Cognitive Radio Networks

Muhammad Nazmul Islam, Narayan B. Mandayam*, Sastry Kompella[†] and
Ivan Seskar*

Qualcomm, Email: mislam@qti.qualcomm.com, * WINLAB, Rutgers
University, Email: {narayan,seskar}@winlab.rutgers.edu, [†] Naval Research
Laboratory, Email: sk@ieee.org

Abstract

Wireless transmission using non-contiguous chunks of spectrum is becoming increasingly important due to a variety of scenarios such as: secondary users avoiding incumbent users in TV white space; anticipated spectrum sharing between commercial and military systems; and spectrum sharing among uncoordinated interferers in unlicensed bands. Multi-Channel Multi-Radio (MC-MR) platforms and Non-Contiguous Orthogonal Frequency Division Multiple Access (NC-OFDMA) technology are the two commercially viable transmission choices to access these non-contiguous spectrum chunks. Fixed MC-MRs do not scale with increasing number of non-contiguous spectrum chunks due to their fixed set of supporting radio front ends. NC-OFDMA allows nodes to access these non-contiguous spectrum chunks and put null sub-carriers in the remaining chunks. However, nulling sub-carriers increases the sampling rate (spectrum span) which, in turn, increases the power consumption of radio front ends. Our work characterizes this trade-off from a cross-layer perspective, specifically by showing how the slope of ADC/DAC's power consumption versus sampling rate curve influences scheduling decisions in a multi-hop network. Specifically, we provide a branch and bound algorithm based mixed integer linear programming solution that performs joint power control, spectrum span selection, scheduling and routing in order to minimize the system power of multi-hop NC-OFDMA networks. We also provide a low complexity ($O(E^2M^2)$) greedy algorithm where M and E denote the number of channels and links respectively. Numerical simulations suggest that our approach reduces system power by 30% over classical transmit power minimization based cross-layer algorithms.

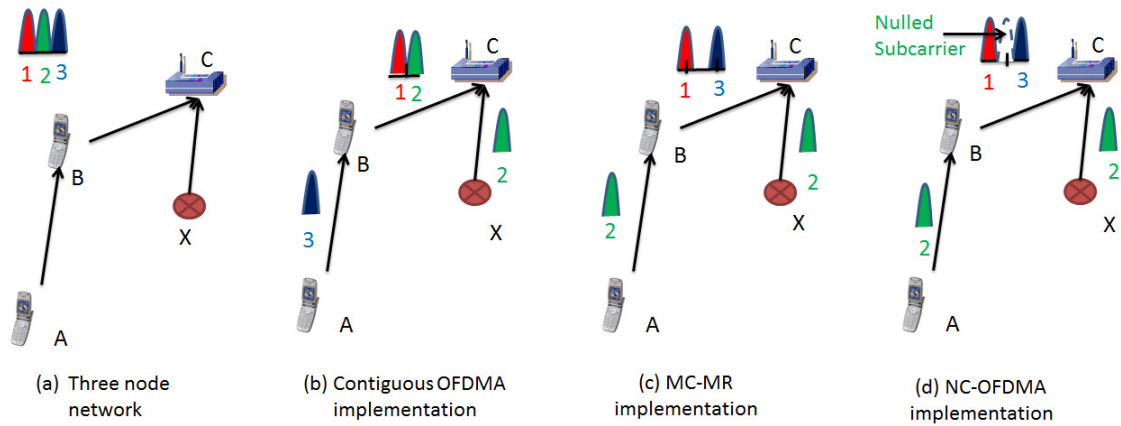

Fig. 1: Motivation of Non-contiguous Spectrum Access

Index Terms

Cognitive radio networks, software defined radio, NC-OFDMA, TV white space, circuit power.

I. INTRODUCTION

Demand for wireless services is becoming much greater than the currently available spectrum [1]. FCC has already opened up 300 MHz in TV bands [2] and plans to open up an additional 500 MHz by 2020 [3] to meet this demand. Any radio can use these channels if it abides by FCC specifications [3]. If uncoordinated networks (e.g. different broadband wireless service providers) use these channels, they will adjust spectrum usage according to their individual traffic demands. Available spectrum will become partitioned into a set of non-contiguous segments. For some bands, like white space [2], available spectrum itself is non-contiguous.

Multi-Channel Multi-Radio (MC-MR) technology allows nodes to simultaneously access multiple fragmented spectrum chunks [4], [5]. However, the number of non-contiguous spectrum chunks that fixed MC-MR can access is limited by the number of available radio front ends; which is often constrained due to the size and power limitations of the transmission device [6]. Software defined radio based Non-Contiguous Orthogonal Frequency Division Multiple Access (NC-OFDMA) technology allows nodes to transmit in these non-contiguous spectrum chunks with a single radio front end. Nodes can null interference-limited subcarriers and select better channels in NC-OFDMA enabled networks. Hence, NC-OFDMA has

grabbed a lot of attention in resource allocation [7]–[9], cooperative forwarding [10], [11] and experimental research [12], [13]. However, nulling unwanted channels increases the spectrum span and the sampling rate of nodes.

Fig. 1 illustrates the benefits and inherent challenges of NC-OFDMA using the example of a two-hop network. Fig. 1(a) shows a two-hop network where node A transmits to node C via node B; node B relays node A's data and also transmits its own data to node C. Channel 1, 2 and 3 are available channels. Node X, an external and uncontrollable interferer, transmits in channel 2. If we want to minimize the maximum rate between node A and B and allocate channels accordingly, node B will require two channels and node A will require one channel. There are three possible techniques/configurations to allocate the three available channels as shown in Figures 1(b) through 1(d). Fig. 1(b) shows contiguous OFDMA that suffers from interference in link BC at channel 2. Fig. 1(c) shows MC-MR that requires two radio front ends to capture channel 1 and 3 in link BC. Fig. 1(d) shows NC-OFDMA that uses only one radio front end, transmits at channel 1 and 3 and nulls channel 2. However, due to the nulling of channel 2, NC-OFDMA spans three channels, instead of two.

It is well known that the circuit power consumption of ADC and DAC increase linearly and exponentially with sampling rate and the number of quantization bits respectively [14], [15]. As software defined radios continue to improve their higher quantization resolution, the ADC and DAC that are used in the radio circuits will dominate the amount of power consumption. A comparison between Table I and Table II shows that the power consumption of some commercial ADCs is more than 10 dB higher than the maximum allowed transmission power for portable devices in the 802.22 standard. On the one side, NC-OFDMA reduces transmission power by selecting channels with better link gains, while on the other side, this increased spectrum span increases circuit power consumption of the transceiver. In this paper, we investigate this trade-off between transmission power reduction and circuit power increase in the context of cross-layer optimization of NC-OFDMA based wireless networks.

Specifically, we ask the following question in this work: *How can single front end radio based nodes of a multi-hop network access non-contiguous spectrum chunks?* We investigate this question from a system power perspective and find that *scheduling a small subset of channels may outperform traditional transmit power minimization based approaches – which allocate power across all ‘good’ channels – since it consumes less circuit power.* Our algorithm selects scheduling variables based on the slope of ADC and DAC power consumption versus sampling rate curves. We show two special sub-cases of this finding.

Device Name	Device Type	Max. Sampling Rate (MS/s)	Power Dissipation (mW)
AD 9777 [16]	DAC	150	1056
ADS62P4 [17]	ADC	125	908
ADC 9467B [18]	ADC	250	1333

TABLE I: Maximum Sampling Rates and Power Dissipation of Different ADC/DAC

Device Type	Allowed Power (mW)	Operating Frequency (MHz)
Fixed	4000	54 - 698
Portable	100	512-698

TABLE II: Maximum Allowed Power and Operating Frequencies in IEEE 802.22 [19]

We find that if the curves are almost flat, our algorithm converges to the transmission power minimization based scheduling algorithms. If the curves are very steep, our algorithm selects the channel with the highest link gain. For commercial ADC & DAC's whose slopes lie between these two extreme cases, our algorithm selects channels to minimize the summation of transmit and circuit powers of the network.

In general, we provide a branch and bound algorithm based mixed integer linear programming solution that performs joint power control, spectrum span selection, scheduling & routing and minimizes system power of multi-hop NC-OFDMA networks. We also provide a greedy algorithm that runs in $O(E^2M^2)$ time where E and M denote the number of links and channels respectively. *To the best of our knowledge, ours is the first work that shows how the slope of ADC/DAC's power consumption curve influences the scheduling decisions of a multi-hop network.* Numerical simulations suggest that our approach reduces system power by 30% over classical transmission power minimization based cross-layer algorithms.

A. Related Work

The authors of [4], [5] characterized the capacity region of an MC-MR based multi-hop network. The authors of [7], [8] focused on software defined radio based multi-hop networks and performed cross layer optimization using a protocol and signal-to-interference-plus-noise-ratio model respectively. None of these works considered circuit power and addressed how

non-contiguous spectrum access influences cross-layer decisions.

Consideration of system power has been gaining attention in energy efficient wireless communications literature [20]. Cui et. al. focused on system energy constrained modulation optimization in [14]. Sahai et. al. investigated system power consumption – especially decoder power consumption – in [21]. Isheden and Fettweis assumed circuit power to be a linear function of the data rate [22]. All these works focused on single transceiver pair. Our approach differs from these works in the following way: in NC-OFDMA technology, ADC and DAC consume power not only for used channels (i.e. transmitted data) but also for nulled channels. Our work considers the power consumption related to spectrum span and investigates the performance of NC-OFDMA based multi-hop networks.

The impact of hardware constraints on the performance of NC-OFDMA networks was previously raised in [23], [24]. The authors of [23] performed cross-layer resource allocation when each node's maximum spectrum span is limited by its ADC/DAC. The authors of [24] investigated how the size of the guardband, required to reduce cross-band interference, affects the performance of NC-OFDMA based distributed transceiver pairs. Our work uses system power to investigate the performance of NC-OFDMA based multi-hop networks.

Periodic non-uniform sampling (PNS) can recover a sparsely located non-contiguous signal with sub-Nyquist sampling rate [25] and potentially reduce the power consumption of the ADC circuits. However, PNS requires Nyquist rate circuitry at track-and-hold stages. PNS also needs compensation for imperfect production of the time delay elements. As a result, PNS is not widely used by industry to access non-contiguous spectrum [26]. Our work focuses on the system power minimization of an NC-OFDMA network that uses commercial ADCs and DACs with Nyquist sampling rate to access non-contiguous spectrum.

Time and frequency mismatch affect an NC-OFDMA network more severely due to its use of a large number of nulled sub-carriers. Several researchers have implemented different techniques to reduce interference between unsynchronized NC-OFDMA nodes. The authors of [13] have used adaptive multi-bank stop-band filters to reduce interference of unwanted channels. The authors of [12] have used wider guard bands to reduce leakage power into neighboring channels. We do not focus on synchronization techniques and testbed implementation of NC-OFDMA nodes in our work. Interested readers are suggested to go through [12], [13], [27], [28] to understand the implementation and synchronization details of NC-OFDMA.

The remainder of the paper is organized as follows: Section II presents system power and multi-hop network model. Section III provides a branch and bound based solution of the

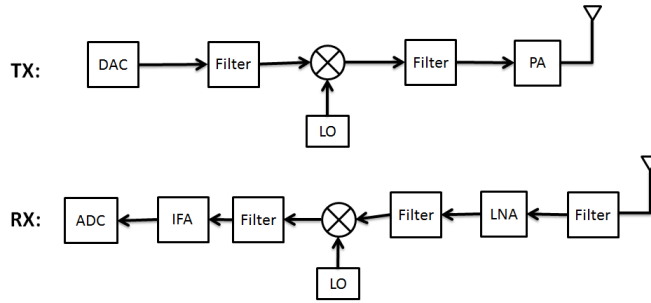

Fig. 2: Radio front end circuit blocks (reproduced from [14])

optimization problem. We present theoretical insights of our algorithm in Section IV and a low complexity algorithm in Section IV-B. After showing numerical results in section V, we conclude in section VI.

II. SYSTEM MODEL

A. System Power Model

We assume that baseband signal processing techniques like multi-user detection and iterative decoding are not employed in the system. In this context, power consumption in the baseband is negligible compared with that in the radio frequency (RF) circuitry [29]. Each radio node has two front ends: one for transmission and the other for reception. Nodes are half-duplex, i.e., they can simultaneously transmit and receive using these two front ends but not in the same channel.

Fig. 2 shows signal level blocks in the transmitter and receiver. At the transmitter, the baseband digital signal goes through DAC, filters, mixer (where it gets multiplied by the local oscillator (LO)) and programmable amplifier (PA) before reaching transmitter antenna. The received signal at the antenna goes through low noise amplifiers (LNA), filters, mixer, intermediate frequency amplifier (IFA) and ADC to reach the baseband circuit [14].

Typically, transceiver circuits work on a multi-mode basis. When there is a signal to transmit, all RF circuits work in active mode; when there is no signal to transmit, all RF circuits remain in sleep mode; circuits switch from sleep to active mode through transient mode [14]. Here, we focus on system power minimization of all RF circuits in the active mode. Let p_t , p_r and p denote active mode power consumption of transmitter and receiver,

and transmitter's emitted power at radio frequency respectively. Now,

$$p_t = \frac{PAPR}{\eta}p + p_{tc}, \quad p_r = p_{rc} \quad (1)$$

where $PAPR$ and η denote the peak-to-average-power-ratio (PAPR) and drain efficiency of the programmable amplifier. $\frac{PAPR}{\eta}p$ denote the total power consumption of programmable amplifier [14]. Also, p_{tc} and p_{rc} are the circuit power consumption of transmitter (excluding programmable amplifier's power consumption) and receiver, respectively.

The power consumption at almost all blocks of the radio front end, except ADC and DAC, does not depend on sampling rate [14], [30]. The power consumption of ADC and DAC are affine functions of the sampling rate [14], [15]. Denoting $k_{pa} = \frac{PAPR}{\eta}$, system power consumption in the transmitter and receiver front end become:

$$p_t = \alpha_1 + \alpha_2 f_{st} + k_{pa}p \quad (2)$$

$$p_r = \beta_1 + \beta_2 f_{sr} \quad (3)$$

In the above, f_{st} and f_{sr} are the sampling rates of the transmitter and receiver path. α_1 , α_2 , β_1 and β_2 are constants that depend on the power consumption of different blocks. Appendix A describes the power consumption of each block in details. Table III shows the list of notations that we have used throughout the paper.

B. Multi-hop cross-layer model

We consider a multi-hop network with a set of \mathcal{N} cognitive radio nodes. Let \mathcal{M} denote the set of all available channels. Bandwidth of each channel is W .

1) *Power Control and Scheduling Constraints:* The number of available channels may vary in different (spatial) parts of the network due to interference and other spectrum constraints such as primary users and systems. Hence, we focus on frequency scheduling. Denote the binary scheduling decision x_{ij}^m as follows:

$$x_{ij}^m = \begin{cases} 1, & \text{if node } i \text{ transmits to node } j \text{ using channel } m. \\ 0, & \text{otherwise.} \end{cases} \quad (4)$$

Due to self-interference, node i can use channel m only for receiving from node k or transmitting to node j . In other words:

$$\sum_{j \in \mathcal{N}, j \neq i} x_{ij}^m + \sum_{k \in \mathcal{N}, k \neq i} x_{ki}^m \leq 1 \quad \forall i \in \mathcal{N}, \forall m \in \mathcal{M}_i \quad (5)$$

Notation	Description
\mathcal{N}	Set of nodes
N	Total number of nodes
\mathcal{E}	Set of edges
E	Total number of edges
\mathcal{L}	Set of sessions
L	Total number of sessions
$(s(l), d(l))$	Source and destination of session l
$r(l)$	Rate requirements of session l
W	Bandwidth of each channel
N_0	Noise spectral density
$f_{ij}^m(l)$	Flow on link ij in channel m for session l
c_{ij}^m	Capacity on link ij in channel m
s_{ij}^m	Signal-to-noise ratio on link ij in channel m
\mathcal{M}	Set of all available channels across all nodes
\mathcal{M}_i	Set of available channels in node i
P_I	Interference threshold
\mathcal{M}_{ij}	Set of available channels between node i and j
M	Total number of available channels
g_{ij}^m	Link gain of ij in channel m
$p_{ij,m}$	Allocated power between i and j in channel m
x_{ij}^m	If link ij uses channel m
$x_i^{t,m}$	If node i uses channel m for transmission
$x_i^{r,m}$	If node i uses channel m for reception
$q_{t,i}$	Spectrum span of the transmitter path of node i
$q_{r,i}$	Spectrum span of the receiver path of node i
$f_{st,i}$	Sampling rate of node i 's transmitter path
$f_{sr,i}$	Sampling rate of node i 's receiver path
$f_{s,max}$	Maximum allowed sampling rate of the nodes
$P_{s,max}$	Maximum allowed system power consumption
A	An arbitrary large number

TABLE III: List of Notations

We use protocol interference model. Assume that node i transmits to node j in channel m , i.e., $x_{ij}^m = 1$. Let p_{ij}^m and g_{ij}^m denote the transmission power and channel gain in channel m of link ij . Let P_I denote the interference threshold. P_I should be chosen in such a way so that it is negligible compared to the noise power N_0W where N_0 is the noise spectral density. Another node k can transmit to node h in channel m if p_{kh}^m causes negligible interference in

node j . Hence,

$$p_{kh}^m \leq \frac{P_I}{g_{kj}^m} x_{ij}^m \quad \forall (k, h) \in \mathcal{N}, k \neq i, h \neq j \quad (6)$$

Also, a node can allocate power in a link only if it is scheduled, i.e.

$$p_{ij}^m \leq A x_{ij}^m \quad \forall (i, j \in \mathcal{N}), m \in \mathcal{M} \quad (7)$$

Here, A is a big number that couples power control and scheduling variables.

2) *Routing and Link Capacity Constraints*: Let \mathcal{L} be the set of active sessions and $|\mathcal{L}| = L$. Let $s(l)$, $d(l)$ and $r(l)$ denote the source node, destination node, and minimum rate requirements of session l . Let $f_{ij}^m(l)$ denote the flow from node i to node j in channel m for session l . If i is the source (destination) node of session l , the total outgoing (incoming) flow from (to) node i should exceed the minimum rate requirements of session l , i.e.,

$$\sum_{j \in \mathcal{N}} \sum_{m \in \mathcal{M}_{ij}} f_{ij}^m(l) \geq r(l) \quad (l \in \mathcal{L}, i = s(l)) \quad (8)$$

$$\sum_{k \in \mathcal{N}} \sum_{m \in \mathcal{M}_{ki}} f_{ki}^m(l) \geq r(l) \quad (l \in \mathcal{L}, i = d(l)) \quad (9)$$

The incoming flow of session l should match the outgoing flow in an intermediate node i :

$$\sum_{j \in \mathcal{N}, j \neq s(l)} \sum_{m \in \mathcal{M}_{ij}} f_{ij}^m(l) = \sum_{k \in \mathcal{N}, k \neq d(l)} \sum_{m \in \mathcal{M}_{ki}} f_{ki}^m(l) \quad \forall (l \in \mathcal{L}, i \in \mathcal{N}, i \neq s(l), d(l)) \quad (10)$$

Additionally, the aggregated flows of all sessions in a particular link should not exceed the capacity of the link. Therefore,

$$\sum_{l \in \mathcal{L}} f_{ij}^m(l) \leq c_{ij}^m \quad (i, j \in \mathcal{N}, i \neq j, \forall m \in \mathcal{M}_{ij}, \mathcal{M}_{ij} \neq \emptyset) \quad (11)$$

where

$$c_{ij}^m \leq W \log(1 + s_{ij}^m) \quad (i, j \in \mathcal{N}, i \neq j) \quad (12)$$

$$s_{ij}^m = \frac{g_{ij}^m p_{ij}^m}{N_0 W}, \quad (i, j \in \mathcal{N}, i \neq j). \quad (13)$$

In the above, c_{ij}^m and s_{ij}^m denote the capacity and signal-to-noise-ratio in link ij of channel m . The denominator of s_{ij}^m only contains $N_0 W$ because (6) ensures that the interference from other nodes is negligible compared to the noise power.

The constraints described above resemble previous works that focus on *transmission power* based cross-layer optimization (i.e., power control, scheduling and routing). The novelty of the work here is in relating the hardware constraints imposed by the radio front-end to the above cross-layer optimization as we describe next.

C. System Power Constraints

Let $p_{t,i}$ and $p_{r,i}$ denote the system power consumption in the transmitter and receiver path of node i . The total system power consumption, P_{tot} , is:

$$P_{tot} = \sum_{i \in \mathcal{N}} (p_{t,i} + p_{r,i}) \quad (14)$$

Equation (2) and (3) show a radio node also contains a fixed amount of power (independent of sampling rate) if it transmits or receives in a channel. Denoting α_{1_i} and β_{1_i} as this fixed power consumption of node i 's transmit and receive path respectively, we find,

$$\alpha_{1_i} \geq \alpha_1 x_{ij}^m \quad \forall m \in \mathcal{M}_{ij}, j \in \mathcal{N}, i \in \mathcal{N} \quad (15)$$

$$\beta_{1_i} \geq \beta_1 x_{ki}^m \quad \forall m \in \mathcal{M}_{ij}, k \in \mathcal{N} i \in \mathcal{N}. \quad (16)$$

Using (2), (3), (14), (15) and (16),

$$\sum_{i \in \mathcal{N}} (\alpha_{1_i} + \alpha_2 f_{st,i} + \sum_{j \in \mathcal{N}} \sum_{m \in \mathcal{M}_{ij}} k_{pa} p_{ij}^m + \beta_{1_i} + \beta_2 f_{sr,i}) = P_{tot} \quad (17)$$

where $f_{st,i}$ and $f_{sr,i}$ denote the sampling rates in the transmitter and receiver of node i .

The constraints introduced so far involve channel scheduling decisions and sampling rate of different nodes. We now show how channel scheduling decisions influence the sampling rate of the nodes, which in turn influences the total system power.

D. Relation between Channel Scheduling and System Power

The sampling rate of a transceiver depends on its spectrum span, which in turn is determined by the choice of channels selected for its intended transmission.

Let $x_i^{t,m}$ and $x_i^{r,m}$ denote the following:

$$x_i^{t,m} = \begin{cases} 1, & \text{if } i \text{ transmits to any node } j \in \mathcal{N} \text{ in channel } m. \\ 0, & \text{otherwise.} \end{cases}$$

$$x_i^{r,m} = \begin{cases} 1, & \text{if } i \text{ receives from any node } j \in \mathcal{N} \text{ in channel } m. \\ 0, & \text{otherwise.} \end{cases}$$

In other words,

$$\begin{aligned} x_i^{t,m} &\geq x_{ij}^m \quad \forall j \in \mathcal{N}, \\ x_i^{r,m} &\geq x_{ki}^m \quad \forall k \in \mathcal{N}, \end{aligned} \quad (18)$$

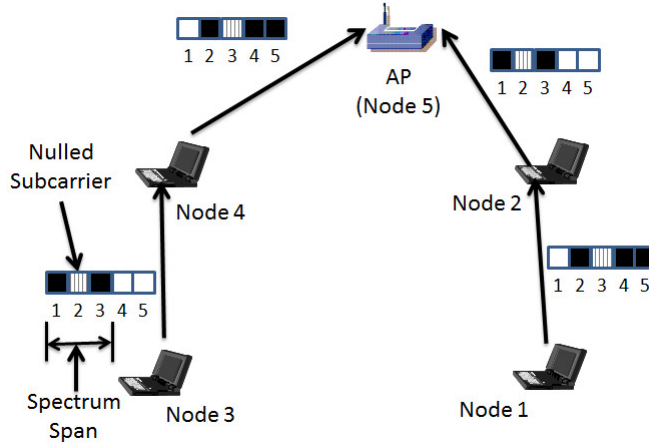

Fig. 3: Spectrum span, occupied and nulled subcarrier in an NC-OFDMA based multi-hop network. Black solid, lined ash and white boxes denote occupied, nulled and un-spanned subcarriers respectively. Spectrum span is the summation of occupied and nulled subcarriers.

Using this notation, analog power equations of (15) and (16) are redefined as,

$$\alpha_{1_i} \geq \alpha_1 x_i^{t,m}, \quad \beta_{1_i} \geq \beta_1 x_i^{r,m}, \quad \forall m \in \mathcal{M}_i, \quad \forall i \in \mathcal{N} \quad (19)$$

We define spectrum span as the gap between the furthest edges of the used channels. Node i 's uppermost used channel index in the transmitter path is:

$$\max_{m \in \mathcal{M}_i} m \cdot x_i^{t,m} \quad (20)$$

Node i 's lowermost used channel index in the transmitter path is:

$$\min_{m \in \mathcal{M}_i} (m \cdot x_i^{t,m} + |M| \cdot (1 - x_i^{t,m})). \quad (21)$$

The second term of (21) ensures that we do not consider the index i 's for which $x_i^{t,m} = 0$. Let $q_{t,i}$ and $q_{r,i}$ denote the spectrum spans of the transmitter and receiver path of node i . Now,

$$q_{t,i} = W \cdot \max\left(\left(\max_{m \in \mathcal{M}_i} (m \cdot x_i^{t,m}) - \min_{m \in \mathcal{M}_i} (m \cdot x_i^{t,m} + |M| \cdot (1 - x_i^{t,m}))\right) + 1, 0\right) \quad (22)$$

$$q_{r,i} = W \cdot \max\left(\left(\max_{m \in \mathcal{M}_i} (m \cdot x_i^{r,m}) - \min_{m \in \mathcal{M}_i} (m \cdot x_i^{r,m} + |M| \cdot (1 - x_i^{r,m}))\right) + 1, 0\right) \quad (23)$$

Fig. 3 illustrates the concept of spectrum span in a five node multi-hop network. We now verify (20) - (23) by focusing on the spectrum span of node 3 of Fig. 3. There are 5 available

channels. Node 3 transmits in channel 1 and 3, and nulls channel 2. Node 3 does not receive in any channel from other nodes. Hence,

$$\begin{aligned}\mathcal{M} &= \{1, 2, 3, 4, 5\}, x_3^{r,m} = 0 \forall m \in \mathcal{M}, \\ x_3^{t,m} &= 1 \forall m \in \{1, 3\}, x_3^{t,m} = 0 \forall m \in \{2, 4, 5\}\end{aligned}$$

Using the values of \mathcal{M} , $x_3^{r,m}$ and $x_3^{t,m}$ in (22) and (23), $q_{r,3} = 0$ and $q_{t,3} = 3W$. Fig. 3 shows that node 3 does not receive from any node and spans three channels while transmitting to node 4.

Now, using (19), (22) and (23), along with the fact that sampling rate of a transceiver should be at least twice its spectrum span, we convert (17) to the following:

$$\sum_{i \in \mathcal{N}} (\alpha_{1_i} + 2\alpha_2 q_{t,i} + \sum_{j \in \mathcal{N}} \sum_{m \in \mathcal{M}_{ij}} p_{ij}^m + \beta_{1_i} + 2\beta_2 q_{r,i}) = P_{tot} \quad (24)$$

Equation (19), (22)- (24) relate total system power to the scheduling variables.

In this work, our objective is to minimize the total system power subject to rate requirements. Using the above equations, we formulate our optimization problem and show it in (25).

$$\min P_{tot} \quad (25a)$$

$$\sum_{j \in \mathcal{N}} \sum_{m \in \mathcal{M}_{ij}} f_{ij}^m(l) \geq r(l) \quad (l \in \mathcal{L}, i = s(l)), \quad \sum_{k \in \mathcal{N}} \sum_{m \in \mathcal{M}_{ki}} f_{ki}^m(l) \geq r(l) \quad (l \in \mathcal{L}, i = d(l)) \quad (25b)$$

$$\sum_{j \neq s(l)} \sum_{m \in \mathcal{M}_{ij}} f_{ij}^m(l) = \sum_{k \neq d(l)} \sum_{m \in \mathcal{M}_{ki}} f_{ki}^m(l) \quad (l \in \mathcal{L}, i \in \mathcal{N}, i \neq s(l), d(l)) \quad (25c)$$

$$\sum_{l \in \mathcal{L}} f_{ij}^m(l) \leq c_{ij}^m \quad (i, j \in \mathcal{N}, i \neq j, \mathcal{M}_{ij} \neq \emptyset) \quad (25d)$$

$$c_{ij}^m \leq W \log(1 + s_{ij}^m) \quad (i, j \in \mathcal{N}, i \neq j), \quad s_{ij}^m = \frac{g_{ij}^m P_{ij}^m}{N_0 W}, \quad (i, j \in \mathcal{N}, i \neq j) \quad (25e)$$

$$p_{kh}^m \leq \frac{P_I}{g_{kj}} x_{ij}^m \quad \forall k \in \mathcal{N}, h \in \mathcal{N}, k \neq h, \quad p_{ij}^m \leq A x_{ij}^m \quad \forall (i, j \in \mathcal{N}), m \in \mathcal{M} \quad (25f)$$

$$q_{t,i} \geq W \cdot \left(\max_{m \in \mathcal{M}_i} (m \cdot x_i^{t,m}) - \min_{m \in \mathcal{M}_i} (m \cdot x_i^{t,m} + |M| \cdot (1 - x_i^{t,m})) + 1 \right) \quad (25g)$$

$$q_{r,i} \geq W \cdot \left(\max_{m \in \mathcal{M}_i} (m \cdot x_i^{r,m}) - \min_{m \in \mathcal{M}_i} (m \cdot x_i^{r,m} + |M| \cdot (1 - x_i^{r,m})) + 1 \right) \quad (25h)$$

$$\alpha_{1_i} \geq \alpha_1 x_i^{t,m}, \quad \beta_{1_i} \geq \beta_1 x_i^{r,m} \quad \forall m \in \mathcal{M}_i \forall i \in \mathcal{N} \quad (25i)$$

$$\sum_{j \in \mathcal{N}, j \neq i} x_{ij}^m + \sum_{k \in \mathcal{N}, k \neq i} x_{ki}^m \leq 1 \quad \forall i \in \mathcal{N}, \forall m \in \mathcal{M}_i \quad (25j)$$

$$\sum_{i \in \mathcal{N}} (\alpha_{1_i} + 2\alpha_2 q_{t,i} + \sum_{j \in \mathcal{N}} \sum_{m \in \mathcal{M}_{ij}} p_{ij}^m + \beta_{1_i} + 2\beta_2 q_{r,i}) \leq P_{tot} \quad (25k)$$

$$x_{ij}^m \in \{0, 1\}, s_{ij}^m \geq 0 \quad (i, j \in \mathcal{N}, i \neq j, m \in \mathcal{M}_{ij}), q_{t,i} \geq 0, q_{r,i} \geq 0 \quad \forall i \in \mathcal{N} \quad (25l)$$

$$P_{tot}, f_{ij}^m(l) \geq 0 \quad (l \in \mathcal{L}, m \in \mathcal{M}_{ij}, i, j \in \mathcal{N}, i \neq j, i \neq d(l), j \neq s(l), \mathcal{M}_{ij} \neq \emptyset) \quad (25m)$$

Next two sections provide solution methodologies of (25).

III. BRANCH-AND-BOUND BASED SOLUTION OVERVIEW

A. Linearization of the Optimization Problem

The optimization problem of (25) is a mixed integer non-linear program (MINLP). The non-linearity of (25) comes from the logarithm function of (25e) and max-min functions of (25g) and (25h).

The logarithmic function of the capacity term in (25e) can be linearized by reformulation linearization technique (RLT) [31]. RLT uses a number of tangential supports at different points of the logarithmic curve and generates a convex hull linear relaxation of the logarithmic function. We ask interested readers to go through [31] for the details of RLT.

The max-min equations of (22) and (23) can be re-written in following linear forms:

$$q_{t,i} + W(m_2 \cdot x_i^{t,m_2} + |M| \cdot (1 - x_i^{t,m_2})) \geq W(m_1 \cdot x_i^{t,m_1} + 1) \quad \forall (m_1, m_2) \in \mathcal{M}_i, \forall i \in \mathcal{N} \quad (26)$$

$$q_{r,i} + W(m_2 \cdot x_i^{r,m_2} + |M| \cdot (1 - x_i^{r,m_2})) \geq W(m_1 \cdot x_i^{r,m_1} + 1) \quad \forall (m_1, m_2) \in \mathcal{M}_i, \forall i \in \mathcal{N} \quad (27)$$

$$q_{t,i} \geq 0, q_{r,i} \geq 0 \quad \forall i \in \mathcal{N} \quad (28)$$

The optimization problem of (25) with the reformulated linear equations can be directly solved in CVX [32] (with MOSEK [33]) software. This problem is a MILP. CVX uses branch-and-bound algorithm [31] to solve this problem.

B. Feasible Solution

CVX outputs flow variables $f_{ij}^m(l)$, scheduling decisions x_{ij}^m and power variables p_{ij}^m ($l \in \mathcal{L}, m \in \mathcal{M}_{ij}, i, j \in \mathcal{N}, i \neq j$). Since we relaxed flow capacity equations to get this output, the resultant flow rates may exceed the capacity of the links. We keep flow variables and scheduling decisions unperturbed and increase power variables to get feasible solutions. We use the following set of equations for flows and powers:

$$\begin{aligned} \sum_{i \in \mathcal{L}} f_{ij}^m(l) &= W \log\left(1 + \frac{p_{ij}^m g_{ij}^m}{N_0 W}\right) \\ p_{ij}^m &= \frac{N_0 W}{g_{ij}^m} \left[\exp\left\{ \frac{\sum_{i \in \mathcal{L}} f_{ij}^m(l)}{W} \right\} - 1 \right] \quad \forall m \in \mathcal{M}_{ij}, i, j \in \mathcal{N}, i \neq j. \end{aligned} \quad (29)$$

These power variables along with flow and scheduling decisions of the CVX output form a feasible solution. We refer to this solution as “BnBSysPowerMin”. The resulting algorithm however suffers from exponential complexity in the worst case scenario. Next section develops low complexity algorithms to minimize system power in a multi-hop network, i.e., to solve the original optimization problem of (25).

IV. LOW COMPLEXITY ALGORITHM DESIGN

We first focus on the system power minimization of a point-to-point link. Thereafter, we use the insights obtained from this scenario to develop a low complexity algorithm to minimize system power in a multi-hop network.

A. Theoretical Insights from Point-to-Point Link Case

In a point-to-point link, the optimization problem of (25) takes the following form:

$$\min \sum_{m \in \mathcal{M}} p^m + \alpha_1 + 2\alpha_2 q + \beta + 2\beta_2 q \quad (30a)$$

$$s.t. \quad q \geq W \left(\max_{m \in \mathcal{M}} (m \cdot x^m) - \min_{m \in \mathcal{M}} (m \cdot x^m + |M|(1 - x^m)) + 1 \right), \quad x^m \in \{0, 1\}, \quad \forall m \in \mathcal{M}, \quad q \geq 0 \quad (30b)$$

$$\sum_{m \in \mathcal{M}} W \log_2 \left(1 + \frac{p^m g^m}{N_0 W} \right) \geq r, \quad p^m \geq 0, \quad \forall m \in \mathcal{M} \quad (30c)$$

$$p^m \leq A x^m \quad \forall m \in \mathcal{M} \quad (30d)$$

In above equations, p^m and g^m denote the allotted power and link gain in channel m , respectively. Rate requirement and spectrum span are denoted by r and q , respectively. In the objective function, $\sum_{m \in \mathcal{M}} p^m$ denotes transmit power and $\alpha_1 + 2\alpha_2 q + \beta + 2\beta_2 q$ denotes circuit power consumption.

The optimization problem of (30) is the combination of two separate optimization problems. The objective is to minimize the summation of transmit and circuit power. Eq. 30b denotes the constraints associated with circuit power minimization problem and it only involves spectrum span and scheduling variables. Eq. 30c denotes the constraints associated with transmit power minimization problem and it only involves power variables. Eq. 30d relates the power and scheduling variables and couples these two optimization problems.

The optimization problem of (30) has two sub cases. These sub-cases depend on the values of α_2 and β_2 , i.e., the slope of ADC & DAC’s power consumption versus sampling rate curves

1) *Case I: Transmit Power Minimization:* When α_2 and β_2 are very small, i.e., ADC and DAC's power consumption versus sampling rate curves are very flat, the impact of spectrum span on system power becomes negligible. Scheduling decisions do not influence system power that much and we can concentrate on minimizing transmit power. Then the optimization problem gets reduced to:

$$\min \sum_{m \in \mathcal{M}} p^m \quad (31a)$$

$$\sum_{m \in \mathcal{M}} W \log_2 \left(1 + \frac{p^m g^m}{N_0 W} \right) \geq r, p^m \leq A x^m, p^m \geq 0, x^m \in \{0, 1\} \quad \forall m \in \mathcal{M} \quad (31b)$$

Since x^m 's are not present in the objective function, we can just solve the problem with p^m variables and then enforce $x^m = 1$ for every positive p^m .

The optimization problem of (31) is similar to the classical waterfilling [34] problem, which maximizes rate subject to a total power constraint. In the remainder of the paper, we refer to the above problem 'TxPowerMin'. The solution to this problem selects the "good" channels in the network and spreads power across the whole spectrum [34].

2) *Case II: Circuit Power Minimization:* When α_2 and β_2 are very large, i.e., ADC and DAC's power consumption are very steep, circuit power consumption dominates system power. Transmit power variables do not influence circuit power that much and we can just concentrate on minimizing circuit power. The optimization problem reduces to,

$$\min \alpha_1 + 2\alpha_2 q + \beta + 2\beta_2 q \quad (32a)$$

$$s.t. \quad q \geq W \left(\max_{m \in \mathcal{M}} (m \cdot x^m) - \min_{m \in \mathcal{M}} (m \cdot x^m + |M|(1 - x^m)) + 1 \right), x^m \in \{0, 1\}, \forall m \in \mathcal{M}, q \geq 0 \quad (32b)$$

$$\sum_{m \in \mathcal{M}} W \log_2 \left(1 + \frac{p^m g^m}{N_0 W} \right) \geq r, p^m \geq 0, \forall m \in \mathcal{M}, p^m \leq A x^m \quad \forall m \in \mathcal{M} \quad (32c)$$

The objective of the optimization problem of (32) increases with spectrum span q . Minimum circuit power occurs if we schedule only one channel and allocate enough power in that channel so that it can meet rate requirement. Scheduling any single channel leads to same circuit power in the above optimization problem. Since the original system power minimization problem contains both transmit and circuit powers, it is prudent to select the

channel with the best link gain. This greedy selection requires less transmit power to meet rate requirement.

3) *Trade-off between transmit and circuit power minimization:* If ADC and DAC's power consumption versus sampling rate curves are very flat, our algorithm selects all good channels in the network. If ADC and DAC's power consumption vs. sampling rate curves are very steep, our algorithm selects the channel with the best link gain. In a practical setting with commercial ADCs and DAC, our algorithm trades off between transmit and circuit power.

B. Polynomial Time Algorithm for a Multihop Networks

The analysis from the point-to-point link case provides us insights to develop a low complexity greedy algorithm to solve the optimization problem of (25). The algorithm minimizes the circuit power by using only one channel at the first step and then tries to minimize the system power, i.e., the combination of transmit and circuit power, by greedily selecting more and more channels in the subsequent steps. Our greedy algorithm can be explained simply as follows:

- Find the initial route between each sender and receiver using the shortest path algorithm [35].
- Assign the best channel to each link unless the current assignment interferes with previously assigned channels.
- For each active link, check if any other channel assignment reduces system power.
- Once channels are scheduled, determine power allocation and routing through a convex optimization program.

Our greedy system power minimization algorithm consists of the central program of Algorithm 1 and the sub-routines of Algorithm 2 and Algorithm 3. Next three sub-sections describe the central program and the sub-routines. We analyze the complexity of our algorithm in Sec. IV-B4.

1) *Central Program:* Algorithm 1 shows the pseudocode of our greedy polynomial time algorithm. Operation 1 finds large scale gains of all links by averaging small scale fading in time or frequency domain. Operation 2 assigns weight to each link. Operation 3 finds the shortest path between each sender and forwarder based on the assigned weights of operation 2. Operation 5 finds the active links and operation 7 calculates the flow requirement among these links. Operation 8 initiates total power (P_{tot}), power allocation (p_{ij}^m) and scheduling (x_{ij}^m) variables to zero for the greedy channel scheduling algorithm. We initiate an outer loop

Algorithm 1 Polynomial Time Algorithm to Minimize System Power in a Multi-hop Network

Input : $\mathcal{M}, s(l), d(l), r(l) \forall l \in \mathcal{L}, W, N_0, g_m \forall m \in \mathcal{M}$

Output: $x_m, p_m \forall m \in \mathcal{M}, P_{tot}, f_{ij}^m(l) \forall m \in \mathcal{M}, \forall l \in \mathcal{L}, \forall (i, j) \in \mathcal{E}$

- 1: Denote g_{ij} as the average gain (e.g. path loss plus shadowing) of link ij .
 - 2: Assign weight w_{ij} to each link, $w_{ij} = \frac{1}{g_{ij}}$.
 - 3: Find shortest path between between source ($s(l)$) and destination ($d(l)$) of every session $l \in \mathcal{L}$ based on the link weight w .
 - 4: $b_{ij}(l) = 1$ if link ij falls in the routing path of any session $l \in \mathcal{L}$.
 - 5: A link is active if it falls in the routing path of any session, i.e., $x_{ij} = 1$ if $\exists l \in \mathcal{L}$ s.t. $b_{ij}(l) = 1$.
 - 6: Define \mathcal{A} to be set of active links.
 - 7: Flow in each link, $f_{ij} = \sum_{l \in \mathcal{L}} b_{ij}(l)r(l)$.
 - 8: $P_{tot} = \infty, x_{ij}^m = p_{ij}^m = 0 \forall (i, j) \in \mathcal{E}, \forall m \in \mathcal{M}, x_i^{t,m} = x_i^{r,m} = 0, \alpha_{1_i} = \beta_{1_i} = 0, \forall i \in \mathcal{N}, \forall m \in \mathcal{M}$
 - 9: **while** True **do**
 - 10: $flag = 0$;
 - 11: **for** $(a, b) \in \mathcal{A}$ **do**
 - 12: $(flag, x_{ij}^m, p_{ij}^m \forall m \in \mathcal{M}, (i, j) \in \mathcal{E}) =$
 GreedyAlgo($\mathcal{M}, (a, b), f_{ab}, r, W, N_0, flag, P_{tot}, \alpha_{1_i}, \beta_{1_i}, x_i^{t,m}, x_i^{r,m}, x_{ij}^m, p_{ij}^m, g_{ij}^m \forall m \in \mathcal{M}, i \in \mathcal{N}, (i, j) \in \mathcal{E}$)
 - 13: **end for**
 - 14: **if** $flag = |A|$ **then**
 - 15: Break.
 - 16: **end if**
 - 17: **end while**
 - 18: Solve the optimization problem of (25) where scheduling variables ($x_{ij}^m \forall m \in \mathcal{M}, \forall (i, j) \in \mathcal{E}$) are constants, not variables. Find power allocation, scheduling and routing variables and total power, P_{tot} .
-

in operation 9. Operation 11-13 calls the subroutine of Algorithm 2 and checks if any link should be assigned a channel. The outer loop breaks if none of the active links becomes suitable to be assigned a channel. This outer loop determines the channel scheduling (x_{ij}^m) variables.

We obtain power allocation (p_{ij}^m) and routing path ($f_{ij}(l)$) variables from the optimization problem of (25) where scheduling variables (x_{ij}^m) are constants. Since we fix the integer variables of (25), the total power minimization problem becomes a convex optimization program and can be solved in polynomial time [36].

We assume one path (shortest path), i.e., no flow splitting, per session during the initial routing topology design of operation 1- 3. This allows us to easily calculate the flow requirement of each link which we later use in the greedy scheduling algorithm. We consider optimal flow splitting, based on the selected scheduling variables, in the final optimization of operation 18 of Algorithm 1.

2) *Greedy Scheduling Algorithm*: The greedy scheduling algorithm of Algorithm 2 is a sub-routine that's called from operation 12 of the central program of Algorithm 1. The sub-routine receives previously assigned scheduling and power allocation variables from the central program. The central controller also asks the sub-routine to focus on a particular link (a, b). The sub-routine iterates through all available channels and finds the best available channel for (a, b).

Operation 1 stores the global scheduling (x_{ij}^m) and power allocation (p_{ij}^m) variables in local dummy variables $x_{new,ij}^m$ and $p_{new,ij}^m$ respectively. Operation 3 of Algorithm 2 starts the iteration for all channels. Operation 4 assigns the current channel to the focus link (a, b). Operation 5 and 6 calculate the transmit span ($q_{t,i}$) and receiver span ($q_{r,i}$) for all nodes $i \in \mathcal{N}$. Operation 7 assumes equal flow allocation among the selected channels and finds the power allocation in link (a, b) to meet rate requirement. Operation 8 calls the sub-routine of Algorithm 3 and checks if current channel assignment causes interference to other links. Operation 12 calculates total system power of the current iteration. Operation 15 comes out of the loop. Operation 16 finds the minimum system power ($P_{tot,new}$) among all possible channel allocations. Operation 17-23 compare the achievable minimum system power ($P_{tot,new}$) with the stored global system power (P_{tot}) and update scheduling and power variables accordingly.

We assume equal flow per channel in each link in operation 7 and 20 of Algorithm 2. This simplifies the calculation of transmission power per channel and avoids the computation of a convex optimization program in each loop. However, we consider optimal flow and power

Algorithm 2 Greedy Scheduling Algorithm

Input : \mathcal{M} , Link (a, b) , f_{ab} , r , W , N_0 , $flag$, α_{1_i} , β_{1_i} , $x_i^{t,m}$, $x_i^{r,m}$, x_{ij}^m , p_{ij}^m , $g_{ij}^m \forall (i, j) \in \mathcal{E}$, $\forall i \in \mathcal{N}$, $\forall m \in \mathcal{M}$

Output: $flag$, x_{ij}^m , $\forall (i, j) \in \mathcal{E}$, $\forall m \in \mathcal{M}$

- 1: $x_{new,ij}^m = x_{ij}^m$, $p_{new,ij}^m = p_{ij}^m$, $\forall (i, j) \in \mathcal{E}$, $\forall m \in \mathcal{M}$
 - 2: $f_{new,ab}^m = \frac{f_{ab}}{\sum_{m \in \mathcal{M}} x_{new,ab}^m + 1} \cdot x_{new,ab}^m$, $p_{new,ab}^m = \frac{N_0 W}{g_{ab}^m} \cdot (2^{\frac{f_{new,ab}^m}{W}} - 1) x_{new,ab}^m \forall m \in \mathcal{M}$
 - 3: **for** $m \in \mathcal{M}$ **where** $x_{ab}^m \neq 1$ **do**
 - 4: $x_{new,ab}^m = 1$, $x_a^{t,m} = 1$, $x_b^{r,m} = 1$, $\alpha_{1_a} = \alpha_1$, $\beta_{1_b} = \beta_1$
 - 5: $q_{t,i} = W \cdot (\max_{m \in \mathcal{M}} (m \cdot x_i^{t,m}) - \min_{m \in \mathcal{M}} (m \cdot x_i^{t,m} + |M| \cdot (1 - x_i^{t,m})) + 1) \forall i \in \mathcal{N}$
 - 6: $q_{r,i} = W \cdot (\max_{m \in \mathcal{M}_i} (m \cdot x_i^{r,m}) - \min_{m \in \mathcal{M}_i} (m \cdot x_i^{r,m} + |M| \cdot (1 - x_i^{r,m})) + 1) \forall i \in \mathcal{N}$
 - 7: $f_{new,ab}^m = \frac{f_{ab}}{\sum_{m \in \mathcal{M}} x_{new,ab}^m} \cdot x_{new,ab}^m$, $p_{new,ab}^m = \frac{N_0 W}{g_{ab}^m} \cdot (2^{\frac{f_{new,ab}^m}{W}} - 1) x_{new,ab}^m$
 - 8: $IntFlag = IntCheck(x_{new,ab}^m, p_{new,ab}^m, \mathcal{M}, \mathcal{A}, W, N_0, x_{ij}^m, p_{ij}^m \forall (i, j) \in \mathcal{E})$
 - 9: **if** $IntCheck(\cdot) = 1$ **then**
 - 10: $P_{new,tot}^m = \infty$
 - 11: **else**
 - 12: $P_{new,tot}^m = \sum_{i \in \mathcal{N}} (\alpha_{1_i} + 2\alpha_2 q_{t,i} + \sum_{j \in \mathcal{N}} \sum_{m \in \mathcal{M}_{ij}} p_{new,ij}^m + \beta_{1_i} + 2\beta_2 q_{r,i})$
 - 13: **end if**
 - 14: $x_a^{t,m} = 0$, $x_b^{r,m} = 0$
 - 15: **end for**
 - 16: $P_{tot,new} = \min_{m \in \mathcal{M}} P_{tot,new}^m$, $ind = \arg \min_{m \in \mathcal{M}} P_{tot,new}^m$
 - 17: **if** $P_{tot,new} < P_{tot}$ **then**
 - 18: $x_{ab}^{ind} = 1$.
 - 19: $x_a^{t,ind} = 1$, $x_b^{r,ind} = 1$, $\alpha_{1_a} = \alpha_1$, $\beta_{1_b} = \beta_1$.
 - 20: $f_{ab}^m = \frac{f_{ab}}{\sum_{m \in \mathcal{M}} x_{ab}^m} \cdot x_{ab}^m$, $p_{ab}^m = \frac{N_0 W}{g_{ab}^m} \cdot (2^{\frac{f}{W}} - 1) x_{ab}^m \forall m \in \mathcal{M}$
 - 21: **else**
 - 22: $flag = flag + 1$
 - 23: **end if**
 - 24: **return**
-

allocation in our final optimization problem of operation 18 of Algorithm 1.

3) *Interference Checking Algorithm*: The sub-routine of Algorithm 3 gets called from operation 8 of the greedy scheduling algorithm of Algorithm 2. This sub-routine checks if the scheduling and power allocation of link ab in channel m , calculated in Algorithm 2, interferes with other links. Operation 3 of Algorithm 3 checks if transmitted power in link ab causes interference to any non-adjacent link that uses channel m . Operation 6 checks if link ab maintains half duplex relationships with its adjacent links. Operation 11 updates the interference flag and returns this value to the greedy scheduling sub-routine of Algorithm 2.

Algorithm 3 Primary and Secondary Interference Checking Algorithm

Input : $x_{new,ab}^m, p_{new,ab}^m, \mathcal{M}, \mathcal{A}, W, N_0, x_{ij}^m, p_{ij}^m \forall (i, j) \in \mathcal{A}$

Output: $Intflag$

```

1:  $count = 0, Intflag = 0$ 
2: for  $(i, j) \in \mathcal{A}, i \neq a, j \neq b$  do
3:   if  $((p_{new,ab}^m g_{aj}^m \geq 0.1N_0Wx_{ij}^m) || (p_{ij}^m g_{ib}^m \geq 0.1N_0Wx_{new,ab}^m))$  then
4:      $count = count + 1$ 
5:   end if
6:   if  $(x_{ia}^m + x_{ab}^m + x_{bj}^m > 0)$  then
7:      $count = count + 1$ 
8:   end if
9: end for
10: if  $count > 0$  then
11:    $Intflag = 1$ 
12: end if
13: return

```

4) *Computational Complexity*: Global system power minimization algorithm of Algorithm 1 contains three major parts: 1) Initial routing path selection (operation 1-3) of Algorithm 1, 2) channel scheduling (operation 9-17) of Algorithm 1 along with Algorithm 2 and Algorithm 3, and 3) optimal power control and routing path design (operation 18 of Algorithm 1).

Initial routing path selection involves computing link weights ($O(E)$) and shortest path ($O(E + N \log N)$) for L sessions. Therefore, the overall complexity for this part is: $O(L(E +$

$N \log N$)).

The greedy scheduling algorithm starts with a while loop. The while loop iterates through all active links ($O(E)$). Each link calls the sub-routine of Algorithm 2, iterates through M channels. Inside each channel, the code calls the sub-routine of Algorithm 3. Algorithm 3 checks if the current channel assignment interferes with other links ($O(E)$). The global while loop of Algorithm 1 can iterate at most $O(M)$ times since each iteration will either select a channel for a link or the loop will break. Therefore, the greedy scheduling algorithm runs in $O(E^2M^2)$ time.

The optimal power allocation and routing path selection problem of operation 18 of Algorithm 1 is a convex optimization program. Barrier method [36] can solve this in $O(R \log(R))$ steps where R is the number of inequality constraints. From (25), we find the complexity to be $O(EM \log(EM))$.

The greedy scheduling part dominates the overall complexity ($O(E^2M^2)$) of Algorithm 1. We term this algorithm “GreedySysPowerMin”. We compare the performance of both “GreedySysPowerMin” and “BnBSysPowerMin” with that of “TxPowerMin” in Sec. V.

The number of channel M does not denote the number of subcarriers in a multi-hop network. It represents the number of wideband channels, e.g., 6 MHz TV channels in white space and 20 MHz channels in 5.8 GHz, in the network. This ensures that our overall complexity ($O(E^2M^2)$) remains reasonable for a moderately sized network.

V. SIMULATION RESULTS

A. System Power Minimization in a Single Point-to-Point Link

We focus on an NC-OFDMA based single transceiver pair. There is only one session in the network and minimum data rate requirement is 18 Mbps. There are 20 channels available for transmission. Each channel is 3 MHz wide. The left sub-plot of Fig. 4 shows the link gains across these channels. We designed the link gains so that every other channel has better link gain than its adjacent neighbors.

The second subplot (from the left) of Fig. 4 shows the power allocation and scheduling variables of TxPowerMin approach. This approach minimizes transmit power subject to the rate constraint. Similar to the concept of “waterfilling” algorithm [34], this approach spreads power across all ten “good” channels of the network.

The third and fourth subplot (from the left) of Fig. 4 shows the scheduling and power variables of our greedy algorithm (GreedySysMin). We use two different types of ADC and

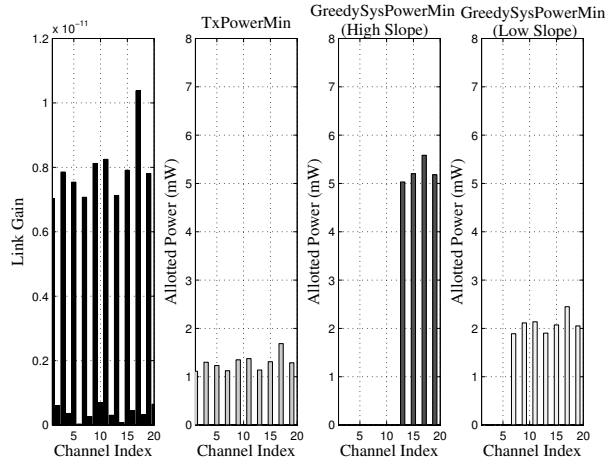

Fig. 4: Comparison of ‘TxPowerMin’ and our approach in power allocation and scheduling

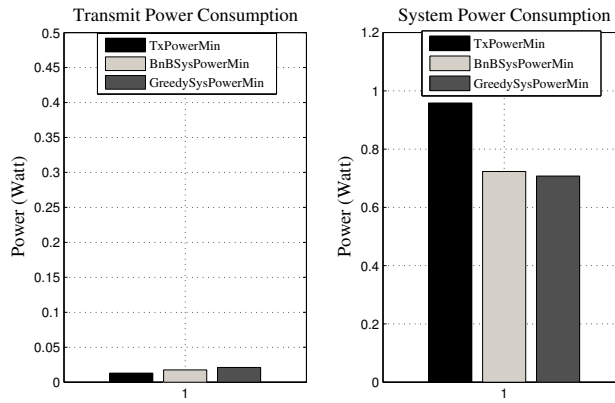

Fig. 5: Comparison of our algorithms with the ‘TxPowerMin’ approach using the high slope ADC/DAC’s of Fig. 9a and Fig. 9b.

DAC models to investigate the influence of ADC/DAC slopes on our algorithm. We use the high slope ADC and DAC models – ADC 9777 and ADS 62P4 (see Fig. 9a and Fig. 9b) – in the third subplot of Fig. 4 and the low slope ADC and DAC model – DAC 3162 and ADS 4249 (see Fig. 9a and Fig. 9b) – in the fourth subplot (the rightmost one) of Fig. 4. With high slope ADC & DAC, our algorithm focuses more on minimizing circuit power and selects only four channels. With low slope ADC & DAC, our approach finds a trade-off between transmit & circuit power and selects seven channels.

Fig. 5 compares the performance of our algorithm with that of TxPowerMin approach in high ADC/DAC slope setting. “TxPowerMin” approach minimizes transmit power by spreading data across all “good” channels of the network. Both of our algorithms consume

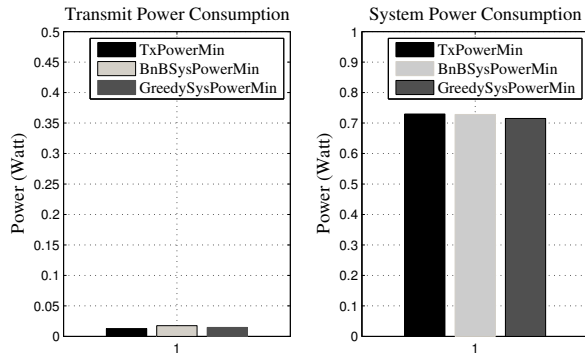

Fig. 6: Comparison of our algorithms with the ‘TxPowerMin’ approach using the low slope ADC/DAC’s of Fig. 9a and Fig. 9b.

Channel Index	2	5	6	17	23	24	47
Center Freq. (MHz)	57	79	85	491	527	533	671

TABLE IV: Available TV channels for fixed devices in Wichita, Kansas.

more transmit power than the “TxPowerMin” approach since selecting a subset of available good channels is a sub-optimal policy in terms of transmit power. Our algorithms consume less circuit power due to the reduced spectrum span. Overall, our algorithms reduce system power – summation of transmit and circuit power – consumption by almost 30%.

Note that, the lower bound of the system power consumption (obtained from the mixed integer linear programming relaxation), was 0.63 watts in this scenario. Hence, both of our algorithms gave feasible results with roughly 15% optimality gap.

Fig. 6 compares the performance of our algorithm with that of “TxPowerMin” approach in low ADC/DAC slope setting. We use the same link gain, bandwidth and traffic demands of Fig. 5 but we use the low power consumption ADC and DAC’s to generate these new figures. Our algorithm performs almost similar to the ‘TxPowerMin’ approach here because the power consumption of these low power ADC & DAC is negligible compared to the transmit power requirement.

B. System power minimization in a multi-hop network

To illustrate the influence of system power minimization in a practical setting of non-contiguous spectrum access, we consider an exemplary scenario of multi-hop networking among fixed devices in the TV white space channels of Wichita, Kansas, USA. We use

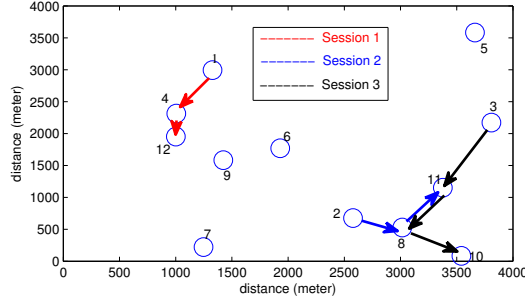

Fig. 7: Twelve node three session multi-hop network.

standard spectrum databases [37] to find the available TV channels in Wichita, Kansas. Fig. 7 shows the locations of nodes. Node 1, 2 and 3 transmit to node 12, 11 and 10 respectively. Each session requires 10 Mbps data rate. Table IV shows the available channel indexes. Each channel is 6 MHz wide. We consider both large scale fading (with path loss exponent 3) and small scale fading (with 12 dB random fluctuation) in each channel. Maximum allowed transmission power is 4 watts [19].

1) *Channel Indexing Notations in Optimization Formulation:* The difference between channel’s carrier frequencies in TV bands are not always proportional to the index differences. Channel 17’s center frequency is $((23 - 17) * 6)$ 36 MHz far from that of channel 23 but not $((17 - 6) * 6)$ 66 MHz far from that of channel 6. The spectrum span calculation of our optimization formulations depends heavily on the coherence of channel indexing differences. Therefore, we use an index set of $\{9, 13, 14, 81, 87, 88, 111\}$ to denote the channel list of $\{2, 5, 6, 17, 23, 24, 47\}$ in the optimization formulations. We use the original channel list to show the numerical results.

2) *Comparison of “waterfilling” algorithm and our approach:* Here, we use the low slope ADC and DAC models of Fig. 9b and Fig. 9a. We also use Hou and Shi’s algorithm [7] to illustrate the scheduling and power control decisions of ‘TxPowerMin’ approach.

Table. V compares the channel scheduling decisions and spectrum spans of “TxPowerMin” approach and our algorithm. Although “TxPowerMin” minimizes transmit power by selecting channels with better quality, it increases radio front end power by selecting channels that are too far apart. Our approach spans narrow spectrum and reduces circuit power consumption. Fig. 8 shows that our algorithm reduces system power by 30%.

The 30% system power saving achieved here was obtained with the low slope ADC and DAC models of Fig. 9b and Fig. 9a - termed as “ultra low power ADC” and “low power

Node	Mode	TxPowerMin		BnBSysPowerMin	
		Channel Index	Spectrum Span (MHz)	Channel Index	Spectrum Span (MHz)
1	Tx	{23, 47}	150	{17, 23}	42
	Rx	{ \emptyset }	0	{ \emptyset }	0
2	Tx	{17}	6	{23}	6
	Rx	{ \emptyset }	0	{ \emptyset }	0
3	Tx	{6, 47}	592	{5, 6}	12
	Rx	{ \emptyset }	0	{ \emptyset }	0
4	Tx	{17}	6	{6}	6
	Rx	{23, 47}	150	{17, 23}	42
8	Tx	{2, 23}	476	{2, 47}	620
	Rx	{5, 24}	460	{17, 23, 24}	48
10	Tx	{ \emptyset }	0	{ \emptyset }	0
	Rx	{23}	6	{47}	6
11	Tx	{5, 24}	460	{17, 24}	48
	Rx	{2, 6, 47}	620	{2, 5, 6}	34
12	Tx	{ \emptyset }	0	{ \emptyset }	0
	Rx	{17}	6	{6}	6

TABLE V: Comparison between the spectrum span of ‘TxPowerMin’ and our ‘BnBSysPowerMin’ algorithm in the network of Fig. 7.

DAC” by their maker, Texas Instruments. Had we used the high slope ADC and DAC models of Fig. 9b and Fig. 9a, our algorithm would have saved system power by a much higher amount in this simulation. In the future, even if the power consumption curves of ADC and DAC become flatter, our algorithm will reduce the system power considerably as long as the number of available channels is sparsely located – which is often the case in a cognitive radio network.

The lower bound of system power consumption is 24 watts in this scenario. Our algorithm provides a feasible solution (29 watts) with 20% optimality gap.

VI. CONCLUSION

Wireless transmission using non-contiguous chunks of spectrum is becoming increasingly essential. MC-MR and NC-OFDMA are the two commercially viable choices to access these non-contiguous spectrum chunks. Fixed MC-MRs do not scale with increasing number of non-

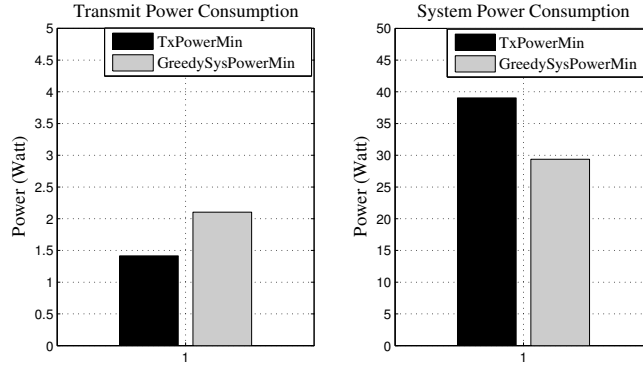

Fig. 8: Performance comparison of “TxPowerMin” approach and our algorithm in the network of Fig. 7, based on the low slope ADC and DAC models of Fig. 9b and 9a.

contiguous spectrum chunks. NC-OFDMA accesses non-contiguous spectrum chunks with a single front end radio but increases circuit power consumption by spanning wider spectrum. Our approach characterized this trade-off and performed joint power control, channel scheduling, spectrum span selection and routing to minimize system power consumption in an NC-OFDMA based multi-hop network. Our algorithm showed how the slopes of ADC and DAC’s power consumption versus sampling rate curves influence the scheduling decisions of a multi-hop network. Numerical results suggested that our algorithm can save 30% system power over classical transmission power based cross-layer algorithms in single front end radios. We developed a branch-and-bound based mixed integer linear programming model to optimize the cross-layer decisions of a general multi-hop network. Furthermore, we also provided a low complexity ($O(E^2M^2)$) greedy algorithm.

The optimal fragmentation results presented here have only accounted for the radio front end power and transmitters’ emitted power. Future work will incorporate baseband power in the optimization formulation.

We focused on system power consumption of single front end radio in this work. A multi-front end programmable radio can dynamically switch its multiple set of center frequencies and access several spectrum chunks in each radio front end with less spectrum span by using NC-OFDMA technology [38]. In the future, we will focus on optimal system power consumption of multi-front end radios.

VII. ACKNOWLEDGEMENTS

This work is supported by the Office of Naval Research under grant N00014-11-1-0132. We thank Dr. Howard, Dr. Ackland and Dr. Samardzija for their feedback regarding system power consumption models.

APPENDIX A

POWER CONSUMPTION OF DIFFERENT BLOCKS IN TRANSMITTER AND RECEIVER

Based on Fig. 2, power consumption of transmitter and receiver are:

$$p_{tc} = p_{dac} + p_{tfilt} + p_{mix} + p_{pa} \quad (33)$$

$$p_{rc} = p_{adc} + p_{rfilt} + p_{mix} + p_{ifa} + p_{lna}. \quad (34)$$

In the above, p_{dac} , p_{mix} , p_{pa} , p_{adc} , p_{ifa} and p_{lna} denote the circuit power consumption in the DAC, mixer, PA, ADC, IFA and LNA respectively. p_{tfilt} and p_{rfilt} represent the summation of circuit powers in the filters of transmitter and receiver respectively.

The power consumption in the mixer, LNA and IFA are constants with respect to the sampling rate [30]. Baseband filter power depends on sampling rate but we assume it to be constant due to its low power consumption [14]. Let us assume,

$$p_{tfilt} + p_{mix} = k_t, \quad p_{rfilt} + p_{mix} + p_{ifa} + p_{lna} = k_r \quad (35)$$

DAC and ADC power consumptions are affine functions of sampling rate [14]. Hence,

$$p_{dac} = k_1 + k_2fs, \quad p_{adc} = k_3 + k_4fs \quad (36)$$

Now, using(36) and (35) in (33) and (34).

$$p_{tc} = k_1 + k_2fs + k_t = \alpha_1 + \alpha_2fs, \quad p_{rc} = k_3 + k_4fs + k_r = \beta_1 + \beta_2f \quad (37)$$

In the above equation, $\alpha_1 = k_1 + k_t$, $\beta_1 = k_3 + k_r$, $\alpha_2 = k_2$ and $\beta_2 = k_4$.

We assume low power consumption at these blocks and use the following values [14]: $p_{tfilt} = 5$ mW, $p_{mix} = 30.3$ mW, $p_{rfilt} = 7.5$ mW, $p_{ifa} = 3$ mW, $p_{lna} = 20$ mW.

Due to its dependence on transmit power, we do not include programmable amplifier's circuit power consumption term p_{pa} in the overall circuit power consumption equations of (33) and (34). Instead, we couple it with the transmit power consumption p and include it in the total power equations of (2) and (3).

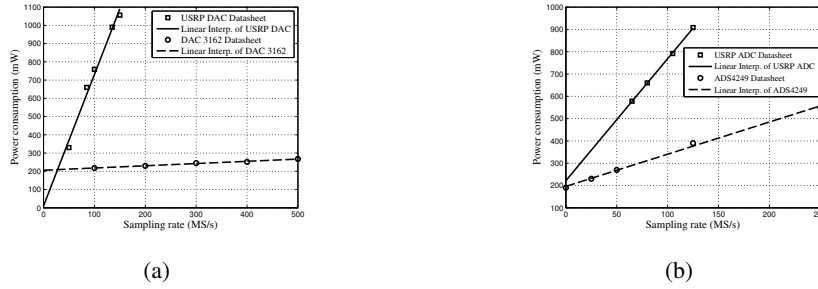

Fig. 9: (a) Power consumption of AD 9777 [16] (DAC of USRP radio) and DAC 3162 [40]. (b) Power consumption of ADS 62P4 [17] (ADC of USRP radio) and ADS 4249 [41]

A. Power consumption of programmable amplifier

Power consumption of programmable amplifier is, $p_{pa} = \frac{PAPR}{\eta} p$. We assume a class-B or a higher class (C, D or E) amplifier with $\eta = 0.75$ [14].

We consider OFDM to be our modulation scheme. The authors of [39] have related the PAPR with the number of subcarriers in OFDM systems as:

$$Prob\{PAPR > \gamma\} \approx 1 - exp\{-Ne^{-\gamma} \sqrt{\frac{\pi}{3}} \gamma\} \quad (38)$$

where N is the number of subcarriers.

In the presence of large number of subcarriers, the statistical distribution of the PAPR does not remain sensitive to the increase of the number of subcarriers [39]. During the simulations, we consider the worst case PAPR by assuming maximum possible spectrum span and highest number of subcarriers. We plug the value of maximum number of possible subcarriers of TV white space in (38), and assume $\gamma = 0.005$ and a 3-4 dB reduction in PAPR. Based on these calculations, we find PAPR to be around 9 dB.

B. Power consumption of ADC and DAC

Fig. 9a plots the power consumption vs. sampling rate curve of AD 9777 [16] (DAC of USRP radio) and DAC 3162 [40]. Fig. 9b plots the power consumption vs. sampling rate curve of ADS62P4 [17] (ADC of USRP radio) and ADS4249 [41]. We obtain specific values of k_1 , k_2 , k_3 and k_4 from these plots.

REFERENCES

- [1] M. N. Islam, A. Sampath, A. Maharshi, O. Koymen, and N. B. Mandayam, "Wireless backhaul node placement for small cell networks," in *Proc. IEEE CISS' 2014*, 2014, pp. 1–6, Mar.

- [2] C. Cordeiro, K. Challapali, D. Birru, and S. Shankar, "IEEE 802.22: the first worldwide wireless standard based on cognitive radios," in *Proc. IEEE DySPAN'2005*, Nov. 2005, p. 328337.
- [3] "Enabling innovative small cell use in 3.5 GHZ band NPRM & order," accessed January 2016, <http://www.fcc.gov/document/enabling-innovative-small-cell-use-35-ghz-band-nprm-order>.
- [4] M. Kodialam and T. Nandagopal, "Characterizing the capacity region in multi-radio multi-channel wireless mesh networks," in *Proc. ACM MOBICOM' 2005*, Aug. 2005, pp. 73–87.
- [5] P. Kyasanur and N. H. Vaidya, "Capacity of multi-channel wireless networks: impact of number of channels and interfaces," in *Proc. ACM MOBICOM' 2005*, Aug. 2005, pp. 43–57.
- [6] Kristoffer Fredriksson and Mattias Guhl, "Multi-channel, multi-radio in wireless mesh networks," M.S. thesis, Chalmers Institute of Technology, Goteborg, Sweden, 2011.
- [7] Y. Shi and Y. T. Hou, "Optimal power control for multi-hop software dened radio networks," in *Proc. IEEE INFOCOM'2007*, May 2007, pp. 1694–1702.
- [8] Y. Shi, T. Hou, S. Kompella, and H. Sherali, "Maximizing capacity in multihop cognitive radio networks under the SINR model," *IEEE Transactions on Mobile Computing*, vol. 10, pp. 954–967, 2011.
- [9] Y. Shi and T. Hou, "A distributed optimization algorithm for multi-hop cognitive radio networks," in *Proc. IEEE INFOCOM' 2008*, 2008, pp. 1292 – 1300.
- [10] M. N. Islam, N. B. Mandayam, and S. Kompella, "Optimal resource allocation and relay selection in bandwidth exchange based cooperative forwarding," in *Proc. IEEE WiOpt'2012*, May 2012, pp. 192–199.
- [11] H. Xu and B. Li, "Efficient resource allocation with flexible channel cooperation in OFDMA cognitive radio networks," in *Proc. IEEE INFOCOM'2010*, Mar. 2010, pp. 1–9.
- [12] L. Yang, B. Y. Zhao, and H. Zheng, "The spaces between us: Setting and maintaining boundaries in wireless spectrum access," in *Proc. ACM MOBICOM 2010*, Sept. 2010, pp. 37–48.
- [13] L. Yang, W. Hou, L. Cao, B. Y. Zhao, and H. Zheng, "Supporting demanding wireless applications with frequency-agile radios," in *Proc. 7th USENIX conference on Networked Systems Design and Implementation*, Apr. 2010, pp. 1–5.
- [14] S. Cui, A. Goldsmith, and A. Bahai, "Energy-constrained modulation optimization," *IEEE Transactions on Wireless Communications*, vol. 4, pp. 2349 – 2360, SEP 2005.
- [15] "ADC performance evolution: Walden figure-of-merit (fom)," accessed January 2016, <http://converterpassion.wordpress.com/2012/08/21/>.
- [16] "AD9777: 16-bit interpolating dual dac converter," accessed January 2016, <http://www.analog.com/media/en/technical-documentation/data-sheets/AD9777.pdf>.
- [17] "Dual channel, 14-bits, 125/105/80/65 MSPS ADC with DDR LVDS/CMOS outputs," accessed January 2016, <http://www.ti.com/lit/ds/symlink/ads62p42.pdf>.
- [18] "AD9467: 16-bit, 200 MSPS/250 MSPS Analog-to-Digital converter," accessed January 2016, <http://www.analog.com/media/en/technical-documentation/data-sheets/AD9467.pdf>.
- [19] C. Gerami, N. B. Mandayam, and L. J. Greenstein, "Backhauling in TV white spaces," in *Proc. IEEE GLOBECOM'2010*, 2010, pp. 1–6, Dec.
- [20] G. Li, Z. Xu, C. Xiong, C. Yang, S. Zhang, Y. Chen, and S. Xu, "Energy-efficient wireless communications: tutorial, survey, and open issues," *IEEE Transactions on Wireless Communications*, vol. 18, pp. 28–35, 2011.
- [21] P. Grover, K. A. Woyach, and A. Sahai, "Towards a communication-theoretic understanding of system-level power consumption," *IEEE Journals on Selected Areas in Communications*, vol. 29, pp. 1744 – 1755, SEP 2011.
- [22] C. Isheden and G. P. Fettweis, "Energy-efficient multi-carrier link adaptation with sum rate-dependent circuit power," in *Proc. IEEE GLOBECOMM' 2010*, Dec. 2010, pp. 1–6.

- [23] J. Jia and W. Zhuang, "Capacity of multi-hop wireless network with frequency agile software defined radio," in *Proc. IEEE INFOCOM Workshop on Cognitive & Cooperative Networks*, Apr. 2011, pp. 41–46.
- [24] L. Cao, L. Yang, and H. Zheng, "The impact of frequency-agility on dynamic spectrum sharing," in *Proc. IEEE DySPAN 2010*, Apr. 2010, pp. 1–12.
- [25] Y. P. Lin and P. P. Vaidyanathan, "Periodically nonuniform sampling of bandpass signals," *IEEE Transactions on Circuits and Systems II*, vol. 45, pp. 340–351, 1998.
- [26] M. Mishali and Y. C. Eldar, "Sub-nyquist sampling," *IEEE Signal Processing Magazine*, vol. 28, pp. 98–124, 2011.
- [27] L. Yang, Z. Zhang, W. Hou, B. Y. Zhao, and H. Zheng, "Papyrus: A software platform for distributed dynamic spectrum sharing using sdrs," *ACM SIGCOMM Computer Communications Review*, vol. 41, pp. 31–37, 2011.
- [28] W. Hou, L. Yang, L. Zhang, X. Shan, and H. Zheng, "Understanding the impact of cross-band interference," in *Proc. ACM Workshop on Cognitive Radio Networks*, Sept. 2009, pp. 19–24.
- [29] H. C. Liu, J. S. Min, and H. Samueli, "A low-power baseband receiver IC for frequency-hopped spread spectrum communications," *IEEE J. Solid-State Circuits*, vol. 31, pp. 384–394, mar 1996.
- [30] Y. Li, B. Bakaloglu, and C. Chakrabarti, "A system level energy model and energy-quality evaluation for integrated transceiver front-ends," *IEEE Transactions on VLSI Systems*, vol. 15, pp. 90–103, 2007.
- [31] H. D. Sherali and W. P. Adams, *A Reformulation-Linearization Technique for Solving Discrete and Continuous Nonconvex Problems*, Kluwer Academic Publishers, Dordrecht/Boston/London, 1999.
- [32] "CVX: Matlab software for disciplined convex programming," accessed January 2016, <http://cvxr.com/cvx/>.
- [33] "Mosek optimization," accessed January 2016, <http://www.mosek.com/>.
- [34] T. M. Cover and J. A. Thomas, *Elements of Information Theory*, John Wiley and Sons, Hoboken, NJ, 2005.
- [35] T. H. Cormen, C. E. Leiserson, R. L. Rivest, and C. Stein, *Introduction to Algorithms*, The MIT Press, Cambridge, MA, 2009.
- [36] S. Boyd and L. Vandenberghe, *Convex Optimization*, Cambridge University Press, Cambridge, MA, 1999.
- [37] "Show my white space," accessed January 2016, <http://whitespaces.spectrumbridge.com/whitespaces>.
- [38] G. Fettweis, M. Krondorf, and S. Bittner, "GFDM - generalized frequency division multiplexing," in *Proc. IEEE VTC'2009*, 2009, pp. 1–4.
- [39] H. Ochiai and H. Imai, "On the distribution of peak-to-average power ratio in OFDM signals," *IEEE Transactions on Communications*, vol. 49, pp. 282–289, 2001.
- [40] "Dual-Channel, 10/12 Bit, 500 MSPS Digital-to-Analog converters," accessed January 2016, <http://www.ti.com/lit/ds/symlink/dac3162.pdf>.
- [41] "Dual-Channel, 14-Bit, 250-MSPS Ultralow-Power ADC," accessed January 2016, <http://www.ti.com/lit/ds/symlink/ads4249.pdf>.