

Secrecy Transmission on Parallel Channels: Theoretical Limits and Performance of Practical Codes

Marco Baldi, *Senior Member, IEEE*, Franco Chiaraluce, *Member, IEEE*, Nicola Laurenti,
Stefano Tomasin, *Senior Member, IEEE*, and Francesco Renna, *Member, IEEE*

Abstract

We consider a system where an agent (Alice) aims at transmitting a message to a second agent (Bob) over a set of parallel channels, while keeping it secret from a third agent (Eve) by using physical layer security techniques. We assume that Alice perfectly knows the set of channels with respect to Bob, but she has only a statistical knowledge of the channels with respect to Eve. We derive bounds on the achievable outage secrecy rates, by considering coding either within each channel or across all parallel channels. Transmit power is adapted to the channel conditions, with a constraint on the average power over the whole transmission. We also focus on the maximum cumulative outage secrecy rate that can be achieved. Moreover, in order to assess the performance in a real life scenario, we consider the use of practical error correcting codes. We extend the definitions of security gap and equivocation rate, previously applied to the single additive white Gaussian noise channel, to Rayleigh distributed parallel channels, on the basis of the error rate targets and the outage probability. Bounds on these metrics are also derived, taking into account the statistics of the parallel channels. Numerical results are provided, that confirm the feasibility of the considered physical layer security techniques.

Manuscript received ***; revised ***.

M. Baldi and F. Chiaraluce are with the Dipartimento di Ingegneria dell'Informazione, Università Politecnica delle Marche, 60131 Ancona, Italy. N. Laurenti and S. Tomasin are with the Department of Information Engineering, University of Padua, 35131 Padua, Italy. F. Renna is with the Instituto de Telecomunicações e Departamento de Ciência de Computadores, Faculdade de Ciências da Universidade do Porto, 4169-007, Porto, Portugal

This work was supported in part by the Italian Ministry of Education and Research (MIUR) project ESCAPADE (Grant RBFR105NLC) under the "FIRB-Futuro in Ricerca 2010" funding program.

Index Terms

Coding, outage probability, parallel channels, physical layer security.

I. INTRODUCTION

Performance of physical layer security schemes can be assessed either by evaluating their achievable secrecy rates – which assume, among other things, ideal coding (e.g., Gaussian codewords with infinite length) – or focusing on practical codes and considering the error probabilities for both the legitimate receiver and the eavesdropper.

Within the former approach, the ergodic secrecy capacity for a fast fading scenario is derived in [1] by maximizing the ergodic secrecy rate over all power allocations that meet an average transmit power constraint. A compound parallel Gaussian wiretap channel, in which the main channel gains are known to all parties, while the eavesdropper gains can take any value within a given finite set, is considered in [2], where a max-min coding strategy is proved to achieve secrecy capacity. In the block fading scenario of [3], only statistics of both the legitimate receiver and the eavesdropper channels are assumed to be known at the transmitter. Then, a secrecy throughput is evaluated, that is achieved either with repetition coding or with a single wiretap channel code over a finite number of fading blocks. On the other hand, it is necessary to take into account the probability that, for a certain fraction of time, the transmission becomes either unreliable (reliability outage) or insecure (secrecy outage). The statistical distribution of the secrecy capacity and the low-rate limit on the secrecy outage probability are derived in [4], [5] for a set of independently faded parallel wiretap channels, thus modeling orthogonal frequency division multiplexing (OFDM) transmissions. In [6], perfect channel state information (CSI) for the main channel and statistical CSI for the eavesdropper channel are assumed: for a fast Rayleigh fading wiretap channel with a multi-antenna transmitter and a single antenna device for both the intended receiver and the eavesdropper (MISOSE channel), the ergodic secrecy rate is optimized through an artificial noise injection scheme. Similarly, [7] fully characterizes the ergodic secrecy capacity of the MISOSE channel under statistical CSI for both the main and the eavesdropper channels.

Very few examples of practical codes over (different kinds of) wiretap channels have been studied in previous literature. Most of these papers aim at finding codes able to achieve the

secrecy capacity. This problem has been solved for the binary erasure channel (BEC), where low-density parity-check (LDPC) codes have been considered [8], and for the binary symmetric channel (BSC), where polar codes have been proposed [9]. More recently, polar codes have also been included in a key agreement protocol over block fading channels [10]. Polar coding, however, has been shown to be optimal over discrete memoryless channels, while our focus is on continuous-output channel models, which are best suited to model wireless transmissions.

To the best of the authors knowledge, at this time no code is available that ensures information theoretic secrecy, even asymptotically (e.g., in one of the criteria listed in [11]) over continuous output channels; therefore, other secrecy metrics must be considered. A first step toward practical scenarios is provided by the equivocation rate [12], that still considers information leakage as a security metric, while taking into account the rate that can be reliably decoded by Bob with practical codes. However, it is still assumed that Eve may get an information rate equal to her channel capacity. When this assumption is removed and the error rate that can be achieved even by Eve is taken into account, an interesting metric is the *security gap* [13], that compares the signal-to-noise ratios (SNRs) on the main and the eavesdropper channels required to achieve both a sufficient level of secrecy and reliable decoding by the authorized receiver. In other words, the security gap is the required legitimate receiver power margin for having both a sufficiently high probability that he correctly receives the transmitted message and a sufficiently high probability that the message is not gathered by an eavesdropper. The security gap metric has been applied in [14] to punctured LDPC codes and in [15]–[17] to non-systematic codes, including LDPC codes and classical Bose-Chaudhuri-Hocquenghem (BCH) codes. Practical codes for physical layer security have also been applied over the packet erasure channel [18], where some properties of stopping sets are exploited to achieve secrecy with punctured non-systematic LDPC codes. However, to the best of our knowledge, the evaluation of secrecy capabilities, with the security gap metric, for practical codes over parallel channels has never been faced in previous literature.

In this paper, we consider a parallel channels scenario where a transmitter, Alice, and a legitimate receiver, Bob, have perfect CSI for their link, while Alice only has a statistical description of the link between herself and the eavesdropper, Eve. Both the Alice-Bob and the Alice-Eve links are assumed to be independent identically distributed (i.i.d.) Rayleigh parallel channels, modeling for example an OFDM transmission over independently faded subcarriers. As the channel gains are represented by continuous random variables, the compound parallel

Gaussian wiretap channel model [2] does not apply. Moreover, transmission is performed over a finite set of parallel channels, thus preventing the leverage of ergodicity for the fading wiretap channel [1]. Therefore, the transmission scenario implies a nonzero secrecy outage probability [19], and we aim at maximizing the secrecy rates while satisfying a constraint on the secrecy outage probability.

Two approaches are considered for the transmission of a message by Alice: in one case, the message is first split into sub-messages, each separately encoded and transmitted on a different channel; in the other case, the message is encoded into a single codeword which is split into sub-words, each transmitted on a different channel. The first case is denoted as *coding per sub-message* (CPS), while the second one is denoted as *coding across sub-messages* (CAS). This distinction is similar to the one between *variable* and *constant rate* transmission in [1]. However, in [1] codewords are assumed to span all the possible fading states, thus reducing it to an ergodic scenario. Here instead we consider a finite set of parallel channels, thus taking into account the possibility of secrecy outage. The performance of the proposed scheme is assessed both by information theoretical arguments and by evaluation of the error rates with existing practical codes.

The main contributions of the paper are:

- the derivation of achievable secrecy rates for transmissions over independent Rayleigh distributed parallel channels subject to a secrecy outage probability constraint;
- the joint optimization of power and rate allocation among sub-messages for secrecy rate maximization subject to a constraint on the maximum secrecy outage probability, where the compound parallel Gaussian wiretap channel model [2] cannot be applied;
- the derivation of closed-form expressions of the outage secrecy rates for both CPS and CAS scenarios, otherwise previously available only by Monte Carlo methods [3];
- the non-trivial performance comparison between CPS and CAS, since their outage secrecy rates are not immediately comparable;
- the derivation of bounds on the error rates for Bob and Eve with practical codes on Rayleigh distributed parallel channels;
- the extension of the security gap and the equivocation rate metrics from a single additive white Gaussian noise (AWGN) channel to Rayleigh distributed parallel channels.

The paper is organized as follows. In Section II we introduce the system model, and in Section

III we derive theoretical bounds on the achievable rates, for both CPS and CAS. In Section IV we use the error rate as a different metric to assess the physical layer security on parallel channels, when practical codes are applied. Section V provides several numerical examples, and Section VI concludes the paper.

II. SYSTEM MODEL

Let us consider a scenario with K parallel wiretap channels with independent Rayleigh distributed fading and AWGN. We denote by h_k the complex (baseband equivalent) channel coefficient between Alice and Bob upon transmission over the channel $k = 1, 2, \dots, K$, and g_k the corresponding channel coefficient between Alice and Eve. Both coefficients are assumed to be constant for the duration of a transmission. The power gains $H_k = |h_k|^2$, and $G_k = |g_k|^2$ are independent exponentially distributed random variables with means α_B and α_E , respectively. The thermal noise variance of all channels is normalized to one. Let us define the vectors $\mathbf{H} = [H_1, \dots, H_K]$ and $\mathbf{P} = [P_1, \dots, P_K]$, where P_k is the power transmitted by Alice over the k -th channel.

In the following, we will refer to the notion of *secrecy rate*, that is a transmission rate for which, in the asymptotic regime of infinite codeword length, it is possible to guarantee that the error probability at Bob's receiver approaches zero (*reliability condition*) and that mutual information between the transmitted message and the signal received by Eve is arbitrarily small (*strong secrecy condition*, as formally defined in, e.g., [20, Sec. 3.3]). Secrecy and reliability can be ensured if Alice has CSI on channels to both Bob and Eve. However, as better explained in the following, Alice is assumed to know only the statistical description of the channel coefficients g_k . In this case, using a code with a given secrecy rate may lead to some information leakage to Eve (depending on channel conditions), i.e., to a *secrecy outage* [19] event.

As stated in Section I, two coding approaches are considered:

Coding per sub-message (CPS): In this case, Alice first splits the message into K sub-messages; each of them is then encoded into a different codeword and transmitted over a different channel, as shown in Fig. 1. The secrecy rate for sub-message $k = 1, 2, \dots, K$ is R_k . In other terms, each sub-message is encoded independently using a wiretap channel code with secrecy rate R_k , where $\sum_{k=1}^K R_k$ is the total message rate.

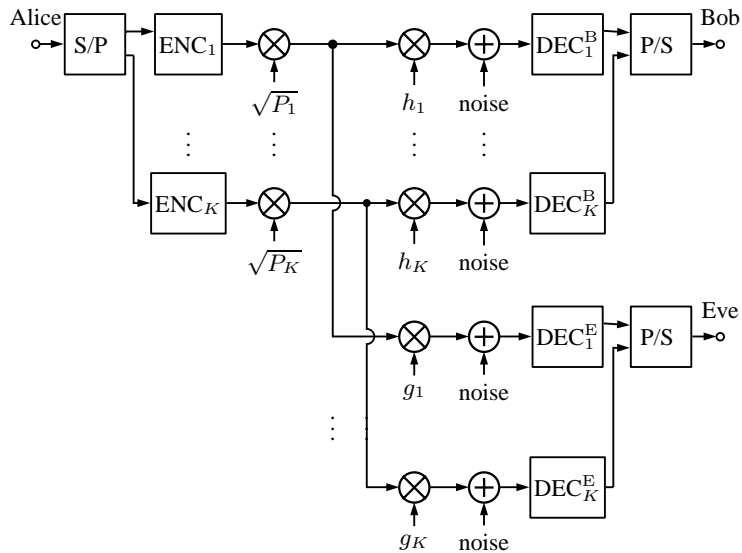

Fig. 1. System model for CPS. S/P: serial to parallel; P/S: parallel to serial.

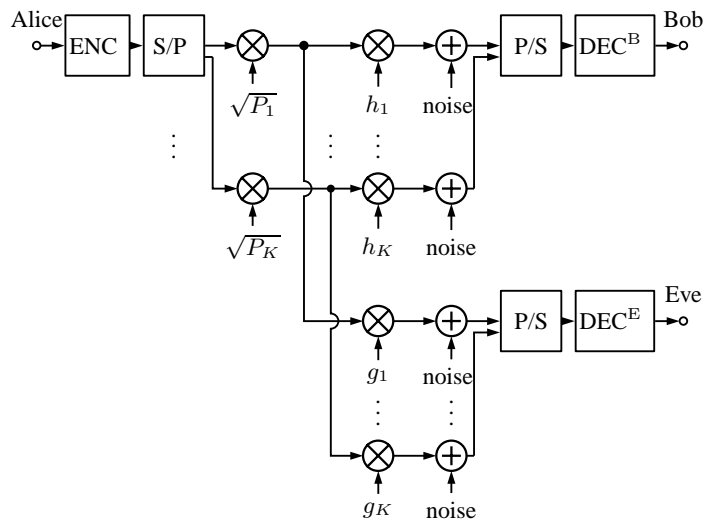

Fig. 2. System model for CAS.

Coding across sub-messages (CAS): In this case, the message is first encoded into a single codeword and then transmitted over the K parallel channels, as shown in Fig. 2. The secrecy rate of the message is denoted as R .

In this paper we investigate the two schemes when a transmission spans a finite set of channel realizations and Alice does not have CSI of the channel to Eve. Then, secrecy conditions may be

not satisfied and the outage probability is considered as a performance metric together with the secrecy rate. We will see that also in this scenario the performance of the two schemes differ.

We first observe that CPS is a special case of CAS, where a specific encoding procedure (splitting data and encoding them separately) is enforced. In this respect, we expect CAS to outperform CPS. On the other hand, when full CSI on both the main and eavesdropper channel is available at the transmitter, the two schemes achieve the same performance [21], [22]. Then, it is interesting to see the performance gap when Alice has full CSI on the channel to Bob, and only partial CSI on the channel to Eve. Moreover, when a finite message of fixed size is considered, the code length in CAS is larger than in CPS, thus providing an advantage for CAS. On the other hand, choosing a CPS scheme yields a parallel implementation of encoding and decoding, allowing the use of solutions devised for AWGN channels. Because of the advantages and limits of each scheme, it is difficult to establish the superiority of one solution over the other in absolute terms.

III. SECRECY PERFORMANCE BOUNDS WITH IDEAL CODES

We suppose that Alice knows the channel with respect to Bob before transmission, while the Alice-Eve channel is known only in statistical terms¹. This is a very realistic assumption, since in most of the practical cases Alice does not know the eavesdropper precise location. On the other hand, the Alice-Bob channel state can be learned by conventional channel estimation techniques. Note that we assume that each channel is constant for the whole duration of the transmission, thus allowing for its estimation. A relevant practical example is OFDM, where the assumption of i.i.d. gains over the parallel channels can be met by considering ideal interleaving across sub-carriers separated by significantly more than the channel coherence bandwidth [23, p. 101].

Due to partial CSI by Alice on her channel to Eve and to the fact that a finite number K of fading states are spanned by each transmission, we cannot ensure strong secrecy. Instead, we impose that the probability that Eve gets non vanishing information on the secret message (*strong secrecy outage probability*) is below a given threshold ε .

¹In Appendix C we consider the case where also the Alice-Bob channel is known only statistically.

In this section we focus on ideal codes, i.e., codes with infinite code length and Gaussian codewords. We aim at allocating power over the channels for the two coding schemes in order to maximize the secrecy rate while ensuring the target outage probability.

Constrained Secrecy Rate Maximization Problem for CPS: Let us define the vector of secrecy rates $\mathbf{R} = [R_1, \dots, R_K]$ and let

$$p_s(\mathbf{P}, \mathbf{R}; \mathbf{H}) = \mathbb{P} \left[\bigcup_{k=1}^K \{ \log(1 + H_k P_k) - \log(1 + G_k P_k) \leq R_k \} \right] \quad (1)$$

be the secrecy outage probability, i.e., the probability that any of the K channels is in secrecy outage. In (1), $\log(\cdot)$ denotes the base-2 logarithm and $\mathbb{P}[\cdot]$ the probability operator, in this case with respect to the random variable G_k , while H_k is known. The following constraints must be satisfied on \mathbf{R} and \mathbf{P}

$$p_s(\mathbf{P}, \mathbf{R}; \mathbf{H}) \leq \varepsilon, \quad (2a)$$

$$\frac{1}{K} \sum_{k=1}^K P_k \leq P_{\max}, \quad (2b)$$

$$P_k \geq 0, \quad k = 1, 2, \dots, K, \quad (2c)$$

$$R_k \geq 0, \quad k = 1, 2, \dots, K. \quad (2d)$$

Constraint (2a) sets the maximum allowed secrecy outage probability to ε ; constraint (2b) imposes a bound on the average transmit power to P_{\max} , while (2c) and (2d) ensure that the resulting powers and rates are non-negative. Now, we aim at finding the maximum average outage secrecy rate [19] that can be achieved, as the solution of the following problem

$$\max_{\{P_k, R_k\}} \sum_{k=1}^K R_k, \quad (3)$$

subject to (2).

Constrained Secrecy Rate Maximization Problem for CAS: For CAS, coding is performed by Alice across the K sub-messages. For a given realization of Bob's channel values (H_1, \dots, H_K) , the secrecy outage probability with respect to the random (and unknown to Alice) gains in Eve's channel can be written as [1]

$$p_s(\mathbf{P}, \mathbf{R}; \mathbf{H}) = \mathbb{P} \left[\sum_{k=1}^K \log(1 + H_k P_k) - \sum_{k=1}^K \log(1 + G_k P_k) \leq R \right]. \quad (4)$$

Constraint (2a) becomes

$$p_s(\mathbf{P}, R; \mathbf{H}) \leq \varepsilon, \quad (5a)$$

and (2d) becomes

$$R \geq 0, \quad (5b)$$

while the other constraints remain unchanged. The maximization problem becomes

$$\max_{\{P_k, R\}} R, \quad (6)$$

subject to (2b)-(2c) and (5).

Note that the constrained maximization problems differ from the conventional bit and power loading for insecure transmission due to the presence of the security constraint. Therefore, the waterfilling solution is not optimal in this case, as will be confirmed by numerical results in Section V.

A. Coding Per Sub-Message

With CPS each sub-message is encoded independently of the others, with a target secrecy rate R_k . Secrecy outage is experienced when at least one of the K sub-messages transmitted over the different channels is in outage. Therefore, the secrecy outage probability in (1) is given by

$$p_s(\mathbf{P}, \mathbf{R}; \mathbf{H}) = 1 - \prod_{k=1}^K (1 - p_k), \quad (7)$$

where p_k is the secrecy outage probability for sub-message k , given that the corresponding realization of H_k is known, i.e.,

$$\begin{aligned} p_k &= \mathbb{P}[\log(1 + H_k P_k) - \log(1 + G_k P_k) \leq R_k] \\ &= \begin{cases} 1, & R_k > \log(1 + H_k P_k) \\ 1 - F_G\left(\frac{1 + H_k P_k}{P_k 2^{R_k}} - \frac{1}{P_k}\right), & \text{otherwise,} \end{cases} \end{aligned} \quad (8)$$

where $F_G(x)$ denotes the cumulative distribution function (CDF) of the eavesdropper power gain G_k over the k -th channel, which is the same for all channels.

If for some k we have $R_k > \log(1 + H_k P_k)$, then the CPS system is always in outage. Otherwise, by the assumption of i.i.d. Rayleigh channel gains, with simple algebra we obtain

$$\begin{aligned} p_s(\mathbf{P}, \mathbf{R}; \mathbf{H}) &= 1 - \\ &\prod_{k=1}^K \left\{ 1 - \exp\left[-\frac{1}{\alpha_E} \left(\frac{1 + H_k P_k}{P_k 2^{R_k}} - \frac{1}{P_k}\right)\right] \right\}. \end{aligned} \quad (9)$$

Note that the secrecy outage probability for each sub-message k is a function of both the power P_k and the target secrecy rate R_k . Therefore, the rate maximization problem (3) cannot be formulated as a special instance of the compound parallel Gaussian wiretap channel [2], since the allocation of the target secrecy rates R_k adds K variables to the rate maximization problem. In fact, constraint (2a) can be met by different rate K -tuples. The secrecy rates R_k are related to the transmit power. In particular, if we restrict the constraints (2c)–(2d) to hold without equality, i.e.,

$$P_k > 0, \quad R_k > 0 \quad (10)$$

and denote by \bar{p}_k the target secrecy outage probability for each sub-message, i.e.,

$$\exp \left[-\frac{1}{\alpha_E} \left(\frac{1 + H_k P_k}{P_k 2^{R_k}} - \frac{1}{P_k} \right) \right] = \bar{p}_k, \quad (11)$$

we obtain the following result.

Theorem 1: For a given K -tuple of outage probabilities $\bar{\mathbf{p}} = (\bar{p}_1, \dots, \bar{p}_K)$ and $\nu > 0$, let us define $\bar{u}_k = -\alpha_E \ln \bar{p}_k$. If $\nu - H_k + \bar{u}_k < 0, \forall k$, then the power allocation

$$P_k = P_k^* = \frac{-\nu(\bar{u}_k + H_k)}{2\bar{u}_k\nu H_k} + \frac{\sqrt{[\nu(\bar{u}_k + H_k)]^2 - 4\bar{u}_k\nu H_k(\nu - H_k + \bar{u}_k)}}{2\bar{u}_k\nu H_k} \quad (12)$$

maximizes the sum-rate (3) under the constraint (10).

Therefore, if ν is such that (2b) is satisfied with equality, $\{P_k^*\}$ is also the power allocation that solves the maximization problem (3), under constraints (2a), (2b) and (10), with secrecy outage probability as in (9). The corresponding secrecy rate of the message is

$$R_s = \sum_{k=1}^K R_k = \sum_{k=1}^K \log \frac{1 + H_k P_k}{\bar{u}_k P_k + 1}. \quad (13)$$

Proof: See Appendix A. ■

From Theorem 1 we conclude that the maximum secrecy rate ensuring a secrecy outage probability not greater than ε is obtained by solving

$$\max_{\bar{\mathbf{p}}, \nu} \sum_{k=1}^K \log \frac{1 + H_k P_k}{\bar{u}_k P_k + 1} \quad (14)$$

subject to $1 - \prod_{k=1}^K (1 - \bar{p}_k) \leq \varepsilon$, (12), (2b), and (10). The solution of these problems requires numerical methods. Note however that Theorem 1 allows a strong reduction in the number of unknowns: from $2K$ in the original problem formulation (3) to $(K + 1)$ in the formulation (14).

B. Coding Across Sub-Messages

We start from (4), which reflects the specific encoding (and decoding) structure of CAS, and in this respect it is different from (1), valid for CPS.

Let

$$\Phi(\mathbf{P}, R; \mathbf{H}) = 2^{\lceil \sum_{k=1}^K \log(1+H_k P_k) - R \rceil} \quad (15)$$

and let us define

$$\varepsilon(\mathbf{P}) = \prod_{k=1}^K e^{\frac{1}{P_k \alpha_E}}, \quad \varphi(\mathbf{P}) = \left[\prod_{k=1}^K \frac{1}{P_k \alpha_E} \right]^{-1}. \quad (16)$$

As derived in Appendix B, the secrecy outage probability (4) can be written as

$$p_s(\mathbf{P}, R; \mathbf{H}) = 1 - \frac{\varepsilon(\mathbf{P})}{\varphi(\mathbf{P})} \times \left\{ \Phi(\mathbf{P}, R; \mathbf{H}) \mathcal{G} \left(\frac{\Phi(\mathbf{P}, R; \mathbf{H})}{\varphi(\mathbf{P})} \right) - \mathcal{G} \left(\frac{1}{\varphi(\mathbf{P})} \right) \right\}, \quad (17)$$

where

$$\mathcal{G}(a) = \mathcal{H}_{1, K+1}^{K, 1} \left[a \left| \begin{array}{c} \{(0, 1, 0)\} \\ \{\{(0, 1, (P_k \alpha_E)^{-1})\}_{k=1, \dots, K}, (-1, 1, 0)\} \} \end{array} \right. \right] \quad (18)$$

and $\mathcal{H}[\cdot]$ is the generalized Fox H-function, whose definition is recalled in Appendix B.

Then (5a) can be rewritten as

$$0 \leq R \leq p_s^{-1}(\mathbf{P}, \varepsilon; \mathbf{H}), \quad (19)$$

where $p_s^{-1}(\mathbf{P}, \varepsilon; \mathbf{H})$ is the inverse of (17) with respect to R .

When the outage secrecy rate is maximized, R equals the right hand side (r.h.s.) in (19); therefore, we can remove R from the optimization variables and the maximum outage secrecy rate problem (6) can be rewritten as

$$\max_{\mathbf{P}} p_s^{-1}(\mathbf{P}, \varepsilon; \mathbf{H}), \quad (20)$$

subject to (2b) and (2c). This problem cannot be solved in closed form and we must resort to numerical methods. Examples will be given in Section V.

IV. SECRECY PERFORMANCE BOUNDS WITH PRACTICAL CODES

The analysis in Section III relies on the use of ideal codes, thus providing an upper bound on the performance reachable by using practical forward error correcting (FEC) codes. Indeed, when long codewords can be used, practical codes (e.g., LDPC codes) may well approximate asymptotic performance achieving results close to capacity. In this context, the transmission rate to Bob that can be obtained with the power allocation \mathbf{P} corresponds to the code rate, while its difference with the outage secrecy capacity provides the rate of the random message to be used in random binning in order to obtain the target secrecy outage probability. However, when limits on the length of the codeword are relevant, due to delay constraints or channel coherence time concerns, other approaches should be considered in the code design. Hence, in order to better assess the performance of finite length practical codes, we gradually introduce the characteristics of a real transmission:

- **Discrete (finite) constellations:** when finite and discrete constellations are used, in the secrecy capacity expression we should consider the constellation-constrained mutual information.
- **Deterministic encoding:** when FEC is used without probabilistic encoding (e.g., random binning) that is typical of wiretap codes, we focus on the amount of information per channel use that remains unknown to Eve, with probability at least $1 - \varepsilon$; we thus introduce the ε -outage equivocation rate, extending the notion given in [12] for AWGN channels.
- **Finite length codes:** with finite length codes, both Bob and Eve are prone to errors and secrecy cannot be assessed by Eve's equivocation only. The metric that suitably summarizes the error probabilities of the two agents is the security gap (used for the AWGN channel in [14]–[17]), as will be defined in Section IV-B.

A. Finite Constellation and Deterministic Encoding

When a finite constellation is considered (still with wiretap coding), let $C(\gamma)$ be the mutual information rate of a Gaussian channel with a fixed (e.g., uniform) distribution as a (monotonically increasing) function of the SNR γ . The expression of $C(\gamma)$ depends on the adopted input constellation.

In this case, for CPS, (8) becomes

$$p_k = \mathbb{P} [C(H_k P_k) - C(G_k P_k) \leq R_k] , \quad (21)$$

thus providing for Rayleigh fading channels

$$p_s(\mathbf{P}, \mathbf{R}; \mathbf{H}) = 1 - \prod_{k=1}^K \left\{ 1 - \exp \left(-\frac{C^{-1}[C(H_k P_k) - R_k]}{P_k \alpha_E} \right) \right\}. \quad (22)$$

Similarly, for CAS, (4) becomes

$$\begin{aligned} p_s(\mathbf{P}, R; \mathbf{H}) &= \mathbb{P} \left[\sum_{k=1}^K [C(H_k P_k) - C(G_k P_k)] \leq R \right] \\ &\leq 1 - \prod_{k=1}^K \left\{ 1 - \exp \left(-\frac{C^{-1}[(\sum_k C(H_k P_k) - R)/K]}{P_k \alpha_E} \right) \right\}, \end{aligned}$$

where the last upper bound is obtained by assuming Rayleigh fading channels and by observing that

$$\sum_{k=1}^K C(G_k P_k) \leq K \max_k C(G_k P_k). \quad (23)$$

The outage secrecy rate obtained under constellation constrained transmission is denoted as $C_s^{(\varepsilon)}$.

Consider now a deterministic encoding without wiretap coding features, with a fixed code rate R_c . In [12] the level of confidentiality obtained in a coded transmission over an AWGN channel is evaluated through its equivocation rate, that is, the difference between the code rate and the information rate at the eavesdropper. The equivocation rate is an indicator of the residual uncertainty of the eavesdropper on the transmitted message. We extend the notion of equivocation rate to the considered scenario through an outage formulation, and derive lower bounds for both CPS and CAS. The code rate R_c and allocated powers $\{P_k\}$ are assumed to satisfy the reliability conditions

$$R_c \leq C(H_k P_k) \quad \forall k \quad \text{for CPS}, \quad (24a)$$

$$R_c \leq \frac{1}{K} \sum_{k=1}^K C(H_k P_k) \quad \text{for CAS}. \quad (24b)$$

Since all information bits are intended for confidential transmission, now R_c plays the role of mutual information between Alice and Bob. In particular, the secrecy outage probabilities have the expressions (22) and (IV-A), where $C(H_k P_k)$ is replaced by R_c . Correspondingly, the ε -outage equivocation rate is the maximum value of $\sum_k R_k$ or R such that the outage probability constraint is satisfied.

B. Finite Length Codes

When codes of finite length are considered, we cannot use the secrecy capacity or the equivocation rate to assess their performance. Instead we have to take into account the non-vanishing error probability incurred by these codes. Let us denote by p^B and p^E the decoding error rate on the entire message received by Bob and Eve, respectively. Given two arbitrarily small threshold values, ρ and η , the transmission can be considered reliable and secure if the following two conditions are satisfied² [14], [17]:

$$p^B \leq \rho, \quad (25a)$$

$$p^E \geq 1 - \eta. \quad (25b)$$

The condition on p^B for CPS can be translated into a condition on the codeword error rate (CER) p_k^B on each sub-message k . We first observe that

$$p^B = 1 - \prod_{k=1}^K (1 - p_k^B). \quad (26)$$

Although in general the maximum secrecy outage rate is achieved with different values of p_k^B for each channel, here we focus on the case of equal error probabilities for each channel, so that (25a) becomes

$$p_k^B \leq 1 - \sqrt[\kappa]{1 - \rho}. \quad (27)$$

For CAS, instead, the condition on p^B directly translates into a condition on the CER, since p^B coincides with the CER in this case. Therefore, we can fix a threshold δ on the CER for the two schemes as follows

$$\begin{cases} p_k^B \leq \delta = 1 - \sqrt[\kappa]{1 - \rho}, & \text{for CPS,} \\ p^B \leq \delta = \rho, & \text{for CAS.} \end{cases} \quad (28)$$

²Note that condition (25b) refers to the decoding error probability. For messages that are not perfectly source-coded (i.e., are not at maximum entropy), non-systematic codes must be used to increase secrecy [14], [17].

Note that, assuming that the secret message is uniformly distributed, perfect secrecy requires that (25b) is satisfied with $\eta = 2^{-NR_s}$ for any decoding strategy, where N is the codeword length. Such condition is also sufficient if it holds in particular for the optimal strategy, that is maximum likelihood (ML) decoding. Similarly, for the rate R_s to be achievable under an information theoretic secrecy criterion of variational distance (e.g., criterion (2) in [11]) it is necessary and sufficient that there exists a sequence of codes with lengths $N \in \mathbb{N}$, such that (25b) is satisfied under ML decoding for each N with $\eta \sim 2^{-NR_s}$ as $N \rightarrow \infty$, while at the same time $\rho \rightarrow 0$ in (25a).

On the contrary, we impose that the CER for Eve always equals or overcomes $1 - \eta$. It is important that this occurs even with CPS, on each channel, since otherwise Eve, though not being able to decode the whole message, could successfully discover some part of it.

Note that condition (25a) can be met through a suitable power allocation, since Bob's channels are known. Condition (25b), instead, can only be met statistically, that is, by tolerating some outage probability, since only a statistical description of Eve's channels is available. The case in which Bob's channels are also known only in statistical terms is studied in Appendix C.

We indicate by γ_δ^B the minimum SNR on each channel that ensures condition (28), that is

$$\gamma_\delta^B(k) = \min \{ \gamma \in \mathbb{R} : \mathbb{P} [E_k^B | P_k H_k = \gamma] \leq \delta \} \quad (29)$$

where E_k^B denotes Bob's decoding error event on channel k for CPS, and

$$\begin{aligned} \gamma_\delta^B = \min \{ \gamma \in \mathbb{R} : \\ \mathbb{P} [E^B | P_1 H_1 = \gamma, \dots, P_K H_K = \gamma] \leq \delta \} \end{aligned} \quad (30)$$

with E^B denoting Bob's decoding error event for CAS. On the other hand, since we assume that Alice does not know Eve's channels, we consider an outage approach for the definition of the security gap. In fact, p^E is a random variable, whose distribution, under the i.i.d. Rayleigh assumption, only depends on the average SNR of Eve's channels, defined as

$$\bar{\gamma}^E = \frac{1}{K} \sum_k \alpha_E P_k. \quad (31)$$

We are interested in finding the maximum value of $\bar{\gamma}^E$, denoted by $\bar{\gamma}_{\max}^E$, for which the probability that $p^E < 1 - \eta$ is not greater than ε . In fact, $\bar{\gamma}_{\max}^E$ represents the maximum average SNR over Eve's channel which is acceptable to meet (25b) under the outage constraint. We have

$$\bar{\gamma}_{\max}^E = \frac{1}{K} \sum_k P_k \max \{ \alpha_E : \mathbb{P} [p^E < 1 - \eta] \leq \varepsilon \}. \quad (32)$$

Aiming to extend the original definition of security gap given for the AWGN channel in [13] to the considered scenario, we define the ε -outage security gap as

$$S_\varepsilon = \begin{cases} \frac{\sum_{k=1}^K \gamma_\delta^B(k)}{K \bar{\gamma}_{\max}^E} & \text{for CPS,} \\ \frac{\gamma_\delta^B}{\bar{\gamma}_{\max}^E} & \text{for CAS.} \end{cases} \quad (33)$$

It has to be observed that the security gap defined by (33) is computed on the basis of the codeword error rate, and does not depend on the bit error rate of the secret message. This

allows us to define a target which does not depend on the secret message rate, and to study the achievable equivocation rate. Then, some nested coding approach [24] should be used to achieve a secret message rate that approaches the achievable equivocation rate. Nested codes can also be obtained through the scrambling-based non-systematic encoding approach proposed in [15]–[17], by using a code with length N and dimension $N_d = R_c N$, and $N_s \leq N_d$ bits for the secret message. The $N_d - N_s$ remaining information bits are randomly generated, therefore each secret message is randomly associated to $2^{N_d - N_s}$ codewords. This, however, is out of the scope of this paper.

In the following, we derive bounds on the ε -outage security gaps for CPS and CAS, and discuss the optimization of the corresponding power allocations.

C. Computation of $\bar{\gamma}_{\max}^E$ and γ_δ^B

The parameters required for the computation of the security gap (33) are now derived.

Computation of $\bar{\gamma}_{\max}^E$ for CPS: When coding is applied separately on each sub-message, condition (25b) must hold on each channel.

The eavesdropper outage probability becomes

$$\begin{aligned} p^E &= 1 - \prod_{k=1}^K (1 - \mathbb{P}[p_k^E < 1 - \eta]) \\ &= 1 - \prod_{k=1}^K (1 - \mathbb{P}[P_k G_k > \gamma_\eta^E(k)]), \end{aligned} \quad (34)$$

where p_k^E is Eve's CER on the k -th channel, and $\gamma_\eta^E(k)$ is the maximum SNR on the same channel which ensures $p_k^E \geq 1 - \eta$, that is

$$\gamma_\eta^E(k) = \max \{ \gamma : \mathbb{P}[E_k^E | P_k G_k = \gamma] \geq 1 - \eta \}$$

with E_k^E denoting Eve's decoding error event on channel k . In Appendix D we derive a lower bound on the value of $\gamma_\eta^E(k)$ which permits us to estimate the best performance achievable by Eve. From the Rayleigh distribution assumption we have

$$\mathbb{P}[P_k G_k > \gamma_\eta^E(k)] = \exp\left(-\frac{\gamma_\eta^E(k)}{P_k \alpha_E}\right) \quad (35)$$

and hence (34) becomes

$$p^E = 1 - \prod_{k=1}^K \left[1 - \exp\left(-\frac{\gamma_\eta^E(k)}{P_k \alpha_E}\right) \right]. \quad (36)$$

By exploiting these expressions, and the knowledge of the transmission (and reception) technique, we can compute $\bar{\gamma}_{\max}^E$ for which condition (25b) is satisfied for a given power allocation.

Computation of $\bar{\gamma}_{\max}^E$ for CAS: When CAS is implemented, no closed form expression exists for Eve's CER; hence we resort to a lower bound. In particular, since the CER is a non-increasing function of the SNR on each channel, we have

$$\begin{aligned} \mathbb{P} [E^E | P_1 G_1 = \gamma_1, \dots, P_K G_K = \gamma_K] &\geq \\ \mathbb{P} [E^E | P_1 G_1 = \gamma_M, \dots, P_K G_K = \gamma_M] & \end{aligned} \quad (37)$$

where $M = \arg \max_k \gamma_k$ is the index of the channel with maximum SNR. Hence, a sufficient condition for (25b) is that $\max_k P_k G_k \leq \min_k \gamma_\eta^E(k)$, thus we have

$$\mathbb{P} [p^E < 1 - \eta] \leq \mathbb{P} \left[\max_k \{P_k G_k\} > \min_k \gamma_\eta^E(k) \right] \quad (38)$$

and we can replace (32) with

$$\begin{aligned} \bar{\gamma}_{\max}^E &= \frac{1}{K} \sum_k P_k \max \{ \alpha_E : \\ &\mathbb{P} \left[\max_k \{P_k G_k\} > \min_k \gamma_\eta^E(k) \right] \leq \varepsilon \}. \end{aligned} \quad (39)$$

The probability on the r.h.s. of (38) can be calculated as

$$\begin{aligned} \mathbb{P} \left[\max_k \{P_k G_k\} > \min_k \gamma_\eta^E(k) \right] &= \\ \mathbb{P} \left[\bigcup_{k=1}^K \{P_k G_k > \min_k \gamma_\eta^E(k)\} \right] &= \\ 1 - \prod_{k=1}^K \left[1 - \exp \left(-\frac{\min_k \gamma_\eta^E(k)}{P_k \alpha_E} \right) \right] &. \end{aligned} \quad (40)$$

Therefore, we obtain an expression similar to (36), though in this case it results from the use of the lower bound (37), while in the CPS case it is given by an exact derivation. For the special case in which $\gamma_\eta^E(1) = \gamma_\eta^E(2) = \dots = \gamma_\eta^E(K) = \gamma_\eta^E$, these two expressions coincide; so, we can use the same formula to model both the CPS and CAS scenarios.

Computation of γ_δ^B : In order to model Bob's channels, which are supposed to be known, we only need to compute γ_δ^B , that is, the threshold value of the channel gains which allows constraints (28) to be satisfied.

In this part of the analysis, we refer to ML decoding also for Bob, and use the well-known union bound to obtain an upper bound on p^B . In fact, in the high SNR region, the union bound is known to provide a tight approximation of the performance of ML and ML-like decoders [25].

Let us consider a linear block code with codeword length N , and let d_{\min} denote the code minimum distance and A_w the number of codewords with weight w . If we focus on a single channel with SNR γ , we have the following bound on the CER

$$p^B \leq \sum_{w=d_{\min}}^N A_w Q\left(\sqrt{2\gamma w}\right), \quad (41)$$

where $Q(x) = \frac{1}{\sqrt{2\pi}} \int_x^{\infty} e^{-t^2/2} dt$ is the complementary CDF of the zero-mean, unit-variance Gaussian distribution. By considering only the minimum weight codewords, we get the following approximation

$$p^B \simeq A_{d_{\min}} Q\left(\sqrt{2\gamma d_{\min}}\right), \quad (42)$$

that provides a very good estimate of ML (or ML-like) decoding performance for large values of γ , i.e., small values of CER, that are those of interest for Bob. By using the parameters of the code used in the k -th channel, and by equating the r.h.s. of (42) to δ and solving for γ , we obtain $\gamma_{\delta}^B(k)$ under ML decoding, as defined in (29). Concerning the CAS scenario, according to (30), we have $\gamma_{\delta}^B = \max_k \gamma_{\delta}^B(k)$.

D. Power Allocation

Let us consider fixed secrecy rate transmissions, regardless of the channel state. On the other hand, by varying the power allocation we can alter the decoding reliability at Bob and Eve. Hence, in a parallel to the security rate regions, we see that conditions (25) define regions for power allocation strategies that ensure reliable and secure communications.

In order to satisfy Bob's reliability condition (28), Alice transmits at minimum power levels

$$P_k = \frac{\gamma_{\delta}^B(k)}{H_k}. \quad (43)$$

More precisely, based on (43), Alice finds the optimal power allocation, and checks whether the power constraint (2b) is satisfied or not. In the former case, transmission occurs. Otherwise, Alice skips the transmission, since the reliability target cannot be achieved.

V. NUMERICAL RESULTS

On the basis of the theoretical analysis developed in the previous sections, we provide here some examples, under different conditions of the parallel channels. Since the target of our

analysis is not to find an optimal code/allocation strategy for the CPS and CAS schemes, but rather to assess and compare the performance achievable by using a practical code in these configurations, we fix the choice of the code for both CPS and CAS. Moreover, for CPS, full variable rate coding on each channel could be considered. In this section, however, aiming at practically feasible and simple systems, we use a linear block code with fixed length and rate for all channels. As a counterpart, this means that CPS performance could be further improved by a proper encoder selection over channels with different bit-loading. Under this assumption, we have $\gamma_\delta^B(1) = \gamma_\delta^B(2) = \dots = \gamma_\delta^B(K) = \gamma_\delta^B$ and $\gamma_\eta^E(1) = \gamma_\eta^E(2) = \dots = \gamma_\eta^E(K) = \gamma_\eta^E$.

For both CPS and CAS, we suppose to use binary phase shift keying (BPSK) and a linear block code with length $N = 128$ bits and rate $R_c = 1/2$. We focus on a $(128, 64)$ extended BCH (eBCH) code with minimum distance $d_{\min} = 22$. It must be noted that, contrary to the approaches searching for secrecy capacity achieving codes [9], [10], in our analysis the code parameters (rate and length) are fixed.

The eBCH code, in particular, is good for the chosen length, since soft-decision algorithms can be used for decoding, achieving performance close to that of state-of-the-art LDPC codes. In these conditions, it is realistic to assume that Bob and Eve use the same decoder, and this contributes to keeping the security gap small. On the other hand, ML-like decoding becomes intractable for longer codes, while long LDPC codes with soft-decision iterative decoding achieve good performance with limited complexity. The choice of LDPC codes allows Bob to work at a lower SNR, but the gap to the theoretical limits increases. Hence, since we assume that Eve is always able to use the best decoder, the security gap by using long LDPC codes becomes larger than for the case of short eBCH codes with ML-like decoding. On the other hand, if we relax this hypothesis, and consider that Eve uses a practical decoder, the resulting security gap becomes smaller. For example, by using long LDPC codes and iterative belief propagation decoding for both Bob and Eve, a security gap reduction of several dBs would result with respect to the case of short eBCH codes with ML-like decoding.

A. Coding per Sub-message

1) *Security gap and equivocation rate with eBCH coding:* The achievable performance for $N = 128$ and rate $R_c = 1/2$ is shown in Fig. 3, in terms of CER over a single static channel with AWGN, as a function of the channel SNR γ . The union bound, computed through (41),

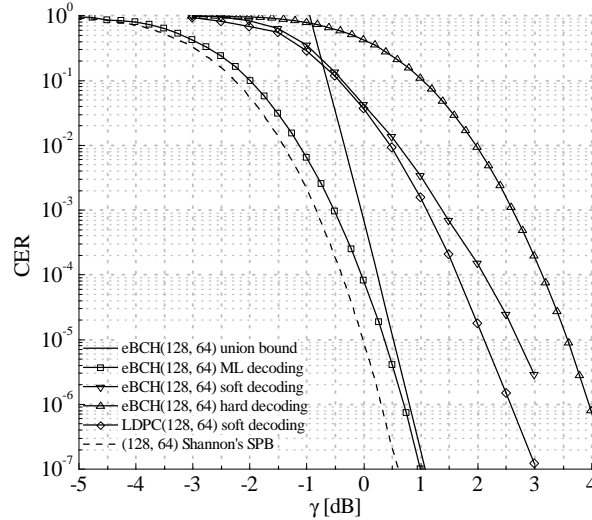

Fig. 3. CER simulated values and bounds for codes with length $N = 128$ and rate $R_c = 1/2$ over a single static channel with SNR γ .

and the Shannon's sphere packing bound (SPB), computed as described in Appendix D, are also shown for the sake of comparison. The performance of the eBCH code under ML decoding is obtained as in [26]. From the figure we observe that the ML decoding performance is tightly upper bounded by the union bound in the high SNR region, and tightly lower bounded by Shannon's SPB in the low SNR region. This confirms that the two bounds are well suited to model the performance achievable on each channel by Bob and Eve, respectively. We also report, for the sake of comparison, the performance achieved by using other decoders. Soft-decision decoding of the eBCH code has been implemented by following the approach proposed in [27], while hard-decision decoding of the same code has been simply estimated by using the closed form expression for bounded distance decoders [28]. We have also included the performance of an LDPC code, with the same length and rate, designed through the progressive edge growth algorithm [29], and decoded through the logarithmic version of the sum-product algorithm [30]. Shannon's SPB provides a lower bound for all the considered schemes, so it actually represents a reliable and conservative tool for modeling Eve's performance. Instead, when Bob uses other decoders than ML, his performance can be far worse than the union bound. In this case, the security gap must be increased by a suitable margin, which depends on the specific decoding algorithm used by Bob. By focusing on ML decoding for both Bob and Eve, and using the upper

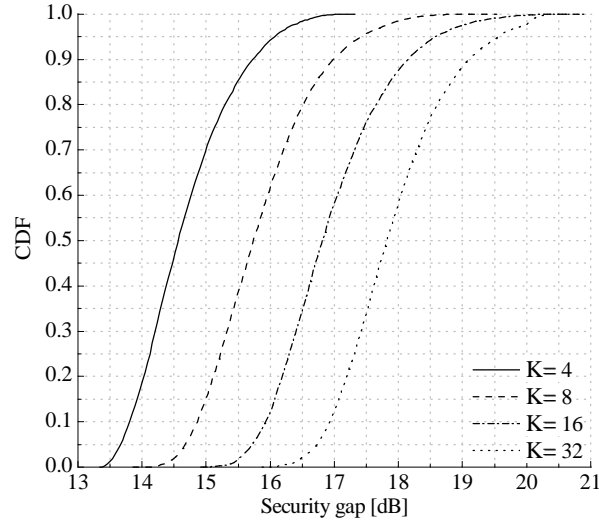

Fig. 4. Distribution of the security gap with $K = 4, 8, 16, 32$ parallel channels. Bob's channels are known and Alice adopts optimal power allocation.

TABLE I

SECURITY GAP S_ε FOR A (128, 64) EBCH CODED TRANSMISSION WITH CPS OVER K PARALLEL CHANNELS, WITH OUTAGE PROBABILITY $\varepsilon = 10^{-2}$. CASE OF EQUAL BOB'S CHANNEL GAINS.

K	1	2	4	8	16	32	64	128
$\bar{\gamma}_{\max}^E$	-11.43 dB	-12.04 dB	-12.57 dB	-13.05 dB	-13.48 dB	-13.87 dB	-14.22 dB	-14.56 dB
S_ε	12.23 dB	12.84 dB	13.37 dB	13.85 dB	14.28 dB	14.67 dB	15.02 dB	15.36 dB

and lower bounds, we can estimate γ_δ^B and γ_η^E . For example, if $\delta = 10^{-6}$ and $\eta = 0.1$, we have $\gamma_\delta^B = 0.8$ dB and $\gamma_\eta^E = -4.8$ dB.

If we consider that Bob's channels are known, we can use the approach in Section IV-D and assume that Alice chooses the optimal power allocation strategy as given by (43), checking that the power constraint (2b) is verified. Considering CPS, using (36) and imposing $\varepsilon = 10^{-2}$, we find the maximum value of α_E , as defined in Section II, from which $\bar{\gamma}_{\max}^E$ is obtained, according to (32). We have simulated 10000 realizations of Bob's channels, with $K = 4, 8, 16, 32$, and a maximum average power transmitted by Alice equal to $P_{\max} = \gamma_\delta^B / \alpha_B$. The resulting CDF of the security gap is shown in Fig. 4. The average security gap, in these four cases, is 14.68 dB, 15.84 dB, 16.94 dB and 17.93 dB for $K = 4, 8, 16$ and 32, respectively.

For the sake of comparison, we can consider an ideal scenario, in which all Bob's channel

gains are equal and coincide with their mean, $H_k = \alpha_B, k = 1, \dots, K$. In this case, we have $P_k = P_{\max}, \forall k$. This benchmark scenario is considered in Table I, where we report the values of $\bar{\gamma}_{\max}^E$ and S_ε for different values of K . We observe that, in this case, the security gap is lower than the average security gap for the case with Rayleigh distributed Bob's channels, which has been reported, for $K = 4, 8, 16$ and 32 , at the end of the previous paragraph.

We compute the equivocation rate by following the derivation reported in Section IV-A. For the sake of simplicity, we consider again the case $H_k = \alpha_B, k = 1, \dots, K$, yielding that uniform power allocation is the optimal solution and we have $P_k H_k = \gamma^B, P_k \alpha_E = \bar{\gamma}^E = \gamma^B / S_\varepsilon$. We also suppose that the minimum transmission power (43) is used to achieve the reliability target (28). Under these hypotheses, the constellation constrained secrecy rate becomes

$$C_s^{(\varepsilon)} = C(\gamma_\delta^B) - C\left(-\bar{\gamma}^E \frac{\ln \varepsilon}{K}\right), \quad (44)$$

while the equivocation rate considering a code with rate R_c is

$$R_e^{(\varepsilon)} = R_c - C\left(-\bar{\gamma}^E \ln(1 - (1 - \varepsilon)^{1/K})\right), \quad (45)$$

where $C(\gamma)$ is given by

$$C(\gamma) = 1 - \frac{1}{\sqrt{2\pi}} \int_{-\infty}^{+\infty} e^{-\frac{(y - \sqrt{\gamma})^2}{2}} \log(1 + e^{-2y\sqrt{\gamma}}) dy. \quad (46)$$

By using these expressions, we have computed $R_e^{(\varepsilon)}$ and $C_s^{(\varepsilon)}$, as functions of $\bar{\gamma}^E$, for $\gamma^B = \gamma_\delta^B = 0.8$ dB, $\varepsilon = 0.01$, $R_c = 1/2$ and some values of K . Results are reported in Fig. 5. As expected, we observe that, for decreasing values of $\bar{\gamma}^E$, the ε -outage equivocation rate approaches the BPSK-constrained secrecy rate, and the dependence on K vanishes.

2) *Secrecy rate with $K = 2$ parallel channels:* In this example, we consider a simple case in which the secret message is transmitted over two channels only (i.e., $K = 2$) and the secrecy outage probability is constrained below the threshold $\varepsilon = 0.01$.

We report the secrecy rates that are obtained by the optimal solution as described in (14) as well as the secrecy rates achieved by two suboptimal methods. These are obtained by fixing the power allocation, in one case to an equal power distribution between the two channels, in the other by waterfilling on the legitimate receiver channels. The secrecy rates are then optimized under the given power allocation and the constraint on the secrecy outage probability.

Fig. 6 shows the contour lines of the secrecy rates obtained with the different power allocations described above, as a function of the power gains of Bob's channels. The eavesdropper average

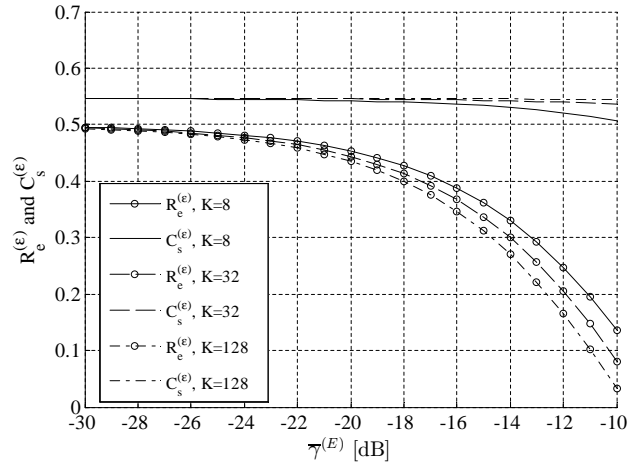

Fig. 5. ε -outage equivocation rate $R_e^{(\varepsilon)}$ and BPSK-constrained secrecy rate $C_s^{(\varepsilon)}$ for $\gamma^B = \gamma_\delta^B = 0.8$ dB, $R_c = 1/2$ and $\varepsilon = 0.01$.

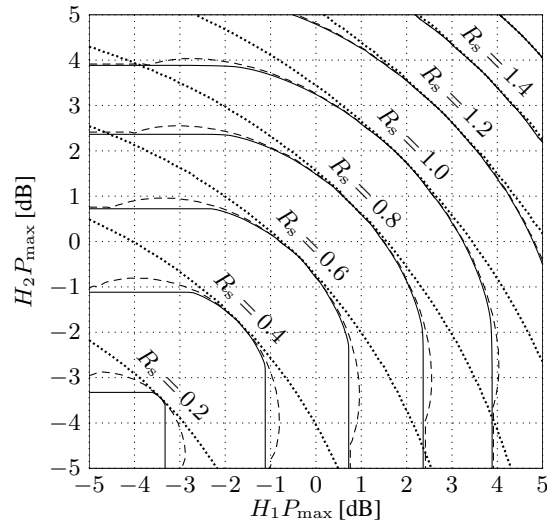

Fig. 6. Contour plot of the achievable secrecy rates with with CPS under optimal (solid), waterfilling (dashed), and equal (dotted) power allocation, for different values of Bob's channel gains. In all plots, $\varepsilon = 0.01$, and $\alpha_E P_{\max} = 0.05$.

power gain is such that $\alpha_E P_{\max} = 0.05$ for each channel. As expected from the symmetry of the problem, the three strategies provide similar performance when H_1 and H_2 are close to each other, as all three methods equally divide the power between the two channels. On the other hand, when H_1 and H_2 are very different, the optimal solution is to load all power on the

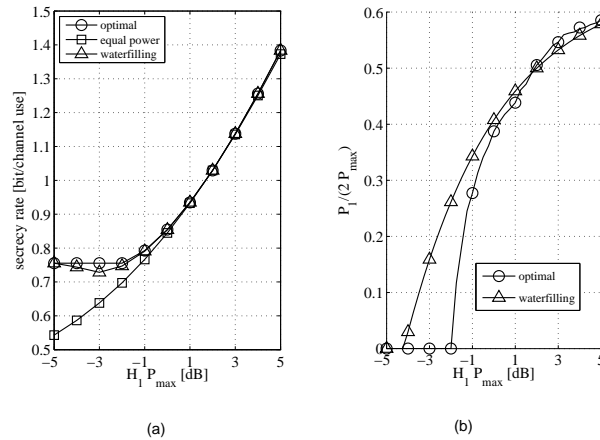

Fig. 7. (a) Achievable secrecy rates with CPS and (b) fraction $P_1/(2P_{\max})$ of the available power that is allocated to $k = 1$. In all plots, $\varepsilon = 0.01$, $\alpha_E P_{\max} = 0.05$ and $H_2 P_{\max} = 2$ dB.

stronger channel while waterfilling is suboptimal, and equal power allocation achieves a much lower rate. Waterfilling loses against the optimal solution in the intermediate region, as it is possible to observe from Fig. 7(a), in which the secrecy rates are shown for a specific value of Bob's gain in the second channel, i.e., $H_2 P_{\max} = 2$ dB. The loss can also be seen (although it is not shown here) to be increasing with the values of α_E , since as α_E decreases the constraint on secrecy becomes less stringent than that on reliability, and waterfilling becomes more effective. This effect is explained by observing that waterfilling allocates power to a channel when its gain is above a certain threshold to guarantee a benefit in terms of transmission rate without secrecy constraints. However, when a constraint is imposed on the secrecy outage probability, this threshold increases. This is also observed in Fig. 7(b), in which the fraction of power allocated to the first channel by the two non-uniform methods is reported. We see that, when H_1 is small, the optimal power allocation provides the first channel with a lower fraction of power compared to waterfilling. In particular, in order to allocate power to the first channel, the optimal joint rate/power allocation method requires a significantly higher average received power than that required by the waterfilling solution.

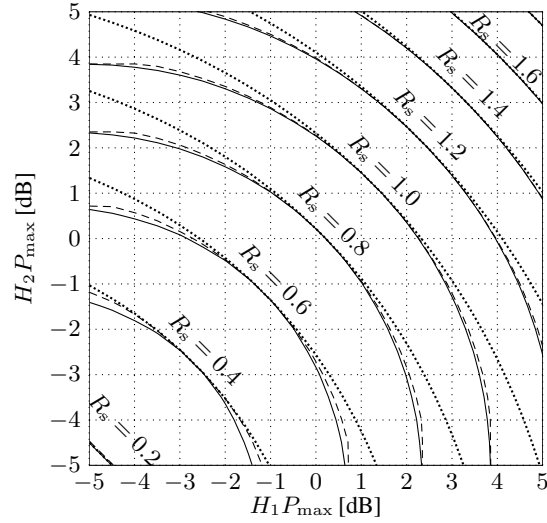

Fig. 8. Contour plot of the achievable secrecy rates with with CAS under optimal (solid), waterfilling (dashed), and equal (dotted) power allocation, for different values of Bob's channel gains. In all plots, $\varepsilon = 0.01$, and $\alpha_E P_{\max} = 0.05$.

B. Coding Across Sub-messages

1) *Security gap with eBCH coding:* Let us consider the case of $K = 128$ parallel channels and the same code used in Section V-A, having $N = 128$ and rate $R_c = 1/2$. The value of $\bar{\gamma}_{\max}^E$ can be estimated through (39), which provides the same result already computed for this code with CPS over $K = 128$ parallel channels, due to the use of the lower bound (37). Therefore, by considering $\varepsilon = 10^{-2}$, we obtain $S_\varepsilon = 15.36$ dB, as reported in Table I.

When Bob's channel is also known only in statistical terms, we can use the approach described in Appendix C to estimate the security gap. This way, and by using the upper bound (62) for estimating $\bar{\gamma}_{\min}^B$, we obtain that the system requires a security gap equal to 56.41 dB, which is the same as with CPS and $K = 128$. Nevertheless, we can avoid to use the bound (62) by exploiting, for the case of CAS, the per-realization method described in [31]. This way, as detailed in Appendix C, we obtain a security gap equal to 18.21 dB, which highlights the superiority of CAS over CPS in these conditions.

2) *Secrecy rate with $K = 2$ parallel channels:* In this example, we assess the secrecy rate of the CAS scheme and compare it with the corresponding secrecy rate achieved by CPS for the simple case of $K = 2$ parallel channels. Fig. 8 shows the contour lines of the secrecy rate

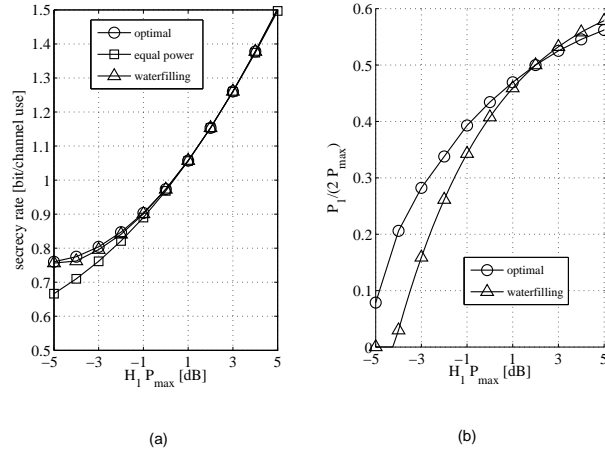

Fig. 9. (a) Achievable secrecy rates with CAS and (b) fraction $P_1/(2P_{\max})$ of the available power that is allocated to $k = 1$. In all plots, $\varepsilon = 0.01$, $\alpha_E P_{\max} = 0.05$ and $H_2 P_{\max} = 2$ dB.

(19) obtained within the same two-channel scenario and for the three power allocation strategies considered in Section V-A. Due to its increased flexibility, we expect that CAS outperforms CPS when achievable rates are considered. Indeed, this is confirmed by comparing Fig. 8 with Fig. 6. Still, note that their performances in the considered simulation scenario are quite close, so that other implementation issues may guide the choice between the two schemes. For example, CAS is more robust against imperfect power allocation, as we note that the loss incurred by equal power allocation and waterfilling with respect to the optimal solution is almost negligible for a wide range of channel gains (as can be also observed in Fig. 8). However, other issues may be relevant for a complete comparison, as those mentioned at the end of Section II. On the other hand, Fig. 9(b) shows that, opposite to CPS, when H_1 is small, the optimal power allocation for CAS provides the first channel with a higher fraction of power compared to waterfilling.

3) *Channel selection and uniform power allocation:* As a more practical example of the use of CAS, we have also considered the case of $K = 48$ channels. Since the computation of the optimal power allocation in this case is infeasible, we have considered a suboptimal approach, in which only a subset of $K' \leq K$ channels (those with the highest H_k) are used and the available power is allocated uniformly among them. By imposing an outage probability $\varepsilon = 0.01$, and considering $P_{\max} = 3.8$ dB and $\alpha_B = 1$, Fig. 10(a) shows the maximum (over all values of $K' \leq K$) mean outage secrecy rate $R_s = \frac{1}{K} \sum_k R_k$ as a function of α_E . As expected, from the

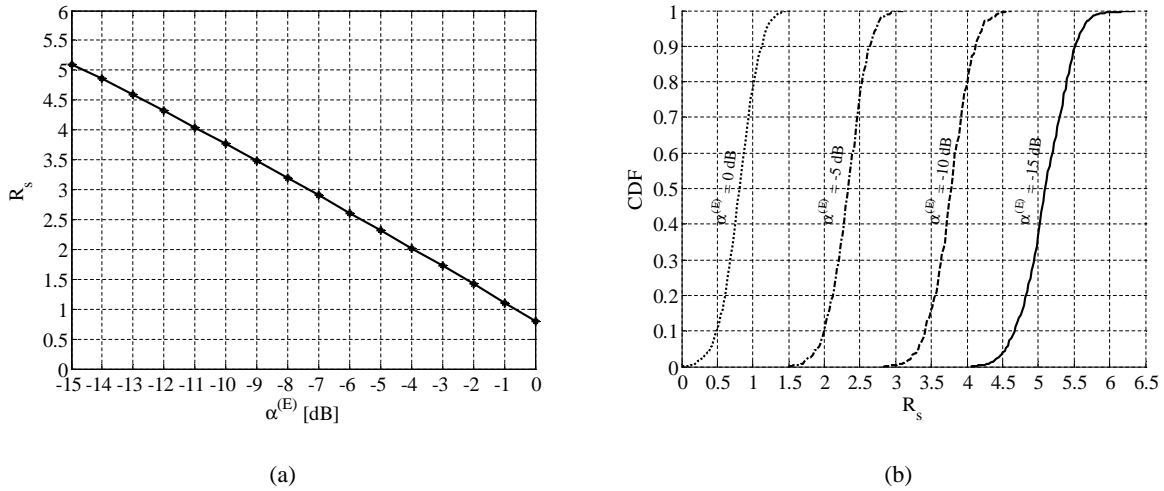

Fig. 10. Outage secrecy rates with selection of $K' \leq K = 48$ sub-messages and uniform power allocation among them: (a) mean ε -outage secrecy rate and (b) CDF of secrecy rates due to the statistics of Bob's channel gains around α_B .

figure we observe that, as α_E increases, the mean outage secrecy rate decreases. This behavior is confirmed by Fig. 10(b), that shows CDFs of the outage secrecy rates due to the statistics of Bob's channel, for different values of α_E .

VI. CONCLUSIONS

In this paper we have characterized the performance of secret transmissions over parallel channels, under the assumption of knowing the Alice-Bob channel and having only a statistical description of the Alice-Eve channel. We have used a set of metrics that allow studying the problem both from the theoretical standpoint and by considering practical coded transmission schemes. We have derived bounds on the achievable outage secrecy rates (using ideal codes), and studied the effect of power allocation on the secrecy performance. The definitions of security gap and equivocation rate have been extended to this scenario, and we have used them to assess the requirements for achieving security when practical codes are adopted.

APPENDIX A

PROOF OF THEOREM 1

From (11) we have

$$\frac{1 + H_k P_k}{P_k 2^{R_k}} - \frac{1}{P_k} = -\alpha_E \ln \bar{p}_k \quad (47)$$

which can be rewritten as

$$2^{R_k} = \frac{1 + H_k P_k}{\bar{u}_k P_k + 1}. \quad (48)$$

From (48) we immediately obtain the second result of the theorem.

By the Karush-Kuhn-Tucker (KKT) conditions, problem (3) subject to power constraint (2b) can be written as

$$\max_{\mathbf{P}, \nu} \sum_{k=1}^K \left[\log \frac{1 + H_k P_k}{\bar{u}_k P_k + 1} - \nu (P_k - P_{\max}) \right]. \quad (49)$$

Setting to zero the derivative with respect to P_k we obtain

$$\frac{\bar{u}_k P_k + 1}{1 + H_k P_k} \left[\frac{H_k}{\bar{u}_k P_k + 1} - \frac{\bar{u}_k (1 + H_k P_k)}{(\bar{u}_k P_k + 1)^2} \right] - \nu = 0 \quad (50)$$

which can be rewritten as

$$\bar{u}_k \nu H_k P_k^2 + \nu (\bar{u}_k + H_k) P_k + \nu - H_k + \bar{u}_k = 0. \quad (51)$$

Now, from (51), if $\nu - H_k + \bar{u}_k < 0$ we obtain (12).

APPENDIX B

PROOF OF (17)

From (4) and (15) we can rewrite $p_s(\mathbf{P}, R; \mathbf{H})$ as

$$p_s(\mathbf{P}, R; \mathbf{H}) = \mathbb{P} \left[\prod_{k=1}^K (1 + G_k P_k) \geq \Phi(\mathbf{P}, R; \mathbf{H}) \right]. \quad (52)$$

Defining $\beta = \prod_{k=1}^K (1 + G_k P_k)$ we have

$$p_s(\mathbf{P}, R; \mathbf{H}) = 1 - \int_1^{\Phi(\mathbf{P}, R; \mathbf{H})} p_\beta(a) da \quad (53)$$

with $p_\beta(a)$ the PDF of β , which has been computed in [32]. We recall the definition of the generalized Fox H-function [32]

$$\begin{aligned} \mathcal{H}_{p,q}^{m,n} \left[r \left| \begin{array}{c} \{a_i, c_i, A_i\} \\ \{b_j, d_j, B_j\} \end{array} \right. \right] = \\ \frac{1}{2\pi i} \oint_{\mathcal{C}} M_{p,q}^{m,n} \left[s \left| \begin{array}{c} \{a_i, c_i, A_i\} \\ \{b_j, d_j, B_j\} \end{array} \right. \right] r^{-s} ds, \end{aligned} \quad (54)$$

where \mathcal{C} is a contour in the complex plane from $\omega - i\infty$ to $\omega + i\infty$ (where i is the imaginary unit) such that $(b_i + k)/d_i$ and $(a_i - 1 - k)/c_i$ (with k non-negative integer) lie to the right and left of \mathcal{C} , respectively, and

$$M_{p,q}^{m,n} \left[s \left| \begin{array}{c} \{a_i, c_i, A_i\} \\ \{b_j, d_j, B_j\} \end{array} \right. \right] = \frac{\prod_{j=1}^m \hat{\Gamma}(b_j + d_j s, B_j) \prod_{i=1}^n \hat{\Gamma}(1 - a_i - c_i s, A_i)}{\prod_{i=n+1}^p \hat{\Gamma}(a_i + c_i s, A_i) \prod_{j=m+1}^q \hat{\Gamma}(1 - b_j - d_j s, B_j)} \quad (55)$$

is the Mellin transform of the generalized Fox H-function, where $\hat{\Gamma}(\cdot, \cdot)$ is the upper incomplete Gamma function

$$\hat{\Gamma}(s, a) = \int_a^\infty t^{s-1} e^{-t} dt, \quad (56)$$

and an empty product is taken to be one. We have [32]

$$p_\beta(a) = \frac{\varepsilon(\mathbf{P})}{\varphi(\mathbf{P})} \mathcal{H}_{0,K}^{K,0} \left[\frac{a}{\varphi(\mathbf{P})} \left| \begin{array}{c} \{-, -, -\} \\ \{0, 1, (P_k \alpha_E)^{-1}\}_{k=1, \dots, K} \end{array} \right. \right],$$

for $a \geq 1$ and $p_\beta(a) = 0$ otherwise. The notation $\{-, -, -\}$ means that the coefficients are absent. Now, by observing that

$$\int_1^q t^{-s} dt = \frac{q^{1-s} - 1}{1-s} = (q^{1-s} - 1) \frac{\hat{\Gamma}(1-s, 0)}{\hat{\Gamma}(2-s, 0)} \quad (57)$$

and inserting the integral of (53) into (54) and using (57) together with (55) we obtain (17).

APPENDIX C

SECURITY GAP FOR BOB'S CHANNEL KNOWN ONLY IN STATISTICAL TERMS

When Bob's channels are known only in statistical terms, we consider an outage approach also for Bob in order to define the security gap. In fact, p^B is a random variable, whose distribution is uniquely determined by the average SNR. The average SNR of the Alice-Bob channel is

$$\bar{\gamma}^B = \frac{1}{K} \sum_k \alpha_B P_k, \quad (58)$$

under the assumption of i.i.d. Rayleigh channels.

We are interested in finding the minimum value of $\bar{\gamma}^B$, denoted as $\bar{\gamma}_{\min}^B$, for which the probability that (28) does not hold is not greater than ω , i.e., for CPS

$$\bar{\gamma}_{\min}^B = \frac{1}{K} \sum_k P_k \min\{\alpha_B : \mathbb{P}[\cup_{k=1}^K \{p_k^B > \delta\}] \leq \omega\} \quad (59a)$$

and for CAS

$$\bar{\gamma}_{\min}^B = \frac{1}{K} \sum_k P_k \min\{\alpha_B : \mathbb{P}[p^B > \delta] \leq \omega\}, \quad (59b)$$

where p_k^B is Bob's CER on each channel. Then the (ω, ε) security gap in this case is defined as

$$S_{\omega, \varepsilon} = \frac{\bar{\gamma}_{\min}^B}{\bar{\gamma}_{\max}^E}, \quad (60)$$

where $\bar{\gamma}_{\max}^E$ is given by (32). The value of $\bar{\gamma}_{\min}^B$ is computed next for CPS and CAS.

Computation of $\bar{\gamma}_{\min}^B$ for CPS: When CPS is considered, we must impose that $p_k^B \leq \delta$. Therefore, Bob's outage probability is

$$\begin{aligned} \mathbb{P}[\cup_{k=1}^K \{p_k^B > \delta\}] &= 1 - \prod_{k=1}^K (1 - \mathbb{P}[p_k^B > \delta]) = \\ &= 1 - \prod_{k=1}^K (1 - \mathbb{P}[P_k H_k < \gamma_\delta^B(k)]). \end{aligned} \quad (61)$$

From the Rayleigh distribution assumption, we have $\mathbb{P}[P_k H_k < \gamma_\delta^B(k)] = 1 - \exp\left(-\frac{\gamma_\delta^B(k)}{P_k \alpha_B}\right)$, and by equating the r.h.s. of (61) to ω , we can derive the value of α_B and the corresponding $\bar{\gamma}_{\min}^B$.

By using the same assumptions as in Section V, i.e., by considering the use of BPSK and of the same eBCH code with length $N = 128$ and rate $R_c = 1/2$ on all channels, we have computed $\bar{\gamma}_{\min}^B$ for the case of CPS. The results, and the corresponding values of $S_{\omega, \varepsilon}$ obtained by using the values of $\bar{\gamma}_{\max}^E$ given in Table I, are reported in Table II. As expected, when Bob's channels are known only in statistical terms, the values of the security gap needed to ensure conditions (25) are significantly higher than those for the case in which Bob's channels are known exactly, which have been reported in Table I.

TABLE II

SECURITY GAP $S_{\omega, \varepsilon}$ FOR A (128, 64) EBCH CODED TRANSMISSION WITH CPS OVER K PARALLEL CHANNELS, WITH OUTAGE PROBABILITIES $\omega = \varepsilon = 10^{-2}$.

K	1	2	4	8	16	32	64	128
$\bar{\gamma}_{\min}^B$	20.78 dB	23.79dB	26.80 dB	29.81 dB	32.82 dB	35.83 dB	38.84 dB	41.85 dB
$S_{\omega, \varepsilon}$	32.21 dB	35.83 dB	39.37 dB	42.86 dB	46.30 dB	49.70 dB	53.06 dB	56.41 dB

Computation of $\bar{\gamma}_{\min}^B$ for CAS: Similarly to what has been done for Eve in Section IV-C, for CAS we are interested in finding a worst-case estimate of Bob's error probability. As a closed form expression is not available, we resort to an upper bound. In particular we have

$$\begin{aligned} \mathbb{P} [E^B | P_1 H_1 = \gamma_1, \dots, P_K H_K = \gamma_K] &\leq \\ \mathbb{P} [E^B | P_1 H_1 = \gamma_m, \dots, P_K H_K = \gamma_m] & \end{aligned} \quad (62)$$

where $m = \arg \min_k \gamma_k$ is the index of the channel with the minimum SNR. Hence, a sufficient condition for (28) is that $\min_k P_k H_k \geq \max_k \gamma_\delta^B(k)$, and we can replace (59) with $\bar{\gamma}_{\min}^B = \frac{1}{K} \sum_k P_k \min\{\alpha_B : \mathbb{P} [\min_k \{P_k H_k\} < \max_k \gamma_\delta^B(k)] \leq \omega\}$. Moreover, we have

$$\begin{aligned} \mathbb{P} \left[\min_k \{P_k H_k\} < \max_k \gamma_\delta^B(k) \right] &= \\ \mathbb{P} \left[\bigcup_{k=1}^K P_k H_k < \max_k \gamma_\delta^B(k) \right] &= \\ 1 - \prod_{k=1}^K (1 - \mathbb{P} [P_k H_k < \max_k \gamma_\delta^B(k)]) & \end{aligned} \quad (63)$$

So, in the special case in which $\gamma_\delta^B(1) = \gamma_\delta^B(2) = \dots = \gamma_\delta^B(K) = \gamma_\delta^B$, we obtain again the same expression for both CPS and CAS scenarios. However, for CPS it provides exact results, while for CAS it is due to the use of the upper bound (62).

Let us consider an example with $K = 128$ parallel channels, over which the same (128, 64) eBCH code considered in Section V is used to implement CAS. In this case, we have $\bar{\gamma}_{\max}^E = -14.56$ dB, $\bar{\gamma}_{\min}^B = 41.85$ dB and $S_{\omega, \varepsilon} = 56.41$ dB, as it results from Tables I and II.

In order to avoid resorting to the upper bound (62) for estimating $\bar{\gamma}_{\min}^B$, we can use the per-realization method described in [31]. This method provides an estimate of the CER achieved by a given code when each coded bit is transmitted over a channel with a different gain, and the channel gains are Rayleigh distributed. This situation exactly models the CAS scenario we consider, and the estimate so found is tight for ML-like decoders and high SNR values, that matches with Bob's condition. Therefore, we have applied this method by computing all the 243840 codewords with weight 22 in the (128, 64) eBCH code, according to [33]. The results obtained are reported in Fig. 11 in terms of the estimated CER as a function of $\bar{\gamma}^B$, for several values of Bob's outage probability ω . Based on these results, we get that $p^B \leq 10^{-6}$ for $\bar{\gamma}^B \geq \bar{\gamma}_{\min}^B = 3.65$ dB and $\omega = 10^{-2}$. Therefore, a tighter estimate of the security gap in this case is $S_{\omega, \varepsilon} = 18.21$ dB.

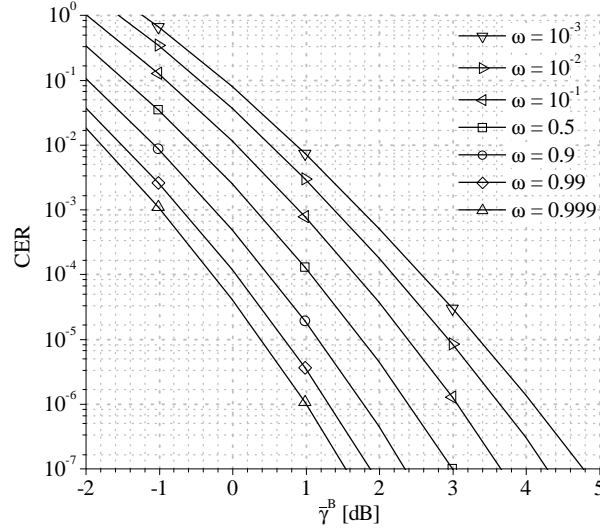

Fig. 11. Upper bound on the CER estimated through the per-realization analysis for the eBCH code with length $N = 128$, rate $R_c = 1/2$ and several values of Bob's outage ω .

APPENDIX D

ON THE COMPUTATION OF γ_η^E

We assume that Eve uses ML decoding, which represents the most dangerous condition for the legitimate receiver. In order to assess Eve's error rate, we use Shannon's SPB on the error probability of a coded transmission with ML decoding [34], which is the tightest one for high error rate values, at which Eve is supposed to operate.

By Shannon's SPB on the block error probability under ML decoding, the error probability at Eve's over a single channel with SNR γ is bounded by [35]

$$p^E(\gamma) > P_{\text{SPB}}(N, \vartheta, A), \quad (64)$$

where $P_{\text{SPB}}(N, \vartheta, A)$ is the probability that the received vector falls outside the N -dimensional circular cone of half angle ϑ whose main axis passes through both the origin and the point corresponding to the transmitted signal [35]. In (64), $A = \sqrt{2R_c\gamma}$, where R_c is the code rate.

The tightest lower bound on the error probability is achieved for $\vartheta_1(N, R_{cn})$ such that

$$\frac{\Omega_N(\vartheta_1(N, R_{cn}))}{\Omega_N(\pi)} = \exp(-NR_{cn}), \quad (65)$$

where R_{cn} is the code rate in nats per channel use, $\Omega_N(\vartheta) = \frac{2\pi^{(N-1)/2}}{\Gamma((N-1)/2)} \int_0^\vartheta (\sin \varphi)^{N-2} d\varphi$,

$\Omega_N(\pi) = \frac{2\pi^{N/2}}{\Gamma(N/2)}$, and $\Gamma(\cdot)$ denotes the Gamma function. From [35] we have

$$P_{\text{SPB}}(N, \vartheta, A) = \frac{(N-1) \exp\left(-\frac{NA^2}{2}\right)}{\sqrt{2\pi}} \times \int_{\vartheta}^{\frac{\pi}{2}} (\sin \varphi)^{N-2} f_N\left(\sqrt{N}A \cos \varphi\right) d\varphi + Q\left(\sqrt{N}A\right), \quad (66)$$

where $f_N(x) = \sum_{j=0}^{N-1} \exp(d(N, j, x))$, with

$$\begin{aligned} d(N, j, x) &= \frac{x^2}{2} + \ln \Gamma\left(\frac{N}{2}\right) - \ln \Gamma\left(\frac{j}{2} + 1\right) \\ &\quad - \ln \Gamma(N-j) + (N-1-j) \ln\left(\sqrt{2x}\right) - \frac{\ln 2}{2} \\ &\quad + \ln \left[1 + (-1)^j \tilde{\Gamma}\left(\frac{x^2}{2}, \frac{j+1}{2}\right)\right], \end{aligned} \quad (67)$$

and $\tilde{\Gamma}(\cdot, \cdot)$ denoting the lower incomplete Gamma function

$$\tilde{\Gamma}(x, a) = \frac{1}{\Gamma(a)} \int_0^x t^{a-1} e^{-t} dt. \quad (68)$$

This way of computing Shannon's SPB corresponds to the logarithmic domain approach proposed in [35], which avoids the numerical over- and under-flows affecting the calculation of the bound for large block lengths. By considering the parameters of the code used in the k -th channel, and by solving $P_{\text{SPB}}(N, \vartheta, A) = 1 - \eta$ with respect to γ , we obtain $\gamma_{\eta}^{\text{E}}(k)$ such that the error probability on that channel is $1 - \eta$.

REFERENCES

- [1] P. K. Gopala, L. Lai, and H. El Gamal, "On the secrecy capacity of fading channels," *IEEE Trans. Inf. Theory*, vol. 54, no. 10, pp. 4687–4698, Oct. 2008.
- [2] T. Liu, V. Prabhakaran, and S. Vishwanath, "The secrecy capacity of a class of parallel Gaussian compound wiretap channels," in *Proc. IEEE Int. Symp. Inf. Theory (ISIT)*, Toronto, Canada, Jul. 2008, pp. 116–120.
- [3] X. Tang, R. Liu, and P. Spasojevic, "On the achievable secrecy throughput of block fading channels with no channel state information at transmitter," in *Proc. 41st Annual Conf. Inf. Sciences and Systems, (CISS)*, Baltimore, MD, Mar. 2007, pp. 917–922.
- [4] F. Renna, N. Laurenti, and H. V. Poor, "Physical-layer secrecy for OFDM transmissions over fading channels," *IEEE Trans. Inf. Forensics Security*, vol. 7, no. 4, pp. 1354–1367, Aug. 2012.
- [5] —, "High SNR secrecy rates with OFDM signaling over fading channels," in *Proc. IEEE Int. Symp. Personal, Indoor and Mobile Radio Commun. (PIMRC)*, Istanbul, Turkey, Sep. 2010, pp. 2692–2697.
- [6] P.-H. Lin, S.-H. Lai, S.-C. Lin, and H.-J. Su, "On secrecy rate of the generalized artificial-noise assisted secure beamforming for wiretap channels," *IEEE J. Sel. Areas Commun.*, vol. 31, no. 9, pp. 1728–1740, Sep. 2013.

- [7] S.-C. Lin and P.-H. Lin, "On secrecy capacity of fast fading multiple-input wiretap channels with statistical CSIT," *IEEE Trans. Inf. Forensics Security*, vol. 8, no. 2, pp. 414–419, Feb 2013.
- [8] A. Suresh, A. Subramanian, A. Thangaraj, M. Bloch, and S. W. McLaughlin, "Strong secrecy for erasure wiretap channels," in *Proc. IEEE Inf. Theory Workshop (ITW)*, Dublin, Ireland, Aug. 2010.
- [9] H. Mahdaviifar and A. Vardy, "Achieving the secrecy capacity of wiretap channels using polar codes," *IEEE Trans. Inf. Theory*, vol. 57, no. 10, pp. 6428–6443, Oct. 2008.
- [10] O. O. Koyluoglu and H. El Gamal, "Polar coding for secure transmission and key agreement," *IEEE Trans. Inf. Forensics Security*, vol. 7, no. 5, pp. 1472–1483, Oct. 2012.
- [11] M. R. Bloch and J. N. Laneman, "On the secrecy capacity of arbitrary wiretap channels," in *Proc. IEEE Allerton Conf. on Commun., Control, and Computing*, Urbana, IL, Sep. 2008, pp. 818–825.
- [12] C. W. Wong, T. Wong, and J. Shea, "Secret-sharing LDPC codes for the BPSK-constrained Gaussian wiretap channel," *IEEE Trans. Inf. Forensics Security*, vol. 6, no. 3, pp. 551–564, Sep. 2011.
- [13] D. Klinc, J. Ha, S. McLaughlin, J. Barros, and B.-J. Kwak, "LDPC codes for physical layer security," in *Proc. IEEE Global Telecomm. Conf. (GLOBECOM)*, Honolulu, HI, Nov. 2009, pp. 1–6.
- [14] —, "LDPC codes for the Gaussian wiretap channel," *IEEE Trans. Inf. Forensics Security*, vol. 6, no. 3, pp. 532–540, Sep. 2011.
- [15] M. Baldi, M. Bianchi, and F. Chiaraluce, "Non-systematic codes for physical layer security," in *Proc. IEEE Information Theory Workshop (ITW)*, Dublin, Ireland, Aug. 2010.
- [16] —, "Increasing physical layer security through scrambled codes and ARQ," in *Proc. IEEE Int. Conf. Commun. (ICC)*, Kyoto, Japan, Jun. 2011.
- [17] —, "Coding with scrambling, concatenation, and HARQ for the AWGN wire-tap channel: A security gap analysis," *IEEE Trans. Inf. Forensics Security*, vol. 7, no. 3, pp. 883–894, Jun. 2012.
- [18] W. K. Harrison, J. Almeida, S. McLaughlin, and J. Barros, "Coding for cryptographic security enhancement using stopping sets," *IEEE Trans. Inf. Forensics Security*, vol. 6, no. 3, pp. 575–584, Sep. 2011.
- [19] X. Zhou, M. R. McKay, B. Maham, and A. Hjørungnes, "Rethinking the secrecy outage formulation: A secure transmission design perspective," *IEEE Commun. Letters*, vol. 15, no. 3, pp. 302–304, Mar. 2011.
- [20] M. Bloch and J. Barros, *Physical-Layer Security. From Information Theory to Security Engineering*. Cambridge, UK: Cambridge University Press, 2011.
- [21] Z. Li, R. Yates, and W. Trappe, "Secrecy capacity of independent parallel channels," in *Proc. Annual Allerton Conf. Commun., Contr., Computing*, Monticello, IL, 2006.
- [22] E. A. Jorswieck and A. Wolf, "Resource allocation for the wire-tap multi-carrier broadcast channel," in *Proc. IEEE Int. Conf. on Telecommunications (ICT)*, St. Petersburg, Russia, Jun. 2008, pp. 1–6.
- [23] D. Tse and P. Viswanath, *Fundamentals of Wirelss Communication*. Cambridge, UK: Cambridge University Press, 2005.
- [24] W. K. Harrison, J. Almeida, M. R. Bloch, S. W. McLaughlin, and J. Barros, "Coding for secrecy: An overview of error-control coding techniques for physical-layer security," *IEEE Signal Proc. Mag.*, vol. 30, no. 5, pp. 41–50, Sep. 2013.
- [25] R. Garelo, P. Pierleoni, and S. Benedetto, "Computing the free distance of turbo codes and serially concatenated codes with interleavers: Algorithms and applications," *IEEE J. Sel. Areas Commun.*, vol. 19, no. 5, pp. 800–812, May 2001.
- [26] A. Valembois and M. P. C. Fossorier, "Sphere-packing bounds revisited for moderate block lengths," *IEEE Trans. Inf. Theory*, vol. 50, no. 12, pp. 2998–3014, Dec. 2004.

- [27] J. Jiang and K. R. Narayanan, "Iterative soft-input soft-output decoding of Reed-Solomon codes by adapting the parity-check matrix," *IEEE Trans. Inf. Theory*, vol. 52, no. 8, pp. 3746–3756, Aug. 2006.
- [28] S. B. Wicker, *Error Control Systems for Digital Communication and Storage*. Upper Saddle River, NJ: Prentice Hall Inc., 1995.
- [29] X. Y. Hu, E. Eleftheriou, and D. Arnold, "Progressive edge-growth Tanner graphs," in *Proc. IEEE Global Telecomm. Conf. (GLOBECOM)*, San Antonio, TX, Nov. 2001, pp. 995–1001.
- [30] J. Hagenauer, E. Offer, and L. Papke, "Iterative decoding of binary block and convolutional codes," *IEEE Trans. Inf. Theory*, vol. 42, no. 2, pp. 429–445, Mar. 1996.
- [31] C. Snow, L. Lampe, and R. Schober, "Error rate analysis for coded multicarrier systems over quasi-static fading channels," in *Proc. IEEE Global Telecomm. Conf. (GLOBECOM)*, San Francisco, CA, Nov. 2006.
- [32] F. Yilmaz and M.-S. Alouini, "Product of shifted exponential variates and outage capacity of multicarrier systems," in *Proc. European Wireless Conf.*, Aalborg, Denmark, May 2009.
- [33] L. D. Baumert and L. R. Welch, "Minimum-weight codewords in the (128,64) BCH code," NASA, Tech. Rep. DSN Progress Report 42-42, Dec. 1977.
- [34] C. E. Shannon, "Probability of error for optimal codes in a Gaussian channel," *Bell Syst. Tech. J.*, vol. 38, no. 3, pp. 611–656, May 1959.
- [35] G. Wiechman and I. Sason, "An improved sphere-packing bound for finite-length codes over symmetric memoryless channels," *IEEE Trans. Inf. Theory*, vol. 54, no. 5, pp. 1962–1990, May 2008.