

# Revisiting the Complexity of And/Or Graph Solution

Maise Dantas da Silva, Fábio Protti, Uéverton dos Santos Souza  
*Fluminense Federal University, Niterói, RJ, Brazil*  
maisedantas@id.uff.br, fabio@ic.uff.br, usouza@ic.uff.br

## Abstract

This paper presents a study on two data structures that have been used to model several problems in computer science: and/or graphs and x-y graphs. An and/or graph is an acyclic digraph containing a source (a vertex that reaches all other vertices by directed paths), such that every vertex  $v$  has a label  $f(v) \in \{\mathbf{and}, \mathbf{or}\}$  and (weighted) edges represent dependency relations between vertices: a vertex labeled **and** depends on all of its out-neighbors (conjunctive dependency), while a vertex labeled **or** depends on only one of its out-neighbors (disjunctive dependency). X-y graphs are defined as a natural generalization of and/or graphs: every vertex  $v_i$  of an x-y graph has a label  $x_i-y_i$  to mean that  $v_i$  depends on  $x_i$  of its  $y_i$  out-neighbors. We analyze the complexity of the optimization problems MIN-AND/OR and MIN-X-Y, which consist of finding solution subgraphs of optimal weight for and/or and x-y graphs, respectively. A solution subgraph  $H$  of an and/or-graph must contain the source and obey the following rule: if an **and**-vertex (resp. **or**-vertex) is included in  $H$  then all (resp. one) of its out-edges must also be included in  $H$ . Analogously, if a vertex  $v_i$  is included in a solution subgraph  $H$  of an x-y graph then  $x_i$  of its  $y_i$  out-edges must also be included in  $H$ . Motivated by the large applicability as well as the hardness of MIN-AND/OR and MIN-X-Y, we study new complexity aspects of such problems, both from a classical and a parameterized point of view. We prove that MIN-AND/OR remains NP-hard even for a very restricted family of and/or graphs where edges have weight one and **or**-vertices have out-degree at most two (apart from other property related to some in-degrees), and that deciding whether there is a solution subtree with weight exactly  $k$  of a given x-y tree is also NP-hard. We also show that: (i) the parameterized problem MIN-AND/OR( $k, r$ ), which asks whether there is a solution subgraph of weight at most  $k$  where every **or**-vertex has at most  $r$  out-edges with the same weight, is FPT; (ii) the parameterized problem MIN-AND/OR<sup>0</sup>( $k$ ), whose domain

includes and/or graphs allowing zero-weight edges, is W[2]-hard; (iii) the parameterized problem MIN-X-Y( $k$ ) is W[1]-hard.

## 1 Introduction

In this paper we consider the complexity of problems involving two important data structures, *and/or graphs* and *x-y graphs*. An and/or graph is an acyclic digraph containing a source (a vertex that reaches all other vertices by directed paths), such that every vertex  $v \in V(G)$  has a label  $f(v) \in \{\mathbf{and}, \mathbf{or}\}$ . In such digraphs, edges represent dependency relations between vertices: a vertex labeled **and** depends on all of its out-neighbors (conjunctive dependency), while a vertex labeled **or** depends on only one of its out-neighbors (disjunctive dependency).

We define x-y graphs as a generalization of and/or graphs: every vertex  $v_i$  of an x-y graph has a label  $x_i$ - $y_i$  to mean that  $v_i$  depends on  $x_i$  of its  $y_i$  out-neighbors. Given an and/or graph  $G$ , an equivalent x-y graph  $G'$  is easily constructed as follows: sinks of  $G$  are vertices with  $x_i = y_i = 0$ ; **and**-vertices satisfy  $x_i = y_i$ ; and **or**-vertices satisfy  $x_i = 1$ .

In representations of and/or graphs, **and**-vertices have an arc around its out-edges. Figure 1 shows in (a) an example of and/or graph, and in (b) an example of x-y graph.

And/or graphs were used for modeling problems originated in the 60's within the domain of Artificial Intelligence [17, 19]. Since then, they have successfully been applied to other fields, such as Operations Research, Automation, Robotics, Game Theory, and Software Engineering, to model cutting problems [15], interference tests [11], failure dependencies [4], robotic task plans [5], assembly/disassembly sequences [7], game trees [13], software versioning [6], and evaluation of boolean formulas [14]. With respect to x-y graphs, they correspond to the *x-out-of-y model* of resource sharing in distributed systems [3].

In addition to the above applications, special directed hypergraphs named *F-graphs* are equivalent to and/or graphs [10]. An F-graph is a directed hypergraph where hyperarcs are called *F-arcs* (for *forward arcs*), which are of the form  $E_i = (S_i, T_i)$  with  $|S_i| = 1$ . An F-graph  $H$  can be easily transformed into an and/or graph as follows: for each vertex  $v \in V(H)$  do  $f(v)=\mathbf{or}$ ; for each *F*-arc  $E_i = (S_i, T_i)$ , where  $|T_i| \geq 2$ , do: create an **and**-vertex  $v_i$ , add an edge  $(u, v_i)$  where  $\{u\} = S_i$ , and add an edge  $(v_i, w_j)$  for all  $w_j \in T_i$ .

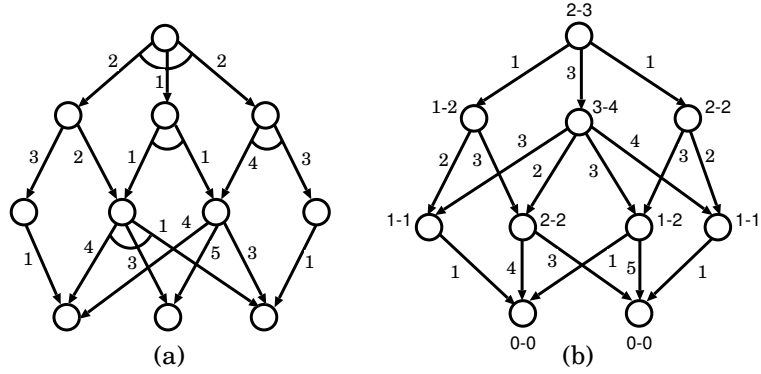

Figure 1: (a) A weighted and/or graph; (b) A weighted x-y graph.

In this work, we denote by  $O_v$  and  $I_v$ , respectively, the subsets of out-neighbors and in-neighbors of a vertex  $v$ . Also,  $\tau(e)$  denotes the weight of an edge  $e$ , and we define the weight of a graph as the sum of the weights of its edges. We assume  $|V(G)| = n$  and  $|E(G)| = m$ .

The optimization problems associated with and/or graphs and x-y graphs are formally defined below.

#### MIN-AND/OR

*Instance:* An and/or graph  $G = (V, E)$  where each edge  $e$  has an integer weight  $\tau(e) > 0$ .

*Goal:* Determine the minimum weight of a subdigraph  $H = (V', E')$  of  $G$  (*solution subgraph*) satisfying the following properties:

- $s \in V'$ ;
- if a non-sink node  $v$  is in  $V'$  and  $f(v)=\text{and}$  then every out-edge of  $v$  belongs to  $E'$ ;
- if a non-sink node  $v$  is in  $V'$  and  $f(v)=\text{or}$  then exactly one out-edge of  $v$  belongs to  $E'$ .

#### MIN-X-Y

*Instance:* An x-y graph  $G = (V, E)$  where each edge  $e$  has an integer weight  $\tau(e) > 0$ .

*Goal:* Determine the minimum weight of a subdigraph  $H = (V', E')$  of  $G$  satisfying the following properties:

- $s \in V'$ ;
- for every non-sink node  $v_i$  in  $V'$ ,  $x_i$  of its  $y_i$  out-edges belong to  $E'$ .

In 1974, Sahni [18] showed that MIN-AND/OR is NP-hard via a reduction

from 3-SAT. Therefore, MIN-X-Y is also NP-hard.

There are three trivial cases for which MIN-AND/OR can be solved in polynomial time:

1. All vertices of  $G$  are **and**-vertices. In this case,  $G$  is the solution subgraph.
2. All vertices of  $G$  are **or**-vertices. In this case, the optimal solution subgraph is a shortest path between  $s$  and a sink.
3.  $G$  is a tree (*and/or tree*). In this case, the weight of the optimal solution subgraph of  $G$ , given by  $c(s)$ , can be obtained in  $O(n)$  time via the recurrence relation below:

$$c(v_i) = \begin{cases} 0, & \text{if } v_i \text{ is a sink;} \\ \sum_{v_j \in O_{v_i}} (\tau(v_i, v_j) + c(v_j)), & \text{if } f(v_i) = \mathbf{and}; \\ \min_{v_j \in O_{v_i}} \{\tau(v_i, v_j) + c(v_j)\}, & \text{if } f(v_i) = \mathbf{or}. \end{cases}$$

Other three trivial cases of MIN-AND/OR can be listed: if every **or**-vertex has out-degree one then **or**-vertices can be converted into **and**-vertices, and case 1 above applies; if every **and**-vertex has out-degree one then **and**-vertices can be converted into **or**-vertices, and case 2 applies; finally, if every vertex with in-degree greater than 1 is a sink then the recurrence presented in the case 3 can be used.

As noted by Adelson-Velsky in [1], the problem MIN-AND/OR has interesting connections with real-world applications in scheduling. An example is the work [2], which employs and/or graphs to model real-time scheduling of tasks in computer communication systems. Such a scheduling problem (AND/OR-SCHEDULING) generalizes the classical shortest-path and critical-path problems in graphs [1]. Given a weighted and/or graph, AND/OR-SCHEDULING consists of finding the earliest starting times  $t(v_i)$ , for all  $v_i \in V(G)$ , satisfying the following conditions:

- $t(v_i) = 0$ , if  $v_i$  is a sink;
- $t(v_i) \geq \max_{v_j \in O_{v_i}} \{\tau(v_i, v_j) + t(v_j)\}$ , if  $f(v_i) = \mathbf{and}$ ;
- $t(v_i) \geq \min_{v_j \in O_{v_i}} \{\tau(v_i, v_j) + t(v_j)\}$ , if  $f(v_i) = \mathbf{or}$ .

MIN-AND/OR can thus be viewed as a variant of AND/OR-SCHEDULING: while the latter aims at determining the minimum *time* necessary to perform a task, the former aims at determining the minimum *cost* to perform it. Since AND/OR-SCHEDULING is solvable in polynomial time [1], its solution can be used as a practical lower bound for MIN-AND/OR. In addition, the recurrence equations for and/or trees lead to a bottom-up dynamic programming algorithm to find in polynomial time a feasible solution (and hence an upper bound) of MIN-AND/OR.

An *x-y tree* is an x-y graph where no two vertices share a common out-neighbor. As for MIN-AND/OR, MIN-X-Y can be solved in  $O(n)$  time when the input x-y graph is an x-y tree  $T = (V, E)$ . To show this, observe first that the minimum weight of a solution subtree is given by a similar recurrence (shown below), since the optimal solution of an x-y tree rooted at a vertex  $v_i$  is obtained by  $x_i$  subtrees of  $v_i$ :

$$c(v_i) = \begin{cases} 0, & \text{if } v_i \text{ is a sink;} \\ \min_{X \subseteq O_{v_i}, |X|=x_i} \left\{ \sum_{x \in X} (\tau(v_i, x) + c(x)) \right\} & \end{cases}$$

For each non-sink  $v_i$ , we need to compute the sum of the  $x_i$  smallest values  $\tau(v_i, x) + c(x)$  among its children; determining the  $x_i$ -th smallest value takes  $O(y_i)$  time, and thus selecting the  $x_i$  smallest values takes  $O(y_i)$  time as well. Then the entire bottom-up procedure takes overall  $\sum_{i=1}^n O(y_i) = O(n)$  time.

Motivated by the large applicability as well as the hardness of MIN-AND/OR and MIN-X-Y, we study new complexity aspects of such problems, both from a classical and a parameterized point of view. The latter is justified by the fact that many applications are concerned with satisfying a low cost limit. The remainder of this work is organized as follows. In Section 2, we prove that MIN-AND/OR remains NP-hard even for a very restricted family of and/or graphs where edges have weight one and or-vertices have out-degree at most two (apart from another property related to some in-degrees), and that deciding whether there is a solution subtree with weight exactly  $k$  of a given x-y tree is NP-hard. In Section 3, we show that: (i) the parameterized problem MIN-AND/OR( $k, r$ ), which asks whether there is a solution subgraph of weight at most  $k$  where every or-vertex has at most  $r$  out-edges with the same weight, is FPT; (ii) the parameterized problem MIN-AND/OR<sup>0</sup>( $k$ ), whose domain includes and/or graphs allowing zero-weight edges, is W[2]-hard; (iii) the parameterized problem MIN-X-Y( $k$ ) is W[1]-hard.

## 2 NP-hardness results

We now consider a very restricted family of and/or graphs, defined as follows: Let  $\mathcal{F}$  be the set of all and/or graphs  $G$  satisfying the following properties: every edge in  $E(G)$  has weight one; every **or**-vertex in  $V(G)$  has out-degree at most two; and vertices in  $V(G)$  with in-degree greater than one are within distance at most one of a sink. We show that even for such and/or graphs the problem MIN-AND/OR remains NP-hard.

**Theorem 1** *MIN-AND/OR restricted to  $\mathcal{F}$  is NP-hard.*

**Proof.** The proof uses a reduction from VERTEX COVER, shown to be NP-hard by Karp in [12]. Given a graph  $G = (V, E)$ , we construct an and/or graph  $G' = (V', E')$  in  $\mathcal{F}$  as follows. Suppose  $V = \{v_1, \dots, v_n\}$  and  $E = \{e_1, \dots, e_m\}$ . Create a source  $s \in V'$  with  $f(s) = \text{and}$ . For each edge  $e_i \in E$  create an out-neighbor  $w_{e_i} \in V'$  of  $s$  with  $f(w_{e_i}) = \text{or}$ . For each vertex  $v_j \in V$  create a vertex  $w_{v_j} \in V'$  with  $f(w_{v_j}) = \text{or}$ , and add an edge  $(w_{e_i}, w_{v_j})$  in  $E'$  if and only if  $e_i$  is incident to  $v_j$ . Finally, create an out-neighbor  $t_{v_j}$  for each vertex  $w_{v_j} \in V'$  and assign  $\tau(e) = 1$  for all  $e \in E'$ . Figure 2 illustrates in (a) a graph  $G$  and in (b) the and/or graph  $G'$  obtained by the construction above.

We now show that there is a vertex cover of size at most  $k$  in  $G$  if and only if there is a solution subgraph of weight at most  $2m + k$  in  $G'$ . Suppose first that  $G$  has a vertex cover  $C$  of size at most  $k$ . A suitable solution subgraph  $H$  of  $G'$  can be obtained as follows. Vertex  $s$  must belong to  $V(H)$  by definition. Since  $s$  is an **and**-vertex, its  $m$  out-edges must belong to  $E(H)$ . But every out-neighbor  $w_{e_i}$  of  $s$  is an **or**-vertex; then exactly one of its out-edges in  $G'$ , say  $(w_{e_i}, w_{v_j})$ , must also belong to  $E(H)$ . We choose edge  $(w_{e_i}, w_{v_j})$  if and only if  $v_j \in C$ . At this point, at most  $|C|$  vertices  $w_{v_j}$  belong to  $V(H)$ . Now each  $w_{v_j}$  has exactly one out-neighbor which is a sink; then for each  $w_{v_j}$  we add only one additional out-edge of it. Hence  $H$  has weight  $2m + |C| \leq 2m + k$ .

Conversely, suppose that  $G'$  contains a solution subgraph  $H$  of weight at most  $2m + k$ . By construction,  $m$  out-edges of  $s$  belong to  $E(H)$ , and for each vertex  $w_{e_i}$  in  $V(H)$  exactly one of its out-edges is in  $E(H)$ . Since each vertex  $w_{v_j}$  in  $V(H)$  must have one out-neighbor,  $V(H)$  contains at most  $k$  vertices  $w_{v_j}$ . Let  $X$  be the subset of vertices of the form  $w_{v_j}$  in  $V(H)$ , and  $C$  a subset of vertices of  $G$  such that  $v_j \in C$  if and only if  $w_{v_j} \in X$ . Every vertex  $w_{e_i}$  in  $V(H)$  has an out-neighbor  $w_{v_j}$  in  $V(H)$ , and by construction of  $G'$  a vertex  $w_{e_i}$  is an in-neighbor of  $w_{v_j}$  if and only if  $e_i$  is incident to  $v_j$

in  $G$ . Since every  $w_{e_i}$  in  $V(H)$  has an out-neighbor  $w_{v_j} \in X$ , every edge  $e_i$  in  $G$  is incident to a vertex  $v_j \in C$ . Hence  $C$  is a vertex cover of  $G$  and  $|C| = |X| \leq k$ .  $\square$

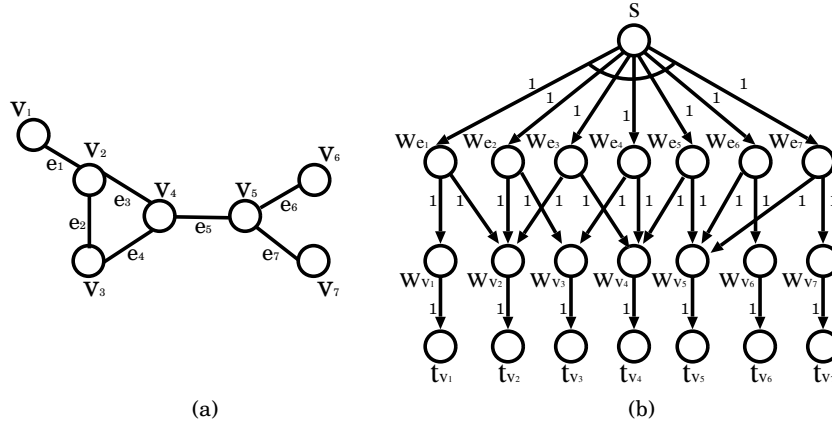

Figure 2: A graph  $G$  and the corresponding and/or graph  $G'$ .

To conclude this section, we show an interesting result concerning x-y trees. Although MIN-X-Y can be solved in linear time when restricted to x-y trees, deciding whether there is a solution subtree with weight exactly  $k$  of a given x-y tree is NP-hard.

**Theorem 2** *Let  $T$  be an x-y tree. Deciding whether there is a solution subtree  $T'$  of  $T$  with weight exactly  $k$  is NP-hard.*

**Proof.** The proof uses a reduction from the SUBSET SUM problem, shown to be NP-hard by Karp in [12]. It consists of deciding whether in a set of integers there is a subset  $S$  of cardinality  $p$  such that the sum of the integers in  $S$  is equal to an integer value  $q$ . Given a set of integers  $Z = \{z_1, z_2, \dots, z_n\}$ , an integer  $q$  and a positive integer  $p$ , we construct an x-y tree  $T = (V, E)$  such that there is a solution subtree  $T'$  of  $T$  of weight exactly  $k = q + p$  if and only if there is a subset  $Z'$  of  $Z$  such that  $|Z'| = p$  and the sum of the elements in  $Z'$  equals  $q$ . The construction is as follows. Create a source vertex  $s \in V(T)$  with label  $p-n$ . For each element  $z_i \in Z$ , create a vertex  $u_i \in V(T)$  with label  $1-1$  and add an edge  $e_i = (s, u_i) \in E(T)$  where

$\tau(e_i) = 1$ . Finally, for each element  $z_i \in Z$ , create a vertex  $w_i$  with label 0-0 and add an edge  $f_i = (u_i, w_i)$  with  $\tau(f_i) = z_i$ .

Suppose that there is a subset  $Z'$  of  $Z$  such that  $|Z'| = p$  and the sum of its elements equals  $q$ . Since the source vertex  $s$  has label  $p-n$ , a solution subtree  $T'$  is constructed as follows:  $s \in V(T')$ , and for each  $z_i \in Z'$  add edges  $(s, u_i)$  and  $(u_i, w_i)$  to  $E(T')$ , where  $u_i$  and  $w_i$  are vertices associated with  $z_i$  by construction. Observe that each out-edge  $e_i$  of  $s$  satisfies  $\tau(e_i) = 1$ , and each edge  $f_i = (u_i, w_i)$  satisfies  $\tau(f_i) = z_i$ . Hence the weight of  $T'$  is  $k = q + p$ .

Conversely, suppose that there is a solution subtree  $T'$  of  $T$  with weight  $p+q$ . By definition,  $s \in V(T')$ , and there are  $p$  out-edges  $e_i$  of  $s$  belonging to  $E(T')$ , each one with weight equal to 1. Let  $E'$  be the subset of edges of the form  $f_i = (u_i, w_i)$  in  $E(T')$ . Note that  $|E'| = p$  and  $\sum_{f_i \in E'} \tau(e_i) = q$ . Define  $Z' = \{z_i \in Z \mid f_i = (u_i, w_i) \in E'\}$ . Clearly,  $|Z'| = p$  and  $\sum_{z_i \in Z'} z_i = q$ .  $\square$

### 3 Parameterized complexity results

The Parameterized Complexity Theory was proposed by Downey and Fellows [8] as a promising alternative to deal with NP-hard problems described by the following general form [16]: given an object  $x$  and a nonnegative integer  $k$ , does  $x$  have some property that depends only on  $k$  (and not on the size of  $x$ )? In parameterized complexity theory,  $k$  is fixed as the *parameter*, considered to be *small* in comparison with the size  $|x|$  of object  $x$ . It may be of high interest for some problems to ask whether they admit deterministic algorithms whose running times are exponential with respect to  $k$  but polynomial with respect to  $|x|$ .

**Definition 1** [9] *A parameterized problem  $\Pi$  is fixed-parameter tractable, or FPT, if the question “ $(x, k) \in \Pi$ ?” can be decided in running time  $f(|k|) \cdot |x|^{O(1)}$ , where  $f$  is an arbitrary function on nonnegative integers. The corresponding complexity class is called FPT.*

**Definition 2** [9] *Let  $\Pi = (I, k)$  be a parameterized problem, where instance  $I$  is asked to have a solution of size  $k$ . Reduction to problem kernel means to replace instance  $(I, k)$  by a reduced instance  $(I', k')$  (called problem kernel) such that  $k' \leq ck$  for a constant  $c$ ,  $|I'| \leq g(k)$  for some function  $g$  only depending on  $k$ , and  $(I, k) \in \Pi$  if and only if  $(I', k') \in \Pi$ . Furthermore, the reduction from  $(I, k)$  to  $(I', k')$  is computable in polynomial time.*



**Definition 3** [9] *Let  $(Q, k)$  and  $(Q', k')$  be parameterized problems over alphabets  $\Sigma$  and  $\Sigma'$ , respectively. An FPT-reduction from  $(Q, k)$  to  $(Q', k')$  is a mapping  $R : \Sigma^* \rightarrow (\Sigma')^*$  such that:*

1. *For all  $x \in \Sigma^*$ , it holds that  $x \in Q$  if and only if  $R(x) \in Q'$ ;*
2.  *$R$  is computable by an FPT-algorithm (with respect to  $k$ );*
3. *There is a computable function  $g : N \rightarrow N$  such that  $k'(R(x)) \leq g(k(x))$  for all  $x \in \Sigma^*$ .*

In addition to the FPT class, some classes of parameterized problems are defined according to their parameterized intractability level. These classes are organized in a *W-hierarchy* ( $\text{FPT} \subseteq \text{W}[1] \subseteq \text{W}[2] \subseteq \dots \subseteq \text{W}[P]$ ), and it is conjectured that each of the containments is proper [8]. If  $P = \text{NP}$  then the hierarchy collapses [8].

We define *C-hardness* and *C-completeness* of a parameterized problem  $(Q, k)$  as in classical complexity theory:  $(Q, k)$  is *C-hard* under FPT-reductions if every problem in *C* is FPT-reducible to  $(Q, k)$ ;  $(Q, k)$  is *C-complete* under FTP-reductions if  $(Q, k) \in C$  and  $(Q, k)$  is *C-hard*.

To cite a few examples where parameter  $k$  is associated with the size of a solution,  $\text{VERTEX COVER}(k)$  is FPT,  $\text{CLIQUE}(k)$  is  $\text{W}[1]$ -complete, and  $\text{DOMINATING SET}(k)$  is  $\text{W}[2]$ -complete (see [8]). Several other results can be found in [8].

### 3.1 The problem $\text{MIN-AND/OR}(k, r)$

By Theorem 1,  $\text{MIN-AND/OR}$  remains NP-hard even when each **or**-vertex has at most two out-neighbors. Let  $\text{MIN-AND/OR}(k, r)$  stand for the parameterized version of  $\text{MIN-AND/OR}$  where every **or**-vertex of the input graph has at most  $r$  out-edges with the same weight and it is asked whether there is a solution subgraph of weight at most  $k$ . Note that the restriction “at most  $r$  out-edges with the same weight” imposed on **or**-vertices is in fact a far more general situation than simply restricting the out-degree of vertices to a constant. In this subsection, we show that  $\text{MIN-AND/OR}(k, r)$  is in FPT for parameters  $k$  and  $r$ .

**Theorem 3**  $\text{MIN-AND/OR}(k, r)$  *is reducible to a problem kernel in time  $O(m)$ .*

**Proof.** The proof is based on some correct reduction rules that must be applied once in the order given below:

1. for each **and**-vertex  $v_i$ , if  $\sum_{v_j \in O_{v_i}} \tau(v_i, v_j) > k$  then remove it;
2. for each edge  $e \in E(G)$ , if  $\tau(e) > k$  then remove it;
3. for every vertex  $v_i \neq s$ , if the weight of a shortest path from  $s$  to  $v_i$  is greater than  $k$  then remove it;
4. if some vertex becomes unreachable from  $s$  then remove it;
5. for every vertex that becomes a sink, assign weight  $k + 1$  to all its in-edges;
6. for each **and**-vertex such that some of its out-neighbors has been removed, assign weight  $k + 1$  to all its in-edges.

Let  $G'$  be the graph obtained by applying the above reduction rules. The reduction rules have modified or removed only vertices and edges that could not be part of a solution subgraph of maximum weight  $k$  in  $G$  and vice-versa. Thus, if  $S$  is a solution subgraph of weight at most  $k$  in  $G'$  then  $S$  is also a solution subgraph of weight at most  $k$  in  $G$ . Note that the running time to apply the above reduction rules is  $O(m)$ , since  $G$  is acyclic.

In  $G'$  the longest shortest-path from  $s$  to a sink has cost at most  $k$ , and each vertex has at most  $kr$  out-neighbors. Thus,  $G'$  will have a maximum number of vertices if: (i) all its non-sink vertices have out-degree equal to  $kr$ , (ii) no vertex shares a same out-neighbor with another vertex, and (iii) the cost of the shortest path from  $s$  to any sink is  $k$ . Hence the number of vertices at distance  $i$  from  $s$  is at most  $(kr)^i$ , that is, the total number of the vertices in  $G'$  is at most  $O((kr)^{k+1})$ .

Since (a) the reduction rules can be applied in  $O(m)$  time, (b) the size of  $G'$  is a function of the parameters  $k$  and  $r$ , and (c) a solution subgraph of maximum weight  $k$  in  $G'$  is also a solution subgraph of maximum weight  $k$  in  $G$ , we conclude that  $G'$  is a kernel for MIN-AND/OR( $k, r$ ). Hence MIN-AND/OR( $k, r$ ) is reducible to a problem kernel in  $O(m)$  time.  $\square$

**Corollary 4** MIN-AND/OR( $k, r$ ) is in FPT.  $\square$

### 3.2 And/or graphs with zero-weight edges

In this subsection, we consider the family  $\mathcal{Z}$  of and/or graphs where zero-weight edges are allowed. This can model practical situations in which some decisions can be taken at no cost, although in the original definition of MIN-AND/OR [18] all edges have positive weights. Let MIN-AND/OR<sup>0</sup>( $k$ ) stand for

the parameterized version of MIN-AND/OR applied to and/or graphs in  $\mathcal{Z}$ , and DOMINATING SET( $c$ ) for the W[2]-hard parameterized problem where it is asked whether an input graph  $Q$  has a dominating set of size at most  $c$  (see [8]).

**Theorem 5** DOMINATING SET( $c$ ) is FPT-reducible to MIN-AND/OR<sup>0</sup>( $k$ ).

**Proof.** Given an instance  $(Q, c)$  of DOMINATING SET( $c$ ), we construct an instance  $(G, k)$  of MIN-AND/OR<sup>0</sup>( $k$ ) as follows: (a) create a source vertex  $s$  in  $G$  where  $f(s) = \text{and}$ ; (b) for each vertex  $v_i \in V(Q)$ , create three associated vertices  $u_i, w_i, t_i$  where  $f(u_i) = \text{or}$ ,  $f(w_i) = \text{and}$ ,  $f(t_i) = \text{or}$ ; (c) for each vertex  $u_i \in V(G)$ , add an edge  $(s, u_i)$  with  $\tau(s, u_i) = 0$ , and add an edge  $(u_i, w_j)$  with  $\tau(u_i, w_j) = 0$  if and only if  $i = j$  or  $(v_i, v_j) \in E(Q)$ ; (d) create an edge  $(w_i, t_i) \in E(G)$  with  $\tau(w_i, t_i) = 1$  for all  $i \in \{1, \dots, n\}$ ; (e) finally, set  $k = c$ .

If  $Q$  contains a dominating set  $C$  such that  $|C| \leq c$  then it is possible to construct a solution subgraph  $H$  of  $G$  with weight at most  $k$  as follows:  $s$  and all of its out-neighbors belong to  $V(H)$ ; for each vertex  $u_i \in V(H)$ , include in  $V(H)$  an out-neighbor  $w_j$  of  $u_i$  if and only if  $v_j \in C$ ; and for each vertex  $w_j \in V(H)$ , add an edge  $(w_j, t_j)$  to  $E(H)$ . Since  $|C| \leq c = k$  then at most  $k$  edges  $(w_j, t_j)$  belong to  $E(H)$ . Hence  $H$  has weight at most  $k$ .

Conversely, if  $G$  has a solution subgraph  $H$  with weight at most  $k$  then it is possible obtain a dominating set  $C$  of  $Q$  as follows: a vertex  $v_i$  of  $Q$  belongs to  $C$  if and only if  $w_i$  belongs to  $V(H)$ . Since  $H$  is a solution subgraph, by definition every non-sink or-vertex has exactly one out-neighbor. Hence  $H$  has at most  $k$  vertices  $w_i$  and  $|C| \leq k$ .  $\square$

Figure 3 illustrates in (a) an instance of DOMINATING SET and in (b) the corresponding instance of MIN-AND/OR<sup>0</sup>( $k$ ) obtained by the construction above.

**Corollary 6** MIN-AND/OR<sup>0</sup>( $k$ ) is W[2]-hard.  $\square$

### 3.3 The problem MIN-X-Y( $k$ )

Let MIN-X-Y( $k$ ) stand for the parameterized version of MIN-X-Y, where it is asked whether there is a solution subgraph of weight at most  $k$ , and CLIQUE( $c$ ) for the W[1]-hard parameterized problem where it is asked whether the input graph  $Q$  has a clique of size  $c$  (see [8]).

**Theorem 7** CLIQUE( $c$ ) is FPT-reducible to MIN-X-Y( $k$ ).

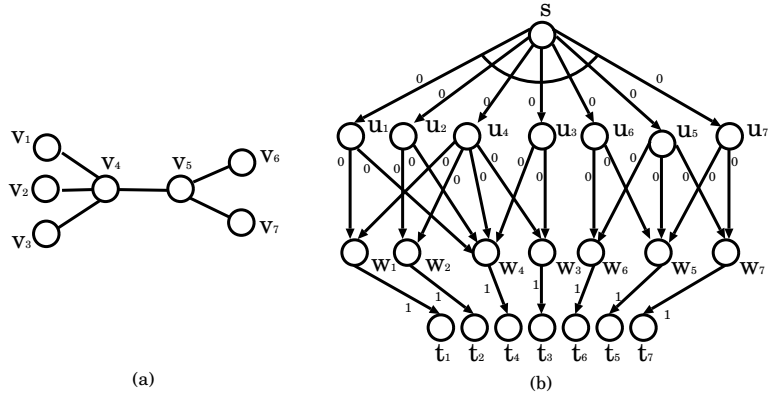

Figure 3: An instance of DOMINATING SET( $c$ ) in (a), and the corresponding instance of MIN-AND/OR<sup>0</sup>( $k$ ) in (b).

**Proof.** Given an instance  $(Q, c)$  of CLIQUE( $c$ ), we construct an instance  $(G, k)$  of MIN-X-Y( $k$ ) as follows:

- create a source vertex  $s$  in  $G$ ;
- create a set  $\{u_1, u_2, \dots, u_n\}$  of out-neighbors of  $s$ , where  $n = |V(Q)|$  (vertex  $u_i$  of  $G$  is associated with vertex  $v_i$  in  $Q$ );
- for each vertex  $u_i$ , create two out-neighbors  $z_i$  and  $w_i$  of  $u_i$ ;
- for each vertex  $z_i$ , create an edge  $(z_i, w_j)$  if and only if  $v_j$  and  $v_i$  are neighbors in  $Q$ ;
- for each vertex  $w_i$ , create an out-neighbor  $t_i$  of  $w_i$  ( $t_i$  is a sink);
- if  $v_i \in V(Q)$  has degree less than or equal to  $c - 1$  then  $\tau(s, u_i) = c^2 + 3c + 1$  else  $\tau(s, u_i) = 1$ ; for all other edges in  $G$  their weights are 1;
- $s$  has label  $c-n$ ;
- every vertex  $u_i$  has label 2-2;
- every vertex  $w_i$  has label 1-1;
- every vertex  $t_i$  has label 0-0;

- for each vertex  $z_i$ , if  $d(v_i) \geq c - 1$  then  $z_i$  is labeled  $(c - 1) - d(v_i)$ , otherwise  $z_i$  is labeled  $d(v_i) - d(v_i)$  (where  $d(v_i)$  is the number of neighbors of  $v_i$  in  $Q$ );
- set  $k = c^2 + 3c$ .

Figure 4 illustrates in (a) a graph  $Q$ , and in (b) the corresponding graph  $G$ .

Observe that the construction of  $G$  can be done in  $O(m)$  time, since  $|V(G)| = 4|V(Q)| + 1$ . We show that  $Q$  contains a clique of size  $c$  if and only if  $G$  contains a solution subgraph of size less than or equal to  $k$ .

If  $Q$  contains a set of vertices  $\{v_1, v_2, \dots, v_c\}$  forming a clique  $C$  of size  $c$ , then a solution subgraph  $H$  of  $G$  is constructed as follows. Since  $s$  is a vertex with label  $c - n$ , choose  $\{u_1, u_2, \dots, u_c\}$  to be the out-neighbors of  $s$  in  $H$ . Now each vertex  $u_i$  has label 2-2, and thus vertices  $w_1, w_2, \dots, w_c$  and  $z_1, z_2, \dots, z_c$  are also part of the solution subgraph  $H$ . This implies that vertices  $t_1, t_2, \dots, t_c$  belong to  $V(H)$  as well. At this point,  $H$  already contains  $4c$  edges of weight 1. Since each vertex  $z_i$  depends on  $c - 1$  out-neighbors, choose an out-neighbor  $w_j$  of  $z_i$  if and only if  $v_j \in C$ . Note that out-edges of vertices  $z_1, z_2, \dots, z_c$  add weight  $c(c - 1)$  to  $H$ . In addition, selected out-neighbors of each vertex  $z_i$  were already in  $H$  before their choice. Hence the weight of  $H$  is  $c(c - 1) + 4c = c^2 + 3c = k$ .

Conversely, suppose that  $G$  contains an optimal solution subgraph  $H$  of weight at most  $k \leq c^2 + 3c$ . Note that  $H$  is a solution subgraph such that: (i)  $s$  has  $c$  out-neighbors  $u_i$ ; (ii) each out-neighbor  $u_i$  of  $s$  has two out-neighbors  $z_i$  and  $w_i$ ; (iii) each one of the  $c$  vertices  $z_i$  has  $c - 1$  out-neighbors. From these observations,  $H$  contains so far at least  $c^2 + 2c$  edges, that is,  $H$  contains at most  $c$  vertices  $w_i$ . By construction, if  $w_i \in V(H)$  then vertices  $u_i$  and  $z_i$  also belong to  $V(H)$ ; but since there is no edge between  $z_i$  and  $w_i$ ,  $H$  contains exactly  $c$  vertices  $w_i$ , and  $(z_i, w_j) \in E(H)$  for all  $w_j \neq w_i$  belonging to  $V(H)$ . Let  $C$  be the subset of vertices  $v_i \in V(Q)$  such that  $v_i \in C$  if and only if  $w_i \in H$ . Since  $u_i, z_i, w_i$  in  $G$  are associated with  $v_i$  in  $Q$  and out-edges of  $z_i$  in  $G$  represent the neighborhood of  $v_i$  in  $Q$ , we conclude that  $C$  is a clique of size  $c$  in  $Q$ . Hence  $\text{CLIQUE}(c)$  is FTP-reducible to  $\text{MIN-X-Y}(k)$ .  $\square$

**Corollary 8**  $\text{MIN-X-Y}(k)$  is  $W[1]$ -hard.  $\square$

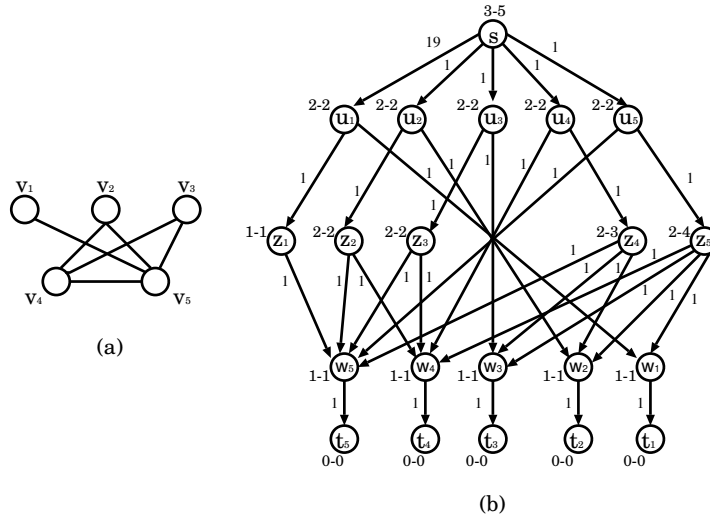

Figure 4: FPT-reduction of graph  $Q$  in (a) to x-y graph  $G$  in (b).

## 4 Conclusions

In this paper we have proved that MIN-AND/OR remains NP-hard even for and/or graphs where edges have weight one, or-vertices have out-degree at most two, and vertices in with in-degree greater than one are within distance at most one of a sink; and that deciding whether there is a solution subtree with weight exactly  $k$  of a given x-y tree is also NP-hard. We also have shown that MIN-AND/OR( $k, r$ ) is in FPT, MIN-AND/OR<sup>0</sup>( $k$ ) is W[2]-hard, and MIN-X-Y( $k$ ) is W[1]-hard.

The question of classifying the parameterized problem MIN-AND/OR( $k$ ) for and/or graphs whose edges have *positive* weights remains open.

## References

- [1] Adelson-Velsky G. M., Gelbukh A. F., Levner, E., A fast scheduling algorithm in AND-OR graphs, *Topics in Applied and Theoretical Mathematics and Computer Science*, WSEAS Press, p. 170-175, 2001.
- [2] Adelson-Velsky G. M., Levner E., Routing information flows in networks: A generalization of Dijkstra's algorithm, *Proceedings of the International Conference "Distributed Computer Communication Networks"*, 1999.

- [3] Barbosa V. C., The combinatorics of resource sharing, in Fialles, M. and Gomes, F., editors, *Models for Parallel and Distributed Computation: Theory, Algorithmic Techniques and Applications*, Kluwer Academic Publishers, The Netherlands, 2002.
- [4] Barnett J. A., Verma T., Intelligent reliability analysis, *10th IEEE Conference on Artificial Intelligence for Applications*, p. 428-433, 1994.
- [5] Cao T., Sanderson, A. C., And/or net representation for robotic task sequence planning, *IEEE Trans. Systems Man Cybernet, Part C: Applications and Reviews*, v. 28, p. 204-218, 1998.
- [6] Corandi R., Westfechtel B., Version models for software configuration management, *ACM Computing Surveys*, v. 30, p. 233-282, 1998.
- [7] DeMello L. S. H., Sanderson A. C., A correct and complete algorithm for the generation of mechanical assembly sequences, *IEEE Trans. Robotics and Automation*, v. 7, p. 228-240, 1991.
- [8] Downey, R., Fellows, M., *Parameterized Complexity*, Springer-Verlag, 1999.
- [9] Flum J., Grohe M., *Parameterized Complexity Theory*, Springer, 2006.
- [10] Gallo G., Longo G., Nguyen S., Pallottino S., Directed hypergraphs and applications, *Discrete Applied Mathematics*, v. 42, p. 177-201, 1993.
- [11] Jiménez P., Torras C., Speeding up interference detection between polyhedra, *IEEE International Conference on Robotics and Automation*, v. 2, p. 1485-1492, 1996.
- [12] Karp R. M., Reducibility among combinatorial problems, in R. E. Miller and J. W. Thatcher, editors, *Complexity of Computer Computations*, Plenum Press, 1972.
- [13] Kumar V., Kanal L. N., Parallel branch-and-bound formulations for and/or tree search, *IEEE Transactions Pattern Analysis and Machine Intelligence*, PAMI-6, p. 768-778, 1984.
- [14] Laber, E. S., A randomized competitive algorithm for evaluating priced and/or trees, *Theoretical Computer Science*, v. 401, n. 1, p. 120-130, 2008.
- [15] Morabito R., Pureza V., A heuristic approach based on dynamic programming and and/or-graph search for the constrained two-dimensional

guillotine cutting problem, *Annals of Operation Research*, v. 179, p. 297-315, 2010.

- [16] Niedermeier, R., *Invitation to Fixed-Parameter Algorithms*, Oxford Lecture Series in Mathematics and Its Applications, Oxford University Press, 2006
- [17] Nilsson N. J., Problem-reduction representations, in Dojny, R. F. and Eakins, M., editors, *Problem Solving Methods in Artificial Intelligence*, McGraw-Hill, 1971.
- [18] Sahni S., Computationally related problems, *SIAM Journal on Computing*, v. 3, n. 4, p. 262-279, 1974.
- [19] Simon R., Lee R. C. T., On the optimal solution of and/or series parallel graphs, *Journal of Association for Computing Machinery*, v. 18, n. 3, p. 354-372, 1971.