

# On Stability Problems of Omega and 3-Disjoint Paths Omega Multi-stage Interconnection Networks

Ravi Rastogi<sup>1</sup>, Nitin<sup>1</sup>, Durg Singh Chauhan<sup>2</sup> and Mahesh Chandra Govil<sup>3</sup>

<sup>1</sup>Department of CSE and IT, Jaypee University of Information Technology,  
Waknaghat, Solan, Himachal Pradesh 173234, India

<sup>2</sup>Uttarakhand Technical University,  
Dehradun, Uttarakhand 241001, India

<sup>3</sup>Malaviya National Institute of Technology  
Jaipur, Rajasthan 302017, India

## Abstract

The research paper emphasizes that the Stable Matching problems are the same as the problems of stable configurations of Multi-stage Interconnection Networks (MIN). We have discussed the Stability Problems of Existing Regular Omega Multi-stage Interconnection Network (OMIN) and Proposed 3-Disjoint Paths Omega Multi-stage Interconnection Network (3DON) using the approaches and solutions provided by the Stable Matching Problem. Specifically, Stable Marriage Problem is used as an example of Stable Matching. On application of the concept of the Stable Marriage over the MINs states that OMIN is highly stable in comparison to 3DON.

## 1. Introduction and Motivation

In a Stable Matching problem, the task is to match a number of persons in pairs, subject to certain preference information. Briefly, each person regards some of the others as acceptable mates and ranks them in order of preference. A matching is unstable if two persons did not match and considered together. The task is to find a stable matching, i.e., one that is acceptable to pairs. The subject of this paper is the Stable Marriage problem in particular, and stable matching problems in general. Gale and Shapley [1] first studied this problem. Gale and Shapley have shown that a stable matching always exists if the problem is a marriage problem, i.e., if the participants can be divided into two sexes, the men and the women, in such a way that the acceptable mates of each person are all of the opposite sex; in fact, both proposed a linear-time algorithm to find such a matching. Irving, in [3], gave a linear-time algorithm for general problem. An introductory treatment of stable matching appears in reference [4]; a comprehensive treatment is reported in reference [2].

This paper explores the relationship between stable matching and Multi-stage Interconnection Networks (MIN) Stability Problem. Mayr and Ashok proved that the Network Stability problem is NP-Complete in general [5–7], but when the network is a MIN, then the stability problem becomes equivalent to stable matching. Specifically, stable marriage problem has been used as an example of stable matching to solve the MINs stability problem. It is concluded that the situation in which the MINs become unstable and proved stable using the stable matching approach. The algorithms have been proposed to solve this problem and provide better solutions when the instances of stable matching have ties or when issues of deceit are involved. It explores the structure of all instances of stable matching similar to the research work presented by Gusfield [8], Irving [9] and Feder [10]. MINs are widely used for broadband switching technology and for multiprocessor systems. Besides this, MINs offers an enthusiastic way of implementing switches used in data communication networks. With the performance requirement of the switches exceeding several terabits/sec and teraflops/sec, it becomes imperative to make them dynamic and fault-tolerant [11–29]. In this paper the stability problem of 16 x 16 Omega Multi-stage Interconnection Network (OMIN) [22] and 16 x 16 3-Disjoint Paths Omega Multi-stage Interconnection Network (3DON) [22] are solved and have been compared with the following Irregular MINs known as Hybrid ZETA Network (HZTN) [24], Quad-tree Network (QTN) [25] and Regular MINs known as Gamma Multi-stage Interconnection Network (GMIN) [22, 23], 3-Disjoint Paths Gamma Multi-stage Interconnection Network (3DGMIN) [22, 23], 3-Disjoint Paths Cyclic Gamma Interconnection Network (3DCGMIN) [23] Augmented Shuffle-exchange Network (ASEN) [26, 27], Augmented Baseline Network (ABN) [28] and Hybrid Cross-Link Network (CLN) [29]. The stability result of HZTN, QTN,

ASEN, ABN and CLN are already evaluated and reported in [24].

The rest of the paper is organized as follows: Section 2 contains introduction of INs, MINs, and stable matching problems. Section 3 provides the algorithms, preference lists, and optimal pairs to solve the stability problems of 16 x 16 OMIN and 16 x 16 3DON. Section 4 presents the results followed by the conclusion.

## 2. Preliminaries and Background

### 2.1 Stable Matching

An instance of stable matching is an instance of stable marriage if the persons divided into two sets, the men and the women, so that the acceptable mates of each person are all of the opposite sex. An instance of stable matching is an instance of Complete Stable Matching if there is an even number of persons and each person is acceptable to everyone else. Similarly, an instance of stable marriage is an instance of complete stable marriage if there are an equal number of men and women and each person is acceptable to every person of the opposite sex. The size of an instance of stable matching is the sum, over all persons  $x$ , of the number of persons acceptable to  $x$ . The most common tasks associated with an instance of stable matching are to determine whether a stable matching exists and to construct one if possible. Other tasks might include counting and enumerating all stable matchings of a given instance.

### 2.2 Multi-stage Interconnection Networks

MINs consist of multiple stages of SEs. Popular among them is a class of regular networks which in their basic form, consist of  $\log_m N$  stages of  $m \times m$  SEs connecting  $N$  input terminals to  $N$  output terminals. Sometimes MINs can also be built using large SEs and correspondingly have less number of stages, with similar properties. There exist many different topologies for MINs, which are characterized by the pattern of the between links between stages.

Multi-stage Interconnection Networks (MINs) [1-10] are used to design a network in which there are several independent paths between two modules being connected which increases the available bandwidth. With the performance requirement of the switches exceeding several terabits/sec and teraflops/sec, it becomes imperative to make them dynamic and fault-tolerant. For high reliability and performance, several methods have been suggested that provide fault-tolerance to MINs [11-23]. The basic idea for fault-tolerance is to provide multiple paths for a source-destination pair, so that

alternate paths can be used in case of a fault in a path. However, to guarantee 1-fault tolerance, a network should have a pair of alternate paths for every source-destination pair, which are Disjoint in nature [23, 24]. Now-a-days applications of MINs are widely used for on-Chip communication. In past number of techniques has been used to increase the reliability and fault-tolerance of MINs, a survey of the fault-tolerance attributes of these networks is found in [1-6]. The modest cost of unique paths MINs makes them attractive for large multiprocessors systems, but their lack of fault-tolerance, is a major drawback. To mitigate this problem, three hardware options are available:

1. Replicate the entire network,
2. Add extra stages,
3. And /or Add chaining links.
4. Rearranging of the connection patterns with the addition or deletion of hardware links.

In order to design 3DON we have used the fourth option.

#### 2.2.1 Network Architecture of 16 x 16 Omega Multi-stage Interconnection Network

A OMIN (Figure 1) is described by the perfect  $k$ -shuffle permutation  $\sigma^k$  for  $0 \leq l \leq n - 1$ . Connection pattern  $C_n$  is selected to be  $\beta_0^k$ . MINs interconnect  $N$  input/output ports using  $k \times k$  switches,  $\log_k N$  switch stages, each with  $N/K$  switches and  $N/(k * (\log_k N))$  total number of switches [1-5]. As the MINs size increases the cost also increases and the reduction in MINs, switch cost comes at the price of performance. The Network has the property of being blocking and the contention is more likely to occur on network links moreover the paths from different sources to different destinations share one or more links.

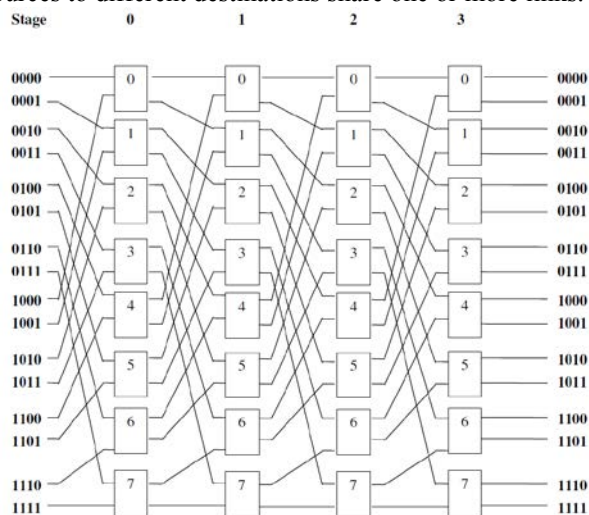

Fig. 1 A 16 x 16 Omega Multi-stage Interconnection Network (OMIN).

### 2.2.2 Proposed Network Architecture of 16 x 16 3-Disjoint Paths Omega Multi-stage Interconnection Network

We have choose “to add an extra stages to the network” in order to improve to convert the omega network into fault-tolerant network called as 3DON. A 3DON (see figure 3.3) of size  $N = 2^n$  is similar to Omega Network, except the source nodes  $2i$  and  $2i + 1$  are combined into one  $2 \times 4$  switch and with an extra stage. The  $2 \times 4$  switches at the  $2i$  stage deliver packets to

1.  $i - 2, i - 1, i + 1$  and  $i + 2$  (where  $i$  is not equal to 0 or  $N - 1$ ),
2.  $i, i + 1$  and  $i + 2$  (where  $i$  is equal to 0),
3.  $i, i - 1$  and  $i - 2$  (where  $i$  is equal to  $N - 1$ ).

Similarly, the destination nodes  $2i$  and  $2i + 1$  are also combined into a  $2 \times 4$  switch. These  $2 \times 4$  switches receive packets from

1.  $i - 2, i - 1, i + 1$  and  $i + 2$  (where  $i$  is not equal to 0 or  $N - 1$ ),
2.  $i, i + 1$ , and  $i + 2$  (where  $i$  is equal to 0),
3.  $i, i - 1$ , and  $i - 2$  (where  $i$  is equal to  $N - 1$ ).

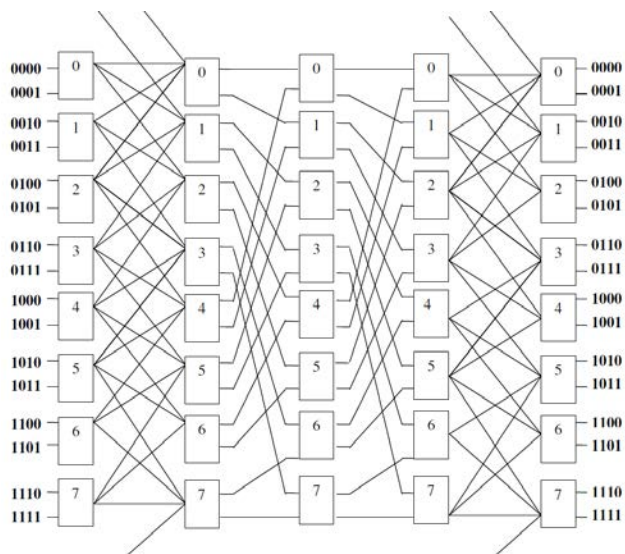

Fig. 2 A 16 x 16 3-Disjoint Paths Omega Multi-stage Interconnection Network (3DON).

## 3. Solving Multi-stage Interconnection Networks Stability Problem using Stable Matching

### 3.1 MINs Stability Problem

MINs provide an easy way through which the information is routed via the specified switches, however it varies greatly with the type of topology that is used and it may be unstable for many instances. The routing mechanisms via

the switches occur through the path-length algorithm upon the basis of which the shortest path to the destination is selected. Unstability in any MIN (regular or irregular) may occur if at any instance, a node fails and no alias path is available for routing through any of the nodes.

The switches are highly independent of each other as such no conjugation occurs amongst them thereby yielding no possible track and leaves the entire network as unstable. As the switches have no dependency, no backtracking mechanism is available thus if the initial nodes as in Figures (5, 11, and 15) fail the path is deadlocked and the entire network becomes unstable. The topology of the network has little significance associated with the instability, as the network is not fault tolerant in case of failure thus instability is bound to occur. The switches are unaware of the next immediate/most optimal path to follow to achieve successful delivery thereby deadlock remains causing instability.

### 3.2 Stable Matching and MINs Stability Problem

As mentioned in the above context due to the instability of the network it becomes less fault-tolerant, which leads to deadlock situation. To tackle this problem a mechanism of stable matching is improvised to prevent failure from occurring. Since at every level  $n = 0, 1, 2, 3$  the switches are aware of their immediate neighbors, chooses the best fit on the basis of the preference list created using the path-length approach from the preference matrix of the specific MIN.

With the application of the stable matching approach even in case of the path failure the conjugate pairs are active based on preference path length and the desired path is accepted. The same is carried forward for the backtracking approach thus no path is failed at every segment hence even in case of failures of first SE of each segment there is an alias path available so that the destination is reached. For example:

Case 1: Refer Figure (15). Now consider that you have send data from SE 1 to SE 25 and if SE 9 fails then the request either jumps to SE 10 (and follow the path = SE 1–SE 10–SE 18–SE 25 ) or it jumps to SE 5 (and follow the path = SE 1–SE 5–SE 12–SE 18–SE 25 ) using chaining link and reaches the destination using the path-length of 3 hence successfully transferring data that can be seen from the preference lists of the switches provided in Figure (13) resulting in keeping the entire network stable (as no congestion occurs).

### 3.3 Assumptions

Before writing the required algorithm, here are some assumptions that have to be taken care of. The

assumptions while implementing the stable matching algorithm as following:

1. Priority of the Traversal of the Paths: The algorithm that is employed in the calculation of paths is based on the concept of path length algorithm. Priority is given to the node by means of which the destination can be reached in minimum time and cost in comparison to any other node in the entire circuit.
2. Neglecting pairs of the level with minimum number of nodes: Since at the level with number of nodes the amount of inflowing paths is very high thereby the probability of it selecting the most optimized pair is very low, as it has multiple out flowing paths to the destination of relatively similar path lengths within the circuit and hence, get neglected.

The sole purpose of choosing the assumptions is the fact that without them the stability of the network cannot be proved. There are a large number of observable features present in the network that have to be neglected to prove the above cause. Assumptions have been included to enhance our effort to provide an efficient approach in proving the network to be stable. In addition, by assuming them, it helps us to decide the broad criteria of defining the constraints under which the network is going to act effectively and the concept of stable matching augmented well. The fundamental approach of assuming these conditions is to provide us with an initial approach that laid emphasis on the key aspect of stability using stable matching algorithm. Furthermore, if these assumptions are not considered then it will leads to NP-Completeness problem.

### 3.3.1 NP-Completeness

A problem is called NP (nondeterministic polynomial) if its solution (if one exists) can be guessed and verified in polynomial time, nondeterministic means that no particular rule is followed to make the guess. Thus, finding an efficient algorithm for any NP-Complete problem implies that an efficient algorithm can be found for all such problems, since any problem belonging to this class can be recast into any other member of the class. As far as the above solution is concerned the problem of NP-Completeness arises from the fact that the stability of the network can be rendered from the stable matching approach in a polynomial time solution hence the problem is solved. The solution of the optimal pairs of all the networks as per the algorithm is given above and is produced assuming into consideration of all the assumptions otherwise the solution fails.

Applying by the concept of stable matching, it will render us with an exact solution to the above problem in a defined polynomial time expression.

### 3.4 Algorithm for Deriving Preference Lists from the MINs

The algorithm to generate the preference lists of the MIN is explained here. This algorithm is on the similar lines of the Gale-Shapley Algorithm.

#### Algorithm: PREFERENCE\_LISTS

Inputs: Priority of SE/Nodes based on shortest path concept of reaching the goal.

Output: Provides a Priority Preference Lists from which the Optimal Pairs are selected.

Precondition: Each list has a collection of only those SE that in turn are always connected to.

Postcondition: The Optimized Preference lists are generated.

1. Stable  $\leftarrow$  TRUE (No condition of Tie occurs with two SE having the same Priority Pairs)
2. FOR each Switch SE 1
3. FOR each Switch SE 2
4. IF ((SE 1 prefers SE 2 to its existing pair as it has a shorter path length to reach Destination SE and both are connected)) and ((SE 2 prefers SE 1 to its existing pair as it has a shorter path length to reach Destination SE and both are connected))
5. THEN the Switches SE 1 and SE 2 exist mutually in their list.
6. ELSE IF (If SE 1 and SE 2 have Tie for their list elements order them both in their lists)
7. ELSE (If SE 1 and SE 2 do not have a path amongst each other)
8. WRITE "SE 1 and SE 2 do not have a Stable Pair"
9. Stable  $\leftarrow$  FALSE
10. END IF
11. END IF
12. END FOR
13. END FOR
14. WRITE "The Preference Lists is generated"
15. EXIT

Complexity: The run time complexity of the Algorithm: PREFERENCE\_LISTS is  $O(n^2)$ .

#### Proof of Complexity or Correctness:

Let SE 1 = SE 2 =  $n$

For lines from #2 to 13 the Time =  $n \times n$  (time taken in generating the MINs preference lists) =  $n^2 \times$  Constant

Therefore, Complexity in Big (O) notation is  $O(n^2)$ .

### 3.5 Reduction of the Ties in Irregular and Regular MINs

The reduction of the ties in the irregular and regular networks is discussed here. After deriving the preference lists of an irregular and regular network that has been created based on the patterns described in the previous section a basic aspect that has borne in mind is that while creating the preference list there are a large number of cases where ties occurs, which means for a specific SE that has to be resolved as it will result in congestion as two pairs have the same pair of optimal switches defined in the

preference list. Thus in such a case priority is set in a such a way that the switch next in the list is tested for priority with all other switches and case of resolution of this clause it is allocated to the specific switch/ node and if this is not acceptable the procedure is carried on with other switches in the list and vice versa.

### 3.6 Deriving Optimal Pairs from MINs Preference Lists

The algorithm for a solution to a stable marriage instance in MIN is based on a sequence of “proposals” from one switch to the other based on shortest path length to reach the destination. Each switch proposes, in order, to the nodes (switches) on his preference list, pausing when a node agrees to consider his proposal, but continuing if a proposal is rejected either immediately or subsequently. When another node receives a proposal, it rejects it if the specified node already holds a better proposal, but otherwise agrees to hold it for consideration, simultaneously rejecting any poorer proposal that the node may currently hold i.e. the preference is given to the node which is higher or first in the priority list than any other nodes also specified later in its specific list.

It is not difficult to show, as in that the sequence of proposals so specified ends with every switch holding a unique proposal, and that the proposals held constitute a stable matching. The Two fundamental implications of this initial proposal sequence are:

1. If SE 1 proposes to SE 2, then there is no stable matching in which SE 1 has a better partner than SE 2.
2. If SE 2 receives a proposal from SE 1, then there is no stable matching in which SE 2 has a worse partner than SE 1.

These observations suggest us explicitly to remove SE 1 from SE 2’s list and SE 2 from SE 1’s list. If SE 1 receives a proposal from some node that is better in priority than SE 2 then the resulting lists or pairs as the shortlists for the given problem instance is referred.

#### Algorithm: SELECTING\_STABLE\_PAIRS

Inputs: Preference lists of SE.

Output: A matching consisting of list of engaged pairs.

Precondition: Each list includes the connection of one SE with all the other.

Postcondition: A matching is produced which is stable for each SE.

1. FOR each Switch SE
2. Engaged (SE)  $\leftarrow$  FALSE
3. END FOR
4. WHILE there is a SE which is not engaged
5. FOR each Switch SE y
6. IF Switch SE y is not yet engaged
7. THEN SE x  $\leftarrow$  highest on SE y list, which is not yet engaged
8. ADD (SE y, SE x) to the Stable Pair List

9. END IF
10. END FOR
11. END WHILE
12. Write “List of Optimal (Stable) Pairs”

Complexity: The run time complexity of the Algorithm: SELECTING\_STABLE\_PAIRS is  $O(n)$ .

#### Proof of Complexity or Correctness:

Let time of adding (SE y, SE x) to stable pair list =  $t_1$

Number of SEs =  $n$

Hence Time =  $n \times t_1$

Therefore, Time Complexity in Big (O) notation is  $O(n)$

### 3.7 Application of Stable Matching Approaches to Solve MINs Stability Problems

#### 3.7.1 A 16 x 16 OMIN

It is know that the OMIN is regular networks and there is no need to give the path length algorithm, as the path length remains constant on all the routes (may be primary, secondary, or express).

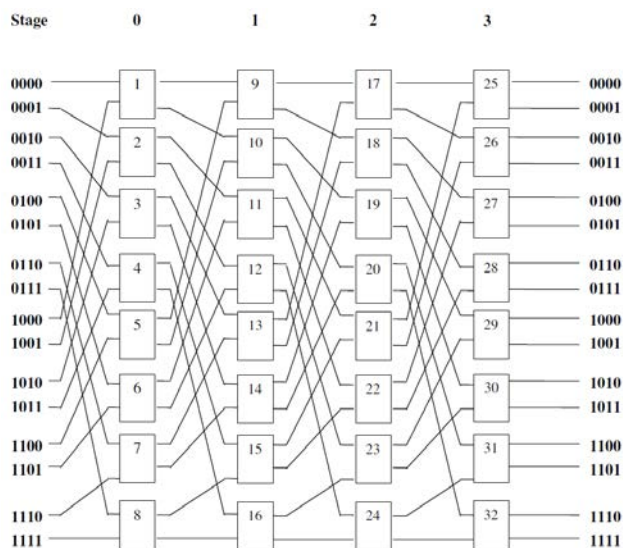

Fig. 3 A 16 x 16 OMIN. Here SEs are renumbered to solve the stability problem.

#### 3.7.1.1 Preference Lists

Refer algorithm explained in Section (3.4) for deriving preference lists for the OMIN. The SEs in Figure (1) are renumbered and put up again in Figure (3). Figure (4), shows the preference lists.

SE 1 9 10 17 18 19 20 25 26 27 28 29 30 31 32  
 SE 2 11 12 21 22 23 24 25 26 27 28 29 30 31 32  
 SE 3 13 14 17 18 19 20 25 26 27 28 29 30 31 32  
 SE 4 15 16 21 22 23 24 25 26 27 28 29 30 31 32  
 SE 5 9 10 17 18 19 20 25 26 27 28 29 30 31 32  
 SE 6 11 12 21 22 23 24 25 26 27 28 29 30 31 32  
 SE 7 13 14 17 18 19 20 25 26 27 28 29 30 31 32  
 SE 8 16 15 24 23 21 22 32 31 29 30 25 26 27 28  
 SE 9 17 18 25 26 27 28  
 SE 10 19 20 29 30 31 32  
 SE 11 21 22 25 26 27 28  
 SE 12 23 24 29 30 31 32  
 SE 13 17 18 25 26 27 28  
 SE 14 19 20 29 30 31 32  
 SE 15 21 22 25 26 27 28  
 SE 16 24 23 32 31 29 30  
 SE 17 25 26  
 SE 18 27 28  
 SE 19 29 30  
 SE 20 31 32  
 SE 21 25 26  
 SE 22 27 28  
 SE 23 29 30  
 SE 24 32 31

Fig. 4 The complete preference lists of the OMIN.

### 3.7.1.2 Reduction of the Ties

Refer procedure explained in Section (3.5). The same is used here to derive the optimal pairs for the OMIN. See Figure (4) the preference list for the SE 1 and SE 5 stands as:

SE 1 9 10 17 18 19 20 25 26 27 28 29 30 31 32  
 SE 5 9 10 17 18 19 20 25 26 27 28 29 30 31 32

Both the above cases have been rendered in such a method that SE 9 comes in priority 1 of them as such both can form the optimal pairs. Therefore to resolve the above conflict it is assumed that the SE 1 lays more emphasis upon considering the switch SE 9 first as it appears before hence it is allocated to it and for switch SE 5, SE 10 comes

in the next order of preference and it is compared to all other members in the preference list in which SE 5 seems to have more priority over the switch SE 10 than any other switch hence is allocated to it. Thereby the optimal pairs are as follows:

SE 1 --- SE 9  
 SE 5 --- SE 10

The same procedure can be and is followed for all such cases in case such a collision occurs and a Tie for priority of switches occurs.

### 3.7.1.3 Deriving Optimal Pairs from the Preference Lists

Refer procedure explained in Section (3.6). The same is used here to derive the optimal pairs for OMIN. See Figure (4), the preference lists of OMIN or the switch SE 4 stands as:

SE 4 15 16 21 22 23 24 25 26 27 28 29 30 31 32

SE 4 has highest priority been set to SE 15 as such appears first in the priority list and next priority has been set to SE 16 as such appears second and SE 21 as third and so on.

As it can be seen in Figure (4), that SE 8 has specified as:

SE 8 16 15 24 23 21 22 32 31 29 30 25 26 27 28

Thus the priority of SE 16 is more on the list of SE 8 thus both will exist as a stable matched pair and the set can be stable thus the above list reduced by eliminating the corresponding SE 16 from the list of SE 4 as someone else (SE 8) holds a better proposal for the SE 16 to follow the path and reach to its destination in minimum path length.

SE 4 15 --- 21 22 23 24 25 26 27 28 29 30 31 32  
 and it becomes;

SE 4 15 21 22 23 24 25 26 27 28 29 30 31 32

Similarly, the nodes SE 21, SE 23, SE 24, SE 25, SE 27, SE 29, SE 31 and SE 32 occur higher in the priority list of switches SE 11, SE 12, SE 16, SE 17, SE 18, SE 23, SE 20 and SE 24 thereby eliminating the above eight switches from the list of SE 4 and similarly the final list of optimal set is:

SE 4 15 22 26 28 30

Thus, the final pair becomes SE 4 and SE 15, which is stable in nature. Based on this assumption and analysis the following Figure (5) {which shows all the optimal pairs} has been compiled.

- (1,9), (2,11), (3,13), (4,15),
- (5,10), (6,12), (7,14), (8,16),
- (9, 17), (10,19), (11,21), (12, 23),
- (13,18), (14,20), (15,22), (16,24),
- (17,25), (18,27), (19,29), (20,31)
- (21,26), (22,28), (23,30) and (24,32)

Fig. 5 The optimal pairs, which have been short-listed from the OMIN preference lists.

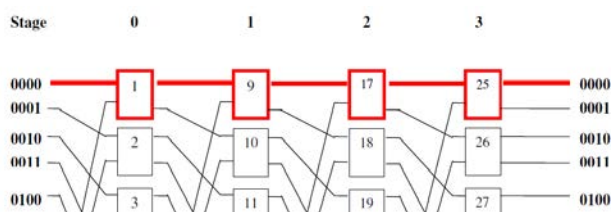

Fig. 6 The partial cut way part of OMIN.

Example 1. See Figure (6) and Table (1) for all possible routes and path-lengths. In this particular example a request is routed from source 0 to destination 0 i.e. source 0000 to destination 0000.

Table 1: The routing table of OMIN.

<i>Routes</i>	<i>Path-length</i>
SE 1 - SE 9 - SE 17 - SE 25	3

Explanation: In this example (Table (1)), all the possible paths from the source to destination are listed. To route a request from a given source to given destination can have possible routes and possible path-lengths. In the particular example, there is only one path from one source to destination i.e. SE 1 - SE 9 - SE 17 - SE 25. The respective path-length at all the paths throughout the circuit is 3 only.

Since OMIN is a regular MIN, therefore it is always have a constant path-length on all the routes.

### 3.7.2 A 16 x 16 3DON

It is know that the 3DON is regular networks and there is no need to give the path length algorithm, as the path length remains constant on all the routes (may be primary, secondary, or express).

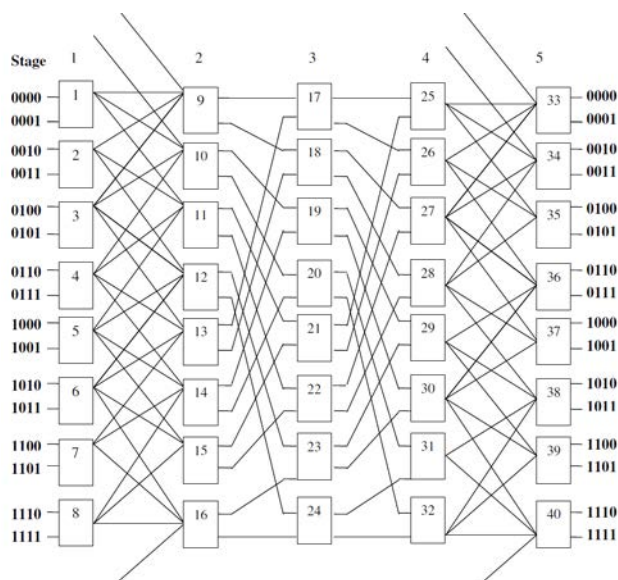

Fig. 7 A 16 x 16 3DON. Here SEs are renumbered to solve the stability problem.

#### 3.7.2.1 Preference Lists

Refer algorithm explained in Section (3.4) for deriving preference lists for the 3DON. The SEs in Figure (2) are renumbered and put up again in Figure (7). Figure (8), shows the preference lists having Ties. All Ties have been solved for 3DON.

SE 1 9 10 11 17 18 19 20 21 22 25 26 27 28 29 30 31 32 25 26 27 28 33 34 35 33 35 36 33 34 36 37 34 35 37 38 36 38 39 36 37 39 40 38 40 40 38 39

SE 2 9 11 12 17 18 21 22 23 24 25 26 27 28 25 26 27 28 29 30 32 31 33 34 35 33 35 36 33 34 36 37 34 35 37 38 36 38 39 36 37 39 40 38 39 40 38 40

SE 3 9 10 12 13 17 18 19 20 23 24 17 18 25 26 27 28 29 30 32 31 29 30 32 31 33 34 35 33 35 36 33 34 36 37 34 35 37 38 36 38 39 36 37 39 40 38 39 40 38 40

SE 4 10 11 13 14 19 20 21 22 17 18 19 20 29 30 32 31 25 26 27 28 25 26 27 28 36 38 39 36 37 39 40 38 39 40 38 40 33 34 35 33 35 36 33 34 36 37 34 35 37 38

SE 5 11 12 14 15 21 22 23 24 19 20 21 22 25 26 27 28 29 30 32 31 29 30 32 31 33 34 35 33 35 36 33 34 36 37 34 35 37 38 36 38 39 36 37 39 40 387 39 40 38 40

SE 6 12 13 15 16 23 24 17 18 21 22 23 24 29 30 32 31 25 26 27 28 25 26 27 28 36 38 39 36 37 39 40 38 39 40 38 40 33 34 35 33 35 36 33 34 36 37 34 35 37 38

SE 7 13 14 16 17 18 19 20 23 24 25 26 27 28 29 30 32 31 29 30 32 31 33 34 35 33 35 36 33 34 36 37 34 35 37 38 36 38 39 36 37 39 40 38 39 40 38 40

SE 8 16 14 15 24 23 19 20 21 22 32 31 29 30 29 30 31 32 25 26 27 28 40 38 39 38 40 36 38 39 36 37 39 40 36 38 39 33 34 35 33 35 36 33 34 36 37 34 35 37 38

SE 9 17 18 25 26 27 28 33 34 35 33 35 36 33 34 36 37 34 35 37 38

SE 10 19 20 29 30 32 31 36 38 39 36 37 39 40 38 40 38 39 40

SE 11 21 22 25 26 27 28 33 34 35 33 35 36 33 34 36 37 34 35 37 38

SE 12 23 24 29 30 32 31 36 38 39 36 37 39 40 38 39 40 38 40

SE 13 17 18 25 26 27 28 33 34 35 33 35 36 33 34 36 37 34 35 37 38

SE 14 19 20 29 30 32 31 36 38 39 36 37 39 40 38 40 38 39 40

SE 15 21 22 25 26 27 28 33 34 35 33 35 36 33 34 36 37 34 35 37 38

SE 16 24 23 32 31 29 30 40 38 39 38 40 36 38 39 36 37 39 40

SE 17 25 26 33 34 35 33 35 36

SE 18 27 28 33 34 36 37 34 35 37 38

SE 19 29 30 36 38 39 36 37 39 40

SE 20 31 32 38 40 40 38 39

SE 21 25 26 33 34 35 33 35 36

SE 22 27 28 33 34 36 37 34 35 37 38

SE 23 29 30 36 38 39 36 37 39 40

SE 24 32 31 40 38 39 38 40

SE 25 33 34 35

SE 26 33 35 36

SE 27 33 34 36 37

SE 28 34 35 37 38

SE 29 36 38 39

SE 30 36 37 39 40

SE 31 38 40

SE 32 40 38 39

Fig. 8 The complete preference lists of the 3DON.



### 3.7.2.2 Reduction of the Ties

Refer procedure explained in Section (3.5). The same is used here to derive the optimal pairs for the 3DON. See Figure (8) the preference list for the SE 1 and SE 3 stands as:

SE 1 9 10 11 17 18 19 20 21 22 25 26 27 28 29 30 31 32 25 26 27 28 33 34 35  
 33 35 36 33 34 36 37 34 35 37 38 36 38 39 36 37 39 40 38 40 38 39

SE 3 9 10 12 13 17 18 19 20 23 24 17 18 25 26 27 28 29 30 32 31 29 30 32 31 33  
 34 35 33 35 36 33 34 36 37 34 35 37 38 36 38 39 36 37 39 40 38 39 40 38 40

Both the above cases have been rendered in such a method that SE 9 comes in priority 1 of them as such both can form the optimal pairs. Therefore to resolve the above conflict it is assumed that the SE 1 lays more emphasis upon considering the switch SE 9 first as it appears before hence it is allocated to it and for switch SE 3, SE 10 comes in the next order of preference and it is compared to all other members in the preference list in which SE 3 seems to have more priority over the switch SE 10 than any other switch hence is allocated to it. Thereby the optimal pairs are as follows:

SE 1 --- SE 9  
 SE 3 --- SE 10

The same procedure can be and is followed for all such cases in case such a collision occurs and a Tie for priority of switches occurs.

### 3.7.2.3 Deriving Optimal Pairs from the Preference Lists

Refer procedure explained in Section (3.6). The same is used here to derive the optimal pairs for the 3DON. See Figure (8), the preference lists of 3DON for the switch SE 20 stands as:

SE 20 31 32 38 40 40 38 39

SE 20 has highest priority been set to SE 31 as such appears first in the priority list and next priority has been set to SE 32 as such appears second and SE 38 as third and so on.

As it can be seen in Figure (8), that SE 24 has specified as:

SE 24 32 31 40 38 39 38 40

Thus the priority of SE 32 is more on the list of SE 24 thus both will exist as a stable matched pair and the set can be stable thus the above list reduced by eliminating the corresponding SE 32 from the list of SE 20 as someone

else (SE 24) holds a better proposal for the SE 32 to follow the path and reach to its destination in minimum path length.

SE 20 31 -- 38 40 40 38 39 and it becomes;  
 SE 20 31 38 40 40 38 39

Similarly, the nodes SE 38 and SE 40 occur higher in the priority list of switches SE 31 and SE 32 thereby eliminating the two switches from the list of SE 20 and similarly the final list of optimal set is:

SE 20 31 39

Thus, the final pair becomes SE 20 and SE 31, which is stable in nature. Based on this assumption and analysis the following Figure (9) {which shows all the optimal pairs} has been compiled.

- (1, 9), (2, 11), (3, 10), (4, 13), (5, 12),
- (6, 15), (7, 13), (8, 16), (9, 17), (10, 19),
- (11, 21), (12, 23), (13, 18), (14, 20), (15, 22),
- (16, 24), (17, 25), (18, 27), (19, 29), (20, 31),
- (21, 26), (22, 28), (23, 30), (24, 32), (25, 33),
- (26, 35), (27, 34), (28, 37), (29, 36) and (30, 39),
- (31, 38) and (32, 40)

Fig. 9 The optimal pairs, which have been short-listed from the 3DON preference lists.

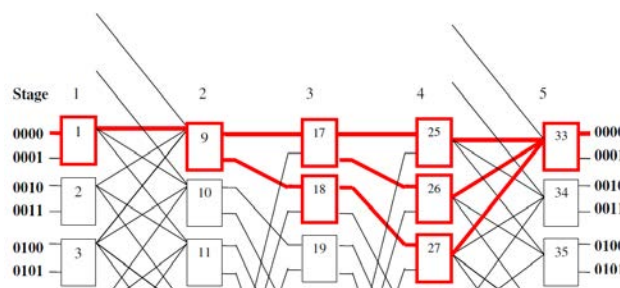

Fig. 10 The partial cut way part of 3DON.

Example 2. See Figure (10) and Table (2) for all possible routes and path-lengths. In this particular example a request is routed from source 0 to destination 0 i.e. source 0000 to destination 0000.

Table 2: The routing table of 3DON.

<i>Routes</i>	<i>Path-length</i>
SE 1 - SE 9 - SE 17 - SE 25 - SE 33	4
SE 1 - SE 9 - SE 17 - SE 26 - SE 33	4

SE 1 - SE 9 - SE 18 - SE 27 - SE 33

4

Explanation: In this example (Table (2)), all the possible paths from the source to destination are listed. To route a request from a given source to given destination can have possible routes and possible path-lengths. In the particular example, there are three paths from one source to destination. The first path (SE 1 - SE 9 - SE 17 - SE 25 - SE 33) is termed as the primary path, the path (SE 1 - SE 9 - SE 17 - SE 26 - SE 33) is termed as the secondary path and (SE 1 - SE 9 - SE 18 - SE 27 - SE 33) is used, when the primary and secondary path is busy. The respective path-length at all the paths mentioned is 4 only. Since 3DON is a regular MIN, therefore it is always have a constant path-length on all the routes.

### 3.8 Comparisons

Based on the analysis of Sections (3.1–3.7) the comparison chart have been made and shown in Table (3) and Figure (11). It is depicted that the regular ASEN, ABN, CLN and 3DCGMIN are highly stable in comparison to the irregular HZTN, QTN and regular DGMIN as the neglected pairs (those who are not able to find any stable match) are 0 in their case. Therefore, regular MINs are highly stable according to the stable matching algorithm.

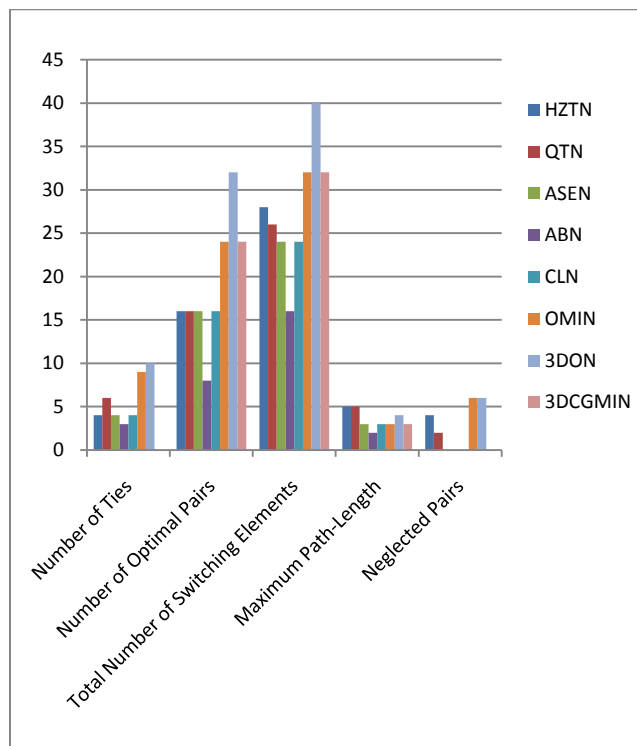

Fig. 11 The comparison graph of different MINs based on their stability.

Table 3: The comparison of 16 x 16 different MINs based on their stability.

<i>MINs</i>	<i>No. of Ties</i>	<i>No. of OPs/Tot al No. of SEs</i>	<i>Maxi mum PL</i>	<i>Negl ected Pairs</i>	<i>MIN Status</i>
HZTN	4	16/28	5	4	Low Stable
QTN	6	16/26	5	2	Intermedi ate Stable
ASEN	4	16/24	3	0	Highly Stable
ABN	3	8/16	2	0	Highly Stable
CLN	4	16/24	3	0	Highly Stable
GMIN	0	20/28	3	0	Highly Stable
3DGMIN	3	20/28	3	2	Intermedi ate Stable
3DCGMIN	0	24/32	3	0	Highly Stable
OMIN	9	24/32	3	6	Low Stable
3DON	10	32/40	4	6	Low Stable

## 4. Conclusion

This paper explores the relationship between stable matching and MINs stability problem. Specifically stable marriage problem is used as example of stable matching to solve the MINs stability problem. The situations in which the fault-tolerant irregular and regular MINs become unstable have been shown. To counter this problem the appropriate algorithm, procedures, and methods have been designed using the concept of stable marriage. The ties problem of the optimal pairs has been solved. The comparison of the MINs based upon their stability shows that the ASEN, ABN, CLN, GMIN, 3DCGMIN are highly stable in comparison to HZTN, QTN, OMIN, 3DON, DGMIN. However, on comparing the irregular and regular MINs in totality upon their stability the regular MINs comes out to be more stable than the irregular MINs.

## References

- [1] D. Gale, L.S. Shapley, College admissions and the stability of marriage, *The American Mathematical Monthly* 69, pp. 9–15, 1962.
- [2] R.W. Irving, An efficient algorithm for the stable roommates problem, *Journal of Algorithms* 6, pp. 577–595, 1985.
- [3] G. Polya, R.E. Tarjan, D.R. Woods, *Notes on introductory combinatorics*, Birkhauser Verlag, Boston, MA, 1983.
- [4] D. Gusfield, R.W. Irving, *The stable marriage problem: structure and algorithms*, The MIT Press, Cambridge, MA, 1989.
- [5] E.W. Mayr, A. Subramanian, The complexity of circuit value and network stability, In *Proceedings of 4th Annual Conference on Structure in Complexity Theory*, pp. 114–123, 1989.

- [6] A. Subramanian, A new approach to stable matching problems, *SIAM Journal of Computing* 23 (4), pp. 671–700, 1994.
- [7] A. Subramanian, The computational complexity of the circuit value and network stability problems, Doctoral Thesis, Department of Computer Science, Stanford University, Stanford, 1990.
- [8] C.W. Chen, Design schemes of dynamic rerouting networks with destination tag routing for tolerating faults and preventing collisions, *The Journal of Supercomputing* 38 (3), pp. 307–326, 2006.
- [9] H.J. Siegal, D.R. Jose, A.B. Fortes, Destination tag routing techniques based on a state model for the IADM network, *IEEE Transaction on Computers* 41 (3), pp. 274–285, 1992.
- [10] T.Y. Feng, A survey of interconnection networks, *IEEE Computer* 14, pp. 12–27, 1981.
- [11] G.B. Adams III, D.P. Agrawal, H.J. Siegel, A survey and comparison of fault-tolerant multi-stage interconnection networks, *IEEE Computer* 20, pp. 14–27, 1987.
- [12] W.J. Dally, Scalable switching fabrics for internet routers, White paper, Avici Systems Incorporation, 2001.
- [13] L.N. Bhuyan, Special issue of interconnection networks, *IEEE Computer* 20 (6), 1987.
- [14] H.J. Siegel, Interconnection network for large scale parallel processing: theory and case studies, McGraw Hill, ISBN 0-07-057561-4, 1990.
- [15] K. Hwang, Advanced computer architecture: parallelism, scalability, programmability, Tata McGraw-Hill, India, ISBN 0-07-053070-X, 2000.
- [16] J. Duato, S. Yalamanchili, L.M. Ni, Interconnection networks: an engineering approach, Morgan Kaufmann, ISBN 1-55860-852-4, 2003.
- [17] W. Dally, B. Towles, Principles and practices of interconnection networks, Morgan Kaufmann, San Francisco, ISBN 978-0-12-200751-4, 2004.
- [18] Nitin, S. Garhwal, N. Srivastava, Designing a fault-tolerant fully-chained combining switches multi-stage interconnection network with disjoint paths, *The Journal of Supercomputing* 55 (3), DOI 10.1007/s11227-009-0336-z, pp. 400–431, 2009.
- [19] Nitin, D.S. Chauhan, Comparative analysis of traffic patterns on k-ary n-tree using adaptive algorithms based on burton normal form, *Journal of Supercomputing*, DOI: 10.1007/s11227-010-0454-7, pp. 1–20, 2010.
- [20] Nitin, V.K. Sehgal, P.K. Bansal, On MTTF analysis of a fault-tolerant hybrid MINs, *WSEAS Transactions on Computer Research* 2 (2), ISSN 1991-8755, pp. 130–138, 2007.
- [21] Nitin, Component level reliability analysis of fault-tolerant hybrid MINs, *WSEAS Transactions on Computers* 5 (9), ISSN 1109-2750, pp. 1851–1859, 2006.
- [22] R. Rastogi, Nitin, D.S. Chauhan, 3-Disjoint paths fault-tolerant omega multi-stage interconnection network with reachable sets and coloring scheme, In Proceedings of 13th IEEE International conference on Computer Modeling and Simulation (IEEE UKSim), Emmanuel College, Cambridge, UK, pp. 551–556, 2011.
- [23] M. Borkar and Nitin, 3D-CGIN: A 3 Disjoint Paths CGIN with Alternate Source, Proceedings of the 1st International Conference on Advances in Computing and Communications (ACC), Lecture Notes in Computer Science (LNCS), Springer-Verlag, ISSN: 1865:0929, pp. 25-36.
- [24] Nitin, A. Subramanian, Efficient algorithms to solve dynamic MINs stability problems using stable matching with complete TIES, *Journal of Discrete Algorithms* 6 (3), pp. 353–380, 2008.
- [25] P.K. Bansal, K. Singh, R.C. Joshi, Routing and path length algorithm for a cost-effective four-tree multi-stage interconnection network, *International Journal of Electronics* 73 (1) pp. 107–115, 1992.
- [26] V.P. Kumar, S.M. Reddy, Design and analysis of fault-tolerant multistage interconnection networks with low link complexity, In Proceedings of 12th International Symposium on Computer Architecture, pp. 376–386, 1995.
- [27] V.P. Kumar, S.M. Reddy, Augmented shuffle-exchange multistage interconnection networks, *IEEE Computer*, pp. 30–40, 1987.
- [28] P.K. Bansal, R.C. Joshi, K. Singh, On a fault-tolerant multistage interconnection network, *Journal of Computers and Electrical Engineering*, Elsevier Sciences 20 (4), pp. 335–345, 1994.
- [29] S.C. Kothari, G.M. Prabhu, R. Roberts, Multipath network with cross link, *Journal of Parallel and Distributed Computing* 5 (2), pp. 185–193, 1998.

**Ravi Rastogi** is a PhD research scholar at Uttarakhand Technical University and currently working as a Senior Lecturer in the Department of Computer Science & Engineering and Information & Communication Technology, Jaypee University of Information Technology, Waknaghat, Solan-173234, Himachal Pradesh, India. He has published more than 10 research papers in the International refereed Journals and conferences.

**Nitin** is Ex. Distinguished Adjunct Professor of Computer Science, University of Nebraska, Omaha, USA. Currently he is working as an Associate Professor in the Department of Computer Science & Engineering and Information & Communication Technology, Jaypee University of Information Technology, Waknaghat, Solan, Himachal Pradesh, India. He has published more than 80 research papers in the reputed International refereed Journals and Conferences.

**Durg Singh Chauhan** is PhD from IIT Delhi and Postdoc from University of Maryland. Currently working as Vice Chancellor of Uttarakhand Technical University, Dehradun since 2009, Uttarakhand, India. He has published more than 125 research papers in the reputed International refereed Journals and Conferences.

**Mahesh Chandra Govil** is M.Tech. and PhD from IIT Roorkee and Currently working as a Professor in the Department of Computer Science & Engineering at Malaviya Institute of Technology, Jaipur, Rajasthan, India. He has published more than 50 research papers in the refereed Journals and conferences.