

# MANAGING KEY MULTICASTING THROUGH ORTHOGONAL SYSTEMS

JOSÉ ANTONIO ALVAREZ-BERMEJO, JUAN ANTONIO LOPEZ-RAMOS, JOACHIM ROSENTHAL,  
AND DAVIDE SCHIPANI

**ABSTRACT.** In this paper we propose a new protocol to manage multicast key distribution. The protocol is based on the use of orthogonal systems in vector spaces. The main advantage in comparison to other existing multicast key management protocols is that the length and the number of the messages which have to be sent are considerably smaller. This makes the protocol especially attractive when the number of legitimate receivers is large.

**Keywords:** Multicast key management, data transmission security

## 1. INTRODUCTION

Traditional security measures are mainly applicable to a unicast environment, i.e. communications take place between two single parties. For instance, data confidentiality, one of the most important features in network security, can be offered in this environment by means of a pair of keys. However there exist many different situations where the usual secure unicast protocols cannot be used, mainly due to the nature of the information to be transmitted. This usually happens when trying to deliver data from a sender to multiple receivers, especially when a huge amount of data needs to be delivered very quickly. One of the most efficient ways to do this is the so-called multicast. In a multicast protocol a certain group of people receives the information and this group is usually highly dynamic. In a typical situation users join and leave the group constantly ([11]).

There are a number of exciting multimedia applications that make good use of multicast capability, such as stock quote services, video-conferencing, pay-per-view TV, Internet radio, and so on. Many of the aforementioned multicast applications require security in data transmission, i.e., data can only be accessed or exchanged among an exclusive group of users. In the Pay-TV system, for example, the service providers employ Conditional Access System (CAS) to avoid unauthorized accessing of their video/audio streams, and only allow access to services based on payment.

The natural approach to establish secure multicast communications is to agree on one or several symmetric encryption keys in order to encrypt messages. However, the key, or keys, must be renewed periodically to prevent outer or inner attacks. Depending on how key distribution and management are carried out, secure multicast schemes are divided into centralized and distributed schemes. Centralized schemes depend directly on a single entity to distribute every cryptographic key. A typical scenario is an IPTV or P2PTV platform, in which clients receive a TV signal from a Content Server via Internet. Distributed schemes are able to manage higher number of audiences but, on the other hand, key management involves other problems that make them

---

*Date:* December 31, 2014.

The Research was supported in part by the Swiss National Science Foundation under grant No. 149716. First author is partially supported by Spanish Ministry of Science and Innovation (TIN2008-01117), and Junta de Andalucía (P08-TIC-3518). Second author is partially supported by by Spanish Ministry of Science and Innovation (TEC2009-13763-C02-02) and Junta de Andalucía (FQM0211).

more complex ([11]). A big issue concerns security: in a centralized system there is just one server to secure, while in the distributed one security efforts have to be multiplied. Our aim in this paper is to introduce a novel protocol applicable for centralized multicast that is shown to be secure, efficient and scalable.

In the following lines we recall some centralized schemes for key management, although the reader can find a recent survey on secure multicast in [18]. A very well-known protocol is *Hierarchical Tree Approach* (HTA) [15]. It uses a logical tree arrangement of the users in order to facilitate key distribution. The benefit of this idea is that the storage requirement for each client and the number of transmissions required for key renewal are both logarithmic in the number of members. Other key tree approaches and extensions are LKH [17], LKH++ [3], OFT [13] or ELK [10].

In [2] the so-called *Secure Lock* protocol is introduced. The authors approach the problem in a computational manner and make use of the Chinese Remainder Theorem instead of a tree arrangement. Users are distributed into groups, that in the case of PayTV could be represented by those subscribers with the same Pay-Per-Channels (PPC) or Pay-Per-View (PPV) options. The PPC and PPV programs should be encrypted previously to their distribution and there is only a content server and a key server (that might be different or not). Its main drawback is the large computational cost required at the key server side on each rekeying operation: the length of the rekeying messages and the computing time needed becomes quickly problematic as the number of members in one of the PPC or PPV groups grows [8].

In [12], a divide-and-conquer extension of the Secure Lock is proposed. It combines the Hierarchical Tree Approach and the Secure Lock: members are arranged in a HTA fashion, but the Secure Lock is used to refresh keys on each tree level. Therefore, the number of computations required by the Secure Lock is reduced.

Another computational approach with the same distribution by groups of users and a unique key server is introduced in [7] with the particular application on Pay-TV but extendable to any other secure multicast application. The idea is to use polynomials over a finite field interpolating hashes of secret values belonging to the authorized users. The main drawbacks are that the hash function must be renewed with any rekeying operation, due to security concerns, and the large size of the polynomials involved. The length of the messages grows linearly with the number of users in every group, so that if this number is huge, users might be forced to be distributed into subgroups, e.g., groups of users are established inside every PPC or PPV group.

The distribution by groups is in fact often beneficial and is used by most key managing protocols. A first benefit is the parallelization of the process which speeds up the rekeying operations. Secondly a compromised key in one of the groups does not affect the others. Last but not least, in most applications of secure multicast the group distribution is connected with the scalability of the system, i.e., the efficiency of the communication protocols concerning the rekeying process, with particular reference to leave and join operations. Groups are usually highly dynamic and the joining or the leaving of users implies a rekeying operation, and thus key refreshment due to this fact in one group does not affect the others.

More recently in [9] the authors introduce another solution with the same philosophy of Secure Lock and of that introduced in [7] and based on the Extended Euclidean Algorithm. Throughout this paper we will refer to this protocol as *Euclides*. The server distributes a secret via the inverse of an integer modulo a product of coprime secret numbers, each one of them belonging to an authorized user. The authors show [9] that a former user could try a factorization attack, which forces to consider prime numbers of an adequate size. This implies a division by groups of the

audience, in the case of PayTV a subdivision of every PPC or PPV group, since the length of the rekeying messages could become unaffordable as in the other computational approaches.

In this paper we introduce a new protocol for key managing in centralized multicast. We are assuming a scenario, fairly general and suitable for many applications, especially for multimedia distribution purposes, with a Key Server and a set of members (other hosts) that either send or receive multicast messages. Any multicast topology can be used underneath. All setup tasks are carried out by the Key Server. Data communications are then either one-to-many or many-to-many, and consist of encrypted contents and/or rekeying messages, which are created by the Server (or the two servers, Content Server and Key Server). Members can enter and leave the system at any time. The key must be refreshed upon member arrival or departure to achieve perfect backward and forward secrecy, respectively. However this might depend on the application, since there exist cases, such as some audio and/or video streaming distributions, where backward secrecy is not an issue, as contents can be out of date.

The protocol we are introducing presents some nice features that make it competitive, e.g. it requires just a single message per group, of affordable length, for every rekeying operation, the operations at the Key Server and the Client sides require low computational cost and the key storage requirements are minimal.

The main idea behind the protocol is the use of orthogonal systems in vector spaces. Exploiting orthogonality comes probably as a natural tool in multicast applications, as this appears also e.g. in CDMA and [16]. How orthogonality is exploited here appears though to be new, and brings with it several advantages. In particular the scalars will play an important role in order to have fast rekey and reset operations and avoid involving large vectors to be replaced or generated. Moreover this structure will make the protocol not only agile and flexible, but also more robust and secure against all conceivable attacks, as will be shown later.

In the next Section we describe the new protocol, analyse its security, and compare it with other existing and aforementioned protocols. Section III demonstrates an efficient implementation of the protocol.

## 2. THE PROPOSED PROTOCOL

Let the potential users be denoted with the integers  $1, \dots, n$  and assume that they all belong to the same group.

### (1) Initialization step:

Let  $\mathbb{K}$  be a field and  $V$  be a  $\mathbb{K}$  vector space of dimension  $m \geq n$  (see also next subsection for the choice of  $m$ ). Let  $\langle, \rangle$  be a bilinear form which we assume to be nondegenerate and symmetric. Let  $B = \{\mathbf{e}_1, \dots, \mathbf{e}_n\}$  be a set of  $n$  mutually orthogonal vectors in  $V$  having the property that  $\langle \mathbf{e}_i, \mathbf{e}_i \rangle \neq 0$  for  $i = 1, \dots, n$ . Note that these two requirements, namely the mutual orthogonality and the non self-orthogonality, also imply the linear independence of the vectors. For security reasons, as we will show later, the vectors should not be part of the canonical basis or anyway the basis used to represent vectors. We select a family  $\{x_i\}_{i=1}^n$  of random nonzero scalars in  $\mathbb{K}$ . Note that  $B' = \{x_1\mathbf{e}_1, \dots, x_n\mathbf{e}_n\}$  spans the same subspace as  $B$ . These two sets are kept secret by the server and each user  $i$  is assigned the vector  $\mathbf{v}_i = x_i\mathbf{e}_i$ . By our assumptions we know that  $\langle \mathbf{v}_i, \mathbf{v}_i \rangle \neq 0$  for  $i = 1, \dots, n$ . Then we will consider two subsets in  $B'$  at a determined point in time in the communications. On one hand  $B'_1$  will be formed by those vectors in  $B'$  that are assigned to some user and  $B'_2$  will be the set of vectors in  $B'$  that do not correspond to any user. We also consider two subsets in  $B'_2$ ,  $B'_{2,1}$  and  $B'_{2,2}$ , that contain those vectors that were not previously used and

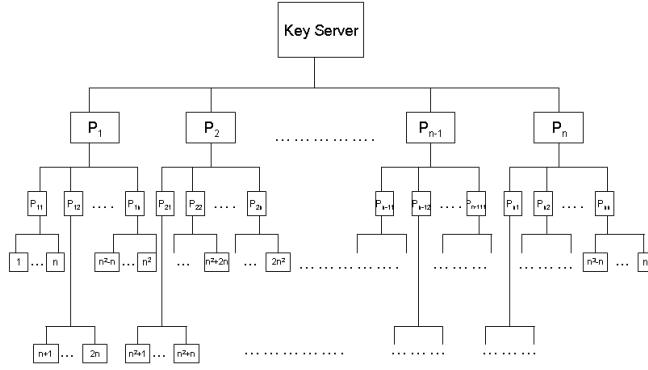

FIGURE 1. Hierarchical Tree

those that are a multiple of a vector corresponding to a former no more legitimate user, respectively.

(2) Sending the information:

Suppose that we want to distribute the secret  $s \in \mathbb{K}$ . Then we compute and multicast (broadcast)  $\mathbf{c} = s(\sum_{\mathbf{v}_j \in B'_1} \mathbf{v}_j + y \sum_{\mathbf{v}'_j \in B'_2} \mathbf{v}'_j)$  for some random  $y \in \mathbb{K}$  different for each new secret.

(3) Recovering the information:

Each user computes  $h = \langle \mathbf{c}, \mathbf{v}_i \rangle = s \langle \mathbf{v}_i, \mathbf{v}_i \rangle$ .

The secret  $s$  is then recovered by computing  $s = h \langle \mathbf{v}_i, \mathbf{v}_i \rangle^{-1}$ .

(4) Key refreshment:

(a) Join:

If user  $j$  joins, then she is assigned one of the vectors in  $B'_{2,1}$ , say  $x_j \mathbf{e}_j$ . The server selects a new secret  $s' \in \mathbb{K}$  and multicasts as above  $\mathbf{c}' = s'(\sum_{\mathbf{v}_j \in B'_1} \mathbf{v}_j + y' \sum_{\mathbf{v}'_j \in B'_2} \mathbf{v}'_j)$  for some random  $y' \in \mathbb{K}$ .

(b) Leave:

If user  $j$  leaves, then her vector  $\mathbf{v}_j = x_j \mathbf{e}_j$  is deleted from  $B'_1$  and the vector  $\mathbf{v}'_j = x'_j \mathbf{e}_j$  is included into  $B'_{2,2}$  where  $x'_j (\neq x_j)$  is selected at random in  $\mathbb{K}$ . To distribute a new secret  $s'$ , we do similarly as after a join operation.

We remark that, if we are managing with  $\ell$  groups, then we can use  $\ell$  different orthogonal bases. A particular interesting case of managing groups is shown in Figure 1. In this case one can profit from a tree-like distribution as in the HTA and the Secure Lock + HTA approaches ([15] and [12] respectively) using a divide and conquer strategy. The main advantage is that we can use smaller vector spaces, so that we can serve a much bigger number of users without delaying in rekeying operations. Let us consider for example a hierarchical tree with a depth of 4, i.e., the number of levels below root is 3, and a degree of  $n$ , i.e., the number of children below each parent node is  $n$  (see Figure 1). In this situation, we have  $n^3$  users who are located at the leaves of the tree. Intermediate nodes store group keys in the form of vectors known to the correspondent descendants. For example, users 1 to  $n^2$  share a common vector stored at  $P_1$ , users 1 to  $n$  share another common vector stored at  $P_{1,1}$  and so on, so that user 1 knows her private vector plus the vectors  $P_1$  and  $P_{1,1}$ . Then, when a rekeying message is to be sent, this will be made using the

orthogonal system given by  $\{P_1, \dots, P_n\}$  as described above, and any authorized user will be able to retrieve the key.

Now, let us assume without loss of generality that user 1 wants to leave. It can be easily observed that we need the following messages to refresh the key and preserve forward secrecy. After determining a new vector for position 1, the server uses the new basis, including the private vectors of users 2 to  $n$ , to send them a scalar (by posting an encrypted version, as described in the protocol). Users 2 to  $n$  use this scalar to renew  $P_{1,1}$ , i.e. they keep the same vector but substitute the scalar associated to it. Analogously the server uses the new basis for  $P_{1,1}$  to  $P_{1,n}$  to send the users 1 to  $n^2$  another scalar. These use this scalar to renew  $P_1$ . At last the server can send a new key for all users using the new orthogonal system for  $\{P_1, \dots, P_n\}$ .

Notice that in order to send a scalar of  $k$ -bits length we need a message of  $nk$  bits length. If we deal with a tree distribution as above where  $n = 100$ , then three rather short messages will give us the possibility of handling audiences of up to 1 million users, and the computing time to generate the rekeying messages will not depend on the number of users.

In fact, our protocol is natural from the point of view of building the tree. When designing the tree distribution we have to fix the number of descendants of each node, that will give us the required dimension for our vector space. And the tree distribution allows to have flexibility on the number of users: if a bigger structure has to be considered in order to deal with more users, then intermediate nodes can be easily inserted.

**2.1. Security.** Let us suppose that  $\mathbb{K}$  is a finite field, which is the usual setting for application. As a first step we will show that, by choosing  $m$  appropriately, we can be sure that there are sufficiently many  $n$ -tuples of mutually orthogonal vectors in  $V$ , so that a brute force attack to find  $B$  is not feasible.

As we require also the property  $\langle \mathbf{e}_i, \mathbf{e}_i \rangle \neq 0$ , for  $i = 1, \dots, n$ , we consider the set  $\{\mathbf{x} = (x_1, \dots, x_m) \in V \mid \langle \mathbf{x}, \mathbf{x} \rangle = x_1^2 + \dots + x_m^2 = 0\}$ . This set forms a hypersurface  $H$  of dimension  $m - 1$  and degree 2.

**Theorem 1.** *Let  $V := \mathbb{F}_q^m$  and  $m > 2n$ . Then there exists at least*

$$(1 + o(1)) \frac{q^{\frac{3}{2}n^2}}{n!}$$

*$n$ -tuples of mutually orthogonal vectors  $(\mathbf{e}_1, \dots, \mathbf{e}_n)$  in  $V$  having the property that  $\langle \mathbf{e}_i, \mathbf{e}_i \rangle \neq 0, i = 1, \dots, n$ . For characteristic bigger than 2 we may require  $(1 + \frac{5 \cdot 2^{13/3}}{q})q^{m-1} \ll q^m$ .*

*Proof.* We divide the proof in different scenarios, as the estimate can be made more precise depending on the particular setting involved.

In characteristic 2 (which is probably the most interesting case for cryptographic applications),  $x_1^2 + \dots + x_m^2 = (x_1 + \dots + x_m)^2$  so that the cardinality of the hypersurface  $|H| = q^{m-1}$ . Now Iosevich and Senger [5, 14] derived a lower bound on the number of  $n$ -tuples of mutually orthogonal vectors in a subset  $X \subset V$  in situations where a lower bound on the cardinality of  $X$  is known. Applying this result to our situation with  $X := V \setminus H$  one derives the thesis.

In characteristic greater than 2, we can exploit estimates on the number of points in hypersurfaces, namely the Lange-Weil bound and connected results (e.g.[1] or[6] where probably the best general bounds can be found). If  $H$  is absolutely irreducible, then  $|H| = (1 + C)q^{m-1}$ , where  $|C|$  can be estimated, independently of any regularity conditions, as less than  $\frac{5 \cdot 2^{13/3}}{q}$  ([1, Theorem 5.2]); here we may require  $q$  to be large enough to make  $|H|$  neglectable with respect to  $q^m$ . If  $H$  is

not absolutely irreducible, then  $|H| \leq q^{m-1}$  ([1, Lemma 2.3]). In any case we can apply again the same argument as in characteristic 2 and derive the thesis.  $\square$

The condition  $m > 2n$  might also be convenient in order to avoid any collusion attack, that is to avoid that a big group of, say,  $k$  users share their private vectors with each other, trying to retrieve information belonging to other authorized users. Since  $m - k > 2(n - k)$ , the inequality above guarantees that there would be anyway more than

$$(1 + o(1)) \frac{q^{\frac{3}{2}(n-k)^2}}{(n-k)!}$$

$(n - k)$ -tuples of mutually orthogonal vectors in the remaining unknown vector space.

Let us assume now that the set  $B$  is known, instead of being kept secret. Since  $B$  is a linearly independent set, one can compute readily the unique coefficients  $z_1, \dots, z_n$  such that

$$\mathbf{c} = z_1 \mathbf{e}_1 + \dots + z_n \mathbf{e}_n.$$

An authorized user knowing the vector  $\mathbf{v}_j = x_j \mathbf{e}_j$  and having computed  $z_j \mathbf{e}_j$  readily computes  $x_j$  and  $s$  from  $z_j = s x_j$ . With this all the private numbers  $x_i, i = 1, \dots, n$  can be readily computed by this user. Such a user would have the chance to use this later in her own interest. As it is often the case, inner attacks are more dangerous than outer ones.

The security is clearly compromised not only if the set  $B$  is made public, but also if just one vector of  $B'$  becomes known to unauthorized users: in fact getting  $s$  involves knowing at least one vector in the set  $B'$  used to compute  $\mathbf{c}$ . We can think at different ways for an attacker to get such a vector. Let us assume in the following without any loss of generality that the set  $B'_{2,2}$  is formed by just one vector corresponding to a single former user.

First, the former user can try to get the new  $s'$  using her vector, say  $\mathbf{v}_i$ . If she multiplies  $\langle \mathbf{c}', \mathbf{v}_i \rangle$ , then she gets

$$\langle \mathbf{c}', \mathbf{v}_i \rangle = \langle s'(x_1 \mathbf{e}_1 + \dots + y x'_i \mathbf{e}_i + \dots + x_r \mathbf{e}_r), x_i \mathbf{e}_i \rangle = s' y x_i x'_i \langle \mathbf{e}_i, \mathbf{e}_i \rangle.$$

for some random  $y$ . But now she would have to know the vector  $\mathbf{e}_i$  (or equivalently  $x_i$ ) and the value  $y x'_i$  to get the new secret  $s'$ . Also, knowing  $s'$  does not reveal anything on  $x_i$ , nor  $\mathbf{e}_i$ .

Another option consists in trying to derive some information from the difference between two different rekeying messages  $\mathbf{c}$  and  $\mathbf{c}'$ . But

$$\mathbf{c} - \mathbf{c}' = (s - s') x_1 \mathbf{e}_1 + \dots + (s x_i - s' y x'_i) \mathbf{e}_i + \dots + (s - s') x_r \mathbf{e}_r$$

Then  $\langle \mathbf{c} - \mathbf{c}', \mathbf{v}_i \rangle = (s x_i x_i - s' y x'_i x_i) \langle \mathbf{e}_i, \mathbf{e}_i \rangle$  and, as before, no information can be deduced about  $s'$ .

Let us assume now that the attacker has additional means, for example suppose a valid user shares  $s$  with a former user.

First note that forward secrecy is not violated under a known plain text attack. Indeed suppose the former user knows  $\mathbf{v}_i = x_i \mathbf{e}_i$  for some  $i$  and let  $\mathbf{v}'_i = x'_i \mathbf{e}_i$  be the unique element of  $B'_{2,2}$ . With the rekeying procedure  $\mathbf{c} = s(x_1 \mathbf{e}_1 + \dots + y x'_i \mathbf{e}_i + \dots + x_r \mathbf{e}_r)$  for some random  $y$  is multicasted. Then  $\langle \mathbf{v}_i, \mathbf{c} \rangle = s x_i y x'_i \langle \mathbf{e}_i, \mathbf{e}_i \rangle$ . If somehow this former user has access to the corresponding decrypted message,  $s$ , then she will be able to get  $x_i y x'_i \langle \mathbf{e}_i, \mathbf{e}_i \rangle$  by multiplying by  $s^{-1}$ , but this cannot be used for the following multicasted messages since  $y$  is chosen randomly with every rekeying stage.

If  $y$  was not recomputed with every rekeying message, then given a new  $\mathbf{c}' = s'(x_1 \mathbf{e}_1 + \dots + y x'_i \mathbf{e}_i + \dots + x_r \mathbf{e}_r)$  for the same  $y$  used for  $\mathbf{c}$ , then  $s'$  would result from computing  $\langle \mathbf{c}', \mathbf{v}_i \rangle (x_i y x'_i \langle \mathbf{e}_i, \mathbf{e}_i \rangle)^{-1}$ .

Forward secrecy is also not violated by a chosen plain text attack. Indeed assume that an attacker has access to an algorithm that provides the corresponding  $\mathbf{c}$  for any given message  $s$ . This is like a valid user that has access to many such pairs. Then even in this case, as a valid user she could compute for all pairs of ciphertexts  $\langle \mathbf{c} - \mathbf{c}', \mathbf{v}_i \rangle = (s - s')x_i^2 \langle \mathbf{e}_i, \mathbf{e}_i \rangle$ , but no information on  $\mathbf{e}_i$  would be leaked.

Similar arguments apply for new users concerning backward secrecy.

Finally we can imagine an attack based on the collection of many subsequent pieces of information, in a cipher text-only attack scenario. We show below that this is feasible when  $B$ , against our hypothesis, is the canonical basis used to represent vectors of the vector space  $V$ . Namely, anybody observing the information flow could get  $n$  linearly independent key refreshments  $\mathbf{c}_1, \dots, \mathbf{c}_n$ . Note that this is the case whenever a user  $i$  leaves and in that case, the set  $B' = \{x_1 \mathbf{e}_1, \dots, x_i \mathbf{e}_i, \dots, x_n \mathbf{e}_n\}$  would change to  $B'' = \{x_1 \mathbf{e}_1, \dots, yx'_i \mathbf{e}_i, \dots, x_n \mathbf{e}_n\}$ . Now, suppose without loss of generality that  $n = m$ ; if the server sends  $(s_i x_1, \dots, s_i x_n)$  as a rekeying message  $\mathbf{c}_i = (c_{i,1}, \dots, c_{i,n})$ , then we would consider the matrix

$$M = \begin{pmatrix} c_{1,1} & \cdots & c_{n,1} \\ \vdots & \vdots & \vdots \\ c_{1,n} & \cdots & c_{n,n} \end{pmatrix}$$

where each column  $(c_{i,1}, \dots, c_{i,n})$  represents the coordinates of the refreshment  $\mathbf{c}_i$  with respect to  $B$  (as  $c_{i,j} = s_i x_j$  for  $i, j = 1, \dots, n$ ); then  $M$  represents the change of basis from the basis  $C = \{\mathbf{c}_1, \dots, \mathbf{c}_n\}$  to  $B$ . The inverse of  $M$  will reveal then  $B$  in terms of the basis  $C$ . And knowing a pair  $(s, \mathbf{c})$  would compromise all the secrets (of the other users) used to get this pair  $(s, \mathbf{c})$ , as noted at the beginning of this subsection.

Therefore it is convenient, as pointed out before, that  $B$  is chosen not to be the canonical basis, so that what is sent by the server is not plainly  $(s_i x_1, \dots, s_i x_n)$ , but its representation in another basis.

Let us illustrate this with the following easy example:

**Example 2.** Let  $B = \{(1, 1, 1), (1, -2, 1), (-1, 0, 1)\}$  be an orthogonal basis of the euclidean vector space  $\mathbb{R}^3$  (with the usual scalar product  $\langle, \rangle$ ) and assume  $x_1 = 2$ ,  $x_2 = 3$ ,  $x_3 = 5$ . Then  $B' = \{(2, 2, 2), (3, -6, 3), (-5, 0, 5)\}$ .

If we want to rekey with  $s = 4$ , then we have to multicast

$$\mathbf{c}_1 = 4(2, 2, 2) + 4(3, -6, 3) + 4(-5, 0, 5) = (0, -16, 40).$$

User 1 can recover  $s$  by calculating

$$h = \langle (0, -16, 40), (2, 2, 2) \rangle = 48,$$

and then

$$s = h \langle (2, 2, 2), (2, 2, 2) \rangle^{-1} = 4.$$

Users 2 and 3 act similarly.

Now suppose that user 2 leaves and  $x_2$  is changed to  $x_2 = 2$ .  $B'_{2,2}$ , that was previously empty, contains now the vector  $(2, -4, 2)$ . Then the rekeying message for  $s = 3$  and considering  $y = 2$  is  $\mathbf{c}_2 = 3(2, 2, 2) + 3 \cdot 2(2, -4, 2) + 3(-5, 0, 5) = (3, -18, 33)$ . Finally, suppose that user 1 leaves,  $x_1$  becomes 3 and the new secret  $s$  is 2, so that, choosing  $y = -1$ ,  $\mathbf{c}_3 = 2 \cdot (-1)(3, 3, 3) + 2 \cdot (-1)(2, -4, 2) + 2(-5, 0, 5) = (-8, 2, 8)$ . Now the basis given by  $\{\mathbf{c}_1, \mathbf{c}_2, \mathbf{c}_3\}$  does not tell anything about the basis  $B$ .

**Remark 3.** It should be remarked that, if we restrict ourselves to work in a subring of the base field that admits an algorithm to compute  $GCDs$ , then  $s$  divides the  $GCD$  of the coordinates of  $c$ . Observe, for instance, that in the example above  $s$  divides  $GCD(0, -16, 40)$  and after the first rekeying  $s = GCD(3, -18, 33)$ . Thus this situation should be avoided for a security issue, so finite fields rather than the ring of integers should be used.

**Remark 4.** To add additional security and prevent any sort of statistical or brute force attacks, it is anyway advisable to perform periodic key refreshments, as is commonly done for other protocols.

**2.2. Comparison with other schemes.** We compare here our new proposal with some of the other key managing protocols existing in the literature and cited in the introduction. The main parameters we will focus on are the key storage cost and the length of the messages.

For additional comparisons, as our protocol behaves comparably to Euclides in the number of rekeying messages per join or leave, we refer to [9], in particular Table 1, where Euclides is compared with previous protocols and other features are also taken into account.

As for the protocol we are introducing in this paper, the server has to store one scalar per user, the  $x_i$ 's, and an orthogonal system,  $B$ , for each considered group, each user stores her vector  $v_i$ , while the length of the rekeying messages is  $n \cdot C$ , where  $C$  is the bit-length of the elements in a finite field  $\mathbb{K}$ .

In [9], Euclides was introduced and shown to be already very competitive with respect to existing protocols, however the present proposal offers an additional advantage concerning the length of the messages. In Euclides, in fact, the key storage cost can be of the same order as here, but the length of the messages could become a problem unless some key management by groups is used. In fact, by security requirements every private key held by any user, an integer, has to be of appropriate length to avoid a factorization attack by a former user (cf. [9]). In this way integers of length 1024 bits onwards should be considered and since the rekeying messages are of the same order as the product of all these integers, then for large groups these could be unaffordable.

On the other hand, in this new protocol messages can be considerably shorter than in Euclides, depending on the number of users in the group and on the cardinality of the field chosen for the scalars.

Suppose for example that we are dealing with a field of the order 64-bits length elements and we are using a vector space of dimension 10000. Then rekeying messages would be shorter than 80Kbytes length, which is perfectly affordable by any multicast network used for this purpose. In the case of Euclides, using primes of 64-bits length produces messages of the same length, i.e. 80Kbytes. However, any user, as it is shown in [9], has access to a multiple of the product of all the secret keys and so this bit-length of the primes is not enough for a secure rekeying process since a factorization attack would succeed very quickly. To avoid this we are forced to deal with 1024-bits length primes (at least). This leads to over 1Mbyte length rekeying messages. Otherwise we have to divide this audience in at least 12 groups in order to deal with messages of length comparable to that of the new proposal.

In the case of Secure Lock each user holds a pair of keys, an integer,  $R_i$  and a symmetric key,  $k_i$ . The server encrypts the secret using the symmetric key  $k_i$  of every user, obtaining a number for each one of them,  $N_i$ . Then the server solves the congruence system  $x \equiv_{R_i} N_i$  and multicasts the solution  $U$  of this system. We observe that, as in the case of Euclides, the length of the messages is of the same order as the product of all the integers  $R_i$  and that with every refreshment a congruence system has to be solved, which can quite slow down the rekeying process. Recall also that the server has to encrypt as many times as the number of authorized users. In order to speed it up



it is commonly used jointly with HTA. However the length of rekeying messages still depends on the users involved in each group.

As far as the Conditional Access Service introduced in [7] is concerned, amid a good behavior regarding key storage, the high degree of the polynomials involved again generally forces a partition of the users into groups. Moreover the hash function used to create the interpolator polynomial that is used to distribute the secret has to be changed with every rekeying process, as mentioned above.

In our case, the rekeying process only requires a few simple operations and is considerably faster with respect to all the previously considered protocols.

### 3. IMPLEMENTATION OF THE PROPOSED METHOD

The application was designed using three main computational objects, *the Key Sharing Framework object (KSF)*, a *Server object* and a *Client object*. The Server object is the hotspot in terms of computation due to the size of the matrix that it hosts (namely the vector space). The KSF manages clients and interfaces the GPU device, if present. The application was organized in the following stages:

- *Vector space setup*: The KSF object creates the 2D matrix consisting of mutually orthogonal vectors.
- *Coder generation*: The Vector space can be reduced by column order into a 1-D vector (using the addition). This 1-D key is used by the Server to encode the content to be distributed.
- *User/Client login*: Prepares the necessary data structures to hold users claiming a key to decode content from the Server. Once the client is authorized to log in, the key to decode messages, is provided.
- *Server initialization and startup*: The KSF framework permits the Server to accept requests from clients.

TABLE 1. Execution of the protocol CPU-only threaded version (time in ms, vector and user # in thousands, i.e. 5v x 5u stands for 5000v x 5000u)

stage	core i7 ee(12 hw threads)			dualcore T9500 (2 hw threads)		
	5v x 5u	10v x 5u	10v x 10u	5v x 5u	10v x 5u	10v x 10u
Orthogonalization	114240	913866	913596	169909	1339753	1371083
Key Refreshment	30	197	198	66	231	235
Generator Coder	30	197	198	66	231	235
Server activation	0	1	0	2	1	3
Client setup	1	1	2	46	80	168
Broadcast	12	16	33	1	1	0
Client refresh	1	1	1	45	300	556

**3.1. Results.** Jcuda ([4]), which is a Java binding for CUDA (Compute Unified Device Architecture), a set of development tools that allows programmers to use graphic cards for parallel computing- was used to interface the GPU and impersonate it as a new computational entity to which we were able to send requests (cf. Figure 2). To build and prepare the vector space Matrix in the GPU device, a kernel (code able to run on a GPU device) was written. Table 1 shows the execution scenarios and the timings in milliseconds for each protocol stage. Tests were executed on a Intel Core-i7 processor. The Server was run using vector spaces from 10 up to 10000. All

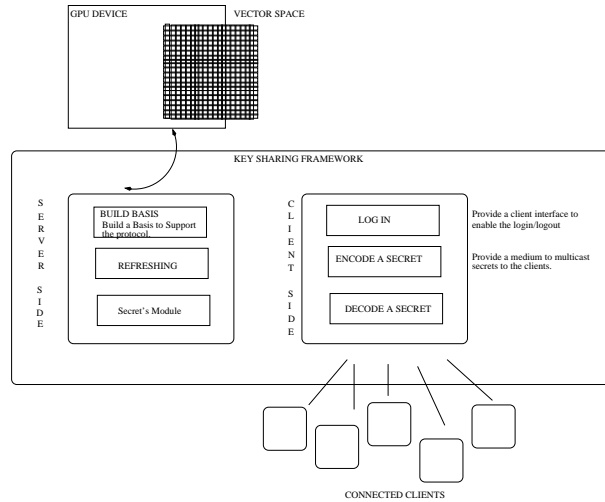

FIGURE 2. Cuda implementation schema

the cases used 4 bytes for each vector component, so that the messages produced, using a vector space of dimension 10000, are less than 40 Kbytes. The orthogonalization stage is the most time consuming step, so setup is affected as it depends on the dimension of the vector space. To test the architectural benefits of the core i7, Table 1, the server was tested in a conventional processor, core 2 duo. Although this is a laptop processor's architecture, the trend reflected in Table 1 follows the one observed in the core 2 duo case.

TABLE 2. Hardware acceleration of the orthogonalization process (in ms). The GPU used was a GForce GTX-460.

	5000v $\times$ 5000u	10000v $\times$ 5000u	10000v $\times$ 10000u
GPU Orthog.	18878.9	39000.2	40183.4
GPU to CPU	89.3	130.3	221.2

As Table 2 shows, the time spent in the Setup of the server, affected by the orthogonalization process, was reduced if a GPU was present. Another issue was the client removal and the time to renew its key to make it available for new users. This time is reflected in the stage named *Client setup*. As it can be seen, the time to refresh a client is not dependent on the dimension of the vector space.

#### 4. CONCLUSIONS

We have introduced a new protocol for managing keys in a centralized secure multicast setting. This protocol is shown to be secure against possible inner and/or outer attacks. We also showed its advantages with respect to other existing methods for key management in secure multicast schemes, namely minimal requirements for computational costs, key storage at both client and server sides, length and number of rekeying messages per join and/or leave operation. Finally we provided results showing that an efficient implementation is indeed feasible.

## REFERENCES

- [1] A. CAFURE AND G. MATERA, *Improved Explicit Estimates on the Number of Solutions of Equations over a Finite Field*, *Finite Fields and Their Applications* **12**, 2006, 155–185.
- [2] G. CHIOU AND W. CHEN, *Secure Broadcasting using the Secure Lock*, *IEEE Transactions on Software Engineering* **15**(8), 1989, 929–934.
- [3] R. DI PIETRO AND L. V. MANCINI, *Efficient and Secure Key Management for Wireless Mobile Communications*, *Proceedings of the 2nd ACM international workshop on Principles of mobile computing*, 2002, 66–73.
- [4] W. FAN, X. CHEN AND X. LI, *Parallelization of RSA Algorithm Based on Compute Unified Device Architecture*, 9th International Conference on Grid and Cooperative Computing (GCC), 2010, 174–178.
- [5] A. IOSEVICH AND S. SENGER, *Orthogonal Systems in Vector Spaces over Finite Fields*, *The Electronic Journal of Combinatorics* **15**(R151), 2008, 1–10.
- [6] G. LACHAUD AND R. ROLLAND, *On the Number of Points of Algebraic Sets over Finite Fields*, arXiv:1405.3027v2, [math.AG], 2014.
- [7] B. LIU, W. ZHANG AND T. JIANG, *A Scalable Key Distribution Scheme for Conditional Access System in Digital Pay-TV System*, *IEEE Consumer Electronics* **50**(2), 2004, 632–637.
- [8] P.S. KRUIUS AND J.P. MACKER, *Techniques and Issues in Multicast Security*, *Proceedings of Military Communications Conference (MILCOM)*, 1998, 1028–1032.
- [9] J.A.M. NARANJO, N. ANTEQUERA, L.G. CASADO AND J.A. LOPEZ-RAMOS, *A Suite of Algorithms for Key Distribution and Authentication in Centralized Secure Multicast Environments*, To appear in *Journal of Computational and Applied Mathematics*, doi:10.1016/j.cam.2011.02015.
- [10] A. PERRIG, D. SONG, AND J.D. TYGAR, *Elk, a New Protocol for Efficient Large-Group Key Distribution*, *Proceedings of IEEE Symposium on Security and Privacy (S&P)*, 2001, 247–262.
- [11] S. RAFAELI AND D. HUTCHISON, *A Survey of Key Management for Secure Group Communication*, *ACM Computing Surveys*, **35**(3), 2003, 309–329.
- [12] O. SCHEIKL, J. LANE, R. BOYER AND M. ELTOWEISSY, *Multi-Level Secure Multicast: the Rethinking of Secure Locks*, *Proceedings of International Conference on Parallel Processing Workshop*, 2002, 17–24.
- [13] A.T. SHERMAN AND D.A. MCGREW, *Key Establishment in Large Dynamic Groups using One-Way Function Trees*, *IEEE Transactions on Software Engineering* **29**, 2003, 444–458.
- [14] L.A. VINH, *On the Number of Orthogonal Systems in Vector Spaces over Finite Fields*, *The Electronic Journal of Combinatorics* **15**(N32), 2008, 1–4.
- [15] D. WALLNER, E. HARDER AND R. AGEE, *Key Management for Multicast: Issues and Architectures*, RFC 2627, 1999.
- [16] J. WANG, X. LIN, *An efficient hierarchical group key management scheme based on orthogonal vectors*, 5th International Conference on Information Assurance and Security, 2009.
- [17] C.K. WONG, M. GOUDA, AND S.S. LAM, *Secure Group Communications using Key Graphs*, *IEEE/ACM Transactions on Networking* **8**(1), 2000, 16–30.
- [18] S. ZHU AND S. JAJODIA, *Scalable group key management for secure multicast: A taxonomy and new directions*, H. Huang, D. MacCallum and D.-Z. Du, editors, *Network Security*, Springer, US, 2010, 57–75.

(José Antonio Alvarez-Bermejo) DEPARTAMENTO DE ÁLGEBRA Y ANÁLISIS MATEMÁTICO UNIVERSIDAD DE ALMERÍA 04120 ALMERÍA, SPAIN

(Juan Antonio Lopez-Ramos) DEPARTAMENTO DE ÁLGEBRA Y ANÁLISIS MATEMÁTICO UNIVERSIDAD DE ALMERÍA 04120 ALMERÍA, SPAIN

URL: [www.ua1.es/~jlopez](http://www.ua1.es/~jlopez)

(Joachim Rosenthal) MATHEMATICS INSTITUTE, UNIVERSITY OF ZURICH, CH-8057 ZURICH, SWITZERLAND

URL: [www.math.uzh.ch/aa](http://www.math.uzh.ch/aa)

(Davide Schipani) MATHEMATICS INSTITUTE, UNIVERSITY OF ZURICH, CH-8057 ZURICH, SWITZERLAND

URL: [www.math.uzh.ch/aa](http://www.math.uzh.ch/aa)

