



Informe Técnico / Technical Report



Integration of Communication Analysis and the OO Method: Rules for the manual derivation of the Conceptual Model

Sergio España, Arturo González, Óscar Pastor, Marcela Ruiz



Ref. #:	ProS-TR-2011-04		
Title:	Integration of Communication Analysis and the OO-Method: Rules for the manual derivation of the Conceptual Model		
Author (s):	Sergio España, Arturo González, Óscar Pastor, Marcela Ruiz		
Corresponding author (s):	Sergio España	sergio.espana@pros.upv.es	
	Marcela Ruiz	lrui@pros.upv.es	
Document version number:	2.0	Final version:	NO
		Pages:	38
Release date:	May 2011		
Key words:	Information systems, analysis, design, requirements engineering, conceptual modelling, model-driven development, model derivation, Message Structures, Communication Analysis, OO-Method, OLIVANOVA		

TABLE OF CONTENTS

1. INTRODUCTION.....	1
1.1. MOTIVATION OF THIS WORK.....	1
1.2. SCOPE OF THIS DOCUMENT	1
2. DERIVATION OF THE OBJECT MODEL.....	2
2.1. DERIVATION STRATEGY	2
2.2. RUNNING EXAMPLE	3
2.3. DERIVATION GUIDELINES.....	6
3. DERIVATION OF THE DYNAMIC MODEL.....	30
3.1. DERIVATION STRATEGY	30
3.2. DERIVATION GUIDELINES	30
4. REFERENCES.....	36

1. INTRODUCTION

1.1. Motivation of this work

This document presents a handbook that describes the derivation of OO-Method conceptual models from Communication Analysis requirements models. The main objective is to describe a set of rules that guide the derivation process; that is, a model transformation intended for analysts is specified. Also, the rules are illustrated using simple examples.

A more detailed application of the derivation guidelines is described in detail in the SuperStationery Co. case [1], which presents the business process model and requirements model that specify the organisational work practice of a company that sells office material, as well as how the corresponding conceptual model is derived.

The derivation guidelines presented in the following chapters have been published in conference papers [2][3]. Therefore, if you intend to cite this technical report, **please consider citing also/instead the following papers:**

A. González, S. España, M. Ruiz, and Ó. Pastor, "Systematic derivation of class diagrams from communication-oriented business process models." In: 12th Working Conference on Business Process Modeling, Development, and Support (BPMDS'11), London, United Kingdom, 2011.

S. España, M. Ruiz, A. González, and O. Pastor, "Systematic derivation of state machines from communication-oriented business process models Derivation of the dynamic view of conceptual models in an industrial model-driven development method." In: Fifth IEEE International Conference on Research Challenges in Information Science (RCIS'11), Guadeloupe, France, 2011.

1.2. Scope of this document

This document does not describe Communication Analysis and the OO-Method in full detail. For further information about these methods please refer to [González, España et al. 2008; España, González et al. 2009; España, Condori-Fernández et al. 2010; González, Ruiz et al. 2011] and [Pastor and Molina 2007], respectively.

2. DERIVATION OF THE OBJECT MODEL

2.1. Derivation Strategy

We first present a graphic overview of the derivation strategy (see Figure 1); both the Communicative Event Diagram and the Event Specification Templates contain relevant information for the derivation of the Object Model.

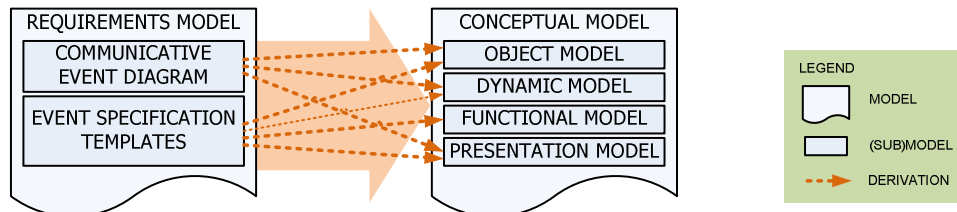

Figure 1. Derivation strategy from Communication Analysis to OO-Method models

The main step consists of processing the message structures in order to derive the class diagram view that corresponds to each communicative event. We refer as class diagram view to a portion of the class diagram that includes one or several portions of classes and structural relationships among them. By portion of a class we mean some or all of the attributes and services of the class (including their properties). The concept of class diagram view with regard to conceptual models is analogous to the concept of relational view with regard to relational database schemas [4].

Each communicative event derives a different class diagram view. The derived views are integrated to obtain the complete class diagram, the same way that different relational views are integrated to obtain a single database schema [4]. This integration can be approached in two ways [5]: post-process view integration or incremental view integration; we opt for the second. The procedure consists of the following steps. First, the communicative events are sorted. Then, the events are processed in order, one by one. The class diagram view that results from processing each communicative event is integrated into the class diagram under construction. Figure 2 exemplifies this approach. Note that one communicative event can affect one or several classes (event IV), and one class can be affected by one or many communicative events (class C).

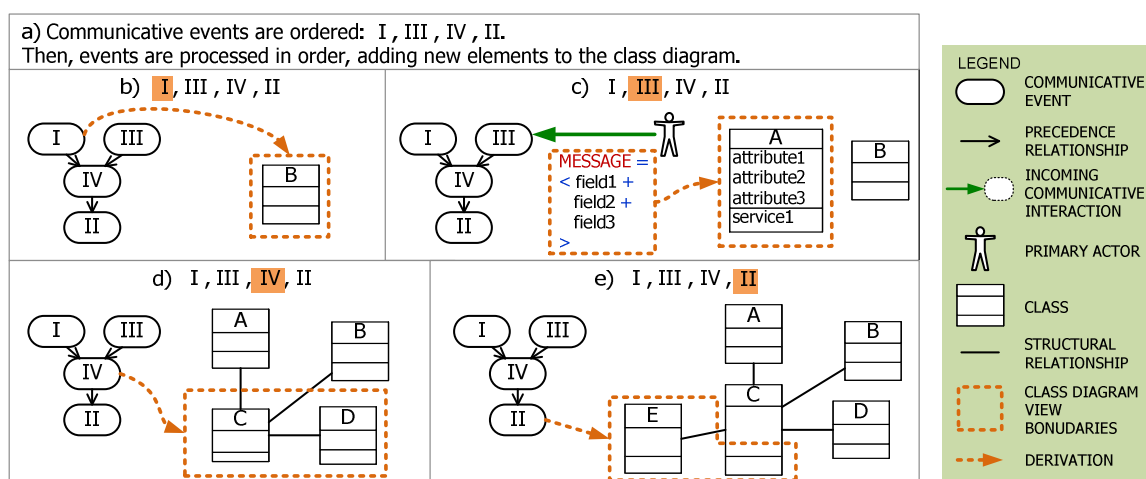

Figure 2. Simplified example of incremental class diagram view integration

By processing the communicative events in a predefined order and by performing incremental view integration, we intend to prevent a situation in which a newly-derived class diagram view refers to a

class diagram element that has not yet been derived (e.g. trying to add an attribute to an inexistent class). In any case, if the requirements model suffers incompleteness, this situation cannot be fully prevented.

2.2. Running example

This section presents a simple case that is used below to illustrate the derivation rules. The illustrative case corresponds to part of the business processes of a fictional hospital named University Hospital Santiago Grisolía.

The University Hospital Santiago Grisolía is a state entity that provides medical services to its patients. The hospital mission is to improve the health of its patients by providing a personalised and sensitive healthcare, for which purpose many business processes have been carefully defined. One of them is the *Medical treatment* process. Most patients go to the hospital to ask an appointment with a doctor. Doctors prescribe medical treatments to treat the illnesses of the patients¹. When a patient keeps an appointment with the doctor, the doctor specifies the medical treatment, by filling in the corresponding form. In the medical treatment form, the doctor specifies the initial and final date of the treatment, the nurse that will provide the medicaments, and the list of medicaments, specifying dosage, frequency, pain scale and sedation scale. Later on, the nurse assigns the dispensary where the medicaments will be provided, and she determines the delivery date (i.e. the date in which the patient can pick them up).

Figure 3 presents part of the communicative event diagram (CED) of the *Medical treatment* business process. Note that some communicative events that appear in the Figure 3 have precedent events that belong to other business processes (*APP 1*, *Dis 1*, *NUR 1* and *MED 1* are events that belong to other business processes). These business processes are specified separately; i.e. they have their own CED and event specification templates {España, 2009 #1}.

¹ Obviously, in actual work practices, doctors make decisions according to the results of the anamnesis (i.e. the interview by which the doctor elicits information from the patient) and the appropriate medical tests (e.g. X-rays, blood tests, etc.). The reader should take into account that the illustrative case intends to be very simple, even if it ends up being simplistic. A detailed application of the derivation technique on a more realistic problem can be found in [1].

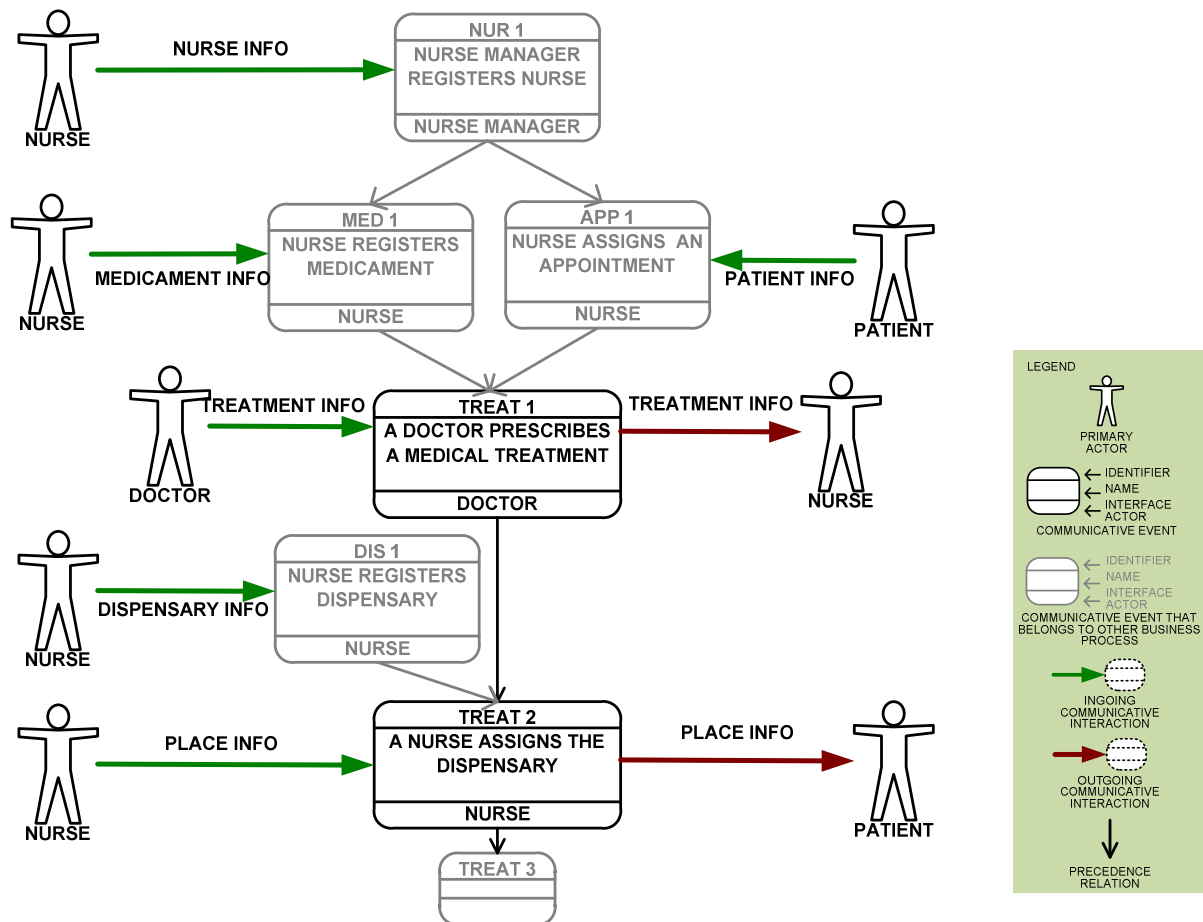

Figure 3. Comunicative event diagram of the Medical treatment business process (*TREAT*)

The event description templates for the communicative events *TREAT 1* and *TREAT 2* are included below.

TREAT 1. A doctor prescribes a medical treatment

1. General information

Goals

The objective of the hospital is to attend the patients when they request medical services. From the point of view of the information system, the objective of this event is to record the medical treatment that is prescribed to a patient.

Description

Most patients go to the University Hospital Santiago Grisolia to ask for an appointment with a doctor. Doctors prescribe medical treatments to treat the illnesses of the patients. When a patient keeps the appointment with the doctor, the doctor prescribes the medical treatment and fills out a medical treatment form. In the medical treatment form, the doctor specifies the initial and final date of the treatment, the nurse that will provide the medicaments, and the list of medicaments, specifying dosage, frequency, pain scale and sedation scale.

2. Contact requirements

Actor responsibilities

- **Primary actor:** Doctor
- **Communication channel:** In person
- **Interface actor:** Doctor

3. Communication requirements

Message structure

Table 1. Message structure of the communicative event *TREAT 1*

FIELD	OP	DOMAIN	EXAMPLE VALUE
MEDICAL TREATMENT =			
< Treatment number +	g	number	26411
Initial date +	i	date	01-08-2004
Final date +	i	date	01-08-2005
Patient +	i	Patient	842133-W, Richard Pain
Nurse +	i	Nurse	APCB
Comments +		Text	
MEDICATIONS =			
{ MEDICATION =			
< Medicament +		Medicament	Folic Acid, Tab 1Mg
Dosage +	i	text	1 tab 1Mg
Frequency +	i	text	Every morning
Pain scale +	i	text	No pain
Sedation scale	i	text	Wide awake
>			
}			
>			

Structural restrictions

One medical treatment is specific for exactly one patient.

One patient can have many medical treatments.

Contextual restrictions

Medical treatments are identified by the treatment number.

4. Reaction requirements

Treatments

The medical treatment is recorded.

Linked communications

The nurse is informed of the medical treatment has been prescribed.

TREAT 2. A nurse assigns the dispensary

1. General information

Goals

The objective of the hospital is to assign the most appropriate dispensary where the medicaments will be provided.

Description

The nurse assigns the dispensary where the treatment will be provided, and she assigns the treatment delivery date.

2. Contact requirements

Actor responsibilities

- **Primary actor:** Nurse
- **Communication channel:** In person
- **Interface actor:** Nurse

3. Communication requirements

Message structure

Table 2. Message structure of the communicative event *TREAT 2*

FIELD	OP	DOMAIN	EXAMPLE VALUE
DISPENSARY =			
< Treatment +	i	Medical treatment	26411
Delivery date +	i	date	03-08-2004
Dispensary +	i	Dispensary	SG Lab
>			

Structural restrictions

One dispensary can be assigned to many medical treatments.

One medical treatment is assigned to exactly one dispensary.

4. Reaction requirements**Treatments**

The medical treatment is recorded.

Linked communications

The patient is informed of dispensary and delivery date.

2.3. Derivation guidelines

In the following, we provide the derivation guidelines to construct the class diagram.

First, the communicative event diagram is extended with precedent communicative events so as to obtain a rooted directed graph (see rule **OM1**)².

Rule OM1. Extension of the communicative event diagram	
Preconditions	
	None
Textual explanation	
1	Include any communicative event that is not included in the communicative event diagram being processed, but it precedes a communicative event which is included in the diagram (review other precedent business processes).
2	Repeat step 1 until no more events are included.
Example	
Figure 4 presents an example of an extension process of a communicative event diagram. Business process <i>A</i> will be extended with the communicative events that are needed from other related business processes in order to obtain a rooted directed graph.	

² To illustrate this derivation rule, several communicative event diagrams are needed; in order to avoid complicating the running example, we illustrate the application of this rule using a different example.

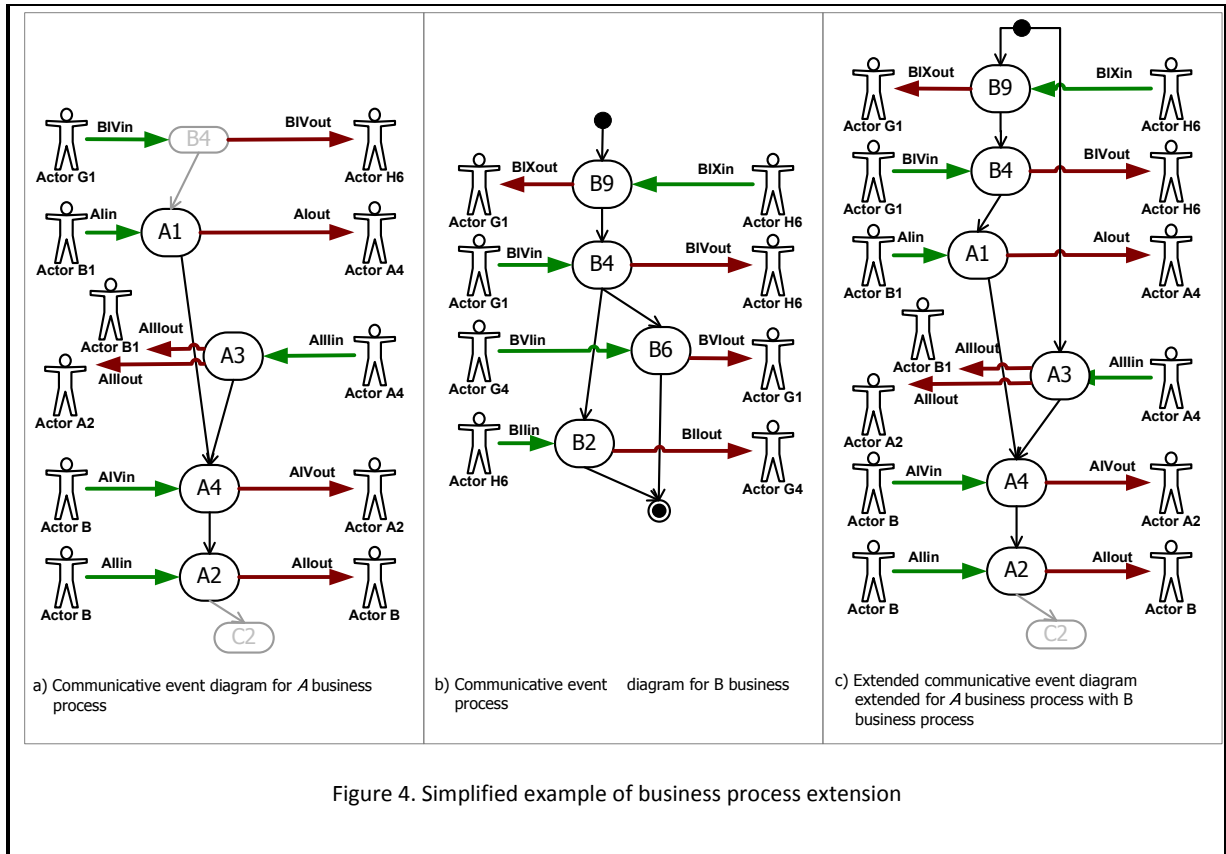

Figure 4. Simplified example of business process extension

It is also noteworthy that the communicative event diagram of business process A (see Figure 4.a) does not include a start node, while B does (See Figure 4.b). A communicative event is preceded by the start node to remark that it is not preceded by any communicative event. Each of the communicative events of business process A has at least one precedent event, either from business process itself or from a different business process (e.g. A4 has A1 and A3 as precedents; A1 has the communicative event B4 as precedent; in the B business process B4 is preceded by B9).

A similar line of reasoning is done for the end node. A communicative event is followed by an end node to remark that it does not precede any other communicative event. In business process A, each communicative event precedes another event (event A2 precedes C2, although it is out of the scope of this illustrative example). In contrast, in the business process B, B2 and B6 do not precede any other communicative event; therefore, B2 and B6 are followed by an end node.

Note that the communicative event C2 is out of the scope of this analysis, and in the moment of extend the communicative event diagram, this communicative event is not processed.

Figure 4.c presents the extended communicative event diagram for business process A (this includes the communicative events that are precedents to any of the events in business process A). The start node and end node can be omitted of the sake of simplicity (i.e. to avoid many line crossings).

Figure 5 presents an extended communicative event diagram of business process A that omits the start node

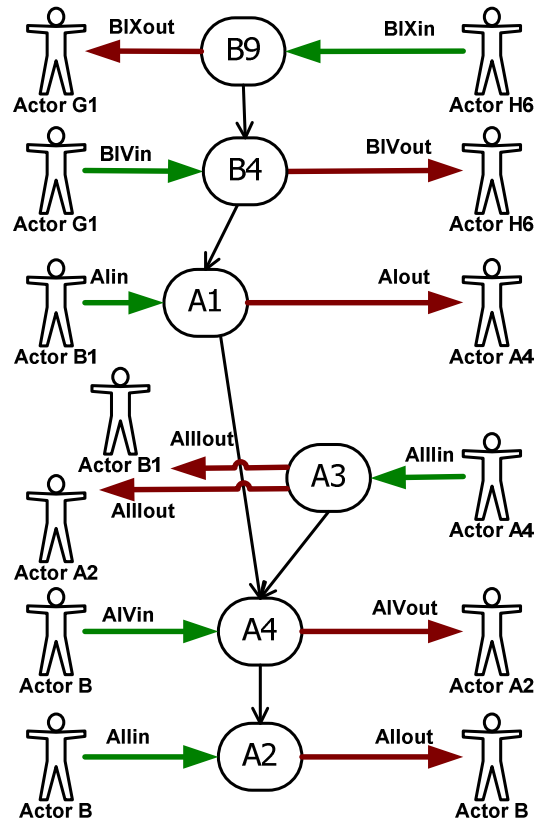

Figure 5. Extended diagram that omits the start node for the sake of clarity

Now returning to the running example, in the business process *Medical treatment*, as a pre-processing step of the message structures, the analyst marks those reference fields which indicate that (part of) a business object is being extended with new information. These marks can be supported by means of a new Boolean property for reference fields named *Extends business object* in the message structure description (see rule **OM2**).

Rule OM2. Marking of reference fields	
Preconditions	
	Rule OM1 has already been applied.
Textual explanation	
1	Add a new Boolean property (i.e. column) named <i>Extends business object</i> to every message structure of the requirements model. The new property only applies to reference fields.
2	Mark each reference field that indicates that an aggregation substructure is describing the provision of new information about an already-known business object. The mark consists of setting the new property to True .
Example	
When this rule is applied to the communicative event <i>TREAT 1. A doctor prescribes a medical treatment</i> , no changes are made, because the event does not extend a business process but actually creates a new one. Therefore, we focus on communicative event <i>TREAT 2. A nurse assigns the dispensary</i> , please see the event description template on page 5.	
Given to the meaning of the communicative event (its pragmatic consequences), the reference field Treatment actually specifies that the nurse selects an existing medical treatment form in order to make a decision. She decides when and where the treatment	

will be delivered. Then she adds this information to the form.

Table 3. Message structure of the communicative event *TREAT2* marked according to rule **OM2**

FIELD	OP	DOMAIN	EXAMPLE VALUE	EXTENDS BUSINESS OBJECT
DISPENSARY = < Treatment + Delivery date + Dispensary + >	i i i	Medical treatment date Dispensary	26411 03-08-2004 SG Lab	True

Therefore, the reference field **Treatment** is referencing a business object being extended with new information; namely, `MEDICAL_TREATMENT`. According to this derivation rule, **Treatment** should have its property *Extends business object* set to **True**.

Note

Only one reference field per aggregation substructure can be marked.

It is not necessary to mark as **False** the remaining reference fields (**False** is considered the default value).

Then, the communicative events depicted in the extended communicative event diagram are ordered according to the precedence relationships (see Rule **OM3**). For this purpose, a partially ordered set of communicative events is obtained by removing the loopbacks that might appear in the extended communicative event diagram. The remaining precedence relations define a strict partial order among the events. Any known procedure for topological sorting can be used for obtaining the ordered list of events; for instance, the algorithm proposed by Kahn [6]. Often many solutions (a.k.a. linear extensions) are possible; any solution is suitable for derivation purposes and the choice is not expected to influence efficiency.

Rule OM3. Event ordering	
Preconditions	
	Rule OM1 has already been applied.
Textual explanation	
1	Remove the loopbacks that might appear in the extended communicative event diagram and remove every other model element except for precedence relationships and communicative events.
2	L = empty list that will contain a sorted list of communicative events.
3	S = set of communicative events whose incoming precedence relationship comes from the start node.
4	While S is not empty
5	Remove a communicative event e from S .
6	Insert e into L .
7	For each communicative event f with a precedence relationship p from e to f do
8	Remove precedence relationship p from the diagram.
9	If f has no other incoming precedence relationships then insert f into S .

Example

Figure 6 a shows the poset³ of communicative events of a given diagram⁴. Figure 6.b presents all the ordered lists of events that are compatible with the partial order defined by the precedence relations. Take into account that any of these solutions is suitable and, thus, only one of the lists needs to be obtained.

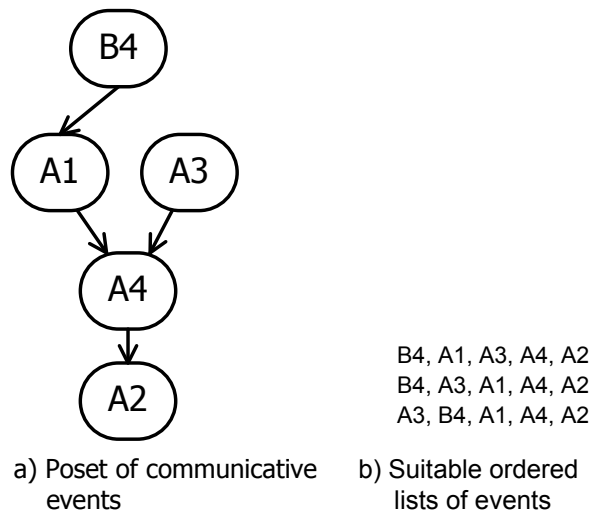

Figure 6. Example of event ordering

Note that the list A1, B4, A3, A4, A3 would not be suitable because A1 cannot appear before B4 (there is a precedence relation between them in the opposite direction).

After applying the rule OM3, we have a suitable ordered list. This list guides the order for processing the communicative events. For each event, its message structure is processed to obtain the class diagram view that corresponds to the communicative event. In the running example of the hospital, we do not present the whole derivation; however, a possible order in which the communicative events in Figure 3 can be processed is: *NUR 1, MED 1, APP 1, TREAT 1, DIS 1, TREAT 2*.

The message structure presented in Table 1 consists of an initial aggregation structure named **MEDICAL TREATMENT** that includes an iteration substructure named **MEDICATIONS**. This iteration substructure has an aggregation substructure inside of it (**MEDICATION**).

Each aggregation substructure that does not contain a reference field that has been marked according to **OM2**, leads to the derivation of a new class (see rule **OM4**).

³ A poset consists of a set together with a binary relation that indicates that, for certain pairs of elements in the set, one of the elements precedes the other. In our case, the binary relation is defined by the precedence relationships. If a communicative event A precedes another communicative event B then we can consider that $A < B$. The start node (even if it is implicit) is the *least element* of the poset.

⁴ Again, a simpler example than the hospital case is used, for the sake of brevity.

Rule OM4. Class creation	
Preconditions	
	Rule OM2 has already been applied.
Textual explanation	
1	For each aggregation substructure that <i>does not</i> contain a reference field whose property <i>Extends business object</i> is True (i.e. the field has been marked according to OM2), create a new class.
Example	
The two aggregation substructures showed in Table 1 lead to the derivation of the classes <code>MEDICAL_TREATMENT</code> and <code>MEDICATION</code> respectively.	

The name of the aggregation substructure can be used to name the class (see rule **OM5**), spaces are replaced by underscores; however, the analyst can decide to give the class a different name.

Rule OM5. Assign the class a name	
Preconditions	
	Rule OM4 has already been applied.
Textual explanation	
1	For each newly-derived class, assign to the name of the class the name of its corresponding aggregation substructure.
2	Replace spaces by underscores and use uppercase letters.
3	In any case, the analyst can choose to give a different name to a class.
Example	
Figure 7 shows the derivation of classes from aggregation substructures (see rule OM4) and assignation of a name to each class.	
<pre> MEDICAL TREATMENT = < Treatment number + Initial date + Final date + Patient + Nurse + Comments + MEDICATIONS = { MEDICATION = < Medicament + Dosage + Frecuency + Pain scale + Sedation scale > } </pre>	
Figure 7. Creation of classes and name assignation	

The aggregation substructures `MEDICAL TREATMENT` and `MEDICATION` include data fields. For instance, the complex substructure `MEDICAL TREATMENT` includes the data fields Treatment number, Initial date Final date and Comments. For each data field of a substructure, its corresponding class is added an attribute (see rule **OM6**).

Rule OM6. Add attributes to each class	
Preconditions	
	Rule OM5 has already been applied.
Textual explanation	
1	For each data field of the substructure, add an attribute to the previously-derived class.
Example	
The data field Treatment number leads to adding the attribute treatment_number to the class MEDICAL_TREATMENT; the same is done for the data fields Initial date, Final date and Comments.	

The names of the attributes are derived from the names of the data fields (see rule **OM7**), spaces are replaced by underscores and lowercase letters are used.

Rule OM7. Assign a name to the attributes	
Preconditions	
	Rule OM6 has already been applied.
Textual explanation	
1	Assign the name to attribute according to its corresponding data field (i.e. the data field from which the attribute is derived).
2	Replace spaces by underscores and use lowercase letters.
3	In any case, the analyst can choose to give a different name to an attribute.
Example	
The Treatment number data field leads to adding the attribute treatment_number to the class MEDICAL_TREATMENT; the same are done for the data fields Initial date Final date and Comments (see Figure 8).	
<pre> MEDICAL TREATMENT = < Treatment number + Initial date + Final date + Patient + Nurse + Comments MEDICATIONS = { MEDICATION = < Medicament + Dosage + Frecuency + Pain scale + Sedation scale } > </pre>	
Figure 8. Creation of the attributes treatment_number, initial_date, final_date and Comments	

The information contained in the event specification templates (e.g. message structures, structural restrictions and contextual restrictions) is used to derive the class identifier and to derive other properties such as the attribute data types, their sizes, whether they allow null values, etc.

Table 4 presents the specification of the attributes of the class `MEDICAL_TREATMENT` after processing the event `TREAT 1`. In the following, we explain how this information is derived.

Table 4. Specification of the attributes of the class `MEDICAL_TREATMENT` after processing the event `TREAT 1`⁵

Attribute name	Id	Attribute type	Data type	Size	Requested	Null allowed
treatment_number	yes	Constant	Autonumeric	-	yes	no
initial_date	no	variable	Date	-	yes	no
final_date	no	Variable	Date	-	yes	no
comments	no	Variable	String	200	yes	yes

The requirements model should specify how the organisational actors identify business objects of each kind. If available, this information is specified as a contextual restriction and it offers guidance for selecting which attributes constitute the class identifier (see **OM8**). In the absence of such restrictions, then the analyst should ask the users or decide relying on his/her own judgement.

Rule OM8. Select class identifier	
Preconditions	
	Rule OM7 has already been applied.
Textual explanation	
1	In case there exists a contextual restriction in the event specification template that indicates which message structure field (or set of fields) should be used to identify a given business object (or a part of it), then this information is used to select which attributes constitute the class identifier.
2	In the absence of such restriction, the analyst should ask the users or decide relying on his/her own judgement. An option is to create an artificial autonumeric identifier and give it the name <code>class_name_id</code> (i.e., the class name with the suffix <code>_id</code>).
Example	
According to the event specification template (See page 4), the class <code>MEDICAL_TREATMENT</code> is identified by a Treatment number, so the attribute <code>treatment_number</code> is designated the class identifier. In Table 4 is specified in the column Id .	

The attribute type should be asked to the users taking into account that, once a constant attribute has been initialised, its value cannot be modified. In contrast, variable attributes can be modified (as

⁵ These tables are not part of the requirements model; they are part of the conceptual model. At the beginning of the derivation process, such tables do not exist. Whenever a class is created (by means of applying rule **OM4**), an empty table is created. Later, whenever a class attribute is derived (by means of applying rule **OM6**), an empty row in the corresponding table is created. As the properties of the attributes are derived, the columns are filled.

long as the proper class services are defined)⁶ [7]. However, by default, all attributes that are part of the class identifier are defined as constant; the rest are defined as variable since it is the less restrictive option (see **OM9**).

Rule OM9. Specify attribute type	
Preconditions	
	Rule OM7 has already been applied
Textual explanation	
1	By default, the attributes that are part of the class identifier are defined as constant, the rest are defined as variables.
2	However, the analyst should ask the users the following question
3	“Consider that this piece of information about a business object (indicate the attribute name) is set a value in a given moment; is it possible that this information needs to be changed later?”
4	If the response is “Yes, it should be possible to change this piece information later” then the attribute type is variable.
5	If the response is “No, the initial value is never changed” then the attribute type is constant.
Example	
The attribute <code>treatment_number</code> is part of the class identifier. This means that the attribute is of type Constant. The information about the attribute type is specified in Table 4. The remaining attributes are of type variable by default. In any case, the analyst should ask the users whether the information related to these attributes needs to be changed later or not.	

The data types of the attributes are derived from the domains of their corresponding message structure data fields (see rule **OM10**). Communication Analysis prescribes a few basic domains for data fields (which serve the purpose of clarifying the meaning of the messages), whereas the OO-Method offers a wider selection of data types for attributes (code generation is intended).

Table 5 defines a correspondence between Communication Analysis data field domains and OO-Method attribute data types, thus offering some guidance for the conversion.

Table 5. Conversion table for attribute data types

Communication Analysis Data field domain	OO-Method Attribute data type⁷
number	Nat, Int, <u>Real</u> , Autonomic ⁸

⁶ Take into account that, according to the *OLIVANOVA*, constant attributes can only be initialised by means of the creation service; therefore, an attribute not being requested upon creation and of type constant is useless. This is a restriction of the tool and it does not apply to the OO-Method. According to the method, a constant attribute can have its value initialised in an edition service as well.

⁷ We clarify the meaning of some data types that are not straightforward: *Nat* stands for natural number, *Int* for integer, *Autonomic* refers to a sequence of natural numbers that is incremented automatically every time an instance is created, *String* refers to an array of characters of a specified length, *Text* refers to a multi-line text, *Bool* stands for Boolean, *Blob* stands for binary large object.

⁸ Take into account that the data type Autonomic should only be used for constant attributes (e.g. class identifiers).

text	<u>String</u> , Text
date, time	Time, Date, <u>DateTime</u>
money	Real
<i>not considered</i>	Bool, Image, Blob

Rule OM10. Specify attribute data type	
Preconditions	
	Rule OM7 has already been applied
Textual explanation	
1	Assign the attribute data type according to the conversion table for attribute data types (see Table 5).
2	Some data field domains can be converted to several attribute data types; in these cases, the analysts should apply their criteria. However, the data types that are underlined are the ones that are recommended in case of doubt.
3	In case a String data type is chosen, then the Size (the maximum amount of characters that the string attribute will allow to store) needs to be defined. For this purpose, the analyst asks the users or decides relying on his/her own judgement.
Example	
<p>In order to derive the data type of the attribute <code>treatment_number</code> of class <code>MEDICAL_TREATMENT</code>, we first trace back the message structure data field from where the attribute has been derived: it is Treatment number (see Figure 8). The domain of Treatment number is <code>Number</code> (see page 5). This domain is looked up in the first column of Table 5 (first row) and one of the corresponding OO-method attribute data types can be chosen (either Nat, Int, Real or Autonomic). Autonomic is chosen because, in this case, an automatic sequence of natural numbers is convenient for identifying medical treatment forms. Finally, this property of the attribute <code>treatment_number</code> is specified in Table 4. Column Data type.</p> <p>Similarly, the data fields that correspond to the attributes <code>initial_date</code> and <code>final_date</code> are Initial date and Final date, respectively. The domain of both data fields is <code>date</code>, so a Date time data type is chosen for the attributes. With regards to the attribute <code>comments</code>, it has been derived from the data field Comments, which has a <code>text</code> domain; therefore a data type String is chosen. Since this data type needs a size, the analyst asked the doctors how long were the longest comments they usually write in medical treatment forms: an appropriate size is 200 characters. The size is specified in Table 4. Column Size.</p>	

In a newly-derived class, all the attributes are set as requested at creation time (see rule **OM11**).

Rule OM11. Set attributes as requested at creation time	
Preconditions	
	Rule OM7 has already been applied.
Textual explanation	

1	In case the class has been created during the processing of the current communicative event (i.e. it is a newly-derived class), then set every attribute as <i>Requested upon creation</i> .
2	On the contrary, the new attributes that are added to a class when it is extended (i.e. when processing a successor event that affects an already-existing business object) should not be requested upon creation, because the information they contain is not provided when the instance is created, but in a later moment.
Example	
Since the class <code>MEDICAL_TREATMENT</code> is derived for the first time during the processing of the event <code>TREAT 1</code> , therefore all of the newly-derived attributes are set as <i>Requested upon creation</i> . This has been indicated in Table 4, column Requested .	

Whether an attribute should allow null values or not needs to be asked to the users (or the analyst should decide relying on his/her own judgement). However, by default, all attributes that are part of the class identifier are added a restriction so that they do not allow null values; the rest of the attributes are set to allow null values (see rule **OM12**).

Rule OM12. Allow null values for the attributes	
Preconditions	
	Rule OM7 has already been applied.
Textual explanation	
1	If the attribute is part of the class identifier, then set the value of the property Null allowed to "No".
2	Else, set the value to "Yes".
Example	
Since the class identifier is <code>treatment_number</code> , then this attribute is set to not allow null values. With regards to <code>initial_date</code> and <code>final_date</code> , although they are not part of the class identifier, the analyst decides to make them compulsory based on the comments by the users. The attribute <code>comments</code> is set to allow null values, because it is not mandatory that the doctor comments on the medical treatment.	

The nesting of complex substructures leads to the derivation of structural relationships between the classes that correspond to the substructures (rule **OM13**).

Rule OM13. Nesting substructures derives structural relationships	
Preconditions	
	Rule OM5 has already applied.
Textual explanation	
1	Create a structural relationship between the classes that correspond to every pair of nested aggregation substructures.
Example	
The aggregation substructure <code>MEDICATIONS</code> is part of the aggregation substructure <code>MEDICAL_TREATMENT</code> , then, the corresponding classes	

(MEDICAL_TREATMENT and MEDICATION, respectively) are related by means of a structural relationship (see Figure 9).

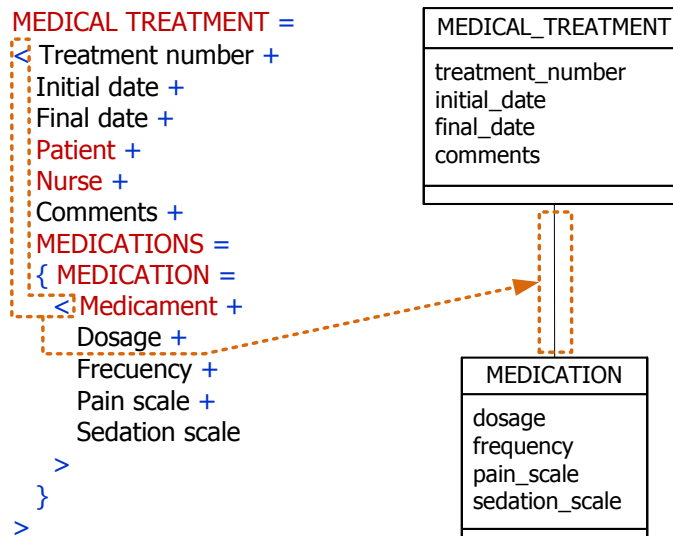
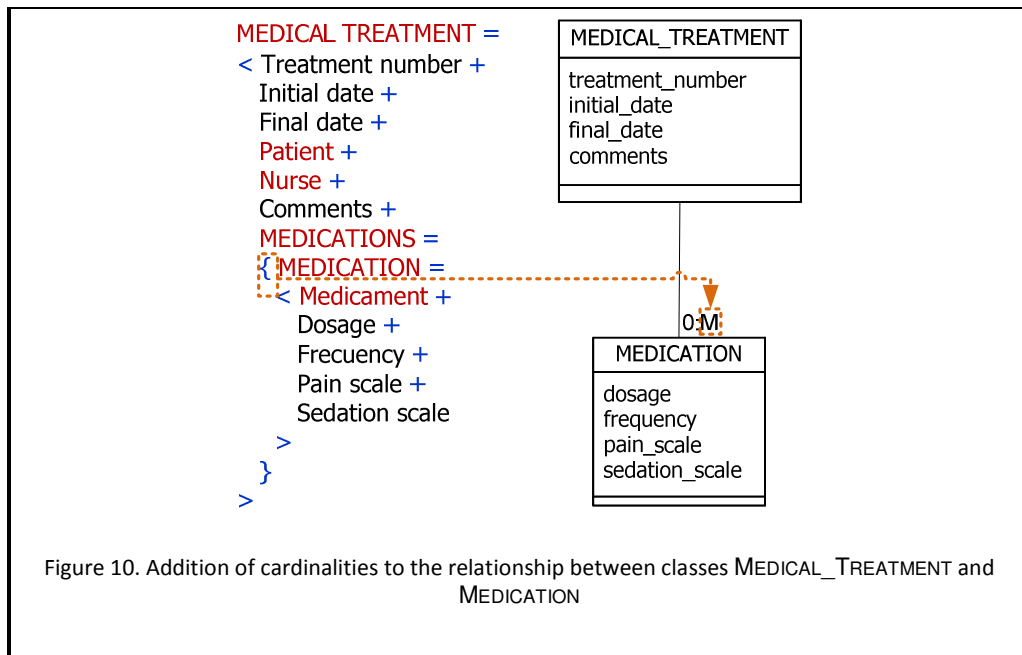

Figure 9. Relationship between the classes MEDICAL_TREATMENT and MEDICATION

For the structural relationships derived from substructure nesting, it is possible to also derive the cardinality⁹ (see rule **OM14**).

Rule OM14. Assign cardinality (analysis of aggregation substructures)	
Preconditions	
	Rule OM13 has already applied.
Textual explanation	
1	If the nested substructure is an aggregation substructure then specify that the maximum cardinality on the side of the referenced class is 1.
2	If it there is an iteration substructure in between, then this cardinality in M (many).
Example	
Since MEDICATIONS (the substructure that relates MEDICAL_TREATMENT and MEDICATION) is an iteration substructure, then the structural relationship has maximum cardinality M on the side of class MEDICATION (i.e. the iteration specifies that one medical treatment can consist of the prescription of many medications); see Figure 10.	

⁹ We acknowledge that cardinality is often referred to as multiplicity since UML became a de-facto standard; however, OO-Method still uses this term [Pastor and Molina 2007]. Also, the notation in *OLIVANOVA* departs from the UML: CLASSA minA:maxA --- minB:maxB CLASSB.



Now, the remaining cardinalities depend on structural restrictions that appear in the event description templates (see rule **OM15**).

Rule OM15. Assign cardinality (analysis of structural restrictions)	
Preconditions	
	Rule OM14 has already applied.
Textual explanation	
1	Assign the rest of the cardinalities according to structural restrictions included in the event description template.
2	In the absence of such restrictions, the analyst should ask the users or decide relying on his/her own judgement.
Example	
There is no structural restriction regarding the remaining cardinalities. Based on the analyst's experience, the cardinality on the side of MEDICAL_TREATMENT is 1:1 (see Figure 11).	
Note that a possible structural restriction could have been "One medication prescription corresponds to one and only one medical treatment". This restriction would have led to the same cardinalities.	

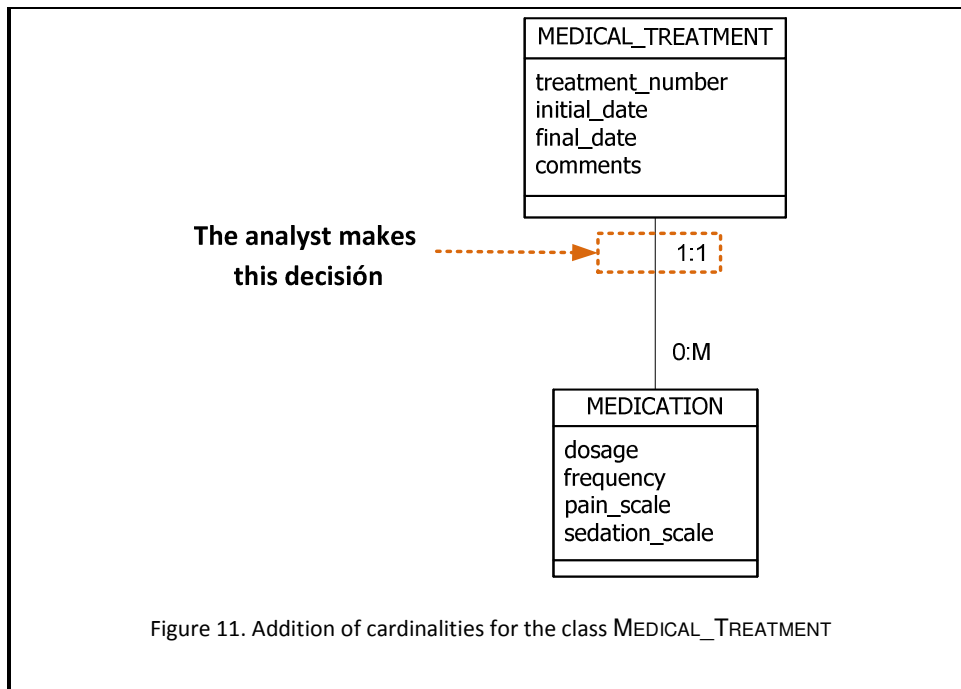

Reference fields lead to the derivation of structural relationships between the class that corresponds to the complex substructure containing the reference field and the class that corresponds to the reference field (see **OM16**).

Rule OM16. Reference field derives structural relationship	
Preconditions	
	Rules OM5 Has already applied.
Textual explanation	
1	For each reference field create a structural relationship between the class that correspond to the complex substructure containing the reference field and the class that corresponds to the reference field.
2	Note that, as long as the communicative events have been properly sorted and processed in order (see OM3), the classes that corresponds to the reference field have already been derived during a previous event processing. Otherwise, the requirements model suffers from incompleteness (e.g. a communicative event is missing).
Example	
At this moment of the derivation, the processing of previous communicative events has already led to the derivation of several classes (we depict them in grey in Figure 12).	
The reference field Patient belongs to the complex substructure MEDICAL TREATMENT , whose corresponding class is MEDICAL_TREATMENT. The domain of Patient is Patient (see page 5); during the processing of communicative event <i>PAT 1</i> , the class PATIENT was derived. Therefore, a structural relationship is defined between the classes MEDICAL_TREATMENT and PATIENT.	
A similar reasoning is done for the reference fields Nurse and Medicament .	

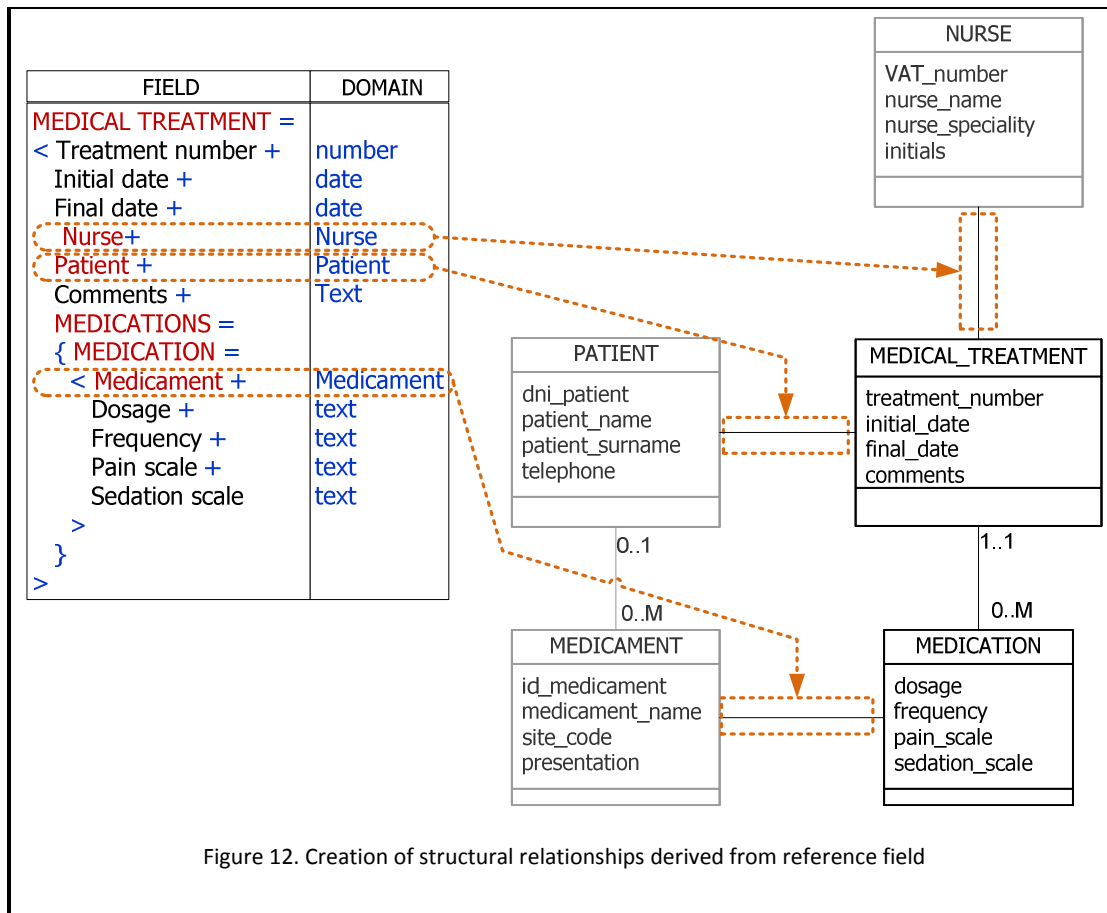

Then, the cardinalities for these structural relationships are assigned according to **OM17**

Rule OM17. Assign cardinalities (analysis of reference fields)	
Preconditions	
	Rule OM16 has already applied.
Textual explanation	
1	Assign the maximum cardinality 1 on the role side of the referenced class. Note that, if a higher cardinality had been intended, an iteration substructure should have been used instead of a reference field.
2	With regards to the minimum cardinality and the cardinalities on the other role side of the relationship, assign them according to the structural restrictions included in the event description template (see rule OM15).
Example	
Following the example, the message structure of <i>TREAT 1</i> includes a reference field that refers to a patient; it represents the patient for whom the medical treatment is prescribed. Thus, the maximum cardinality on the side of class <i>PATIENT</i> is 1. Also, there is a structural relationship in the event specification template stating that “A medical treatment is specific for exactly one patient” (see page 5). Thus, applying rule OM15 (step 1), the minimum cardinality on the side of class <i>PATIENT</i> is 1, as well. Although there is no explicit structural restriction concerning the cardinalities on the role side of the class <i>MEDICAL_TREATMENT</i> , the analyst applied rule OM15	

(step 2) and, relying on her knowledge of the field, opted for cardinalities 0:M. This derivation is depicted in Figure 13.

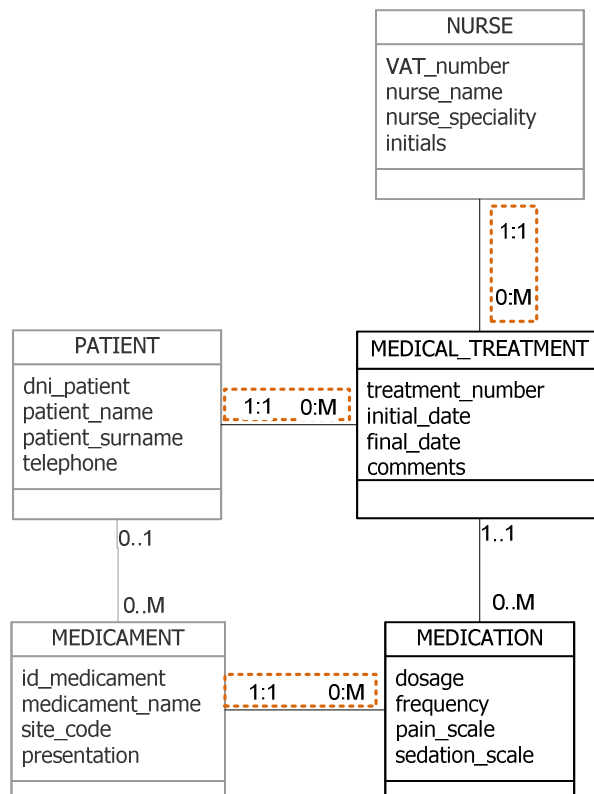
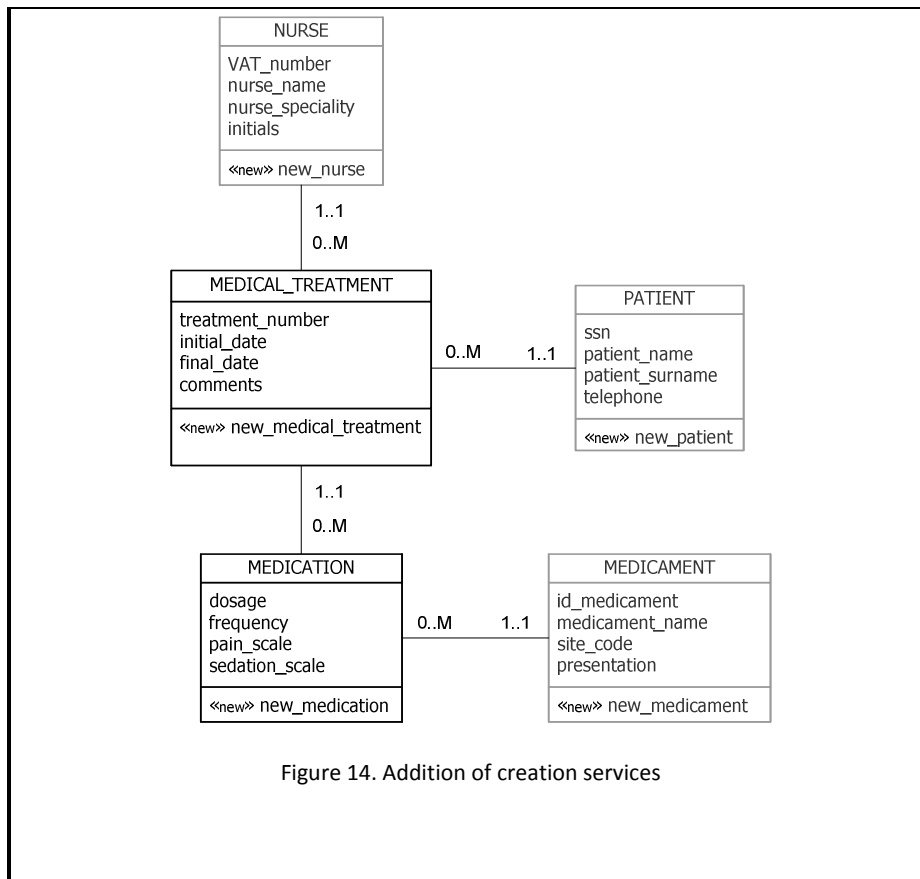

Figure 13. Specification of the cardinalities among the classes MEDICAL_TREATMENT, MEDICATION, PATIENT and MEDICAMENT

A similar reasoning applies to the cardinalities of the relationship between MEDICATION and MEDICAMENT.

Additionally, a creation service is added to each newly-derived class (see **OM18**).

Rule OM18. Addition of a creation service	
Preconditions	
	Rule OM5 has already been applied
Textual explanation	
1	Add a creation service for each newly-derived class.
2	The analyst can freely decide the name of the creation service, although it is recommended to give it the name <code>new_class_name</code> (i.e., the class name with the prefix <code>new_</code>).
Example	
For instance, a service named <code>new_medical_treatment</code> is added to the class MEDICAL_TREATMENT (see Figure 14). Similarly, the class MEDICATION is added a creation service named <code>new_medication</code> .	



It is necessary to define the arguments of the creation services. To do this, the analyst uses the fields of the message structures. Data fields derive data-valued inbound arguments (see rule **OM19**), whereas reference fields derive object-valued inbound arguments (see rule **OM20**).

Rule OM19. Add data-valued inbound arguments	
Preconditions	
	Rule OM18 has already applied.
Textual explanation	
1	For each creation service, add a data-valued inbound argument for each data field contained in the complex substructure that has led to the derivation of the service.
2	The analyst can freely decide the name of the data-valued inbound argument, although it is recommended to give it the name p_atrdatafield (i. e., the data field name with the prefix p_atr)
3	The properties of the data-valued inbound arguments coincide with the properties of their corresponding attributes. This means that the data type, size and compulsory are the same that were specified when the properties of the attributes were defined.
Example	
For instance, the data field Treatment number has led to the derivation of the attribute treatment_number (by applying the rule OM6). Now it leads to the derivation of a data-valued argument named p_atrtreatment_number, which is added to the creation service new_medical_treatment.	
The arguments and their properties are specified in Table 6. Notice that its properties are the same that its corresponding attributes (see Table 4)	

Rule OM20. Add object-valued inbound arguments	
Preconditions	
	Rule OM19 has already been applied.
Textual explanation	
1	For each creation service, add an object-valued inbound argument for each reference field contained in the complex substructure that has led to the derivation of the service.
2	The properties of the object-valued inbound arguments are derived as follows. Take into account that the reference field has led to the derivation of a structural relationship (see rule OM16) and a minimum cardinality on the side of the referenced class has been defined (see rule OM17 , step 2).
3	The argument data type is the referenced class.
4	If the minimum cardinality on the side of the referenced class is 0 then the property Null allowed of the argument is set to “yes”, else (if it is 1) the property Null allowed of the argument is set to “no”.
Example	
For instance, the reference field Patient has led to the derivation of a structural relationship between classes <code>MEDICAL_TREATMENT</code> and <code>PATIENT</code> . Now it leads to the derivation of an object-valued argument named <code>p_agrPatient</code> , which is added to the service <code>new_medical_treatment</code> . This attribute defines the patient for who the medical treatment is prescribed. The data-type of the argument is the class <code>PATIENT</code> . Since the minimum cardinality of the above-mentioned structural relationship on the side of class <code>PATIENT</code> is 1 (see Figure 13) then the inbound argument does not allow null values.	
The arguments and their properties are specified in Table 6.	

Table 6 shows the derived inbound arguments and their properties¹⁰.

Table 6. Specification of inbound arguments of service `new_medical_treatment`

Argument name	Data type	Size	Null allowed
<code>p_atrtreatment_number</code>	Autonumeric	-	no
<code>p_atrinitial_date</code>	Date	-	no
<code>p_atrfinal_date</code>	Date	-	no
<code>p_atrcomments</code>	String	200	yes
<code>p_agrPatient</code>	Patient	-	no

When the class diagram view corresponds to a complex business object, then apart from the creation service for each of its constituent classes another service needs to be added to the *main* class of the business object (see rule **OM21**). We refer to this kind of service as end-of-editing service because, by means of executing it, the user indicates that s/he has finished editing the message corresponding to the communicative event and that the information system reaction should be triggered.

¹⁰ Prefixes in the argument names follow **OLIVANOVA** naming conventions.

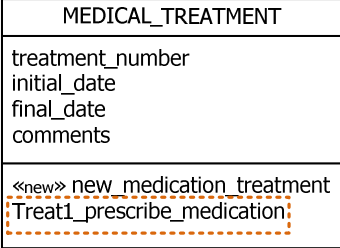
Rule OM21. Add an end-of-editing service for complex business objects	
Preconditions	
	Rule OM5 executed.
Textual explanation	
1	Add a service to each class that corresponds to a complex substructure and this corresponds to a complex business object.
2	The service name corresponds with the principal event lead a trigger event. The analyst can freely decide the name of the service, although it is recommended to give it the name event-id_name-of-the-event.
Example	
Therefore, a service named Treat1_prescribe_medication is added to the class MEDICAL_TREATMENT (see Figure 15). This service is triggered by the doctor whenever s/he has finished introducing the information. Only after this service is executed, the medical treatment is considered to be prescribed.	
 <pre> classDiagram class MEDICAL_TREATMENT { treatment_number initial_date final_date comments } class new_medication_treatment { Treat1_prescribe_medication } </pre>	
Figure 15. Class MEDICAL_TREATMENT with the service Treat1_prescribe_medication	

According to the OO-Method, every service that is not a creation service needs an object-valued inbound argument that represents the instance of the class for which the service is invoked (see rule **OM22**).

Rule OM22. Add inbound arguments to services that are not creation services.	
Preconditions	
	Rules OM21 has already been applied.
Textual explanation	
1	For each service that is not a creation service, add an inbound argument that represents the instance of the class for which the service is invoked.
2	Give the argument the name p_thisClassName (i.e. the class name with the prefix p_this). The argument data type is the class for which the service has been defined.
Example	
For instance, for the service Treat1_prescribe_medication, an inbound argument is p_thisMedicalTreatment. The argument data type is Medical_Treatment.	

As explained above, after a doctor prescribes a medical treatment (that is, communicative event *TREAT 1*), a nurse assigns the dispensary where the treatment will be provided, and she assigns the treatment delivery date (that is, *TREAT 2*). This way, *TREAT 2* affects the same business object that is affected by the precedent event; namely, the medical treatment. For this reason, by applying rule **OM2**, the reference field *Treatment* belonging to the message structure of *TREAT 2* that refers to the previously-prescribed medical treatment has been marked; that is, its *Extends business object* property (column) has been set to *True*. Whenever an aggregation substructure includes a reference field with such a mark, then we need to extend a previously-derived class with new attributes and/or structural relationships (see rule **OM23**).

Rule OM23. Extension of a class	
Preconditions	
	Rule OM5 has already applied.
Textual explanation	
1	For each aggregation substructure that contains a reference field whose property <i>Extends business object</i> is <i>True</i> , extend a previously-derived class.
2	To choose the class, first select the aggregation substructure that corresponds to the business object referenced by the reference field; it will belong to a precedent communicative event (otherwise there is either an invalidity in the precedence relationships or an error has been made during the event sorting, rule OM3). Then obtain the class that was derived from this aggregation substructure; to do this, simply follow the traceability link.
3	Each data field that is contained in the aggregation substructure leads to the derivation of a new attribute that is added to the extended class (see rule OM6).
4	Each reference field that is contained in the complex substructure and is not marked leads to the derivation of a new structural relationship between the class being extended and the class that corresponds to the reference field (the derivation of structural relationships and their cardinalities is explained in rules OM16 and OM17).
5	In any case, take into account that the minimum cardinality in the side of the referenced class is necessarily 0. The moment the instance is created this link is not created; it occurs later).
Example	
Figure 16 shows the specification of the message structure of communicative event <i>TREAT 2</i> . The reference field <i>Treatment</i> refers to a medical treatment and, since its property <i>Extends business object</i> is <i>True</i> , then the class that corresponds to this business object is extended; that is, <i>MEDICAL_TREATMENT</i> (Figure 16 depicts how to select the class).	
The data fields in the message structure lead to adding new attributes to the class (according to rule OM6); this way, the field <i>delivery_date</i> leads to adding an attribute named <i>delivery_date</i> to the class <i>MEDICAL_TREATMENT</i> . In turn, the reference fields lead to adding new structural relationships between the class and previously-derived classes; this way, the reference field <i>Dispensary</i> leads to adding a structural relationship between <i>MEDICAL_TREATMENT</i> and <i>DISPENSARY</i> (according to rule OM16).	

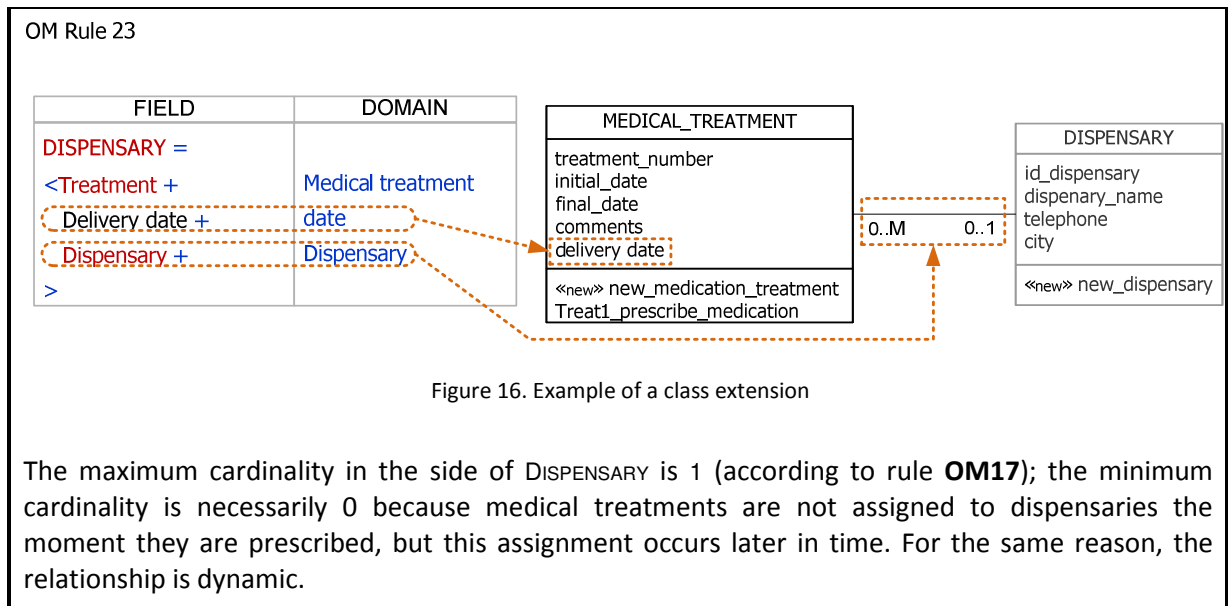

All the attributes that are added to a class as a result of a class extension should have their properties defined as explained in rule **OM24**.

Rule OM24. Attribute properties of extended classes	
Preconditions	
	Rule OM23 has already been applied.
Textual explanation	
1	The attributes are not part of the identification function.
2	The attribute type is Variable.
3	The attributes are not requested upon creation.
4	The attributes allow nulls.
5	The attributes data types are derived from the domain of the field (according to rule OM10).
Example	
According to the textual explanation, the properties of the attribute <code>delivery_date</code> are showed in Table 7.	

Table 7. Properties of the attribute `delivery_date`

Attr. name	Id	Attr. type	Data type	Size	Requested	Null allowed
<code>delivery_date</code>	no	Variable	date		no	yes

Whenever new attributes are added to an extended class, a service needs to be added in order to set their values (see rule **OM25**). According to the OO-Method, these attributes are said to be *own events* (a.k.a. edit events), what means that they are neither creation events nor destruction events.

Rule OM25. Add services to extended classes	
Preconditions	
	Rule OM24 has already been applied.
Textual explanation	
1	Add a service to the extended class in order to allow setting the values of the newly-added attributes.
2	If the class has been extended with just one attribute, then the service can be named <code>set_attribute_name</code> (i.e. the name of the attribute with the prefix <code>set_</code>). Else, select an appropriate name that represents all the information being provided.
4	For each structural relationship that has been derived during the extension of the class, add two shared services to the involved classes intended to add and to destroy links between instances (<code>ins_class_name</code> and <code>del_class_name</code> , respectively).
Example	
A service named <code>set_delivery_date</code> is added to the class to set the value for the newly-added attribute <code>delivery_date</code> . Furthermore, given the cardinality of the structural relationship, two shared services are included in both classes (this is prescribed by the OO-Method [7]); namely an insertion shared service named <code>ins_dispensary</code> and a deletion shared service named <code>del_dispensary</code> .	
<pre> classDiagram class MEDICAL_TREATMENT { treatment_number initial_date final_date comments delivery_date <<new>> new_medication_treatment Treat1_prescribe_medication set_delivery_date <<shared>><<int>> ins_dispensary <<shared>><<int>> del_dispensary } class DISPENSARY { id_dispensary dispensary_name telephone city <<new>> new_dispensary <<shared>><<int>> ins_dispensary <<shared>><<int>> del_dispensary } MEDICAL_TREATMENT "0..M" -- "0..1" DISPENSARY </pre>	
<p>Figure 17. Addition of set services and shared services to the classes MEDICAL_TREATMENT and DISPENSARY</p>	

When the reaction to a communicative event requires the execution of several services of the same class, then a transaction is created in order to ensure their atomic execution (see rule **OM26**). The rationale for creating such a transaction is that it is not a good practice to delegate to the user of the software application the responsibility of executing all the needed services one after another; it is safer to encapsulate all of them in a transaction.

Rule OM26. Creation of transactions	
Preconditions	
	Rule OM25 has already been applied.
Textual explanation	
1	Create a transaction when is necessary to execute several services atomically. Whenever several services are defined for a class as a result of the processing of a single communicative event (they will often be an event to set the value of attributes and one or several insertion shared events to create links with other instances), then a transaction needs to

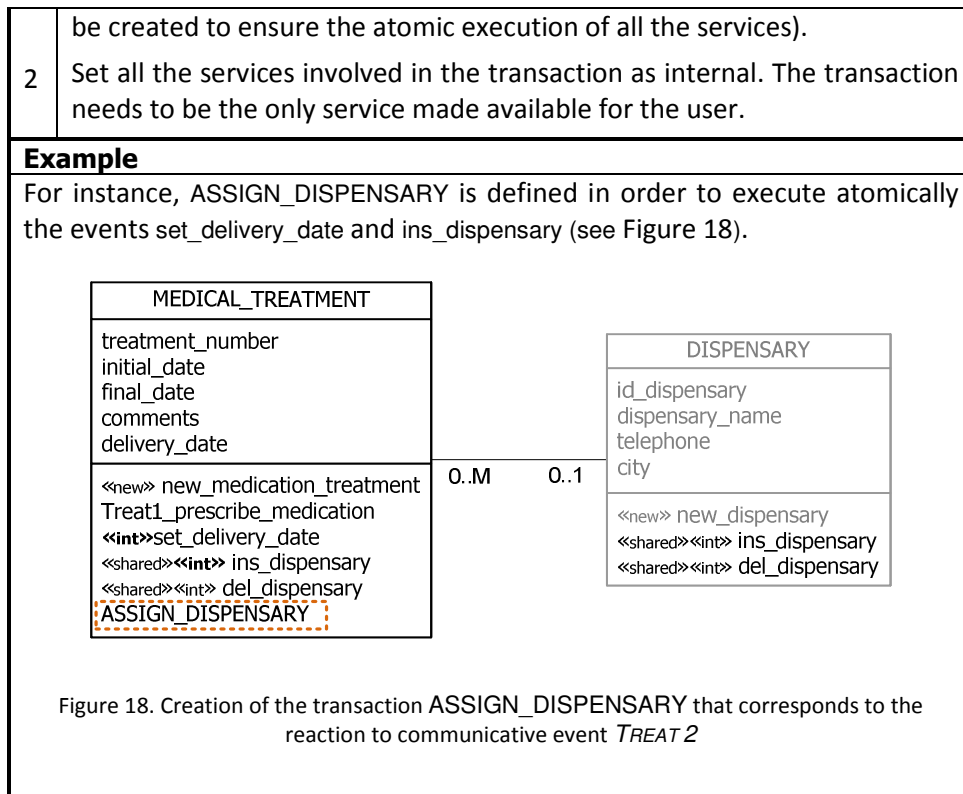

Figure 19 shows the class diagram (Object Model) that results from processing the events Treat 1, Treat 2 and its predecessors

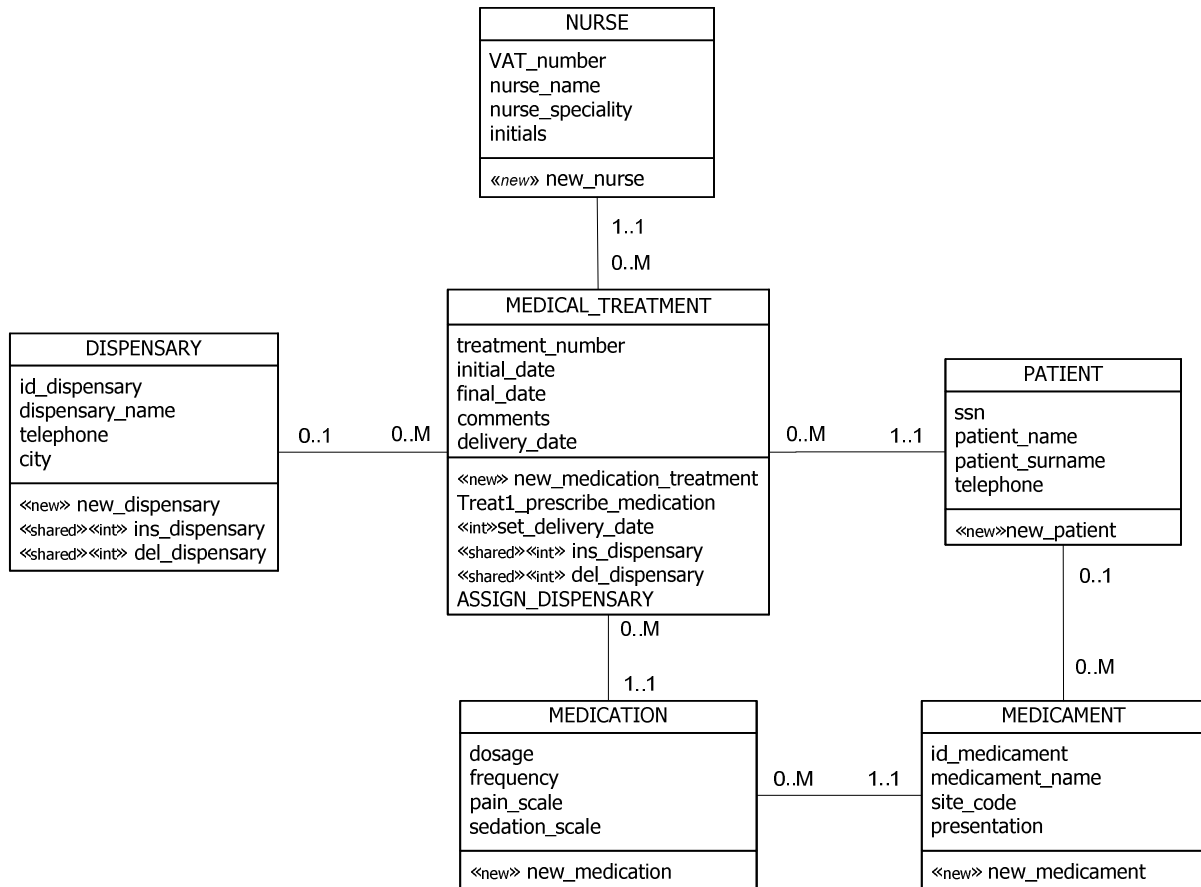

Figure 19. Class diagram obtained processing all the events in the example.

3. DERIVATION OF THE DYNAMIC MODEL

3.1. Derivation Strategy

We first present an overview of the derivation strategy (see Figure 1); with regards to the Dynamic Model, for each class of an Object Model, a state transition diagram (STD) is derived. The main input artefact for this derivation is the Communicative Event Diagram (See Figure 20.b). Roughly speaking communicative events are converted into transitions (e.g. IV, II) and precedence relationships are converted into states (e.g. IVED, IIED). Additional transitions can be added to the state transition diagram; for instance, transitions that correspond to edition and destruction atomic services, as well as transitions that corresponds to services that take part in a transaction.

To increase the comprehensibility of the examples, precedence relations and transitions have been labelled with a name that is derived from the name of the precedent event. The English participle suffix *-ed* is added to the event name. This intuitively represents the state in which an object remains after an event. For instance, after an occurrence of the event IV the affected object remains in the state IVED.

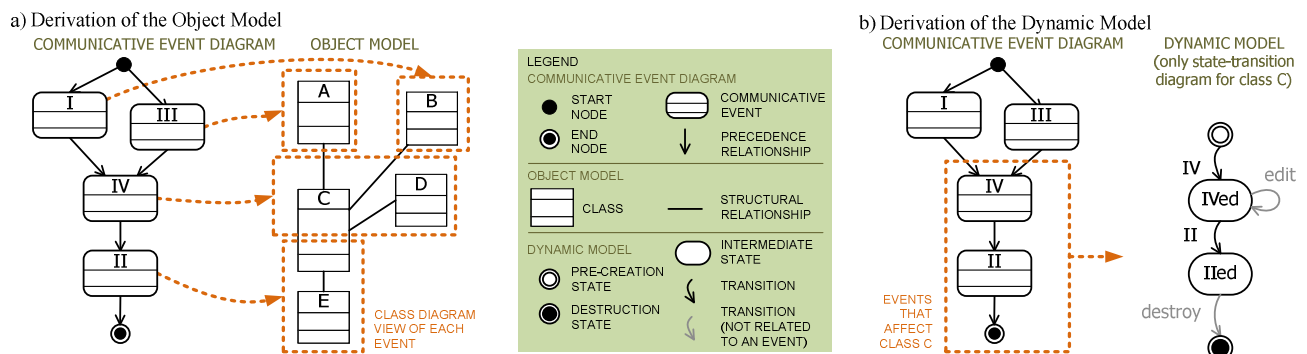

Figure 20. Simplified example of the derivation of the structural and behavioural views of the conceptual model

3.2. Derivation Guidelines

The first step is to obtain, for each class in the Object Model, a sub-diagram that contains only the communicative events that affect the given class is obtained (see Rule **DM1**). The derivation of the Object Model from the requirements model also produces traceability mappings that specify which classes have been created or extended by which communicative events; thus, obtaining the sub-diagram is straightforward.

Rule DM1 . Production of the sub-diagram for class C	
Preconditions	
	None
Textual explanation	
1	Duplicate the communicative event diagram.
2	Remove every communicative event for which there is no traceability mapping to class C.
3	Remove any loopbacks (if any).
4	Add a start node to the CED (if it does not already exist).
5	For each initial communicative event, add a precedence relation that departs from the start node and arrives at the event (if the relation

does not already exist).
(End nodes and their corresponding precedence relations are not needed for derivation purposes, but they do not need to be removed.)

Example

Following the previous example (see Figure 1), the communicative events that affect a class C are identified and the sub-diagram is produced.

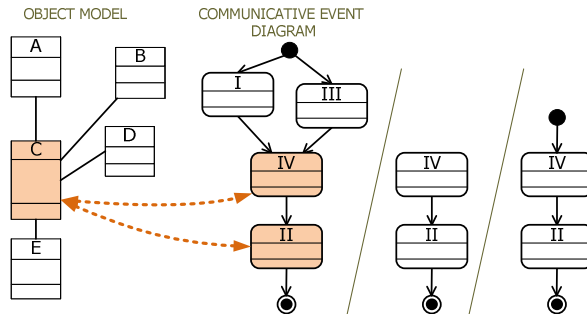

Figure 21. Sub-diagram corresponding to class C (from example in Figure 1)

Then an empty STD is created and a pre-creation state is added (see rule **DM2**).

Rule DM2. Initialisation of the STD

Preconditions

- 1 The CED has a start node (referred as n).

Textual explanation

- 1 Create an empty STD.
- 2 Add a pre-creation state to the STD.
- 3 Add a traceability link between the start node and the newly-created state.

Pseudocode

- 1 `std = std.new()`
- 2 `s = state.new()`
`s.name="Pre_creation"`
`s.type="pre_creation"`
- 3 `n.trace_state.add(s)`

Example



Figure 22. Examples of transformation of a start node

Rules **DM2**, **DM3** and **DM4** are the main derivation guidelines that produce intermediate states and transitions. Rule **DM2** accounts for communicative events that are not specialised and that do not have and-joins in their incoming precedence relations.

Rule DM2. Transformation of a communicative event A	
Preconditions	
1	All the precedent events of e A have already been processed (For all pe
2	in precedents(e), Exists t in event2state, t.event=pe) A has only one precedent event or all the precedences are composed in an or-merge.
Textual explanation	
1	Add a state to the STD and label it with the identifier of the event plus the suffix -ed (e.g. given an event identifier A, the state label is Aed).
2	Else, for each communicative event P that is a precedent of A, add a transition to the STD; the transition departs from the state that is traced to the precedent event and it arrives to the newly-added state.
3	Map the newly-added transitions to the class service that corresponds to the communicative event A. The service name should appear in the transition label.
4	Add the names of the agent classes that correspond to the support actor of A to the list of agents of the newly-added transitions.
5	Add a traceability link between the communicative event and the newly-added transitions as well as between the communicative event and the newly-created state.
Pseudocode	
1	s = state.new() s.name= e.name+"ed" s.type="intermediate"
2	For each pe in e.precedents do t = transition.new() t.initial_state= pe.trace_state -- podría haber varios! t.end_state=s
3	t.service=e.trace_service -- podría haber varios! -- e.trace_service was linked while deriving the Object Model -- (poner como pies de página, uno para todos los casos?)
4	For each ag in e.supports.actor.trace_agent_class t.agent_class.add(ag)
5	e.trace_transition.add(t) e.trace_state.add(s)
Example	

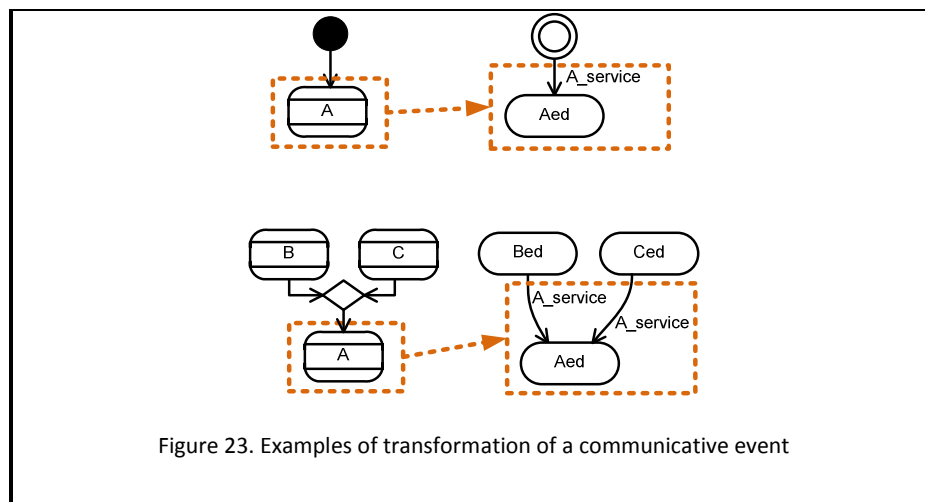

Figure 23. Examples of transformation of a communicative event

Rule **DM3** accounts for specialised communicative events. This leads to different paths in the STD.

Rule DM3. Transformation of a specialized communicative event A e

Preconditions

- 1 All the precedent events of communicative event A have already been processed.
- 2 A only has one precedent event or all the precedences are composed in an or-merge.

Textual explanation

- 1 For each event variant of the specialized communicative event, add a state to the STD and label it with the identifier of the variant plus the suffix -ed (e.g. A1ed, A2ed).
- 2 Add a traceability link between
- 3 For each communicative event P that is a precedent of A do
 - 3 For each event variant Ai of the specialized communicative event, add a transition to the STD; the transition departs from the state that corresponds to the precedent communicative event (or to the pre-creation state, in case A is an initial event) and it arrives at the state that corresponds to the variant.
- 4 Map the newly-added transitions to the class service that corresponds to the communicative event A. Also, add a control condition to each transition; the condition is derived from the specialisation condition that corresponds to the event variant (instead of message structure fields, their corresponding class arguments are used).
- 5 Add a default message to each newly-added transitions (this message will be displayed to the user if the transition cannot be executed).
- 6 Both the service name and the condition should appear in the transition label, as prescribed by the OO-Method: *service_name when condition*
- 7 Add the names of the agent classes that correspond to the support actor of A to the list of agents of the newly-added transitions.
- 7 Add a traceability link between the event variants and the newly-added transitions, and between the event variants and their corresponding,

8	newly-created states. Idem for the specialised communicative event.
Pseudocode	
1	For each v in e.variants do s=state.new() s.name= v.name+“ed” s.type=“intermediate”
2	e.trace_state.add(s)
3	For each pe in e.precedents do For each v in e.variants do t = transition.new() t.initial_state= pe.trace_state -- podría haber varios! t.end_state=v.trace_state -- idem
4	t.service=e.trace_service -- idem -- este es solucionable si se diferencia el servicio de fin de edición c=control_condition.new() c.formula=from_field_to_attributes(v.condition) -- definirla inform.
5	t.message=“This action cannot be executed” -- default message
6	-- displaying the transition label is a duty of the diagramming tool
7	For each ag in e.supports.actor.trace_agent_class t.agent_class.add(ag)
8	v.trace_transition.add(t) v.trace_state.add(s) e.trace_transition.add(t) e.trace_state.add(s)
Example	
<p>The diagram illustrates the transformation of a specialised communicative event. On the left, a state B is shown with a transition A leading to two states, A1 and A2. On the right, the transformed state Bed is shown with two transitions, both labeled A_service, leading to states A1ed and A2ed. The transition to A1ed is labeled 'when A1_condition' and the transition to A2ed is labeled 'when A2_condition'. A dashed orange box highlights the transformation area.</p>	
Figure 24. Example of transformation of a specialised communicative event	

Rule **DM4** accounts for and-joins. This implies the creation of auxiliary states that constitute a logical network.

Rule DM4. Transformation of an and-join over a communicative event A	
Preconditions	
1	All the precedent events of A have already been processed.
2	A has two or more precedent events and all the precedences are composed in an and-join.

Textual explanation

- 1 Add a state to the STD and label it with the identifier of the communicative event plus the suffix -ed (e.g. Aed).
Then a logical network is created and later simplified as follows.
- 2 All the allowed sequences of events are enumerated as columns in a matrix. In each row a communicative event is appended in a way that each matrix cell contains the set of events that have occurred in that particular sequence.
Links from one cell to another indicate the event that occurs.
- 3 The matrix is simplified by joining those sets that are equal (i.e. disregarding the order in which the events occur). The corresponding links are redirected to the new destination. The last row will always be simplified to a single cell.
- 4 For each cell in the matrix derive one state in the STD (if the state does not exist yet). Cells that have been joined lead to adding auxiliary states to the STD that support the logical network.
For each links between cells in the matrix derive a transition in the STD (if the transition does not exist yet).
- 5 Map each transition to the class service that corresponds to the communicative event in the link from where it has been derived. The service name should appear in the transition label.
- 6 For each transition, identify the support actors of the event in the link from where it has been derived.
- 7 Add the names of the agent classes that correspond to the support actors to the list of agents of the transition.
- 8 Add a transition to the STD; the transition departs from the last state of the logical network and it arrives at the state that has been created in step 1 of this rule.
- 9

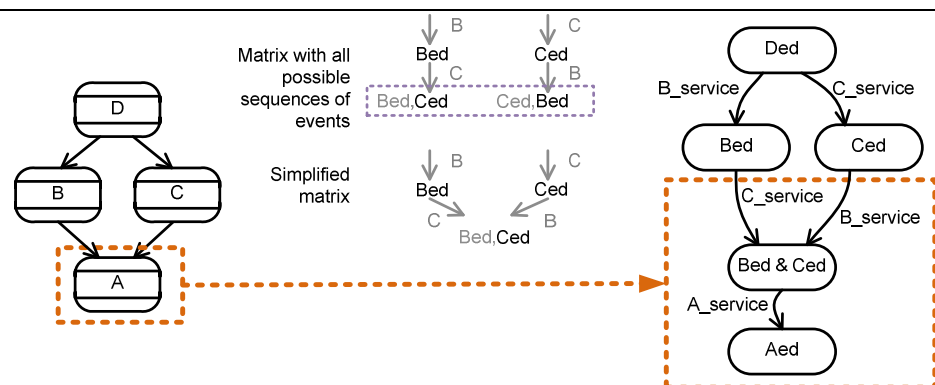
Example

Figure 25. Example of transformation of an and-join

4. REFERENCES

- [1] S. España, A. González, Ó. Pastor, and M. Ruiz, "Integration of Communication Analysis and the OO-Method: Manual derivation of the conceptual model. The SuperStationery Co. lab demo." Departamento de Sistemas Informáticos y Computación, Universidad Politécnica de Valencia, Spain, Available at <http://hci.dsic.upv.es/ca/SuperStationery-TR-v2.0.pdf> 2011.
- [2] A. González, S. España, M. Ruiz, and O. Pastor, "Systematic derivation of class diagrams from communication-oriented business process models." In: Business Process Modeling, Development, and Support (BPMDS'11 Working conference), London, England, 2011.
- [3] S. España, M. Ruiz, A. González, and O. Pastor, "Systematic derivation of state machines from communication-oriented business process models Derivation of the dynamic view of conceptual models in an industrial model-driven development method." In: Fifth IEEE International Conference on Research Challenges in Informatic Science (RCIS'11), Guadeloupe, France, 2011.
- [4] BatiniC., Lenzerini M., and Navathe S. B., "A comparative analysis of methodologies for database schema integration," *ACM Computing Surveys (CSUR)*, vol. 18, pp. 323-364, 1986.
- [5] Henderson J. C. and Venkatraman N., "Strategic alignment: leveraging information technology for transforming organizations," *IBM Systems Journal*, vol. 38, pp. 472-484, 1999.
- [6] Kahn A.B. (1962) Topological sorting of large networks. *Communications of the ACM*. 558-562.
- [7] O. Pastor and J. C. Molina, *Model-Driven Architecture in practice: a software production environment based on conceptual modeling*. New York: Springer, 2007.