

# Universal Communication over Modulo-additive Individual Noise Sequence Channels

Yuval Lomnitz, Meir Feder  
 Tel Aviv University, Dept. of EE-Systems  
 Email: {yuvall,meir}@eng.tau.ac.il

**Abstract**—Which communication rates can be attained over a channel whose output is an unknown (possibly stochastic) function of the input that may vary arbitrarily in time with no a-priori model? Following the spirit of the finite-state compressibility of a sequence defined by Lempel and Ziv, a “capacity” is defined for such a channel as the highest rate achievable by a designer knowing the particular relation that indeed exists between the input and output for all times, yet is constrained to use a fixed finite-length block communication scheme (i.e., use the same scheme over each block). In the case of the binary modulo additive channel, where the output sequence is obtained by modulo addition of an unknown individual sequence to the input sequence, this capacity is upper bounded by  $1 - \rho$  where  $\rho$  is the finite state compressibility of the noise sequence. A communication scheme with feedback that attains this rate universally without prior knowledge of the noise sequence is presented.

## I. INTRODUCTION

Consider the problem of communicating over a channel, where the (possibly stochastic) relation between the input and output is unknown to the transmitter and the receiver and may be, in general, non stationary. In particular, no assumption is made that the channel behavior up to a certain point in time indicates anything about its expected behavior from this time on. The key characteristic of such a channel is that the channel law cannot be learned, i.e. it is impossible, using an asymptotically short measurement period, to obtain the channel probability law and use it during the rest of the transmission.

Clearly, communication over such an arbitrary channel is challenging. Furthermore, even the question what the limits of such communication are, is not well posed. To emphasize the fact that the relation between input and output is a function of the entire sequences (or vectors) this channel shall be termed a *vector* channel. A simple example of such a channel, which was discussed by Shayevitz and Feder [1] is the modulo-additive channel with an individual noise sequence, defined by the relation  $\mathbf{y} = \mathbf{x} + \mathbf{z}$  where  $\mathbf{x}, \mathbf{y}, \mathbf{z} \in \mathcal{X}^n$  are  $n$ -length vectors, denoting the input, output and the noise sequence,  $\mathcal{X}$  is a finite alphabet, the ‘+’ denotes modulo addition over  $\mathcal{X}$ , and the sequence  $\mathbf{z}$  is arbitrary and unknown. The main focus in the current paper is on this channel model. When the alphabet is  $\mathcal{X} = \{0, 1\}$  this channel is referred to as the binary additive channel.

In the general vector channel, when the conditional probability of the output vector given the input vector is known, the classical Shannon capacity, i.e. the maximum communication

rate achievable with an arbitrarily small error probability, is well defined. The Shannon capacity of the general causal vector channel was given by Han and Verdú [2]. When the channel is unknown, the Shannon capacity of the known channel is in many cases not attainable universally. In this case, the compound channel or arbitrarily varying channel (AVC) frameworks [3] may be used. In these frameworks, the capacity is defined as the maximum rate of transmission which guarantees robust communication over all possible channels. However these frameworks do not consider the ability to use feedback to adjust the communication parameters, and are therefore worst-case in nature. On the other hand, Shayevitz and Feder [1] have shown that for the modulo-additive channel with an individual noise sequence, by using feedback to adapt the transmission rate to the actual channel occurrence, these worst case assumptions may be alleviated. These results were extended by us and other authors [4], [5].

Since the channel is unknown, the target is to find a universal communication system that operates without knowing the channel. While there are known universal source encoders [6] and universal predictors [7], in the communication problem, the term “universality” had been used mainly with respect to decoders (competing against the maximum likelihood decoder in a compound channel [3], [8]), and there is currently no notion of universality with respect to the complete communication system. This is since in the traditional AVC model, feedback is not considered and therefore the encoder is assumed to be fixed. On the other hand, in existing works that consider adaptation of the communication rate using feedback [1], [4], [5], the communication rates achieved do not have a strong justification. For example, these works define the rate using 0-order empirical distributions, and higher rates could be attained by considering empirical distributions with memory.

Let us denote by  $P_{\mathbf{y}|\mathbf{x}}^{(\theta)}$  a conditional distribution of the channel output given the input defining a vector channel, where  $\theta$  is an index belonging to a (possibly infinite) index set  $\Theta$ . Given a class of vector channels  $\{P_{\mathbf{y}|\mathbf{x}}^{(\theta)}\}_{\theta \in \Theta}$ , the objective is to assign a rate  $C_\theta$  to each channel, such that on one hand  $C_\theta$  has an operational meaning, for example the maximum rate achievable in a certain situation, and on the other hand, it would be possible to construct a universal system using feedback, that without knowledge of  $\theta$ , attains a rate of at least  $C_\theta$  for all  $\theta$ . The difference from the AVC or compound channel models is that the communication rate depends on  $\theta$ . As shall be seen, the maximum rate achievable by block

encoders and decoders is a reasonable target, that at least for the class of modulo-additive channels is universally attainable. Note, however, that the system attaining this target rate is not in itself a block encoding system.

This paper contains two main contributions. The first is a definition of a target rate  $C_\theta = C_{\text{IFB}}(P_{Y|X}^{(\theta)})$  for any vector channel, which is termed the “iterated finite block capacity”, and highlight some of its important properties. The other contribution is specific to the modulo-additive channel with an individual noise sequence, for a universal system that attains this target rate without knowing the channel is presented. The paper is organized as follows: in Section II the motivation for the definition of  $C_{\text{IFB}}$  are explained. Section III is a high level overview of the results regarding the modulo-additive channel, and the main ideas behind the proofs. Section IV includes the detailed definitions with some discussion. Section V focuses on the modulo additive channel and includes the upper bound on  $C_{\text{IFB}}$  and the universal system achieving it. The redundancy, i.e. the convergence rate, in achieving the IFB capacity is explored in Section VI. Section VII is devoted to discussion and comments and suggests some extensions and alternative definitions.

## II. MOTIVATION

Let us now discuss the motivations for the definitions of a target rate which is universally achievable. The inherent difficulty of defining the maximal communication rates over arbitrary vector channels can be appreciated by considering even the simple example of a binary additive channel  $\mathbf{y} = \mathbf{x} \oplus \mathbf{z}$  with an individual noise sequence  $\mathbf{z}$ , where ‘ $\oplus$ ’ denotes modulo-2 addition. For every specific individual noise sequence  $\mathbf{z}$ , the capacity of this channel is 1 bit/use. On the other hand, if the noise sequence is arbitrary and unknown the AVC capacity [3] is zero. It would initially seem that nothing much can be done, when the noise sequence is unknown; however it was shown [1] that using feedback and common randomness, and by adapting the decoding rate, a communication rate of  $R = 1 - \hat{H}(\mathbf{z})$  could be achieved, where  $\hat{H}(\cdot)$  denotes the empirical entropy of the noise sequence (the binary entropy of the empirical cross-over probability). The main idea is that if the empirical channel can be measured and the communication rate can be adapted, then rather than making a-priori pessimistic assumptions, one can opportunistically increase the rate when the noise sequence has a low empirical entropy.

A disturbing fact is that some arbitrariness exists in deciding on the rates to achieve per each channel: in the binary additive channel, given a sequence  $\mathbf{s}$  of choice, one could also design a system that achieves the rate  $1 - \hat{H}(\mathbf{z} \oplus \mathbf{s})$ , by adding the sequence  $\mathbf{s}$  to the channel output and then applying Shayevitz and Feder’s scheme [1]. Doing so, a rate of 1 is obtained for the sequence  $\mathbf{z} = \mathbf{s}$ , where in the original system the rate was  $1 - \hat{H}(\mathbf{s})$ , and a rate of  $1 - \hat{H}(\mathbf{s})$  for the noiseless case  $\mathbf{z} = \mathbf{0}$ , so we may say the noise sequence  $\mathbf{s}$  is “favored” over  $\mathbf{0}$ . This demonstrates the arbitrariness in determining which communication rates are possible. To remove this arbitrariness, a reasonable criterion is sought, to decide which channels (noise sequences, in the example) to favor over others.

This issue bears significant resemblance to issues tackled in universal source coding (compression) and in universal prediction. In universal compression, one would like to set a target for the compression rate of an individual sequence. As in our problem, someone who knows the sequence can design an encoder which compresses it to 1 bit, whereas assuming the sequence is completely unknown and without favoring any sequence over another, no compression can be achieved. There are many possible fixed to variable encoders which are uniquely decodable, and the decision between them may seem arbitrary. One solution proposed by Lempel and Ziv [6] was to set as a target the compression rates that are achievable by machines with limited capabilities, i.e. finite state machines (FSM). They defined the notion of *finite state compressibility* for an infinite sequence, as the best compression rate that can be achieved by any information lossless FSM operating over the (infinite) sequence, and had shown that the LZ78 compression algorithm based on incremental parsing (defined there), achieves this compression rate universally for any sequence. This concept supplies a criterion to decide which sequences to favor over others, without assuming a probability law. A similar notion, i.e. that of comparing against the best machine out of a restricted class, is applied in universal prediction [7], [9].

Following this lead the comparison class is chosen to be the set of fixed finite-length block encoders and decoders, which repeatedly perform the same encoding and decoding operations over blocks of any fixed length (Figure 2). This class is a relatively simple one, while still yielding a reasonable criterion to set the communication rate. The *iterated finite block capacity* of an infinite vector channel  $C_{\text{IFB}}$  is defined as the supremum of all rates which are reliably achievable by encoders and decoders in the comparison class. This capacity value is smaller, in general, than the Shannon capacity of the vector channel. This definition has operational significance, since many practical communication systems use block encoding, and therefore universally attaining the  $C_{\text{IFB}}$  means that one can design a system which, without any prior knowledge of the channel, is essentially at least as good as any system using block coding of any finite length. The universal system itself does not belong to the comparison class – it does not operate in fixed blocks, it modifies its behavior based on the past, and it uses feedback. There are various ways to extend the comparison class, which are briefly discussed in Section VII, however, here the focus on this basic model. Although achieving  $C_{\text{IFB}}$  universally is possible for classes of vector channels wider than the modulo-additive channel [10], it is not possible to attain this rate for general unknown vector channels.

## III. OVERVIEW OF THE MAIN RESULTS

This section provides an informal review of the main results and rough proof outlines. The purpose is to provide an understanding of the results without diving into mathematical detail. The main results of this paper pertain to the modulo-additive channel with individual noise sequence. For this channel, it is shown in Section V that  $C_{\text{IFB}} \leq (1 - \rho(\mathbf{z})) \cdot \log |\mathcal{X}|$ , where

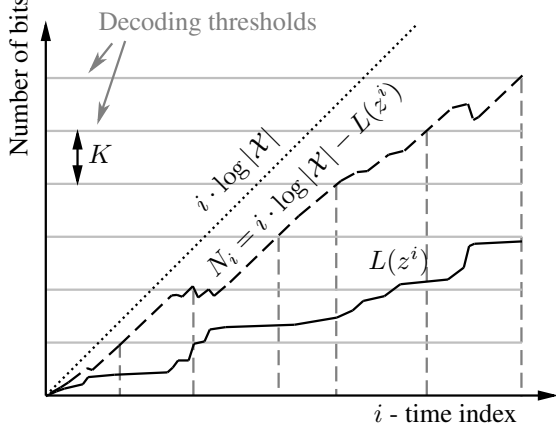

Fig. 1. Illustration of the decoding rule of the rate adaptive system.  $L(z^i)$  is the compression length. Decoding thresholds with respect to  $N_i = i \cdot \log |\mathcal{X}| - L(z^i)$  are depicted by horizontal lines.

$\rho(\mathbf{z})$  is the finite state compressibility of  $\mathbf{z}$  (as defined by Lempel and Ziv [6]). Assuming that common randomness exists and that there is a feedback link, a universal system employing feedback exists, which asymptotically attains this rate universally without prior knowledge of the noise sequence. In Section VI, upper and lower bounds on the convergence rate are derived. Below the main ideas in the proofs are described.

Let us begin with the upper bound on  $C_{\text{IFB}}$ . Suppose a given encoder and decoder (the reference system) achieves rate  $R$  over  $b$  blocks of size  $k$  (Figure 2). During these  $b$  blocks, the reference system “sees”  $b$  different noise vectors of length  $k$ , namely  $\mathbf{z}_{(i-1)k+1}^{ik}$ ,  $i = 1, \dots, b$ . Since the system is fixed during these  $b$  blocks, this is equivalent to operating over a stochastic channel, where the noise vector  $\tilde{\mathbf{Z}}$  is chosen uniformly from the set of these vectors, with probability  $\frac{1}{b}$  for each. This random vector is termed the “collapsed” noise sequence, and the channel generated from it the “collapsed” channel. The standard converse of the channel capacity theorem (without the assumption of a memoryless channel) can be applied to the collapsed channel (Figure 5), and yields an upper bound on  $C_{\text{IFB}}$  which is roughly  $\log |\mathcal{X}| - \frac{1}{k} H(\tilde{\mathbf{Z}})$ . The entropy  $H(\tilde{\mathbf{Z}})$  is lower bounded using the finite state compressibility of the sequence, since a finite state machine may achieve a compression rate close to the entropy by standard block-to-variable coding, where the code lengths are tuned to the statistics of the collapsed noise vector. Combining these bounds yields the result  $C_{\text{IFB}} \leq (1 - \rho(\mathbf{z})) \cdot \log |\mathcal{X}|$  (Theorem 1).

Next, a communication scheme is demonstrated, that asymptotically attains the rate  $\log |\mathcal{X}| - \frac{1}{n} L(\mathbf{z})$ , where  $L(\mathbf{z})$  is the compression length of the sequence  $\mathbf{z}$  by a given sequential source encoder, and  $n$  is the overall block length. The scheme is based on iterative application of rateless coding, sending  $K$  bits in each block. Each codeword in the codebook of  $\exp(K)$  words is chosen independently and distributed uniformly over  $\mathcal{X}^n$ . The transmitter sends symbols from the codeword matching the  $K$  transmitted bits, until a termination

condition occurs on the receiver side. Then, the receiver indicates the end of the block through the feedback link and a new block begins. The termination condition is based on feeding into the source encoder the sequence of noise which is known in high probability from previous blocks that had been decoded (since both the channel input and the channel output are known), and then, for each of the  $\exp(K)$  hypotheses regarding the codeword sent in the current block, continuing this sequence with the hypothetical noise sequence (formed by the known output and hypothetical input), to form an hypothesis for the noise sequence from the beginning of transmission to the end of the current block  $\hat{\mathbf{z}}_1^i$ . For each hypothesis, the decoder counts the number of bits that reflect the compression of the noise sequence in the the current block, and terminates the block if for any codeword, this length is smaller than a threshold.

The proof of this scheme’s performance is roughly as follows. Due to the random coding, most of the hypotheses (except the true one) yield random noise sequences. These sequences are incompressible, and therefore the number of bits representing the last block would be approximately  $\log |\mathcal{X}|$  times the number of symbols in the block. It can be shown that setting the threshold approximately  $K$  below this value, guarantees a small probability of exceeding the threshold for any of the  $\approx \exp(K)$  incorrect codewords, and therefore a small probability of error. It is convenient to define the “incompressibility” of the sequence up to time  $i$  as  $N_i = i \cdot \log |\mathcal{X}| - L(\hat{\mathbf{z}}_1^i)$ , representing the gap between the compressibility of the hypothetical noise sequence, and the compressibility of a random sequence. The approximate termination condition may be interpreted as decoding when the value of  $N_i$  increases by  $K$  from the start of the current block. Since when this occurs, the system starts a new block, there is a correspondence between the increase in  $N_i$  and the number of blocks and bits that are transmitted, i.e. the termination condition can be approximately interpreted as  $N_i \geq K(b+1)$  where  $b$  is the number of blocks so far. Therefore assuming by time  $n$ ,  $B$  blocks were transmitted, the number of transmitted bits is  $K \cdot B \approx N_n = n \cdot \log |\mathcal{X}| - L(\hat{\mathbf{z}}_1^n)$ . Assuming no errors occurred  $\hat{\mathbf{z}}_1^n = \mathbf{z}_1^n$ , and dividing by  $n$  the desired result is obtained. This is depicted in Figure 1, where the horizontal axis is the time  $i$ . The solid line presents  $L(\mathbf{z}_1^i)$ , and the dashed line  $N_i$ . The decoding thresholds  $Kb$  ( $b = 1, 2, \dots$ ) are depicted as horizontal lines, while the vertical lines depict the decoding times. It A decoding occurs whenever  $N_i$  crossed a threshold. A random hypothesized sequence in the current block implies that  $N_i$  does not increase on average. It can be seen that the number of bits that will be sent is approximately  $N_n$ . In the full proof, various overheads that were neglected above are accounted for.

To obtain the universal system attaining  $C_{\text{IFB}}$  (Theorem 2), the scheme above is applied with the encoding lengths  $L(\mathbf{z})$  determined by the LZ78 source encoder, whose compression ratios asymptotically approach the finite state compressibility: asymptotically  $L(\mathbf{z}) \leq \rho(\mathbf{z}) \log |\mathcal{X}|$ , therefore  $\log |\mathcal{X}| - \frac{1}{n} L(\mathbf{z}) \geq (1 - \rho(\mathbf{z})) \log |\mathcal{X}|$  (where all inequalities are up to asymptotically vanishing factors).

Section VI deals with the question of redundancy, or how

fast the system converges to the rate attained by the IFB system with a given block length  $k$ . Unfortunately, it is shown that  $n$  must grow at least as fast as  $|\mathcal{X}|^k$ , approximately. The upper bound on redundancy is obtained by using a similar universal system employing a slightly more refined design: instead of using Lempel-Ziv compression algorithm to generate decoding metrics, a universal probability assignment based on a mixture of Krichevsky-Trofimov distributions [11] is used. The lower bound is obtained by presenting a design of an IFB system together with a random channel (i.e. a distribution over noise sequences), such that the mutual information over the channel is smaller than the rate obtained by the IFB system. This is possible because the IFB system is designed together with the channel and can use the knowledge of the specific noise sequence. On the other hand, the rate obtained by any universal system with feedback is bounded by the mutual information, and this gap comprises the lower bound on redundancy. Although the upper bound and lower bound on redundancy differ, they agree in terms of the asymptotical growth rate of  $n$  as function of  $k$ .

#### IV. CHANNEL MODEL AND DEFINITIONS

In this section we begin the formal presentation of the results, by presenting the channel model and the definitions of the capacity  $C_{\text{IFB}}$ , and discussing their implications.

##### A. Notation

Vectors are denoted by boldface letters. Sub-vectors are defined by superscripts and subscripts:  $\mathbf{x}_j^i \triangleq [x_j, x_{j+1}, \dots, x_i]$ .  $\mathbf{x}_j^i$  equals the empty string if  $i < j$ . The subscript is sometimes removed when it equals 1, i.e.  $\mathbf{x}^i \triangleq \mathbf{x}_1^i$ .

For a vector or random variable  $\mathbf{X}$ ,  $\mathbf{X}_i^{[k]} \triangleq \mathbf{X}_{(i-1)k+1}^{(i-1)k+k}$  denotes the  $i$ -th block of length  $k$  in the vector. For brevity, vectors with similar ranges are sometimes joined together, for example, the notation  $(\mathbf{X}\mathbf{Y})_1^k$  is used instead of  $\mathbf{X}_1^k \mathbf{Y}_1^k$ . Exponents and logs are base 2. Random variables are distinguished from their sample values by capital letters. We use the following notation for empirical distributions: for a list or vector  $A = (x_1, x_2, x_3, \dots)$ ,  $\hat{P}(A = x)$  denotes the relative number of occurrences of  $x$  within  $A$ . For example,  $\hat{P}(\mathbf{z} = 1) = \hat{P}((z_i)_{i=1}^n = 1)$  denotes the normalized number of '1'-s in  $\mathbf{z}$ .

##### B. Channel model

Let  $\mathbf{x}$  and  $\mathbf{y}$  be infinite sequences denoting the input and the output respectively, where each letter is chosen from the alphabets  $\mathcal{X}, \mathcal{Y}$  respectively,  $x_i \in \mathcal{X}, y_i \in \mathcal{Y}$ . Throughout the current paper the input and output alphabets are assumed to be finite. A channel  $P_{\mathbf{Y}|\mathbf{X}}$  is defined through the probabilistic relations  $P_{\mathbf{Y}|\mathbf{X}}(\mathbf{y}^n | \mathbf{x}^\infty) = \Pr(\mathbf{Y}^n = \mathbf{y}^n | \mathbf{X}^\infty = \mathbf{x}^\infty)$  for  $n = 1, 2, \dots, \infty$ . A finite length output sequence is considered in order to make the probability well defined. Sometimes, this probability will be informally referred to as  $\Pr(Y_1^\infty | X_1^\infty)$ , and should be understood as the sequence of the above distributions, or their limit for  $n \rightarrow \infty$ .

**Definition 1.** The channel defined by  $\Pr(Y_1^n | X_1^\infty)$  is termed *causal* if for all  $n$ :

$$\Pr(\mathbf{Y}_1^n | \mathbf{X}_1^\infty) = \Pr(\mathbf{Y}_1^n | \mathbf{X}_1^n). \quad (1)$$

All the definitions below (including IFB capacity) pertain to causal channels. This characterization of a causal channel is similar to the definition used by Han and Verdú [2] (and references therein). This definition is also limited in assuming the channel starts from a known state (at time 0). However this does not limit the current setting, because an arbitrary initial state can be modeled by considering the family of channels with all possible initial states. Note that non causality that consists of bounded negative delays can always be compensated by applying a delay to the output.

##### C. IFB capacity

The following definitions lead to the definition of IFB capacity .

**Definition 2** (Reference encoder and decoder). A finite length encoder  $E$  with block length  $k$  and a rate  $R$  is a mapping  $E : \{1, \dots, M\} \rightarrow \mathcal{X}^k$  from a set of  $M \geq \exp(kR)$  messages to a set of input sequences  $\mathcal{X}^k$ . A respective finite length decoder  $D$  is a mapping  $D : \mathcal{Y}^k \rightarrow \{1, \dots, M\}$  from the set of output sequences to the set of messages.

**Definition 3** (IFB error probability). The *average error probability in iterative mapping* of the  $k$  length encoder  $E$  and decoder  $D$  to  $b$  blocks over the channel  $P_{\mathbf{Y}|\mathbf{X}}$  is defined as follows:  $b$  messages  $\mathbf{m}_1, \dots, \mathbf{m}_b$  are chosen as i.i.d. uniformly distributed random variables  $\mathbf{m}_i \sim U\{1, \dots, M\}, i = 1, \dots, b$ . The channel input is set to  $\mathbf{X}_i^{[k]} = E(\mathbf{m}_i), i = 1, \dots, b$ , and the decoded message is  $\hat{\mathbf{m}}_i = D(\mathbf{Y}_i^{[k]})$  where  $\mathbf{Y}$  is the channel output. The iterative mapping is illustrated in Fig.2. The average error probability is  $P_e = \frac{1}{b} \sum_{i=1}^b \Pr(\hat{\mathbf{m}}_i \neq \mathbf{m}_i)$ .

**Definition 4** (IFB achievability). A rate  $R$  is *iterated-finite-block (IFB) achievable* over the channel  $P_{\mathbf{Y}|\mathbf{X}}$ , if for any  $\epsilon > 0$  there exist  $k, b^* > 0$  such that for any  $b > b^*$  there exist an encoder  $E$  and a decoder  $D$  with block length  $k$  and rate  $R$  for which the average error probability in iterative mapping of  $E, D$  to  $b$  blocks is at most  $\epsilon$ .

Note that this is equivalent to stating that the lim sup of the average error probability with respect to  $b$  is at most  $\epsilon$ .

**Definition 5** (IFB capacity). The *IFB capacity* of the channel  $P_{\mathbf{Y}|\mathbf{X}}$  is the supremum of the set of IFB achievable rates, and is denoted  $C_{\text{IFB}}$  .

##### D. Competitive Universality

In the following, the properties of the adaptive system with feedback, and IFB-universality are defined. A randomized rate-adaptive transmitter and receiver for block length  $n$  with feedback are defined as follows: the transmitter is presented with a message expressed by an infinite bit sequence, and following the reception of  $n$  symbols, the decoder announces the achieved rate  $R$ , and decodes the first  $\lceil nR \rceil$  bits. An error

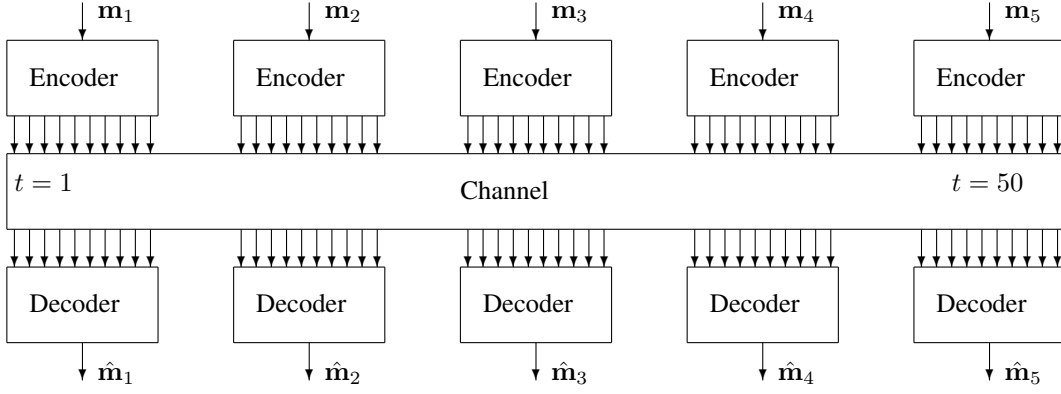

Fig. 2. An illustration of *iterative mapping* used for the definition of average error probability (see Definition 3). The same encoder and decoder are used over each of the  $b = 5$  blocks of  $k = 10$  channel uses, and the average error probability is computed.

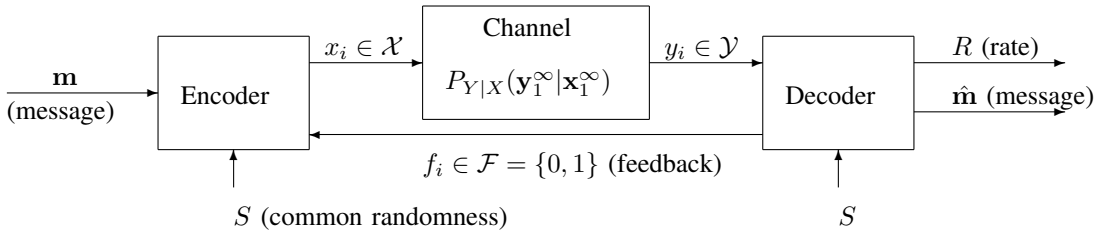

Fig. 3. Rate adaptive encoder-decoder pair with feedback

means any of these bits differs from the bits of the original message sequence. Both encoder and decoder have access to a random variable  $S$  (the common randomness) distributed over a chosen alphabet, and a causal feedback link allows the transmitted symbols to depend on previously sent feedback from the receiver. See formal definitions in our previous paper [5]. The system is illustrated in Fig. 3.

The following definition states formally the notion of IFB-universality for rate adaptive systems:

**Definition 6** (IFB universality). With respect to a set of channels  $\{P_{Y|X}^{(\theta)}\}$ ,  $\theta \in \Theta$  (not necessarily finite or countable), a rate-adaptive communication system (possibly using feedback and common randomness) is called *IFB universal* if for every channel in the family and any  $\epsilon, \delta > 0$  there is  $n$  large enough such that when the system is operated over  $n$  channel uses, then in probability  $1 - \epsilon$ , the message is correctly decoded and the rate is at least  $C_{\text{IFB}}(P_{Y|X}) - \delta$ .

#### E. A discussion on IFB capacity and universality

Following are some comments regarding IFB capacity and IFB universality. Note that the use of average error probability over time and messages (expressed in the assumed uniform distribution) rather than maximum error probability (over time or messages) reduces the requirements from  $E, D$  and therefore increases  $C_{\text{IFB}}$ .

As noted,  $C_{\text{IFB}} \leq C$ , where  $C$  is the Shannon capacity [2]. However for i.i.d. memoryless channels clearly  $C_{\text{IFB}} = C$ . The difference between  $C$  and  $C_{\text{IFB}}$  relates to the stability of the channel over time, and the ability to utilize channel

structure which cannot be observed in finite time. Let us give two examples to sharpen this difference:

**Example 1.** Consider the binary product channel  $y_i = x_i \cdot z_i$ , and let the sequence  $\mathbf{z}$  alternate between 0 and 1, in blocks of ever growing size, but such that the overall frequency of 0 is  $\frac{1}{2}$ , and the length of each blocks is negligible compared to the total length of previous blocks. For example, set  $z_i$  to 0 in  $i \in \cup_{k=1}^{\infty} [2k^2, (k+1)^2 + k^2]$ . For this channel  $C_{\text{IFB}} = 0$  while  $C = \frac{1}{2}$ . The reason is that for every finite length encoder/decoder, ultimately as  $m \rightarrow \infty$  half the blocks will fall on bursts of  $z = 0$  and be in error. Note that if rate adaptation would have been allowed at the IFB decoder, this capacity would not have been zero (see Section VII-A)

**Example 2.** Consider a channel with ever growing delay: Suppose that  $d_i$  is a sequence of slowly growing delays. For example,  $d_i = \lceil \log i \rceil$ , and the channel is  $y_i = x_{d_i}$ , where  $x, y$  are binary. The capacity of this channel is  $C = 1$ , whereas  $C_{\text{IFB}} = 0$ . Here, the reason for the gap is the in-ability to utilize the channel structure with a finite block size.

Following these examples the choice of  $C_{\text{IFB}}$  may be justified by two main reasons: one is its operational significance, i.e. that universally attaining  $C_{\text{IFB}}$ , means competing with every static block coding system, and the other is the rejection of eccentric behaviors of the channel, such as the ones mentioned in the examples above.

Note that although  $C_{\text{IFB}} \leq C$ , the universal system presented here may opportunistically achieve rates above  $C$ . This means the communication rate may exceed  $C$  in part of the

time. Consider for example the binary non-ergodic channel that in probability  $p$  has  $\mathbf{y} = \mathbf{x}$ , and in probability  $1 - p$  the output is independent of the input. Then while the capacity of this channel is  $C = 0$  (and  $C_{\text{IFB}} = 0$ ), by adapting the rate, one could attain a rate of 1 in probability  $p$ .

An interesting question is whether for a general vector channel,  $C_{\text{IFB}}$  can be universally attained. Unfortunately the answer is negative, and the reason is that since the input sequences used by the reference encoder and by the universal system are different, infinite memory in the channel may cause the channel to get “stuck” in an unfortunate state. This phenomenon may be nicknamed a “password” channel, since it is similar to a situation where a password is required at the beginning of transmission, otherwise the channel becomes useless. In this case, a reference system knowing the password may succeed and a universal system, having only one attempt to find the password, is bound to fail. In other words, given an encoder, a channel can be structured such that it will identify the specific encoder’s codebook, and fail if any deviation from this codebook is observed. Here is a simple example:

**Example 3.** Consider a family of two binary channels. In the first channel, if  $x_1 = 0$  then the channel will become clean  $i \geq 2$ , i.e.  $\forall i \geq 2 : y_i = x_i$ , but if  $x_1 = 1$ , then it becomes blocked, i.e.  $\forall i \geq 2 : y_i = 0$ . The second channel is the same, except the roles of 0, 1 are reversed. Clearly, for both channels  $C_{\text{IFB}} = 1$ , since the only constraint required to avoid blocking is that the first symbol in each encoded block is constant 0 or 1, and therefore a rate of  $\frac{k-1}{k}$  can be obtained with block size  $k$ . On the other hand, no universal system can guarantee any rate with a vanishing error probability, since any choice of the first symbol will lead to blocking in one of the two channels.

The conclusion from the above is that the concept of iterated finite block capacity is not as strong as the concept of finite state compressibility, which is truly universally attainable. This problem relates to a fundamental difficulty in universal communication compared to universal compression: in universal compression the sequence is given, one can compare different encoders operating on the same sequence, and the major difficulty is dealing with the unknown future of the sequence. In universal communication there is an additional difficulty because the encoder’s actions (the input symbols) affect the channel behavior in an unexpected way.

One may be tempted to think that depriving the IFB class from its block-wise operation and limiting it to i.i.d. distributions would solve the “password” problem. However it is easy to devise a channel that would identify the input distribution of the reference encoder, while blocking the universal system. See Example 5 in Appendix F. These difficulties exemplify the complexity of the universal communication problem.

## V. UNIVERSAL COMMUNICATION OVER THE THE MODULO-ADDITIVE CHANNEL

This section and the next, focus on the modulo-additive channel with an individual noise sequence. It is shown that the IFB capacity of this channel is bounded by  $(1 - \rho(\mathbf{z})) \log |\mathcal{X}|$  and that this rate is universally achievable. Upper and lower

bounds on the convergence rates are given, which show that, unfortunately, the transmission length  $n$  required to obtain universal communication grows exponentially with the block length  $k$  of the competing system.

The modulo-additive channel is a relatively “easy” case because of two main reasons:

- It is memoryless in the input, and thus the “password” issue is avoided.
- There is a single input prior, the uniform i.i.d. distribution, which attains capacity for any noise sequence (since it maximizes the output entropy), therefore no adaptation of the prior is needed.

### A. A bound on the IFB capacity of the modulo-additive channel

In this section the following Theorem is proven:

**Theorem 1.** *The IFB-capacity of the modulo-additive channel  $\mathbf{y} = \mathbf{x} + \mathbf{z}$  where  $\mathbf{x}, \mathbf{y}, \mathbf{z} \in \mathcal{X}^\infty$  are infinite sequences denoting the channel input, output and noise sequence, satisfies*

$$C_{\text{IFB}} \leq (1 - \rho(\mathbf{z})) \cdot \log |\mathcal{X}| \quad (2)$$

where  $\rho(\mathbf{z})$  is the finite state compressibility of  $\mathbf{z}$ .

For the sake of completeness let us shortly repeat the definition of finite state compressibility. A finite state encoder  $F$  with  $s$  states is defined by a next state function  $g : (\{1, \dots, s\}, \mathcal{X}) \rightarrow \{1, \dots, s\}$ , and an output function  $g : (\{1, \dots, s\}, \mathcal{X}) \rightarrow \{\{0, 1\}^k\}_{k=0}^\infty$ , where the output may be a bit sequence of any length, including the empty sequence. The encoder is said to be *information lossless* if for any  $\mathbf{z}_1^n$ , the input  $\mathbf{z}_1^n$  can be uniquely decoded from the output sequence, given the initial and terminal states. Let  $F(s)$  denote the group of all finite state information lossless encoders with at most  $s$  states. Let the length of the output sequence for an input sequence of length  $n$  be denoted  $L(F(\mathbf{z}_1^n))$ , then the compression ratio of  $\mathbf{z}_1^n$  by  $F$  is defined as:

$$\rho_F(\mathbf{z}_1^n) \triangleq \frac{1}{n \log |\mathcal{X}|} L(F(\mathbf{z}_1^n)) \quad (3)$$

The compression ratio of the best information lossless finite state encoder with at most  $s$  states is denoted:

$$\rho_{F(s)}(\mathbf{z}_1^n) \triangleq \min_{F \in F(s)} \rho_F(\mathbf{z}) \quad (4)$$

And finally, the finite state compressibility of the infinite sequence  $\mathbf{z} = \mathbf{z}_1^\infty$  is defined as:

$$\rho(\mathbf{z}) = \lim_{s \rightarrow \infty} \limsup_{n \rightarrow \infty} \rho_{F(s)}(\mathbf{z}_1^n) \quad (5)$$

Note that the order of limits is critical for this definition, since if the number of states is taken to infinity first, any sequence can be compressed to 1 bit (by having the state machine “remember” and identify the particular sequence). The outer limit exists, since  $\rho_{E(s)}$  is decreasing in  $s$  and bounded from below.

*Theorem 1 proof outline:* Define  $\tilde{\mathbf{Z}}_{b,k}$  as the random vector of length  $k$  formed by selecting one vector from the set of  $b$  vectors  $(\mathbf{z}_{(i-1)k+1}^k)_{i=1}^b$ , with uniform probability of  $\frac{1}{b}$  for each.

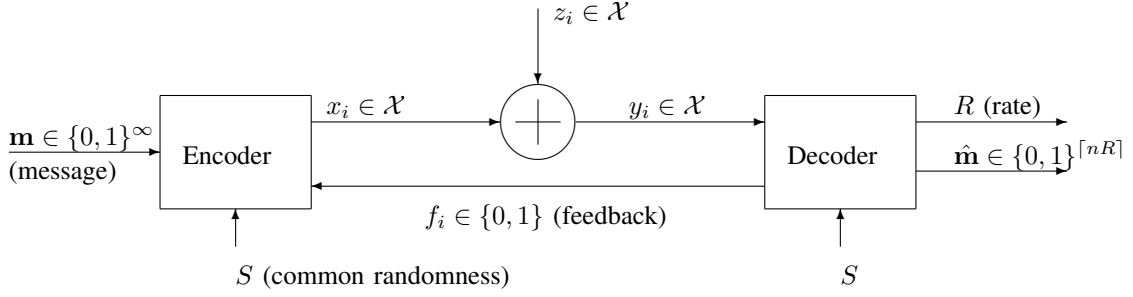

Fig. 4. An adaptive system over the modulo-additive channel with feedback

In other words, the probability distribution of  $\tilde{\mathbf{Z}}_{b,k}$  equals the empirical distribution of the first  $b$  blocks of length  $k$  in  $\mathbf{z}$ . Similarly define the random variables  $\tilde{\mathbf{X}}_{b,k}$  and  $\tilde{\mathbf{Y}}_{b,k}$  derived from the sequences  $\mathbf{x}, \mathbf{y}$ .

Suppose a given  $E, D$  achieve rate  $R$  and average error probability  $\epsilon$  over  $b$  blocks of size  $k$ . This is equivalent to saying they achieve error probability  $\epsilon$  when operating on the stochastic channel  $\tilde{\mathbf{Y}}_{b,k} = \tilde{\mathbf{X}}_{b,k} + \tilde{\mathbf{Z}}_{b,k}$  (Figure 5). Therefore the standard converse of the channel capacity theorem implies that the rate  $R$  can be bounded by  $R \lesssim \log |\mathcal{X}| - \frac{1}{k} H(\tilde{\mathbf{Z}}_{b,k})$ . Then, the limit of  $\frac{1}{k} H(\tilde{\mathbf{Z}}_{b,k})$  is related to the finite state compressibility  $\rho(\mathbf{z})$ . The later relation is a variation of a result by Lempel and Ziv [6, Theorem 3] on the convergence of the sliding-window empirical entropy measured over increasing block lengths to the finite state compressibility (whereas here the block-wise empirical entropy is used instead). The full proof is given in Appendix-A.

Note that the upper bound of Theorem 1 can sometimes be strict, i.e. there are examples of sequences  $\mathbf{z}$  for which  $C_{\text{IFB}} < (1 - \rho(\mathbf{z})) \log |\mathcal{X}|$ , as shown in the following example. We do not have an expression for the IFB capacity.

**Example 4.** Consider for the binary additive channel, the sequence  $\mathbf{z}$  which consists of blocks with ever increasing size. The first half of each block is 0, and the second half block is chosen randomly  $Z_i \sim \text{Ber}(\frac{1}{2})$ . With high probability, the finite state compressibility of the sequence is  $\frac{1}{2}$  (which can be attained, for example, by block-to-variable encoding, using one bit to denote the sequence of zeros). However, the IFB capacity of the channel is 0 in high probability, since for any encoder and decoder with large block size, approximately half of the blocks will be received in error. Therefore there exist sequences for which the inequality is strict.

### B. Universally attaining the IFB capacity over the modulo-additive channel

In this section the results regarding a universal system for the modulo-additive channel with an unknown state sequence are presented. The basis is a result from [12][13], that shows that for a wide range of sequential source encoders, there is a communication scheme that asymptotically attains the rate  $\log |\mathcal{X}| - \frac{1}{n} L(\mathbf{z})$ , where  $L(\mathbf{z})$  is the compression length of the sequence  $\mathbf{z}$  by the source encoder (the number of bits used to encode the sequence). For completeness, the result is stated formally and proven in the appendix (Section C, Theorem 4). Substituting the compression length of the Lempel-Ziv (LZ78)

algorithm, the finite state compressibility is obtained (Theorem 2).

A similar theorem was presented in our previous paper [12]. As shall be seen, both assumptions are satisfied by Lempel-Ziv algorithms (LZ77 [14] and LZ78 [6]). Note the similarity between the rate expression (60) and the capacity of an ergodic stochastic modulo-additive channel (attained with a uniform prior)  $C = \bar{I}(X^\infty; Y^\infty) = \bar{H}(Y^\infty) - \bar{H}(Y^\infty | X^\infty) = \log |\mathcal{X}| - \bar{H}(Z^\infty)$ .  $\frac{1}{n} L(\mathbf{z})$  can be considered a generalized empirical measure of the noise entropy rate. In this sense, Theorem 4 is a generalization of Shayevitz and Feder's result [1]. This result can be considered as a special case of the "individual channels" framework [5][15]. The scheme achieving the claims of Theorem 4 is presented in Section C2. By showing that LZ78 satisfies the conditions, the following can be proven:

**Theorem 2.** *When the system of Theorem 4 is used in conjunction with LZ78 source encoder, over the modulo additive channel, then the following holds: For every noise sequence  $\mathbf{z}$  and every  $\epsilon, \delta > 0$  there is  $n$  large enough so that when the system is operated over  $n$  channel uses, then in probability  $1 - \epsilon$ , the message is correctly decoded and the rate is at least  $(1 - \rho(\mathbf{z})) \log |\mathcal{X}| - \delta$ .*

**Corollary 2.1.** *The system defined above is IFB-universal.*

**Corollary 2.2.** *The system attains the Shannon capacity of every modulo-additive channel with a stationary ergodic noise sequence.<sup>1</sup>*

The proof is given in Appendix B.

Theorems 4,2 are finite horizon, i.e. the system is designed for a given transmission length  $n$ , and because  $n$  needs to grow in order to make the overhead  $\delta$  vanish, the asymptotic universality is obtained by a series of systems rather than a single one (as is standard in information theory). However, it is possible to design horizon-free systems in which the transmission length is not limited and redundancy vanishes with time [13]. The results of this section rely on LZ compression algorithm and stress the relations between channel coding rates and compression ratios, and between IFB capacity and finite state compressibility. This relation is intuitively appealing and the resulting system is relatively simple. On the other hand, the modified universal system presented in the next section yields better bounds on the convergence of the overhead terms, which

<sup>1</sup>Note there is an error in our paper [12] where it was claimed the system only attains the mutual information.

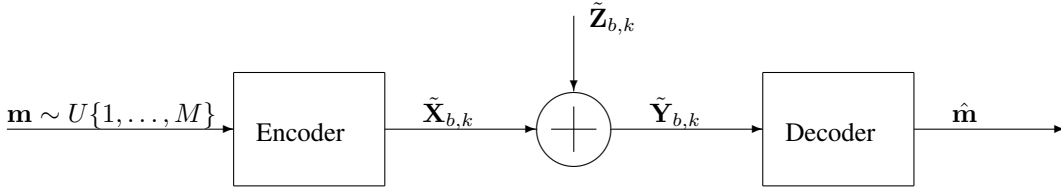

Fig. 5. A probabilistic equivalence to iterative mapping

also hold *uniformly* in  $\mathbf{z}$ .<sup>2</sup>

## VI. THE REDUNDANCY OF THE UNIVERSAL SYSTEM

Let us now consider the redundancy of the universal system and how fast it converges to zero as the block length increases, under the context of the modulo-additive channel. The interesting question is how large the transmission length size  $n$  needs to be, in order to successfully compete with an IFB system of a given block size  $k$ . Unfortunately,  $n$  must grow at least as fast as  $|\mathcal{X}|^k$ , approximately. Thus, even considering reference systems of relatively small block sizes compared to standard block codes (such as  $k = 100$ ), the competition becomes infeasible.

### A. A definition of redundancy

Before giving a definition of the redundancy, some considerations for the definition are provided. The finite state compressibility  $\rho(\mathbf{z})$  used in Theorems 1,2 is irrelevant for the analysis of convergence. This is because  $\rho(\mathbf{z})$  is an asymptotical value, and comparing the performance of a block source encoder or a finite state machine encoder on any finite block of  $n$  symbols, does not indicate anything about the final finite state compressibility. In other words, there is no guarantee on the rate of convergence of the  $\limsup_{n \rightarrow \infty}$  in (5). Consider as example a sequence  $\mathbf{z}$  which is incompressible up to time  $n_1$  and then all zero to infinity, or vice versa (by Kraft inequality, incompressible sequences must exist). Therefore, instead of considering the convergence of the rates obtained by the best IFB system and the universal system to  $(1 - \rho) \log |\mathcal{X}|$ , the comparison is between the rate obtained by the best IFB system of block size  $k$ , with a universal system, at time  $n$ .

While the asymptotic results (Theorem 1, Theorem 2) require the error probability of both systems to tend to zero with  $n$ , at a finite block length a certain non-zero error probability would exist. In the two systems, error probabilities have different meanings: the IFB system's error probability is block-wise and the universal system's error probability is measured on the entire transmission. Therefore, for a fair comparison, and in order to remove the dependence on the error probability from the results, let us consider the following definition of an effective rate, for a system operating over block of size  $k$  with rate  $R$  and error probability  $\epsilon$ :

$$R^* = (1 - \epsilon)R - \frac{1}{k}h_b(\epsilon) \quad (6)$$

<sup>2</sup>Notice that because Theorem 2 essentially indicates convergence to the IFB *capacity*, the convergence cannot hold uniformly in  $\mathbf{z}$ , as the capacity may be obtained by competing systems of unlimited complexity, depending on the noise sequence.

This definition is motivated by Fano's inequality (see (47)). While the first factor is usually termed the good-put (the number of error free bits.), the second factor compensates for the uncertainty in knowing whether there is an error or not. For example, a system delivering  $R = 1$  bit per channel use with error probability  $\epsilon = \frac{1}{2}$  per block of size  $k = 1$  (i.e. transmits no information) would have  $(1 - \epsilon)R = \frac{1}{2}$  but  $R^* = 0$ . Equivalently,  $R^*$  may be interpreted as the minimum value of normalized mutual information between the input message and decoded message, given the parameters  $R, \epsilon$  and  $k$ .

Another issue is how to compare a universal system with transmission length  $n$  and an IFB system whose block length  $k$  does not divide  $n$ . For a worst-case comparison, let us give the IFB system the luxury of using the last block that possibly extends beyond the  $n$ -th symbol (i.e.  $l = \lceil \frac{n}{k} \rceil$  blocks overall), while letting the noise sequence on these symbols  $\mathbf{z}_{n+1}^{kl}$  take the values which are best for the IFB system.

A definition of the minimax redundancy is given below. Let  $E, D$  define an IFB system with block length  $k$  and rate  $R_{\text{IFB}}$  (Definition 2), which is iteratively mapped to the modulo-additive channel with noise sequence  $\mathbf{z}$  of length  $kl$  (where  $l = \lceil \frac{n}{k} \rceil$ ) and yield average error probability  $\epsilon_{\text{IFB}}$  (Definition 3). Similarly, on the same channel over  $n$  symbols, an adaptive system  $U$  with feedback and common randomness (Section IV-D), whose design must not depend on  $\mathbf{z}$ , achieves rate at least  $R_U$  with error probability at most  $\epsilon_U$ . As in Definition 6,  $\epsilon_U$  includes both the probability of error and the probability that the system's rate falls below  $R_U$ . While  $R_U$  is allowed to depend on the noise sequence  $\mathbf{z}$ ,  $\epsilon_U$  is required to be fixed. Let  $R_{\text{IFB}}^* = R_{\text{IFB}}(1 - \epsilon_{\text{IFB}}) - \frac{1}{k}h_b(\epsilon_{\text{IFB}})$  and  $R_U^* = R_U(1 - \epsilon_U) - \frac{1}{n}h_b(\epsilon_U)$ . The rate and error probability for each system, are defined given the noise sequence and the system. The values related to the IFB system,  $R_{\text{IFB}}$ ,  $\epsilon_{\text{IFB}}$  and  $R_{\text{IFB}}^*$  depend implicitly on  $(E, D, \mathbf{z})$ , while the values related to the rate adaptive system  $R_U$ , and  $R_U^*$  depend implicitly on  $U, \mathbf{z}$ .

The minimax redundancy for finite  $n, k$  is defined as follows:

$$\Delta^*(n, k) = \min_U \max_{\mathbf{z}_1^n} \left[ \max_{E, D} (R_{\text{IFB}}^*) - R_U^* \right] \quad (7)$$

I.e. it is the minimal gap  $R_{\text{IFB}}^* - R_U^*$  that can be universally guaranteed by a single system  $U$  over all noise sequences. Note that the definition allows the universal system to depend on  $k$  but this relaxation is not used by the universal system achieving the bounds below.

### B. The minimax redundancy for the modulo-additive channel class

The minimax redundancy of a universal system compared to the IFB system over the modulo-additive channel is bounded as follows:

**Theorem 3.** *The minimax redundancy for the channel  $\mathbf{y} = \mathbf{x} + \mathbf{z}$  satisfies:*

$$\Delta_- \leq \Delta^* \leq \Delta_+ \quad (8)$$

where

$$\Delta_- = \begin{cases} \left\lfloor \log(k\tau) \frac{1}{\log|\mathcal{X}|} \right\rfloor \frac{\log|\mathcal{X}|}{2k} & \tau > \frac{|\mathcal{X}|}{k} \\ \frac{\log|\mathcal{X}|}{2|\mathcal{X}|} \cdot \tau & \tau \leq \frac{|\mathcal{X}|}{k} \end{cases}, \quad (9)$$

and for  $\tau \leq 1$ :

$$\Delta_+ = \frac{\tau}{2} \log\left(\frac{1}{\tau}\right) + \left(\frac{k}{4}\tau^2 + \tau\right) \log e + \delta_n^* + \frac{k}{n} \log(e|\mathcal{X}|). \quad (10)$$

The parameters are defined as follows:

$$\begin{aligned} \tau &= \frac{|\mathcal{X}|^k}{n} \\ \delta_n^* &= 4\sqrt{\frac{\log|\mathcal{X}| \cdot \log(n^2|\mathcal{X}|)}{n}} \end{aligned} \quad (11)$$

Furthermore, the system attaining the upper bound  $\Delta_+$  does not depend on  $k$ .

The theorem is proven in the next section. Note that both bounds require  $\tau$  to be small (and thus  $n$  to be large) in order to achieve a small redundancy. While the lower bound is linear for  $\tau \leq \frac{|\mathcal{X}|}{k}$ , for large values, it increases significantly more slowly (like  $\log \tau$ ). This is because of the in-efficiency of the IFB system used in the lower bound, at high rates. The values of  $\Delta_-$  in the range  $\tau \leq \frac{|\mathcal{X}|}{k}$ , is limited to  $\frac{\log|\mathcal{X}|}{2k}$ , i.e. a rate offset of half a symbol per block. The bound for the range  $\tau > \frac{|\mathcal{X}|}{k}$  is useful, in showing that even if one is satisfied with a redundancy of more than  $\frac{\log|\mathcal{X}|}{2k}$ ,  $\tau$  must be kept small. Fig. 6 illustrates the bounds of Theorem 3 as function of the transmission length  $n$ , for a constant value of  $k$ . The logarithmic and quantized behavior of the lower bound for small values of  $n$  can be observed. Fig. 6 presents the minimum  $n$  required to obtain  $\Delta^*(n, k) \leq \delta \cdot \log|\mathcal{X}|$ , according to the bounds of Theorem 3, as a function of  $k$ . Although the gap between the upper and lower bounds is significant (a little more than an order of magnitude), the trend is similar. These observations are formalized by Corollaries 3.1, 3.2 below, which treat the asymptotical behavior of  $n$ :

**Corollary 3.1.** *For a given  $k$  and  $\delta > 0$ , let  $n^* = n^*(k, \delta)$  be the minimum  $n$  such that  $\Delta^*(n, k) \leq \delta \log|\mathcal{X}|$ . Then*

$$\frac{1}{|\mathcal{X}|} \cdot k|\mathcal{X}|^{(1-2\delta)k} \leq n^* \leq \frac{|\mathcal{X}|^k}{\min[T(k, \delta, |\mathcal{X}|), 1/k]}, \quad (12)$$

where  $g(\tau) = \tau \log\left(\frac{1}{\tau}\right)$  and

$$T(k, \delta, |\mathcal{X}|) = g^{-1}\left(\frac{1}{3}(\delta - 12 \cdot |\mathcal{X}|^{-k/2}) \cdot \log|\mathcal{X}|\right) \quad (13)$$

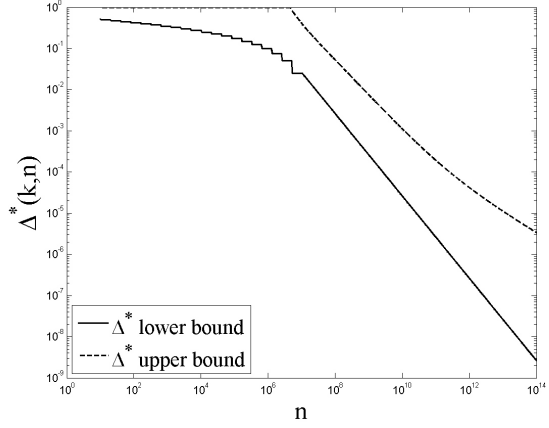

Fig. 6. The upper and lower bound on the redundancy  $\Delta^*(n, k)$  of universal systems given by Theorem 3 for  $k = 20$ ,  $|\mathcal{X}| = 2$ .

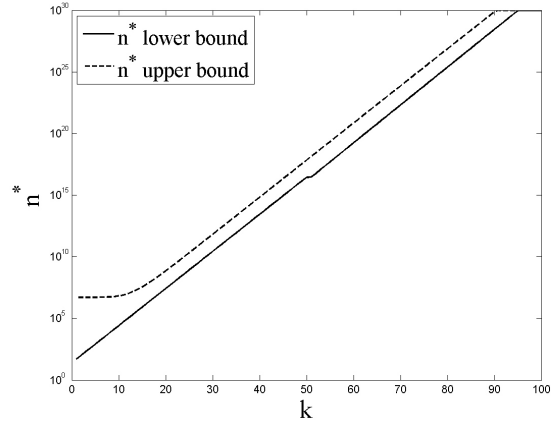

Fig. 7. The minimum transmission length  $n$  required to obtain a minimax redundancy  $\Delta^*(n, k) \leq \delta \cdot \log|\mathcal{X}|$ , according to the bounds of Theorem 3 as function of the IFB block size  $k$ , for  $|\mathcal{X}| = 2$ ,  $\delta = 0.01$ .

### Corollary 3.2.

$$\lim_{\delta \rightarrow 0} \lim_{k \rightarrow \infty} \frac{\log n^*(k, \delta)}{k \log|\mathcal{X}|} = 1 \quad (14)$$

For large  $k$  and fixed  $\delta$ ,  $T(k, \delta, |\mathcal{X}|) \xrightarrow[k \rightarrow \infty]{} g^{-1}\left(\frac{1}{3}\delta \cdot \log|\mathcal{X}|\right) = \text{const}$ , and does not dominate the upper bound (12). For a small value of  $\delta$  both bounds of Corollary 3.1 behave approximately like  $|\mathcal{X}|^k$ . Corollary 3.1 results from a technical simplification of the bounds of Theorem 3 and is proven in Appendix D. Most important is the lower bound on  $n^*$  which indicates the minimum rate at which  $n^*$  must grow. Corollary 3.2 is an immediate consequence of Corollary 3.1, and formalizes the notion that  $n^*$  grows approximately like  $|\mathcal{X}|^k$ .

Note that the system attaining the upper bound of Theorem 3 yields a stronger type of universality than claimed in Theorem 2, because for each value of  $n$ , the overheads are uniformly bounded for any noise sequence  $\mathbf{z}$ , whereas previously, while the overheads are guaranteed to tend to

Fig. 8. The entropy of the noise in the test channel  $H(\mathbf{Z}^n)$  over time, and the lower bound of (??), (??)

zero asymptotically with  $n$ , this convergence is not necessarily uniform with respect to  $\mathbf{z}$ .

It is interesting to note that, while in the previous results presented, the IFB system is used merely as a converse, in the proof for the lower bound  $\Delta_-$  it is required to devise a specific IFB system. Here, the simplicity of the IFB system, which makes the other results intuitive and simple to derive, complicates the proof. The collapsed channel capacity, which upper bounds the IFB system rate, is usually not achievable by a finite block encoder, and a specific channel has to be devised in order for the IFB system to operate provably better than any universal system. It seems that richer classes of reference systems (e.g. systems using feedback as considered in [16]) may result in simpler and tighter lower bounds.

### C. Proof of Theorem 3

1) *Lower bound (reverse part)*: In order to show that the redundancy must be at least  $O\left(\frac{|\mathcal{X}|^k}{n}\right)$  an example random channel is constructed, in the following way. First, the encoder  $E$  is defined. Then, a way to generate noise sequences  $\mathbf{z}$  is defined, such that the noise sequences belong to a sub-set of all possible sequences  $\mathbf{z} \in \mathbb{Z}_d$ , and it is possible to decode the given code with zero error probability (for any noise sequence in the set). The IFB decoder  $D$  is specified only after the noise sequence has been chosen. The sequence  $\mathbf{z}$  is drawn in a randomized way, thus creating a stochastic “test” channel. It is shown that there exists a noise sequence for which the rate of the universal system is bounded by the normalized mutual information over the test channel. Asymptotically, as there are certain constraints on the choice of the noise sequence, this normalized mutual information tends to the rate of the IFB encoder. However, at the beginning of the sequence, the entropy of the sequence is a little higher, and thus the mutual information is a little lower than the long-term average. Thus, the rate of the universal system is bounded by a value lower than the rate of the IFB system.

Let us first describe the IFB encoder and the test channel. The encoder sends  $d$  symbols from the alphabet  $\mathcal{X}$  over  $k$  channel uses, and therefore has a rate

$$R_{\text{IFB}} = \frac{d}{k} \log |\mathcal{X}| \quad (15)$$

The encoding is simple: the first  $k - d$  symbols (prefix) are constant and the rest  $d$  symbols (suffix) contain the message. The decoder would be able to know the value of the noise sequence over the prefix symbols, and knows a list of all possible noise sequences. Assuming that there is no more than one noise sequence with any given prefix, then zero error probability is possible: the decoder finds the noise sequence from the prefix symbols, and cancels it on the suffix to find the message.

The set  $\mathbb{Z}_d$  of allowed noise sequences are simply those sequences for which each prefix  $\mathbf{z}_{k \cdot (i-1)+1}^{k \cdot (i-1)+k-d}$  ( $i = 1, 2, \dots$ ) is unique. The random noise sequence is generated as follows:

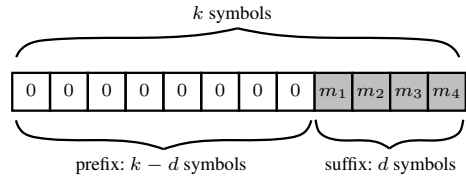

Fig. 9. The reference encoder

at each block of  $k$  symbols, the prefix of  $k - d$  symbols is chosen randomly, uniformly over all possible  $|\mathcal{X}|^{k-d}$  prefixes, and independently of the past noise sequence. Then, if the prefix had appeared before, the suffix equals the suffix of the noise sequence that already appeared. Otherwise, the suffix is chosen randomly, uniformly over all possible  $|\mathcal{X}|^d$  suffixes.<sup>3</sup>

The choice of the first sequence  $\mathbf{z}_1^{[k]}$  is uniform over all possible sequences, and therefore the entropy of the noise sequence in the first block is maximal  $\log(|\mathcal{X}|^k)$ . The choice of the noise sequences narrows with time, and after a long while, all possible prefixes would have been chosen, with one noise sequence per prefix. In this case, the choice of the suffix is determined by the prefix, and the entropy per  $k$ -block is  $\log(|\mathcal{X}|^{k-d})$ . This is the minimum entropy per block attained. The behavior of the entropy  $H(\mathbf{Z}^n)$  in this channel is shown in Fig 8.

Now, because  $\epsilon_{\text{IFB}} = 0$ ,

$$R_{\text{IFB}}^* = (1 - \epsilon_{\text{IFB}})R_{\text{IFB}} - \frac{1}{k}h_b(\epsilon_{\text{IFB}}) = R_{\text{IFB}} = \frac{d}{k} \log |\mathcal{X}| \quad (16)$$

Therefore:

$$\begin{aligned} \Delta^*(n, k) &\stackrel{(7)}{\geq} \min_U \max_{\mathbf{z}_1^n \in \mathbb{Z}_d} \left[ \max_{E, D} (R_{\text{IFB}}^*(E, D)) - R_U^* \right] \\ &\geq R_{\text{IFB}}^* - \min_U \min_{\mathbf{z}_1^n \in \mathbb{Z}_d} [R_U^*] \end{aligned} \quad (17)$$

where  $R_{\text{IFB}}^*$  denotes the value defined in (16) for the specific reference system described.

The universal system guarantees error probability  $\epsilon_U$  for any  $\mathbf{z}$ . By definition, for any  $\mathbf{z}_1^n \in \mathbb{Z}_d$ ,  $R_U \geq R_0 = \min_{\mathbf{z}_1^n \in \mathbb{Z}_d} [R_U]$ . Therefore if  $\mathbf{z}_1^n$  is drawn randomly in  $\mathbb{Z}_d$ , then the universal system yields a rate of at least  $R_0$ , with error probability at most  $\epsilon_U$  over the test channel, and can be converted to a fixed-rate system with feedback with rate  $R_0$  over the same channel. Using Fano's inequality, which holds also in the case of feedback (see (47) in the proof of Theorem 1, and (39)),

$$R_0(1 - \epsilon_U) - \frac{1}{n}h_b(\epsilon_U) \leq \frac{1}{n}I(\mathbf{X}^n; \mathbf{Y}^n) \leq \log |\mathcal{X}| - \frac{1}{n}H(\mathbf{Z}^n), \quad (18)$$

and therefore for any universal system  $U$ :

$$\begin{aligned} \min_{\mathbf{z}_1^n \in \mathbb{Z}_d} [R_U^*] &= (1 - \epsilon_U) \underbrace{\min_{\mathbf{z}_1^n \in \mathbb{Z}_d} [R_U]}_{R_0} - \frac{1}{n}h_b(\epsilon_U) \\ &\leq \log |\mathcal{X}| - \frac{1}{n}H(\mathbf{Z}^n), \end{aligned} \quad (19)$$

<sup>3</sup>An alternative way of generating the noise sequence, which yields the maximum entropy, is by uniform drawing over the set of all possible  $k$ -length sequences that satisfy the unique prefix condition. However this complicates the bound.

which yields the bound:

$$\begin{aligned} \Delta^* &\stackrel{(17),(19)}{\geq} R_{\text{IFB}}^* - \log |\mathcal{X}| + \frac{1}{n} H(\mathbf{Z}^n) \\ &\stackrel{(16)}{=} \frac{1}{n} H(\mathbf{Z}^n) - \frac{k-d}{k} \log |\mathcal{X}| \end{aligned} \quad (20)$$

Asymptotically,  $\frac{1}{n} H(\mathbf{Z}^n) \xrightarrow[n \rightarrow \infty]{\text{Prob.}} \frac{k-d}{k} \log |\mathcal{X}|$ , and thus the bound above tends to 0. The main point of the proof is to bound the convergence rate of  $\frac{1}{n} H(\mathbf{Z}^n)$ .

It may appear surprising, that while it will be shown that the mutual information over the channel is slightly lower than  $R_{\text{IFB}}^*$ , the IFB system transmits rate  $R_{\text{IFB}}^*$  with zero error over this channel. The explanation for this is that the decoder is designed knowing the noise sequence, and therefore its effective rate is not limited by the mutual information.

The rest of this section is dedicated to the rather technical bounding of  $H(\mathbf{Z}^n)$ . The entropy of each prefix, conditioned on the past is  $\log |\mathcal{X}|^{k-d} = (k-d) \log |\mathcal{X}| = k \cdot \bar{H}_1$ , where  $\bar{H}_1$  is the asymptotical entropy rate per symbol. The entropy of the suffix, given the past, changes over time. When choosing the  $i$ -th noise sequence (of length  $k$ ), at most  $i-1$  different prefixes already appeared. Therefore, the probability that the  $i$ -th prefix equals one of the previous ones is at most  $\frac{i-1}{|\mathcal{X}|^{k-d}}$ . Let us define  $i_d^* \triangleq |\mathcal{X}|^{k-d}$  and consider first the case  $i \leq i_d^*$ . In this case, the entropy of the suffix, given all previous symbols, is 0 with probability at most  $\frac{i-1}{|\mathcal{X}|^{k-d}}$ , and  $\log |\mathcal{X}|^d$  with probability at least  $1 - \frac{i-1}{|\mathcal{X}|^{k-d}}$ , and is therefore at least  $\left(1 - \frac{i-1}{|\mathcal{X}|^{k-d}}\right) \cdot d \cdot \log |\mathcal{X}|$ . Formally, define  $P_z^{(i)} \triangleq (\mathbf{Z}_i^{[k]})_1^{k-d}$ ,  $S_z^{(i)} \triangleq (\mathbf{Z}_i^{[k]})_{k-d+1}^k$  as the  $i$ -th prefix and suffix, and  $F_i = \bigcup_{j=1}^{i-1} \{P_z^{(i)} = P_z^{(j)}\}$  as a flag indicating whether  $P_z^{(i)}$  appeared before. Then the entropy of the suffix given the past is:

$$\begin{aligned} H(S_z^{(i)} | \mathbf{Z}_1^{(i-1)k+k-d}) &= H(S_z^{(i)} | \mathbf{Z}_1^{(i-1)k}, P_z^{(i)}) \\ &\stackrel{(a)}{=} H(S_z^{(i)} | \mathbf{Z}_1^{(i-1)k}, P_z^{(i)}, F_i) \\ &= H(S_z^{(i)} | \mathbf{Z}_1^{(i-1)k}, P_z^{(i)}, F_i = 0) \cdot \Pr(F_i = 0) \\ &\quad + H(S_z^{(i)} | \mathbf{Z}_1^{(i-1)k}, P_z^{(i)}, F_i = 1) \cdot \Pr(F_i = 1) \\ &= d \cdot \log |\mathcal{X}| \cdot \Pr(F_i = 0) \\ &\geq d \cdot \log |\mathcal{X}| \cdot \left(1 - \frac{i-1}{|\mathcal{X}|^{k-d}}\right), \end{aligned} \quad (21)$$

where (a) is because  $F_i$  is a function of  $\mathbf{Z}_1^{(i-1)k}$ ,  $P_z^{(i)}$ . Therefore

$$\begin{aligned} H(\mathbf{Z}_i^{[k]} | \mathbf{Z}^{(i-1)k}) &= H(P_z^{(i)} | \mathbf{Z}^{(i-1)k}) + H(S_z^{(i)} | P_z^{(i)}, \mathbf{Z}^{(i-1)k}) \\ &\geq d \cdot \log |\mathcal{X}| \cdot \left(1 - \frac{i-1}{|\mathcal{X}|^{k-d}}\right) + k \cdot \bar{H}_1 \end{aligned} \quad (22)$$

For  $i \geq i_d^*$  simply bound:

$$H(\mathbf{Z}_i^{[k]} | \mathbf{Z}^{(i-1)k}) \geq H(P_z^{(i)} | \mathbf{Z}^{(i-1)k}) = k \cdot \bar{H}_1 \quad (23)$$

Notice that  $\bar{H}_1$  determines the asymptotical entropy rate of the sequence, and matches the bound on the universal system and the rate of the IFB system.

For  $i \leq |\mathcal{X}|^{k-d}$ :

$$\begin{aligned} H(\mathbf{Z}^{ik}) &= \sum_{j=1}^i H(\mathbf{Z}_j^{[k]} | \mathbf{Z}^{(j-1)k}) \\ &\stackrel{(22)}{\geq} \sum_{j=1}^i \left( d \cdot \log |\mathcal{X}| \cdot \left(1 - \frac{j-1}{|\mathcal{X}|^{k-d}}\right) + k \cdot \bar{H}_1 \right) \\ &= d \cdot \log |\mathcal{X}| \cdot \left( i - \frac{(i-1)i}{2|\mathcal{X}|^{k-d}} \right) + ik \cdot \bar{H}_1 \\ &= d \cdot \log |\mathcal{X}| \cdot i \cdot \underbrace{\left(1 - \frac{i-1}{2|\mathcal{X}|^{k-d}}\right)}_{\geq \frac{1}{2}} + ik \cdot \bar{H}_1 \\ &\geq \frac{1}{2} i \cdot d \cdot \log |\mathcal{X}| + ik \cdot \bar{H}_1. \end{aligned} \quad (24)$$

The above implies that the entropy, at times  $n = ik \leq i_d^* k$ , is bounded above the straight line with slope

$$\bar{H}_0 \triangleq \frac{d}{2k} \cdot \log |\mathcal{X}| + \bar{H}_1. \quad (25)$$

See Fig.8. For  $i \geq i_d^*$ ,

$$\begin{aligned} H(\mathbf{Z}^{ik}) &= H(\mathbf{Z}^{i_d^* k}) + \sum_{t=i_d^*+1}^i H(\mathbf{Z}_t^{[k]} | \mathbf{Z}^{(t-1)k}) \\ &\stackrel{(23),(24)}{\geq} k |\mathcal{X}|^{k-d} \bar{H}_0 + k(i - |\mathcal{X}|^{k-d}) \bar{H}_1 \end{aligned} \quad (26)$$

and in general

$$H(\mathbf{Z}^{ik}) \geq ik \cdot \bar{H}_1 + \min(i, |\mathcal{X}|^{k-d}) k (\bar{H}_0 - \bar{H}_1). \quad (27)$$

Consider now  $H(\mathbf{Z}^n)$  for  $n$  that does not, in general, divide by  $k$ . Inside the block of length  $k$ , the per-symbol conditional entropy  $H(\mathbf{Z}_n | \mathbf{Z}^{n-1})$  is  $\log |\mathcal{X}|$  during the prefix, and then increases at a smaller or equal rate during the suffix. Therefore the entropy  $H(\mathbf{Z}^n)$  is concave during the block (Fig.8). Because the entropy at block edges is bounded above straight lines (27), the entropy inside the block is bounded by these lines as well, i.e. (27) can be extended to:

$$H(\mathbf{Z}^n) \geq n \cdot \bar{H}_1 + \min(n, k |\mathcal{X}|^{k-d}) (\bar{H}_0 - \bar{H}_1). \quad (28)$$

Substituting in (20) yields:

$$\begin{aligned} \Delta^* &\geq \frac{1}{n} H(\mathbf{Z}^n) - \frac{k-d}{k} \log |\mathcal{X}| \\ &\stackrel{(28)}{\geq} \bar{H}_1 + \min\left(1, \frac{k |\mathcal{X}|^{k-d}}{n}\right) (\bar{H}_0 - \bar{H}_1) - \bar{H}_1 \\ &\stackrel{(25)}{=} \min\left(1, \frac{k |\mathcal{X}|^{k-d}}{n}\right) \cdot \frac{d}{2k} \cdot \log |\mathcal{X}|. \end{aligned} \quad (29)$$

The bound is true for every  $d \in \{1, \dots, k\}$ . Let us find a value of  $d$  that approximately maximizes the bound for given  $n, k$ . Starting from  $d = k$  and decreasing  $d$ , each decrease of 1 doubles the first term in the RHS of (29), as long as  $\frac{k |\mathcal{X}|^{k-d}}{n} \leq 1$ , and only linearly decreases the second term. Therefore it is beneficial to decrease  $d$  as long as  $\frac{k |\mathcal{X}|^{k-d}}{n} \leq 1$ , and no more than one additional step. For simplicity let us always take the additional step and determine  $d$  as the maximum  $d \in$

$\{1, \dots, k\}$  so that  $\frac{k|\mathcal{X}|^{k-d}}{n} \geq 1$ , or  $d = 1$  if no such  $d$  exists, i.e.

$$d = \max \left( \left\lfloor \log \left( \frac{k|\mathcal{X}|^k}{n} \right) \frac{1}{\log |\mathcal{X}|} \right\rfloor, 1 \right) \quad (30)$$

If  $n \geq k|\mathcal{X}|^{k-1}$ , then  $d = 1$ , and  $\min \left( 1, \frac{k|\mathcal{X}|^{k-d}}{n} \right) = \frac{k|\mathcal{X}|^{k-1}}{n}$ . In this case (29) yields:

$$\Delta^* \geq \frac{1}{2} \frac{|\mathcal{X}|^{k-1}}{n} \cdot \log |\mathcal{X}|. \quad (31)$$

Otherwise,  $\min \left( 1, \frac{k|\mathcal{X}|^{k-d}}{n} \right) = 1$ , and (29) yields:

$$\Delta^* \geq \frac{1}{2} \left[ \log \left( \frac{k|\mathcal{X}|^k}{n} \right) \frac{1}{\log |\mathcal{X}|} \right] \frac{\log |\mathcal{X}|}{k}. \quad (32)$$

Equations (31), (32) are represented in a compact form in (9) above. This proves the lower bound of Theorem 3.  $\square$

2) *Upper bound (direct part)*: The purpose is to show the existence of a universal system that attains a small redundancy with respect to the reference system, which is a result similar to the one of Theorem 2, however with a more careful analysis of the overheads. Following the same logic as the proof of Theorems 1,2, the difference between the good-put of the two systems is bounded by the following relations:

- The relation between  $R_U^*$  and the ideal  $R_{\text{emp}}$  target of the rate adaptive system (i.e. the overhead term of Theorem 4)
- The relation between  $R_{\text{emp}}$  and the collapsed channel capacity (equivalently the collapsed noise entropy  $H(\tilde{\mathbf{Z}}_{l,k})$ )
- The relation between  $R_{\text{IFB}}^*$  and  $H(\tilde{\mathbf{Z}}_{l,k})$  obtained using Fano's inequality (as in the proof of Theorem 1)

Considering the scheme that was described for the achievability result of Theorems 4,2, the largest overhead is due to the second element. This large overhead is in some sense unavoidable, as the converse shows, however it is especially large due to the use of LZ78 algorithm which has a slow  $O(1/\log n)$  convergence rate. Specifically, using [6, Thm 1,2], this term i.e. the bound on  $\frac{1}{n} L_{78}(\mathbf{z}) - \frac{1}{k} H(\tilde{\mathbf{Z}}_{b,k})$  behaves like  $O\left(\frac{\log(|\mathcal{X}|^{2k})}{\log n}\right)$ , i.e. in order for this term to be small, it is not only required that  $n \gg |\mathcal{X}|^{2k}$ , but that this relation holds in the logarithm. For example, to have  $\frac{\log(|\mathcal{X}|^{2k})}{\log n} = \frac{1}{10}$  one needs  $n = |\mathcal{X}|^{20 \cdot k}$ .

To obtain a tighter bound, a more general result from [13] can be applied. [13, Thm.8] shows that for every causal probability distribution  $P(\mathbf{x}|\mathbf{y})$ , i.e. satisfying for all  $i \leq n$ :  $P(\mathbf{x}^i|\mathbf{y}^n) = P(\mathbf{x}^i|\mathbf{y}^i)$ , the rate function  $R_{\text{emp}} = \frac{1}{n} \log \frac{P(\mathbf{x}^n|\mathbf{y}^n)}{Q(\mathbf{x}^n)}$  is adaptively achievable with overhead of  $\delta_n = 3\sqrt{\frac{\log q_{\min}^{-1} \cdot (\log \frac{n}{\epsilon_U} + \log q_{\min}^{-1})}{n}}$ , where  $q_{\min}$  is the minimum non-zero value of  $Q(x_i|\mathbf{x}_{i-1})$ .<sup>4</sup>

Substitute as  $Q$  the uniform distribution  $Q(\mathbf{x}^i) = |\mathcal{X}|^{-i}$  having  $q_{\min}^{-1} = |\mathcal{X}|$ . Take  $P(\mathbf{x}|\mathbf{y}) = P_Z(\mathbf{x}-\mathbf{y})$ , for some probability distribution  $P_Z(\mathbf{z})$ . This choice satisfies the causality condition and yields

$$R_{\text{emp}} = \log |\mathcal{X}| + \frac{1}{n} \log P_Z(\mathbf{x}^n - \mathbf{y}^n), \quad (33)$$

<sup>4</sup>Substituting  $d_{\text{FB}} = 1, D = 0$  in the parameters of the theorem.

with  $\delta_n = 3\sqrt{\frac{\log |\mathcal{X}| \cdot \log \left( \frac{n|\mathcal{X}|}{\epsilon_U} \right)}{n}}$ . While the convergence of  $\delta_n \xrightarrow{n \rightarrow \infty} 0$  requires  $\epsilon_U$  to decay subexponentially with  $n$ , the choice of  $\epsilon_U$  will lead to a reduction of  $\epsilon_U R_{\text{emp}} \leq \epsilon_U \log |\mathcal{X}|$  in rate. For simplicity let us choose  $\epsilon_U = \frac{1}{n}$  as this factor is insignificant. In other words, there exists a system with  $\epsilon_U = \frac{1}{n}$  which with probability  $1 - \epsilon_U$  transmits a rate  $R_{\text{emp}} - \delta_n$  without error over the channel. Therefore

$$\begin{aligned} R_U^* &= R_U(1 - \epsilon_U) - \frac{1}{n} h_b(\epsilon_U) \\ &\geq (R_{\text{emp}} - \delta_n)(1 - \epsilon_U) - \frac{1}{n} h_b(\epsilon_U) \\ &\stackrel{R_{\text{emp}} \leq \log |\mathcal{X}|, (33)}{\geq} R_{\text{emp}} - \delta_n - \epsilon_U \log |\mathcal{X}| - \frac{1}{n} h_b(\epsilon_U) \\ &\geq R_{\text{emp}} - 3\sqrt{\frac{\log |\mathcal{X}| \cdot \log (n^2 |\mathcal{X}|)}{n}} - \frac{1}{n} \log |\mathcal{X}| - \frac{1}{n} \\ &\geq R_{\text{emp}} - 4\underbrace{\sqrt{\frac{\log |\mathcal{X}| \cdot \log (n^2 |\mathcal{X}|)}{n}}}_{\triangleq \delta_n^*}, \end{aligned} \quad (34)$$

where in the last step, for simplification of the bound, it was assumed that  $n \geq \log |\mathcal{X}|$  (otherwise,  $\delta_n$  is large).

If one is interested in competing with an IFB system with block length  $k$ , it would make sense to treat each  $k$  symbols of the noise sequence as a single super-symbol, and take as  $P_Z$  the universal distribution defined by Krichevsky and Trofimov [11] over these super-symbols. This distribution is universal in the sense that up to a small overhead,  $-\frac{1}{n} \log P_Z(\mathbf{z}) \approx \hat{H}(\mathbf{z})$ , i.e. the probability matches the empirical entropy of the sequence, which in the current case is  $H(\tilde{\mathbf{Z}}_{b,k})$ . Furthermore, this holds with a redundancy close to the minimum possible. It is possible to construct a universal distribution  $P_Z$  that compares well with all distributions over the  $n$  symbols which are i.i.d. over  $k$ -length blocks, by a weighted average of Krichevsky-Trofimov distributions.

Let  $\pi_k(\mathbf{z}^k)$  denote a distribution over the  $k$ -letter  $\mathbf{z}^k$ , where  $k$  is not assumed to divide  $n$ . This defines also a distribution on the partial sequence of length  $i < k$  by taking the marginal  $\pi_k(\mathbf{z}^i) = \sum_{\mathbf{z}_{i+1}^k} \pi_k(\mathbf{z}^k)$ . The distribution over  $n$  length vectors, associated with  $\pi_k$  is defined as the i.i.d. extension of  $\pi_k$ , where the marginal distribution is used for the remainder that does not divide by  $k$ . This  $n$ -length distribution will be denoted by the same symbol:

$$\pi_k(\mathbf{z}) \triangleq \prod_{i=1}^{\lfloor n/k \rfloor} \pi_k(\mathbf{z}_{(i-1)k+1}^{(i-1)k+k}) \cdot \pi_k(\mathbf{z}_{\lfloor n/k \rfloor k+1}^n) \quad (35)$$

Then, by weighting Krichevsky-Trofimov distributions it is possible to obtain the following result:

**Lemma 1.** *There exists a distribution  $P_Z(\mathbf{z}_1^n), \mathbf{z} \in \mathcal{X}^n$ , such that for all  $k$  for which  $\tau \triangleq \frac{|\mathcal{X}|^k}{n} \leq 1$ :*

$$\forall \pi_k : \frac{1}{n} \log \pi_k(\mathbf{z}^n) \leq \frac{1}{n} \log P_Z(\mathbf{z}) + \Delta_\pi(k, n), \quad (36)$$

where

$$\Delta_\pi = \frac{\tau}{2} \log \left( \frac{1}{\tau} \right) + \left( \frac{k}{4} \tau^2 + \tau + \frac{k}{n} \right) \log e \quad (37)$$

The detailed derivation and proof appears in Appendix E. The next stage is to relate  $\pi_k(\mathbf{z}^n)$  to  $H(\tilde{\mathbf{Z}}_{l,k})$ . Let  $\mathbf{z}_i^{[k]} \triangleq \mathbf{z}_{(k-1)i+1}^{(k-1)i+k}$  be the  $i$ -th  $k$ -block of  $\mathbf{z}$ . Recall that  $l = \lceil \frac{n}{k} \rceil$  is the number of  $k$ -blocks that cover the  $n$  symbols, and  $\tilde{\mathbf{Z}}_{l,k}$  is a random variable generated by uniform selection out of  $\mathbf{z}_1^{[k]}, \dots, \mathbf{z}_l^{[k]}$ . Let  $P_{\tilde{\mathbf{Z}}_{l,k}}$  be the distribution of  $\tilde{\mathbf{Z}}_{l,k}$  which is the empirical distribution of  $\mathbf{z}_1^{[k]}, \dots, \mathbf{z}_l^{[k]}$ .

$$\begin{aligned} H(\tilde{\mathbf{Z}}_{l,k}) &\triangleq - \sum_{\mathbf{a} \in \mathcal{X}^k} P_{\tilde{\mathbf{Z}}_{l,k}}(\mathbf{a}) \log P_{\tilde{\mathbf{Z}}_{l,k}}(\mathbf{a}) \\ &= -\frac{1}{l} \sum_{i=1}^l \log P_{\tilde{\mathbf{Z}}_{l,k}}(\mathbf{z}_i^{[k]}) \\ &\stackrel{(a)}{=} -\frac{1}{l} \max_{\pi} \log \pi_k(\mathbf{z}_1^{k \cdot l}) \\ &\stackrel{(b)}{\geq} -\frac{1}{l} \max_{\pi} \log \pi_k(\mathbf{z}_1^n) \\ &\stackrel{(36)}{\geq} -\frac{1}{l} (\log P_Z(\mathbf{z}) + n\Delta_{\pi}(k, n)), \end{aligned} \quad (38)$$

where (a) is because the empirical distribution maximizes the joint distribution of the vector; the expression following (a), where the maximization is over all  $k$ -letter distributions  $\pi$ , could be considered an alternative definition of  $H(\tilde{\mathbf{Z}}_{l,k})$ . Transition (b) holds because extending the vector reduces its probability (see also the definition of  $\pi_k(\mathbf{z}^j)$  (35)). Finally, by Fano's inequality (see (47) in the proof of Theorem 1)

$$R_{\text{IFB}}^* = R_{\text{IFB}}(1 - \epsilon_{\text{IFB}}) - \frac{1}{k} h_b(\epsilon_{\text{IFB}}) \leq \log |\mathcal{X}| - \frac{1}{k} H(\tilde{\mathbf{Z}}_{l,k}) \quad (39)$$

Combining the above yields

$$\begin{aligned} R_{\text{IFB}}^* &\stackrel{(39)}{\leq} \log |\mathcal{X}| - \frac{1}{k} H(\tilde{\mathbf{Z}}_{l,k}) \\ &\stackrel{(38)}{\leq} \log |\mathcal{X}| + \frac{1}{kl} (\log P_Z(\mathbf{z}) + n\Delta_{\pi}(k, n)) \\ &\leq \frac{n}{kl} \left( \log |\mathcal{X}| + \frac{1}{n} \log P_Z(\mathbf{z}) \right) \\ &\quad + \frac{kl - n}{kl} \log |\mathcal{X}| + \Delta_{\pi}(k, n) \\ &\stackrel{(33)}{\leq} \frac{n}{kl} R_{\text{emp}} + \frac{k}{n} \log |\mathcal{X}| + \Delta_{\pi}(k, n) \\ &\stackrel{(34)}{\leq} \frac{n}{kl} (R_{\text{U}}^* + \delta_n^*) + \frac{k}{n} \log |\mathcal{X}| + \Delta_{\pi}(k, n) \\ &\leq R_{\text{U}}^* + \delta_n^* + \frac{k}{n} \log |\mathcal{X}| + \Delta_{\pi}(k, n) \end{aligned} \quad (40)$$

Since this holds for any noise sequence and any pair  $E, D$ ,

$$\Delta^*(n, k) \stackrel{(7)}{\leq} \max_{\mathbf{z}, E, D} (R_{\text{IFB}}^* - R_{\text{U}}^*) \stackrel{(39)}{\leq} \Delta_{\pi}(k, n) + \delta_n^* + \frac{k}{n} \log |\mathcal{X}| \quad (41)$$

This proves the upper bound.  $\square$

## VII. DISCUSSION AND EXTENSIONS

The model presented in this paper supplies the first definition of a “universal communication system”, and the results indicate that such universal communication with feedback is possible in the non trivial example of the modulo additive channel with an individual state sequence.

### A. Alternative definitions of universality

The IFB comparison class was chosen as the perhaps simplest and most intuitive comparison class for universal communication. However, it has several drawbacks:

- 1) The reference system is limited in terms of complexity, feedback, etc.
- 2) On the other hand, universality is only achieved at ultra-high values of the transmission length  $n$ . (btw, this is no different from LZ)
- 3) The definition motivates learning  $k$ -periodic structures in the channel, which is counter intuitive. This may be solved e.g. by starting the reference system at an arbitrary time (rather than  $n = 1$ ), or by using structures that are not periodic (e.g. finite state machines [16]).
- 4) While the IFB capacity is limited by the “collapsed channel capacity”, it usually falls short of it. Furthermore, had the channel been a stochastic memoryless one, a rather large block size would be needed for the IFB system in order to yield a small error probability. A possible solution is to define the collapsed channel capacity itself as a target rate, but it is not clear how this should be defined for channels with memory.

1) *Possible enhancements of the IFB class:* In this section several possible extensions in terms of complexity are considered. While there are reasons for such extensions, in our opinion, due to the convergence rate issues (Section VI) the right direction would be to simplify rather than enrich the comparison class.

Since the reference system enjoys the advantage of being designed for the specific noise sequence, this advantage is compensated by imposing some restrictions on the reference system, which are not imposed on the universal system. This is similar to what is done in universal source coding and universal prediction, when the comparison class is too rich. The definition of  $C_{\text{IFB}}$  limits the reference system in several factors, where the universal system is not restricted. Namely its complexity, the use of feedback, common randomness and rate adaptivity. Relaxing any of these factors, may generate a higher value of the target rate (an alternative to  $C_{\text{IFB}}$ ) which is still universally attainable. Some potential variations are given below:

- 1) Randomness: allowing the reference system the use of common randomness.
- 2) Rate adaptivity: allowing rate adaptivity in various levels. Error detection can be considered a very basic level of adaptivity.
- 3) Complexity: definition of the encoder/decoder as finite state machines rather than block encoders/decoders.
- 4) Feedback: allowing the use of (a possibly limited amount of) feedback for the reference system.

The first two extensions (1),(2) are trivial, and are not pursued here in order to simplify the presentation. Misra and Weissman had presented [16] a class of finite state machine encoders and decoders with feedback (termed FS class) that includes all the enhancements above, and had shown that for the modulo-additive channel, the maximum rate achieved by the reference class is at most  $R = (1 - \rho(\mathbf{z})) \log |\mathcal{X}|$ , so the

current result on universality would hold also with respect to this enhanced class. Furthermore, they show that, unlike the IFB class (§IV-E), the FS class achieves the rate  $R$  when the complexity is allowed to grow. Notwithstanding these results, the IFB class is still of interest due to its simplicity, which allows simple analysis and consideration of more complex channel models [10].

Below, these extensions are briefly discussed. Although these extensions have already been made by Misra and Weissman in the context of the modulo-additive channel, it is interesting to consider them also in the context of more general channel models.

**Common randomness:** Allowing the reference system the use of common randomness does not change the results, as long as the common randomness is independent of the noise sequence and/or the block number. This is because the IFB capacity would still be upper bounded by the collapsed channel capacity. This holds also for channels with fading memory [10], where the collapsed channel capacity is used as a bound for the IFB rate.

**Rate adaptivity:** The IFB system may be allowed to choose the transmission rate adaptively at the decoder. A simple form of rate adaptivity is error detection, i.e. the decoder is allowed to choose between rate  $R$  and rate 0. In the later case, decoding errors are ignored. On the other hand, the IFB rate is defined in an effective way, considering how many blocks were actually decoded. Under suitable definitions, the effective rate of the IFB system would still be bounded by the collapsed channel capacity, so the results easily extend. Note that allowing error detection effectively models a block coding system using *automatic repeat request* (ARQ). Note that in any case of rate adaptation, for a fair comparison, the decision on the rate must be made at the decoder based on the received sequence alone.

**Complexity:** In order to achieve competitively universal communication, it is essential that both the reference encoder and the decoder be limited in some way (assuming they are designed knowing the channel). Consider for example, the modulo additive channel. If the encoder is not limited, then it can transmit data at the maximum rate  $\log |\mathcal{X}|$  bits/channel use, by uncoded transmission and subtraction of the noise sequence at the encoder. In this case, the decoder does nothing essentially, so no restrictions on the decoder are not helpful. Conversely, if the decoder is not limited, the encoder can transmit un-coded and the noise sequence can be canceled at the decoder, so the same happens while exchanging the roles. As mentioned, an extension to finite state machines with feedback (FS-class) has already been made [16]. An interesting issue for further study is the universality with respect to the FS-class in general channel models.

**Feedback:** Several types of feedback may be considered:

- 1) Feedback inside the block (where the state is reset from block to block). Because the collapsed channel is a channel with memory, feedback can increase its capacity. Since the increase in capacity is obtained by changing the input distribution (prior) in response to feedback (information on channel state), in order to complete in this case, the universal system would also

need to adapt its input distribution per symbol. Hence, the universal systems presented here and in [10] are not suitable for this setting. However, for the modulo-additive channel, feedback does not increase capacity, because the best input distribution is uniform regardless of any knowledge on channel state (in other words, as easy to see, the bound based on Fano's inequality (47) would hold regardless of feedback), and in this particular case, the results do extend to the case of feedback inside the block (see also [16]).

- 2) Feedback between blocks (encoder of block  $b$  receives a message from decoder of block  $b - 1$ ). This kind of feedback effectively increases the block size of the IFB system, as it allows it to keep track of the block index to some extent by passing it back and forth between the encoder (through the channel) and the decoder (through the feedback link). Of course, this cannot be continued when the number of bits required to represent the block index is larger than  $k \log |\mathcal{X}|$ . In the modulo-additive channel, knowledge of the block index yields the maximum capacity of  $\log |\mathcal{X}|$ . It is interesting to note that, while such feedback seems to considerably strengthen the IFB system, Misra and Weissman [16] showed that the rate of the FS-class is limited in spite of feedback. This is because the restriction is on the number of states rather than on the block length.
- 3) It is possible to allow the reference system the use of asymptotically zero-rate feedback (which does not considerably increase the effective block length and cannot considerably increase the collapsed channel capacity).

2) *An alternative comparison class:* As mentioned a relatively short block size, limits the IFB class from attaining the collapsed channel capacity. This gap is not utilized in the current bounds. The collapsed channel capacity bound would still hold, if the encoder and decoder were allowed to operate over multiple blocks, but treat each block in the same way.

One option to define this class is to limit the encoder to a random encoder over the entire transmission length  $n$ , with an i.i.d. prior of choice (alternatively, i.i.d. in blocks) and limit the decoder to use a memoryless decoding metric (or more generally, alpha decoding, i.e. type-based decoding). Another similar way is to let the encoder and decoder be general but randomly permute the inputs and outputs of the channel. As before, the reference encoder and decoder are limited, but are designed based on full channel knowledge. For the modulo-additive channel, it is easy to see that in both cases, the reference rate would be limited to  $\log |\mathcal{X}| - \hat{H}(\mathbf{z})$ . It is more interesting to discuss these classes in the case of general channels – see [10]. Note that although these reference systems would fail for the password channel defined in Example 3, it is possible to devise an alternative example, showing that universal communication with respect to these classes over general channels is not possible [10].

## B. Other comments

Theorem 4, connecting the transmission rate to the compression rate of the noise sequence is reminiscent of Ahlswede's

channel coding scheme with feedback [17]. This scheme sends information by iteratively compressing the receiver’s uncertainty with regard to the transmitted message. Indeed, Ooi [18] has used this scheme in order to achieve adaptive communication over compound channels, including compound finite state channels. Ooi assumes a compound channel (probabilistic with unknown parameters) and varies the rate by changing the transmission length, while here an individual noise sequence is considered and the rate is varied by changing the number of bits transmitted (using a variable block length is a simpler, particular case, that can be obtained by transmitting a single block, in the scheme presented here). Adapting Ooi’s scheme to the individual noise sequence channel seems complicated while using random coding yields a simple proof for the current result.

The result is also closely related to Ziv’s result [19] regarding universal decoding over compound finite state channels. If Theorem 4 is particularized to the non-adaptive case, then it can be proven and generalized by the tools used there. The decoder in Ziv’s paper uses joint Lempel-Ziv parsing and yields a decoding metric which generalizes in a sense the metric used here, for channels which are not necessarily memoryless (see also Section ??). Theorem 2 and particularly Lemma 1 there, relate the size of the error sets  $M_0, M_u$  (defined there) for the maximum likelihood decoder designed for the finite state channel, and the universal decoder. This relation indicates the rate that can be achieved with a given error probability is asymptotically the same. Furthermore, the only assumption used about the reference (maximum likelihood) decoder is that it uses a finite state metric (see the proof of Lemma 1 there), and thus the IFB decoder falls into this class.

In a previous paper [5] a different framework, termed “individual channels” was considered, in which no relation between the input and output of the channel is assumed a-priori, and the communication rate is given as a function of the input and output sequences. As an example the empirical mutual information  $\hat{I}(\mathbf{x}, \mathbf{y})$  is shown to be achievable. The current results fall under this category - i.e. under the definitions of “individual channels” [5][20] the rate function  $R_{\text{emp}}(\mathbf{x}, \mathbf{y}) = \log |\mathcal{X}| - \frac{1}{n} L(\mathbf{y} - \mathbf{x})$  is asymptotically adaptively achievable (i.e. by an adaptive rate system). Note that one do not need to assume that the channel is truly modulo-additive to show this. It is also possible to show [20] that all achievable rate functions that depend only on the noise sequence  $R_{\text{emp}}(\mathbf{x}, \mathbf{y}) = R(\mathbf{y} - \mathbf{x})$ , are of this form (asymptotically), i.e. given a system attaining the rate  $R_{\text{emp}}(\mathbf{x}, \mathbf{y}) = f(\mathbf{y} - \mathbf{x})$  for each individual sequence with a uniformly distributed channel input, there exists a source encoding scheme with encoding lengths asymptotically approaching  $L(\mathbf{z}) = n \log |\mathcal{X}| - nR(\mathbf{z})$ .

In previous works [1], [4], rates which reflect the average channel behavior such as  $1 - \hat{H}(\mathbf{z})$  were termed “empirical capacity” mainly based on the similarity to the capacity expressions for memoryless channels. The term is not completely justified, since clearly this is not the maximum communication rate. The value  $C_{\text{IFB}}$  seems to be a better candidate to describe the modulo-additive channel’s “empirical capacity”, although as discussed above, other interesting definitions can be sug-

gested. Note that there is no fixed order between  $1 - h_b(\hat{\epsilon})$  and  $C_{\text{IFB}}$ . For example for  $\mathbf{z} = 0, 1, 0, 1, 0, \dots$ , the relation is  $0 = 1 - h_b(\hat{\epsilon}) < C_{\text{IFB}} = 1$ , while in Example 4 the order is inverse  $0 = C_{\text{IFB}} < 1 - h_b(\hat{\epsilon}) = 1 - h_b(\frac{1}{4})$ . On the other hand the relation  $1 - h_b(\hat{\epsilon}) \leq 1 - \rho(\mathbf{z})$  always holds<sup>5</sup>, so the rates achieved by the scheme described here are asymptotically better than the previously achieved rates [1].

Note that the current results assume the noise sequence is fixed and unknown, and cannot be extended to the case where the noise sequence is determined by an adversary (i.e.  $z_i$  is a function of  $x_1^{i-1}$ ), and the reference class is aware of the adversary strategy. To see this, it is very easy to design an adversary that identifies the codebook used by the reference encoder, and locks the channel (by choosing the noise sequence randomly) once a different channel input appears.

Since the current results are focused on the modulo-additive channel, an interesting question is: can the IFB capacity be universally attained over other classes of channels? The results shown here rely on the fact the modulo additive channel is memoryless in the input, and its capacity is obtained by a fixed prior. The former restriction is more crucial and the second can be alleviated [21]. In [10] the current results are extended to the case of channels with memory, under a restriction that this memory fades with time.

## VIII. CONCLUSION

This paper considered target rates for universal systems with feedback and focused on the modulo additive channel. The notion of the *iterated finite block capacity*, denoted  $C_{\text{IFB}}$ , was defined for a vector channel, as the highest rate achievable by encoders and decoders that may be designed for the particular relation that exists between the input and output, yet are constrained to be of finite block length and use the same scheme over each block. The IFB capacity  $C_{\text{IFB}}$  was used as a target communication rate to be achieved without any prior knowledge of the channel, using feedback. It was shown that  $C_{\text{IFB}}$  cannot be achieved universally for completely general input-output relations, however for the modulo-additive channel with an individual noise sequence, it can be achieved universally without knowing the noise sequence. Specifically, it was shown that  $C_{\text{IFB}} \leq (1 - \rho) \log |\mathcal{X}|$ , where  $\rho$  is the finite state compressibility of the noise sequence, and a universal system with feedback attaining a rate of at least  $(1 - \rho) \log |\mathcal{X}|$  was presented. This result is relatively simple due to the properties of the modulo additive channel. In a follow-up paper [10] the result is extended to more general channels.

## APPENDIX

### A. Proof of Theorem 1

Suppose a given  $E, D$  achieve rate  $R$  and average error probability  $\epsilon$  over  $b$  blocks of size  $k$ . Let us adopt the definitions of  $\tilde{\mathbf{X}}_{b,k}$ ,  $\tilde{\mathbf{Z}}_{b,k}$  and  $\tilde{\mathbf{Y}}_{b,k}$  from Section V-A, and likewise define  $\mathbf{m}$  and  $\hat{\mathbf{m}}$  to be random variables generated

<sup>5</sup>This can be shown by block to variable encoding to rate  $h_b(\hat{\epsilon}_i)$ , where  $\hat{\epsilon}_i$  is the empirical probability of 1-s in the block, and the convexity of  $h_b(\cdot)$

by selecting the block index uniformly over  $1, \dots, b$  and taking the respective encoded/decoded (resp.) messages, i.e.  $\mathbf{m} = \mathbf{m}_U$ ,  $\hat{\mathbf{m}} = \hat{\mathbf{m}}_U$ , where  $U \sim U\{1, \dots, b\}$ . Then

$$\begin{aligned} \frac{1}{b} \Pr(\hat{\mathbf{m}}_i \neq \mathbf{m}_i) &= \sum_{i=1}^b \Pr(\hat{\mathbf{m}}_i \neq \mathbf{m}_i) \Pr(U = i) \\ &= \Pr(\hat{\mathbf{m}} \neq \mathbf{m}) \leq \epsilon \end{aligned} \quad (42)$$

The rate  $R$  is now bounded by the entropy of  $\tilde{\mathbf{Z}}_{b,k}$ . By Fano inequality

$$H(\mathbf{m}|\hat{\mathbf{m}}) \leq h_b(\epsilon) + \epsilon \log M \quad (43)$$

Therefore by the information processing inequality

$$\begin{aligned} I(\tilde{\mathbf{X}}_{b,k}; \tilde{\mathbf{Y}}_{b,k}) &\geq I(\mathbf{m}; \hat{\mathbf{m}}) = H(\mathbf{m}) - H(\mathbf{m}|\hat{\mathbf{m}}) \\ &\geq \log M - (h_b(\epsilon) + \epsilon \log M) \end{aligned} \quad (44)$$

On the other hand

$$\begin{aligned} I(\tilde{\mathbf{X}}_{b,k}; \tilde{\mathbf{Y}}_{b,k}) &= H(\tilde{\mathbf{Y}}_{b,k}) - H(\tilde{\mathbf{Y}}_{b,k}|\tilde{\mathbf{X}}_{b,k}) \\ &= H(\tilde{\mathbf{Y}}_{b,k}) - H(\tilde{\mathbf{Z}}_{b,k}) \\ &\leq \log |\mathcal{X}|^k - H(\tilde{\mathbf{Z}}_{b,k}) \end{aligned} \quad (45)$$

Combining the two:

$$(1 - \epsilon) \log M - h_b(\epsilon) \leq I(\tilde{\mathbf{X}}_{b,k}; \tilde{\mathbf{Y}}_{b,k}) \leq k \log |\mathcal{X}| - H(\tilde{\mathbf{Z}}_{b,k}) \quad (46)$$

Therefore

$$R \leq \frac{1}{k} \log M \leq (1 - \epsilon)^{-1} \left[ \log |\mathcal{X}| - \frac{1}{k} H(\tilde{\mathbf{Z}}_{b,k}) + \frac{1}{k} h_b(\epsilon) \right] \quad (47)$$

If  $R$  is an achievable rate then by Definition 4, for any  $\epsilon > 0$  there exist  $k > 0$  such that (47) holds for this  $k$  and  $b$  large enough. Therefore taking  $\liminf_{b \rightarrow \infty}$  on both sides yields:

$$R \leq (1 - \epsilon)^{-1} \left[ \log |\mathcal{X}| - \frac{1}{k} \limsup_{b \rightarrow \infty} H(\tilde{\mathbf{Z}}_{b,k}) + \frac{1}{k} h_b(\epsilon) \right] \quad (48)$$

Next, let us relate  $H(\tilde{\mathbf{Z}}_{b,k})$  to the finite state compressibility. There exists a finite state machine  $\tilde{F}$  with  $s_k = \mathcal{X}^{k-1} \cdot k$  states that compresses the sequence  $\mathbf{z}_1^{km}$  to at most  $b \cdot (H(\tilde{\mathbf{Z}}_{b,k}) + 1)$  bits. This state machine implements a block to variable encoder tuned to the empirical distribution and is structured as follows: its state space includes a counter from 1 to  $k$  which counts the index inside the block, and a memory of  $k - 1$  input characters. When the counter reaches  $k$  the machine outputs an encoded string, and the counter returns to 1. In the other counter states the machine emits the empty string. The encoded string is generated by a simple block to variable encoder optimized to compress the random variable  $Z_{k,b}$  to its minimum average length (e.g. a Huffman encoder, although a simple encoder using lengths  $\lceil \Pr(Z_{k,b})^{-1} \rceil$  is sufficient for this purpose), and therefore its average encoded length for  $\tilde{\mathbf{Z}}_{b,k}$  is at most  $H(\tilde{\mathbf{Z}}_{b,k}) + 1$  [22, Section 5.4]. The encoding

length is therefore:

$$\begin{aligned} &\sum_{i=1}^b L(F(\mathbf{z}_{(i-1)k+1}^{ik})) \\ &= \sum_{\tilde{\mathbf{z}} \in \mathcal{X}^k} b \cdot \hat{P}((\mathbf{z}_{(i-1)k+1}^{ik})_{i=1}^b = \tilde{\mathbf{z}}) \cdot L(F(\tilde{\mathbf{z}})) \\ &= b \cdot \sum_{\tilde{\mathbf{z}} \in \mathcal{X}^k} \Pr(Z_{k,b} = \tilde{\mathbf{z}}) \cdot L(F(\tilde{\mathbf{z}})) \\ &\leq b(H(\tilde{\mathbf{Z}}_{b,k}) + 1) \end{aligned} \quad (49)$$

Therefore for  $n = bk$

$$\begin{aligned} \rho_{F(s_k)}(\mathbf{z}_1^n) &\leq \rho_{\tilde{F}}(\mathbf{z}_1^n) = \frac{1}{n \log |\mathcal{X}|} L(F(\mathbf{z}_1^n)) \\ &\leq \frac{1}{n \log |\mathcal{X}|} b(H(\tilde{\mathbf{Z}}_{b,k}) + 1) = \frac{1}{k \log |\mathcal{X}|} (H(\tilde{\mathbf{Z}}_{b,k}) + 1) \end{aligned} \quad (50)$$

The condition  $n = mk$  may be relaxed and the inequality may be applied to any finite  $n$ , taking  $b = \lfloor \frac{n}{k} \rfloor$  (since if the last block is unfinished it will not contribute to the length, and the normalization by  $n > bk$  will only decrease the LHS).

$$\begin{aligned} \limsup_{n \rightarrow \infty} \rho_{F(s_k)}(\mathbf{z}_1^n) &\leq \limsup_{n \rightarrow \infty} \rho_{\tilde{F}}(\mathbf{z}_1^n) \\ &\leq \limsup_{b \rightarrow \infty} \frac{1}{k \log |\mathcal{X}|} (H(\tilde{\mathbf{Z}}_{b,k}) + 1) \\ &\frac{1}{k \log |\mathcal{X}|} (\limsup_{b \rightarrow \infty} H(\tilde{\mathbf{Z}}_{b,k}) + 1) \end{aligned} \quad (51)$$

$$\begin{aligned} \rho(\mathbf{z}) &= \lim_{s \rightarrow \infty} \limsup_{n \rightarrow \infty} \rho_{F(s)}(\mathbf{z}_1^n) \\ &\leq \limsup_{n \rightarrow \infty} \rho_{F(s_k)}(\mathbf{z}_1^n) \leq \frac{1}{k \log |\mathcal{X}|} (\limsup_{b \rightarrow \infty} H(\tilde{\mathbf{Z}}_{b,k}) + 1) \end{aligned} \quad (52)$$

Combining the above with (48) yields:

$\forall \epsilon : \exists k :$

$$\begin{aligned} R &\leq (1 - \epsilon)^{-1} \left[ \log |\mathcal{X}| - \frac{1}{k} \limsup_{b \rightarrow \infty} H(\tilde{\mathbf{Z}}_{b,k}) + \frac{1}{k} h_b(\epsilon) \right] \\ &\leq (1 - \epsilon)^{-1} \left[ \log |\mathcal{X}| - \log |\mathcal{X}| \rho(\mathbf{z}) + \frac{1}{k} + \frac{1}{k} h_b(\epsilon) \right] \end{aligned} \quad (53)$$

Since the  $k$  obtaining the requirements of Definition 4 may be small, the factor  $\frac{1}{k}$  on the RHS makes the bound loose. To tighten the bound the following argument is used: choose a number  $j > 0$ . If there exist  $E, D$  with block size  $k$  and average error probability  $\epsilon$  over  $b$  large enough which divides by  $j$ , then by treating at each consecutive  $j$  blocks as a new block (and forming the encoder and decoder with block size  $j \cdot k$  by using  $j$  times the original encoder and decoder), then by the union bound if  $\epsilon_i$  denote the error probabilities over the blocks  $i \in \{1, \dots, b\}$ , the error probabilities of the aggregate encoder and decoder will satisfy  $\epsilon'_i \leq \sum_{d=1}^j \epsilon_{(i-1)j+d}$ , and therefore the average error probability will be  $\epsilon' = \frac{1}{b/j} \sum_{i=1}^{b/j} \epsilon'_i \leq \frac{j}{b} \sum_{i=1}^b \epsilon_i = j \cdot \epsilon$ . The

conclusion is that if the requirements of Definition 4 are met for a certain  $\epsilon, k$ , they are also met for  $j \cdot \epsilon, j \cdot k$ . Therefore:

$$\forall j, \epsilon : \exists k : \quad R \leq (1 - j\epsilon)^{-1} \left[ (1 - \rho(\mathbf{z})) \log |\mathcal{X}| + \frac{1}{jk} (1 + h_b(j\epsilon)) \right] \quad (54)$$

Note that Definition 4 requires the rate to be achievable for any  $\epsilon > 0$ , and therefore it is possible to take  $\epsilon \xrightarrow{n \rightarrow \infty} 0$ . By choosing for each  $j, \epsilon = \frac{1}{j^2}$ , denoting  $k_j$  as any  $k$  that satisfies (54) for this  $j$ , and taking the limit  $j \rightarrow \infty$  yields:

$$R \leq \lim_{j \rightarrow \infty} \left\{ \left(1 - \frac{1}{j}\right)^{-1} \left[ (1 - \rho(\mathbf{z})) \log |\mathcal{X}| + \frac{1}{jk_j} (1 + h_b(j^{-1})) \right] \right\} = (1 - \rho(\mathbf{z})) \log |\mathcal{X}| \quad (55)$$

which by Definition 5 proves the theorem.  $\square$

### B. Proof of Theorem 2

To prove Theorem 2, it is first shown that LZ77 [14] and LZ78 [6] fulfil the requirements of Theorem 4. Both algorithms operate by creating a dictionary from previous symbols in the string, compressing a new substring to a tuple containing its location in the dictionary, plus, possibly one additional symbol. In LZ77 the dictionary consists of all substrings that begin in a window of specified length before the first symbol that was not encoded yet. LZ78 parses the string  $\mathbf{z}$  into phrases. Each phrase is a substring which is not a prefix of any previous phrase, but can be generated from concatenating a previous phrase with one additional symbol. The dictionary contains all phrases.

It is easy to make sure that  $L_T$  is monotonous (requirement (2) of Theorem 4). This depends on the way the last phrase in the string is treated (and does not affect the asymptotical performance), since this phrase may be an incomplete substring of a string in the dictionary, and therefore does not naturally terminate and produce a tuple. If, for example, the last phrase is sent without coding, then  $L_T$  will not be monotonous (since adding more symbols to  $\mathbf{z}$  that will terminate the phrase will result in a shorter compression). A simple treatment is to encode the last phrase similarly to other phrases - refer to one of the phrases in the dictionary which is a prefix of the remaining substring, and always give the length of the last substring (or the length of the block) at the end. This way the compression length associated with the last substring does not decrease when the substring is extended.

In order to bound  $L_T(\mathbf{z}) - L_S(\mathbf{z})$  (requirement (1)), it is required to bound the tuple which encodes the last phrase. In LZ78 this tuple carries an index to a previous phrase, plus a new symbol. The number of previous phrases is bounded by  $n$  (a coarse bound, but sufficient for the current purpose), and therefore [22, Lemma 13.5.1] its encoding will be of length  $\log n + \log \log n + 1$ , and the length of the tuple will be  $\log n + \log \log n + c$  (where  $c$  is a constant accounting also for rounding, encoding of the additional symbol, etc). Therefore,

if the encoder ends the block with an indication of its length then  $\Delta_{LZ78}^{\max}(n) = \Delta_{LZ78}(n) \leq 2 \log n + 2 \log \log n + c$ . In LZ77 this tuple carries a pointer to the window and a length (i.e. two numbers bounded to  $\{1, \dots, n\}$ ). Therefore after adding an indication of the length at the termination,  $\Delta_{LZ77}^{\max}(n) = \Delta_{LZ77}(n) \leq 3 \log n + 3 \log \log n + c$ . In both cases  $\Delta_{LZ}^{\max}(n) = O(\log n)$  and the requirement is satisfied. Therefore the compression length  $L_{78}(\mathbf{z})$  may be substituted in Theorem 4.

A result by Lempel and Ziv [6, Theorem 2 (item ii)] shows that for every finite  $s$

$$\rho_{78}(\mathbf{z}_1^n) \triangleq \frac{1}{n \log |\mathcal{X}|} L_{78}(\mathbf{z}_1^n) \leq \rho_{F(s)}(\mathbf{z}_1^n) + \delta_s(n) \quad (56)$$

where  $\delta_s(n) \xrightarrow{n \rightarrow \infty} 0$ . By Theorem 4 for any  $\epsilon > 0$ , the system attains the rate

$$\begin{aligned} R &\geq R_{\text{emp}}(\mathbf{z}) - \delta_n \\ &= \log |\mathcal{X}| \left( 1 - \frac{1}{n \log |\mathcal{X}|} L_{78}(\mathbf{z}_1^n) \right) - \delta_n \\ &= (1 - \rho_{78}(\mathbf{z}_1^n)) \log |\mathcal{X}| - \delta_n \\ &\geq (1 - \rho_{F(s)}(\mathbf{z}_1^n) - \delta_s(n)) \log |\mathcal{X}| - \delta_n. \end{aligned} \quad (57)$$

Fix a value  $\tilde{\delta}$ . Since  $\lim_{n \rightarrow \infty} \delta_n = 0$  it is possible to find  $n_1^*$  large enough so that for any  $n > n_1^*$ ,  $\delta_n \leq \tilde{\delta}$ . For a specific value of  $s$ , because  $\lim_{n \rightarrow \infty} \delta_s(n) = 0$ , it is possible to find  $n_2^*$  large enough so that for any  $n > n_2^*$ ,  $\delta_s(n) \leq \tilde{\delta}$ . Because  $\rho_{F(s)}(\mathbf{z}_1^n)$  (4) is monotonically non-decreasing with  $s$ , then for any  $s$ ,  $\rho(\mathbf{z}) = \lim_{s \rightarrow \infty} \limsup_{n \rightarrow \infty} \rho_{F(s)}(\mathbf{z}_1^n) \geq \limsup_{n \rightarrow \infty} \rho_{F(s)}(\mathbf{z}_1^n)$  (i.e. the limit on  $s$  converges from below). For the same  $s$ , find  $n > n_1^*, n_2^*$  so that  $\rho_{F(s)}(\mathbf{z}_1^n) \leq \limsup_{n \rightarrow \infty} \rho_{F(s)}(\mathbf{z}_1^n) + \tilde{\delta} \leq \rho(\mathbf{z}) + \tilde{\delta}$  (note that due to the lim sup this would not, in general, hold for any larger  $n$ ). Writing (57) for these  $s, n$  yields:

$$\begin{aligned} R &\geq (1 - \rho_{F(s)}(\mathbf{z}_1^n) - \tilde{\delta}) \log |\mathcal{X}| - \tilde{\delta} \\ &\geq (1 - \rho(\mathbf{z}) - 2\tilde{\delta}) \log |\mathcal{X}| - \tilde{\delta} \\ &= (1 - \rho(\mathbf{z})) \log |\mathcal{X}| - (2 \log |\mathcal{X}| + 1) \cdot \tilde{\delta} \end{aligned} \quad (58)$$

Therefore the requirements of Theorem 2 are satisfied by substituting  $\tilde{\delta} = (2 \log |\mathcal{X}| + 1)^{-1} \delta$ .  $\square$

*Proof of Corollary 2.1:* The corollary follows directly from the definition, by application of Theorem 2 and Theorem 1.

*Proof of Corollary 2.2:* Suppose the sequence  $\mathbf{z}$  is drawn by a stationary ergodic source. The mutual information rate is  $\bar{I}(\mathbf{X}; \mathbf{Y}) = \bar{H}(\mathbf{Y}) - \bar{H}(\mathbf{Y}|\mathbf{X}) \leq \log |\mathcal{X}| - \bar{H}(\mathbf{Z})$ , and to obtain an equality, the capacity is obtained by a uniform i.i.d. prior, which maximizes  $\bar{H}(\mathbf{Y})$ . Hence the capacity is  $C = \log |\mathcal{X}| - \bar{H}(\mathbf{Z})$ . It was shown [6, Theorem 4] that the finite state compressibility equals the entropy rate of the source, with probability one. The proposed communication system would asymptotically attain the communication rate  $C$ , without prior knowledge of the noise distribution.

### C. Attaining a rate related to the compression length of the noise

Here the result that the rate  $\log |\mathcal{X}| - \frac{1}{n} L(\mathbf{z})$  can be attained for a wide class of source encoders, is formalized and proved.

1) *Attainability result*: A class of sequential source encoders is first defined, for which Theorem 4 applies. For each sequence  $\mathbf{z}$  define  $L_S(\mathbf{z})$  as the unterminated coding length of the sequence, i.e. the length of the output of the encoder after the input  $\mathbf{z}$  has been fed, but the sequence has not been terminated (i.e. the encoder is expecting additional input), and  $L_T(\mathbf{z}) = L(\mathbf{z})$  as the terminated coding length, i.e. the length of the output when  $\mathbf{z}$  is the complete sequence. The sequence  $\mathbf{z}$  is uniquely decodable from the  $L_T(\mathbf{z})$  bits of the terminated code, but not necessarily from the  $L_S(\mathbf{z})$  bits of the unterminated one. The difference  $L_T(\mathbf{z}) - L_S(\mathbf{z}) \geq 0$  is the information stored in the encoder which has not been output yet. The class is defined by the two requirements:

- 1) The difference between the terminated and unterminated lengths is bounded by an asymptotically negligible value:  $\frac{1}{n}(L_T(\mathbf{z}) - L_S(\mathbf{z})) \leq \frac{1}{n}\Delta_L(n) \xrightarrow{n \rightarrow \infty} 0$   
This can be considered an embodiment of the limitation to “sequential” encoders and precludes encoders that process the entire sequence before producing outputs.
- 2) The encoding length does not decrease when the sequence is extended:  $L_T(z_1^i) \geq L_T(z_1^{i-1})$

**Theorem 4.** *Given a sequential source coding scheme with input symbols from alphabet  $\mathcal{X}$  that satisfies assumptions (1,2), and assigns a codeword length of  $L(\mathbf{z})$  to the sequence  $\mathbf{z} \in \mathcal{X}^n$ , then for any  $\epsilon > 0$  there exists a sequence of adaptive-rate encoders and decoders using common randomness and feedback, for increasing block lengths  $n$  over the channel  $\mathbf{y} = \mathbf{x} + \mathbf{z}$  ( $\mathbf{x}, \mathbf{y}, \mathbf{z} \in \mathcal{X}^n$ ), in which for any individual noise sequence  $\mathbf{z}$  in probability at least  $1 - \epsilon$ , the message is correctly decoded with rate of at least*

$$R \geq R_{\text{emp}}(\mathbf{z}) - \delta_n \quad (59)$$

where

$$R_{\text{emp}}(\mathbf{z}) = \log |\mathcal{X}| - \frac{1}{n}L(\mathbf{z}) \quad (60)$$

$$\delta_n = 3\sqrt{\frac{\log |\mathcal{X}|}{n} \cdot \left[ \log \left( \frac{n \cdot |\mathcal{X}|}{\epsilon} \right) + \Delta_L^{\max}(n) \right]} \xrightarrow{n \rightarrow \infty} 0 \quad (61)$$

and  $\Delta_L^{\max}(n) = \max\{\Delta_L(b)\}_{b=1}^n$ .

2) *The adaptive communication scheme*: To achieve the claims of Theorem 4 a variant of the rate adaptive scheme used in a previous paper [5] is used. This scheme applies repeated “rateless” transmissions: fix a value  $K$  of the number of bits per block. Generate a random codebook of  $\exp(K)$  words chosen independently and distributed uniformly over  $\mathcal{X}^n$  which is known at the encoder and decoder (and comprises the common randomness). In each rateless block  $b = 1, 2, \dots$ , the encoder sends  $K$  bits to the decoder, by sending the respective symbols from codeword indexed by those  $K$  bits. Note that at each block different symbols from the codebook are sent. The block terminates when a termination condition is satisfied at the decoder. Then, the decoder stores the decoded bits and indicates this to the encoder, through the feedback link (a 0-1 feedback is sufficient), and a new block of  $K$

bits begins. The last block is potentially not decoded, if the termination condition is not satisfied at the last symbol.

The decoding and termination rule are specified next. Suppose that the current symbol number is  $i$  and the block number is  $b$ . The last symbol of the previous block (number  $b-1$ ) was sent at symbol  $j$  ( $j = 0$  if  $b$  is the first block). Let  $\hat{\mathbf{x}}_1^j$  denote the transmit sequence that follows from the previous decisions made by the decoder (i.e. is composed of the symbols from the codebook matching the decoded bits at each previously decoded block), and let  $\mathbf{x}_{j+1}^i(m)$  denote the transmitted symbols matching codeword  $m$  ( $m = 1, \dots, \exp(K)$ ).  $\hat{\mathbf{z}}^i(m)$  defined below is the decoder’s hypothesis on the noise sequence  $\mathbf{z}^i$ :

$$\hat{\mathbf{z}}^i(m) = \mathbf{y}^i - (\hat{\mathbf{x}}_1^j, \mathbf{x}_{j+1}^i(m)) \quad (62)$$

Take  $\hat{\mathbf{z}}^j = \mathbf{y}^j - \hat{\mathbf{x}}_1^j$  to be the  $j$  length prefix of  $\hat{\mathbf{z}}^i(m)$  (which is independent of  $m$ ). The decoder calculates the following condition for all  $m = 1, \dots, \exp(K)$ :

$$L_T(\hat{\mathbf{z}}^i(m)) - L_S(\hat{\mathbf{z}}^j) \leq \lfloor (i-j) \cdot \log |\mathcal{X}| - \log \frac{n}{\epsilon} - K \rfloor \quad (63)$$

It announces the end of the block and decodes the bits matching codeword index  $m$  if the termination condition is satisfied with respect to codeword  $m$  (where ties can be broken arbitrarily), and does not terminate the block if the condition fails for all codewords.

Regarding the termination condition (63) note that the LHS starts from a negative value and increases linearly at a rate of  $\log |\mathcal{X}|$  bits per symbol, while the RHS starts from a non-negative value, but for a compressible noise sequence, it is expected to increase at a rate slower than  $\log |\mathcal{X}|$  bits per symbol, therefore if the noise sequence is compressible and the block length  $n$  is large enough, the condition will eventually be met. The scheme suggested above differs from the previously proposed scheme [5] mainly in the fact the termination and decoding condition involves the entire past, rather than just the symbols in the current block.

3) *Proof of Theorem 4*: In order to prove Theorem 4 it is shown that the scheme above achieves an error probability of at most  $\epsilon$ , and if an error does not occur, the number of bits decoded (determined by the number of blocks sent), approaches  $R_{\text{emp}}$  for a suitable choice of  $K$ .

Let us begin by bounding the error probability. First let us calculate the probability that the decoder decides in favor of an incorrect codeword at any given symbol  $i$  (where again  $j$  denotes the end of the previous block), by using a property of the sequential encoder. Consider a sequence  $\mathbf{z}^i$  of length  $i$  which is fed into the sequential source encoder in two stages: first, the first  $j$  symbols are fed (and the encoder has emitted  $L_S(\mathbf{z}^j)$  bits), and then the rest  $i-j$  symbols are fed and the encoding is terminated. Between the  $j$ -th and the  $i$ -th symbol, the encoder has emitted  $L_T(\mathbf{z}^i) - L_S(\mathbf{z}^j)$  additional bits, which can be used to uniquely decode  $\mathbf{z}_{j+1}^i$  when  $\mathbf{z}^j$  is given (since the entire encoded stream can be generated from the first  $L_S(\mathbf{z}^j)$  bits plus these additional bits, and used to decode  $\mathbf{z}^i$ ). Therefore the number of sequences  $\mathbf{z}_{j+1}^i$  for which  $L_T(\mathbf{z}^i) - L_S(\mathbf{z}^j) \leq d$  (where  $d \in \mathbb{N}$ ) is upper bounded by  $\exp(d)$  (since they are in effect encoded by  $d$  bits).

Since the codewords are independent, given the transmitted symbols, the other codewords in the codebook over the period

of the current block are independent sequences uniformly drawn from  $\mathcal{X}^{i-j}$ . Therefore the hypothesized tail of the sequence  $\hat{\mathbf{Z}}_{j+1}^i(m) = \mathbf{Y}_{j+1}^i - \mathbf{X}_{j+1}^i(m)$  for any fixed  $m$  is also uniformly distributed (over the common randomness). Since there are at most  $\exp(d)$  sequences that satisfy  $L_T(\mathbf{z}^i) - L_S(\mathbf{z}^j) \leq d$ , the probability that a particular sequence will satisfy the condition is at most

$$\frac{\exp(d)}{|\mathcal{X}|^{i-j}} \quad (64)$$

and therefore by the union bound, the probability that any of the competing sequences will satisfy the condition is at most

$$\frac{\exp(d) \exp(K)}{|\mathcal{X}|^{i-j}} = \exp(d + K - (i-j) \log |\mathcal{X}|) \quad (65)$$

Substituting the value of  $d$  given by the termination condition  $d = \lfloor (i-j) \cdot \log |\mathcal{X}| - \log \frac{n}{\epsilon} - K \rfloor \leq (i-j) \cdot \log |\mathcal{X}| - \log \frac{n}{\epsilon} - K$ , the error probability per symbol is at most  $\exp(-\log \frac{n}{\epsilon}) = \frac{\epsilon}{n}$ , therefore by the union bound over  $n$  symbols, the probability of any error occurring during the decoding process is at most  $\frac{\epsilon}{n} \cdot n = \epsilon$ .

Next let us analyze the rate achieved by the scheme. The analysis assumes no decoding errors occur. Denote the number of decoded blocks by  $B$  (so potentially there are  $B+1$  blocks, if the last block is not decoded). The proof is based on bounding the value of  $L(\mathbf{z})$  based on the number of blocks.  $\mathbf{z}$  denotes the true noise sequence.

Suppose a block was decoded in symbol  $i$  and the previous block ended at symbol  $j$ . By choosing  $K$  (or  $n$ ) large enough it can be guaranteed that decoding never happens at the first symbol of any block, therefore  $i > j+1$ . By the assumption that no decoding errors occurred the sequence  $\hat{\mathbf{z}}^j$  is identical to  $\mathbf{z}^j$ . In symbol  $i-1$  the decoding condition was not met for any codeword, including the correct one, for which  $\hat{\mathbf{z}}^i(m) = \mathbf{z}^i$ . Therefore it holds, with respect to the true noise sequence, that:

$$L_T(\mathbf{z}^{i-1}) - L_S(\mathbf{z}^j) > (i-1-j) \log |\mathcal{X}| - \log \frac{n}{\epsilon} - K \quad (66)$$

This is an inverted version of condition (63). Note that the floor operator  $\lfloor \cdot \rfloor$  is not needed here since the LHS is an integer.

Using monotonicity of  $L_T$  and the bounded difference  $L_T - L_S$  the following telescopic series is lower bounded:

$$\begin{aligned} L_T(\mathbf{z}^i) - L_T(\mathbf{z}^j) &= L_T(\mathbf{z}^i) - L_S(\mathbf{z}^j) - [L_T(\mathbf{z}^j) - L_S(\mathbf{z}^j)] \\ &\geq L_T(\mathbf{z}^i) - L_S(\mathbf{z}^j) - \Delta_L^{\max}(n) \\ &\geq L_T(\mathbf{z}^{i-1}) - L_S(\mathbf{z}^j) - \Delta_L^{\max}(n) \\ &> (i-1-j) \log |\mathcal{X}| - \log \frac{n}{\epsilon} - K - \Delta_L^{\max}(n) \end{aligned} \quad (67)$$

where  $\Delta_L^{\max}(n) = \max\{\Delta_L(l)\}_{l=1}^n$ . By the same argument, this bound is true also for the undecoded block (with  $i-1 = n$ ). Taking  $j_b$  ( $b = 1, \dots, B$ ) to be the symbol in which block  $b$  ended, and adding  $j_0 = 0$  and  $j_{B+1} = n$  the following bound is obtained by summing (67) over  $B+1$  blocks (including the

undecoded one, which is taken as a block of length 0 if the last block is decoded):

$$\begin{aligned} L_T(\mathbf{z}) &= L_T(\mathbf{z}^{j_{B+1}}) - L_T(\mathbf{z}^{j_0}) \\ &= \sum_{b=1}^{B+1} L_T(\mathbf{z}^{j_b}) - L_T(\mathbf{z}^{j_{b-1}}) \\ &> \sum_{b=1}^{B+1} \left( (j_b - 1 - j_{b-1}) \log |\mathcal{X}| - \log \frac{n}{\epsilon} - K - \Delta_L^{\max}(n) \right) \\ &= n \log |\mathcal{X}| - (B+1) \left( K + \log |\mathcal{X}| + \log \frac{n}{\epsilon} + \Delta_L^{\max}(n) \right) \end{aligned} \quad (68)$$

The actual rate achieved by the scheme is

$$R_{act} = \frac{BK}{n} \quad (69)$$

Extracting  $B$  from (68) and calculating  $R_{act}$  yields:

$$\begin{aligned} R_{act} &= \frac{BK}{n} \\ &\geq \frac{K}{n} \cdot \left( \frac{n \log |\mathcal{X}| - L_T(\mathbf{z})}{K + \log |\mathcal{X}| + \log \frac{n}{\epsilon} + \Delta_L^{\max}(n)} - 1 \right) \\ &= \left( 1 + \frac{\log(|\mathcal{X}|n/\epsilon) + \Delta_L^{\max}(n)}{K} \right)^{-1} R_{emp}(\mathbf{z}) - \frac{K}{n} \\ &\stackrel{(a)}{\geq} \left( 1 - \frac{\log(|\mathcal{X}|n/\epsilon) + \Delta_L^{\max}(n)}{K} \right) R_{emp}(\mathbf{z}) - \frac{K}{n} \\ &\stackrel{(b)}{\geq} R_{emp}(\mathbf{z}) \\ &\quad - \left[ \frac{\log |\mathcal{X}| \cdot (\log(|\mathcal{X}|n/\epsilon) + \Delta_L^{\max}(n))}{K} + \frac{K}{n} \right] \end{aligned} \quad (70)$$

where (a) is because  $\forall x \geq 0 : (1+x)^{-1} \geq 1-x$ , and (b) is because  $R_{emp}(\mathbf{z}) \leq \log |\mathcal{X}|$ . To choose the value of  $K$  that approximately minimizes the overhead term in the lower bound, the following lemma is used:

**Lemma 2.** For  $a > 0, b > 0$  with  $b \leq a$

$$r = \min_{k \in \mathbb{N}} \frac{a}{k} + bk \leq 3\sqrt{ab} \quad (71)$$

*Proof:* It is easy to see by derivation that the minimizer over  $x \in \mathbb{R}$  of  $\frac{a}{x} + bx$  is  $x^* = \sqrt{\frac{a}{b}}$ . Choosing  $k^* = \lceil x^* \rceil$  yields  $k^* \in \mathbb{N}$  and since  $\sqrt{\frac{a}{b}} \leq k^* \leq \sqrt{\frac{a}{b}} + 1$ :

$$\begin{aligned} \frac{a}{k^*} + bk^* &\leq \frac{a}{\sqrt{\frac{a}{b}}} + b \left( \sqrt{\frac{a}{b}} + 1 \right) \\ &= 2\sqrt{ab} + b = 2\sqrt{ab} + \sqrt{b \cdot b} \stackrel{b \leq a}{\leq} 3\sqrt{ab} \end{aligned} \quad (72)$$

Applying the lemma to the choice of  $K$  in (70) yields:

$$\begin{aligned} R_{act} &\geq R_{emp}(\mathbf{z}) \\ &\quad - 3 \underbrace{\sqrt{\frac{\log |\mathcal{X}|}{n}} \cdot \left[ \log(n) + \log \left( \frac{|\mathcal{X}|}{\epsilon} \right) + \Delta_L^{\max}(n) \right]}_{\delta_n} \end{aligned} \quad (73)$$

where by assumption (1),  $\delta_n \xrightarrow{n \rightarrow \infty} 0$ .  $\square$

#### D. Proof of Corollary 3.1

The target is to find the required  $n$  such that  $\Delta^* \leq \delta \log |\mathcal{X}|$ , based on the bounds of Theorem 3. According to the lower bound (9), either  $\tau \leq \frac{|\mathcal{X}|}{k}$ , or  $\left\lfloor \log(k\tau) \frac{1}{\log|\mathcal{X}|} \right\rfloor \frac{\log|\mathcal{X}|}{2k} \leq \delta \log |\mathcal{X}|$ , which combined with  $\lfloor x \rfloor \geq x - 1$  yields, after rearrangement,  $\log(k\tau) \leq (2k\delta + 1) \log |\mathcal{X}|$ , i.e.  $\tau \leq \frac{1}{k} |\mathcal{X}|^{2k\delta+1}$ . This condition on  $\tau$  is always less strict than the former, and because at least one of the conditions should hold, the second always holds. Translating to a condition on  $n$  yields:

$$n = \frac{|\mathcal{X}|^k}{\tau} \geq \frac{1}{|\mathcal{X}|} \cdot k |\mathcal{X}|^{(1-2\delta)k} \quad (74)$$

On the other hand, let us find an  $n$  for which the upper bound is at most  $\delta \log |\mathcal{X}|$ . Define  $g(\tau) = \tau \log\left(\frac{1}{\tau}\right)$ . Assuming  $\tau \leq \frac{1}{2k}$ , then  $g(\tau)$  is monotonically increasing,  $g(\tau) \geq \tau \log(2k)$ , and  $\frac{k}{4}\tau^2 \leq \frac{1}{8}\tau$ . Thus:

$$\begin{aligned} & \tau \log\left(\frac{1}{\tau}\right) + \left(\frac{k}{4}\tau^2 + \tau\right) \log e \\ & \leq \frac{1}{2}g(\tau) + \left(\frac{1}{8} + 1\right) \tau \log e \\ & \leq \frac{1}{2}g(\tau) + \frac{9}{8} \cdot \frac{g(\tau)}{\log(2k)} \log e \\ & = \left(\frac{1}{2} + \frac{9 \log e}{8 \log(2k)}\right) g(\tau) \\ & \leq 3g(\tau). \end{aligned} \quad (75)$$

The same assumption  $\tau \leq \frac{1}{k}$  leads to  $n \geq k|\mathcal{X}|^k$  and thus

$$\frac{k}{n} \leq |\mathcal{X}|^{-k} \quad (76)$$

and

$$\begin{aligned} \delta_n^* & \leq 4 \sqrt{\frac{\log |\mathcal{X}| \cdot \log(k^2 |\mathcal{X}|^{2k+1})}{k |\mathcal{X}|^k}} \\ & \stackrel{(a)}{\leq} 4 \sqrt{\frac{5(\log |\mathcal{X}|)^2}{|\mathcal{X}|^k}} \\ & \leq 10 \log |\mathcal{X}| \cdot |\mathcal{X}|^{-k/2}, \end{aligned} \quad (77)$$

where (a) is because  $\log k \leq (k-1) \log e$ , so  $k^2 \leq \log e^{2(k-1)} \leq |\mathcal{X}|^{3(k-1)}$ . Combining (75), (76), (77) with (10) yields:

$$\begin{aligned} \Delta_+ & \leq 3g(\tau) + |\mathcal{X}|^{-k} \log(e|\mathcal{X}|) + 10 \log |\mathcal{X}| \cdot |\mathcal{X}|^{-k/2} \\ & = 3g(\tau) + \left( |\mathcal{X}|^{-k/2} \left(1 + \frac{\log(e)}{\log |\mathcal{X}|}\right) + 10 \right) \log |\mathcal{X}| \cdot |\mathcal{X}|^{-k/2} \\ & \leq 3g(\tau) + \left(2^{-1/2} \left(1 + \frac{\log(e)}{\log 2}\right) + 10\right) \log |\mathcal{X}| \cdot |\mathcal{X}|^{-k/2} \\ & \leq 3g(\tau) + 12 \log |\mathcal{X}| \cdot |\mathcal{X}|^{-k/2}. \end{aligned} \quad (78)$$

Thus, to guarantee  $\Delta^* \leq \delta \cdot \log |\mathcal{X}|$  is it enough if  $\tau \leq \frac{1}{k}$  and

$$\tau \leq g^{-1}\left(\frac{1}{3}(\delta - 12 \cdot |\mathcal{X}|^{-k/2}) \cdot \log |\mathcal{X}|\right), \quad (79)$$

i.e. it is required that

$$\tau \leq \min\left[g^{-1}\left(\frac{1}{3}(\delta - 12 \cdot |\mathcal{X}|^{-k/2}) \cdot \log |\mathcal{X}|\right), 1/k\right], \quad (80)$$

and equivalently

$$n = \frac{|\mathcal{X}|^k}{\tau} \geq \frac{|\mathcal{X}|^k}{\min\left[g^{-1}\left(\frac{1}{3}(\delta - 12 \cdot |\mathcal{X}|^{-k/2}) \cdot \log |\mathcal{X}|\right), 1/k\right]}. \quad (81)$$

□

#### E. Proof of Lemma 1

For the sake of brevity, as long as a single value of  $k$  is discussed, let  $\mathcal{M} \triangleq \mathcal{X}^k$  denote the super-alphabet of length  $k$  and  $m = |\mathcal{X}|^k$  denote its size. Let  $\pi(\cdot)$  define a distribution over  $\mathcal{M}$ . The Dirichlet $\left(\frac{1}{2}, \dots, \frac{1}{2}\right)$  density over the set of distributions is defined as:

$$w_k(\pi) = \exp(-C_m) \prod_{a \in \mathcal{M}} \pi(a)^{-1/2} \quad (82)$$

where

$$C_m = \log(\Gamma(1/2)^m / \Gamma(m/2)), \quad (83)$$

and for a  $l$ -length vector  $\mathbf{a} \in \mathcal{M}^l$ , let  $\pi(\mathbf{a}) = \prod_{i=1}^l \pi(a_i)$  be the probability given to  $\mathbf{a}$  by the i.i.d. distribution  $\pi(\cdot)$ . Let

$$P_k(\mathbf{a}) = \int_{\Delta_{\mathcal{M}}} \pi(\mathbf{a}) w_k(\pi) d\pi \quad (84)$$

define the weighted average of all probabilities given to  $\mathbf{a}$  by i.i.d. distributions  $\pi(\mathbf{a})$ , where the integral is over the unit simplex  $\Delta_{\mathcal{M}} = \{\pi : \forall a \in \mathcal{M} : \pi(a) \geq 0, \sum_{a \in \mathcal{M}} \pi(a) = 1\}$ . By well known results of Shtarkov, which are detailed in Lemma 1 and Xie and Barron's paper [23], it holds that:

$$\log \frac{\max_{\pi} \pi(\mathbf{a})}{P_k(\mathbf{a})} \leq \frac{m-1}{2} \log \frac{l}{2\pi} + C_m + \left(\frac{m^2}{4l} + \frac{m}{2}\right) \log e \triangleq r_{lk}. \quad (85)$$

Note that the terms that do not scale with  $n$  are usually ignored, because  $m$  is considered fixed, however here they matter, because the question would be how fast  $m$  (equivalently  $k$ ) may grow with  $n$ . Thus for any  $\pi$ :

$$\pi(\mathbf{a}) \leq P_k(\mathbf{a}) \exp(r_{lk}). \quad (86)$$

The same equality would hold when marginalizing the above to any parts of  $\mathbf{a}$  (i.e. summing over the remaining elements of  $\mathbf{a}$ ). Using this observation, let us set  $l = \lceil n/k \rceil$ . Then substituting in (84),  $\mathbf{a} = \mathbf{z}_1^{lk}$  yields

$$P_k(\mathbf{z}_1^{lk}) = \int_{\Delta_{\mathcal{M}}} \pi_k(\mathbf{z}_1^{lk}) w_k(\pi) d\pi, \quad (87)$$

and summing both sides with respect to  $\mathbf{z}_{n+1}^{lk}$ , yields

$$P_k(\mathbf{z}^n) = \int_{\Delta_{\mathcal{M}}} \pi_k(\mathbf{z}^n) w_k(\pi) d\pi. \quad (88)$$

Furthermore, by (86)

$$\forall \pi : \pi_k(\mathbf{z}^n) \leq P_k(\mathbf{z}^n) \cdot \exp(r_{lk}). \quad (89)$$

Let us now bound  $r_{lk}$ . Following Xie and Barron's [23, Remark 7], using  $\Gamma(1/2) = \sqrt{\pi}$  and Stirling's approximation  $\Gamma(m/2) \geq \sqrt{2\pi}(m/2)^{\frac{m-1}{2}} e^{-\frac{m}{2}}$  yields from (83):

$$C_m \leq \frac{m-1}{2} \log \pi - \frac{1}{2} \log 2 - \frac{m-1}{2} \log(m/2) + \frac{m}{2} \log e \quad (90)$$

and from (85):

$$r_{lk} \leq \frac{m-1}{2} \log \left( \frac{l}{m} \right) + \left( \frac{m^2}{4l} + m \right) \log e - \frac{1}{2} \log 2. \quad (91)$$

Note that  $r_{lk}$  is always positive, even when  $l < m$ . When  $l < m$ , the second factor dominates, and the normalized loss  $\frac{r_{lk}}{l}$  does not tend to zero. Therefore it is not useful to consider  $m$  in this region. Assuming  $l \geq m$  (note that since  $m \geq 2$  this also implies  $n \geq k$ ), and substituting  $l = \lceil n/k \rceil \leq n$ ,  $m = |\mathcal{X}|^k$ , yields

$$\begin{aligned} r_{lk} &\leq \frac{|\mathcal{X}|^k - 1}{2} \log \left( \frac{\lceil n/k \rceil}{|\mathcal{X}|^k} \right) + \left( \frac{k|\mathcal{X}|^{2k}}{4n} + |\mathcal{X}|^k \right) \log e \\ &\quad - \frac{1}{2} \log 2 \\ &\leq \frac{|\mathcal{X}|^k}{2} \log \left( \frac{n}{|\mathcal{X}|^k} \right) + \left( \frac{k|\mathcal{X}|^{2k}}{4n} + |\mathcal{X}|^k \right) \log e \end{aligned} \quad (92)$$

Now let

$$P_Z(\mathbf{z}) = \sum_{k=1}^{\infty} 2^{-k} \cdot P_k(\mathbf{z}) \quad (93)$$

then from (89)

$$\forall \pi : \pi_k(\mathbf{z}^n) \leq P_k(\mathbf{z}^n) \cdot \exp(r_{lk}) \leq \frac{P_Z(\mathbf{z})}{2^{-k}} \exp(r_{lk}). \quad (94)$$

and thus

$$\forall \pi : \frac{1}{n} \log \pi_k(\mathbf{z}^n) \leq \frac{1}{n} \log P_Z(\mathbf{z}) + \frac{1}{n} (k \log(2) + r_{lk}). \quad (95)$$

The factor  $\frac{1}{n} (k \log(2) + r_{lk})$  can be coarsely bounded by (92):

$$\begin{aligned} \frac{k \log(2) + r_{lk}}{n} &\leq \frac{|\mathcal{X}|^k}{2n} \log \left( \frac{n}{|\mathcal{X}|^k} \right) \\ &\quad + \left( \frac{k|\mathcal{X}|^{2k}}{4n^2} + \frac{|\mathcal{X}|^k}{n} + \frac{k}{n} \right) \log e \\ &= \frac{\tau}{2} \log \left( \frac{1}{\tau} \right) + \left( \frac{k}{4} \tau^2 + \tau + \frac{k}{n} \right) \log e \\ &\triangleq \Delta_\pi \end{aligned} \quad (96)$$

with  $\tau \triangleq \frac{|\mathcal{X}|^k}{n} \leq 1$ . Combining this bound with (95) yields the result of the Lemma.  $\square$

### F. Password channel for i.i.d. distributions

As noted in Section IV-E even limiting the reference class to i.i.d. input distributions would not solve the ‘‘password’’ problem, and therefore universality is not possible even with respect to such encoders, for general channels. To see this, consider the following example, where the channel identifies the input distribution of the encoder. This is a variation of the ‘‘password channel’’ (Example 3).

**Example 5.** The channel class is a class of binary input-output channels, parameterized by a single a parameter  $p \in [0, 1]$ . For each value of  $p$ , the channel is as follows:

- At each symbol  $k$  in time, if the normalized number of ones at the input  $\mathbf{x}_1^k$  is not within a range of thresholds  $[L_{k,p}, H_{k,p}]$ , then from this time on, the channel ‘‘locks’’

and the output is  $y_k = 0$ . Otherwise, the channel is noise free and the output equals the input  $y_k = x_k$ .

- The threshold sequences  $L_{k,p}, H_{k,p}$  are computed such, that if the input is i.i.d.  $\text{Ber}(p)$ , then with high probability  $1 - \epsilon_0$ , the thresholds will not be crossed during any of the  $n$  symbols (i.e. the channel will not lock). Clearly, as  $k$  increases, the thresholds will converge to  $p$ .

Thus, the channel ‘‘identifies’’ a certain input probability. Notice that all the channels are causal and deterministic, and they allow communication at a rate of approximately  $h_b(p)$ . The ‘‘memoryless’’ reference schemes mentioned above can communicate over this channel using a  $\text{Ber}(p)$  input distribution and approach this rate, with a small error probability. But a universal communication over the class is impossible. Until the channel locks, nothing can be inferred anything about  $p$  from the channel output. Therefore the transmit distribution of the universal scheme until the lock time is independent of  $p$ . On the other hand, any given input sequence, will ‘‘lock’’ some of the channels in the class. Therefore any operation of the universal system is bound to cause some of the channels to lock, and achieve an asymptotically zero rate.

### REFERENCES

- [1] O. Shayevitz and M. Feder, ‘‘Achieving the empirical capacity using feedback: Memoryless additive models,’’ *IEEE Trans. Information Theory*, vol. 55, no. 3, pp. 1269–1295, Mar. 2009.
- [2] S. Verdu and T. Han, ‘‘A general formula for channel capacity,’’ *IEEE Trans. Information Theory*, vol. 40, no. 4, pp. 1147–1157, Jul. 1994.
- [3] A. Lapidoth and P. Narayan, ‘‘Reliable communication under channel uncertainty,’’ *IEEE Trans. Information Theory*, vol. 44, no. 6, pp. 2148–2177, Oct. 1998.
- [4] K. Eswaran, A. Sarwate, A. Sahai, and M. Gastpar, ‘‘Zero-rate feedback can achieve the empirical capacity,’’ *IEEE Trans. Information Theory*, vol. 58, no. 1, Jan. 2010.
- [5] Y. Lomnitz and M. Feder, ‘‘Communication over individual channels,’’ *IEEE Trans. Information Theory*, vol. 57, no. 11, pp. 7333–7358, Nov. 2011.
- [6] J. Ziv and A. Lempel, ‘‘Compression of individual sequences via variable-rate coding,’’ *IEEE Trans. Information Theory*, vol. 24, no. 5, pp. 530–536, Sep. 1978.
- [7] N. Merhav and M. Feder, ‘‘Universal prediction,’’ *IEEE Trans. Information Theory*, vol. 44, no. 6, pp. 2124–2147, Oct. 1998.
- [8] M. Feder and A. Lapidoth, ‘‘Universal decoding for channels with memory,’’ *IEEE Trans. Information Theory*, vol. 44, no. 5, pp. 1726–1745, Sep. 1998.
- [9] N. Merhav and M. Feder, ‘‘Universal schemes for sequential decision from individual data sequences,’’ *IEEE Trans. Information Theory*, vol. 39, no. 4, pp. 1280–1292, Jul. 1993.
- [10] Y. Lomnitz and M. Feder. (2012, Jan.) Universal communication over channels with memory. arXiv:1202.0417 [cs.IT]. [Online]. Available: <http://arxiv.org/abs/1202.0417>
- [11] R. E. Krichevsky and V. K. Trofimov, ‘‘The performance of universal encoding,’’ *IEEE Trans. Information Theory*, vol. 27, no. 2, pp. 199–207, Mar. 1981.
- [12] Y. Lomnitz and M. Feder, ‘‘Communicating over modulo-additive channels with compressible individual noise sequence,’’ in *26-th IEEE Convention of Electrical and Electronics Engineers in Israel (IEEEI)*, Nov. 2010.
- [13] Y. Lomnitz, ‘‘Universal communication over unknown channels with feedback,’’ Ph.D. dissertation, Tel Aviv University, Apr. (first draft expected) 2012, to be available online [http://www.eng.tau.ac.il/~yuval/publications/Yuval\\_PhD\\_report.pdf](http://www.eng.tau.ac.il/~yuval/publications/Yuval_PhD_report.pdf).
- [14] J. Ziv and A. Lempel, ‘‘A universal algorithm for sequential data compression,’’ *IEEE Trans. Information Theory*, vol. 23, p. 337343, Sep. 1977.
- [15] Y. Lomnitz and M. Feder, ‘‘Feedback communication over individual channels,’’ in *IEEE Int. Symp. Information Theory (ISIT)*, Jun. 2009, pp. 1506–1510.

- [16] V. Misra and T. Weissman, "The porosity of additive noise sequences," in *IEEE Int. Symp. Information Theory (ISIT)*, 2012.
- [17] R. Ahlswede, "A constructive proof of the coding theorem for discrete memoryless channels with feedback," in *Proceedings of the Sixth Prague Conference on Information Theory, Statistical Decision Functions, and Random Processes*, 1971, pp. 39–50.
- [18] J. Ooi, "A framework for low-complexity communication over channels with feedback," Ph.D. dissertation, MIT, Cambridge, MA, 1997.
- [19] J. Ziv, "Universal decoding for finite-state channels," *IEEE Trans. Information Theory*, vol. 31, no. 4, pp. 453–460, Jul. 1985.
- [20] Y. Lomnitz and M. Feder. (2012, Mar.) Communication over individual channels - a general framework. arXiv:1203.1406 [cs.IT]. [Online]. Available: <http://arxiv.org/abs/1203.1406>
- [21] ——. (2011, Sep.) Universal communication over arbitrarily varying channels. arXiv:1102.0710 [cs.IT]. [Online]. Available: <http://arxiv.org/abs/1102.0710>
- [22] T. M. Cover and J. A. Thomas, *Elements of Information Theory*. John Wiley & sons, 1991.
- [23] Q. Xie and A. Barron, "Asymptotic minimax regret for data compression, gambling, and prediction," *IEEE Trans. Information Theory*, vol. 46, no. 2, pp. 431–445, Mar. 2000.