

Maintaining Virtual Areas on FPGAs using Strip Packing with Delays

Josef Angermeier^{#1}, Sándor P. Fekete*, Tom Kamphans*², Nils Schweer*, Jürgen Teich[#]

[#] Department of Computer Science 12, University of Erlangen-Nuremberg
Erlangen, Germany
{angermeier, teich}@cs.fau.de

* Department of Computer Science, Braunschweig University of Technology
Braunschweig, Germany
{s.fekete, n.schweer}@tu-bs.de, tom@kamphans.de

Abstract—The computing resources available on dynamically partially reconfigurable devices increase every year enormously. In the near future, we expect that many applications run on a single reconfigurable device. In this paper, we present a concept for multitasking on dynamically partially reconfigurable systems called *virtual area management*. We explain its advantages, show its challenges, and discuss possible solutions. Furthermore, we investigate one problem in more detail: Packing modules with time-varying resource requests. This problem from the reconfigurable computing field results in a completely new optimization problem not tackled before. ILP-based and heuristic approaches are compared in an experimental study and the drawbacks and benefits discussed.

I. INTRODUCTION

Reconfigurable devices offer more and more space and functionality over time and will probably continue to do so in the future. Yet, huge hardware applications can already be instantiated on the reconfigurable chips, or even arrays of processors. Furthermore, nowadays reconfigurable chips are mostly used to instantiate a single application with multiple modules, which might not all be necessary at each instant in time. But as reconfigurable devices evolve further, the offered resources will be large enough to also run completely different applications simultaneously. This development also took place in the software world: In the beginning of the nineties, most personal computers used operating systems such as MS-DOS, which allowed just one single software application to be executed, alone with some drivers. Since then, the increased computing resources have allowed us to run multiple applications simultaneously.

Similar to the software world, multitasking will lead reconfigurable devices to higher efficiency, but will also raise several challenges that must be solved. For example, in order to provide reliability and security, we must make sure that no application can violate the execution of another one. In software this is solved by running each application in its own virtual address space. Each application knows only the virtual addresses of its own resources and parts of the operating system. The virtual addresses are translated at runtime into

physical addresses in the memory. Thus, pages of different applications may lie physically next to each other, but only the approved application may access them. Furthermore, the concept of the virtual address space also facilitated writing software, as each application did not need to bother about the positions of other applications but can assume to be the only user of the processor and the memory.

In order to work out concepts for allowing multitasking on reconfigurable devices, we oriented ourselves on concepts of the software world such as virtual address space. But, as there are some major differences between hardware and software, one cannot just put one concept unchanged from software to reconfigurable devices. One important difference is that on reconfigurable devices, different modules may be executed in parallel while software usually works more sequentially.

The basic idea of our concept which we called "Virtual Area Management" is to partition the available FPGA area into different regions. Each hardware application obtains one contiguous region, which may grow or shrink depending on the applications resource needs. Each running hardware application can reconfigure hardware modules in its region and free or try to allocate more area. In this process, each application does not know the physical position of its modules, but just the relative positions. Thus, it cannot reconfigure any region that belongs to a different application and is concerned only with its own resources. Intermodule communication takes place only in the region of one application. Thus, the modules that must communicate with each other are automatically grouped by position to each other.

Communication between the partial modules and with the input and output periphery is an important point. We assume that the application modules are provided with some means to communicate with each other and to the FPGA's I/O-ports independently from their position (e.g., as described in [1]). There are several possible ways to achieve this goal. We solved the communication problems by using our self-developed platform called ESM (see [2],[3]). It offers—amongst others—a so called crossbar device, which dynamically routes the input and output signals to the position of the corresponding module. Moreover, the modules can communicate to each other using the crossbar. Thus, we can assume that the modules can be placed independent from the positions of the I/O periphery and other the positions of other modules.

¹Supported by DFG grant TE 163/14-2, 14-3, project "ReCoNodes", as part of the Priority Programme 1148, "Reconfigurable Computing".

²Supported by DFG grant FE 407/8-2, 8-3, project "ReCoNodes", as part of the Priority Programme 1148, "Reconfigurable Computing".

A. Related Work

1) *Reconfigurable Computing*: Brebner [4], [5] addressed the problems involved in presenting to a software-oriented user a larger virtual hardware resource that is implemented using smaller physical FPGA hardware. Their approach is based on using swappable units, and a prototype operating system is described that demonstrates operational steps. In contrast to that work, this paper does not address the problem of overcoming the physical constraints given by a small FPGA, but tackles the problem, how to run multiple applications on a single reconfigurable resource.

Bazargan et al. [6] present fast online placement methods for dynamically reconfigurable systems, as well as offline 3D placement algorithms. Hereby, partial modules are to be placed completely independent of each other, and the inter-module communication problem is not addressed. Steiger et al. [7] and Diessel et al. [8] further improve scheduling methods for partially reconfigurable systems. Our approach is based on the differentiation between applications and modules. Modules belonging to the same application are placed nearby, such that inter-module communication can be as efficient as possible. Different scheduling subproblems have been addressed meanwhile; for example, scheduling with respect to the reconfiguration overhead [9]. Banerjee et al. [10] take into account hardware-software partitioning decisions for a fast execution of an application. But in contrast to our paper, all these approaches still focus on executing a single application.

Some operating systems for reconfigurable embedded platforms were developed [11], [12], [13]. Such an operating system provides a minimal programming model and a runtime system. The runtime system performs online task and resource management. Scheduling problems are formulated for the 1D and 2D resource models and developed heuristics are compared to each other. Resources of the operating system and the user applications are clearly differentiated, but that is not the case for the resource access of multiple applications running on the FPGA. Our paper suggests a compromise for the inter-module communication problem: Modules belonging to the same application should be placed nearby to each other, such that they can exchange data efficiently. Modules belonging to different applications are not necessarily placed nearby. Additionally, in contrast to our application model, no application can shrink and grow during runtime. The focus in former works was put more on hardware and software abstraction, here it is on securely running multiple, dynamic hardware applications.

Many recent works focused on achieving optimal performance to put multiple tasks onto one FPGA within this context. Cordone et al. [14] and Redaelli et al. [15] specified a new model for partitioning and scheduling on partially dynamically reconfigurable hardware. The different applications are represented by a task graph and the aim is to obtain a total execution time near optimality by taking reconfiguration and communication times into account. However, this approach does not allow dynamic behavior, such that according to the current state of the resources, the tasks can select on their own which module implementation to reconfigure next and at

which nearby position to place it.

The approach by Cardoso [16] also considers the topic of resource virtualization on FPGA devices, achievable due to dynamic reconfiguration capabilities. Hereby, a new temporal partitioning algorithm is proposed. The model by Banerjee et al. [17] furthermore also supports HW/SW partitioning of the tasks. However, both approaches are also based on the assumption that the running times of each task can be estimated roughly, and that the worst-case execution time does not differ too much from the average case. In contrast to that, our approach may also be engaged for the online case, where this must not be the case.

2) *Packing*: It turns out that placing hardware modules with growing and shrinking area resources amounts to strip packing. The classical strip packing problem was first considered by Baker et al. [18]. In this problem a set of rectangles must be packed into a strip of semi-infinite height and width 1 such that the total height of the packing is minimized. They showed that in the online case the bottom left heuristic does not guarantee a constant competitive ratio for packing a sequence of rectangles. For the offline case they proved an upper bound of 3 for a sequence of rectangles and of 2 on the competitive ratio for a sequence of squares; both analyses require the elements to be sorted. Later Kenyon and Rémila designed a fully polynomial time approximation scheme for the offline setting [19]. For the online case Baker and Schwarz [20] introduced the so-called shelf algorithms with an competitive ratio that can be made arbitrarily close to 1.7. Csirik and Woeginger [21] showed a lower bound of 1.69103 for any shelf algorithm and introduced an algorithm whose asymptotic worst-case ratio comes arbitrarily close to this value.

In the classical game of Tetris the aim is to find online placements for a sequence of objects—not all having rectangular shape—such that space is utilized as well as possible. In this process, no item can ever move upward, no collisions between objects must occur, an item will come to a stop if and only if it is supported from below, and each placement must be placed before the next item arrives. Obviously, there is a slight difference in the objective function, as Tetris aims at filling rows. In actual optimization scenarios, this is less interesting, as it is not critical whether a row is used to precisely 100%. Even when disregarding the difficulty of ever-increasing speed, Tetris is notoriously difficult: As shown by Breukelaar et al. [22], Tetris is PSPACE-hard, even for the original, limited set of different objects. Azar and Epstein [23] considered Tetris-like online packing of rectangles into a strip where each item must be moved on a collision-free path to its final position which does not have to be supported from below. Just like in Tetris, they considered the situation with or without rotation of objects. For the case without rotation, they showed that no constant competitive ratio is possible, unless there is a fixed-size lower bound of ε on the side length of the objects, in which case there is an upper bound of $O(\log \frac{1}{\varepsilon})$. For the case in which rotation is possible, they showed a 4-competitive strategy, based on shelf-packing methods, with all rectangles being rotated to be placed on their narrow sides. Coffmann, Downey, and Winkler [24] considered probabilistic aspects of online rectangle packing with Tetris constraint,

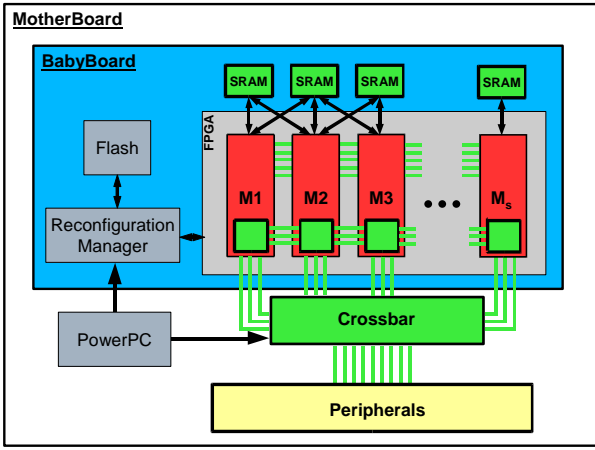

Fig. 1. Architecture overview our ESM platform (see [2],[3] for more details).

without allowing rotations. If rectangle side lengths are chosen uniformly at random from the interval $[0, 1]$, they showed that there is a lower bound of $(0.31382733\dots)n$ on the expected height of the strip. Using another kind of level-type strategy, which arises from the bin-packing–inspired *Next Fit Level*, they established an upper bound of $(0.36976421\dots)n$ on the expected height. Fekete et al. [25] considered an Tetris-like online packing with gravity; that is, every item must be supported from below in its final position. For squares they gave an algorithm with competitive ratio 2.6154.

Note that none of the previous works allows stretching the objects in any direction.

II. VIRTUAL AREA MANAGEMENT

A. Main Idea

Our concept is aimed at partially dynamically reconfigurable architectures, where modules loaded onto the reconfigurable device may be exchanged at runtime. A typical structure of such a device is given in Fig. 1. Yet devices are available which allow the reconfiguration of columns only, while newer platforms also allow reconfiguration of certain contiguous cells. The former is called 1D reconfiguration, the latter 2D reconfiguration. Our concepts are applicable to both architectures. Furthermore, the platform should consist of one control CPU, which may be placed externally or be included into the reconfigurable device.

To run different applications on the reconfigurable device, we propose to partition the available reconfigurable area into so called *virtual areas* (VAs). For performance reasons, the different VAs should consist of contiguous reconfigurable area units. As the required amount of resources of an application changes over time, the size of the virtual area may change dynamically over the running time of its application. The mapping of virtual area to physical reconfigurable area is done by the control processor. Each hardware application being executed on the reconfigurable device has its own software control thread running on this CPU, see Fig. 2. These threads request the initially required area and transmit changes in the requirements. An operating system service on the software side takes the requests and is in charge of the management of

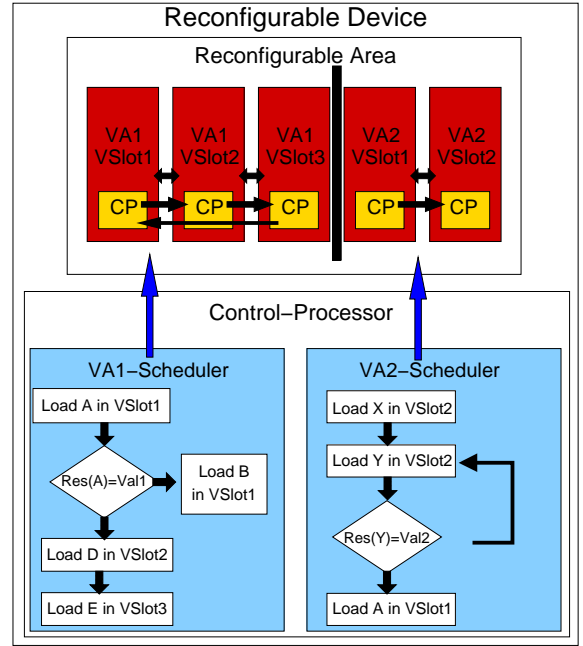

Fig. 2. Two different hardware applications running on a 1D partially dynamically reconfigurable device: The first three slots form the first virtual area (VA1), the remaining the second virtual area (VA2). Modules in one VA can communicate with each other, e.g. by using their communication point (CP) belonging to reconfigurable bus. Neither the first nor the second application knows the exact position of its VA on the reconfigurable device; only the size of the available area and the relative positions of the reconfigurable modules loaded in its virtual area are known.

the virtual areas. This secure operating system unit maps the virtual area units to the corresponding physical dynamically reconfigurable area units. The virtual area management unit can be compared to the memory management unit (MMU) in the software world: both handle the translation of virtual to physical memory positions. Furthermore, the corresponding application software threads do not know the actual physical positions of the reconfigured modules, only the relative positions of each reconfigurable module to each other. Each application simply requests to load a specified module to a virtual position in the assigned virtual area. See the example in Fig. 2: The second application with its virtual area VA2 issues a request to load a specified bit-file called “X” to the virtual address (here called: *VSlot* ‘2’). It does not know that this virtual address corresponds physically to the last reconfigurable unit on the reconfigurable device. It knows only that the module loaded there is on the right side of a module loaded to the virtual address (*VSlot* ‘1’). As each application is allowed to specify only a virtual address corresponding to its virtual area in which to place the module, it cannot place a module into an area belonging to a different application.

The concept is transparent to the applied intermodule communication in each virtual area: Each application can choose its preferred communication method (e.g., bus system, neighbor to neighbor communication over bus macros). When only contiguous virtual areas are used, the communicating modules are grouped together automatically and communication overhead is minimized. Furthermore, communication between different applications or heterogeneities of the reconfigurable

area is supported easily by extending the operating system.

Yet there are many other approaches to schedule tasks of different applications, but in contrast to them our approach of virtual areas combines a localization strategy, putting tasks which belong to one application together, and highly dynamic applications, which can individually take different module selection and placement decision based on the current context.

B. Advantages

The idea of virtual area management offers the following advantages when running multiple applications on a single dynamically partially reconfigurable device.

- *Resource accounting*: The concept can be easily used to prevent applications from using too many resources at runtime. One might want to restrict the resources granted to an application for each execution or just in a certain context in order. The goal is, for example, to reduce the power consumption or to accelerate more important applications in a system where certain applications have lower priorities than others. The concept of virtual area management provides a limitation mechanism by granting just a certain amount of, for example, reconfigurable area to an application.
- *Resource protection*: Each application controls only the reconfiguration within its virtual area, as it can only specify those virtual positions that are valid in its own VA. The virtual area management unit checks for each request if the virtual address is valid and translates it into a physical position on the reconfigurable device. This way, no application can load any module to the area of another application and the applications are protected. Thus, an error in one application cannot harm the execution of all other applications and lead to a complete system breakdown.
- *Support for differing scheduling and placement procedures*: Different applications require different scheduling and placement methods to increase performance. Instead of designing complex scheduling algorithms that try to meet all the requirements (e.g., periodic or aperiodic, with or without deadlines) by introducing various priority classes, each application gets its own virtual area and specifies the best scheduling strategy. This may include a simpler and faster implementation of new hardware applications within an existing system.
- *Area position transparency and programming dynamic applications*: The absolute positions' independence of the executed modules, in the following called *area position transparency*, offers a new programming model. It allows to write dynamic applications, which subject to the current resource context decide on their own how to proceed. Depending on the assigned area, an application can either use an implementation that offers more performance but needs more area, or another one that takes longer but uses less area. Another new possibility is that the application can decide how to increase and shrink depending on the current area usage context. An application can ask the virtual area management unit, if it can grow to the

left or right, or at the bottom, and, depending where some unused area is available, it can decide to put a partial module there and instantiate some appropriate communication module to transfer data there and back. Thus, at each run, an application can operate differently in its amount of resource usage. Before, trade-off decisions where also possible for a single application, but the new idea is to let each application decide in its own control program its next steps depending on the behavior of the other applications.

C. Challenges

First, there are some technical problems to be solved. For area position transparency, the placement of a module should not be limited to one single position. Furthermore, there might be heterogeneities on the reconfigurable device which require different implementation for different positions. A possible solution to this problem is to generate implementations for the module for each possible position where the corresponding virtual area can be placed. The corresponding module implementation bit-files can be compressed to save some space. Another option is to apply a single generated module bit-file and relocate this file; that is, adapt it to the corresponding position. We solved this technical issue in the following way: Our experimental board is equipped with a reconfiguration manager device that manipulates the corresponding bit-files before the reconfiguration of the corresponding device.

A further technical challenge lies in the communication of the partial modules to the external periphery (e.g., video, audio) over the input/output pins at the border of the FPGA. Our experimental board has a crossbar device that routes I/O signals dynamically from the periphery to the current position of the partial module.

A larger challenge is to fulfill the changing resource requirements of the different applications. Every application has a different resource usage profile which depends on the inputs specified. An application called with a larger problem instance to solve needs also more resources. Additionally, the resource usage profile also depends on the execution context. The application may behave differently depending on how many area resources are available at each position. Furthermore, the resource requirement depending on the inputs of an application may or may not be known in advance (or at least can be estimated, e.g., in a numerical application based on the required precision of the solutions). The former is called the offline case, the latter the online case.

In the online case, a deadlock is possible when two applications currently running on the reconfigurable device can only proceed in their task when an resource increase is granted, see Fig. 3. The blocks represent the occupied area of one application at different points in time. The leftmost application needs two more area units, as does the application second from the left. Furthermore, no application can give up its accumulated resources, as saving and restoring states is widely considered too expensive on FPGAs. Such a deadlock must be prevented. A commonly used solution is to allow hardware task preemption: If not enough resources are available to

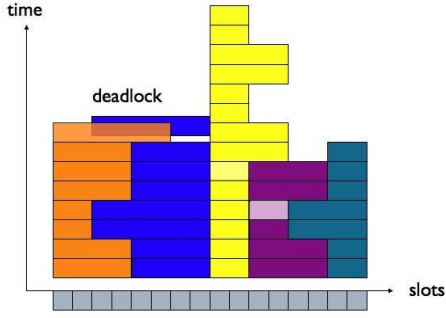

Fig. 3. Both the first and the second application (from the left), request more area resources in order to proceed. A deadlock occurs, because no more resources are available to meet any request.

meet increased resource demands, the state of one application is stored in external memory. At a later point in time, the application is loaded again on the reconfigurable device and the state be restored again to continue its processing. Another approach is not to wait until a deadlock scenario actually happens, but to check beforehand that it cannot get this far: Assuming that the maximal size of a request is known, an area shared between two applications is granted exclusively to just one application, but not one part of it to the one application, and another part to the other application.

In the following, we consider the offline problem: The resource usage profiles for specific inputs of a series of applications is known a priori, or can be estimated roughly. An example of application resource profiles is given in Fig. 4. Note that in the offline case deadlocks cannot occur: We search for feasible solutions (i.e., schedules where no resource requests overlap) only.

Hardware task preemption can be used to increase the area usage. However, saving and restoring the states of the hardware applications can be very costly in time and memory. An approach that balances reconfiguration costs and efficient resource usage is to allow that requests may be delayed by the scheduler. The application keeps its currently occupied area, but remains idle until the request is fulfilled. Compare the two schedules for our example shown in Fig. 5: The schedule shown on the left hand side is a solution for scheduling the application modules without delaying requests. On the right hand side, we allow that requests are postponed. Using this

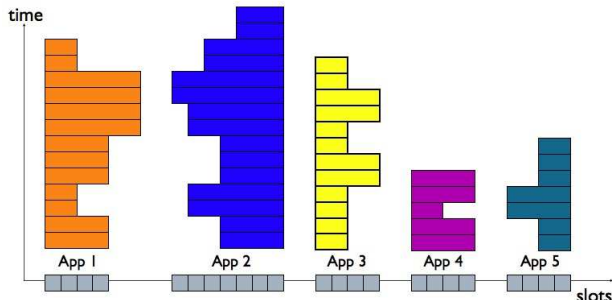

Fig. 4. Five applications modules, each with different resource demands over time for their specific inputs.

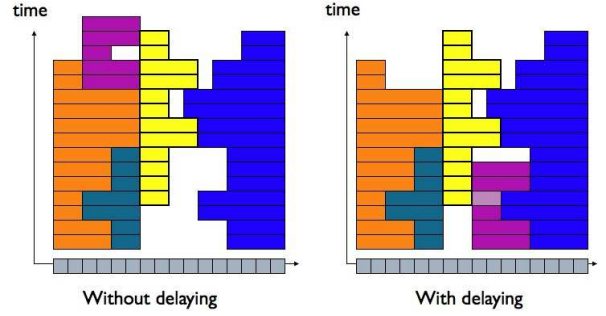

Fig. 5. Left: Schedule of the resource demands on the reconfigurable device under the assumption that running applications cannot wait for a resource grant. Right: Schedule for the same demands, but with the option to delay resource grants.

option for the fourth request of the fourth module, we achieve a better makespan.

III. PACKING APPLICATION MODULES

We consider the problem *FPGATris*: Scheduling modules whose resource requests (i.e., space on an FPGA) varies over time. This may be, for example, a router module that needs more resources if the traffic increases. We assume that a module occupies a certain number of slots on the FPGA, but requests only complete slots. Thus, we model the FPGA as a one-dimensional array. Furthermore, we assume that time is discrete; that is, requests are multiples of a fixed-size time slot. Now, scheduling a sequence of modules with time-varying resources corresponds to strip packing: The width of the strip is the number of slots on the FPGA; the height corresponds to the time axis. Thus, we use height and time synonymously. Moreover, we assume that every module occupies a base slot and extends to the left or to the right of the base slot.¹

We are allowed to *delay* a request; that is, we may stretch the modules along the time axis; see Fig. 6. Our goal is to minimize the *makespan* (i.e., the time needed to fulfill all requests). For the strip-packing problem, this goal corresponds to minimizing the height of the occupied part of the strip.

¹For convenience, we consider only the case of growing either to the left or to the right of the base slot. The generalization to both sides is straightforward.

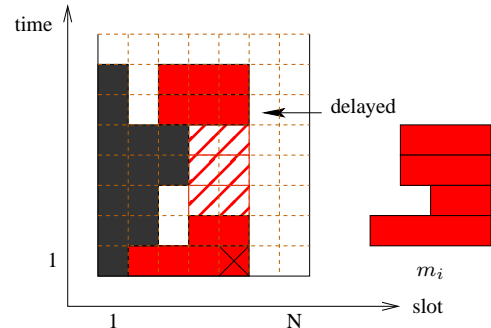

Fig. 6. We can place the module m_i at the position marked by \times (the base slot of m_i), if we *delay* the third request. That is, the second request stays on the FPGA until the third request can be fulfilled.

A. An ILP

We are given a strip of width N (e.g., an FPGA with N slots and a time axis) and want to place M modules. Each module, m_i , is given as a sequence of *requests*. Let ℓ_i denote the length of the request sequence for module m_i and (i, j) the j th request of m_i . The size of (i, j) is given by $r_{ij} \in \mathbb{Z} \setminus \{0\}$, $1 \leq j \leq \ell_i$. For $r_{ij} > 0$ the module expands to the right of the base slot, for $r_{ij} < 0$ to the left.

For the ILP, we introduce four kinds of variables:

- the *slot assignment variables*, x_{si}
- the *time assignment variables*, y_{tij}
- the *occupancy variables*, z_{stij}
- the *usage variables*, u_t

The first two types specify when and where a request is scheduled. More precisely, setting x_{si} to 1 indicates that module m_i is scheduled in slot s . Setting y_{tij} to 1 indicates that request (i, j) of module m_i is scheduled at time t . That is, module m_i occupies the following slots at time t :

$$s, \dots, s + r_{ij} - 1 \text{ for } r_{ij} > 0,$$

$$s + r_{ij} + 1, \dots, s \text{ for } r_{ij} < 0,$$

where s is the base slot of module m_i . For every i there is exactly one x_{si} with $x_{si} = 1$ and for every (i, j) there is exactly one y_{tij} with $y_{tij} = 1$.

Usually (i.e., if $|r_{ij}| > 1$) a request occupies more than one slot when executed. Moreover, if the request $(i, j + 1)$ is delayed, (i, j) remains on the FPGA for more than one time unit (i.e., it occupies more than one time row). To keep track of the occupied slots, we set z_{stij} to 1, if slot s is occupied by request (i, j) at time t . The usage variables simply specify which time steps are used.

Clearly, the FPGA's size, N , and the number of modules, M , strongly determine the size of an ILP and, in turn, the time needed to solve it. In addition, we assume that an upper bound, T , on the number of time steps is given. The closer this bound is to the optimum, the smaller the resulting ILP. This upper bound can be obtained, for example, using the tabu search in Sect. III-B4.

1) Constraints:

a) Assignment Constraints: Each request must be scheduled exactly once. That is, for every (i, j) we have to set exactly one x_{si} to 1 (to assign a slot for (i, j)) and exactly one y_{tij} (to assign a start time for (i, j)). The following constraints express these conditions:

$$\sum_{s=1}^N x_{si} = 1 \quad \forall i = 1, \dots, M, \quad (1)$$

$$\sum_{t=1}^T y_{tij} = 1 \quad \forall i = 1, \dots, M, j = 1, \dots, \ell_i. \quad (2)$$

b) Boundary Constraints: Next, we ensure that a request does not exceed the FPGA's boundary by forcing all slot assignment variables that would cause an infeasible placement to be zero.

$$\forall i, j, s = s_{\text{low}}, \dots, s_{\text{up}} : x_{si} = 0 \quad (3)$$

where

$$s_{\text{low}} := \begin{cases} N - r_{ij} + 2, & r_{ij} > 0 \\ 1, & r_{ij} < 0 \end{cases} \text{ and}$$

$$s_{\text{up}} := \begin{cases} N, & r_{ij} > 0 \\ -r_{ij} - 1, & r_{ij} < 0 \end{cases}.$$

c) Order Constraints: Now, we ensure that the processing order is maintained; that is, request (i, j) of m_i is not scheduled before request $(i, j - 1)$ is finished. For every (i, j) there is exactly one t such that $y_{tij} = 1$. Thus, summing up $t \cdot y_{tij}$ over t for fixed i and j yields the time step where request (i, j) is scheduled. This yields:

$$\sum_{t=1}^T t y_{tij} - \sum_{t=1}^T t y_{ti(j-1)} > 0 \quad \forall i, j > 0. \quad (4)$$

d) Occupancy Constraints: If $x_{si} = 1$ and $y_{tij} = 1$, the request (i, j) occupies r_{ij} slots adjacent to s at time t ; see Fig. 7. The first step to prevent other modules from overlapping with m_i is to set the appropriate occupancy variables as follows.

$$\forall i = 1, \dots, M, j = 1, \dots, \ell_i, s = 1, \dots, N, t = 1, \dots, T, s' = s_{\text{low}}, \dots, s_{\text{up}} :$$

$$x_{si} + y_{tij} - z_{s'tij} \leq 1, \quad (5)$$

with

$$s_{\text{low}} := \begin{cases} s, & r_{ij} > 0 \\ \max\{1, s + r_{ij} + 1\}, & r_{ij} < 0 \end{cases} \text{ and}$$

$$s_{\text{up}} := \begin{cases} \min\{N, s + r_{ij} - 1\}, & r_{ij} > 0 \\ s, & r_{ij} < 0 \end{cases}.$$

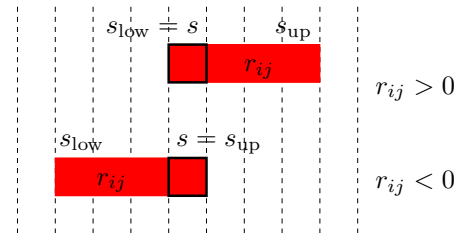

Fig. 7. Occupancy Constraints: If $x_{si} = 1$ and $y_{tij} = 1$, the request (i, j) occupies r_{ij} slots left or right to s —depending on $\text{sgn}(r_{ij})$.

e) *Exclusive Constraints*: By setting the appropriate occupancy variables with the occupancy constraints, we can ensure that requests do not overlap. We allow at most one occupancy variable for a fixed slot and a fixed time to be 1. $\forall t = 1, \dots, T, s = 1, \dots, N$:

$$\sum_{i=1}^M \sum_{j=1}^{\ell_i} z_{stij} \leq 1 \quad (6)$$

f) *Delay Constraints*: If a request $(i, j+1)$ is delayed, the preceding request (i, j) remains on the FPGA until $(i, j+1)$ is scheduled. Thus, if $z_{stij} = 1$ either $z_{s(t+1)ij}$ must be set to 1—because the module still occupies space on the FPGA—or $(i, j+1)$ is scheduled at time $t+1$; that is, $y_{(t+1)i(j+1)} = 1$ holds. The following constraints keep track of delayed requests.

$$\forall i = 1, \dots, M, j = 1, \dots, \ell_i - 1, \\ s = 1, \dots, N, t = 1, \dots, T - 1:$$

$$z_{stij} - z_{s(t+1)ij} - y_{(t+1)i(j+1)} \leq 0 \quad (7)$$

g) *Usage Constraints*: Finally, we introduce some constraints that define our usage variables. Let u_t be 1, if at least one y_{tij} is 1 or if u_{t+1} is 1.

$$\forall t = 1, \dots, T, i = 1, \dots, M, j = 1, \dots, \ell_i:$$

$$u_t - y_{tij} \geq 0 \quad (8)$$

and $\forall t = 2, \dots, T$:

$$u_{t-1} - u_t \geq 0. \quad (9)$$

2) *Objective Function*: To minimize the makespan, we use the following ILP:

$$\min \sum_{i=1}^T i u_i \quad \text{subject to} \quad \text{Eq. 1-9} \quad (10)$$

$$x_{si} \in \{0, 1\}$$

$$y_{tij} \in \{0, 1\}$$

$$z_{stij} \in \{0, 1\}$$

$$u_t \in \{0, 1\}.$$

B. Heuristic Methods

We implemented several heuristics for our problem: A simple FirstFit with and without delaying requests, and two more elaborated heuristics, BestFit and TabuSearch. Our methods pack the given modules in a semi-infinite strip. The width of the strip is given by the number of slots on the FPGA; the height of the strip corresponds to the time axis.

1) *FirstFit*: Probably the simplest heuristic is to place the modules, one by one, in a first-fit way into the strip: beginning with $s = 1$ and $t = 1$, we test for every position if the module that must be placed overlaps with already-placed modules. We choose the first position where no overlap occurs. Note that we disregard the possibility of delaying requests.

```

 $\mathcal{S} = (1, \dots, M)$ 
for  $i = 0$  to  $M/2$ 
     $found = 0$ 
    for  $j = 1$  to  $M$ 
        if  $(j, ((j+i) \bmod M) + 1)$  are not in the tabu list
            Swap items at pos.  $j$  and  $((j+i) \bmod M) + 1$  in  $\mathcal{S}$ 
            Calculate makespan of BestFit
            if makespan is the best so far then
                 $found = j$ 
                Undo swapping
        if  $found > 0$  then
            Swap pos.  $found$  and  $((found+i) \bmod M) + 1$  in  $\mathcal{S}$ 
            Store  $(found, ((found+i) \bmod M) + 1)$  in the tabu list

```

Fig. 8. Tabu Search

2) *FirstFit with delays*: This method works the same as the method above, but allows the delaying of requests. That is, if for a certain start position the requests $0, \dots, j-1$ fit into the strip without overlap, but request j does not fit in time step t' , we search for the largest $j' < j$ such that request (i, j') fits in t' and delay every request $j'' = j' + 1, \dots$ (i.e., we move them upwards in the strip); see Fig. 6.

3) *BestFit*: Similar to FirstFit with delays, we try to find a nonoverlapping position by testing every possible position. But now, we do not choose the first feasible position, but we evaluate every position as follows: We separately count the unoccupied cells left and right to the placed module and take the minimum of the these two values as a score for the given position. For example, for the placement of m_i in Fig. 6 there are 4 unoccupied cells left to m_i and 14 unoccupied cells right to m_i , yielding a value of 4 for his placement. We choose the position that yields the minimal score and break ties by preferring the (first) position with least number of delays.

To avoid that every module is placed on the left or right side (yielding a score of 0), we maintain an upper limit, t_{\max} , for the time. Before we place a new module, m_i , we increase t_{\max} by $\ell_i/2$ and try to place m_i within the given time bound. If this is not possible, we increase t_{\max} by ℓ_i and try again.

4) *TabuSearch*: BestFit inserts the modules in the given order (i.e., m_1, m_2, \dots, m_M). Obviously, the result of BestFit highly depends on the insertion order, so we may get a better result if we permute the insertion order of the modules. Thus, we use a tabu search to try several BestFit runs, each one using a different order for the insertion of modules. Starting with the sequence $\mathcal{S} = (1, \dots, M)$, we swap two items of the sequence and compute the makespan that is achieved by BestFit. More precisely, we maintain a *swapping distance*, i , ranging from $i = 0$ to $M/2$. For a fixed i , we swap the items at positions j and $((j+i) \bmod M) + 1$ for $j = 1, \dots, M$, keeping track of the best makespan achieved so far. We accept the swap that achieves the best makespan known so far. A tabu list ensures that we do not swap an already accepted pair again; see Fig. 8.

C. Experimental Results

An example instance and solutions are shown in Fig. 9. The corresponding ILP was solved in approximately 6 hours on

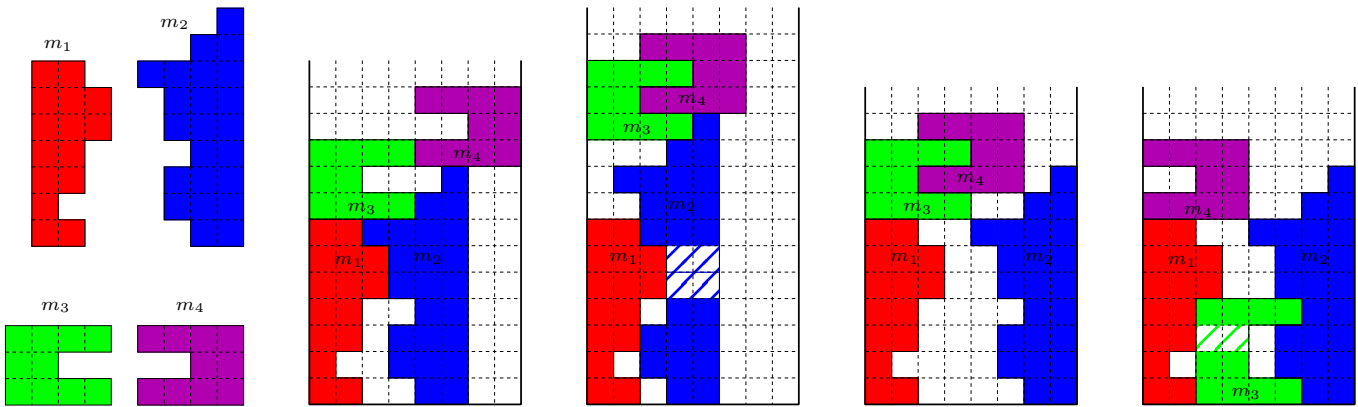

Fig. 9. From left to right: Example input and packings generated by (from left to right) FirstFit without delays, FirstFit with delays, BestFit, and TabuSearch/ILP. Delayed modules are shown hatched. Note that m_3 is packed by BestFit on top of m_1 , because this position has value 0 and fits into the strip of height $t_{\max} + \ell_3/2$. TabuSearch swaps m_3 and m_4 in the insertion order.

an Intel(R) Xeon(TM) 3.20 GHz CPU running ILOG CPLEX 10.00 under Linux. Note that TabuSearch yields the same result in less than one second.

To test our heuristics, we conducted a set of experiments. For upper limits on the size of a request, r_{\max} , ranging from 10% to 90% in steps of 10, we randomly generated sequences, each of 20 modules. For each value of r_{\max} , we shuffled 20 sequences as follows: For every module, we choose its length, ℓ_i , randomly, by normal distribution with expected value $\mu = 10$ and variance $\sigma^2 = 5$. The size for every request, r_{ij} , was chosen by normal distribution, too, with an expected value of $\mu = r_{\max}/2$ and variance $\sigma^2 = r_{\max}/4$. We present the results for $N = 50$, other FPGA widths showed similar results.

Heuristic	Average running time
FirstFit	0.25 s
FF with delays	0.33 s
BestFit	2.09 s
Tabu Search	1125.06 s

TABLE I
AVERAGE RUNNING TIME FOR OUR HEURISTICS.

Table I shows the average running time over all experiments, Fig. 10 shows the mean value over 20 runs for every heuristic and value of r_{\max} . Fig. 11 shows mean-, maximal-, and minimal values for BestFit and TabuSearch. For comparison, Fig. 10 also shows an average lower bound computed as the smallest area needed to pack all requests; that is,

$$\text{LB} = \frac{1}{N} \sum_{i=1}^M \sum_{j=1}^{\ell_i} r_{ij}.$$

Choosing the best suited strategy depends on the scenario. For systems that run the same request sequence on and on and that are produced in a large number, it may even pay off to use the ILP. Clearly, balancing computation time and quality, the tabu search is a better choice. Nevertheless, it requires that the requests are known beforehand. If this is not given, BestFit can be used, because it works in an offline scenario as well as in an online setting.

IV. CONCLUSION

Reconfigurable devices increasingly offer enough computing resources, so that in the near future, multiple applications may be executed on them concurrently, instead of just a single application. However, until now there is a general lack of research on how to successfully achieve secure and flexible execution of multiple applications on dynamically partially reconfigurable devices. We present an approach called *virtual area management*, which is heavily influenced by multitasking and operating system concepts of the software. Advantages of our concept (e.g., support for accounting of resources, resource protection, multiple scheduling and placement strategies, and a new programming model) are explained. Furthermore, challenges posed by this concept and possible solutions are discussed. Afterwards, a specific approach to virtual area management in the offline case is presented in more detail. It is based on the assumption that most applications can handle also a delayed resource grant. The corresponding optimization problem to minimize the total makespan is solved with an ILP and heuristics. Both approaches are compared in an experimental study.

The presented concept is a practicable solution to the considered important problem; the proposed methods can be applied to nowadays available reconfigurable devices. We do not rely on the assumption that saving and storing hardware task states will no longer be considered as too expensive in the future. Furthermore, programming models for reconfigurable architectures, resource accounting and protection, bitstream relocation and position independence, are all formidable research problems on their own, however the concept is compatible and extendable to different solution approaches to these problems.

REFERENCES

- [1] D. Koch, C. Haubelt, and J. Teich, "Efficient reconfigurable on-chip buses for FPGAs," in *Proc. 16th Annu. IEEE Sympos. Field-Programm. Custom Comput. Mach.*, 2008.
- [2] J. Angermeier, D. Göhringer, M. Majer, J. Teich, S. P. Fekete, and J. V. der Veen, "The Erlangen Slot Machine — A platform for interdisciplinary research in dynamically reconfigurable computing," *Information Technology*, vol. 49, pp. 143–148, 2007.

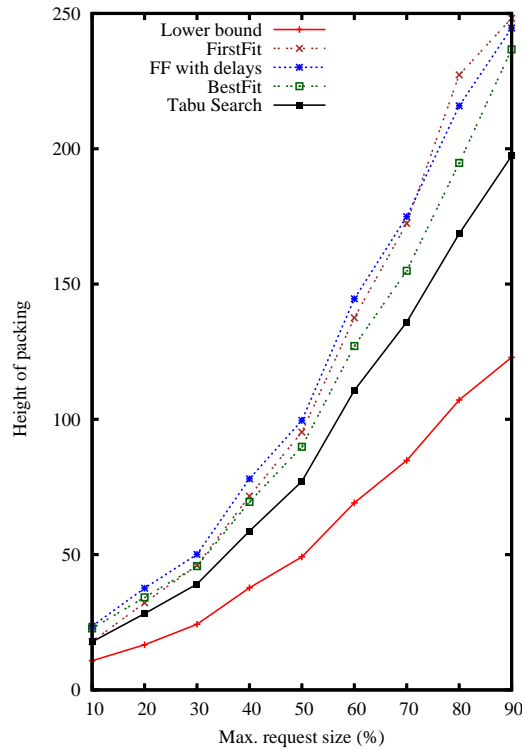

Fig. 10. A comparison of our heuristics—FirstFit (without delays), FirstFit (with delays), BestFit, and TabuSearch—in settings with different densities (i.e., maximal value for a request) averaged over 100 runs per densities. For comparison, a lower bound (ratio of total area by number of slots) is shown.

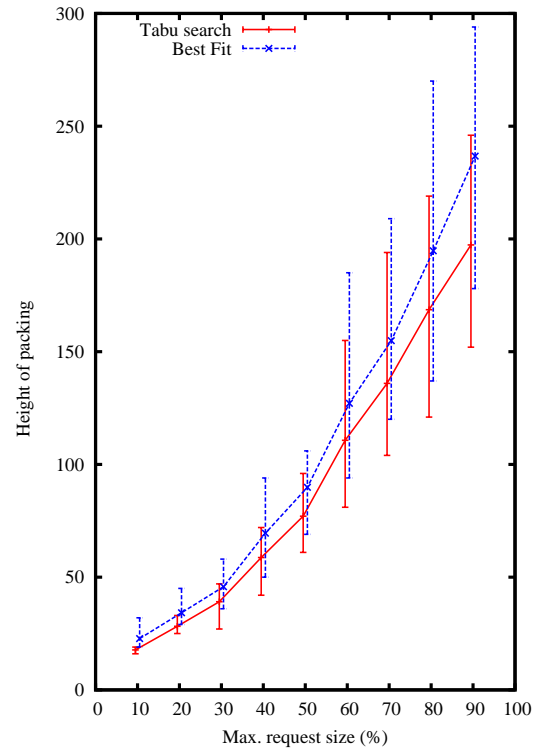

Fig. 11. Mean-, maximal-, and minimal value averaged over 100 runs per densities for BestFit and TabuSearch.

- [3] C. Bobda, M. Majer, A. Ahmadiania, T. Haller, A. Linarth, J. Teich, S. Fekete, and J. van der Veen, "The Erlangen Slot Machine: A Highly Flexible FPGA-Based Reconfigurable Platform," *IEEE Symp. on FPGAs and Custom Computing Machines (FCCM)*, pp. 319–320, 2005.
- [4] G. Brebner, "A virtual hardware operating system for the xilinx XC6200," in *Field-Programmable Logic Smart Applications, New Paradigms and Compilers*, 1996, pp. 327–336.
- [5] —, "The swappable logic unit: a paradigm for virtual hardware," in *FPGAs for Custom Computing Machines, 1997. Proceedings., The 5th Annual IEEE Symposium on*, 1997, pp. 77–86.
- [6] K. Bazargan, R. Kastner, and M. Sarrafzadeh, "Fast template placement for reconfigurable computing systems," *Design & Test of Computers, IEEE*, vol. 17, no. 1, pp. 68–83, 2000.
- [7] C. Steiger, H. Walder, M. Platzner, and L. Thiele, "Online scheduling and placement of real-time tasks to partially reconfigurable devices," in *Real-Time Systems Symposium, 2003. RTSS 2003. 24th IEEE*, 2003, pp. 224–225.
- [8] O. Diessel, H. ElGindy, M. Middendorf, H. Schmeck, and B. Schmidt, "Dynamic scheduling of tasks on partially reconfigurable FPGAs," *Computers and Digital Techniques, IEEE Proceedings*, vol. 147, no. 3, pp. 181–188, 2000.
- [9] J. Resano, D. Mozos, and F. Catthoor, "A hybrid prefetch scheduling heuristic to minimize at run-time the reconfiguration overhead of dynamically reconfigurable hardware [multimedia applications]," in *Design, Automation and Test in Europe, 2005. Proceedings*, 2005, pp. 106–111.
- [10] S. Banerjee, E. Bozorgzadeh, and N. Dutt, "Physically-aware HW-SW partitioning for reconfigurable architectures with partial dynamic reconfiguration," in *Proceedings of the 42nd annual Design Automation Conference*. ACM, 2005, pp. 335–340.
- [11] C. Steiger, H. Walder, and M. Platzner, "Operating systems for reconfigurable embedded platforms: online scheduling of real-time tasks," *IEEE Transactions on Computers*, vol. 53, no. 11, pp. 1393–1407, 2004.
- [12] G. Wigley and D. Kearney, "The development of an operating system for reconfigurable computing," in *Field-Programmable Custom Computing Machines, 2001. FCCM '01. The 9th Annual IEEE Symposium on*, 2001, pp. 249–250.
- [13] H. Walder and M. Platzner, "Reconfigurable hardware operating systems: From design concepts to realizations," in *Proceedings Of The 3rd International Conference On Engineering Of Reconfigurable Systems And Architectures (ERSA)*, pp. 284–287, 2003.
- [14] R. Cordone, F. Redaelli, M. A. Redaelli, M. D. Santambrogio, and D. Sciuto, "Partitioning and scheduling of task graphs on partially dynamically reconfigurable FPGAs," *IEEE Transact. Computer-Aided Design of Integrated Circuits and Systems*, vol. 28, pp. 662–675, 2009.
- [15] F. Redaelli, M. D. Santambrogio, and D. Sciuto, "Task scheduling with configuration prefetching and anti-fragmentation techniques on dynamically reconfigurable systems," in *Proc. 11th Conf. on Design, Automation and Test in Europe*, 2008, pp. 519–522.
- [16] J. M. Cardoso, "On combining temporal partitioning and sharing of functional units in compilation for reconfigurable architectures," *IEEE Transact. Comput.*, vol. 52, pp. 1362–1375, 2003.
- [17] S. Banerjee, E. Bozorgzadeh, and N. D. Dutt, "Integrating physical constraints in HW-SW partitioning for architectures with partial dynamic reconfiguration," *IEEE Transact. Very Large Scale Integration Systems*, vol. 14, pp. 1189–1202, 2006.
- [18] B. S. Baker, E. G. C. Jr., and R. L. Rivest, "Orthogonal packings in two dimensions," *SIAM J. Comput.*, vol. 9, pp. 846–855, 1980.
- [19] C. Kenyon and E. Rémila, "Approximate strip packing," in *Proc. 37th Annu. IEEE Sympos. Found. Comput. Sci.*, 1996, pp. 31–36.
- [20] B. S. Baker and J. S. Schwarz, "Shelf algorithms for two-dimensional packing problems," *SIAM J. Comput.*, vol. 12, pp. 508–525, 1983.
- [21] J. Csirik and G. J. Woeginger, "Shelf algorithms for on-line strip packing," *Inform. Process. Lett.*, vol. 63, pp. 171–175, 1997.
- [22] R. Breukelaar, E. D. Demaine, S. Hohenberger, H. J. Hoogeboom, W. A. Kosters, and D. Liben-Nowell, "Tetris is hard, even to approximate," *Internat. J. Comput. Geom. Appl.*, vol. 14, pp. 41–68, 2004.
- [23] Y. Azar and L. Epstein, "On two dimensional packing," *J. Algorithms*, vol. 25, pp. 290–310, 1997.
- [24] E. Coffman, Jr., P. J. Downey, and P. Winkler, "Packing rectangles in a strip," *Acta Inform.*, vol. 38, pp. 673–693, 2002.
- [25] S. P. Fekete, T. Kamphans, and N. Schweer, "Online square packing," in *Proc. 20th Algorithms and Data Structure Symposium (WADS)*, 2009, pp. 302–314.