

A Random Variable Substitution Lemma With Applications to Multiple Description Coding

Jia Wang, Jun Chen, Lei Zhao, Paul Cuff, and Haim Permuter

Abstract

We establish a random variable substitution lemma and use it to investigate the role of refinement layer in multiple description coding, which clarifies the relationship among several existing achievable multiple description rate-distortion regions. Specifically, it is shown that the El Gamal-Cover (EGC) region is equivalent to the EGC* region (an antecedent version of the EGC region) while the Venkataramani-Kramer-Goyal (VKG) region (when specialized to the 2-description case) is equivalent to the Zhang-Berger (ZB) region. Moreover, we prove that for multiple description coding with individual and hierarchical distortion constraints, the number of layers in the VKG scheme can be significantly reduced when only certain weighted sum rates are concerned. The role of refinement layer in scalable coding (a special case of multiple description coding) is also studied.

Index Terms

Contra-polymatroid, multiple description coding, rate-distortion region, scalable coding, successive refinement,

I. INTRODUCTION

A fundamental problem of multiple description coding is to characterize the rate-distortion region, which is the set of all achievable rate-distortion tuples. El Gamal and Cover (EGC) obtained an inner bound of the 2-description rate-distortion region, which is shown to be tight for the no excess rate case by Ahlswede [1]. Zhang and Berger (ZB) [23] derived a different inner bound of the 2-description rate-distortion region and showed that it contains rate-distortion tuples not included in the EGC region. The EGC region has an antecedent version, which is sometimes referred to as the EGC* region. The EGC* region was shown to be tight for the quadratic Gaussian case by Ozarow [13]. However, the EGC* region has been largely abandoned in view of the fact that it is contained in the EGC region [23]. Other work on the 2-description problem can be found in [8], [9], [12], [24]. Recent years have seen growth

Jia Wang is with the Department of Electronic Engineering, Shanghai Jiao Tong University, Shanghai 200240, China (email: jiaawang@sjtu.edu.cn).

Jun Chen is with the Department of Electrical and Computer Engineering, McMaster University, Hamilton, ON L8S 4K1, Canada (email: junchen@ece.mcmaster.ca).

Lei Zhao and Paul Cuff are with the Department of Electrical Engineering, Stanford University, Stanford, CA 94305, USA (email: {leiz,cuff}@stanford.edu).

Haim Permuter is with the Department of Electrical and Computer Engineering, Ben-Gurion University of the Negev, Beer-Sheva 84105, Israel (email: haimp@bgu.ac.il).

of interest in the general L -description problem [14], [15], [18], [19], [21]. In particular, Venkataramani, Kramer, and Goyal (VKG) [21] derived an inner bound of the L -description rate-distortion region. It is well understood that for the 2-description case both the EGC region and the ZB region subsume the EGC* region while all these three regions are contained in the VKG region; moreover, the reason that one region contains another is simply because more layers are used. Indeed, the ZB scheme has one more common description layer than the EGC* scheme while the EGC scheme and the VKG scheme have one more refinement layer than the EGC* scheme and the ZB scheme, respectively. Although it is known [23] that the EGC* scheme can be strictly improved via the inclusion of a common description layer, it is still unclear whether the refinement layer has the same effect. We shall show that in fact the EGC region is equivalent to the EGC* region and the VKG region is equivalent to the ZB region; as a consequence, the refinement layer can be safely removed.

An important special case of the 2-description problem is called scalable coding, also known as successive refinement¹. The rate-distortion region of scalable coding has been characterized by Koshelev [10] [11], Equitz and Cover [6] for the no rate loss case and by Rimoldi [16] for the general case. In scalable coding, the second description is not required to reconstruct the source; instead, it serves as a refinement layer to improve the first description. However, it is clearly of interest to know whether the refinement layer itself in an optimal scalable coding scheme can be useful, i.e., whether one can achieve a nontrivial distortion using the refinement layer alone. This problem is closely related, but not identical, to multiple description coding with no excess rate.

To the end of understanding the role of refinement layer in multiple description coding as well as scalable coding, we need the following random variable substitution lemma.

Lemma 1: Let U , V , and W be jointly distributed random variables taking values in finite sets \mathcal{U} , \mathcal{V} , and \mathcal{W} , respectively. There exist a random variable Z , taking values in a finite set \mathcal{Z} with $|\mathcal{Z}| \leq |\mathcal{V}||\mathcal{W}| - 1$, and a function $f : \mathcal{V} \times \mathcal{Z} \rightarrow \mathcal{W}$ such that

- 1) Z is independent of V ;
- 2) $W = f(V, Z)$;
- 3) $U - (V, W) - Z$ form a Markov chain.

The proof of Lemma 1 is given in Appendix I. Roughly speaking, this lemma states that one can remove random variable W by introducing random variable Z and deterministic function f . It will be seen in the context of multiple description coding that Z can be incorporated into other random variables due to its special property, which results in a reduction of the number of random variables.

The remainder of this paper is devoted to the applications of the random variable substitution lemma to multiple description coding and scalable coding. In Section II, we show that the EGC region is equivalent to the EGC* region and the ZB region includes the EGC region. We examine the general L -description problem in Section III. It is shown that the final refinement layer in the VKG scheme can be removed. This result implies that the VKG region, when specialized to the 2-description case, is equivalent to the ZB region. Furthermore, we prove that for

¹The notion of successive refinement is sometimes used in the more restrictive no rate loss scenario.

multiple description coding with individual and hierarchical distortion constraints, the number of layers in the VKG scheme can be significantly reduced when only certain weighted sum rates are concerned. We study scalable coding with an emphasis on the role of refinement layer in Section IV. Section V contains some concluding remarks.

II. APPLICATIONS TO THE 2-DESCRIPTION CASE

We shall first give a formal definition of the multiple description rate-distortion region. Let $\{X(t)\}_{t=1}^{\infty}$ be an i.i.d. process with marginal distribution p_X on \mathcal{X} , and $d : \mathcal{X} \times \hat{\mathcal{X}} \rightarrow [0, \infty)$ be a distortion measure, where \mathcal{X} and $\hat{\mathcal{X}}$ are finite sets. Define $\mathcal{I}_L = \{1, \dots, L\}$ for any positive integer L .

Definition 1: A rate-distortion tuple $(R_1, \dots, R_L, D_{\mathcal{K}}, \emptyset \subset \mathcal{K} \subseteq \mathcal{L})$ is said to be achievable if for any $\epsilon > 0$, there exist encoding functions $f_k^{(n)} : \mathcal{X}^n \rightarrow \mathcal{C}_k^{(n)}$, $k \in \mathcal{I}_L$, and decoding functions $g_{\mathcal{K}}^{(n)} : \prod_{k \in \mathcal{K}} \mathcal{C}_k^{(n)} \rightarrow \hat{\mathcal{X}}^n$, $\emptyset \subset \mathcal{K} \subseteq \mathcal{I}_L$, such that

$$\begin{aligned} \frac{1}{n} \log |\mathcal{C}_k^{(n)}| &\leq R_k + \epsilon, \quad k \in \mathcal{I}_L, \\ \frac{1}{n} \sum_{t=1}^n \mathbb{E}[d(X(t), \hat{X}_{\mathcal{K}}(t))] &\leq D_{\mathcal{K}} + \epsilon, \quad \emptyset \subset \mathcal{K} \subseteq \mathcal{I}_L, \end{aligned}$$

for all sufficiently large n , where $\hat{X}_{\mathcal{K}}^n = g_{\mathcal{K}}^{(n)}(f_k^{(n)}(X^n), k \in \mathcal{K})$. The multiple description rate-distortion region \mathcal{RD}_{MD} is the set of all achievable rate-distortion tuples.

We shall focus on the 2-description case (i.e., $L = 2$) in this section. The following two inner bounds of \mathcal{RD}_{MD} are attributed to El Gamal and Cover.

The EGC* region $\mathcal{RD}_{\text{EGC}^*}$ is the convex closure of the set of quintuples $(R_1, R_2, D_{\{1\}}, D_{\{2\}}, D_{\{1,2\}})$ for which there exist auxiliary random variables $X_{\{1\}}$ and $X_{\{2\}}$, jointly distributed with X , and functions $\phi_{\mathcal{K}}, \emptyset \subset \mathcal{K} \subseteq \{1, 2\}$, such that

$$\begin{aligned} R_k &\geq I(X; X_{\{k\}}), \quad k \in \{1, 2\}, \\ R_1 + R_2 &\geq I(X; X_{\{1\}}, X_{\{2\}}) + I(X_{\{1\}}; X_{\{2\}}), \\ D_{\{k\}} &\geq \mathbb{E}[d(X, \phi_{\{i\}}(X_{\{i\}}))], \quad k \in \{1, 2\}, \\ D_{\{1,2\}} &\geq \mathbb{E}[d(X, \phi_{\{1,2\}}(X_{\{1\}}, X_{\{2\}}))]. \end{aligned}$$

The EGC region $\mathcal{RD}_{\text{EGC}}$ is the convex closure of the set of quintuples $(R_1, R_2, D_{\{1\}}, D_{\{2\}}, D_{\{1,2\}})$ for which there exist auxiliary random variables $X_{\mathcal{K}}, \emptyset \subset \mathcal{K} \subseteq \{1, 2\}$, jointly distributed with X , such that

$$R_k \geq I(X; X_{\{k\}}), \quad k \in \{1, 2\}, \tag{1}$$

$$R_1 + R_2 \geq I(X; X_{\{1\}}, X_{\{2\}}, X_{\{1,2\}}) + I(X_{\{1\}}; X_{\{2\}}), \tag{2}$$

$$D_{\mathcal{K}} \geq \mathbb{E}[d(X, X_{\mathcal{K}})], \quad \emptyset \subset \mathcal{K} \subseteq \{1, 2\}. \tag{3}$$

To see the connection between these two inner bounds, we shall write the EGC region in an alternative form. It can be verified that the EGC region is equivalent to the set of quintuples $(R_1, R_2, D_{\{1\}}, D_{\{2\}}, D_{\{1,2\}})$ for which there

exist auxiliary random variables $X_{\mathcal{K}}$, $\emptyset \subset \mathcal{K} \subseteq \{1, 2\}$, jointly distributed with X , and functions $\phi_{\mathcal{K}}$, $\emptyset \subset \mathcal{K} \subseteq \{1, 2\}$, such that

$$\begin{aligned} R_k &\geq I(X; X_{\{k\}}), \quad k \in \{1, 2\}, \\ R_1 + R_2 &\geq I(X; X_{\{1\}}, X_{\{2\}}, X_{\{1,2\}}) + I(X_{\{1\}}; X_{\{2\}}), \\ D_{\{k\}} &\geq \mathbb{E}[d(X, \phi_{\{k\}}(X_{\{k\}}))], \quad k \in \{1, 2\}, \\ D_{\{1,2\}} &\geq \mathbb{E}[d(X, \phi_{\{1,2\}}(X_{\{1\}}, X_{\{2\}}, X_{\{1,2\}}))]. \end{aligned}$$

It is easy to see from this alternative form of the EGC region that the only difference from the EGC* region is the additional random variable $X_{\{1,2\}}$, which corresponds to a refinement layer; by setting $X_{\{1,2\}}$ to be constant (i.e., removing the refinement layer), we recover the EGC* region. Therefore, the EGC* region is contained in the EGC region. It is natural to ask whether the refinement layer leads to a strict improvement. The answer turns out to be negative as shown by the following theorem, which states that the two regions are in fact equivalent.

Theorem 1: $\mathcal{RD}_{\text{EGC}^*} = \mathcal{RD}_{\text{EGC}}$.

Proof: In view of the fact that $\mathcal{RD}_{\text{EGC}^*} \subseteq \mathcal{RD}_{\text{EGC}}$, it suffices to prove $\mathcal{RD}_{\text{EGC}} \subseteq \mathcal{RD}_{\text{EGC}^*}$.

For any fixed $p_{X X_{\{1\}} X_{\{2\}} X_{\{1,2\}}}$, the region specified by (1)-(3) has two vertices

$$\begin{aligned} v_1 &: (R_1(v_1), R_2(v_1), D_{\{1\}}(v_1), D_{\{2\}}(v_1), D_{\{1,2\}}(v_1)), \\ v_2 &: (R_1(v_2), R_2(v_2), D_{\{1\}}(v_2), D_{\{2\}}(v_2), D_{\{1,2\}}(v_2)), \end{aligned}$$

where

$$\begin{aligned} R_1(v_1) &= I(X; X_{\{1\}}), \\ R_2(v_1) &= I(X; X_{\{2\}}, X_{\{1,2\}} | X_{\{1\}}) + I(X_{\{1\}}; X_{\{2\}}), \\ R_1(v_2) &= I(X; X_{\{1\}}, X_{\{1,2\}} | X_{\{2\}}) + I(X_{\{1\}}; X_{\{2\}}), \\ R_2(v_2) &= I(X; X_{\{2\}}), \\ D_{\mathcal{K}}(v_1) &= D_{\mathcal{K}}(v_2) = \mathbb{E}[d(X, X_{\mathcal{K}})], \quad \emptyset \subset \mathcal{K} \subseteq \{1, 2\}. \end{aligned}$$

We just need to show that both vertices are contained in the EGC* region. By symmetry, we shall only consider vertex v_1 .

It follows from Lemma 1 that there exist a random variable Z , jointly distributed with $(X, X_{\{1\}}, X_{\{2\}}, X_{\{1,2\}})$, and a function f such that

- 1) Z is independent of $(X_{\{1\}}, X_{\{2\}})$;
- 2) $X_{\{1,2\}} = f(X_{\{1\}}, X_{\{2\}}, Z)$;
- 3) $X - (X_{\{1\}}, X_{\{2\}}, X_{\{1,2\}}) - Z$ form a Markov chain.

By the fact that $X - (X_{\{1\}}, X_{\{2\}}, X_{\{1,2\}}) - Z$ form a Markov chain and that $X_{\{1,2\}}$ is a deterministic function of $(X_{\{1\}}, X_{\{2\}}, Z)$, we have

$$\begin{aligned} I(X; X_{\{2\}}, X_{\{1,2\}} | X_{\{1\}}) &= I(X; X_{\{2\}}, X_{\{1,2\}}, Z | X_{\{1\}}) \\ &= I(X; X_{\{2\}}, Z | X_{\{1\}}). \end{aligned}$$

Moreover, since Z is independent of $(X_{\{1\}}, X_{\{2\}})$, it follows that

$$I(X_{\{1\}}; X_{\{2\}}) = I(X_{\{1\}}; X_{\{2\}}, Z).$$

By setting $X'_{\{2\}} = (X_{\{2\}}, Z)$, we can rewrite the coordinates of v_1 as

$$\begin{aligned} R_1(v_1) &= I(X; X_{\{1\}}), \\ R_2(v_1) &= I(X; X_{\{1\}}, X'_{\{2\}}) + I(X_{\{1\}}; X'_{\{2\}}), \\ D_{\{1\}}(v_1) &= \mathbb{E}[d(X, \phi_{\{1\}}(X_{\{1\}}))], \\ D_{\{2\}}(v_1) &= \mathbb{E}[d(X, \phi_{\{2\}}(X'_{\{2\}}))], \\ D_{\{1,2\}}(v_1) &= \mathbb{E}[d(X, \phi_{\{1,2\}}(X_{\{1\}}, X'_{\{2\}}))], \end{aligned}$$

where $\phi_{\{1\}}(X_{\{1\}}) = X_{\{1\}}$, $\phi_{\{2\}}(X'_{\{2\}}) = X_{\{2\}}$, and $\phi_{\{1,2\}}(X_{\{1\}}, X'_{\{2\}}) = f(X_{\{1\}}, X_{\{2\}}, Z) = X_{\{1,2\}}$. Therefore, it is clear that vertex v_1 is contained in the EGC* region. The proof is complete. \blacksquare

Remark: It is worth noting that the proof of Theorem 1 implicitly provides cardinality bounds for the auxiliary random variables of the EGC* region.

Now we shall proceed to discuss the ZB region, which is also an inner bound of \mathcal{RD}_{MD} . The ZB region \mathcal{RD}_{ZB} is the set of quintuples $(R_1, R_2, D_{\{1\}}, D_{\{2\}}, D_{\{1,2\}})$ for which there exist auxiliary random variables $X_\emptyset, X_{\{1\}}$, and $X_{\{2\}}$, jointly distributed with X , and functions $\phi_{\mathcal{K}}, \emptyset \subset \mathcal{K} \subseteq \{1, 2\}$, such that

$$\begin{aligned} R_k &\geq I(X; X_\emptyset, X_{\{k\}}), \quad k \in \{1, 2\}, \\ R_1 + R_2 &\geq 2I(X; X_\emptyset) + I(X; X_{\{1\}}, X_{\{2\}} | X_\emptyset) + I(X_{\{1\}}; X_{\{2\}} | X_\emptyset), \\ D_{\{k\}} &\geq \mathbb{E}[d(X, \phi_{\{k\}}(X_\emptyset, X_{\{k\}}))], \quad k \in \{1, 2\}, \\ D_{\{1,2\}} &\geq \mathbb{E}[d(X, \phi_{\{1,2\}}(X_\emptyset, X_{\{1\}}, X_{\{2\}}))]. \end{aligned}$$

Note that the ZB region is a convex set. It is easy to see from the definition of the ZB region that its only difference from the EGC* region is the additional random variable X_\emptyset , which corresponds to a common description layer; by setting X_\emptyset to be constant (i.e., removing the common description layer), we recover the EGC* region. Therefore, the EGC* region is contained in the ZB region, and the following result is an immediate consequence of Theorem 1.

Corollary 1: $\mathcal{RD}_{\text{EGC}} \subseteq \mathcal{RD}_{\text{ZB}}$.

Remark: Since the ZB region contains rate-distortion tuples not in the EGC region as shown in [23], the inclusion can be strict.

III. APPLICATIONS TO THE L -DESCRIPTION CASE

The general L -description problem turns out to be considerably more complex than the 2-description case. The difficulty might be attributed to the following fact. For any two non-empty subsets of $\{1, 2\}$, either one contains the other or they are disjoint; however, this is not true for subsets of \mathcal{I}_L when $L > 2$. Indeed, this tree structure of distortion constraints is a fundamental feature that distinguishes the 2-description problem from the general L -description problem.

The VKG region [21], which is a natural combination and extension of the EGC region and the ZB region, is an inner bound of the L -description rate-distortion region. We shall show that the final refinement layer in the VKG scheme is dispensable, which implies that the VKG region, when specialized to the 2-description case, coincides with the ZB region. We formulate the problem of multiple description coding with individual and hierarchical distortion constraints, which is a special case of tree-structured distortion constraints, and show that in this setting the number of layers in the VKG scheme can be significantly reduced when only certain weighted sum rates are concerned. It is worth noting that the VKG scheme is not the only scheme known for the L -description problem. Indeed, there are several other schemes in the literature [14], [15], [18] which can outperform the VKG scheme in certain scenarios where the distortion constraints do not exhibit a tree structure. However, the VKG scheme remains to be the most natural one for tree-structured distortion constraints.

We shall adopt the notation in [21]. For any set \mathcal{A} , let $2^{\mathcal{A}}$ be the power set of \mathcal{A} . Given a collection of sets \mathcal{B} , we define $X_{(\mathcal{B})} = \{X_{\mathcal{A}} : \mathcal{A} \in \mathcal{B}\}$. Note that X_{\emptyset} (which is a random variable) should not be confused with $X_{(\emptyset)}$ (which is interpreted as a constant). We use $R_{\mathcal{K}}$ to denote $\sum_{k \in \mathcal{K}} R_k$ for $\emptyset \subset \mathcal{K} \subseteq \mathcal{I}_L$.

The VKG region $\mathcal{RD}_{\text{VKG}}$ is the set of rate-distortion tuples $(R_1, \dots, R_L, D_{\mathcal{K}}, \emptyset \subset \mathcal{K} \subseteq \mathcal{I}_L)$ for which there exist auxiliary random variables $X_{\mathcal{K}}$, $\mathcal{K} \subseteq \mathcal{I}_L$, jointly distributed with X , and functions $\phi_{\mathcal{K}}, \emptyset \subset \mathcal{K} \subseteq \mathcal{I}_L$, such that

$$R_{\mathcal{K}} \geq \psi(\mathcal{K}), \quad \emptyset \subset \mathcal{K} \subseteq \mathcal{I}_L, \quad (4)$$

$$D_{\mathcal{K}} \geq \mathbb{E}[d_{\mathcal{K}}(X, \phi_{\mathcal{K}}(X_{(2^{\mathcal{K}})}))], \quad \emptyset \subset \mathcal{K} \subseteq \mathcal{I}_L, \quad (5)$$

where

$$\psi(\mathcal{K}) = (|\mathcal{K}| - 1)I(X; X_{\emptyset}) - H(X_{(2^{\mathcal{K}})}|X) + \sum_{\mathcal{A} \subseteq \mathcal{K}} H(X_{\mathcal{A}}|X_{(2^{\mathcal{A}} - \{\mathcal{A}\})}).$$

Note that the VKG region is a convex set. In fact, reference [21] contains a weak version and a strong version of the VKG region, and the one given here is in a slightly different form from those in [21]. Specifically, one can get the weak version in [21] by replacing (5) with $D_{\mathcal{K}} \geq \mathbb{E}[d_{\mathcal{K}}(X, X_{\mathcal{K}})]$, and get the strong version in [21] by replacing (5) with $D_{\mathcal{K}} \geq \mathbb{E}[d_{\mathcal{K}}(X, \phi_{\mathcal{K}}(X_{\mathcal{K}}))]$. It is easy to verify that the strong version is equivalent to the one given here while both of them are at least as large as the weak version; moreover, all these three versions are equivalent when $L = 2$.

We shall first give a structural characterization of the VKG region.

Lemma 2: For any fixed $p_{XX_{(2^{\mathcal{I}_L})}}$, the rate region $\{(R_1, \dots, R_L) : R_{\mathcal{K}} \geq \psi(\mathcal{K}), \emptyset \subset \mathcal{K} \subseteq \mathcal{I}_L\}$ is a contra-polymatroid.

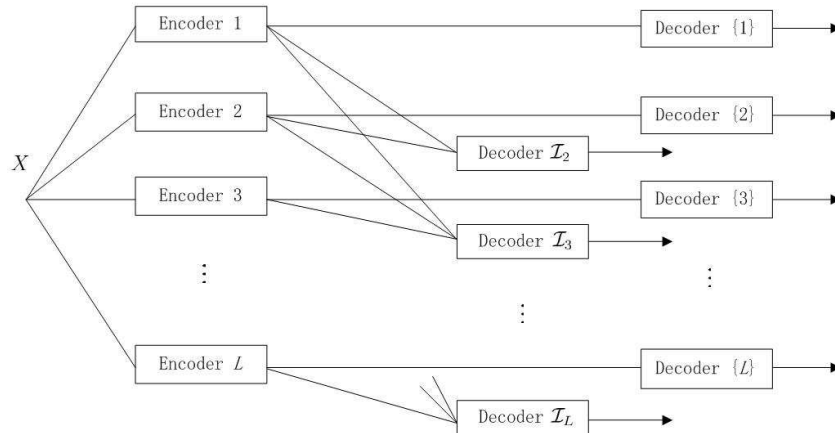

Fig. 1. Multiple description coding with individual and hierarchical distortion constraints.

Proof: See Appendix II. ■

Note that the random variable $X_{\mathcal{I}_L}$ corresponds to the final refinement layer in the VKG scheme. Now we proceed to show that this refinement layer can be removed. Define the VKG* region $\mathcal{RD}_{\text{VKG}^*}$ as the VKG region with $X_{\mathcal{I}_L}$ set to be a constant.

Theorem 2: $\mathcal{RD}_{\text{VKG}^*} = \mathcal{RD}_{\text{VKG}}$.

Proof: The proof is given in Appendix III. ■

A direct consequence of Theorem 2 is that the VKG region, when specialized to the 2-description case, is equivalent to the ZB region.

Corollary 2: For the 2-description problem, $\mathcal{RD}_{\text{ZB}} = \mathcal{RD}_{\text{VKG}}$.

Remark: For the 2-description VKG region, the cardinality bound for X_\emptyset can be derived by invoking the supporting lemma [4] while all the other auxiliary random variables can be assumed, with no loss of generality, to be defined on the reconstruction alphabet $\hat{\mathcal{X}}$. Therefore, one can deduce cardinality bounds for the auxiliary random variables of the ZB region by leveraging Corollary 2.

We can see that for the VKG* region, the number of auxiliary random variables is exactly the same as the number of distortion constraints. Intuitively, the number of auxiliary random variables can be further reduced if we remove certain distortion constraints. Somewhat surprisingly, we shall show that in some cases the number of auxiliary random variables can be significantly less than the number of distortion constraints.

For any nonnegative integer k , define $\mathcal{H}_k = \emptyset$ if $k = 0$, $\mathcal{H}_k = \{\{1\}\}$ if $k = 1$, and $\mathcal{H}_k = \{\{1\}, \dots, \{k\}, \mathcal{I}_2, \dots, \mathcal{I}_k\}$ if $k \geq 2$. Multiple description coding with individual and hierarchical distortion constraints (see Fig. 1) refers to the scenario where only the following distortion constraints: $D_{\mathcal{K}}, \mathcal{K} \in \mathcal{H}_L$, are imposed. Specializing the VKG region to this setting, we can define the VKG region for multiple description coding with individual and hierarchical distortion constraints $\mathcal{RD}_{\text{IH-VKG}}$ as the set of rate-distortion tuples $(R_1, \dots, R_L, D_{\mathcal{K}}, \mathcal{K} \in \mathcal{H}_L)$ for which there

exist auxiliary random variables $X_{\mathcal{K}}$, $\mathcal{K} \subseteq \mathcal{I}_L$, jointly distributed with X , and functions $\phi_{\mathcal{K}}$, $\mathcal{K} \in \mathcal{H}_L$, such that

$$\begin{aligned} R_{\mathcal{K}} &\geq \psi(\mathcal{K}), \quad \emptyset \subset \mathcal{K} \subseteq \mathcal{I}_L, \\ D_{\mathcal{K}} &\geq \mathbb{E}[d_{\mathcal{K}}(X, \phi_{\mathcal{K}}(X_{(2^{\mathcal{K}})}))], \quad \mathcal{K} \in \mathcal{H}_L. \end{aligned}$$

Define $\mathcal{R}_{\text{IH-VKG}}(D_{\mathcal{K}}, \mathcal{K} \in \mathcal{H}_L) = \{(R_1, \dots, R_L) : (R_1, \dots, R_L, D_{\mathcal{K}}, \mathcal{K} \in \mathcal{H}_L) \in \mathcal{RD}_{\text{IH-VKG}}\}$. It is observed in [3] that for the quadratic Gaussian case, the number of auxiliary random variables can be significantly reduced when only certain supporting hyperplanes of $\mathcal{R}_{\text{IH-VKG}}(D_{\mathcal{K}}, \mathcal{K} \in \mathcal{H}_L)$ are concerned. We shall show that this phenomenon is not restricted to the quadratic Gaussian case.

Theorem 3: For any $\alpha_1 \geq \dots \alpha_L \geq 0$, we have

$$\begin{aligned} &\min_{(R_1, \dots, R_L) \in \mathcal{R}_{\text{IH-VKG}}(D_{\mathcal{K}}, \mathcal{K} \in \mathcal{H}_L)} \sum_{k=1}^L \alpha_k R_k \\ &= \min_{p_{X_{\emptyset} X_{\{1\}} \dots X_{\{L\}} | X}, \phi_{\mathcal{K}}, \mathcal{K} \in \mathcal{H}_L} \sum_{k=1}^L \alpha_k [I(X; X_{\emptyset}) + I(X, \{X_{\{i\}}\}_{i=1}^{k-1}; X_{\{k\}} | X_{\emptyset})], \end{aligned} \quad (6)$$

where the minimization in (6) is over $p_{X_{\emptyset} X_{\{1\}} \dots X_{\{L\}} | X}$, and $\phi_{\mathcal{K}}$, $\mathcal{K} \in \mathcal{H}_L$, subject to the constraints

$$\begin{aligned} D_{\{k\}} &\geq \mathbb{E}[d(X, \phi_{\{k\}}(X_{\emptyset}, X_{\{k\}}))], \quad k \in \mathcal{I}_L, \\ D_{\mathcal{I}_k} &\geq \mathbb{E}[d(X, \phi_{\mathcal{I}_k}(X_{\emptyset}, X_{\{1\}}, \dots, X_{\{k\}}))], \quad k \in \mathcal{I}_L - \{1\}. \end{aligned}$$

Proof: The proof of Theorem 3 is given in Appendix IV. ■

Corollary 3: For any $\alpha_1 \geq \dots \alpha_L \geq 0$, we have

$$\begin{aligned} &\min_{(R_1, \dots, R_L) \in \mathcal{R}_{\text{IH-VKG}}(D_{\mathcal{K}}, \mathcal{K} \in \mathcal{H}_L)} \sum_{k=1}^L \alpha_k R_k \\ &= \min_{p_{X_{\emptyset} X_{(\mathcal{H}_L)} | X}} \sum_{k=1}^L \alpha_k [I(X; X_{\emptyset}) + I(X_{(\mathcal{H}_{k-1})}; X_{\{k\}} | X_{\emptyset}) + I(X; X_{\{k\}}, X_{\mathcal{I}_k} | X_{\emptyset}, X_{(\mathcal{H}_{k-1})})], \end{aligned} \quad (7)$$

where the minimization in (7) is over $p_{X_{\emptyset} X_{(\mathcal{H}_L)} | X}$ subject to the constraints

$$D_{\mathcal{K}} \geq \mathbb{E}[d(X, X_{\mathcal{K}})], \quad \mathcal{K} \in \mathcal{H}_L.$$

Proof: See Appendix V. ■

Remark: It should be noted that $X_{\mathcal{K}}$, $\mathcal{K} \in \mathcal{H}_L$, in (7) are defined on the reconstruction alphabet $\hat{\mathcal{X}}$; moreover, for X_{\emptyset} in (7), the cardinality bound can be easily derived by invoking the support lemma [4]. In view of the proof of Corollary 3, one can derive cardinality bounds for the auxiliary random variables in (6) by leveraging the cardinality bounds for the auxiliary random variables in (7). This explains why ‘‘min’’ instead of ‘‘inf’’ is used in (6).

A special case of multiple description coding with individual and hierarchical distortion constraints is called multiple description coding with individual and central distortion constraints [3], [22], where only the individual distortion constraints $D_{\{k\}}$, $k \in \mathcal{I}_L$, and the central distortion constraint $D_{\mathcal{I}_L}$ are imposed. Let $\mathcal{G}_L = \{\{1\}, \dots, \{L\}, \mathcal{I}_L\}$. We can define the VKG region for multiple description coding with individual and central distortion constraints $\mathcal{RD}_{\text{IC-VKG}}$ as the set of rate-distortion tuples $(R_1, \dots, R_L, D_{\mathcal{K}}, \mathcal{K} \in \mathcal{G}_L)$ for which there exist auxiliary random

variables $X_{\mathcal{K}}$, $\mathcal{K} \subseteq \mathcal{I}_L$, jointly distributed with X , and functions $\phi_{\mathcal{K}}$, $\mathcal{K} \in \mathcal{G}_L$, such that

$$\begin{aligned} R_{\mathcal{K}} &\geq \psi(\mathcal{K}), \quad \emptyset \subset \mathcal{K} \subseteq \mathcal{I}_L, \\ D_{\mathcal{K}} &\geq \mathbb{E}[d_{\mathcal{K}}(X, \phi_{\mathcal{K}}(X_{(2^{\mathcal{K}})}))], \quad \mathcal{K} \in \mathcal{G}_L. \end{aligned}$$

Define $\mathcal{R}_{\text{IC-VKG}}(D_{\mathcal{K}}, \mathcal{K} \in \mathcal{G}_L) = \{(R_1, \dots, R_L) : (R_1, \dots, R_L, D_{\mathcal{K}}, \mathcal{K} \in \mathcal{G}_L) \in \mathcal{RD}_{\text{IC-VKG}}\}$. The following result is a simple consequence of Theorem 3 and Corollary 3.

Corollary 4: $\mathcal{RD}_{\text{IC-VKG}}$ is equivalent to the set of rate-distortion tuples $(R_1, \dots, R_L, D_{\mathcal{K}}, \mathcal{K} \in \mathcal{G}_L)$ for which there exist auxiliary random variables $X_{\emptyset}, X_{\{k\}}, k \in \mathcal{I}_L$, jointly distributed with X , and functions $\phi_{\mathcal{K}}, \mathcal{K} \in \mathcal{G}_L$, such that

$$\begin{aligned} R_{\mathcal{K}} &\geq |\mathcal{K}|I(X; X_{\emptyset}) - H(\{X_{\{k\}}\}_{k \in \mathcal{K}}|X, X_{\emptyset}) + \sum_{k \in \mathcal{K}} H(X_{\{k\}}|X_{\emptyset}), \quad \emptyset \subset \mathcal{K} \subseteq \mathcal{I}_L, \\ D_{\{k\}} &\geq \mathbb{E}[d(X, \phi_{\{k\}}(X_{\emptyset}, X_{\{k\}}))], \quad k \in \mathcal{I}_L, \\ D_{\mathcal{I}_L} &\geq \mathbb{E}[d(X, \phi_{\mathcal{I}_L}(X_{\emptyset}, X_{\{1\}}, \dots, X_{\{L\}}))]. \end{aligned}$$

$\mathcal{RD}_{\text{IC-VKG}}$ is also equivalent to the set of rate-distortion tuples $(R_1, \dots, R_L, D_{\mathcal{K}}, \mathcal{K} \in \mathcal{G}_L)$ for which there exist auxiliary random variables $X_{\emptyset}, X_{\mathcal{K}}, \mathcal{K} \in \mathcal{G}_L$, jointly distributed with X , and functions $\phi_{\mathcal{K}}, \mathcal{K} \in \mathcal{G}_L$, such that

$$\begin{aligned} R_{\mathcal{K}} &\geq |\mathcal{K}|I(X; X_{\emptyset}) - H(\{X_{\{k\}}\}_{k \in \mathcal{K}}|X, X_{\emptyset}) + \sum_{k \in \mathcal{K}} H(X_{\{k\}}|X_{\emptyset}), \quad \emptyset \subset \mathcal{K} \subset \mathcal{I}_L, \\ R_{\mathcal{I}_L} &\geq LI(X; X_{\emptyset}) - H(\{X_{\{k\}}\}_{k \in \mathcal{I}_L}|X, X_{\emptyset}) + \sum_{k=1}^L H(X_{\{k\}}|X_{\emptyset}) + I(X; X_{\mathcal{I}_L}|X_{\emptyset}, \{X_{\{k\}}\}_{k \in \mathcal{I}_L}), \\ D_{\mathcal{K}} &\geq \mathbb{E}[d(X, X_{\mathcal{K}})], \quad \mathcal{K} \in \mathcal{G}_L. \end{aligned}$$

Moreover, for any $(\alpha_1, \dots, \alpha_L) \in \mathbb{R}_+^L$, let π be a permutation on \mathcal{I}_L such that $\alpha_{\pi(1)} \geq \dots \geq \alpha_{\pi(L)}$; we have

$$\begin{aligned} &\min_{(R_1, \dots, R_L) \in \mathcal{R}_{\text{IC-VKG}}(D_{\mathcal{K}}, \mathcal{K} \in \mathcal{G}_L)} \sum_{k=1}^L \alpha_k R_k \\ &= \min_{p_{X_{\emptyset} X_{\{1\}} \dots X_{\{L\}}|X}, \phi_{\mathcal{K}}, \mathcal{K} \in \mathcal{G}_L} \sum_{k=1}^L \alpha_{\pi(k)} [I(X; X_{\emptyset}) + I(X, \{X_{\pi(i)}\}_{i=1}^{k-1}; X_{\{\pi(k)\}}|X_{\emptyset})] \end{aligned} \quad (8)$$

$$= \min_{p_{X_{\emptyset} X_{(\mathcal{G}_L)}|X}} \sum_{k=1}^L \alpha_{\pi(k)} [I(X; X_{\emptyset}) + I(X, \{X_{\pi(i)}\}_{i=1}^{k-1}; X_{\{\pi(k)\}}|X_{\emptyset})] + \alpha_{\pi(L)} I(X; X_{\mathcal{I}_L}|X_{\emptyset}, \{X_{\{k\}}\}_{k \in \mathcal{I}_L}), \quad (9)$$

where the minimization in (8) is over $p_{X_{\emptyset} X_{\{1\}} \dots X_{\{L\}}|X}$, and $\phi_{\mathcal{K}}, \mathcal{K} \in \mathcal{G}_L$, subject to the constraints

$$\begin{aligned} D_{\{k\}} &\geq \mathbb{E}[d(X, \phi_{\{k\}}(X_{\emptyset}, X_{\{k\}}))], \quad k \in \mathcal{I}_L, \\ D_{\mathcal{I}_L} &\geq \mathbb{E}[d(X, \phi_{\mathcal{I}_L}(X_{\emptyset}, X_{\{1\}}, \dots, X_{\{L\}}))], \end{aligned}$$

while the minimization in (9) is over $p_{X_{\emptyset} X_{(\mathcal{G}_L)}|X}$ subject to the constraints

$$D_{\mathcal{K}} \geq \mathbb{E}[d(X, X_{\mathcal{K}})], \quad \mathcal{K} \in \mathcal{G}_L.$$

IV. APPLICATIONS TO SCALABLE CODING

Scalable coding is a special case of the 2-description problem in which the distortion constraint on the second description, i.e., $D_{\{2\}}$, is not imposed. The scalable coding rate-distortion region \mathcal{RD}_{SC} is defined as

$$\mathcal{RD}_{\text{SC}} = \{(R_1, R_2, D_{\{1\}}, D_{\{1,2\}}) : (R_1, R_2, D_{\{1\}}, \infty, D_{\{1,2\}}) \in \mathcal{RD}_{\text{MD}}\}.$$

It is proved in [16] that the quadruple $(R_1, R_2, D_{\{1\}}, D_{\{1,2\}}) \in \mathcal{RD}_{\text{SC}}$ if and only if there exist auxiliary random variables $X_{\{1\}}$ and $X_{\{1,2\}}$ jointly distributed with X such that

$$\begin{aligned} R_1 &\geq I(X; X_{\{1\}}), \\ R_1 + R_2 &\geq I(X; X_{\{1\}}, X_{\{1,2\}}), \\ D_{\{1\}} &\geq \mathbb{E}[d(X, X_{\{1\}})], \\ D_{\{1,2\}} &\geq \mathbb{E}[d(X, X_{\{1,2\}})]. \end{aligned}$$

It is clear that one can obtain \mathcal{RD}_{SC} from $\mathcal{RD}_{\text{EGC}}$ by setting $X_{\{2\}}$ to be a constant.

Since the EGC region is equivalent to the EGC* region, it is not surprising that \mathcal{RD}_{SC} can be written in an alternative form which resembles the EGC* region. By Lemma 1, there exist a random variable $X_{\{2\}}$, jointly distributed with $(X, X_{\{1\}}, X_{\{1,2\}})$, and a function f , such that

- 1) $X_{\{2\}}$ is independent of $X_{\{1\}}$;
- 2) $X_{\{1,2\}} = f(X_{\{1\}}, X_{\{2\}})$;
- 3) $X - (X_{\{1\}}, X_{\{1,2\}}) - X_{\{2\}}$ form a Markov chain.

Therefore, \mathcal{RD}_{SC} can be written as the set of quadruples $(R_1, R_2, D_{\{1\}}, D_{\{1,2\}})$ for which there exist independent random variables $X_{\{1\}}$ and $X_{\{2\}}$, jointly distributed with X , and a function f , such that

$$\begin{aligned} R_1 &\geq I(X; X_{\{1\}}), \\ R_1 + R_2 &\geq I(X; X_{\{1\}}, X_{\{2\}}), \\ D_{\{1\}} &\geq \mathbb{E}[d(X, X_{\{1\}})], \\ D_{\{1,2\}} &\geq \mathbb{E}[d(X, f(X_{\{1\}}, X_{\{2\}}))]. \end{aligned}$$

It is somewhat interesting to note that a direct verification of the fact that this alternative form of \mathcal{RD}_{SC} is equivalent to the EGC* region without constraint $D_{\{2\}}$ is not completely straightforward.

Since $D_{\{2\}}$ is not imposed in scalable coding, the second description essentially plays the role of a refinement layer. It is natural to ask whether the refinement layer itself can be useful, i.e., whether one can use the refinement layer alone to achieve a non-trivial reconstruction distortion. However, without further constraint, this problem is essentially the same as the multiple description problem. Therefore, we shall focus on the following special case. Define the minimum scalably achievable total rate $R(R_1, D_{\{1\}}, D_{\{1,2\}})$ with respect to $(R_1, D_{\{1\}}, D_{\{1,2\}})$ as

$$R(R_1, D_{\{1\}}, D_{\{1,2\}}) = \min\{R_1 + R_2 : (R_1, R_2, D_{\{1\}}, D_{\{1,2\}}) \in \mathcal{RD}_{\text{SC}}\}.$$

It is clear that [16]

$$R(R_1, D_{\{1\}}, D_{\{1,2\}}) = \min_{\substack{I(X; X_{\{1\}}) \leq R_1 \\ \mathbb{E}[d(X, X_{\{1\}})] \leq D_{\{1\}} \\ \mathbb{E}[d(X, X_{\{1,2\}})] \leq D_{\{1,2\}}}} I(X; X_{\{1\}}, X_{\{1,2\}}).$$

Let \mathcal{Q} denote the convex closure of the set of quintuples $(R_1, R_2, D_{\{1\}}, D_{\{2\}}, D_{\{1,2\}})$ for which there exist auxiliary random variables $X_{\mathcal{K}}$, $\emptyset \subset \mathcal{K} \subseteq \{1, 2\}$, jointly distributed with X , such that

$$\begin{aligned} I(X_{\{1\}}; X_{\{2\}}) &= 0, \\ R_k &\geq I(X; X_{\{k\}}), \quad k \in \{1, 2\}, \\ R_1 + R_2 &\geq I(X; X_{\{1\}}, X_{\{2\}}, X_{\{1,2\}}), \\ D_{\mathcal{K}} &\geq \mathbb{E}[d(X, X_{\mathcal{K}})], \quad \emptyset \subset \mathcal{K} \subseteq \{1, 2\}. \end{aligned}$$

Note that \mathcal{Q} is essentially the EGC region with an addition constraint $I(X_{\{1\}}; X_{\{2\}}) = 0$ (i.e., $X_{\{1\}}$ and $X_{\{2\}}$ are independent).

Lemma 3: The EGC region is tight if $R_1 + R_2 = R(R_1, D_{\{1\}}, D_{\{1,2\}})$; more precisely,

$$\begin{aligned} &\{(R_1, R_2, D_{\{1\}}, D_{\{2\}}, D_{\{1,2\}}) \in \mathcal{RD}_{\text{MD}} : R_1 + R_2 = R(R_1, D_{\{1\}}, D_{\{1,2\}})\} \\ &= \{(R_1, R_2, D_{\{1\}}, D_{\{2\}}, D_{\{1,2\}}) \in \mathcal{Q} : R_1 + R_2 = R(R_1, D_{\{1\}}, D_{\{1,2\}})\}. \end{aligned}$$

Proof: It is worth noting that this problem is not identical to multiple description coding without excess rate. Nevertheless, Ahlswede's proof technique [1] (also cf. [20]) can be directly applied here with no essential change. The details are omitted. \blacksquare

Let $R(D)$ denote the rate-distortion function, i.e.,

$$R(D) = \min_{p_{\hat{X}|X}: \mathbb{E}[d(X, \hat{X})] \leq D} I(X; \hat{X}).$$

Now we proceed to study the minimum achievable $D_{\{2\}}$ in the scenario where $R_1 = R(D_{\{1\}})$ and $R_1 + R_2 = R(R(D_{\{1\}}), D_{\{1\}}, D_{\{1,2\}})$. Define

$$D_{\{2\}}^*(D_{\{1\}}, D_{\{1,2\}}) = \min_{\substack{R_1 = R(D_{\{1\}}) \\ R_1 + R_2 = R(R_1, D_{\{1\}}, D_{\{1,2\}}) \\ (R_1, R_2, D_{\{1\}}, D_{\{2\}}, D_{\{1,2\}}) \in \mathcal{RD}_{\text{MD}}}} D_{\{2\}}.$$

Though $D_{\{2\}}^*(D_{\{1\}}, D_{\{1,2\}})$ is in principle computable using Lemma 3, the calculation is often non-trivial due to the convex hull operation in the definition of the EGC region. We shall show that $D_{\{2\}}^*(D_{\{1\}}, D_{\{1,2\}})$ has a more explicit characterization under certain technical conditions.

We need the following definition of weak independence from [2].

Definition 2: For jointly distributed random variables U and V , U is weakly independent of V if the rows of the stochastic matrix $[p_{U|V}(u|v)]$ are linearly dependent.

The following lemma can be found in [2].

Lemma 4: For jointly distributed random variables U and V , there exists a random variable W satisfying

- 1) $U - V - W$ form a Markov chain;

- 2) U and W are independent;
- 3) V and W are not independent;

if and only if U is weakly independent of V .

Theorem 4: If X is not weakly independent of $X_{\{1\}}$ for any $X_{\{1\}}$ induced by $p_{X_{\{1\}}|X}$ that achieves $R(D_{\{1\}})$, then

$$D_{\{2\}}^*(D_{\{1\}}, D_{\{1,2\}}) = \min_{p_{X_{\{1\}}, X_{\{2\}}|X}, g_1, g_2} \mathbb{E}[d(X, g_1(X_{\{2\}}))], \quad (10)$$

where the minimization is over $p_{X_{\{1\}}, X_{\{2\}}|X}$, g_1 , and g_2 subject to the constraints

$$\begin{aligned} I(X_{\{1\}}; X_{\{2\}}) &= 0, \\ I(X; X_{\{1\}}) &= R(D_{\{1\}}), \\ I(X; X_{\{1\}}, X_{\{2\}}) &= R(R(D_{\{1\}}), D_{\{1\}}, D_{\{1,2\}}), \\ \mathbb{E}[d(X, X_{\{1\}})] &\leq D_{\{1\}}, \\ \mathbb{E}[d(X, g_2(X_{\{1\}}, X_{\{2\}}))] &\leq D_{\{1,2\}}. \end{aligned}$$

Here one can assume that $X_{\{2\}}$ is defined on a finite set with cardinality no greater than $|\hat{\mathcal{X}}|^4 - |\hat{\mathcal{X}}|$.

Proof: First we shall show that the right-hand side of (10) is achievable. Given any $D_{\{1\}}$ and $D_{\{1,2\}}$ for which there exist auxiliary random variables $X_{\mathcal{K}}$, $\emptyset \subset \mathcal{K} \subseteq \{1, 2\}$, jointly distributed with X , and a function g_2 such that

$$\begin{aligned} I(X_{\{1\}}; X_{\{2\}}) &= 0, \\ R(D_{\{1\}}) &= I(X; X_{\{1\}}), \\ R(R(D_{\{1\}}), D_{\{1\}}, D_{\{1,2\}}) &= I(X; X_{\{1\}}, X_{\{2\}}), \\ D_{\{1\}} &\geq \mathbb{E}[d(X, X_{\{1\}})], \\ D_{\{1,2\}} &\geq \mathbb{E}[d(X, g_2(X_{\{1\}}, X_{\{2\}}))], \end{aligned}$$

we have

$$\begin{aligned} R(R(D_{\{1\}}), D_{\{1\}}, D_{\{1,2\}}) &= I(X; X_{\{1\}}, X_{\{2\}}) + I(X_{\{1\}}, X_{\{2\}}), \\ R(R(D_{\{1\}}), D_{\{1\}}, D_{\{1,2\}}) - R(D_{\{1\}}) &= I(X_{\{1\}}, X; X_{\{2\}}) \geq I(X; X_{\{2\}}). \end{aligned}$$

Therefore, the quintuple $(R_1, R_2, D_{\{1\}}, D_{\{2\}}, D_{\{1,2\}})$, where

$$\begin{aligned} R_1 &= R(D_{\{1\}}), \\ R_2 &= R(R(D_{\{1\}}), D_{\{1\}}, D_{\{1,2\}}) - R(D_{\{1\}}), \\ D_{\{2\}} &= \mathbb{E}[d(X, g_1(X_{\{2\}}))], \end{aligned}$$

is contained in the EGC* region for any function g_1 . This proves the achievability part.

Now we proceed to prove the converse part. Let $R_1 = R(D_{\{1\}})$ and $R_2 = R(R(D_{\{1\}}), D_{\{1\}}, D_{\{1,2\}}) - R(D_{\{1\}})$. Since the VKG region includes the EGC region, Lemma 3 implies that the VKG region is also tight when the total rate is equal to $R(R(D_{\{1\}}), D_{\{1\}}, D_{\{1,2\}})$. Therefore, if the quintuple $(R_1, R_2, D_{\{1\}}, D_{\{2\}}, D_{\{1,2\}})$ is achievable, then there exist auxiliary random variables $X_{\mathcal{K}}$, $\mathcal{K} \subseteq \{1, 2\}$, jointly distributed with X such that

$$\begin{aligned} R_k &\geq I(X; X_{\emptyset}, X_{\{k\}}), \quad k \in \{1, 2\}, \\ R_1 + R_2 &\geq 2I(X; X_{\emptyset}) + I(X; X_{\{1\}}, X_{\{2\}}, X_{\{1,2\}} | X_{\emptyset}) + I(X_{\{1\}}; X_{\{2\}} | X_{\emptyset}) \\ D_{\mathcal{K}} &\geq \mathbb{E}[d(X, X_{\mathcal{K}})], \quad \emptyset \subset \mathcal{K} \subseteq \{1, 2\}. \end{aligned}$$

By the definition of $R(D_{\{1\}})$ and $R(R(D_{\{1\}}), D_{\{1\}}, D_{\{1,2\}})$, we must have

$$R(D_{\{1\}}) = I(X; X_{\emptyset}, X_{\{1\}}) = I(X; X_{\{1\}}),$$

$$R(R(D_{\{1\}}), D_{\{1\}}, D_{\{1,2\}}) = 2I(X; X_{\emptyset}) + I(X; X_{\{1\}}, X_{\{2\}}, X_{\{1,2\}} | X_{\emptyset}) + I(X_{\{1\}}; X_{\{2\}} | X_{\emptyset}) = I(X; X_{\{1\}}, X_{\{1,2\}}),$$

which implies that

- 1) X and X_{\emptyset} are independent;
- 2) $X - X_{\{1\}} - X_{\emptyset}$ form a Markov chain;
- 3) $X_{\{1\}} - X_{\emptyset} - X_{\{2\}}$ form a Markov chain;
- 4) $X - (X_{\{1\}}, X_{\{1,2\}}) - (X_{\emptyset}, X_{\{2\}})$ form a Markov chain;
- 5) $p_{X_{\{1\}}|X}$ achieves $R(D_{\{1\}})$.

Since X is not weakly independent of $X_{\{1\}}$, it follows from Lemma 4 that X_{\emptyset} and $X_{\{1\}}$ are independent, which further implies that $X_{\{1\}}$ and $X_{\{2\}}$ are independent. By Lemma 1, there exist a random variable Z one \mathcal{Z} with $|\mathcal{Z}| \leq |\hat{\mathcal{X}}|^3 - 1$ and a function f such that

- 1) Z is independent of $(X_{\{1\}}, X_{\{2\}})$;
- 2) $X_{\{1,2\}} = f(X_{\{1\}}, X_{\{2\}}, Z)$;
- 3) $X - (X_{\{1\}}, X_{\{2\}}, X_{\{1,2\}}) - Z$ form a Markov chain.

By setting $X'_{\{2\}} = (X_{\{2\}}, Z)$, it is easy to verify that

$$\begin{aligned} I(X_{\{1\}}; X'_{\{2\}}) &= 0, \\ R(R(D_{\{1\}}), D_{\{1\}}, D_{\{1,2\}}) &= I(X; X_{\{1\}}, X'_{\{1,2\}}), \\ D_{\{2\}} &\geq \mathbb{E}[d(X, g_1(X'_{\{2\}}))], \\ D_{\{1,2\}} &\geq \mathbb{E}[d(X, g_2(X_{\{1\}}, X'_{\{2\}}))], \end{aligned}$$

where $g_1(X'_{\{2\}}) = g_1(X_{\{2\}}, Z) = X_{\{2\}}$ and $g_2(X_{\{1\}}, X'_{\{2\}}) = f(X_{\{1\}}, X_{\{2\}}, Z) = X_{\{1,2\}}$. The proof is complete. ■

Now we give an example for which $D_{\{2\}}^*(D_{\{1\}}, D_{\{1,2\}})$ can be calculated explicitly.

Theorem 5: For a binary symmetric source with Hamming distortion measure,

$$D_{\{2\}}^*(D_{\{1\}}, D_{\{1,2\}}) = \frac{1}{2} + D_{\{1,2\}} - D_{\{1\}}$$

for $0 \leq D_{\{1,2\}} \leq D_{\{1\}} \leq \frac{1}{2}$.

Proof: The proof is given in Appendix VI. ■

V. CONCLUDING REMARKS

We have established a random variable substitution lemma and used it to clarify the relationship among several existing achievable rate-distortion regions for multiple description coding.

Like many other ideas in information theory, our random variable substitution lemma finds its seeds in Shannon's pioneering work. Consider a finite-state channel $p_{Y|XS}$, where the state process $\{S_t\}_{t=1}^{\infty}$ is stationary and memoryless. It is well known that the capacity is given by

$$C = \max_{p_{X|S}} I(X; Y|S)$$

when the state process is available at both the transmitter and the receiver. By Lemma 1, for any (X, Y, S) , there exist a random variable Z on \mathcal{Z} and a function $f : \mathcal{Z} \times \mathcal{S} \rightarrow \mathcal{X}$ such that

- 1) Z is independent of S ;
- 2) $X = f(S, Z)$;
- 3) $Y - (X, S) - Z$ form a Markov chain.

Therefore, we have

$$\begin{aligned} C &= \max_{p_{X|S}} I(X; Y|S) \\ &= \max_{p_Z, f: \mathcal{Z} \times \mathcal{S} \rightarrow \mathcal{X}} I(Z; Y|S). \end{aligned} \quad (11)$$

Note that (11) is in fact Shannon's capacity formula with channel state information at the transmitter [17] applied to the case where the channel state information is also available at the receiver; in this setting, $f(Z, \cdot)$ is sometimes referred to as Shannon's strategy.

APPENDIX I

PROOF OF LEMMA 1

Let Y be a random variable independent of V and uniformly distributed over $[0, 1]$. It is obvious that for each $v \in \mathcal{V}$ we can find a function f_v satisfying

$$\mathbb{P}(f_v(Y) = w) = p_{W|V}(w|v), \quad w \in \mathcal{W}.$$

Now define a function f such that

$$f(v, y) = f_v(y), \quad v \in \mathcal{V}, y \in [0, 1].$$

It is clear that

$$\mathbb{P}(V = v, f(V, Y) = w) = p_{VW}(v, w), \quad v \in \mathcal{V}, w \in \mathcal{W}. \quad (12)$$

Note that

$$\mathbb{P}(V = v, f(V, Y) = w) = \mathbb{E}[\mathbb{P}(V = v, f(V, Y) = w|Y)], \quad v \in \mathcal{V}, w \in \mathcal{W}.$$

It can be shown by invoking the support lemma [4] that there exist a finite set $\mathcal{Z} \subset [0, 1]$ with $|\mathcal{Z}| \leq |\mathcal{V}||\mathcal{W}| - 1$ and a random variable Z on \mathcal{Z} , independent of V , such that

$$\begin{aligned} \mathbb{P}(V = v, f(V, Z) = w) &= \mathbb{E}[\mathbb{P}(V = v, f(V, Z) = w|Z)] \\ &= \mathbb{E}[\mathbb{P}(V = v, f(V, Y) = w|Y)] \\ &= \mathbb{P}(V = v, f(V, Y) = w), \quad v \in \mathcal{V}, w \in \mathcal{W}. \end{aligned} \quad (13)$$

By (12) and (13), we can see that p_{VW} is preserved if W is set to be equal to $f(V, Z)$. Now we incorporate U into the probability space by setting $p_{U|VWZ} = p_{U|VW}$. It can be readily verified that p_{UVW} is preserved and $U - (V, W) - Z$ indeed form a Markov chain. The proof is complete.

APPENDIX II PROOF OF LEMMA 2

By the definition of contra-polymatroid [5], it suffices to show that the set function $\psi : 2^{\mathcal{T}} \rightarrow \mathbb{R}_+$ satisfies 1) $\psi(\emptyset) = 0$ (normalized), 2) $\psi(\mathcal{S}) \leq \psi(\mathcal{T})$ if $\mathcal{S} \subset \mathcal{T}$ (nondecreasing), 3) $\psi(\mathcal{S}) + \psi(\mathcal{T}) \leq \psi(\mathcal{S} \cup \mathcal{T}) + \psi(\mathcal{S} \cap \mathcal{T})$ (supermodular).

1) Normalized: We have

$$\psi(\emptyset) = -I(X; X_\emptyset) - H(X_\emptyset|X) + H(X_\emptyset) = 0.$$

2) Nondecreasing: If $\mathcal{S} \subset \mathcal{T}$, then

$$\begin{aligned} \psi(\mathcal{T}) - \psi(\mathcal{S}) &= (|\mathcal{T}| - |\mathcal{S}|)I(X; X_\emptyset) - H(X_{(2\mathcal{T})}|X) + H(X_{(2\mathcal{S})}|X) + \sum_{\mathcal{A} \in 2^{\mathcal{T}-2\mathcal{S}}} H(X_{\mathcal{A}}|X_{(2^{\mathcal{A}}-\{\mathcal{A}\})}) \\ &\geq -H(X_{(2\mathcal{T}-2\mathcal{S})}|X, X_{(2\mathcal{S})}) + \sum_{\mathcal{A} \in 2^{\mathcal{T}-2\mathcal{S}}} H(X_{\mathcal{A}}|X_{(2^{\mathcal{A}}-\{\mathcal{A}\})}) \\ &\geq -\sum_{k=1}^{|\mathcal{T}|} \sum_{\mathcal{A} \in 2^{\mathcal{T}-2\mathcal{S}}, |\mathcal{A}|=k} H(X_{\mathcal{A}}|X, \{X_{\mathcal{B}}\}_{\mathcal{B} \in 2^{\mathcal{T}}, |\mathcal{B}| < k}) + \sum_{\mathcal{A} \in 2^{\mathcal{T}-2\mathcal{S}}} H(X_{\mathcal{A}}|X_{(2^{\mathcal{A}}-\{\mathcal{A}\})}) \\ &\geq -\sum_{k=1}^{|\mathcal{T}|} \sum_{\mathcal{A} \in 2^{\mathcal{T}-2\mathcal{S}}, |\mathcal{A}|=k} H(X_{\mathcal{A}}|X_{(2^{\mathcal{A}}-\{\mathcal{A}\})}) + \sum_{\mathcal{A} \in 2^{\mathcal{T}-2\mathcal{S}}} H(X_{\mathcal{A}}|X_{(2^{\mathcal{A}}-\{\mathcal{A}\})}) \\ &= 0. \end{aligned}$$

3) Supermodular: We have

$$\begin{aligned}
& (\psi(\mathcal{S} \cup \mathcal{T}) - \psi(\mathcal{T})) - (\psi(\mathcal{S}) - \psi(\mathcal{S} \cap \mathcal{T})) \\
&= (|\mathcal{S} \cup \mathcal{T}| - |\mathcal{T}|)I(X; X_\emptyset) - H(X_{(2^{\mathcal{S} \cup \mathcal{T}} - 2^\mathcal{T})} | X, X_{(2^\mathcal{T})}) + \sum_{\mathcal{A} \in 2^{\mathcal{S} \cup \mathcal{T}} - 2^\mathcal{T}} H(X_{\mathcal{A}} | X_{(2^\mathcal{A} - \{\mathcal{A}\})}) \\
&\quad - (|\mathcal{S}| - |\mathcal{S} \cap \mathcal{T}|)I(X; X_\emptyset) + H(X_{(2^{2^\mathcal{S}} - 2^{\mathcal{S} \cap \mathcal{T}})} | X, X_{(2^{\mathcal{S} \cap \mathcal{T}})}) - \sum_{\mathcal{A} \in 2^{2^\mathcal{S}} - 2^{\mathcal{S} \cap \mathcal{T}}} H(X_{\mathcal{A}} | X_{(2^\mathcal{A} - \{\mathcal{A}\})}) \\
&= -H(X_{(2^{\mathcal{S} \cup \mathcal{T}} - 2^\mathcal{T})} | X, X_{(2^\mathcal{T})}) + H(X_{(2^{2^\mathcal{S}} - 2^{\mathcal{S} \cap \mathcal{T}})} | X, X_{(2^{\mathcal{S} \cap \mathcal{T}})}) + \sum_{\mathcal{A} \in 2^{\mathcal{S} \cup \mathcal{T}} - \mathcal{M}} H(X_{\mathcal{A}} | X_{(2^\mathcal{A} - \{\mathcal{A}\})}) \\
&\geq -H(X_{(2^{\mathcal{S} \cup \mathcal{T}} - \mathcal{M})} | X, X_{(\mathcal{M})}) + \sum_{\mathcal{A} \in 2^{\mathcal{S} \cup \mathcal{T}} - \mathcal{M}} H(X_{\mathcal{A}} | X_{(2^\mathcal{A} - \{\mathcal{A}\})}) \\
&\geq - \sum_{k=1}^{|\mathcal{S} \cup \mathcal{T}|} \sum_{\mathcal{A} \in 2^{\mathcal{S} \cup \mathcal{T}} - \mathcal{M}, |\mathcal{A}|=k} H(X_{\mathcal{A}} | X, \{X_{\mathcal{B}}\}_{\mathcal{B} \in 2^{\mathcal{S} \cup \mathcal{T}}, |\mathcal{B}| < k}) + \sum_{\mathcal{A} \in 2^{\mathcal{S} \cup \mathcal{T}} - \mathcal{M}} H(X_{\mathcal{A}} | X_{(2^\mathcal{A} - \{\mathcal{A}\})}) \\
&\geq - \sum_{k=1}^{|\mathcal{S} \cup \mathcal{T}|} \sum_{\mathcal{A} \in 2^{\mathcal{S} \cup \mathcal{T}} - \mathcal{M}, |\mathcal{A}|=k} H(X_{\mathcal{A}} | X_{(2^\mathcal{A} - \{\mathcal{A}\})}) + \sum_{\mathcal{A} \in 2^{\mathcal{S} \cup \mathcal{T}} - \mathcal{M}} H(X_{\mathcal{A}} | X_{(2^\mathcal{A} - \{\mathcal{A}\})}) \\
&= 0,
\end{aligned}$$

where $\mathcal{M} = 2^\mathcal{S} \cup 2^\mathcal{T}$. The proof is complete.

APPENDIX III

PROOF OF THEOREM 2

It is clear that $\mathcal{RD}_{\text{VKG}^*} \subseteq \mathcal{RD}_{\text{VKG}}$. Therefore, we just need to show that $\mathcal{RD}_{\text{VKG}} \subseteq \mathcal{RD}_{\text{VKG}^*}$.

In view of Lemma 2 and the property of contra-polymatroid [5], for fixed $p_{XX_{(2^{\mathcal{I}_L})}}$ and $\phi_{\mathcal{K}}$, $\emptyset \subset \mathcal{K} \subseteq \mathcal{I}_L$, the region specified by (4) and (5) has $L!$ vertices: $(R_1(\pi), \dots, R_L(\pi), D_{\mathcal{K}}(\pi), \emptyset \subset \mathcal{K} \subseteq \mathcal{I}_L)$ is a vertex for each permutation π on \mathcal{I}_L , where

$$\begin{aligned}
R_{\pi(1)}(\pi) &= \psi(\{\pi(1)\}), \\
R_{\pi(k)}(\pi) &= \psi(\{\pi(1), \dots, \pi(k)\}) - \psi(\{\pi(1), \dots, \pi(k-1)\}), \quad k \in \mathcal{I}_L - \{1\}, \\
D_{\mathcal{K}}(\pi) &= \mathbb{E}[d(X, \phi_{\mathcal{K}}(X_{(2^\mathcal{K})}))], \quad \emptyset \subset \mathcal{K} \subseteq \mathcal{I}_L.
\end{aligned}$$

Since the VKG* region is a convex set, it suffices to show that these $L!$ vertices are contained in the VKG* region.

Without loss of generality, we shall assume that $\pi(k) = k$, $k \in \mathcal{I}_L$. In this case, we have

$$R_L(\pi) = \psi(\mathcal{I}_L) - \psi(\mathcal{I}_{L-1}).$$

Now we proceed to write $R_L(\pi)$ as a sum of certain mutual information quantities. Define

$$\mathcal{S}_1(k) = \{\mathcal{A} : \mathcal{A} \in \mathcal{L}, |\mathcal{A}| = k, L \in \mathcal{A}\}$$

$$\mathcal{S}_2(k) = \{\mathcal{A} : \mathcal{A} \in \mathcal{L}, |\mathcal{A}| < k, L \in \mathcal{A}\}.$$

Note that

$$\begin{aligned}
R_L(\pi) &= I(X; X_\emptyset) + H(X_{(2^{x_{L-1}})}|X) - H(X_{(2^{x_L})}|X) + \sum_{k=1}^L \sum_{\mathcal{A} \in \mathcal{S}_1(k)} H(X_{\mathcal{A}}|X_{(2^{\mathcal{A}-\{\mathcal{A}\}})}) \\
&= I(X; X_\emptyset) - H(X_{(2^{x_L})}|X, X_{(2^{x_{L-1}})}) + H(X_{\{L\}}|X_\emptyset) + \sum_{k=2}^L \sum_{\mathcal{A} \in \mathcal{S}_1(k)} H(X_{\mathcal{A}}|X_{(2^{\mathcal{A}-\{\mathcal{A}\}})}) \\
&= I(X; X_\emptyset) + I(X; X_{\{L\}}|X_{(2^{x_{L-1}})}) + I(X_{(2^{x_{L-1}})}; X_{\{L\}}|X_\emptyset) - H(X_{(2^{\mathcal{L}})}|X, X_{(2^{x_{L-1}})}, X_{\{L\}}) \\
&\quad + \sum_{k=2}^L \sum_{\mathcal{A} \in \mathcal{S}_1(k)} H(X_{\mathcal{A}}|X_{(2^{\mathcal{A}-\{\mathcal{A}\}})}) \\
&= I(X; X_\emptyset) + I(X; X_{\{L\}}|X_{(2^{x_{L-1}})}) + I(X_{(2^{x_{L-1}})}; X_{\{L\}}|X_\emptyset) \\
&\quad + \sum_{k=2}^L \left[\sum_{\mathcal{A} \in \mathcal{S}_1(k)} H(X_{\mathcal{A}}|X_{(2^{\mathcal{A}-\{\mathcal{A}\}})}) - H(X_{(\mathcal{S}_1(k))}|X, X_{(2^{x_{L-1}})}, X_{(\mathcal{S}_2(k))}) \right].
\end{aligned}$$

We arrange the sets in $\mathcal{S}_1(k)$ in some arbitrary order and denote them by $\mathcal{S}_{k,1}, \dots, \mathcal{S}_{k,N(k)}$, respectively, where $N(k) = \binom{L}{k} - \binom{L-1}{k}$. Then for each k ,

$$\begin{aligned}
&\sum_{\mathcal{A} \in \mathcal{S}_1(k)} H(X_{\mathcal{A}}|X_{(2^{\mathcal{A}-\{\mathcal{A}\}})}) - H(X_{(\mathcal{S}_1(k))}|X, X_{(2^{x_{L-1}})}, X_{(\mathcal{S}_2(k))}) \\
&= \sum_{i=1}^{N(k)} \left[H(X_{\mathcal{S}_{k,i}}|X_{(2^{\mathcal{S}_{k,i}-\{\mathcal{S}_{k,i}\}})}) - H(X_{\mathcal{S}_{k,i}}|X, X_{(2^{x_{L-1}})}, X_{(\mathcal{S}_2(k))}, X_{(\{\mathcal{S}_{k,j}\}_{j=1}^{i-1})}) \right] \\
&= \sum_{i=1}^{N(k)} I(X, X_{(2^{x_{L-1}})}, X_{(\mathcal{S}_2(k))}, X_{(\{\mathcal{S}_{k,j}\}_{j=1}^{i-1})}; X_{\mathcal{S}_{k,i}}|X_{(2^{\mathcal{S}_{k,i}-\{\mathcal{S}_{k,i}\}})}) \\
&= \sum_{i=1}^{N(k)} I(X_{(2^{x_{L-1}})}, X_{(\mathcal{S}_2(k))}, X_{(\{\mathcal{S}_{k,j}\}_{j=1}^{i-1})}; X_{\mathcal{S}_{k,i}}|X_{(2^{\mathcal{S}_{k,i}-\{\mathcal{S}_{k,i}\}})}) + \sum_{i=1}^{N(k)} I(X; X_{\mathcal{S}_{k,i}}|X_{(2^{x_{L-1}})}X_{(\mathcal{S}_2(k))}X_{(\{\mathcal{S}_{k,j}\}_{j=1}^{i-1})}) \\
&= \sum_{i=1}^{N(k)} I(X_{(2^{x_{L-1}})}, X_{(\mathcal{S}_2(k))}, X_{(\{\mathcal{S}_{k,j}\}_{j=1}^{i-1})}; X_{\mathcal{S}_{k,i}}|X_{(2^{\mathcal{S}_{k,i}-\{\mathcal{S}_{k,i}\}})}) + I(X; X_{(\mathcal{S}_1(k))}|X_{(2^{x_{L-1}})}X_{(\mathcal{S}_2(k))}).
\end{aligned}$$

Therefore, we have

$$\begin{aligned}
R_L(\pi) &= I(X; X_\emptyset) + I(X; X_{\{L\}}|X_{(2^{x_{L-1}})}) + I(X_{(2^{x_{L-1}})}; X_{\{L\}}|X_\emptyset) \\
&\quad + \sum_{k=2}^L \left[\sum_{i=1}^{N(k)} I(X_{\mathcal{S}_{k,i}}; X_{(\{\mathcal{S}_{k,j}\}_{j=1}^{i-1})}X_{(2^{x_{L-1}})}X_{(\mathcal{S}_2(k))}|X_{(2^{\mathcal{S}_{k,i}-\{\mathcal{S}_{k,i}\}})}) + I(X; X_{(\mathcal{S}_1(k))}|X_{(2^{x_{L-1}})}X_{(\mathcal{S}_2(k))}) \right] \\
&= I(X; X_\emptyset) + I(X; X_{(\mathcal{S}_2(L))}, X_{\mathcal{L}}|X_{(2^{x_{L-1}})}) + I(X_{(2^{x_{L-1}})}; X_{\{L\}}|X_\emptyset) \\
&\quad + \sum_{k=2}^{L-1} \left[\sum_{i=1}^{N(k)} I(X_{(2^{x_{L-1}})}, X_{(\mathcal{S}_2(k))}, X_{(\{\mathcal{S}_{k,j}\}_{j=1}^{i-1})}; X_{\mathcal{S}_{k,i}}|X_{(2^{\mathcal{S}_{k,i}-\{\mathcal{S}_{k,i}\}})}) \right]. \tag{14}
\end{aligned}$$

It follows from Lemma 1 that there exist an auxiliary random variables Z and a function f such that

- 1) Z is independent of $(X_{(2^{x_{L-1}})}, X_{(\mathcal{S}_2(L))})$;
- 2) $X_{\mathcal{L}} = f(X_{(2^{x_{L-1}})}, X_{(\mathcal{S}_2(L))}, Z)$;

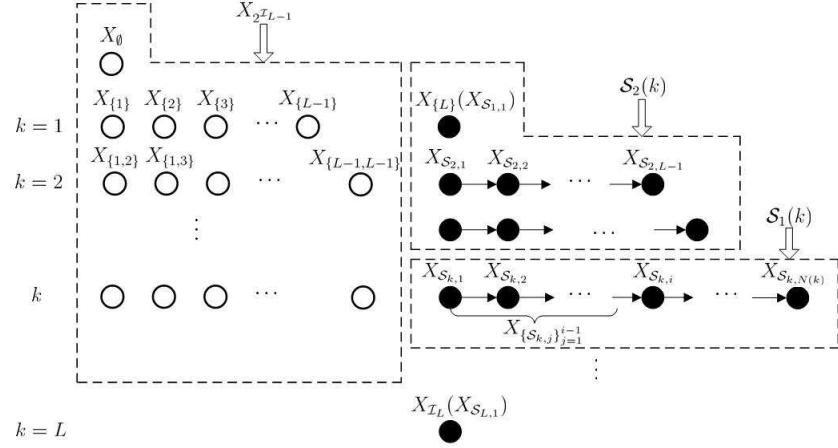

Fig. 2. The Structure of auxiliary random variables for the VKG region.

3) $X - (X_{(2^{x_{L-1}})}, X_{(S_2(L))}, X_{\mathcal{I}_L}) - Z$ form a Markov chain.

Therefore, we have

$$I(X; X_{(S_2(L))}, X_{\mathcal{I}_L} | X_{(2^{x_{L-1}})}) = I(X; X_{(S_2(L))}, Z | X_{(2^{x_{L-1}})}),$$

$$I(X_{(2^{x_{L-1}})}; X_{\{L\}} | X_{\emptyset}) = I(X_{(2^{x_{L-1}})}; X_{\{L\}}, Z | X_{\emptyset}),$$

and

$$\begin{aligned} & I(X_{(2^{x_{L-1}})}, X_{(S_2(k))}, X_{(\{S_{k,j}\}_{j=1}^{i-1})}; X_{S_{k,i}} | X_{(2^{S_{k,i}-\{S_{k,i}\}})}) \\ &= I(X_{(2^{x_{L-1}})}, X_{(S_2(k))}, X_{(\{S_{k,j}\}_{j=1}^{i-1})}, Z; X_{S_{k,i}} | X_{(2^{S_{k,i}-\{S_{k,i}\}})}) \end{aligned}$$

for $1 \leq i \leq N(k)$ and $2 \leq k \leq L-1$. Now it can be easily verified that $(R_1(\pi), \dots, R_L(\pi), D_{\mathcal{K}}(\pi), \emptyset \subset \mathcal{K} \subseteq \mathcal{I}_L)$ is preserved if we substitute $X_{\{L\}}$ with $(X_{\{L\}}, Z)$, set $X_{\mathcal{I}_L}$ to be a constant, and modify $\phi_{\mathcal{K}}, \emptyset \subset \mathcal{K} \subseteq \mathcal{I}_L$, accordingly. By the definition of the VKG* region, it is clear that $(R_1(\pi), \dots, R_L(\pi), D_{\mathcal{K}}(\pi), \emptyset \subset \mathcal{K} \subseteq \mathcal{I}_L) \in \mathcal{RD}_{\text{VKG}^*}$. The proof is complete.

APPENDIX IV

PROOF OF THEOREM 3

Let $R_1^* = \psi(\{1\})$, and $R_k^* = \psi(\mathcal{I}_k) - \psi(\mathcal{I}_{k-1})$, $k \in \mathcal{I}_L - \{1\}$. By Lemma 2 and the property of contra-polymatroid [5], (R_1^*, \dots, R_L^*) is a vertex of the rate region $\{(R_1, \dots, R_L) : R_{\mathcal{K}} \geq \psi(\mathcal{K}), \emptyset \subset \mathcal{K} \subseteq \mathcal{I}_L\}$; moreover, we have

$$\begin{aligned} & \min_{(R_1, \dots, R_L) \in \mathcal{R}_{\text{IH-VKG}}(D_{\mathcal{K}}, \mathcal{K} \in \mathcal{H}_L)} \sum_{k=1}^L \alpha_k R_k \\ &= \min_{p_{X_{\emptyset}, X_{\{1\}} \dots X_{\{L\}} | X, \phi_{\mathcal{K}}, \mathcal{K} \in \mathcal{H}_L}} \sum_{k=1}^L \alpha_k R_k^*, \end{aligned} \tag{15}$$

where the minimization in (15) is over $p_{X_\emptyset X_{\{1\}} \dots X_{\{L\}}|X}$, and $\phi_{\mathcal{K}}, \mathcal{K} \in \mathcal{H}_L$, subject to the constraints

$$D_{\mathcal{K}} \geq \mathbb{E}[d(X, \phi_{\mathcal{K}}(X_{(2^{\mathcal{K}})}))], \quad \mathcal{K} \in \mathcal{H}_L.$$

It follows from Theorem 2 that $X_{\mathcal{I}_L}$ can be eliminated. Inspecting (14) reveals that the same method can be used to eliminate $X_{\mathcal{K}}, \mathcal{K} \in \mathcal{S}_2(L) - \{L\}$, successively in the reverse order (i.e., the bottom-to-top and right-to-left order in Fig.2). For k from $L-1$ to 2, we write R_k^* in a form analogous to (14) and execute this elimination procedure. In this way all the auxiliary random variables, except $X_\emptyset, X_{\{1\}}, \dots, X_{\{L\}}$, are eliminated. It can be verified that the resulting expression for (R_1^*, \dots, R_L^*) is

$$R_k^* = I(X; X_\emptyset) + I(X, \{X_{\{i\}}\}_{i=1}^{k-1}; X_{\{k\}}|X_\emptyset), \quad k \in \mathcal{I}_L.$$

The proof is complete.

APPENDIX V PROOF OF COROLLARY 3

First we shall show that (6) is greater than or equal to (7). Let $X'_{\{k\}} = \phi_{\{k\}}(X_\emptyset, X_{\{k\}})$, $k \in \mathcal{I}_L$, and $X'_{\mathcal{I}_k} = \phi_{\mathcal{I}_k}(X_\emptyset, X_{\{1\}}, \dots, X_{\{k\}})$, $k \in \mathcal{I}_L - \{1\}$. It can be verified that

$$\begin{aligned} & \sum_{k=1}^L \alpha_k [I(X; X_\emptyset) + I(X, \{X_{\{i\}}\}_{i=1}^{k-1}; X_{\{k\}}|X_\emptyset)] \\ &= \sum_{k=1}^L \alpha_k [I(X; X_\emptyset) + I(\{X_{\{i\}}\}_{i=1}^{k-1}; X_{\{k\}}|X_\emptyset) + I(X; X_{\{k\}}|X_\emptyset, \{X_{\{i\}}\}_{i=1}^{k-1})] \\ &= \sum_{k=2}^L \alpha_k [I(X; X_\emptyset) + I(\{X_{\{i\}}\}_{i=1}^{k-1}; X_{\{k\}}|X_\emptyset)] + \sum_{k=1}^L (\alpha_k - \alpha_{k+1}) I(X; X_\emptyset, \{X_{\{i\}}\}_{i=1}^k) \\ &\geq \sum_{k=2}^L \alpha_k [I(X; X_\emptyset) + I(X'_{(\mathcal{H}_{k-1})}; X'_{\{k\}}|X_\emptyset)] + \sum_{k=1}^L (\alpha_k - \alpha_{k+1}) I(X; X_\emptyset, X'_{(\mathcal{H}_k)}) \\ &= \sum_{k=1}^L \alpha_k [I(X; X_\emptyset) + I(X'_{(\mathcal{H}_{k-1})}; X'_{\{k\}}|X_\emptyset) - I(X; X_\emptyset, X'_{(\mathcal{H}_{k-1})}) + I(X; X_\emptyset, X'_{(\mathcal{H}_k)})] \\ &= \sum_{k=1}^L \alpha_k [I(X; X_\emptyset) + I(X'_{(\mathcal{H}_{k-1})}; X'_{\{k\}}|X_\emptyset) + I(X; X'_{\{k\}}, X'_{\mathcal{I}_k}|X_\emptyset, X'_{(\mathcal{H}_{k-1})})], \end{aligned}$$

where $\alpha_{L+1} \triangleq 0$.

Now we proceed to show that (7) is greater than or equal to (6). It follows from Lemma 1 that there exist a random variable Z and a function f such that

- 1) Z is independent of $(X_\emptyset, X_{(\mathcal{H}_{L-1})}, X_{\{L\}})$;
- 2) $X_{\mathcal{I}_L} = f(X_\emptyset, X_{(\mathcal{H}_{L-1})}, X_{\{L\}}, Z)$;
- 3) $X - (X_\emptyset, X_{(\mathcal{H}_L)}) - Z$ form a Markov chain.

Note that

$$I(X_{(\mathcal{H}_{L-1})}; X_{\{L\}} | X_{\emptyset}) = I(X_{(\mathcal{H}_{L-1})}; X_{\{L\}}, Z | X_{\emptyset}),$$

$$I(X; X_{\{L\}}, X_{\mathcal{I}_L} | X_{\emptyset}, X_{(\mathcal{H}_{L-1})}) = I(X; X_{\{L\}}, Z | X_{\emptyset}, X_{(\mathcal{H}_{L-1})}).$$

Therefore, we can substitute $X_{\{L\}}$ with $(X_{\{L\}}, Z)$ and eliminate $X_{\mathcal{I}_L}$. It is clear that one can successively eliminate $X_{\mathcal{I}_{L-1}}, \dots, X_{\mathcal{I}_2}$ in a similar manner. The proof is complete.

APPENDIX VI

PROOF OF THEOREM 5

It is obvious that $D_{\{2\}}^*(D_{\{1\}}, D_{\{1,2\}}) = D_{\{1,2\}}$ if $D_{\{1\}} = \frac{1}{2}$. Therefore, we shall only consider the case $D_{\{1\}} < \frac{1}{2}$.

Since binary symmetric sources are successively refinable, it follows that

$$R(D_{\{1\}}) = 1 - H_b(D_{\{1\}}),$$

$$R(R_1(D_{\{1\}}), D_{\{1\}}, D_{\{1,2\}}) = 1 - H_b(D_{\{1,2\}}),$$

where $H_b(\cdot)$ is the binary entropy function. If $D_{\{1\}} < \frac{1}{2}$, then $R(D_{\{1\}})$ is achieved if and only if $p_{X_{\{1\}}|X}$ is a binary symmetric channel with crossover probability $D_{\{1\}}$; it is clear that X is not weakly independent with the resulting $X_{\{1\}}$. Therefore, Theorem 4 is applicable here.

Define $X_{\{1,2\}} = g_2(X_{\{1\}}, X_{\{2\}})$. Note that we must have $\mathbb{E}[d(X, X_{\{1,2\}})] \leq D_{\{1,2\}}$ and

$$I(X; X_{\{1\}}, X_{\{2\}}) = I(X; X_{\{1\}}, X_{\{2\}}, X_{\{1,2\}})$$

$$= I(X; X_{\{1,2\}})$$

$$= 1 - H_b(D_{\{1,2\}}),$$

which implies that $X - X_{\{1,2\}} - (X_{\{1\}}, X_{\{2\}})$ form a Markov chain and $p_{X_{\{1,2\}}|X}$ is a binary symmetric channel with crossover probability $D_{\{1,2\}}$. Therefore, $p_{X_{\{1\}}X_{\{2\}}|X_{\{1,2\}}}$ is completely specified by the backward test channels shown in Fig. 3. Now it is clear that one can obtain $D^*(D_{\{1\}}, D_{\{1,2\}})$ by solving the following optimization problem

$$D^*(D_{\{1\}}, D_{\{1,2\}}) = \min_{p_{X_{\{2\}}|X_{\{1\}}X_{\{1,2\}}}, g_1} \mathbb{E}[d(X, g_1(X_{\{2\}}))]$$

subject to the constraints

- 1) $X_{\{1\}}$ and $X_{\{2\}}$ are independent;
- 2) $X_{\{1,2\}}$ is a deterministic function of $X_{\{1\}}$ and $X_{\{2\}}$;
- 3) $X - X_{\{1,2\}} - (X_{\{1\}}, X_{\{2\}})$ form a Markov chain.

Assume that $X_{\{2\}}$ takes values in $\{0, 1, \dots, n-1\}$ for some finite n . We tabulate $p_{X_{\{1\}}X_{\{2\}}|X_{\{1,2\}}}$, $p_{X_{\{1\}}X_{\{2\}}}$, and $p_{X_{\{1\}}X_{\{2\}}|X_{\{1,2\}}}$ for ease of reading.

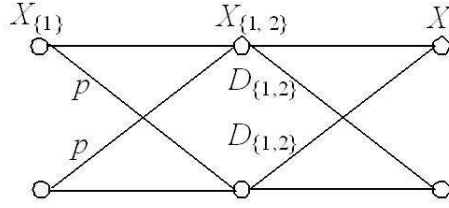

Fig. 3. The backward channels for successive refinement of a binary symmetric source: $p = \frac{D_{\{1\}} - D_{\{1,2\}}}{1 - 2D_{\{1,2\}}}$.

$x, x_{\{1\}}, x_{\{1,2\}}$	$x_{\{2\}} = 0$	$x_{\{2\}} = 1$	$x_{\{2\}} = 2$	\dots	$x_{\{2\}} = n-1$
0,0,0	$a_{0,0}$	$a_{0,1}$	$a_{0,2}$	\dots	$a_{0,n-1}$
0,0,1	$a_{1,0}$	$a_{1,1}$	$a_{1,2}$	\dots	$a_{1,n-1}$
0,1,0	$a_{2,0}$	$a_{2,1}$	$a_{2,2}$	\dots	$a_{2,n-1}$
\vdots	\vdots	\vdots	\vdots	\ddots	\vdots
1,1,1	$a_{7,0}$	$a_{7,1}$	$a_{7,2}$	\dots	$a_{7,n-1}$

$x_{\{1\}}$	$x_{\{2\}} = 0$	\dots	$x_{\{2\}} = n-1$
0	$a_{0,0} + a_{1,0} + a_{4,0} + a_{5,0}$	\dots	$a_{0,n-1} + a_{1,n-1} + a_{4,n-1} + a_{5,n-1}$
1	$a_{2,0} + a_{3,0} + a_{6,0} + a_{7,0}$	\dots	$a_{2,n-1} + a_{3,n-1} + a_{6,n-1} + a_{7,n-1}$

x	$x_{\{2\}} = 0$	\dots	$x_{\{2\}} = n-1$
0	$a_{0,0} + a_{1,0} + a_{2,0} + a_{3,0}$	\dots	$a_{0,n-1} + a_{1,n-1} + a_{2,n-1} + a_{3,n-1}$
1	$a_{4,0} + a_{5,0} + a_{6,0} + a_{7,0}$	\dots	$a_{4,n-1} + a_{5,n-1} + a_{6,n-1} + a_{7,n-1}$

$x_{\{1,2\}}$	$x_{\{1\}}, x_{\{2\}} = 0,0$	\dots	$0, n-1$	$1,0$	\dots	$1, n-1$
0	$a_{0,0} + a_{4,0}$	\dots	$a_{0,n-1} + a_{4,n-1}$	$a_{2,0} + a_{6,0}$	\dots	$a_{2,n-1} + a_{6,n-1}$
1	$a_{1,0} + a_{5,0}$	\dots	$a_{1,n-1} + a_{5,n-1}$	$a_{3,0} + a_{7,0}$	\dots	$a_{3,n-1} + a_{7,n-1}$

According to $p_{X X_{\{1\}} X_{\{1,2\}}}$ (cf. Fig. 3), it is easy to see that

$$\sum_{i=0}^{n-1} a_{0,i} = \sum_{i=0}^{n-1} a_{7,i} = \frac{1}{2}(1-p)(1-D_{\{1,2\}}),$$

$$\sum_{i=0}^{n-1} a_{1,i} = \sum_{i=0}^{n-1} a_{6,i} = \frac{1}{2}pD_{\{1,2\}},$$

$$\begin{aligned}
\sum_{i=0}^{n-1} a_{2,i} &= \sum_{i=0}^{n-1} a_{5,i} = \frac{1}{2}p(1 - D_{\{1,2\}}), \\
\sum_{i=0}^{n-1} a_{3,i} &= \sum_{i=0}^{n-1} a_{4,i} = \frac{1}{2}(1-p)D_{\{1,2\}}.
\end{aligned} \tag{16}$$

Furthermore, one can verify the following statements.

1) The fact that $X_{\{1\}}$ and $X_{\{2\}}$ are independent and that $X_{\{1\}}$ is uniformly distributed over $\{0, 1\}$ implies

$$a_{0,i} + a_{1,i} + a_{4,i} + a_{5,i} = a_{2,i} + a_{3,i} + a_{6,i} + a_{7,i}, \quad i = 0, \dots, n-1. \tag{17}$$

2) The fact that $X_{\{1,2\}}$ is a deterministic function of $(X_{\{1\}}, X_{\{2\}})$ implies

$$(a_{0,i} + a_{4,i})(a_{1,i} + a_{5,i}) = (a_{2,i} + a_{6,i})(a_{3,i} + a_{7,i}) = 0, \quad i = 0, \dots, n-1. \tag{18}$$

3) The fact that $X - X_{\{1,2\}} - (X_{\{1\}}, X_{\{2\}})$ form a Markov chain implies

$$\begin{aligned}
a_{0,i} &= \frac{1 - D_{\{1,2\}}}{D_{\{1,2\}}} a_{4,i}, & a_{5,i} &= \frac{1 - D_{\{1,2\}}}{D_{\{1,2\}}} a_{1,i} \\
a_{2,i} &= \frac{1 - D_{\{1,2\}}}{D_{\{1,2\}}} a_{6,i}, & a_{7,i} &= \frac{1 - D_{\{1,2\}}}{D_{\{1,2\}}} a_{3,i}, \quad i = 0, \dots, n-1.
\end{aligned} \tag{19}$$

According to (18), there are four possibilities for each i :

$$\begin{aligned}
&a_{0,i} = a_{2,i} = a_{4,i} = a_{6,i} = 0, \\
\text{or} & \quad a_{0,i} = a_{3,i} = a_{4,i} = a_{7,i} = 0, \\
\text{or} & \quad a_{1,i} = a_{2,i} = a_{5,i} = a_{6,i} = 0, \\
\text{or} & \quad a_{1,i} = a_{3,i} = a_{5,i} = a_{7,i} = 0, \quad i = 0, \dots, n-1.
\end{aligned}$$

Moreover, in view of (17), we can partition $\{0, 1, \dots, n-1\}$ into four disjoint sets \mathcal{S}_j , $j = 1, 2, 3, 4$, such that

$$\begin{aligned}
&a_{1,i} + a_{5,i} = a_{3,i} + a_{7,i}, \quad i \in \mathcal{S}_1 \\
&a_{1,i} + a_{5,i} = a_{2,i} + a_{6,i}, \quad i \in \mathcal{S}_2 \\
&a_{0,i} + a_{4,i} = a_{3,i} + a_{7,i}, \quad i \in \mathcal{S}_3 \\
&a_{0,i} + a_{4,i} = a_{2,i} + a_{6,i}, \quad i \in \mathcal{S}_4.
\end{aligned} \tag{20}$$

Combining (19) and (20) yields

$$\begin{aligned}
&a_{1,i} = a_{3,i}, \quad a_{5,i} = a_{7,i}, \quad i \in \mathcal{S}_1 \\
&a_{1,i} = a_{6,i}, \quad a_{2,i} = a_{5,i}, \quad i \in \mathcal{S}_2 \\
&a_{0,i} = a_{7,i}, \quad a_{3,i} = a_{4,i}, \quad i \in \mathcal{S}_3 \\
&a_{0,i} = a_{2,i}, \quad a_{4,i} = a_{6,i}, \quad i \in \mathcal{S}_4.
\end{aligned}$$

It is easy to see that different values in each \mathcal{S}_j , $j = 1, 2, 3, 4$, can be combined. That is to say, we can assume that $X_{\{2\}}$ takes values in $\{0, 1, 2, 3\}$ with no loss of generality. As a consequence, $p_{XX_{\{1\}}X_{\{2\}}X_{\{1,2\}}}$ and $p_{XX_{\{2\}}}$ can be re-tabulated as follows.

$x, x_{\{1\}}, x_{\{1,2\}}$ \diagdown $x_{\{2\}}$	0	1	2	3
0,0,0	0	0	β_3	β_4
0,0,1	α_1	α_2	0	0
0,1,0	0	β_2	0	β_4
0,1,1	α_1	0	α_3	0
1,0,0	0	0	α_3	α_4
1,0,1	β_1	β_2	0	0
1,1,0	0	α_2	0	α_4
1,1,1	β_1	0	β_3	0

x \diagdown $x_{\{2\}}$	0	1	2	3
0	$2\alpha_1$	$\alpha_2 + \beta_2$	$\alpha_3 + \beta_3$	$2\beta_4$
1	$2\beta_1$	$\alpha_2 + \beta_2$	$\alpha_3 + \beta_3$	$2\alpha_4$

Note that α_i and β_i satisfy

$$\beta_i = \frac{1 - D_{\{1,2\}}}{D_{\{1,2\}}} \alpha_i, \quad i = 1, 2, 3, 4,$$

$$\alpha_1 + \alpha_2 = \alpha_4 + \alpha_2 = \frac{1}{2} p D_{\{1,2\}},$$

$$\alpha_1 + \alpha_3 = \frac{1}{2} (1 - p) D_{\{1,2\}},$$

where the first four equalities follow (19) while the others follow (16). Using $X_{\{2\}}$ to reconstruct X , one can achieve

$$\begin{aligned} D_{\{2\}} &= 2\alpha_1 + \alpha_2 + \beta_2 + \alpha_3 + \beta_3 + 2\alpha_4 \\ &= \frac{1}{2} - (\beta_1 - \alpha_1 + \beta_4 - \alpha_4) \\ &= \frac{1}{2} - \frac{1 - 2D_{\{1,2\}}}{D_{\{1,2\}}} \alpha_1 - \frac{1 - 2D_{\{1,2\}}}{D_{\{1,2\}}} \alpha_4. \end{aligned}$$

It can be easily verified that $D_{\{2\}}$ is minimized when $\alpha_1 = \alpha_4 = \frac{1}{2} p D_{\{1,2\}}$. Therefore, we have

$$\begin{aligned} D_{\{2\}}^*(D_{\{1\}}, D_{\{1,2\}}) &= 2pD_{\{1,2\}} + \frac{1}{2}(1 - 2p) \\ &= \frac{1}{2} + D_{\{1,2\}} - D_{\{1\}}. \end{aligned}$$

REFERENCES

- [1] R. Ahlswede, "The rate-distortion region for multiple descriptions without excess rate," *IEEE Trans. Inf. Theory*, vol. 31, pp. 721-726, Nov. 1985.
- [2] T. Berger, and R. Yeung, "Multiterminal source encoding with encoder breakdown," *IEEE Trans. Inf. Theory*, vol. 35, pp. 237-244, Mar. 1989.

- [3] J. Chen, "Rate region of Gaussian multiple description coding with individual and central distortion constraints," *IEEE Trans. Inf. Theory*, vol. 55, pp. 3991-4005, Sep. 2009.
- [4] I. Csiszar and J. Korner, *Information Theory: Coding Theorems for Discrete Memoryless Systems*. Budapest, Hungary, AKADEMIAI KIADO, 1981.
- [5] J. Edmonds, "Submodular functions, matroids and certain polyhedra," in *Combinatorial Structures and Their Applications*, R. Guy, H. Hanani, N. Sauer, and J. Schonheim, Eds. New York: Gordon and Breach, 1970, pp. 6987.
- [6] W. H. R. Equitz and T. M. Cover, "Successive refinement of information," *IEEE Trans. Inf. Theory*, vol. 37, pp. 269-275, Mar. 1991.
- [7] A. El Gamal and T. Cover, "Achievable rates for multiple descriptions," *IEEE Trans. Inf. Theory*, vol. 28, pp. 851-857, Nov. 1982.
- [8] H. Feng and M. Effros, "On the rate loss of multiple description source codes," *IEEE Trans. Inf. Theory*, vol. 51, pp. 671-683, Feb. 2005.
- [9] F. Fu and R. W. Yeung, "On the rate-distortion region for multiple descriptions," *IEEE Trans. Inf. Theory*, vol. 48, pp. 2012-2021, July 2002.
- [10] V. Koshlev, "Hierarchical coding of discrete sources," *Probl. Pered. Inform.*, vol. 16, no. 3, pp. 31-49, 1980.
- [11] —, "An evaluation of the average distortion for discrete schemes of sequential approximation," *Probl. Pered. Inform.*, vol. 17, no. 3, pp. 20-33, 1981.
- [12] L. Lastras-Montano and V. Castelli, "Near sufficiency of random coding for two descriptions," *IEEE Trans. Inf. Theory*, vol. 52, pp. 681-695, Feb. 2006.
- [13] L. Ozarow, "On a source-coding problem with two channels and three receivers," *Bell Syst. Tech. J.*, vol. 59, no. 10, pp. 1909-1921, Dec. 1980.
- [14] S. S. Pradhan, R. Puri, and K. Ramchandran, " n -channel symmetric multiple descriptions-part I: (n, k) source-channel erasure codes," *IEEE Trans. Inf. Theory*, vol. 50, pp. 47-61, Jan. 2004.
- [15] R. Puri, S. S. Pradhan, and K. Ramchandran, " n -channel symmetric multiple descriptions-part II: an achievable rate-distortion region," *IEEE Trans. Inf. Theory*, vol. 51, pp. 1377-1392, Apr. 2005.
- [16] B. Rimoldi, "Successive refinement of information: characterization of the achievable rates," *IEEE Trans. Inf. Theory*, vol. 40, pp. 253-259, Jan. 1994.
- [17] C. Shannon, "Channels with side information at the transmitter," *IBM J. Res. Devel.*, vol. 2, pp. 289-293, 1958.
- [18] C. Tian and J. Chen, "New coding schemes for the symmetric K -description problem," *IEEE Trans. Inf. Theory*, submitted for publication.
- [19] C. Tian, S. Mohajer, and S. Diggavi, "Approximating the Gaussian multiple description rate region under symmetric distortion constraints," *IEEE Trans. Inf. Theory*, vol. 55, pp. 3869-3891, Aug. 2009.
- [20] E. Tuncel and K. Rose, "Additive successive refinement," *IEEE Trans. Inf. Theory*, vol. 49, pp. 1983-1991, Aug. 2003.
- [21] R. Venkataramani, G. Kramer, and V. K. Goyal, "Multiple description coding with many channels," *IEEE Trans. Inf. Theory*, vol. 49, pp. 2106-2114, Sept. 2003.
- [22] H. Wang and P. Viswanath, "Vector Gaussian multiple description with individual and central receivers," *IEEE Trans. Inf. Theory*, vol. 53, pp. 2133-2153, Jun. 2007.
- [23] Z. Zhang, and T. Berger, "New results in binary multiple descriptions," *IEEE Trans. Inf. Theory*, vol. 33, pp. 50-521, July 1987.
- [24] R. Zamir, "Gaussian codes and Shannon bounds for multiple descriptions," *IEEE Trans. Inf. Theory*, vol. 45, pp. 2629-2636, Nov. 1999.