

Experimental Study of Application Specific Source Coding for Wireless Sensor Networks

Muthiah Annamalai
muthiah.annamalai@uta.edu

Darshan Shrestha
darshan.shrestha@uta.edu

Saibun Tjuatja,
tjuatja@uta.edu

Department of Electrical Engineering,
University of Texas at Arlington, USA.

Abstract—The energy bottleneck in Wireless Sensor Network(WSN) can be reduced by limiting communication overhead. Application specific source coding schemes for the sensor networks provide fewer bits to represent the same amount of information exploiting the redundancy present in the source model, network architecture and the physical process. This paper reports the performance of representative codes from various families of source coding schemes (lossless, lossy, constant bit-rate, variable bit-rate, distributed and joint encoding/decoding) in terms of energy consumed, bit-rate achieved, quantization-error/reconstruction-error, latency and complexity of encoder-decoder(codec). A reusable frame work for testing source codes is provided. Finally we propose a set of possible applications and suitable source codes in terms of these parameters. ^{1 2}

I. INTRODUCTION

WSNs exhibit new approaches to providing reliable, time-critical and constant environment sensing, event detecting and reporting, target localization, and tracking. Since the power supply cannot be replenished in most cases, energy efficient techniques and protocols are needed to extend the lifetime of the system.

Generally cost of transmission is higher than the cost of processing [20]. Communicating the data after source coding [19], can save energy by reducing the number of bits transmitted over radio. Similarly, channel coding can provide a better Bit Error Rate(BER) than achieved at the uncoded power level. This coding gain represents energy savings. Local processing is useful as long as it leads to energy savings compared to uncoded transmission [20].

In this paper, source coding techniques that exploit statistical redundancy in sensor data and correlations in space and time were used. In dense sensor networks, observed functions of physical environments change slowly over small distances. This sensor data are correlated in space. Moreover these physical processes do not change abruptly in time, so the readings are correlated in time as well. This redundancy due to temporal and spatial correlation can be exploited. Such correlation structures allow sophisticated compression and distributed

source coding schemes from Information Theory(eg. DISCUS) [5], Signal Processing(eg. Haar Wavelet) [4] to be used.

Source coding techniques for correlated data seek to translate the theoretical coding-rate of Slepian-Wolf limits [3] to practical codes. Recently the DISCUS approach has generated new techniques to construct source codes to reach this limit. The other idea in correlated data compression comes from signal processing, which is the Haar wavelet [4].

Sensor networks are application specific by design. So various protocols and architecture used have to be customized for each network. For example, a sensor network deployed in the hilly mountains for environmental monitoring do not have stringent requirement on event detection compared to sensor network deployed for intruder detection. Dropped packets and inaccuracy may not be detrimental in the case of environmental monitoring but same amount of low-accuracy and high-delay might defeat the purpose of a intruder detection network. Therefore, it is up to an application to somehow define the degree of accuracy of the results required. Source coding models depend largely on the tolerance of each network towards approximated results (lossless,lossy), latency of coder-decoder and energy consumed. This requires source codes which are application specific. The contributions of the paper are heuristic mapping of source codes with possible applications, and a reusable frame work for testing source codes in WSNs. The following sections discuss coding schemes, experimental setup, implementation details and results.

II. SOURCE CODES

The characteristics of various source codes are reviewed. The source codes can be broadly classified according to Table 1.

TABLE I
SOURCE CODE CLASSIFICATION

Parameter	Code	
Loss	lossless	lossy
	T-code,Fibonacci	DISCUS,[A& μ]-law, Modulo-code
Joint	coding & decoding	decoding
	Haar,Modulo-code	DISCUS
Bit rate	Variable	Constant
	Fibonacci, T-Code	μ -law, A-law, DISCUS

¹ This work was done at Wave Scattering Research Center during April-May 2006.

²The source code for the TinyOS implementation of various codecs can be obtained freely upon request to the primary author.

A. A-law compander

A compander is a pair of compressor and expander functions which perform in tandem, generally in lossy coding. The A-law compander is a non-uniform quantization function which resolves linearly upto certain significant values and quantizes the remaining values non-linearly. A-law compressor and expander together form a lossy compression system that is used to compress the samples of the signals [17]. The standard European and widely accepted compander is A-law. In this implementation integer-quantized A-law scaled to range 0-255 was implemented. A=87.6 was used.

B. μ -law compander

The μ -law compander was also used in a similar scaled and integer-quantized manner like the A-law. μ -law is the accepted standard in the North America & Japan [17]. $\mu=255$ was used.

C. Differential Pulse Code Modulation (DPCM)

DPCM sends first sample in a frame uncoded, while the rest of the samples are coded as difference from the previous sample and transmitted. At the decoding side, the first sample is taken as such and successive samples are added to the previously decoded value to generate the decoded samples.

D. Fibonacci code

It is a form of universal code employed in data compression with useful property that all codes end with 11, and no code ends with 10. This implies that even if there are errors in the stream, it is possible to resynchronize with the data.

Fibonacci code is essentially a number system based on the weights of the Fibonacci series. Any number is decomposed as the sum of the weights of Fibonacci numbers. For example, the value 10 is encoded into Fibonacci number as $(010011)_2$, which is interpreted as $10 = 2.1 + 8.1$ due to position of 1 being at the weights 2, 8.

Construction of Fibonacci code can be found in [9]. The variable length code so obtained, can be used to map to symbols based on their probabilities to reduce the average code word length $L_{avg} = \sum_{i=1}^N l_i p_i$, where p_i is probability of i^{th} symbol and l_i its code-length in bits, for a N symbol source.

E. T-code

T-code [13] is a variant of Huffman code built iteratively from the case of a simple extension of Huffman code. Once the code size reaches the desired amount of symbols, the most frequent symbols are assigned code words with the least length such that the average code word length (L_{avg}) is minimized. For example, T-codes are built from the set $S(0) = \{1, 00, 01\}$, for level-1. For the next level the any one symbol is prefixed to the rest of the symbols, to obtain $S(0, 1) = \{00, 01, 11, 100, 101\}$. Extending to level-3 $S(0, 1, 00) = \{01, 11, 100, 101, 0000, 0001, 0011, 00100, 00101\}$ and so on.

T-codes also have a useful synchronization property that if certain bits are lost in the stream, the T-code can self-synchronize unlike other codes which will invalidate the whole stream. T-code has good error recovery characteristics [14] in addition to being a source-coding algorithm.

F. Correlated Source Coding

A family of codes specifically designed to exploit the spatio-temporal correlations in the sensor data to achieve a lower bit-rate closer to the rate predicted by Slepian-wolf theorem [3] were chosen and evaluated. According to the Slepian-Wolf if X,Y are two correlated sources a source coding bit-rate of $R(X, Y)$, such that $H(X) + H(Y) \geq R(X, Y) \geq H(X) + H(Y|X) = H(Y) + H(X|Y) = H(X, Y)$ is achievable called as the Slepian-Wolf limit for the correlated source coding schemes.

1) *Modulo code*: Modulo code uses modulo coding for either the odd or even nodes. For example, one node [say odd] encoder transmits the modulo-N value of data, and for other node[even] the encoder transmits original data. At the receiver, decoder computes the *closest* multiple of N, which on adding with the residue from odd node, approaches as close as possible to the data from the even node. Generally $n = 2^k$ or $n = 8$ for practical purposes.

Error-free decoding is achievable if and only if data from 2 sources lie in the same $8.k$ bin. Example 40, 44 can be encoded as 40, 4 and decoded correctly. But 40, 35 are encoded as 40, 5 are decoded wrongly as 40, 37. This correlation model is restricted to cases where the data from 2 sources lie in the same bin.

2) *Haar Wavelet codes*: Integer Haar wavelet [4] transform models correlated data between the two sources by computing the low-pass and high-pass coefficients of the data. This scheme in its simplest form was used in the experiment as a 1-level Integer Haar transform by computing the sum & difference of the data from the two nodes which correspond to the LP & HP Integer Haar coefficients. This is a type of joint-encoding technique which can also be used in hierarchical sensor networks for scalable and lossless transforms with low bit rates, as shown in [4].

3) *DISCUS*: Distributed source coding using syndromes [6] is a generic technique to design source codes that reach the Slepian-Wolf limit. The basic premise is to model the correlation between sources as a type of channel noise and then choose a particular type of partitioned channel code for source coding. If the channel code can tolerate and perform well against this type of noise, then it is argued in [8], that the corresponding source code will perform well against the correlated data, treated as noise. The correlation between the two data sources is measured in terms of the Hamming distance of their data, which need to be $H_{dist} \leq t$, where t is the error-correcting capacity of the code.

In this implementation, the standard (7,4) Hamming code was split into two sub-codes and distributed encoding was done. The correlation model can tolerate the samples to be off by at-most $t = 1$ bits; for larger Hamming distance between the two source codes are the sources errors in this scheme. By this 7 bits of information were represented as just 5 bits owing to the correlation model assumed. The two 5 bit samples were decoded jointly at the decoder and their respective 7 bit versions were produced with a tolerable channel error upto 1 bit. This model is the simplest possible of the DISCUS codes

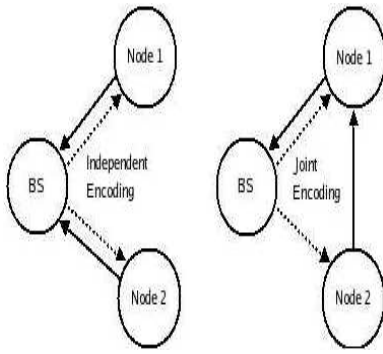

Fig. 1. Network architecture

achieved in practice. The DISCUS implementation follows description of [8].

III. EXPERIMENTAL SETUP

A. Network

3 MICA2 motes, arranged in either of the configurations shown in [Fig 1], were used.

B. Hardware

In this paper, the MICA2 motes in the RF frequency band 433MHz (MPR410) were used for experiment purposes. The Motes use the Chipcon CC1000, FSK modulated radio and Atmega 128L micro-controller.

C. Data collection

The data for the experiment were collected from the photo sensor by walking randomly around the lab, and varying light intensity by turning on/off the lights, or varying the window blind positions and gradually changing the light and shade to adjust light intensities on the photo sensor.

For pseudo-sensor codes, the data itself was simulated from the MICA mote, so a sensor board was not needed.

D. Operation

The base station was turned on after the two sensor nodes. The base station was connected to the PC via UART. After decoding, base station forwarded the data received from the sensor nodes to the PC. The data was read from PC serial port and saved into a log file for performance analysis.

IV. IMPLEMENTATION

The experiment was performed at a sampling rate of 2Hz, and tested up to 125Hz for two nodes. No scaling problems or dropped packets were observed in this scaling of sampling rates. Encoder and decoder latency was observed to be around the same values at various sampling rates, as reported.

A. Base station

The base station was designed conceptually as shown in [Fig 2]. It decoded the received packets, logged it to the PC and checked if the sensor nodes needed to be resynchronized and broadcasted the message.

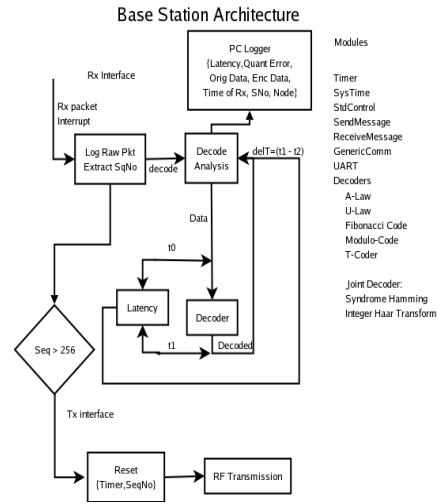

Fig. 2. Base station architecture

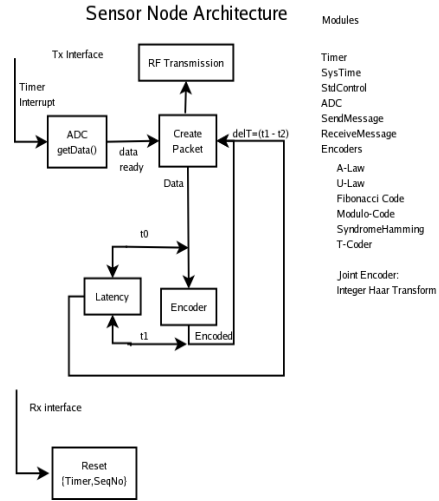

Fig. 3. Sensor architecture

B. Sensor Node

The sensor node [Fig 3] periodically sent out the encoded ADC data to the base station. It also resynchronized itself on receiving any packet from the base station.

C. Communication

Immediately after the base station was turned on, a broadcast message was sent to reset the sensor nodes and the base station waited for the data packets. Sensor nodes were programmed to access the channel in a mutually exclusive manner and sent their encoded samples to the base station. Once the sequence number reached 255, the base station reset the broadcast message and the whole process was repeated.

1) *Packet formats:* Transmitter packet format from sensor to the base station is in Table 1. Most of the fields are self descriptive. Length field represents the number of bits of the coded data. Latency is the time taken for the encoding operation, in microseconds. Original data is the MSB 8 bits

TABLE II
PACKET STRUCTURES

Sensor Data		PC Data		Broadcast Data	
Field	Byte	Field	Byte	Field	Byte
NodeID	1	SensorData Pkt	9	Command	2
Sequence#	1	decodeData	2	Timer	2
codeData	2	decodeLatency	2	Sensor	1
originalData	2	receiveTime	4		
Length	1	overflow	2		
Latency	2				

Epoch-based Timing & Synchronization Diagram [Illustration]

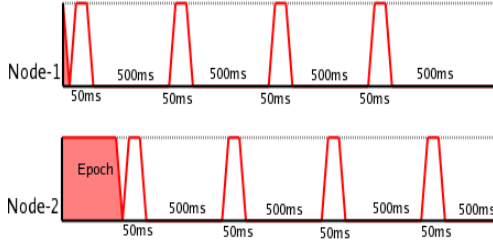

Fig. 4. Time multiplexing between two nodes.

of the 10 bit ADC samples.

Base station broadcast reset message was done via a packet structure shown in Table 1. Command field was used to request an action to be performed at the sensor node. Timer interval was the global time to which all sensors must synchronize with. Sensor field represents the type of sensor data requested; photo sensor was used in our implementation. Command and Sensor fields can be extended to support various commands.

The base station decoded the packets from the Transmitter sensor, appended extra fields and forwarded the packet to the PC via the UART using a packet structure shown in Table 1. The extra fields concatenated with the Transmitter packet are again self explanatory. All the time units are in microseconds. Overflow exists to count the number of dropped packets at high sampling rates.

2) *Channel Access*: Scheduling of the sensor nodes was done by allocating fixed time slots in a mutually exclusive manner, as in [Fig 4]. This is a simplified version of TDMA based MAC protocol.

D. Code

The application was written in NesC on the TinyOS system. Also various tools were used in the experimental setup:

TABLE III
CODE STATISTICS

Lines of Code	Language	Description
>3000	NesC	implementation
>200	C	testing
>1000	Octave	analysis & plotting
>100	Python	conversion,build-process
>100	Java	serial I/O formatting

1) *Statistics*: The source code for the entire application is available at [22].

TABLE IV
IMPLEMENTATION CODE SIZE

Code Type	ROM [bytes]		RAM [bytes]	
	B	S	B	S
μ -law	0	0	314	280
A-law	0	0	314	280
Fibonacci	0	0	586	544
Fibonacci (pseudo)	0	4	584	1328
Modulo-8	1	0	64	14
T-code	0	0	546	540
T-code (pseudo)	0	4	546	1190
Haar	0	3	82	512
DISCUS	2	0	1238	1292
DPCM	3	2	36	40

Implementation statistics for each of the source coders are given as increments to the reference implementation overhead (communication, startup etc) which occupies (excluding the given source coder) for base station 693b ROM, and 10270b RAM; and for the sensor node 452b ROM, and 10406b RAM.

2) *Testing*: All the source codecs [coder-decoder pairs] were written in a high-level language Octave [23] and tested. Next they are manually converted to C code which were subsequently converted into NesC. The unit-testing of each codec was done before the integration into the system and verified for its accuracy.

E. Codec Implementation

1) *Encoder*: The encoders for the codes A-law, μ -law, Fibonacci code, T-code [variant of Huffman code] were implemented as a Lookup Table(LUT). This basically creates a $O(1)$ time complexity encoder for all these cases with $O(n)$ storage space.

For the other encoders including Modulo code, Haar Wavelet code, DISCUS (variant of Hamming code), a similar constant-time encoder (Modulo,Haar) and linear-time encoder(DISCUS) were achieved using computation and not LUTs.

2) *Decoder*: The decoders for A-law, μ -law, Fibonacci code can be decoded by using a binary-search algorithm on the same LUT as the encoder with a known complexity of $O(\log(n))$. A $O(n)$ decoder has been implemented for the T-code using a LUT linear search. As the T-code LUT is built from frequency dependent data which are not always sorted, a binary-search algorithm cannot be used. For case of Modulo-code, Haar Wavelet and DISCUS-Hamming code, the decoding complexity is proportional to $O(n)$, for the Modulo-n case, $O(1)$ as it is just sum & difference, and $O(kn^2)$ as it involves a binary-matrix multiplication respectively.

F. Pseudo Data Sources

The entropy codes and universal codes were modeled with probability distributions different from the existing data source due to which the average bit rates were not optimal and in some cases (Fibonacci) caused expansion instead of compression. To overcome this problem, a deterministic pseudo-data

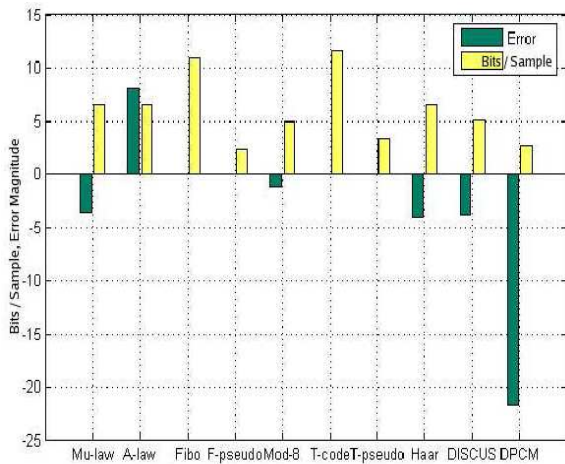

Fig. 5. Error Rate & Average bit rate measures for various codes

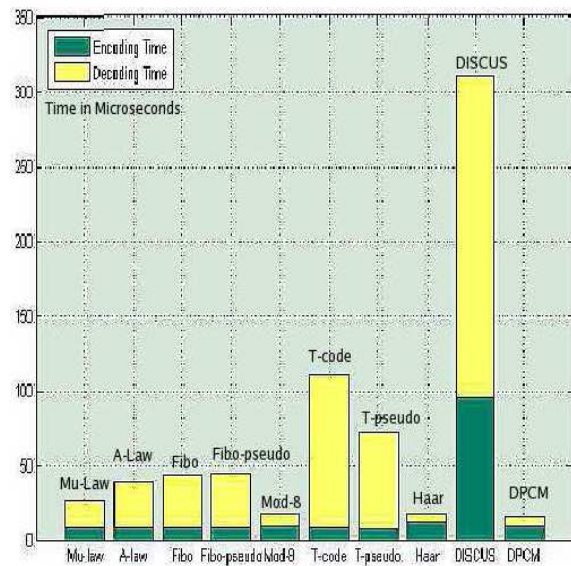

Fig. 6. Code encoding-decoding times for various codes

source was designed in the TinyOS platform in place of the photo sensor. The resulting probability distributions from these pseudo data sensors were used to re-design the codes LUT for T-code, Fibonacci codes. Codecs performing with pseudo-data sources were found to yield much better results closer to the optimum average bits/sample L_{avg} .

V. RESULTS

Various performance metrics were used in this experiment: *latency*, to show the encoding and decoding complexity of the code in our implementation, *energy utilized* in transmission as a function of message length, proportional to $430nJ/bit$ (as reported in [15]), *errors* due to decoding, quantization, *size* in bytes of codecs, and *computational complexity* of the codecs. The performance report is presented in [Tables 4,5,6,7].

Graphs for these various parameters are also shown [Fig 5,6,7]. The complete analysis for each of the codes is presented

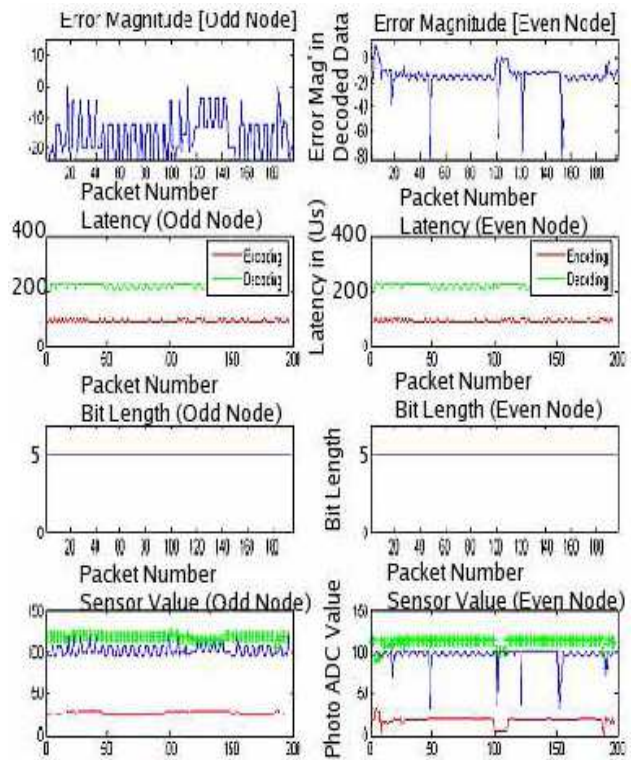

Fig. 7. DISCUS code performance for odd and even nodes with the real-time, coded, decoded data, bit rate and error performance with arriving packets. Graphs on left column correspond to the odd node and right column correspond to the even node. The Sensor value graph shows coded data in red, raw data in green, and decoded data in blue.

like the case of DISCUS code in [Fig 7].

VI. DISCUSSION

Evidently, the lossless codes have a slightly longer encoding time and a longer decoding time compared to the lossy codecs. On the other hand, the errors involved in lossless codes are zero while lossy codecs have significant errors. Similarly the average bit rates for the lossless codecs are seen to be higher than that of the lossy coders. Energy consumption of lossy codecs is much lesser than that of lossless codecs as it is proportional to the bit rate.

DPCM codes are sensitive to errors due to startup differences. DPCM errors propagate and affect other decoded samples. Such codes need to be implemented in a periodic or a per-frame coded manner.

In the encoding-decoding time graphs the anomalous peaks [Fig 7] are the artifacts due to the TinyOS scheduler and the overhead incurred due to the μs timer used. This is justified by the constant spike levels seen in that graph, and the other similar graphs obtained for various codecs which show a similar anomalies.

In this experiment, the Entropy codes (Huffman) and Universal codes (T-code and Fibonacci codes) were mapped on a non-specific source data and associated frequency tables due to which the average bit-rates are higher than the optimum

TABLE V
BIT RATE (ENERGY METRICS)

Code	Code Avg Bits	Total Error	
		μ	σ
μ -law	6.5447	-3.6159	2.1767
A-law	6.5408	8.0306	27.7193
Fibonacci	10.9765	0	0
Fibonacci (pseudo)	2.2864	0	0
Modulo-8	4.9435	-1.146	13.63
T-code	11.5928	0	0
T-code (pseudo)	3.3875	0	0
Haar	6.5242	-4.0544	55.4128
DISCUS	5	-3.7846	16.0268
DPCM	2.6175	-21.7274	17.3996

TABLE VI
COMPLEXITY

Code	Complexity		Implementation	
	Enc	Dec	Enc	Dec
μ -law	$O(1)$	$O(\log(n))$	LUT	Binary Search
A-law	$O(1)$	$O(\log(n))$	LUT	Binary Search
Fibonacci	$O(1)$	$O(\log(n))$	LUT	Binary Search
Modulo-8	$O(1)$	$O(\log_2 n)$	Compute	Linear Search
T-code	$O(1)$	$O(n)$	LUT	Linear Search
T-code (pseudo)	$O(1)$	$O(n)$	LUT	Linear Search
Haar	$O(1)$	$O(1)$	Compute	Compute
DISCUS	$O(n)$	$O(kn^2)$	Compute	Compute
DPCM	$O(1)$	$O(1)$	Compute	Compute

(where the probability distribution of the source model is known). Finding source probability distribution is possible in applications like traffic monitoring and environmental monitoring. Design of source codes for those applications are justified by this approach. T-code and Fibonacci code have a advantage over codes like delta-modulation and Haar-wavelet codes which reach the same bit rate or lesser, in terms of non-ergodic property and the error-recovery from the unsynchronized portions of code. DPCM codes are irreversibly damaged if there is a single error in the code for that corresponding frame whereas these entropy-based codes are much more reliable for use in sensor networks.

If prior knowledge of the dynamic range of sensor output is known, then a lossy compression scheme may be implemented by defining a transfer function between the sensor values and encoded output at the risk of introducing errors.

A LUT can be used to get the encoded value for every sample from the sensor. Then the problem of source coding and decoding reduces to reading an element off the LUT and finding the index corresponding to the element in the LUT. As expected, the lossy nature of the encoding schemes attribute to the error in decoding values and are only suited for loss tolerant applications and thresholding/on-off type of applications.

The decoding errors are considerably high for Modulo codes. The positive aspect of these codes is they require fewer bits to represent the data samples and hence lesser energy budget. So, when the perturbation in the input physical

TABLE VII
ENCODER-DECODER PERFORMANCE

Code	Encode		Decode	
	μ	σ	μ	σ
μ -law	8.6789	3.1452	17.5325	3.6159
A-law	8.9789	2.7132	29.9684	2.6435
Fibonacci	8.5729	2.2267	34.4219	4.787
Fibonacci (pseudo)	8.7805	2.4636	35.6940	2.9272
Modulo-8	9.4545	2.5748	8.405	0.4916
T-code	8.7451	2.1292	101.9477	69.6534
T-code (pseudo)	7.8000	1.7889	64.0750	25.4980
Haar	12.1862	3.6064	5.8866	0.3177
DISCUS	95.1515	29.3387	215.5455	4.5695
DPCM	9.1946	2.1936	6.1407	0.3483

variable is small, such source coding schemes are useful. The encoding latency is not much of an issue in both these coding schemes. But, unlike T-code, decoding latency in Modulo code is considerably higher due to complexities involved in decoding.

In case of Fibonacci codes, for the given link, the reconstruction of the original values from the sensor is perfect and decoding latency is well within $40\mu s$. The complexity involved is that of binary search in a bisected sorted space. But in this variable bit rate decoding, the average bit required to represent a sample is pretty high. This coding scheme will be valuable when the sensing environment is highly fluctuating, and near absolute reconstruction of the sensed values are required. Needless to say, it will take its toll in terms of transmission energy, as the average bit rate is twice as high as the other codes.

Since in real world applications we are not able to identify a priori the probability distribution of the source symbols, adaptive source coding techniques can be widely used. Schemes like Adaptive-Huffman coding can be implemented to achieve the adaptive coding methods, if somehow they can be implemented within the low-memory constraints and small decoding times, provided by the sensor platform.

A. Application Specific codes

A set of applications and specific source-codes suitable to them, are proposed as a result of the experiments.

TABLE VIII
APPLICATION SPECIFIC SOURCE CODE

Source Code	Application Type
Compander Code A-law, μ -law, DPCM	Fault Tolerant Systems, Event Detection
Entropy Codes T-code, Fibonacci	Mission Critical Systems, Data Forwarding
Correlation Codes DISCUS, Modulo-N, Haar	High Sampling Rate systems, Physical Process monitoring

B. Limitations of experiment

The known caveats and limitations of this implementation include:

- 1) Timing & Latency Measurement: These measurements were interrupt driven, and have a small but non-negligible overhead in time which was not considered. It is expected to have a sub- μ s overhead.
- 2) Noiseless Channel: No channel errors were considered or reported from the experiment in lab conditions. This is unlikely in a real world scenario.
- 3) Apriori source codes: Adaptive source codes were neither implemented, nor tested. Adaptive-Huffman code implementation on a sensor network is non-trivial.
- 4) Application: The sensor network application was prototype measurement system with no real-application, and only calibration and measurements at various points of the network.
- 5) Startup Errors: The first 2 packets in the joint-decoder schemes (Haar,DISCUS) are erroneous, due to the implementation.

C. Future work

Dynamic modulation code scaling (DMCS) [26] is a viable scheme in a heterogeneous multi-sensing network where many parameters are measured and processed at various levels of accuracy and importance. The framework of codes presented here, and their implementations allow easy implementation of a *dynamically modified* source-coding scheme at the network level and thus creating a new kind of optimized network.

Innovations in network coding [16], can also be explored to provide higher capacity to sensor networks by cooperative coding.

VII. CONCLUSION

This paper presents a study of source codes and their compact implementation for sensor networks. The results from the analysis of the data acquired from various source codes used in the network are mapped to suitable kind of applications in sensor networks according to the requirements in error, latency and energy consumption.

REFERENCES

- [1] Jason Hill, Robert Szwedczyk, Alec Woo, Seth Hollar, David Culler, Kristofer Pister, System Architecture Directions for Networked Sensors, ACM, ASPLOS-IX 11/00, Cambridge,MA.
- [2] Thomas Cover, Joy Thomas, Elements of Information Theory. New York: Wiley, 1991.
- [3] D.Slepian, JK Wolf, Noiseless coding of correlated information sources, IEEE transactions on Information Theory, 1973.
- [4] Jugoslava Acimovic, Efficient Distributed. Multiresolution Processing for Data gathering in sensor networks, ICASSP 2005.
- [5] S. Sandeep Pradhan, Kannan Ramachandran, Distributed source coding using syndromes (DISCUS): Design and construction, Proc. IEEE Data Compression Conference, Snowbird, UT, March 1999.
- [6] S. Sandeep Pradhan, Kannan Ramachandran, Distributed source coding: Symmetric rates and applications to sensor networks.
- [7] S. Sandeep Pradhan, Julius Kusuma, K Ramachandran, Distributed Compression in a Dense Microsensor Network, IEEE Signal Processing Magazine, 2002.
- [8] Stankovic, Liveris, Zixiang Xiong, Design of Slepian-Wolf codes, by Channel Code partitioning, 2004 IEEE, Computer Society, Data Compression Conference.
- [9] Wikipedia, http://en.wikipedia.org/wiki/Fibonacci_code/, 2006.
- [10] Wikipedia, http://en.wikipedia.org/wiki/A_law/, 2006.
- [11] Wikipedia, http://en.wikipedia.org/wiki/Mu_law/, 2006.
- [12] Zixian Xiong, Angelos D. Liveris, Samuel Cheng, Distributed Source Coding for Sensor Networks, IEEE Signal Processing Magazine, Sept 2004.
- [13] Higgin G.R, Database of best T-codes, IEE proc E. Comput. Digit. Tech. 133:54-64, 1986.
- [14] Anil Kumar, Navin Rajpal, Application of T-code, Turbo codes and Pseudo-Random Sequence for Steganography, Journal of Computer Science 2(2): 148-153, 2006.
- [15] Andreas Savvides, Network Embedded Systems & Sensor Networks Lecture 2: Sensing Platforms and Power Consumption Issues, Sept 2005.
- [16] Shou-Yen Robert Li, Raymond W. Yeung, Ning Cai, Linear Network Coding, IEEE Trans. Inform. Theory. Vol-49, No-2, Feb, 2003.
- [17] B.P.Lathi, Modern Digital and Analog Communication System, New York, pg:267-268, Oxford University Press, 1998.
- [18] Ian F. Akyildiz, Weilian Su, Yogesh Sankarasubramanian, Erdal Cayirci, A Survey on Sensor Networks, IEEE Communications Magazine, August 2002.
- [19] Thomas Haenselmann, An FDL'ed Textbook on Sensor Networks, 2006
- [20] Rex Min, Manish Bharadwaj, Seong-Hwan, Nathan Ickes, Eugene Shih, Amit Sinha, Alice Wang, Anantha Chandrakasan, Energy-Centric Enabling Technologies for Wireless Sensor Networks, IEEE Wireless Communications, Aug 2002.
- [21] Leonard E. Miller, Wireless Technologies and the SAFECOM SoR for Public Safety Communications, NIST Gaithersburg, MD, 2005.
- [22] Muthiah Annamalai, WSNSrcCoding: NesC code for data compression on TinyOS & MICA2 motes <http://students.uta.edu/mx/mxa6471/WSNSrcCoding/>
- [23] John W Eaton, GNU Octave: A free Matlab like scientific computing language : www.octave.org, Octave-2.9.3.
- [24] Holger Karl, Andreas Willing, Protocols and Architectures for Wireless Sensor Networks, John Wiley & Sons, England 2005
- [25] David Salomon, Data Compression 3, ed, Springer Verlag, 2002.
- [26] Curt Schurgers, Olivier Aberthorne, Mani B. Srivastava, Modulation Scaling for Energy Aware Communication Systems, ISLPED'01, 2001, ACM.
- [27] Alistair Moffat, Andrew Turpin, Compression and Coding Algorithms, 2002, Kluwer Academic Publishers.