

# Architectures for a quantum random access memory

Vittorio Giovannetti<sup>1</sup>, Seth Lloyd<sup>2</sup>, Lorenzo Maccone<sup>3</sup>

<sup>1</sup>*NEST CNR-INFM & Scuola Normale Superiore, Piazza dei Cavalieri 7, I-56126, Pisa, Italy.*

<sup>2</sup>*MIT, Research Laboratory of Electronics and Dept. of Mechanical Engineering,  
77 Massachusetts Avenue, Cambridge, MA 02139, USA.*

<sup>3</sup>*QUIT - Quantum Information Theory Group, Dipartimento di Fisica  
“A. Volta” Università di Pavia, via A. Bassi 6, I-27100 Pavia, Italy.*

(Dated: November 12, 2008)

A random access memory, or RAM, is a device that, when interrogated, returns the content of a memory location in a memory array. A quantum RAM, or qRAM, allows one to access *superpositions* of memory sites, which may contain either quantum or classical information. RAMs and qRAMs with  $n$ -bit addresses can access  $2^n$  memory sites. Any design for a RAM or qRAM then requires  $O(2^n)$  two-bit *logic gates*. At first sight this requirement might seem to make large scale quantum versions of such devices impractical, due to the difficulty of constructing and operating coherent devices with large numbers of quantum logic gates. Here we analyze two different RAM architectures (the conventional fanout and the “bucket brigade”) and propose some proof-of-principle implementations which show that in principle only  $O(n)$  two-qubit *physical interactions* need take place during each qRAM call. That is, although a qRAM needs  $O(2^n)$  quantum logic gates, only  $O(n)$  need to be activated during a memory call. The resulting decrease in resources could give rise to the construction of large qRAMs that could operate without the need for extensive quantum error correction.

PACS numbers: 03.67.Lx, 03.65.Ud, 03.67.-a

Random access memory (RAM) is a highly versatile device for storing and accessing information. It consists of an array of memory cells where information is stored in the form of bits. Each cell is associated to a unique address, i.e. a number which identifies the location of the cell. The main characteristic of a RAM is that each memory cell can be separately addressed at will, whence the designation ‘random access’. To access a cell, its address must be provided in an input register (the *index register*). The device will then output the content of the memory cell in a second register (the *output register*) [1]. If the input register is composed by  $n$  bits, the RAM is capable of addressing  $2^n$  different memory locations: when given an  $n$ -bit address  $k$ , the RAM returns the bit string  $f_k$  which was stored in the memory slot of the database labeled by  $k$ .

A quantum random access memory, or qRAM, is a RAM that functions in a way that preserves quantum coherence [2]. Compared to its classical counterpart a qRAM has the additional feature that it allows quantum superposition of addresses: given an input address state  $\sum_k \alpha_k |x\rangle_Q$  it returns the output state  $\sum_k \alpha_k |k\rangle_Q |f_k\rangle_A$  (here Q and A are, respectively, the quantum analogous of the index register and of the output register). Just as classical RAMs are highly useful devices, quantum random access memories will form an essential part of any large-scale quantum computer. Quantum random access memories that access *classical* information in quantum superposition could be used to give exponential enhancements of a variety of data processing tasks, such as pattern recognition [3, 4, 5, 6] and is necessary to implement quantum searching on a classical database [2]. More generally, a qRAM capable to access either classical or quantum memory arrays is a fundamental ingredient

for many known and new algorithms, such as quantum searching [7], collision finding [8], element-distinctness in the classical [9] and quantum [10] settings, the quantum algorithm for the evaluation of general NAND trees [11], or new algorithms such as to enforce privacy in database searches [12], or to route signals coherently through a quantum internet [13].

Conventional designs for classical and quantum RAMs require  $O(N = 2^n)$  two-bit or two-qubit logical operations in order to perform one memory call. At first sight this makes large scale quantum implementations impractical without the use of extensive quantum error correction. In this paper we show that there exists a routing algorithm, the “bucket-brigade” introduced in Ref. [14], which requires only a small number ( $O(n)$ ) of two-qubit interaction to implement a memory call. Even though the number of logic gates in the system is necessarily exponential, only  $O(n)$  of those gates need be activated in the course of a qRAM memory call. A classical RAM that uses the bucket-brigade addressing schemes need only activate  $O(n)$  transistors in the course of a memory call, in contrast with a conventional RAM that activates  $O(2^n)$  transistors. As a result, a RAM that uses our design might operate with less dissipation and power consumption than a conventional RAM. Note, however, that energy costs in the memory addressing are not sufficiently high in current RAM chips to justify an immediate adoption of the bucket-brigade. Other sources of inefficiencies and dissipations are currently predominant (mostly in the memory cells themselves). However, new promising memory cell technologies are being developed (e.g. the “memristor” cells [15]), which would drastically cut back cell dissipation, so that cutting back dissipation in the addressing may become important in the future.

In the quantum regime, the addressing scheme might allow the construction of a relatively large quantum RAM without the need for costly quantum error correction.

The outline of the paper follows. We start by analyzing the two different RAM architectures: the conventional (fanout) architecture [2] and the bucket-brigade architecture [14]. In the latter, the control lines that route the signals to the destination memory cell are replaced by memory elements that control the routing. The result is an exponential decrease in the number of two-body interactions required to implement the routing and to address memory. Both these architectures can be used in the quantum regime. We conclude the paper by giving some physical implementations of both qRAM schemes.

## I. DESCRIPTION OF THE PROTOCOL

To describe the qRAM algorithm, it is convenient to start from the analysis of its classical counterparts.

In the conventional ‘fanout’ addressing scheme, the index register specifies the direction to follow to reach the memory cell we are interested in. In particular, writing the index register in binary form, each bit of such register can be interpreted as the direction to take at a bifurcation of a binary tree. Since the  $n$  bits encode the directions to take at  $n$  bifurcations, then  $2^n$  different paths can be described this way.

A realization of such indexing procedure is presented in Fig. 1 part a). We call it the ‘fanout’ RAM scheme, since each address bit fans out to control several switches placed on different nodes of the tree. In particular the  $k$ 'th bit of the index register acts as a controller for  $2^k$  switches: if the bit has value 0 *all* the switches under its control will point ‘up’, otherwise they will all point ‘down’. By looking at Fig. 1, it is easy to see that for every state of the index register only one out of the  $2^n$  possible paths has all the switches in a ‘conducting’ state: a signal will follow the path to the memory cell we are interested in. The main drawback of the fanout architecture is that it requires simultaneous control over all the  $2^n - 1$  nodes of the binary tree even though only  $n$  nodes directly participate to the addressing of a given memory cell (these are the switches which lie along the path to the addressed memory cell). Fanout schemes are commonly implemented in RAM chips [1] by translating them into electronic circuits where the switches of the binary tree are replaced by pairs of transistors — see Fig. 1b). Notice that the number of activated transistors can be reduced to  $O(n)$  with a more clever arrangement. In Fig. 2 we modify the fanout RAM to attain a circuit where at each level of the binary tree only two transistors are activated, and where at the final stage only a single transistor is activated to open up the unique path to the desired memory slot. In total only  $2n + 1$  transistors are activated for every memory call. However, it is important to note that the few last bits in the index register are connected (in the last levels of the tree) to an

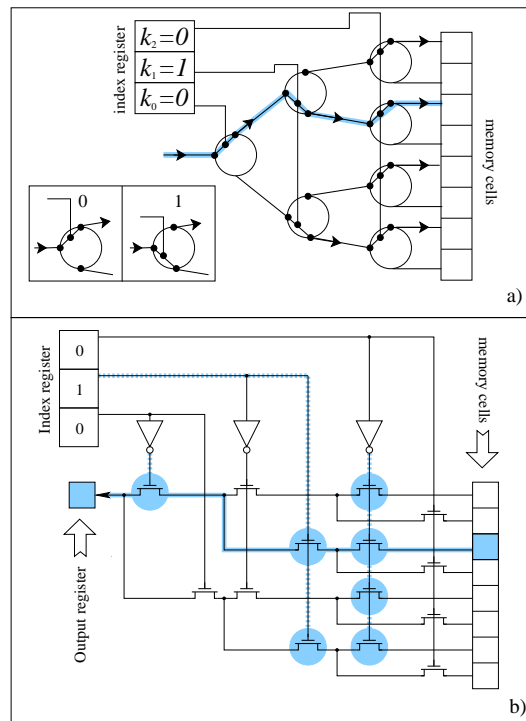

FIG. 1: (Color online) Part a): Schematic of the fanout addressing scheme. The bits of the index register control the switches (black circles in the picture) placed at the nodes of a binary tree. The thick path corresponds to the address where all the switches are in a conducting state. It leads to the memory cell that is to be addressed. Part b): typical electronic implementation [1]. Each bit of the index register is encoded via dual rail logic in the conducting states of two electric wires (vertical lines in the picture). The logical switches are represented by pairs of transistors that are controlled by the index register through the vertical wires (the total number of transistor is  $2(2^n - 1)$ ). The output register is connected to the memory cells through  $2^n$  paths each containing  $n$  transistors. For each value of the index register only one of the paths has all transistors active (the thick path in this example). For each memory call half of the transistors of the system are activated (the circled one in the picture) but only  $n$  of them directly participate to the addressing (the ones which lie on the thick path). The triangles represent NOT gates.

exponential number of transistors. Hence, this architecture would not be more helpful in the implementation of a quantum RAM than the conventional fanout architecture, as they both require the maintenance of quantum coherence over an exponential number of connections.

An alternative addressing scheme [14] can be designed by changing the function of the  $2^n - 1$  switching elements in the binary tree. We name this procedure ‘bucket-brigade’ since both the routing and the input-output signals are passed along the same route, like buckets of water passed along a line of improvised fire-fighters. In each node of the binary tree we place a three-state logic element (a ‘trit’), which can store the values 0, 1 or •,

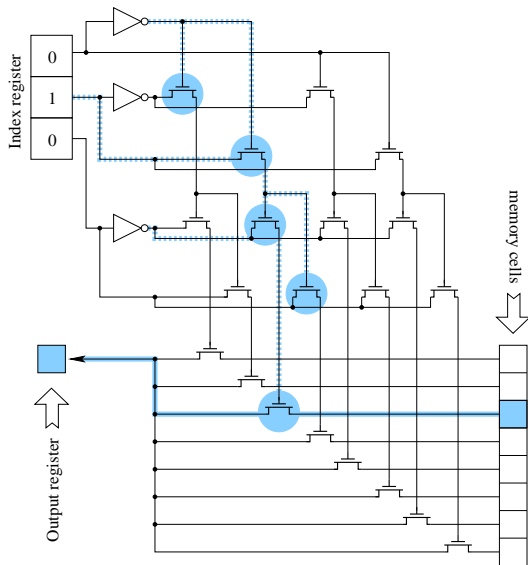

FIG. 2: (Color online) Modification of the conventional fanout circuit of Fig. 1b. This architecture achieves memory addressing with the activation of only  $O(n)$  transistors.

where  $\bullet$  is a passive or ‘wait’ state — see Fig. 3a). A trit in the state 0 or 1 acts as a switch that routes the signals transiting through its node “up” or “down”, respectively. A trit in the state  $\bullet$  does not propagate the signals transiting through its node, but changes its state to match the one of the arriving bit. Initially all the trits are in the ‘wait’ state  $\bullet$ . Now each bit of the index register is sent into the binary tree, one at a time. When one of these bits encounters a trit in the state  $\bullet$ , its value is transferred to the trit, which enters one of the two switching states, 0 or 1. A trit in the state  $\bullet$  that receives a 0, itself becomes 0, and routes all subsequent signals along the 0 branch of its node of the binary tree. Similarly, a trit in the state  $\bullet$  that receives a 1 becomes 1, and routes all subsequent signals along the 1 branch. After all the  $n$  bits of the index register have been sent through the binary tree, a route has been carved through it:  $2^n - (n+1)$  of the trits in the binary tree still have value  $\bullet$ , but any incoming signal will only encounter the  $n$  trits with value 0 or 1 which will route it to the one destination (out of the  $2^n$  possible ones) that was initially encoded in the index register.

### A. Quantum RAM

Both the fanout scheme and the bucket-brigade scheme can be turned into quantum RAM algorithms by transforming them into reversible processes and by requiring quantum coherence to be preserved. In abstract terms this is done by sending a quantum signal (the *quantum bus*) back and forth in the binary trees of Fig. 1 and 3, and by coupling it with the memory cell through C-NOT

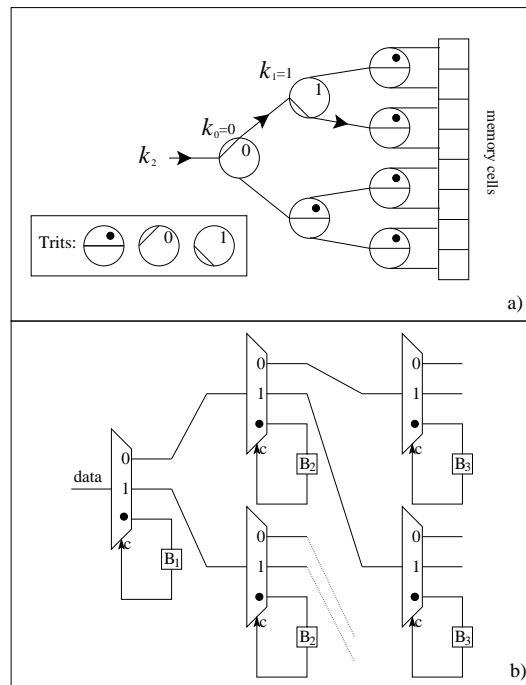

FIG. 3: Part a): Schematics for the bucket-brigade addressing scheme [14]. Each node of the binary tree is a trit i.e. a logic element characterized by the internal states 0, 1 and  $\bullet$ . A trit in 0 or 1 acts as a switch that routes the signals transiting through its node “up” or “down”, respectively. A trit in the  $\bullet$  state do not propagate the signals transiting through its node, but changes its state to a logical state 0 or 1, to match the one of the arriving bit. Part b): Electronic implementation of the bucket-brigade. The trapezoids are multiplexers based on trit-state logic [16] which route any incoming signal to the output determined by the control lines “c”. Suppose that initially all the memory elements  $B_1, B_2$ , etc. are in the state  $\bullet$ . Any incoming signal is then routed to the memory element itself, which is then switched to the value of the incoming signal. Any subsequent signal will be routed along the 0 or 1 paths depending on the value that had arrived previously. An internal clock resets all the memory elements to the value  $\bullet$  after the  $2n$  clock cycles necessary for the memory addressing, so that the protocol can restart.

transformations.

We will see that in the quantum version of the fanout RAM, the  $k$ 'th index qubit is still required to control  $2^k$  bifurcations in the binary switching tree, creating a fragile macroscopic superposition. While such high fanout control gates are relatively straightforward in a classical setting, they are rather costly in a quantum setting, where amplifying a signal makes it prone to decoherence. In particular, a qubit that interacts with  $2^k$  quantum switches is highly likely to decohere as  $k$  increases, even if its interaction with any given switch is small. In Sec. II we will present optical and solid state implementations of high fanout control gates. Because of their exponential character such gates must inevitably succumb to problems of noise and decoherence as  $n$  gets large. The gates

of the fanout architecture must then introduce errors which scale as  $O(2^{-n})$  (as the first gates in the bifurcation tree are responsible for an exponential number of paths, while the last gates in the bifurcation tree are coupled to an exponential number of paths). Nonetheless for small  $n$ , useful fanout qRAMs might be implementable along the lines proposed. In addition, fanout qRAM designs are instructive as they allow us to identify failure mechanisms as  $n$  gets large.

In contrast, the quantum version of the bucket-brigade addressing scheme does not suffer from this problem: even though the number of components of the device is  $O(2^n)$ , the number of control gates that needs to be performed in each memory call is only polynomial in  $n$ . As a result, bucket-brigade qRAMs might be scalable to large sizes, even with relatively high switching error rates. If the error rate per switching event is  $\epsilon$ , then the overall error rate per memory call is  $n\epsilon = \log_2 N\epsilon$ . This implies that the bucket-brigade can operate also if its gates introduce errors which scale as  $O(1/n)$ , in contrast to the fanout architecture. For example, a per-switch error rate of 1% allows one to address  $2^{10} \approx 10^3$  memory locations in quantum superposition with an overall error rate of 10%,  $2^{20} \approx 10^6$  memory locations with an overall error rate of 20%, and  $2^{30} \approx 10^9$  memory locations an overall error rate of 30%. Because of the exponential improvement of the bucket-brigade over fanout designs, a small change in the error rate can lead to a dramatic improvement in performance. A per-switch error rate of 0.1% allows one to address  $2^{100} \approx 10^{30}$  memory locations in quantum superposition with an error rate of 10%.

In addition to employing the fanout or the bucket-brigade architectures, it is possible to use a combination of the two. In this case, there is a trade-off between the amount of coherent control and the number of quantum memory elements that are necessary.

### 1. Fanout quantum RAM

To quantize the fanout RAM, we employ a quantum bus. This is a quantum system that can be routed coherently along every one of the  $2^n$  possible paths of the binary tree and which is characterized by some internal degree of freedom that can be used to store and process information. At each bifurcation in the path, the choice of the route (“up” or “down”) is performed in a quantum-controlled fashion, i.e. by using a unitary routing transformation controlled by the corresponding qubit in the index register. As in the conventional fanout RAM, the  $k$ 'th index qubit in index register of a fanout qRAM controls  $2^k$  bifurcations.

The  $n$  quantum controlled transformations along the binary tree convert the binary value of the index register Q into the position of the bus system. This transformation is a binary-to-unary translation: the binary address stored in the index register is translated into the unary variable consisting of the position of the bus. The

bus system then locally interacts with the memory cell placed at the exit of the path that it followed. If the index register Q contains a superposition of addresses, then the bus system follows more than one path in superposition and locally interacts with all the memory cells relative to these paths. (More precisely, the position of the bus becomes entangled with the state of the index register.) This interaction coherently copies the content of the memory cell into the internal degree of freedom of the bus system. In the case in which the each memory cell of the database contains a single bit of information, the quantum bus is a single flying qubit and the copy operation is a single C-NOT gate. If, instead, each memory cell contains  $d$  bits of information we can either use a single quantum bus with  $2^d$  internal states, or we can transfer the information bit by bit with a single two-dimensional quantum bus by repeating the whole process  $d$  times.

At this point, even though the desired information has been transferred to the bus, the user cannot yet access it in quantum superposition, since the value of the Q register is still correlated (more precisely, entangled) with the position of the bus system. Since we want to preserve the quantum coherence, this correlation must first be removed. This can be achieved by “uncomputing” the binary-to-unary translation, i.e. by running the translation backwards. In practice, this means that the bus system must be sent back along the quantum-controlled binary tree: at each bifurcation the controlled-Unitary transformations decorrelate the value of the controlling qubit in the  $n$  register from the bus system, which is thus routed back to the binary tree entrance. Now, we just swap the state of the bus's internal degree of freedom to the output register A. The final result is that the uncomputation has decorrelated the bus system from the index register Q, and the answer register A contains the state of the memory cell (cells) addressed by Q. If Q is initially in a superposition of address states, after the quantum memory call has been completed, Q and A are in an entangled state, with each address in Q perfectly correlated with the corresponding output in A.

### 2. Bucket-brigade quantum RAM

To quantize the bucket-brigade procedure, in each node of the binary tree we place a three-level quantum system (a “qutrit”). If it is in the state  $|0\rangle$  or  $|1\rangle$ , then the qutrit acts as a quantum switch, routing the subsequent incoming qubits “up” or “down”, respectively. If, instead, the qutrit is in the state  $|\bullet\rangle$ , then a unitary operation  $U_s$  stores any incoming qubit by swapping the qubit's state into the state of the qutrit's first two levels. The qubits of the Q register are sequentially sent through the apparatus: the state of the  $k$ th index qubit is stored in exactly one qutrit at the  $k$ th level of the tree and routes the subsequent qubits according to its state. After all the  $n$  qubits of the Q register have gone through the tree,  $n$  quantum switches are active (i.e. in a state

$|0\rangle$  or  $|1\rangle$ ).

At this point, we send a bus qubit into the tree: it reaches the end of the tree where it meets with one of the  $2^n$  memory cells (when the index register is in a superposition of addresses, the bus qubit can meet more than one cell, in superposition). Now the state of this memory cell is coherently copied into the bus. The uncomputation needed to decorrelate the position of the bus qubit can be easily performed by reflecting it back into the binary tree: the qutrit-switches route it back to the entrance of the tree. Finally, the loading of the qutrits must be reversed. Starting from the last level of the tree, the unitary  $U_s^\dagger$  is applied so that the qubits of the Q register are recovered one by one and routed back to the entrance of the tree. After  $U_s^\dagger$  has been applied to all levels of the binary tree, the Q register has been recovered and the qutrits in the tree have all been restored to the state  $|\bullet\rangle$ . At the conclusion of the entire process, the Q register is decorrelated from the binary tree and the bus qubit contains the value of the accessed memory cells. Notice that, even though this procedure requires the existence of a total number of qutrits of the order of  $2^n$ , only  $n$  of them are active in any run of the protocol.

## B. Generalizations

It is worth pointing out that the qRAM schemes we have presented in the previous sections do not require the information contained in the addressed memory cells to be classical. Indeed the whole architecture still works also in the case in which the information stored in the memory cells is purely quantum. Of course in this case the no-cloning theorem [17] forbids us to “copy” the quantum data in the output register A: the protocol will simply delocalize the information originally contained in the addressed memory cell into an entangled configuration of the cells and A. In fact, the procedure that copies classical information, i.e. the C-NOT gate, in general will entangle quantum information on which it acts. Alternatively, a swap operation can be performed to transfer the quantum information to the bus. The bus can then transfer the quantum information out of the qRAM, at which point it can be sent to some desired destination. The type of quantum data processing that one implements on the memory states of the qRAM depends on the application one is interested in. Notice that, in contrast to the case of classical memory cells, a qRAM procedure based on either the swap or the C-NOT transformations will generally leave the memory array entangled with the index and output registers Q and A at the end of the procedure.

Before proceeding we note also that it is possible to reduce the number of circuit elements in all the above implementations by using more clever geometric arrangements of the memory array. Typically, a bidimensional array is used, and the index register is divided into two parts, one of which indexes a row in the memory array,

the other a column. If rows and columns have the same size, we can reduce the number of necessary circuit elements to the square root of its original value, and still address the same number of memory cells. More complex arrangements (such as using three-dimensional memory arrays) would entail a further reduction of circuit elements, but are not typically used as they require much more complex wiring diagrams. With this in mind, in the rest of the paper we will concentrate on the case of one-dimensional memory arrays for the sake of simplicity.

## II. PHYSICAL IMPLEMENTATIONS

The basic concept of a qRAM dates to the early days of quantum computing, when researchers first began considering quantum computer architectures: a sketch of an optical fanout qRAM scheme can be found in Ref. [2]. In this section we construct detailed physical designs for qRAMs, taking into account the possibility of hybrid encodings where the quantum bus and the memory cells are implemented by different physical objects (e.g. photons vs. trapped atoms). Finally, we present an implementation of the bucket-brigade scheme.

### A. Quantum optical implementation of the fanout qRAM

An optical implementation of the fanout qRAM is presented in Fig. 4. For the sake of simplicity we consider the case in which the memory cells contain a single bit. Here the value of index register Q is encoded in a binary fashion in the internal state of  $n$  atoms (ions) trapped into an optical lattice (magneto-optical trap). The  $2^n$  memory locations are addressed by translating this information on  $2^n$  different spatial modes of the electromagnetic field of a ‘bus’ photon characterized by polarizations  $|0\rangle$  and  $|1\rangle$ .

We start with the register Q prepared into the internal state of the  $n$  atoms of the following form:

$$|\Psi\rangle_Q = \sum_{k=0}^{2^n-1} \alpha_k |k_0\rangle_{Q_0} |k_1\rangle_{Q_1} \cdots |k_{n-1}\rangle_{Q_{n-1}}, \quad (1)$$

where  $\alpha_k$  is the amplitude that the register Q indicates the  $k$ 'th memory cell, and where  $k_i$  denote the bits of  $k$ , i.e.  $k = k_0 k_1 \cdots k_{n-1}$ . We prepare a single photon in the polarized state  $|0\rangle$  and shine it onto the first atom: The coupling among them is such that the atom acts as a controller for the polarization of the photon (see Fig. 5). Then we send the bus photon through a polarizing beam splitter and rotate its polarization back to  $|0\rangle$  (see Fig. 4). As a result, the spatial mode occupied by the bus photon is now perfectly correlated with the value of the first index qubit, through a C-NOT transformation. We repeat the above procedure, using the second atom,

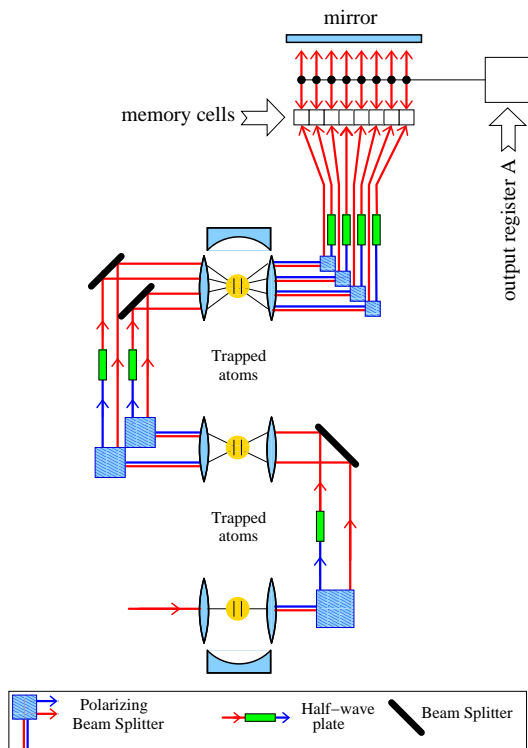

FIG. 4: (Color online) Schematic of the optical implementation of fanout qRAM model. The index register is encoded into the internal state of a collection of  $n$  two-level atoms trapped (the gray circles in the picture) in an optical lattice. The quantum bus is a single photon which can be prepared in two orthogonal polarizations (represented in the pictures by the double lines) and routed into  $2^n$  spatial modes. The routing algorithm begins by preparing the bus photon in one polarization state and by coupling it with the first atom of the trap. This copies in a coherent fashion the internal state of the atom in the polarization on the photonic bus. Using a polarizing beam splitter and a half-wave plate this information is then transferred into a spatial degree of freedom. The resulting two modes are then coupled to the next atom of the index register and the whole process is repeated  $n$  times. At the end of the routing, the atomic state is coherently mapped into the spatial degree of freedom of the bus photon. The photon then reaches the memory cells, where their information content is copied onto its polarization by a C-NOT operation (which does not produce entanglement, as the memory cells are in a classical state, 0 or 1). Then, its polarization state is swapped with the output register A which thus contains the value (or values, in superposition) of the addressed memory cells. Finally, the photon (its polarization having been reset by the swap) is reflected back through the setup: the interactions with the atoms reverse the routing algorithm so that the photon in a superposition of modes is routed back to the single mode from where it had originally entered the setup.

i.e. apply a C-NOT gate using the qubit  $|k_1\rangle$  as the control and the bus photon as the target. Note that the C-NOT transformation must be crafted in such a way as to be independent of the position of the target photon, as the bus photon is now in two different spatial modes. This can be achieved by letting the two spatial modes

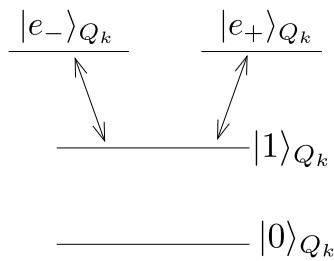

FIG. 5: Atomic level structure of the memory index elements. The  $k$ 'th qubit of the index register is stored in the stable levels  $|0\rangle_{Q_k}$  and  $|1\rangle_{Q_k}$  of the  $k$ 'th atom. The atomic state  $|0\rangle_{Q_k}$  does not interact with the photon. On the contrary, the state  $|1\rangle_{Q_k}$ , interacts with a  $|\pm\rangle = (|0\rangle \pm |1\rangle)/\sqrt{2}$ -polarized photon through a standard Jaynes-Cummings Hamiltonian which couples it with the ancillary levels  $|e_{\pm}\rangle_{Q_k}$ . The interaction time is such that the system experiences a cyclic transition  $|1\rangle_{Q_k}|\pm\rangle \rightarrow |e_{\pm}\rangle_{Q_k}|\text{vac}\rangle \rightarrow \pm|1\rangle_{Q_k}|\pm\rangle$  [19] (here  $|\text{vac}\rangle$  is the photonic vacuum). Consequently, a photon with polarization  $|0\rangle$  will get entangled with the atomic levels  $|0\rangle_{Q_k}$  and  $|1\rangle_{Q_k}$ .

interact with the gate at different times. Now again we can split the bus photon's spatial mode using polarizing beam splitters and then reset its polarization using polarization rotators, as before. The value of the first two qubits  $k_0$  and  $k_1$  has been transferred to four spatial modes (see Fig. 4). We then iterate the procedure until the values of all the  $n$  qubits of index register have been transferred to  $2^n$  spatial modes of the bus photon. Each of the  $2^n$  spatial modes of the bus photon interacts with the first bit of the corresponding location in the memory array. The interaction is such that the bus photon's polarization is rotated if the memory bit is 1. Now we swap the state of the bus photon's polarization into the output register A, which was previously initialized in  $|0\rangle$ . Since the polarization of the bus photon has been reset to  $|0\rangle$ , to invert the binary-to-unary encoding, it is sufficient to reflect the photon back through the whole setup [18].

Notice that, even though the  $k$ 'th address bit fans out to  $2^k$  controlled-controlled NOT gates, it only interacts with the bus qubit once: the number of physical interactions between information carrying degrees of freedom is exponentially smaller than the number of physical gates. This exponential-small paucity of interactions mirrors the classical case: in a classical fanout RAM, even though the  $k$ 'th address bit interacts with two sets of  $2^k$  transistors, the actual signal sent through the RAM to address the memory interacts with only  $n$  transistors.

## B. Phase gate implementation of the fanout qRAM

In this section we present a fanout qRAM implementation where the addressing is realized by a collection of controlled phase gates.

The main idea is to implement the binary tree as  $2^n$  cavities in which (at most) one photon is present (see



Fig. 6). The  $n$  qubits of the Q register fan out to induce phase shifts in all the cavities. If these shifts are chosen appropriately, the incoming photon can resonate in only the cavity indexed by the register Q. This can be achieved by using conditional phase shifters (the solid squares of the picture) controlled by the index register Q. Since there are  $2^n$  possible cavities, we need to devise a scheme which is extremely sensitive to phase shifts: the width of the cavity resonance window must be of the order of  $\pi/2^n$ , so that only one among cavities with similar phase shifts can be placed into resonance [20]. Such routing scheme can be realized in principle both in an optical environment analogous to the one of Sec. II A or in a solid state implementations [21, 22]. In the latter case photolithographic techniques permit the etching of micrometer scale solid-state qubits, e.g., superconducting charge or flux qubits, or electron spin quantum dots. These qubits can in turn be coupled to microwave cavities [21, 22]. While existing systems couple only a few qubits to the cavity, because of the small scale of the qubits (ranging from tens of nanometers for superconducting charge qubits or quantum dots to tens of micrometers for superconducting flux qubits) compared with the relatively large scale of the cavity (centimeters), in principle microwave cavities can be constructed so as to interact with a large number of such qubits simultaneously. The interaction of a single microwave photon with a large number of qubits can then be used to implement the large scale fanout required for a fanout qRAM. In this case the conditional phase shifters can be implemented, for example, following Ref. [22] and by requiring a single superconducting qubit which interacts with two microwave modes (one encoding the quantum bus and one encoding the index register degree of freedom). In this case the required effective Hamiltonian could be of the Jaynes-Cummings form. We need to operate the system far from resonance to ensure that the microwaves modes do not exchange excitations through this coupling — its only effect should be the insertion of a phase shift conditioned on the value of the qubit.

Once the routing has been performed the information is extracted from the memory cells by coupling each cell to one of the  $2^n$  cavities. In the implementation discussed above, for instance, this can be achieved by placing in each of the memory cell locations two superconducting qubits that are employed both to store the information in the memory cell and to extract this information to an outgoing photon. (Two qubits are needed in each cavity instead of one, in order to remove the feedback effect that the content of the memory cell would have on the cavity photon). If the cell stores a “one”, then the first superconducting qubit in the state  $|1\rangle$  and the second is in  $|0\rangle$ . This means that the first qubit induces a phase shift on the first outgoing photon, whereas the second qubit leaves the second outgoing photon untouched. If, instead, the cell stores a “zero”, then the states of the two superconducting qubits are reversed. With this procedure, the contents of the memory cell have been transferred

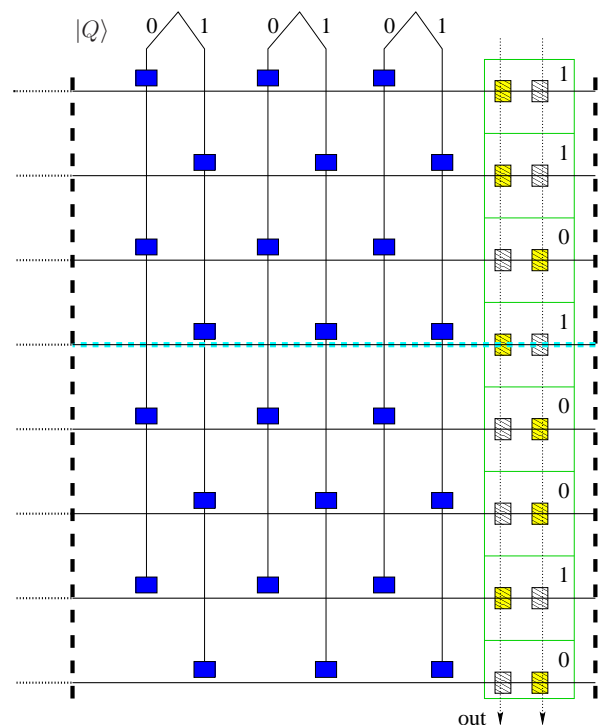

FIG. 6: (Color online) Phase gate implementation of the qRAM protocol. The dashed lines at the right and at the left indicate the microwave cavity. The solid rectangles indicate phase shifters controlled by the photons the Q register is encoded in (above). The hatched rectangles indicate phase shifters controlled by the cavity photon. These phase shifters are implemented by a qubit (see text), the state of which is determined by the memory cell contents. In this example the Q register is in the state  $|Q\rangle = |011\rangle$ , so that the system is addressing the fourth memory location (which contains a one): the only path in resonance is the one indicated by the thick dashed line.

to the two outgoing photons: the first is phase-shifted only if the memory contained a “one”, while the second is phase-shifted only if it contained a “zero”.

The circuit model of Fig. 6 can be used to construct a variety of designs for solid-state fanout qRAMs. A qRAM that is effectively the direct quantization of the classical fanout RAM could be constructed using single electron transistors and Coulomb blockade. For example, the index qubits could correspond to single electron transistors which, when activated, allow charge coherently to tunnel onto charge qubits, corresponding to the solid rectangles. These rectangles, when charged, in turn exert a Coulomb blockade on their corresponding lines in the binary switching tree. The quantum bus is implemented by a single electron, which is routed via the Coulomb blockade along the single unblocked branch of the tree. Of course, the difficulties in performing all the Coulomb blockade and tunneling steps in a coherent manner are formidable. Because the logical qubits in this system are all registered by the presence or absence of electrons, charge noise is likely to decohere the charge fanout qRAM

very rapidly. In the cavity solid state qRAM described in detail above, by contrast, coherence times are set by the coherence scale of the optical cavities used to perform the fanout and addressing. Such coherence times can be relatively long compared with charge qubit coherence times (microseconds compared with nanoseconds).

### C. Bucket-brigade implementation

In this Section we give a possible implementation of the quantum bucket-brigade scheme where the index register qubits are encoded into photons propagating along a network of coupled cavities that contain trapped atoms. The main idea is the following. In each node of the binary tree, the qutrit is implemented by an atom with the level structure given in the inset of Fig. 7. The levels  $|zero\rangle$  and  $|up\rangle$  are coupled to the “up” spatial paths in the tree (i.e. the dashed lines in Fig. 7), while the levels  $|one\rangle$  and  $|down\rangle$  are coupled to the “down” spatial paths (i.e. the dotted lines). Start the protocol by preparing all atoms in the level  $|\bullet\rangle$  and sending in a photon which encodes the first qubit of the Q register (alternatively one can replace polarization encoding with time-bin encoding). By turning on a strong laser field to induce a Raman transition, the photon will be absorbed and stored in the first atom in the  $|zero\rangle$  atomic level if it is in the state  $|0\rangle$ , and in the  $|one\rangle$  level if it is in  $|1\rangle$ . Now send the second photon which encodes the second qubit of Q: it will meet the atom in the state  $|zero\rangle$  or  $|one\rangle$  depending on the value of the first qubit. Again we use Raman transition technique to absorb (and subsequently re-emit) the photon in the  $|up\rangle$  level or in the  $|down\rangle$  level respectively. In the first case (since  $|up\rangle$  and  $|zero\rangle$  couple only to the “up” spatial path that connects to the subsequent level in the tree), the second qubit will move in the “up” path to the uppermost atom in the second node. Here it will be absorbed by the  $|zero\rangle$  or  $|one\rangle$  level of the second atom, depending on its value. In the second case, instead, the qubit follows an identical evolution, but on the “down” path, reaching the lowermost atom in the second node. Now the third qubit of Q is sent. It will follow a path along the first two bifurcations that is determined by the values of the first two qubits, and it will be absorbed in the  $|zero\rangle$  or  $|one\rangle$  level of one of the atoms of the third node, thus determining the path that the fourth qubit will follow, and so on. After all the qubits of the Q register have been stored in the respective nodes, a bus qubit initially in the state  $|0\rangle$  is sent through the apparatus. Thanks to the presence of the other qubits stored in the respective atoms, it will be directed to the memory cell that is addressed by the Q register, where the cell’s value will be copied onto it. Now this bus qubit can follow the binary tree backwards, exiting with the memory cell’s value. To conclude the protocol, all the atoms are made to emit their stored qubits backwards with sequenced Raman transitions, starting from the last node and progressing to the

first. The end result is that the memory cell’s content has been stored on the bus qubit, while all the qubits of the Q register have been re-emitted and are again available.

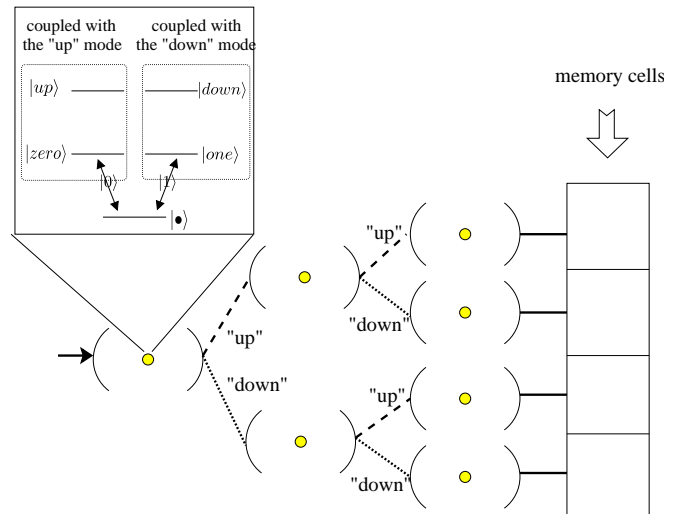

FIG. 7: Bucket-brigade implementation. At each node of a bifurcation tree, the three-state switch (the qutrit) consists of an atom in a cavity. Its level structure is given in the inset: The  $|0\rangle$  and  $|1\rangle$  transitions couple only to incoming qubits which are in the  $|0\rangle$  and  $|1\rangle$  states respectively. When the first qubit arrives, depending on its state, it will be stored in the  $|zero\rangle$  or  $|one\rangle$  level. When a subsequent qubit arrives, it will be absorbed and re-emitted by the  $|up\rangle$  levels or by the  $|down\rangle$  levels depending on the earlier qubit’s state. The  $|up\rangle$  levels are coupled only to the dashed arms of the binary tree, whereas the  $|down\rangle$  levels are coupled to the dotted arms, so that all the subsequent qubits are routed depending on the state of the previous qubits. The extra atomic levels needed to perform Raman transitions are not shown in the picture.

Because the bucket-brigade qRAM operates by sequential coupling of qutrits, it takes  $O(n^2)$  steps to retrieve one of  $2^n$  memories coherently. In the discussed implementation the nodes of the binary tree are atoms coupled via photons through Raman pulses. Alternatively they could be solid-state artificial atoms such as superconducting qubits or electron spin quantum dots, for which a variety of tunable coupling schemes that allow the desired interactions have been designed [23, 24, 25]. All such schemes will introduce errors, both via inaccuracies in the application of the classical fields required to induce interactions between qutrits, and via interaction with the environment. A key requirement is that the probability of passive states  $|\bullet\rangle$  being inadvertently excited to active states  $|zero\rangle, |one\rangle$  be small enough that signals are not routed along the wrong path. Essentially, as long as the error rate is significantly less than one over the number of steps required in a memory call (i.e.  $O(n^2)$ ) then the coherent memory call goes through with high probability.

Another way to think of the resilience of the qRAM in the face of noise and error is the following. If the memory address register is initially in a superposition of a large number, e.g., all, of the memory sites, then all pieces of



the qRAM circuit will be used during the coherent memory call. Because the bucket-brigade scheme for calling a single memory involves only  $n$  qutrits, however, *in each component of the superposition* only  $n$  qutrits will be active. Such superpositions are typically highly robust in the face of noise and loss [26, 27].

### III. CONCLUSIONS

Random access memory forms an integral part of computers and data processing protocols, whether classical or quantum. This paper showed how quantum random access memories (qRAMs) might be implemented by using quantum optical and solid-state quantum information processing techniques. We proposed a new paradigm for constructing both classical and quantum RAMs, the bucket-brigade paradigm, in which the degree of fanout required to perform a memory call can be reduced expo-

entially, from  $O(2^n)$  to  $O(n)$ . As a result, the memory-addressing portion of classical RAMs might be made more energy efficient, and large quantum RAMs might be constructed without recourse to expensive and difficult quantum error correction techniques. Such large-scale qRAMs could prove useful for fast pattern recognition algorithms and for communication and computation protocols in which one party wishes to access and process information without the provider of the information knowing who accessed the information or even what the information was.

### Acknowledgments

We thank Andrew Childs for pointing out references [8, 9, 10, 11]. VG acknowledges financial support of Centro Ennio De Giorgi of Scuola Normale Superiore of Pisa.

- 
- [1] R. C. Jaeger and T. N. Blalock, *Microelectronic circuit design*, (McGraw-Hill, Dubuque, 2003), pg. 545; A. S. Sedra and K. C. Smith, *Microelectronic circuits*, (Oxford Press, New York, 1998).
- [2] M. A. Nielsen and I. L. Chuang *Quantum Computation and Quantum Information* (Cambridge University Press, Cambridge, 2000).
- [3] G. Schaller and R. Schützhold, *Phys. Rev. A* **74**, 012303 (2006).
- [4] R. Schützhold, *Phys. Rev. A* **67**, 062311 (2003).
- [5] C. A. Trugenberger, *Phys. Rev. Lett.* **87**, 067901 (2001); *ibid.* **89**, 277903 (2002).
- [6] D. Curtis and D. A. Meyer, Proc. SPIE, *Quant. Comm. Quant. Imag.* **5161**, 134, (2004).
- [7] L. K. Grover, Proc. 28th Annual ACM Symposium on the Theory of Computing (STOC), pg. 212 (1996).
- [8] G. Brassard, P. Høyer, and A. Tapp, ACM SIGACT News (Cryptology Column), **28**, 14 (1997), preprint quant-ph/9705002.
- [9] A. Ambainis, Proc. 45th IEEE Symposium on Foundations of Computer Science (FOCS'04), pg. 22 (2004), preprint quant-ph/0311001.
- [10] A. M. Childs, A. W. Harrow, P. Wocjan, Proc. 24th Symposium on Theoretical Aspects of Computer Science (STACS 2007), Lecture Notes in Computer Science **4393**, 598 (2007), preprint quant-ph/0609110.
- [11] A. M. Childs, B. W. Reichardt, R. Spalek, S. Zhang, to be published in Proc. 48th IEEE Symposium on Foundations of Computer Science (FOCS'07), preprint quant-ph/0703015.
- [12] V. Giovannetti, S. Lloyd, and L. Maccone, *Phys. Rev. Lett.* **100**, 230502 (2008).
- [13] V. Giovannetti, S. Lloyd, and L. Maccone, unpublished (2008).
- [14] V. Giovannetti, S. Lloyd, and L. Maccone, *Phys. Rev. Lett.* **100**, 160501 (2008).
- [15] D. B. Strukov, G. S. Snider, D. R. Stewart, and R. S. Williams, *Nature* **453**, 80 (2008).
- [16] P. Horowitz and W. Hill, *The art of electronics, 2nd edition* (Cambridge Univ. Press, Cambridge, 1989).
- [17] W. K. Wootters and W. H. Zurek, *Nature* **299**, 802 (1982).
- [18] Depending on the practical limitations that might be present in an actual implementation, it is also possible to modify the above scheme in order to remove any dependence on an external register A. In fact, instead of employing  $2^n$  spatial modes in the bus photon, we can use twice as many and encode the first qubit of A directly on the bus photon's degree of freedom (using dual-rail logic). This means that, once we have obtained the unary encoding of the bus photon, we can transfer the first qubit of the memory into a dual-rail encoding on the  $2^n$  modes. We thus have to deal with  $2 \times 2^n$  modes, but we can reverse the algorithm of Fig. 4 separately on each of these two groups. We end up with a single photon in two modes, which encodes the value of qubit associated with the address  $|\Psi\rangle_Q$ .
- [19] Q. A. Turchette, C. J. Hood, W. Lange, H. Mabuchi, and H. J. Kimble, *Phys. Rev. Lett.* **75**, 4710 (1995).
- [20] In fact, the Heisenberg evolution of a cavity is given by [28]

$$\begin{aligned} b_l &= \kappa(\varphi) a_l + e^{i\varphi} \sigma(\varphi) a_r, \\ b_r &= \sigma(\varphi) a_l + \kappa(\varphi) a_r, \end{aligned} \quad (2)$$

where  $a_l$  and  $a_r$  are the cavity input fields (from the left and from the right respectively),  $b_l$  and  $b_r$  are the cavity output fields (from the left and from the right), and where  $\kappa$  and  $\sigma$  are the cavity transmissivity and reflectivity. These quantities are given by  $\kappa(\varphi) = \frac{\sqrt{1-\tau}(e^{i\varphi}-1)}{1-e^{i\varphi}(1-\tau)}$ ,  $\sigma(\varphi) = \frac{\tau}{1-e^{i\varphi}(1-\tau)}$  where  $\tau$  is the transmissivity of the two beam splitters (left and right) coupling the cavity to the external modes, and  $\varphi$  is its internal phase shift. The probability that a photon crosses the cavity from left to right is given by  $p = \langle b_r^\dagger b_r \rangle$ , where initially only the mode  $a_l$  is populated (with a single photon). Using

Eq. (2), we find

$$p = |\sigma(\varphi)|^2 = \frac{\tau^2}{(1-\tau)^2 - 2(1-\tau)\cos(\varphi) + 1}. \quad (3)$$

By simply decreasing  $\tau$ , the transmissivity peaks of Eq. (3) can be narrowed at will, thus increasing the phase selectivity of the cavity. The width of the peaks can be calculated by imposing  $|\sigma(\varphi)|^2 = 1/2$ , which has solution  $\varphi = \arccos\left(1 - \frac{\tau^2}{2(1-\tau)}\right) \simeq \tau$ . Hence, in order to get a phase selectivity of the order of  $\pi/2^n$ , we need an exponentially small transmissivity  $\tau \simeq 2^{-n}$  in the cavity's beam splitters.

- [21] A. Wallraff, D. I. Schuster, A. Blais, L. Frunzio, R.-S. Huang, J. Majer, S. Kumar, S. M. Girvin and R. J. Schoelkopf, *Nature* **431**, 162 (2004); D. I. Schuster, A. A. Houck, J. A. Schreier, A. Wallraff, J. M. Gambetta, A. Blais, L. Frunzio, J. Majer, B. Johnson, M. H. Devoret, S. M. Girvin, and R. J. Schoelkopf, *Nature* **445**, 515 (2007).
- [22] A. Blais, J. Gambetta, A. Wallraff, D. I. Schuster, S. M. Girvin, M. H. Devoret, R. J. Schoelkopf, Eprint cond-mat/0612038, submitted to *Phys. Rev. A* (2006).
- [23] A. Blais, A. Maassen van den Brink, A.M. Zagorskin *Phys. Rev. Lett.* **90**, 127901 (2003).
- [24] P. Bertet, C. J. P. M. Harmans, J. E. Mooij, *Phys. Rev. B* **73**, 064512 (2006).
- [25] A.O. Niskanen, Y. Nakamura, J.-S. Tsai, *Phys. Rev. B* **73**, 094506 (2006).
- [26] C. W. Chou, H. de Riedmatten, D. Felinto, S. V. Polyakov, S. J. van Enk, and H. J. Kimble, *Nature* **438**, 828 (2005).
- [27] J. F. Sherson, H. Krauter, R. K. Olsson, B. Julsgaard, K. Hammerer, I. Cirac and E. S. Polzik, *Nature* **443**, 557-560 (2006).
- [28] M. Ley and R. Loudon, *J. Mod. Opt.* **34**, 227 (1987).

