

On relativistic elements of reality

Louis Marchildon

Département de physique, Université du Québec,
Trois-Rivières, Qc. Canada G9A 5H7
email: marchild@uqtr.ca

Abstract

Several arguments have been proposed some years ago, attempting to prove the impossibility of defining Lorentz-invariant elements of reality. I find that a sufficient condition for the existence of elements of reality, introduced in these proofs, seems to be used also as a necessary condition. I argue that Lorentz-invariant elements of reality can be defined but, as Vaidman pointed out, they won't satisfy the so-called product rule. In so doing I obtain algebraic constraints on elements of reality associated with a maximal set of commuting Hermitian operators.

1 Introduction

The notion of “element of reality” was introduced in the famous Einstein, Podolsky and Rosen (EPR) paper [1], as an attribute of a physical quantity whose value can be predicted with certainty without disturbing the system. Criticizing the EPR conclusion that quantum mechanics is incomplete, Bohr [2] argued that the phrase “without in any way disturbing a system” is ambiguous and emphasized the necessity of taking into account the experimental arrangement with which a physical quantity is measured. To avoid the ambiguity, Redhead [3] gave the following sufficient condition for the existence of an element of reality, hereafter called ER1:

If we can predict with certainty, or at any rate with probability one, the result of measuring a physical quantity at time t , then at the time t there exists an element of reality corresponding to

the physical quantity and having a value equal to the predicted measurement result. **[ER1]**

A number of interpretations of quantum mechanics involving various kinds of elements of reality were proposed after the EPR paper, in particular Bohmian mechanics [4] and modal interpretations [5]. These were originally developed as nonrelativistic theories, and it has been notoriously difficult to reconcile them with the special theory of relativity. Eventually, the question was raised whether Lorentz-invariant elements of reality are inconsistent with quantum mechanics [6, 7, 8].

The purpose of this paper is to revisit that question, and bring a number of additional considerations to it. I will first analyze in detail Hardy's argument, which was meant to show that Lorentz-invariant elements of reality are indeed inconsistent with quantum mechanics.¹ I will argue that this and related arguments use ER1 not only as a sufficient condition for the existence of an element of reality, but also, it seems, as a necessary condition. A contradiction then immediately follows, quite independently from details of quantum mechanics. My argument will make use of constraints, derived in the appendix, on elements of reality associated with a maximal set of commuting Hermitian operators. I will then investigate to what extent the light cone associated with an event can be used to define Lorentz-invariant elements of reality. It turns out to be possible, but these elements of reality won't satisfy the so-called product rule, i.e. an element of reality associated with a product of two commuting operators will not always be equal to the product of elements of reality associated with each operator [9, 10]. Building on this I will discuss a number of analyses of Hardy's and related arguments published in the literature.

2 Hardy's argument

Hardy's gedanken experiment [6] is illustrated in Fig. 1. Two Mach-Zehnder-type interferometers are set up, one for electrons (MZ^- , lower right) and one for positrons (MZ^+ , upper left). Electrons (positrons) are emitted with initial

¹Hardy's paper also provides a very interesting proof of Bell's theorem that does not make use of inequalities. That part of the paper will not be discussed here.

wave function s^- (s^+). Two beam splitters $BS1^\pm$ act in such a way that

$$|s^\pm\rangle \rightarrow \frac{1}{\sqrt{2}}(i|u^\pm\rangle + |v^\pm\rangle). \quad (1)$$

The overlap of the two interferometers allows paths u^- and u^+ to meet at point P . In that case the electron and positron annihilate, i.e.

$$|u^+\rangle|u^-\rangle \rightarrow |\gamma\rangle. \quad (2)$$

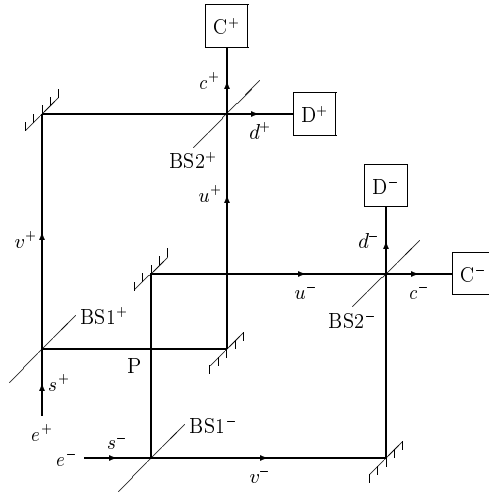

Figure 1: Hardy's thought experiment with two Mach-Zehnder-type interferometers

Let the initial state of the system be $|s^+\rangle|s^-\rangle$. Using (1) and (2), we find that beyond beam splitters $BS1^\pm$ and beyond point P , the state of the system has been transformed into

$$\frac{1}{2}(-\gamma + i|u^+\rangle|v^-\rangle + i|v^+\rangle|u^-\rangle + |v^+\rangle|v^-\rangle). \quad (3)$$

In each interferometer, the two paths are reflected by mirrors arranged so that the paths eventually meet again. At the meeting points are two additional beam splitters $BS2^-$ and $BS2^+$ that act on the incoming beams

so that²

$$|u^\pm\rangle \rightarrow \frac{1}{\sqrt{2}}(|c^\pm\rangle + i|d^\pm\rangle) \quad \text{and} \quad |v^\pm\rangle \rightarrow \frac{1}{\sqrt{2}}(i|c^\pm\rangle + |d^\pm\rangle). \quad (4)$$

Let F be the rest frame of the two interferometers. We assume that in F , the electron and positron in each run of the experiment reach BS2^- and BS2^+ simultaneously. Just before this then, the state of the system is given by (3). We now consider two additional Lorentz frames F^- and F^+ , moving with respect to F with opposite velocities. These velocities are chosen so that in F^- , the electron arrives at BS2^- much before the positron arrives at BS2^+ , whereas in F^+ , the positron arrives much before the electron. Consider a time in F^- when the electron has gone through BS2^- , but the positron has not yet reached BS2^+ . Using (3) and (4), we find that the state of the system is then given by

$$\frac{1}{2\sqrt{2}}(-\sqrt{2}\gamma - |u^+\rangle|c^-\rangle + 2i|v^+\rangle|c^-\rangle + i|u^+\rangle|d^-\rangle). \quad (5)$$

Similarly, at a time in F^+ when the positron has gone through BS2^+ but the electron has not yet reached BS2^- , the state of the system is given by

$$\frac{1}{2\sqrt{2}}(-\sqrt{2}\gamma - |c^+\rangle|u^-\rangle + 2i|c^+\rangle|v^-\rangle + i|d^+\rangle|u^-\rangle). \quad (6)$$

Finally, we note that when both the electron and positron have gone through the second beam splitters, the state of the system is given by

$$\frac{1}{4}(-2\gamma - 3|c^+\rangle|c^-\rangle + i|c^+\rangle|d^-\rangle + i|d^+\rangle|c^-\rangle - |d^+\rangle|d^-\rangle). \quad (7)$$

To argue against relativistic elements of reality, Hardy proposes a sufficient condition for their existence and a necessary condition for their Lorentz invariance. The sufficient condition for the existence of an element of reality essentially coincides with Redhead's ER1. The necessary condition for Lorentz invariance of elements of reality, hereafter called LI1, simply reads as:

The value of an element of reality corresponding to a Lorentz-invariant observable is itself Lorentz invariant. **[LI1]**

²In Ref. [6], beam splitters BS2^- and BS2^+ are removable, but we don't need this flexibility here.

I shall denote an element of reality associated with an observable A by $f(A)$. Whenever ER1 is satisfied for A , then $f(A)$ coincides with an eigenvalue of A , a real number.

Hardy introduces two observables U^\pm defined as

$$U^\pm = |u^\pm\rangle\langle u^\pm|. \quad (8)$$

He then points out that

1. in state $|u^+\rangle$, $f(U^+) = 1$;
2. in state $|u^-\rangle$, $f(U^-) = 1$;
3. in state $|u^+\rangle|u^-\rangle$, $f(U^+U^-) = 1$;
4. in any state $|u^+, u^-\rangle_\perp$ orthogonal to $|u^+\rangle|u^-\rangle$, $f(U^+U^-) = 0$.

From ER1 he concludes that

$$f(U^+)f(U^-) = 1 \Rightarrow f(U^+U^-) = 1. \quad (9)$$

We can now state Hardy's argument against Lorentz-invariant elements of reality. Consider a situation where, in frame F^+ , a positron is detected in D^+ before the electron reaches BS2⁻. Then the system's state (6) is projected onto its last term, and the electron's state becomes $|u^-\rangle$. In this case $f(U^-) = 1$ in F^+ and, by LI1 and since U^- is Lorentz invariant, $f(U^-) = 1$ in all Lorentz frames. Similarly, consider a situation where, in frame F^- , an electron is detected in D^- before the positron reaches BS2⁺. Then the system's state (5) is projected onto its last term, the positron's state becomes $|u^+\rangle$ and $f(U^+) = 1$ in all Lorentz frames. According to (7), both these situations will occur together, on average, in one of every sixteen runs. Whenever they occur together, in all frames before detection we have $f(U^-) = 1$ and $f(U^+) = 1$, whence by (9), $f(U^+U^-) = 1$. But according to (3) the state in F , the rest frame of the two interferometers, is orthogonal to $|u^+\rangle|u^-\rangle$. Hence $f(U^+U^-) = 0$, which establishes the contradiction and shows that Lorentz-invariant elements of reality are incompatible with quantum mechanics.

3 Analysis of the argument

In formulating his argument, Hardy made explicit use of the projection postulate. One can see, however, that this amounts to little more than a verbal

simplification, and that the use of the postulate is in no way necessary to reach the intended conclusion. Indeed consider the steps leading to the conclusion that $f(U^-) = 1$ in F^+ . From (6), one easily sees that the probability of obtaining the result 1 upon measuring U^- , conditional on obtaining the result 1 upon measuring D^+ , is given by

$$P(U^- \rightarrow 1 | D^+ \rightarrow 1) = \frac{P(U^- \rightarrow 1 \text{ and } D^+ \rightarrow 1)}{P(D^+ \rightarrow 1)} = \frac{|i/(2\sqrt{2})|^2}{|i/(2\sqrt{2})|^2} = 1. \quad (10)$$

This means that if we obtain 1 upon measuring D^+ , we can predict with certainty that we will obtain 1 upon measuring U^- . By ER1 then, and without any appeal to the projection postulate, $f(U^-) = 1$.

Let us now focus on condition ER1. Just like Redhead, Hardy intends it as a sufficient condition for the existence of an element of reality. I will now argue that it is actually used in a much stronger way. To see this, consider the following steps of a possible proof of (9):

1. Assume that $f(U^+)f(U^-) = 1$. Since $f(U^\pm)$ is either 1 or 0, we must have both $f(U^+) = 1$ and $f(U^-) = 1$.
2. Since there is an element of reality corresponding to U^+ having value 1, we can predict with certainty that measuring U^+ will yield value 1. Therefore the system's state $|\Phi\rangle$ is an eigenstate of U^+ with eigenvalue 1. Similarly, $|\Phi\rangle$ is an eigenstate of U^- with eigenvalue 1.
3. Since $|\Phi\rangle$ is an eigenstate of U^+ and U^- with eigenvalue 1 in each case, it is also an eigenstate of U^+U^- with eigenvalue 1.
4. Since $|\Phi\rangle$ is an eigenstate of U^+U^- with eigenvalue 1, we can predict with certainty that measuring U^+U^- will yield value 1. Hence $f(U^+U^-) = 1$.

Looking closely at step 2, one can see that it assumes that ER1 is not only a sufficient, but also a necessary condition. Admittedly, steps 1–4 represent one possible reconstruction of the proof of (9), and we cannot rule out other reconstructions that would use weaker conditions. But no proof of (9) is provided in Ref. [6] assuming ER1 as a sufficient condition only.

That ER1 is in fact used as a necessary condition gains additional support from the assumption that the elements of reality obey the so-called product rule, i.e.

$$f(U^+U^-) = f(U^+)f(U^-). \quad (11)$$

I show in the appendix that any real-valued function f which (i) is defined on a maximal set of commuting Hermitian operators, (ii) satisfies the product rule, and (iii) is 1 on some but not all unit projectors in the set, singles out a one-dimensional subspace of the state space, i.e. there is only one projector in the set on which $f = 1$. If the element of reality that this function assigns is identified with an eigenvalue of a quantum observable, then a unique state vector is singled out by the specification that $f = 1$. Hence it leads to the most definite predictions that quantum mechanics allows.

One should note that the same analysis applies to the proofs given in Ref. [7] and [8]. In [7], an inference similar to (9) is used at the bottom of the second column of p. 181. In [8], the authors consider separately the cases where QM is or is not complete. In the former (p. 124), elements of reality are taken to be eigenvalues, which necessarily satisfy the product rule. In the latter (p. 125), the product rule is explicitly assumed.

On reading Hardy's and related arguments, one may be tempted to question the appropriateness of conjoining a manifestly non-Lorentz-invariant sufficient condition for the existence of elements of reality (ER1) with a requirement of Lorentz invariance of some elements of reality (LI1). Assuming that ER1 is used not only as a sufficient but also as a necessary condition, the contradiction follows in a strikingly simple way: (a) For the experiment under consideration, the premise of ER1, as this condition is formulated, is true in some frames and not in others. (b) LI1 says that if the consequent of ER1 holds in one frame, then (for Lorentz-invariant observables) it holds in all frames. (c) But ER1 is also a necessary condition; therefore its premise must hold in all frames. We see that (c) plainly contradicts (a).

4 Lorentz-invariant elements

Condition ER1 involves the word “predict” in an essential way. In the technical context in which it is used here, just like in its normal usage, “predict” refers to the future. The premise of ER1 assumes that we know the (relevant) world configuration shortly before t in one Lorentz frame, and can infer from this the result of measuring the physical quantity A at time t .

Because ER1 refers to a specific Lorentz frame, it is clearly not a relativistically invariant criterion. Indeed in the Hardy setup, a prediction in frame F^+ can become a retrodiction in F^- , and vice versa. So how can we get an invariant criterion? The answer is that, instead of specifying a hy-

persurface in a noninvariant way (i.e. at constant time), we should use an invariant specification. The way to do this is to make use of the light cone whose apex coincides with the measurement event.³ The light cone, however, can be used in a number of different ways, which will have to be investigated more closely.

Suppose we use the backward light cone of the measurement event. A sufficient criterion for the existence of an element of reality could then be the following:

If from the (relevant) information on or inside the backward light cone of a possible measurement event \mathcal{E} , we can infer with certainty, or at any rate with probability one, the result of measuring a physical quantity at \mathcal{E} , then at that event there exists an element of reality corresponding to the physical quantity and having a value equal to the predicted measurement result. [**ER2**]

Formulated in this way, ER2 is a perfectly valid and relativistically invariant criterion. It is, however, completely inadequate as a specification of elements of reality in the sense of EPR. Indeed ER2 can only serve to specify elements of reality in the absolute future of the agent making the inference. But EPR had in mind elements of reality whose values could, in some circumstances at least, be inferred at events spacelike separated from the agent.

So instead of using the backward light cone, we should make use of the forward one. Here then is an appropriate sufficient criterion for the existence of an element of reality:

If from the (relevant) information on or outside the forward light cone of a possible measurement event \mathcal{E} , we can infer with certainty, or at any rate with probability one, the result of measuring a physical quantity at \mathcal{E} , then at that event there exists an element of reality corresponding to the physical quantity and having a value equal to the predicted measurement result. [**ER3**]

We should note that the word “infer” here can cover both prediction and retrodiction. In ER2, it covers only prediction. Readers who are familiar with the Hellwig-Kraus theory of state vector collapse [11] will probably see the

³Of course a measurement does not occur at a specific space-time point, but I will assume that the argument can be adapted to a more realistic situation.

analogy between that theory and ER3. In the Hellwig-Kraus approach, the collapse of the state vector occurs on the past light cone of the measurement event (say \mathcal{M}), instead of on an equal time hypersurface. Such a collapse can therefore be relevant to the attribution of an element of reality to a physical quantity at an event \mathcal{E} that is spacelike separated from (and in the relative past of) the collapse triggering event \mathcal{M} . I shall come back to the Hellwig-Kraus approach in Sec. 5, and argue that it stands in spite of objections made to it in the literature.

But we are not yet over. ER3 is a suitable condition for the existence of an element of reality pertaining to a local physical quantity. We still have to adapt it to nonlocal quantities, like U^+U^- in Hardy's setup. There are several obvious invariant ways to combine two light cones, through their union and their intersection. These operations are illustrated in Fig. 2, for one space and one time dimension. We shall denote by \mathcal{U} the union of the regions outside the forward light cones of the boxes associated with U^+ and U^- . Specifically, \mathcal{U} contains regions 1, 3 and 4 in Fig. 2. Likewise we shall denote by \mathcal{I} the intersection of the regions outside the forward light cones of the boxes. \mathcal{I} coincides with region 4 in Fig. 2.

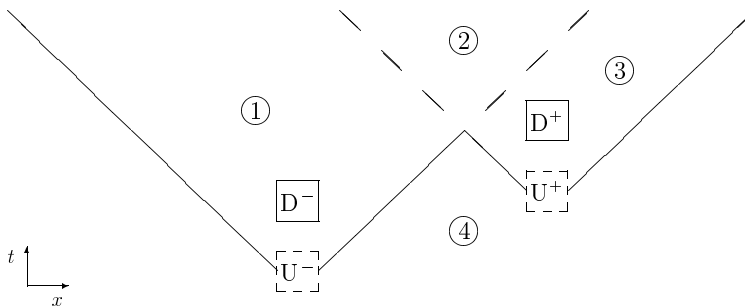

Figure 2: Combination of two light cones

Suppose that we try to adapt criterion ER3 to \mathcal{U} . It is clear that any time an actual measurement of U^+U^- is performed, its result can be deduced from information available in \mathcal{U} , for this region includes part of the absolute future of the measurement events. Hence the criterion is in this case trivial. I shall come back in Sec. 5 to the case where, as in Hardy's argument, no actual measurement of U^+U^- is performed.

Suppose next that we try to adapt criterion ER3 to \mathcal{I} . Let us see what we can say about elements of reality pertaining to the physical quantities

U^+ , U^- and U^+U^- in a run where detection occurs at D^+ and D^- . Since D^- is outside the forward light cone of U^+ , ER3 implies that $f(U^+) = 1$. Likewise since D^+ is outside the forward light cone of U^- , ER3 implies that $f(U^-) = 1$. This holds in all Lorentz frames.

It turns out, however, that neither D^+ nor D^- are in \mathcal{I} , the intersection of the regions outside the two forward light cones. Hence ER3 cannot be used to deduce the existence of an element of reality associated with U^+U^- , nor *a fortiori* to attribute a value to $f(U^+U^-)$. Hardy's argument therefore no longer goes through.

Thus if we pick \mathcal{I} (i.e. region 4) as the relevant region for inferring elements of reality like $f(U^+U^-)$, we have $f(U^+) = 1 = f(U^-)$ but the value of $f(U^+U^-)$ cannot be inferred. It therefore follows that the product rule (11) no longer necessarily holds. This is the price we have to pay for this notion of relativistically invariant elements of reality.

5 Discussion

Hardy's and related arguments were criticized by various authors, from several different angles. I will here review these criticisms in the light of the present analysis.

In a detailed analysis of Hardy's argument, Clifton and Niemann [7] suggested that the Lorentz-invariance criterion LI1 is too strong. They proposed instead the following:

If an element-of-reality corresponding to some Lorentz invariant physical quantity exists and has a value within a spacetime region R with respect to one spacelike hyperplane containing R then, *if it exists with respect to another hyperplane H containing R* , it has the same value in R with respect to H . [LI2]

Using LI2 instead of LI1, one easily sees that Hardy's argument no longer goes through. If, however, the objective is to have a Lorentz-invariant theory at the level of elements of reality, then LI2 will not meet it. For LI2 suggests that we will have elements of reality corresponding to Lorentz-invariant physical quantities that will exist in some Lorentz frames and not in others.

Another criticism of the argument, made in Refs. [7] and [12], is that elements of reality are defined without sufficiently taking context into account.⁴

⁴Replying to [12], Hardy [13] conceded that if one does not assume locality, his argument

It is well known that in theories involving hidden variables, their values depend on context, for instance on what specific observable is being measured far away. In Hardy’s setup, one can measure different observables related to the positron and the electron, by removing the mirrors $BS2^+$ and $BS2^-$. However, Cohen and Hiley [14] pointed out that to carry out the argument, Hardy only uses a single experimental context, the one where both mirrors are in place and both detectors D^+ and D^- fire. Thus context dependence construed as above is not relevant to the analysis. On the other hand, the criterion ER3 for the existence of elements of reality, and its generalization to nonlocal observables through the region \mathcal{I} introduced in Sec. 4, do in a quite specific sense involve context. Indeed the “relevant information” is not the same for the local observable U^+ as it is for the nonlocal observable U^+U^- . The expression “context dependence” may therefore remain more appropriate than the expression “observer specific” suggested in [14].

Cohen and Hiley have also argued that the use of the projection postulate is the crux of the problem. In Sec. 3, however, we showed that although Hardy formulated his argument in the language of the projection postulate, it doesn’t really depend on it. By using a functional-based formalism for the description of the state of a quantum-mechanical system, Cohen and Hiley can provide a relativistically-covariant description of whatever collapses occur in the Hardy experiment. That formalism, however, doesn’t seem to allow for elements of reality to be introduced even when measurement results can be predicted with certainty.⁵

Vaidman [9, 10] has argued that insistence on the validity of the product rule (11), on which Hardy’s and other arguments are based, is what prevents defining Lorentz-invariant elements of reality. To show this, Vaidman applied the Aharonov-Bergmann-Lebowitz (ABL) rule to the setup. In its original formulation [17], the rule gives the probability $\text{Prob}(P_i \rightarrow 1|\phi, \psi)$ that, if a system is prepared in a state $|\phi\rangle$ and found in a final stage to be in a state $|\psi\rangle$, an intermediate measurement associated with a projector P_i will find

doesn’t hold. In so doing he seems to have viewed condition ER1 differently.

⁵Dewdney and Horton [15] have introduced Lorentz-invariant elements of reality associated with Bohmian trajectories, but their approach appears to involve significant constraints on the particles’ motion. A Lorentz-invariant realistic approach to quantum mechanics was also proposed by Tumulka [16] in the context of the Ghirardi-Rimini-Weber model of spontaneous collapse, again with restrictions on the particles’ interaction. Ref. [16] also provides a brief overview of the literature on relativistic models explaining quantum-mechanical probabilities.

the result 1:

$$\text{Prob}(P_i \rightarrow 1|\phi, \psi) = \frac{\text{Tr}(P_\psi P_i P_\phi P_i)}{\sum_j \text{Tr}(P_\psi P_j P_\phi P_j)}. \quad (12)$$

Here P_ϕ and P_ψ project on states $|\phi\rangle$ and $|\psi\rangle$. The sum in the denominator runs on a set of orthogonal projectors summing to the identity.⁶

Vaidman then shows that if $|\phi\rangle$ is the state given in (3) and $|\psi\rangle = |d^+d^-\rangle$ (i.e. the state obtained upon detection by D^+ and D^-), then there is unit probability for the following three intermediate results: (i) U^+ yields 1; (ii) U^- yields 1; and (iii) U^+U^- yields 0.

These probabilities are unobjectionable if the intermediate measurements are carried out. But in Hardy's experiment, they are not. However, Vaidman extrapolates the ABL rule to counterfactual situations. He proposes to attribute elements of reality to physical quantities whose values can be deduced with certainty, on the basis of a counterfactual use of the ABL rule. From the results given above, it is clear that these elements of reality do not satisfy the product rule.

Can functions defined on commuting Hermitian operators and not satisfying the product rule still be called elements of *reality*? This is a semantical question that I shall not address, but there is no doubt that, if anything, they make for a peculiar kind of reality. Cohen and Hiley [18] have argued that the violation of the product rule entails a meaning of *true* which “differs from its meaning in standard predictive quantum mechanics and in all other branches of physics.” But the difference may not be so drastic. A proposition p and its negation may both be true if they refer to different times, i.e. to different contexts. As we have seen above, elements of reality are in some sense context dependent. Note that an operational, albeit indirect, meaning to the violation of the product rule can in the present situation be provided by weak measurements [19].

Cohen and Hiley also objected to Vaidman's counterfactual use of the ABL rule, on the grounds that the observables involved do not form the basis of a consistent family of histories. It would seem, however, that this lack of a consistent family only prevents assigning to elements of reality values that can be revealed in and would be unaffected by an eventual measurement. Much of the debate on the counterfactual use of the ABL rule comes from

⁶If the system's Hamiltonian doesn't vanish between measurements, $|\phi\rangle$ must be evolved forwards to the time of the intermediate measurement and $|\psi\rangle$ must similarly be evolved backwards.

the failure to realize that a number of different assertions can be made about counterfactual measurement results that are all consistent with the formalism of quantum mechanics. I have argued elsewhere [20] that the counterfactual use of the ABL rule, in situations where it is allowed, is not a consequence of the formalism of quantum mechanics, but is part of its interpretation.

I should point out that Vaidman's analysis corresponds to the choice indicated in Sec. 4, where the value of the element of reality corresponding to the nonlocal observable U^+U^- could be deduced from information in the union \mathcal{U} of the regions outside the two forward light cones of the events. As he claims, it thus provides Lorentz-invariant elements of reality.

In closing this section, I would like to argue for the consistency of the Hellwig-Kraus relativistic theory of the projection postulate, against the criticism made to it by Aharonov and Albert [21].

Briefly, Aharonov and Albert correctly pointed out that some nonlocal observables can be measured by means of local measurements only. To illustrate this, they considered two spin 1/2 particles prepared in the singlet state and then separated at an arbitrarily large distance. Next they introduced two measurement apparatus, correlated in such a way that the difference of their (three-dimensional) positions and the sum of their momenta are well defined. They then showed that these apparatus can be used, say at $t = -\epsilon$ in some frame, to assert that each component of the two particles' total spin vanishes, in a non-demolition way.

Now suppose that at time t in that frame, the z -component of the spin of the left particle is measured. According to the Hellwig-Kraus theory, that particle's state then collapses onto $|+; \hat{z}\rangle$ or $|-; \hat{z}\rangle$ along the backward light cone of the particle. This, Aharonov and Albert maintain, contradicts the fact that the two-particle state is $|S = 0\rangle$ just before the measurement (at $t = -\epsilon$).

According to the Hellwig-Kraus theory, however, the local non-demolition measurements at $t = -\epsilon$ will not collapse the nonlocal state on this equal-time hypersurface (that would not be relativistically invariant), but on the union of the two particles' backward light cones. Hence the two-particle state $|S = 0\rangle$ will be valid in the region bounded by these light cones and the one coming from the measurement event of the z -spin of the left particle.

6 Conclusion

Hardy's and other proofs of the nonexistence of Lorentz-invariant elements of reality rely in one way or another on the assumption that the element of reality associated with a product of commuting Hermitian operators is the product of the elements of reality associated with each individual operator. This assumption, as shown in the appendix, constrains values of elements of reality defined on a maximal set of commuting Hermitian operators. Once it is removed, Lorentz-invariant elements of reality can be defined using various combinations of the light cones associated with measurement events. This construction, although not necessarily involving state vector collapse, is reminiscent of the Hellwig-Kraus theory. The kind of context dependence involved allows for the failure of the product rule and clarifies the sense in which these elements of reality differ from what this concept usually covers.

Acknowledgements

I am grateful to the Natural Science and Engineering Research Council of Canada for financial support. It is a pleasure to thank Simon Lévesque for discussions on a related topic which stimulated some of the thoughts presented here. My thanks also go to Andrew Laidlaw for comments, and to two anonymous referees for insightful remarks.

Appendix

In this section I address the question of finding real-valued functions, on a maximal set of commuting Hermitian operators, that satisfy the product rule.

Let \mathcal{V} be a complex vector space of finite dimension $N > 2$, and let $\{|u_i\rangle\}$ be an orthonormal basis in \mathcal{V} . Then the set of all operators of the form

$$H = \sum_{i=1}^N \lambda_i |u_i\rangle\langle u_i|, \quad (13)$$

with the λ_i real, is a maximal set of commuting Hermitian operators. We look for real functions $f(H)$ such that the product rule is satisfied, i.e.

$$f(H_a)f(H_b) = f(H_a H_b) \quad (14)$$

for any H_a and H_b having the form (13).

For any projector P , (14) implies that $f(P) = f(PP) = f(P)f(P)$, so that $f(P) = 0$ or 1 . Let P_i denote the one-dimensional projector $|u_i\rangle\langle u_i|$. All possible cases then fall into the following three disjoint collections:

1. $f(P_i) = 1$ for all P_i .
2. $f(P_i) = 1$ for some P_i and 0 for others.
3. $f(P_i) = 0$ for all P_i .

Let us now examine these possibilities in more detail.

Case 1 Let $K = P_i + \lambda_j P_j$ with $i \neq j$ and $\lambda_j \neq 0$. Then

$$f(K) = f(K)f(P_i) = f(KP_i) = f(P_i) = 1 \quad (15)$$

and

$$f(K) = f(K)f(P_j) = f(KP_j) = f(\lambda_j P_j), \quad (16)$$

whence $f(\lambda_j P_j) = 1$ for all j and $\lambda_j \neq 0$. For any nontrivial H as given in (13), there is a k such that $\lambda_k \neq 0$. But then

$$f(H) = f(H)f(P_k) = f(HP_k) = f(\lambda_k P_k) = 1. \quad (17)$$

Note that since $P_i P_j = 0$ we also have $f(0) = 1$, hence $f(H) = 1$ for all H .

Case 2 Here there has to be exactly one P_i such that $f(P_i) = 1$. For if $f(P_i) = 1 = f(P_j)$ with $i \neq j$, then

$$f(0) = f(P_i P_j) = f(P_i) f(P_j) = 1. \quad (18)$$

But if k is such that $f(P_k) = 0$,

$$f(0) = f(P_i P_k) = f(P_i) f(P_k) = 0, \quad (19)$$

which contradicts (18).

Now let H be as in (13). Then

$$f(H) = f(H)f(P_i) = f(HP_i) = f(\lambda_i P_i). \quad (20)$$

Moreover

$$f(\lambda_i P_i) f(\lambda'_i P_i) = f(\lambda_i \lambda'_i P_i). \quad (21)$$

Restricted to positive values of λ_i , (21) means that f is a one-dimensional representation of the Lie group of products of real numbers. In the exponential parametrization $\lambda = \exp(\ln \lambda)$, hence representations have the form $f(\lambda_i P_i) = \exp(\alpha \ln \lambda_i) = (\lambda_i)^\alpha$, where α must be real for f to be. To extend f to negative values of λ_i we can either put $f(-|\lambda_i| P_i) = |\lambda_i|^\alpha$ for all λ_i or $f(-|\lambda_i| P_i) = -|\lambda_i|^\alpha$ for all λ_i . Finally, for f to remain finite as $\lambda_i \rightarrow 0$, the exponent α must be nonnegative. This also follows from (19) if f is required to be continuous. It then follows from (20) that for all H

$$f(H) = |\lambda_i|^\alpha \quad (22)$$

or

$$f(H) = \begin{cases} (\lambda_i)^\alpha & \text{if } \lambda_i \geq 0, \\ -|\lambda_i|^\alpha & \text{if } \lambda_i < 0. \end{cases} \quad (23)$$

Case 3 We see at once that $f(0) = 0$. It may be that there is a two-dimensional projector $P_{ij} = P_i + P_j$ such that $f(P_{ij}) = 1$. Then for any projector which is a sum of one or several P_k orthogonal to P_{ij} ,

$$f(P) = f(P_{ij}) f(P) = f(P_{ij} P) = f(0) = 0 \quad (24)$$

and

$$f(P + P_i) = f(P + P_i) f(P_{ij}) = f[(P + P_i) P_{ij}] = f(P_i) = 0. \quad (25)$$

Likewise we easily see that $f(P + P_j) = 0$ and $f(P + P_{ij}) = 1$. If we let $f(H) = |\lambda_i|^\alpha |\lambda_j|^\beta$ for $\alpha > 0$ and $\beta > 0$, we find at once that (14) is satisfied for all H_a and H_b . It can also be satisfied with various choices similar to (23).

If there is no two-dimensional projector P_{ij} such that $f(P_{ij}) = 1$ (and therefore $f(P_{ij}) = 0$ for all i and j), it may be that there is a three-dimensional projector $P_{ijk} = P_i + P_j + P_k$ such that $f(P_{ijk}) = 1$. Letting $f(H) = |\lambda_i|^\alpha |\lambda_j|^\beta |\lambda_k|^\gamma$ (with $\alpha > 0$, $\beta > 0$ and $\gamma > 0$), we see that (14) is satisfied for all H_a and H_b . The same argument goes on in higher dimensions. It is tempting to conjecture that this exhausts all possibilities, but I do not have a proof of this general statement.

References

- [1] A. Einstein, B. Podolsky and N. Rosen, “Can quantum-mechanical description of physical reality be considered complete?” *Phys. Rev.* **47**, 777–80 (1935).
- [2] N. Bohr, “Can quantum-mechanical description of physical reality be considered complete?” *Phys. Rev.* **48**, 696–702 (1935).
- [3] M. Redhead, *Incompleteness, Nonlocality, and Realism* (Clarendon Press, Oxford, 1987).
- [4] D. Bohm, “A suggested interpretation of the quantum theory in terms of ‘hidden’ variables (I and II),” *Phys. Rev.* **85**, 166–93 (1952).
- [5] P. E. Vermaas, *A Philosopher’s Understanding of Quantum Mechanics. Possibilities and Impossibilities of a Modal Interpretation* (Cambridge University Press, Cambridge, 1999).
- [6] L. Hardy, “Quantum mechanics, local realistic theories, and Lorentz-invariant realistic theories,” *Phys. Rev. Lett.* **68**, 2981–4 (1992).
- [7] R. Clifton and P. Niemann, “Locality, Lorentz invariance, and linear algebra: Hardy’s theorem for two entangled spin- s particles,” *Phys. Lett. A* **166**, 177–84 (1992).
- [8] R. Clifton, C. Pagonis and I. Pitowsky, “Relativity, quantum mechanics and EPR,” *Proc. of the Biennial Meeting of the PSA*, Vol. 1 (Philosophy of Science Association, 1992), pp. 114–28.
- [9] L. Vaidman, “Lorentz-invariant ‘elements of reality’ and the joint measurability of commuting observables,” *Phys. Rev. Lett.* **70**, 3369–72 (1993).
- [10] L. Vaidman, “The analysis of Hardy’s experiment revisited,” quant-ph/ 9703018.
- [11] K. E. Hellwig and K. Kraus, “Formal description of measurements in local quantum field theory,” *Phys. Rev. D* **1**, 566–71 (1970).

- [12] K. Berndl and S. Goldstein, “Comment on ‘Quantum mechanics, local realistic theories, and Lorentz-invariant realistic theories’,” *Phys. Rev. Lett.* **72**, 780 (1994).
- [13] L. Hardy, “Hardy replies,” *Phys. Rev. Lett.* **72**, 781 (1994).
- [14] O. Cohen and B. J. Hiley, “Reexamining the assumption that elements of reality can be Lorentz invariant,” *Phys. Rev. A* **52**, 76–81 (1995).
- [15] C. Dewdney and G. Horton, “Relativistically-invariant extension of the de Broglie-Bohm theory of quantum mechanics,” *J. Phys. A* **35**, 10117–27 (2002).
- [16] R. Tumulka, “A relativistic version of the Ghirardi-Rimini-Weber model,” *J. Stat. Phys.* **125**, 825–844 (2006).
- [17] Y. Aharonov, P. G. Bergmann and J. L. Lebowitz, “Time symmetry in the quantum process of measurement,” *Phys. Rev.* **134**, B1410–16 (1964).
- [18] O. Cohen and B. J. Hiley, “Elements of reality, Lorentz invariance, and the product rule,” *Found. Phys.* **26**, 1–15 (1996).
- [19] Y. Aharonov, A. Botero, S. Popescu, B. Reznik and J. Tollaksen, “Revisiting Hardy’s paradox: counterfactual statements, real measurements, entanglement and weak values,” *Phys. Lett. A* **301**, 130–38 (2002).
- [20] L. Marchildon, “The counterfactual meaning of the ABL rule,” *Proc. of the International Conference on Quantum Theory: Reconsideration of Foundations—2*, A. Khrennikov, Ed., (Växjö University Press, 2004), pp. 403–12 [also available as quant-ph/0307082].
- [21] Y. Aharonov and D. Z. Albert, “Can we make sense out of the measurement process in relativistic quantum mechanics?” *Phys. Rev. D* **24**, 359–70 (1981).