

# Experimental interference of independent photons

Rainer Kaltenbaek and Bibiane Blauensteiner

*Institute for Experimental Physics, University of Vienna, Boltzmannngasse 5, A-1090 Vienna, Austria*

Marek Żukowski

*Institute for Experimental Physics, University of Vienna, Boltzmannngasse 5, A-1090 Vienna, Austria and  
University of Gdansk, Institute of Theoretical Physics and Astrophysics, Wita Stwosza 57, PL-08-952 Gdansk, Poland*

Markus Aspelmeyer and Anton Zeilinger

*Institute for Experimental Physics, University of Vienna, Boltzmannngasse 5, A-1090 Vienna, Austria and  
Institute for Quantum Optics and Quantum Information (IQOQI),  
Austrian Academy of Sciences, Boltzmannngasse 3, A-1090 Vienna, Austria*

Interference of photons emerging from independent sources is essential for modern quantum information processing schemes, above all quantum repeaters and linear-optics quantum computers. We report an observation of non-classical interference of two single photons originating from two independent, separated sources, which were actively synchronized with an r.m.s. timing jitter of 260 fs. The resulting (two-photon) interference visibility was  $83 \pm 4$  %.

Is it possible to observe fully destructive interference of photons if they all originate from separate, independent sources? Yes, according to quantum theory [1, 2, 3]. The perfect interference of photons emerging from independent sources cannot be understood by the classical concept of the superposition of electromagnetic fields but only by the interference of probability amplitudes of multi-particle detection events. As stressed by Mandel “this prediction has no classical analogue, and its confirmation would represent an interesting test of the quantum theory of the electromagnetic field” [2].

Mastering the techniques involving independent sources of single photons and entangled pairs of photons has become vital for implementations of quantum networks and quantum computing schemes [4, 5]. For these devices to work it is often tacitly assumed that stable interference between systems from independent sources is feasible. The generic example is that of quantum repeaters [6], which by definition involve entanglement swapping and distillation between spatially separated, independent nodes requiring independent sources. Teleportation of states of particles emitted by sources completely detached from the sources of the entangled pairs of the quantum channel could become feasible. Other applications are linear optics quantum computing schemes of the KLM-type [7], in which ancilla qubits need to become entangled to other, independent optical qubits during the process of the computation.

To demonstrate that two independently emitted photons do interfere, it is important to assure that there exists no possibility whatsoever for the coherence properties of the light emitted by either source to be influenced by the other. Therefore, the operation of one source must not in any way rely on the working of the other source. Such a configuration addresses exactly the needs for practical quantum communication and computation schemes. In the case of long-distance quantum

communication any common optical elements shared by the sources and thus any dependence would impede the working of the scheme over large distances due to dispersion or losses. Our experiment fulfills these requirements for independent quantum sources. At the same time it serves as a prototype solution for a variety of quantum information processing devices.

First, consider two independent classical sources. Any correlation between intensities at two detectors placed in the joint far-field of the sources is a manifestation of standard interference of classical waves and shows at most 50 % visibility [3]. This is only observable if the detector integration times are below the coherence times of the two fields. A well-known example is the stellar interferometry method introduced by Hanbury-Brown and Twiss [8].

The situation becomes fundamentally different for quantum states of light, e.g. in the case of two separate spontaneously decaying atoms. While one photon can be detected practically anywhere, there are points for which detection of the second photon is then strictly forbidden. The resulting correlation pattern has 100% visibility, completely unexplainable by interference of classical waves. This is due to destructive interference of two indistinguishable processes: (a) the photon registered in the first detector came from source 1 and the photon registered in the second detector from source 2, and (b) the photon registered in the first detector came from source 2 and the photon registered in the second detector from source 1.

Quantum interference of two fully independent photons has thus far never been observed. Since the 1960s, however, interference of light from independent sources has been addressed in many experiments. In [9] two independent He-Ne lasers were used to observe the beating of their superposed outputs. Later [10], transient spatial interference fringes between beams from indepen-

dent ruby lasers were reported. In both cases the interference was classically explainable. Partly motivated by the often overinterpreted quotation from Dirac that each photon interferes only with itself [11], follow-up experiments [12, 13] investigated the question whether one can observe interference of two photons if each one was generated by a different source. This was done by simply attenuating the laser beams. However, attenuation does not affect the statistical nature of laser light. The only quantum aspect was that the detection involved clicks due to photon registrations. Consequently, the observed effects could “not readily be described in terms of one photon from one source interfering with one from the other” [12].

All following experiments involving the interference between single photons employed the well-known Hong-Ou-Mandel (HOM) interference effect, which utilizes the bosonic nature of photons: two indistinguishable photons that enter a 50:50 beam splitter via different input ports will always be detected in one output port. Such two-photon interference was first reported [14] for photon pairs emerging from a spontaneous parametric down-conversion (SPDC) source.

The first interference of separately generated photons was observed by Rarity et al. [15] (see also [16]). They measured Hong-Ou-Mandel-type (HOM) interference [14] of an SPDC photon and an attenuated part of the very same laser beam pumping the SPDC process. Further related experiments, provided gradual progress with respect to the independence of the utilized sources. A first step was the interference of two triggered single photons created via SPDC by the same pump pulse passing twice through the very same SPDC crystal [17]. Further contributions used photons generated by two mutually coherent time-separated pulses from the same mode-locked laser in one SPDC crystal [18] and, later, generated in one quantum dot [19]. Another step was to create interfering photons in two separate SPDC crystals pumped by the same laser [20]. The most recent experiment along that line used pulses from two intersecting laser cavities sharing the same Kerr medium [21].

However, as has been pointed out in one of those prior works, “truly independent sources require the use of independent but synchronized fs laser[s]” [20]. Our experiment employs this technique and realizes a scheme involving two independent quantum sources which can in principle be separated by large distances.

The photons emitted from a quantum source are typically generated by the interaction of an (optical) pump field with a nonlinear medium. The medium and the pump field are integral constituents of the source. In our experiment, each of the two sources consists of an SPDC crystal pumped optically by a pulsed fs laser.

To be able to observe interference we have to make sure that the two photons registered behind the beam splitter cannot be distinguished in any way. We use SPDC

to generate pairs of correlated photons. The detection event of one of the photons (trigger) of each pair is used to operationally define the presence of the other one on its way to the beam splitter (in this way we assure that the observed interference is due to two photons only, each from a different source). In such a case without frequency filtering, the initial sharp time correlation of photons of an SPDC pair poses a problem: the times of registration of the trigger photons provide temporal distinguishability of the photon registrations behind the beam splitter. Short pump pulses and spectral filters narrower than the bandwidth of these pulses in the paths of the photons give the desired indistinguishability [22].

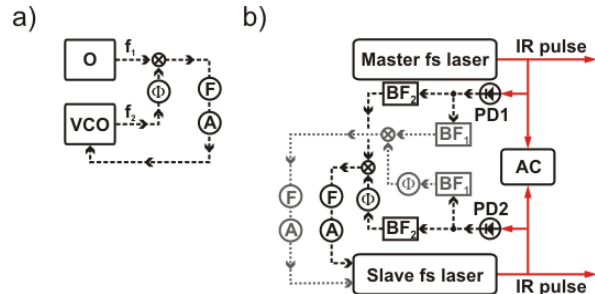

FIG. 1: (a) A phase-locked loop (PLL) synchronizes a voltage controlled oscillator (VCO) relative to another oscillator (O). The frequency of the VCO is adjusted by the feedback signal of a phase detector ( $\otimes$ ), which is fed through a low-pass filter (F) and an amplifier (A) (see e.g., [23]). (b) The pump lasers are time-synchronized by a Coherent Synchrolock<sup>TM</sup> using two PLLs. One operates at the repetition frequency of the lasers (76 MHz) for a coarse time-synchronization. Then, this PLL is switched off and the second PLL operating at the lasers’ 9<sup>th</sup> harmonic (684 MHz) takes over. Both PLLs adjust the “slave” laser’s repetition frequency via cavity mirrors driven by piezo actuators. The PLLs are fed by fast photo diodes ( $PD_1$  and  $PD_2$ ) filtered by bandwidth filters ( $BF_1$  and  $BF_2$ ) to get the fundamental and 9<sup>th</sup> harmonic signals. The performance of the synchronization is observed via an autocorrelator (AC).

Additional timing information is contained in the time difference between the independent pulses pumping the two SPDC crystals. In principle, one could compensate this again by filtering. For pulses without any time correlation this would, however, require extremely narrow filters and eventually result in prohibitively low count rates. Synchronizing the pulses of the two independent pumps increases the probability of joint emission events (see fig. 1b) and hence the count rates. *The fact that one needs to actively synchronize the sources is a direct unavoidable consequence of their independence.* The active synchronization method we use involves only electronic communication (10 kHz bandwidth) about the relative pulse timing between the independently running femtosecond lasers (see fig. 1b). No optical elements whatsoever are shared by the pumps.

Our two SPDC crystals were pumped by UV pulses with centre wavelengths of  $394.25 \pm 0.20$  nm and  $394.25 \pm 0.20$  nm and r.m.s. bandwidths of  $0.7 \pm 0.1$  nm and  $0.9 \pm 0.1$  nm. These beams were produced via frequency doubling of IR pulses from two independent Ti:Sa femtosecond lasers (master and slave, see fig. 2). One of these mode-locked lasers was driven by an Ar-Ion gas laser, the other by a solid-state Nd:YAG laser. They produced pulses at approx. 76 MHz repetition rate with centre wavelengths of  $788.5 \pm 0.4$  nm and  $788.5 \pm 0.4$  nm, r.m.s. bandwidths of  $2.9 \pm 0.1$  nm and  $3.2 \pm 0.1$  nm and r.m.s. pulse widths of  $49.3 \pm 0.3$  fs and  $46.8 \pm 0.3$  fs. The laser pulses were synchronized via electronic feedback loops up to a relative timing jitter of  $260 \pm 30$  fs using the commercially available Synchrolock<sup>TM</sup> system from Coherent Inc. (see fig. 1b).

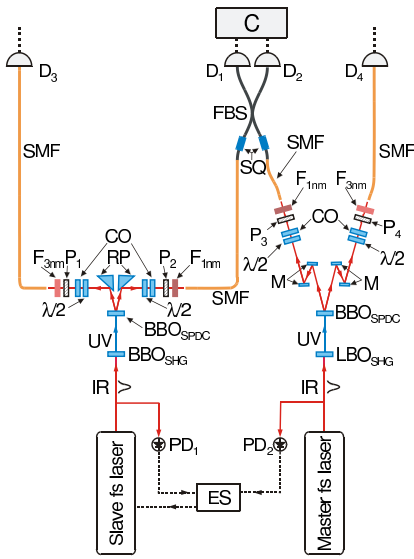

FIG. 2: Pulsed IR laser beams, which were electronically synchronized (ES, see fig. 1), were frequency-doubled (one in a Lithium-Triborate (LBO), the other in a  $\beta$ -Barium Borate (BBO) crystal). The resulting UV beams pumped type-II BBO-crystals for SPDC. Reflecting prisms (RP) and mirrors (M) guided the SPDC photons through half-wave plates and BBO crystals (CO) to compensate various walk-off effects. All photons were coupled into single mode fibers (SMF) to guarantee optimal spatial mode overlap. Polarizers  $P_1$ - $P_4$ , narrow bandwidth filters  $F_1$ - $F_4$  and fiber squeezers (SQ) ensured the indistinguishability of the photons at the single-mode fiber beamsplitter. Coincidences C between the detectors  $D_1$  and  $D_2$  could be triggered on detection events in both  $D_3$  and  $D_4$ .

To observe the interference of two independent photons, we varied the time delay between the two lasers in 300 fs steps with an accuracy better than 100 fs. The measurement time for each data point was 900 s. Long-time drifts of the relative delay between the lasers were compensated by measuring in blocks of 60 s and by automatic readjustment of the delay between these mea-

surement blocks. This was done by tuning the intensity of the light detected by one of the fast photo diodes used for synchronization, which introduces a small change of delay between the lasers, which was monitored via an autocorrelator (AC).

The interference, in the form of a Hong-Ou-Mandel dip, is shown in Figure 3a. The visibility of  $83 \pm 4$  % is well beyond the classical limit of 50% [3]. Both the observed visibility and the r.m.s. dip width of  $0.79 \pm 0.03$  ps agree well with the theoretically expected values of  $84 \pm 3$  % and  $0.86 \pm 0.07$  ps, given the relative pulse timing jitter and filter bandwidths (see Appendix). Our result therefore clearly agrees with the quantum predictions.

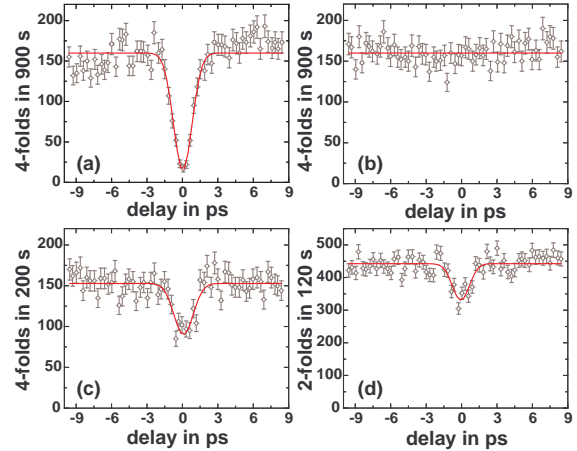

FIG. 3: Experimental two-photon interference from independent sources. (a) HOM-type interference of indistinguishable photons from actively synchronized independent sources. The observed visibility was  $83 \pm 4$  % and the dip width was  $0.79 \pm 0.04$  ps. (b) Input photons distinguishable by their polarization. No interference occurs. (c) Unpolarized input photons show limited interference due to partial distinguishability. The observed visibility was  $(26 \pm 3)$  %. (d) Classical interference from a thermal source, showing a dip visibility of  $15 \pm 2$  %.

To additionally demonstrate the role played by distinguishability in this effect we prepared different input states under otherwise equivalent experimental conditions. First, we used perfectly distinguishable orthogonally polarized input states, which as expected show no interference (Fig. 3b). Next, unpolarized input photons (Fig. 3c) were used which are a mixture of orthogonally polarized photons and hence are partially distinguishable. They still have a probability of  $\frac{1}{2}$  to coincide in their polarization, which results in an expected visibility of ideally 33 % or, taking into account the relative timing jitter,  $29.6 \pm 0.8$  %. We observed  $26 \pm 3$  %. Finally, we demonstrated the interference for photon sources endowed with thermal statistics. Without monitoring the trigger detection events, the emission statistics in each

input mode a and b of the beam splitter is equivalent to light emitted by a thermal source. For two such beams of equal average intensity one would expect 20 % visibility [3] in the ideal case or  $18.0 \pm 0.5$  % when bearing in mind the relative timing jitter. Experimentally we achieved a lower visibility of  $14.5 \pm 2.0$  % due to differences of the SPDC-pair rates in the two sources (approx. a factor of 2). Note, that for specially prepared classical light sources the visibility can even reach the very maximum of 50 % [3].

Our experiment demonstrates the feasibility of interference of two single photons originating from independent, spatially separated sources, which were actively time-synchronized. The visibility of the effect is above the threshold for further use in quantum communication processes like quantum teleportation or entanglement swapping. This result is a step towards the realization of quantum repeaters, quantum networks and certain optical quantum computing schemes. Due to the separation of the utilized sources the presented scheme opens the door for future long distance applications involving multi-photon interference. Moreover, the use of such independent sources might also provide conceptual advantages for experiments on the foundations of quantum physics [24].

We are grateful to Č. Brukner, A. Dominguez, Th. Jennewein, A. Poppe, K. Resch, P. Walther and G. Weihs for theoretical discussion and experimental advice. We acknowledge support from the Austrian Science Fund FWF (SFB F15), the DTO-funded U.S. Army Research Office Contract No. W911NF-05-0397 and the European Commission under projects RamboQ, SECOQC and QAP. MZ is supported by an FNP Professorial Subsidy and MNiI grant Nr. 1P03 04927. The collaboration is supported by the Austrian-Polish Collaboration Program öAD/MNiI.

## APPENDIX

To obtain the theoretical expectations for the HOM-dip via standard quantum electrodynamics. We assume both lasers to have an r.m.s. bandwidth of  $\sigma_p$ , both interfering photons to be filtered to an r.m.s. bandwidth  $\sigma_S$  and both trigger photons to  $\sigma_T$ . The timing jitter between the two generated SPDC pairs is given by  $\sigma_J = 350 \pm 30$  fs, resulting from the jitter of the laser synchronization ( $260 \pm 30$  fs gaussian jitter) and the group-velocity mismatch between UV and IR photons in the SHG and SPDC crystals. The central wavelengths of the lasers and the filters are assumed to be equal.

With these assumptions the visibility of the HOM dip is given by

$$2 \frac{\sigma_p}{\sqrt{\frac{(\sigma_S^2 + \sigma_p^2 + 2\sigma_p^2 \sigma_J^2 \sigma_S^2)(\sigma_p^2 + \sigma_T^2)}{\sigma_p^2 + \sigma_S^2 + \sigma_T^2}}} - \sigma_p, \quad (\text{A.1})$$

which reduces to the formula given in [22] for  $\sigma_J = 0$  and  $\sigma_T \rightarrow \infty$ .

By the same method the dip width is found to be

$$\frac{\sqrt{\sigma_p^2 + \sigma_S^2(1 + 2\sigma_J^2 \sigma_p^2)}}{\sqrt{2}\sigma_S \sigma_p}. \quad (\text{A.2})$$

A detailed derivation, also for more general cases, is given elsewhere [25].

- 
- [1] R. H. Dicke, in *Proceedings of the 3rd International Conference on Quantum Electronics*, edited by P. Grivet and N. Bloembergen (Dunod, Paris, and Columbia University Press, New York, 1964), p. 35.
  - [2] L. Mandel, Phys. Rev. A **28**, 929 (1983).
  - [3] H. Paul, Rev. Mod. Phys. **58**, 209 (1986).
  - [4] D. Bouwmeester, A. Ekert, and A. Zeilinger, *The Physics of Quantum Information* (Springer, Berlin, 2000).
  - [5] M. Nielsen and I. Chuang, *Quantum Computation and Quantum Information Theory* (Cambridge Univ. Press, Cambridge, 2000).
  - [6] H.-J. Briegel, W. Dür, J. I. Cirac, and P. Zoller, Phys. Rev. Lett. **81**, 5932 (1998).
  - [7] E. Knill, R. Laflamme, and G. Milburn, Nature **409**, 46 (2000).
  - [8] R. H. Brown and R. Q. Twiss, Nature **178**, 1046 (1956).
  - [9] A. Javan, E. A. Ballik, and W. L. Bond, J. Opt. Soc. Am. **52**, 96 (1962).
  - [10] G. Magyar and L. Mandel, Nature **198**, 255 (1963).
  - [11] P. A. M. Dirac, *The Principles of Quantum Mechanics* (Oxford University Press, London, 1958), p. 9, 4th ed.
  - [12] R. L. Pfeeger and L. Mandel, Phys. Rev. **159**, 1084 (1967).
  - [13] W. Radloff, Ann. Phys. (Leipzig) **26**, 178 (1971).
  - [14] C. K. Hong, Z. Y. Ou, and L. Mandel, Phys. Rev. Lett. **59**, 2044 (1987).
  - [15] J. G. Rarity, P. R. Tapster, and R. Loudon, in *Quantum Interferometry*, edited by F. D. Martini, G. Denardo, and Y. Shih (VCH, Weinheim, 1996), eprint quant-ph/9702032 (1997).
  - [16] A. Kuzmich, I. A. Walmsley, and L. Mandel, Phys. Rev. Lett. **85**, 1349 (2000).
  - [17] D. Bouwmeester, J.-W. Pan, K. Mattle, M. Eibl, H. Weinfurter, and A. Zeilinger, Nature **390**, 575 (1997).
  - [18] T. E. Keller, M. H. Rubin, and Y. Shih, Phys. Lett. A **244**, 507 (1998).
  - [19] C. Santori, D. Fattal, J. Vučković, G. S. Solomon, and Y. Yamamoto, Nature **419**, 594 (2002).
  - [20] H. de Riedmatten, I. Marcikic, W. Tittel, H. Zbinden, and N. Gisin, Phys. Rev. A **67**, 022301 (2003).
  - [21] T. Yang, Q. Zhang, T.-Y.-Chen, S. Lu, J. Yin, J.-W. Pan, Z.-Y. Wie, J.-R. Tian, and J. Zhang (2005), quant-ph/0502146.
  - [22] M. Żukowski, A. Zeilinger, and H. Weinfurter, Ann. N. Y. Acad. Sci. **755**, 91 (1995).
  - [23] P. Horowitz and W. Hill, *The Art of Electronics* (Cambridge University Press, 1989), 2nd ed.
  - [24] B. Yurke and D. Stoler, Phys. Rev. Lett. **68**, 1251 (1992).
  - [25] R. Kaltenbaek, Ph.D. thesis, University of Vienna (2006).