

Quantization of Games: Towards Quantum Artificial Intelligence

Katarzyna Miakisz

Institute of Mathematics, University of Białystok,
Akademicka 2, Pl 15267 Białystok, Poland
e-mail: kmiakisz@math.uwb.edu.pl

Edward W. Piotrowski

Institute of Mathematics, University of Białystok,
Lipowa 41, Pl 15424 Białystok, Poland
e-mail: ep@alpha.uwb.edu.pl

Jan Śladkowski

Institute of Physics, University of Silesia,
Uniwersytecka 4, Pl 40007 Katowice, Poland
e-mail: sladk@us.edu.pl

Abstract

On grounds of the discussed material, we reason about possible future development of quantum game theory and its impact on information processing and the emerging information society. The idea of quantum artificial intelligence is explained.

PACS Classification: 02.50.Le, 03.67.Lx, 05.50.+q, 05.30.d

Mathematics Subject Classification: 81-02, 91-02, 91A40, 81S99

Keywords and phrases: quantum games, quantum strategies, quantum information theory, quantum computations, artificial intelligence

1 Introduction

The construction of global information infrastructure caused one of the main paradigm shifts in human history: information is becoming a crucial if not the most important resource. The scientific community has realized that information processing is a physical phenomenon and that information theory is inseparable from both applied and fundamental physics. Investigation into the physical aspects of information processing opened new perspectives of computation, cryptography and communication methods. Very often quantum approach provides advantages over the classical setting. Often the problem can be perceived as game and there are examples illustrating methods of gaining an advantage over “classical opponents” by using quantum strategies [1]-[4]. Note that games against nature [5] and quantum evolutionary games [6] certainly include those for which nature is quantum mechanical. In these cases one can hardly speak about rational agents or players. Nevertheless, as we will show, sort of quantum artificial intelligence can be invoked here. In this paper we would like to convince the reader that the research on quantum game theory cannot be neglected because present technological development suggest that sooner or later someone would take full advantage of quantum theory and may use quantum strategies to beat us at some realistic game. At present, it is difficult to find out if human consciousness explores quantum phenomena although it seems to be at least as mysterious as the quantum world. Humans have been applying quantum technologies more or less successfully since its discovery. Does it mean that our intelligence is being transformed into quantum artificial intelligence (cf. quantum anthropic principle as formulated in [7])? Humans have already overcome several natural limitations with help of artificial tools. Is information processing waiting for its turn?

2 Quantization of games

Classical games usually cannot be quantized in a unique way because they are only asymptotical “shadows” of a wide spectra of quantum models. There are two obvious modifications of classical simulation games.

1 – prequantization: Redefine the game so that it becomes a reversal operation on qubits representing player’s strategies. This already allows

for quantum coherence of strategies¹.

2 – quantization: Reduce the number of qubits and allow arbitrary unitary² transformation so that the basic features of the classical game are preserved. At this stage ancillary qubits can be introduced so that possibly all quantum subtleties can be explored (e.g. entanglement, measurements and the involved reductions of states, nonlocal quantum gates etc.).

One of the most appealing features of quantum games is the possibility that strategies can influence each other and form collective strategies. Elsewhere [9], we have defined the alliance as the gate CNOT (\mathcal{C}) regardless of its standard name *controlled-NOT* because it can be used to form collective strategies as follows. Most of two-qubit quantum gates are universal in the sense that any other gate can be composed of a universal one [8]-[11]. Therefore it is sufficient to describe a collective tactic of N players as a sequence of various operations $\mathcal{U}_{z,\alpha}$ belonging to $SU(2)$ performed on one-dimensional subspaces of players' strategies and, possibly, alliances \mathcal{C} among them (any element of $SU(2^N)$ can be given such a form [12]). Alliances are, up to equivalence, the only ways of forming collective games. An alliance has the explicit form $CNOT := |0\rangle\langle 0| \otimes I + |1\rangle\langle 1| \otimes NOT$, where the tactic NOT is represented in the qubit basis ($|0\rangle, |1\rangle$) by the matrix $\begin{pmatrix} 0 & i \\ i & 0 \end{pmatrix} \in SU(2)$. An alliance allows the player to determine the state of another player by entering into an alliance and measuring her resulting strategy. This process is shortly described as

$$\mathcal{C} |0'\rangle|m'\rangle = |m'\rangle|m'\rangle, \quad \mathcal{C} |m\rangle|0\rangle = |m\rangle|m\rangle,$$

where $m = 0, 1$. The corresponding diagrams are shown in Fig. 1. The left diagram presents measurement of the observable \mathcal{X}' and the right one measurement of \mathcal{X} . Any measurement would demolish possible entanglement of strategies. Therefore entangled quantum strategies can exist only if the players in question are ignorant of the details of their strategies. To illustrate the problem we analyse three simple games involving alliances. They can be used as partial solutions in more complicated situations.

¹This may result from nonclassical initial strategies or classically forbidden measurements of the state of the game (end of the game).

²At least one of the performed (allowed) operations should not be equivalent to a classical one. Otherwise we would get a game equivalent to some variant of the prequantized classical game.

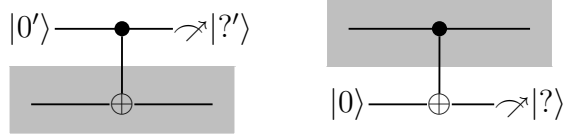

Figure 1: The alliance as a mean of determining others' strategies. The sign “↗” at the right ends of lines representing qubits symbolizes measurement.

3 Quantum solution to the Newcomb's paradox

Let us consider the simple quantum circuit presented in Fig. 2. Any circuit is more or less vulnerable to random errors. The gate I/NOT is defined as a randomly chosen gate from the set $\{I, NOT\}$ and is used to switching-off the circuit in a random way. It can be generalized to have some additional control qubits. In a game-theoretical context such circuits can be used to neutralization of disturbances caused by measuring strategies, cf [13]. For

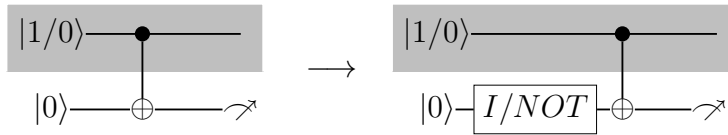

Figure 2: Neutralization of a quantum measuring system by a switch I/NOT applied ($I/NOT \rightarrow NOT$), when $|1/0\rangle = |1\rangle$ (see the text).

example, it can be applied to solve the famous Newcomb's free will paradox [14]. The problem, originally formulated by William Newcomb in the 1960, was described by Martin Gardner in the following way. An alien Omega being a representative of alien civilization (player 2) offers a human (player 1) a choice between two boxes. The player 1 can take the content of both boxes or only the content of the second one. The first one is transparent and contains \$1000. Omega declares to have put into the second box that is opaque \$1000000 (strategy $|1\rangle_2$) but only if Omega foresaw that the player 1 decided to take only the content of that box ($|1\rangle_1$). A male player 1 thinks: *If Omega knows what I am going to do then I have the choice between \$1000 and \$1000000. Therefore I take the \$1000000* (strategy $|1\rangle_1$). A female player 1 thinks: *Its obvious that I want to take the only the content of the second*

box therefore Omega foresaw it and put the \$1000000 into the box. So the one million dollar **is** in the second box. Why should I not take more – I take the content of both boxes (strategy $|0\rangle_1$). The question is whose strategy, male’s or female’s, is better? In the measuring system presented in Fig. 2 the initial value $|0\rangle$ of the lower qubit corresponds to the male strategy and the values $|1\rangle$ and $|0\rangle$ of the upper qubit correspond to male and female tactics, respectively. The outcome $|0\rangle$ of a measurement performed on the lower qubit indicates the opening of both boxes with contents prepared by Omega before the alliance *CNOT* was formed. If Omega installed in the circuit a breaker of the form *I/NOT* (before or after the alliance *CNOT* he would use it when (and only then) the human adopted the female tactics. But this would mean that Omega is cheating (the breaker is installed after the alliance) or is able to foretell the future (the breaker is installed before the alliance). In the quantum setting the situation is different. The quantization of the

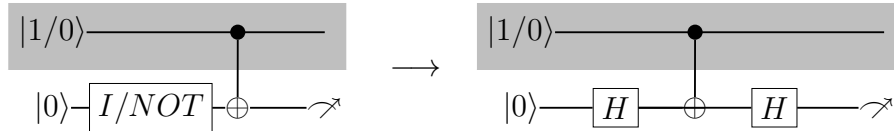

Figure 3: Solution to the Newcomb’s paradox: quantum device that neutralizes measurement. In the quantization process the gate *I/NOT* is replaced by a qutrojan (see the text) that acts independently of the value of the qubit $|1/0\rangle$ and is composed of two Hadamard gates *H*.

problem is presented in Fig. 3. It consists in replacing of the circuit-breaker *I/NOT* by a pair of Hadamard gates $H := \frac{i}{\sqrt{2}} \begin{pmatrix} 1 & 1 \\ 1 & -1 \end{pmatrix} \in SU(2)$. Due to their jamming effect on the human’s tactics, we can call them a quantum Trojan horse (qutrojan)³. We can hardly use the term trojan with respect to the circuit-breaker *I/NOT* because of its paradoxical correlation with human tactics. Note that $H \cdot NOT \cdot H = \begin{pmatrix} -i & 0 \\ 0 & i \end{pmatrix}$, hence any attempt at measuring squared absolute values of coordinates of the human strategy qubit will not detect any effectiveness of the female tactics.

³Problems connected with the definition of trojan are discussed in [16].

4 Quantum Metropolis algorithm

An obvious generalization of the CNOT gate consists in adding more control bits. Let us consider a cellular automaton that is able to implement the popular Metropolis algorithm [17]. Such an automaton can be constructed by forming a network of identical sub-automata (that is implementing the same tactics) joined by classical communication channels. Were the communication channels quantum (that is admitting nonlocal alliances), the system formed by automata implementing arbitrary one qubit tactics would be a fully-fledged quantum computer of distributed architecture [18]. In order to eliminate the possible feedback catastrophe in single simulation step only part of the cells should be activated [19]. Let us restrict ourselves to (local) quantization procedure such that only the sub-automata are acted on. To simulate the 1D Ising model⁴ the network has the cyclic group Z^N structure and the automaton can be built in the form presented in Fig. 4.

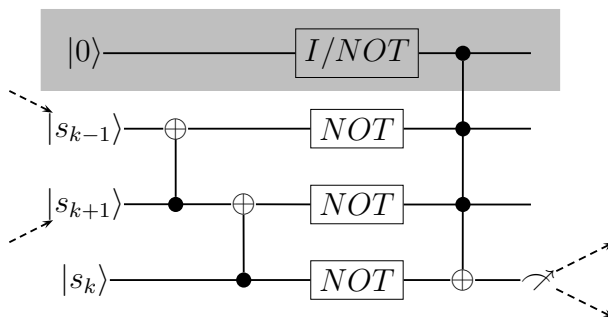

Figure 4: Tactics of the k -th cell of a network simulating the Metropolis algorithm (Ising chain).

The sub-automaton (cell) is built in such a way that the activation does not change its strategy $|s_k\rangle$ ($I/NOT \rightarrow NOT$ what happens with the probability p) only if the strategies of the neighboring cells $|s_{k-1}\rangle$ and $|s_{k+1}\rangle$ have the same strategies. The dashed lines represent one bit information flows between neighboring cells. A simple quantization of this system that does not influence results of the simulation consists in replacing the switch I/NOT with such a one-qubit tactics U that $|\langle 1|U|0\rangle|^2 = p$. The quantization results in elimination of a time-consuming pseudo-random numbers generator that is

⁴An extended description of such simulation of the Ising model can be found in the paper [20] were a more complicated automaton is used to this end.

necessary for correct performance of the switch I/NOT . The sub-automaton can be rebuilt so that the network will simulate more dimensional Ising model [20]. Going farther in this direction, by choosing for the measurement basis (in a preselected or random way) for the strategy $|s_k\rangle$ various conjugated bases that are equivalent to additional one-qubit tactics⁵ [21] we will be able, for example, to simulate the evolution of cliques that might form in quantum market games [22, 9]. Note that this sort of a quantum version of the Metropolis algorithm can be effectively implemented on a classical computer.

5 The Elitzur–Vaidman circuit–breaker

Let us now consider a modification of the method of jamming of the strategy measuring game in which the circuit-breaker gate I/NOT is implemented as a part in a separate switching-off strategy, cf. Fig. 5. To this end the alliance $CNOT$ was replaced by the Toffoli gate (Controlled-Controlled-NOT). Contrary to former case we are now interested in effective accomplishment of the measurement. Therefore we assume that there are no correlations between the state of the gate I/NOT and the strategy $|1/0\rangle$. The role of the gate NOT that comes before the measurement of the central qubit is to guarantee that the measurement of the state $|1\rangle$ stands for the switching-off of the subsystem consisting of the two bottom qubits. To quantize this game

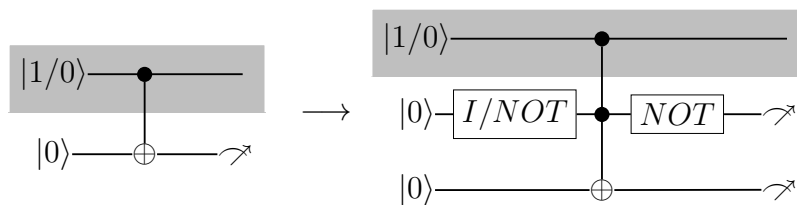

Figure 5: Modification of the system by adding a switching-off strategy.

we will follow Elitzur and Vaidman [23] who explored Mauritius Renninger’s idea of the *negative measurement* [24], see Fig. 6. The method consists in gradual unblocking of the switching-off strategy (n steps of $\sqrt[n]{NOT}$) and at each step, if only the change of the third qubit (measuring the first qubit) is

⁵To perform this measurement, one simply unitarily transforms from the basis we wish to perform the measurement into the computational basis, then measure.

observed, the whole measurement is given up. So the game is stopped by the “exploding bomb”⁶ what happens if at some step the value of the auxiliary strategy measured after the alliance $CNOT$ is measured to be $|1\rangle$, see Fig. 6. The tactics $\sqrt[n]{NOT}$ of gradual unblocking is represented by the operator:

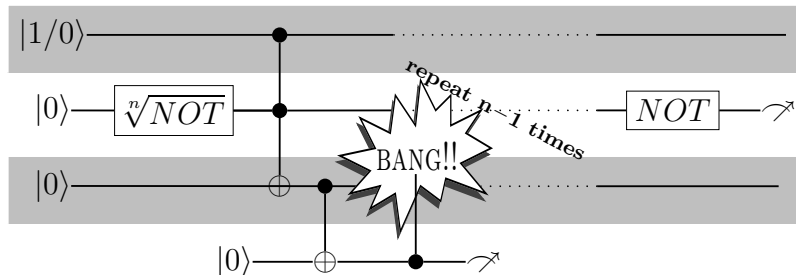

Figure 6: The Elitzur–Vaidman tactics of gradual unblocking of the switching-off strategy.

$$\sqrt[n]{NOT} := I \cos \frac{\pi}{2n} + NOT \sin \frac{\pi}{2n} = e^{NOT \frac{\pi}{2n}} \in SU(2).$$

The probability of continuation of the game after one step is equal to

$$|\langle 0 | \sqrt[n]{NOT} | 0 \rangle|^2 = \cos^2\left(\frac{\pi}{2n}\right)$$

and all steps are successfully accomplished with probability $\cos^{2n}\left(\frac{\pi}{2n}\right) = 1 - \frac{\pi^2}{4n} + \frac{\pi^4}{32n^2} + O(n^{-3})$. Therefore in the limit $n \rightarrow \infty$ the probability of stopping the game tends to zero⁷. The inspection of the value of the first qubit with help of the third qubit gets a transcendental dimension because if $|1/0\rangle = |1\rangle$ the measuring system is switched-off and if $|1/0\rangle = |0\rangle$ the switching-off strategy cannot be unblocked. The bomb plays the key role in the game because it freezes the second qubit in the state $|0\rangle$ — this is the famous quantum Zeno effect [26]. But the information about the state of the first qubit ($|0\rangle$ or $|1\rangle$) can only be acquired via the effectiveness of the unblocking of the second qubit. The presented implementation and analysis of the Elitzur-Vaidman circuit-breaker paves the way for a completely new class

⁶Note that exploding bombs can actually be priceless for implementations quantum algorithms, cf. [25].

⁷The limit can be found by application of the de L’Hospital rule to $\ln \cos^{2n} \frac{\pi}{2n}$.

of technologies that might be shocking for those unacquainted with quantum effects. For example, if the first qubit represents a result of quantum computation then such a breaker allows to access in that part of the Deutsch Multiversum [27] where this computer is turned off [28]. If the first qubit of the circuit presented in Fig. 6 is fixed in the state $|1\rangle$ then this machinery can be to no demolition measurement that, for example, is able to select bombs with damaged fuse. The respective measuring system is presented in Fig. 7 (the shaded-in qubits in Fig. 6 are absent because they are redundant). The breaker *Controlled(I/NOT)* that replaces the alliance *CNOT* is in the state $I/NOT = I$ if the bomb fuse is damaged and in the state $I/NOT = NOT$ if the fuse is working. The result $|1\rangle$ of measurement of the first qubit tell

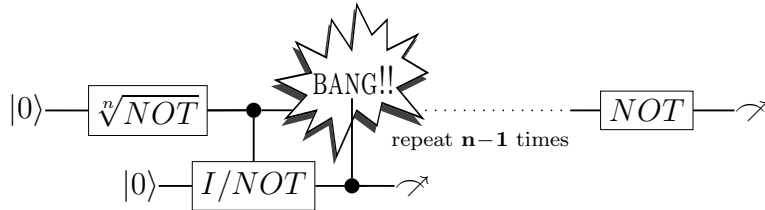

Figure 7: Safe Elitzur–Vaidman bomb tester.

us that the bomb is in the working order. This is so because the working bomb always reduces this qubit to $|0\rangle$ after the transformation $\sqrt[n]{NOT}$ (quantum Zeno effect). Of course such a bomb tester (and the Elitzur–Vaidman circuit–breaker) can be constructed on the basis of the quantum anti-Zeno effect [29]. In this case the working but unexploded bomb accelerates the evolution of the system instead of “freezing” it. Such alternative tester is presented in Fig. 8, where the working bomb causes at any of the n stages the increase of $\frac{\pi}{2n}$ in the phase φ of the cumulative tactics $e^{NOT\varphi}$. Let us

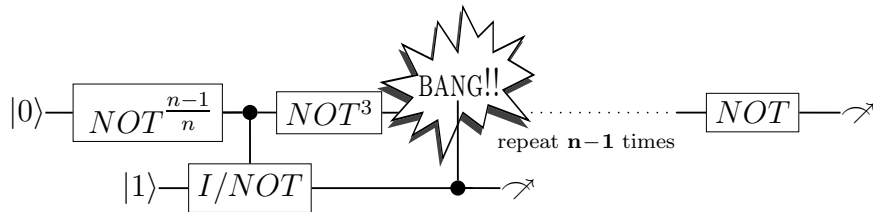

Figure 8: Bomb tester constructed on the basis of the quantum anti-Zeno effect.

define $V(\beta) := NOT \cos \beta + (I \cos \alpha + H \cdot NOT \cdot H \sin \alpha) \sin \beta$. It is easy to show that $V(\beta_2) \cdot NOT^3 \cdot V(\beta_1) = V(\beta_1 + \beta_2)$. Therefore we can replace the gate $NOT^{\frac{n-1}{n}}$ with any of the gates

$$NOT \cos \frac{\pi}{2n} + (I \cos \alpha + H \cdot NOT \cdot H \sin \alpha) \sin \frac{\pi}{2n},$$

where $\alpha \in [0, 2\pi)$. But only for $\alpha = 0, \pi$ such gate belongs to the class $e^{NOT\varphi}$ and we can claim that the transformation NOT results from the acceleration or freezing of the evolution of the system. For $\alpha \neq 0, \pi$ we observe sort of para-Zeno effect because the measurement of the entangled with the qubit in question qubit stops the free evolution corresponding to a damaged bomb. Consider a slight modification of the circuit presented in Fig. 9, where now

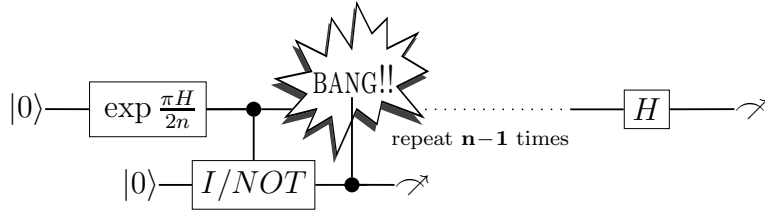

Figure 9: Supply-demand switch.

$\exp \frac{\pi H}{2n} = I \cos \frac{\pi}{2n} + H \sin \frac{\pi}{2n}$. Again, we can avoid explosion with a high probability because $(|\cos \frac{\pi}{2n} + \frac{i}{\sqrt{2}} \sin \frac{\pi}{2n}|^2)^n > \cos^{2n} \frac{\pi}{2n}$. In this case the information revealed by the breaker is more subtle because the “bomb” can only cause transition to a corresponding state in the conjugated basis [21]. Nevertheless, the bomb being in the working order cases the strategy change. For example, in quantum market games [9] models the supply strategy is changed to the demand one. Such a mechanism can be used to stabilize prices on a futuristic quantum markets if the market crash is yet only a menace: an instability verifiable only by provoking counterfactual crash.

6 Identification of strategies

Actually, any quantum computation is a potential quantum game if we manage to reinterpret it in game-theoretical terms. Identification of strategies is often a challenge in such process. To illustrate the method let us consider Wiesner’s counterfeit-proof banknote [21]. This is the first quantum secrecy

method (elimination of effective eavesdropping). As a quantum game it consists in a finite series of sub-games presented in Fig. 10. The arbiter Trent produces a pair of random qubits $|\psi_T\rangle$ and $|\psi_{T'}\rangle$. The polarization of the qubit (strategy) $|\psi_T\rangle$ is known to Trent and is kept secret. The qubit $|\psi_{T'}\rangle$ is ancillary. Alice qubit $|\psi_A\rangle$ describes her strategies $|I\rangle$ and $|0\rangle$. The first move is performed by Alice. Her strategy $|I\rangle$ consists in switching the Trent's qubits $|\psi_T\rangle$ and $|\psi_{T'}\rangle$. The strategy $|0\rangle$ consists in leaving the Trent's qubits intact. These moves form the controlled-swap gate [13]. Her opponent Bob wins only if after the game Trent learns that his qubit $|\psi_T\rangle$ has not been changed.

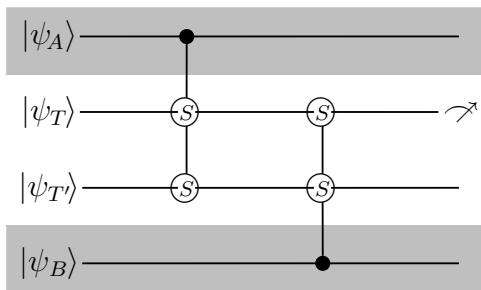

Figure 10: Identification game constructed from two controlled-swap gates.

To win Bob must always begin with with a strategy identical to the one used by Alice. If there is no coordination of moves between Alice and Bob the probability of Bob's success exponentially decreases with growing number of sub-games being played and is negligible even for a small number of sub-games. Although Alice and Bob's strategies are classical eavesdropping is not possible if Trent uses arbitrary polarizations $|\psi_T\rangle = |0\rangle + z|I\rangle$, $z \in \bar{\mathcal{C}} \simeq S_2$ (in the projective nonhomogeneous coordinates). This game can be quantized by elimination of the ancillary qubit $|\psi_{T'}\rangle$. Then Alice and Bob's strategies should be equivalent to controlled-Hadamard gates. (The reader can easily represent the controlled-Hadamard gates in terms of the alliance *CNOT* and 1-qubit tactics, cf. [13].) In this case Trent's qubit is changed only if Alice adopts the strategy $|I\rangle$ that result in $|\psi_T\rangle = |0\rangle + z|I\rangle \longrightarrow |0\rangle + \frac{1-z}{1+z}|I\rangle$ (quantum Fourier transform), see Fig. 11. The original Wiesner's idea was to encode the secret values of $|\psi_T\rangle$ that result from Alice moves in the series of sub-games on an otherwise numbered banknote. In addition, the issuer Trent takes over the role of Alice and records the values of $|\psi_T\rangle$ and $|\psi_A\rangle$ with the label being the number of the banknote. The authentication of the

banknote is equivalent to a success in the game when Bob’s strategy is used against that recorded by Trent (if Bob wins then his forgery is successful).

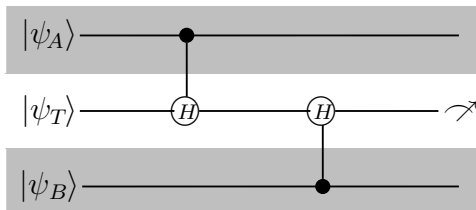

Figure 11: Quantum identification game constructed from two controlled–Hadamard gates (Wiesner’s banknote).

The introduction of classically impossible strategies results in better security against quantum attack (pretending to be Alice). Eavesdropping of the state $|\psi_T\rangle$ modified by Alice’s strategy is ineffective even if Trent limits himself to polarizations from the set $\{|0\rangle, |I\rangle\}$. It is possible that an analogous reduction of qubits allows to exponentially reduce the complexity of quantum algorithms. Therefore quantum games may sometimes be the only feasible alternatives if the classical problems are computationally too complex to be ever implemented.

7 Kernels and shells of quantum computers: quantum game model of mind

In the former section we have put great emphasis on distinction between measuring qubits and qubits being measured. The later were shaded-in in figures. Analogously to the terminology used in computer science, we can distinguish the shell (the measuring part) and the kernel (the part being measured) in a quantum game that is perceived as an algorithm implemented by a specific quantum process. Note that this distinction was introduced on the basis of abstract properties of the game quantum algorithm, quantum software) and not properties of the specific physical implementation. Quantum hardware would certainly require a lot of additional measurements that are nor specific to the game (or software), cf. the process of starting a one-way quantum computer. Adherents of artificial intelligence (AI) should welcome the great number of new possibilities offered by quantum approach to AI (QAI). For

example, consider a Quantum Game Model of Mind (QGMM) exploring the confrontation of quantum dichotomy between kernel and shell with the principal assumption of psychoanalysis of dichotomy between consciousness and unconsciousness [30]. The relation is as follows.

- Kernel represents the Ego, that is the conscious or more precisely, that level of the psyche that it is aware of its existence (it is measured by the Id). This level is measured due to its coupling to the Id via the actual or latent (not yet measured) carriers of consciousness (in our case qubits representing strategies)
- Shell represents the Id that is not self-conscious. Its task is monitoring (that is measuring) the kernel. Memes, the AI viruses [31], can be nesting in that part of the psyche.

Memes being qutrojans, that is quantum parasitic gates (not qubits!) can replicate themselves (qubits cannot – no-cloning theorem). Very little is known about the possible threat posed by qutrojans to the future of quantum networks. In quantum cryptography teleportation of qubits will be helpful in overcoming potential threats posed by qutrojans therefore we should only worry about attacks by conventional trojans [32]. If the qutrojan is able to replicate itself it certainly deserves the name quivirus. A consistent quantum mechanism of such replication is especially welcome if quantum computers and cryptography are to become a successful technology. In the QGMM approach external measuring apparatus and “bombs” reducing (projecting) quantum states of the game play the role of the nervous system providing the “organism” with contact with the environment that sets the rules of the game defined in terms of supplies and admissible methods of using of tactics and pay-offs [9]. Contrary to the quantum automaton put forward by Albert [33] in QGMM model there is no self-consciousness – only the Ego is conscious (partially) via alliances with the Id and is infallible only if the Id is not infected with memes. Alliances between the kernel and the Id (shell) form states of consciousness of QAI and can be neutralized (suppressed) in a way analogous to the quantum solution to the Newcomb’s paradox [14]. In the context of unique properties of quantum algorithms and their potential applications the problem of deciding which model of AI (if any) faithfully describes human mind is fascinating but a secondary one. The discussed above variant of the Eitzur-Vaidman breaker suggests that the addition of the third qubit to the kernel could be useful in modelling the process of forming the

psyche by successive decoupling qubits from the direct measurement domain (and thus becoming independent of the shell functions). For example dreams and hypnosis could take place in shell domains that are temporarily coupled to the kernel in this way. The example discussed in the previous section illustrates what QAI intuition resulting in a classically unconveyable belief might be like. What important is, QAI reveals more subtle properties than its classical counterparts because it can deal with counterfactual situations [28, 34] and in that sense analyze hypothetical situations (imagination). Therefore QAI is anti-Jourdainian: Molière's Jourdain speaks in prose without knowing it; QAI might be unable to speak but know it would have spoken in prose were it possible.

8 Conclusion

Since the publication of Gödel theorems [35] the opinion that human mind dominates any conceivable computer prevails. But in the light of quantum information processing [13] and scepticism concerning the role of quantum phenomena in brain processes [36] we might be doomed to dreary future of coherent states of quantum matter dominating human mind. A new fascinating field of research has been started.

Acknowledgements This paper has been supported by the **Polish Ministry of Scientific Research and Information Technology** under the (solicited) grant No **PBZ-MIN-008/P03/2003**.

References

- [1] Meyer, D. A., Quantum strategies, *Physical Review Letters* **82** (1999) 1052.
- [2] Eisert, J., Wilkens, M., Lewenstein, M., Quantum games and quantum strategies, *Physical Review Letters* **83** (1999) 3077.
- [3] Piotrowski, E. W., Śładkowski, J., The next stage: quantum game theory, in *Mathematical Physics Frontiers*, Nova Science Publishers, Inc. (2004); quant-ph/0308027.

- [4] Piotrowski, E. W., Śladkowski, J., An invitation to quantum game theory, *International Journal of Theoretical Physics* **42** (2003) 1089.
- [5] Milnor, J., Games against nature, in Thrall, R. M., Coombs, C. H., Davis, R. L., (eds.), *Decision Processes*, John Wiley & Sons, New York (1954) p. 49.
- [6] Iqbal A., Toor A. H., Evolutionarily stable strategies in quantum games, *Physics Letters A* **280** (2001) 249.
- [7] Piotrowski, E. W., Śladkowski, J., Trading by quantum rules – quantum anthropic principle, *International Journal of Theoretical Physics* **42** (2003) 1101.
- [8] Deutsch, D., Barenco, A., Eckert, A., Universality in quantum computation, *Proc. R. Soc. London A* **449** (1995) 669.
- [9] Piotrowski, E. W., Śladkowski, J., Quantum computer: an appliance for playing market games, *Int. J. Quant. Information*, **2** (2004) 495.
- [10] Eisert, J., Jacobs, K., Papadopoulos, P., Plenio, M. B., Optimal local implementation of non-local quantum gates, *Phys. Rev. A* **62** (2000) 052317.
- [11] Yimsiriwattana, A., Lomonaco Jr, S. J., Generalized GHZ states and distributed quantum computing; quant-ph/0402148.
- [12] Barenco A., et al., Elementary gates for quantum computation, *Phys. Rev. A* **52** (1995) 3457.
- [13] Nielsen, M. A., Chuang, I. L., *Quantum Computation and Quantum Information*, Cambridge University Press, Cambridge (2000).
- [14] Piotrowski, E. W., Śladkowski, J., Quantum solution to the Newcomb's paradox, *Int. J. Quant. Information* **1** (2003) 395.
- [15] Gardner, M., *Aha! Gotcha. Paradoxes to puzzle and delight*, Freeman & Co, San Francisco (1982).
- [16] Timpleby, H., Anderson, A., Cairn, P., A framework for modelling trojans and computer virus infections, *Computer Journal* **41** (1999) 96.

- [17] Metropolis, N., Rosenbluth, A., Rosenbluth, M. N., Teller, A. H. and Teller, E., Equation of state calculations by fast computing machines, *J. Chem. Phys.*, **21** (1953) 1087.
- [18] Yimsiriwattana, A., Lomonaco Jr., S. J., Distributed quantum computing: A distributed Shor algorithm, *Proceedings of SPIE*, **5436** (2004) 360.
- [19] Vichniac, G. Y., Simulating physics with cellular automata, *Physica D* **10** (1984) 96.
- [20] Cole, J. H., Hollenberg, L. C. L. and Prawer, S., An algorithm for simulating the Ising model on a type-II quantum computer, [quant-ph/0404143](http://arxiv.org/abs/quant-ph/0404143).
- [21] Wiesner, S., Conjugate coding, *SIGACT News* **15/1** (1983) 78; <http://kh.bu.edu/qcl/pdf/wiesners198316024137.pdf>.
- [22] Piotrowski, E. W., Śładkowski, J., Quantum Market Games, *Physica A* **312** (2002) 208.
- [23] Penrose, R., *Shadows of the Mind*, Cambridge University Press, Cambridge (1994).
- [24] M. Renninger, Zum Wellen–Korpuskel–Dualismus, *Zeitschr. Phys.* **136** (1953) 251.
- [25] Rudolph, T. and Grover, L., Quantum searching a classical database (or how we learned to stop worrying and love the bomb); [arXiv:quant-ph/0206066](http://arxiv.org/abs/quant-ph/0206066).
- [26] Facchi, P., Gorini, V., Marmo, G., Pascazio, S. and Sudarshan, E. C. G., Quantum Zeno dynamics, *Physics Letters A* **275** (2000) 12.
- [27] Deutsch, D., *The fabric of reality*, Penguin, London 1998.
- [28] Mitchison, G. and Jozsa, R., Counterfactual computation, *Proc. Roy. Soc. (Lond.) A* 2000; [quant-ph/9907007](http://arxiv.org/abs/quant-ph/9907007).
- [29] Facchi, P., Nakazato, H. and Pascazio, S., From the Quantum Zeno to the Inverse Quantum Zeno Effect, *Physical Review Letters* **86** (2001) 2699.

- [30] Freud, Z., *Ich und das Es*, Internationaler Psychoanalytischer Verlag, Leipzig (1923).
- [31] Dawkins, R., *The selfish gene*, Oxford University Press, Oxford (1976).
- [32] Lo, H.-K., *Will quantum cryptography ever become a successful technology in the marketplace?*, quant-ph/9912011; note that the version published in Physics World omitts this problem.
- [33] Albert, D. Z., On quantum-mechanical automata, *Physics Letters A* **98** (1983) 249.
- [34] Vaidman, L., *Interaction-free measurements*, quant-ph/9610033.
- [35] Nagel, E., Newman, J. R., *Gödel's proof*, New York University Press, New York 1958.
- [36] *The large, the small and the human mind*, Penrose, R. (ed.), Cambridge University Press, Cambridge (1997).