

Conference Key Agreement and Quantum Sharing of Classical Secrets with Noisy GHZ States

Kai Chen and Hoi-Kwong Lo

Abstract— We propose a wide class of distillation schemes for multi-partite entangled states that are CSS-states. Our proposal provides not only superior efficiency, but also new insights on the connection between CSS-states and bipartite graph states. We then apply our distillation schemes to the tri-partite case for three cryptographic tasks—namely, (a) conference key agreement, (b) quantum sharing of classical secrets and (c) third-man cryptography. Moreover, we construct “prepare-and-measure” protocols for the above three cryptographic tasks which can be implemented with the generation of only a single entangled pair at a time. This gives significant simplification over previous experimental implementations which require two entangled pairs generated simultaneously. We also study the yields of those protocols and the threshold values of the fidelity above which the protocols can function securely. Rather surprisingly, our protocols will function securely even when the initial state does not violate the standard Bell-inequalities for GHZ states.

Index Terms— Cryptography, key Agreement, secret sharing, conference key, entanglement, entanglement distillation, quantum cryptography, quantum information.

I. INTRODUCTION

A. Motivations

ENTANGLEMENT is the hallmark of quantum mechanics. There are many different types of entanglement. While the classification of bipartite pure-state entanglement has been solved, currently the classification of multi-partite entanglement and mixed state bipartite entanglement is a most important open problem (for a recent review, see [1]). A particularly useful idea for the study and quantification of entanglement is entanglement distillation [2], [3]. Given a large number, say n , of copies of an initial mixed state ρ , one may ask how many, m , standard states (e.g., Einstein-Podolsky-Rosen (EPR) states and Greenberger-Horne-Zeilinger (GHZ) states) one can distill out in the end by using only local operations and classical communications? The ratio m/n , in the limit of large n , optimized over all possible procedures denotes the amount of distillable entanglement in the original state, ρ . Unfortunately, except for the case of bipartite pure states, it is generally hard to work out the optimal strategy for entanglement distillation. A simpler problem is to construct explicit strategies for entanglement distillation. Their yields will give lower bounds on the amount of distillable entanglement.

The authors are with the Center for Quantum Information and Quantum Control, Department of Electrical and Computer Engineering (ECE) and the Department of Physics, University of Toronto, Toronto, ON M5S 3G4, Canada. (email: kchen@physics.utoronto.ca). (email:hklo@comm.utoronto.ca).

Recently, the distillation of entanglement from multi-partite entangled states has attracted a lot of attention [4], [5], [6], [7], [8], [9]. Direct distillations of multipartite entanglement (such as GHZ states) have some advantages over concatenated distillation of partite entanglement (EPR states). Indeed, for the GHZ state, direct distillations have been shown to be more efficient than concatenated distillation of partite entanglement [4], [7], [8], [9]. Moreover, they tolerate a higher noise level [4], [7], [8], [9].

Another interesting line of research is the cryptographic applications of multi-partite entanglement. In particular, the idea of quantum sharing of classical secrets has been proposed in [10]. Such protocols guarantee security against an eavesdropper.

In this paper, we study the distillation of *multi*-partite entanglement and its applications to multi-party quantum cryptography. Our work provides the missing links between a diverse range of protocols and breaks several new grounds. First, whereas most previous results refer to the distillation of EPR states and GHZ states only, our formalism applies to a much wider class of states—CSS states. See Subsection III-A for a definition.

Second, we show that CSS-states are mathematically equivalent to bi-partite graph states. This insight allows one to reformulate the previous work on the distillation of bi-partite graph states [8], [9] in the systematic CSS formalism. Note that much of [8], [9] dealt with recurrence protocols whose yields go to zero in the limit that the fidelity of the final states tend to 1. In contrast, our re-formulation allows the direct application of hashing type protocols that give non-zero yields in the same limit.

Third, we construct distillation protocols of the GHZ state which give higher yields and tolerate much higher levels of noises than previous protocols. Our improved protocol exploits the non-trivial amount of mutual information between various variables which characterize a state, thus highlighting the power of systematic applications of concepts in classical information theory to entanglement distillation.

Fourth, we construct “prepare-and-measure” type protocols for multi-partite quantum cryptography. In a prepare-and-measure protocol, a (potentially dishonest) preparer sends an ordered sequence of identical multi-party entangled states to multiple parties through some noisy channels. The participants then perform some *local individual* quantum measurements and local *classical* computations and classical communications (CCCCs) between them. A prepare-and-measure type protocol is of practical interest because it has an advantage of being technologically less demanding. To implement a prepare-and-

measure protocol, the participants do not need to have full-blown quantum computers. The quantum computational part is done solely by a preparer (who prepares some standard entangled multi-partite state). What the participants need to do is to perform some local individual measurements. The rest are CCCCs that can be performed by strictly classical devices.

We note that the structure of a distillation protocol is directly relevant to its reduction here. In fact, in this paper, we find that a sufficient condition for a distillation protocol to be reducible to a prepare-and-measure type protocol is that it is distilling a CSS state and that the procedure involves post-selection steps in at most one of the two types (X-type or Z-type) of observables. This criterion generalizes the finding of Gottesman-Lo [11] to the multi-partite case. [Indeed, our study of prepare-and-measure type protocol for multi-party quantum cryptography is a generalization of the security proofs of BB84 by Shor-Preskill [12] and Gottesman-Lo [11]. The first proof of security of BB84 was by Mayers [13].]

We note that an N -party prepare-and-measure quantum cryptographic protocol only requires an $(N-1)$ -partite entanglement for its implementation. This is because the preparer has the option to measure her state immediately.

Fifth, we propose new protocols in multi-partite quantum cryptography. Specifically, we propose a conference key agreement protocol for three parties. Such a protocol can also be used to implement a previous protocol—third man cryptography.

Sixth, we give quantitative number to the yields of our protocols. Moreover, our protocols can tolerate rather high error rates. Surprisingly, our protocols will function securely even when the initial state fails to violate the standard Bell-inequalities for GHZ states. This observation may be of interest to the foundations of quantum theory.

Given that experimental works on quantum sharing of classical secrets and third-man quantum cryptography have recently been done [14], our work is very timely for their security analysis.

Seventh, we propose a simpler experimental realization of quantum sharing of classical secret schemes and third-man cryptography. Whereas previous experimental implementations [14] required the challenging feat of the generation of two entangled pairs via parametric down conversion, our new proposal has a clear advantage in requiring the generation of only a single EPR pair at a time. This leads not only to a substantial simplification of the experiment, but also a much higher rate. Our simpler protocols are based on the following idea. For the case of three parties, we convert our protocols to those involving only *bi*-partite entanglement. Therefore, our protocols have clear near term applications.

B. Organization of the paper

Our paper is organized as follows. In Section 2, we study the entanglement distillation of the GHZ state and present an improved hashing protocol. In Section 3, we generalize our results from the GHZ state to a general CSS state and show that the various subroutines that we have studied, in fact, apply to a general CSS state. In Section 4, we show

the equivalence of CSS states and bipartite graph states, thus connecting our work to other works [8], [9]. One part of this equivalence is due to Eric Rains [15]. In section 5, we discuss multi-party quantum cryptography and our adversarial model. In Section 6, we apply our formulation to study the three-party conference key agreement problem and show that for tripartite Werner state, conference key agreement is possible whenever the fidelity $F \geq 0.3976$. We note that our three-party conference key agreement protocol can be implemented with only bi-partite entanglement. In Section 7, we study the secret sharing problem and show that Alice can successfully share a secret with two parties Bob and Charlie if they share a Werner state with fidelity $F \geq 0.5372$. As before, our protocol can be implemented by using bi-partite entanglement only. We demonstrate in Section 7, that our protocols, which involve two-way classical communications, are provably better than any protocols involving only one-way classical communications. Finally, we show that, rather surprisingly, our protocols will work even when the initial GHZ-state does not violate the standard Bell inequalities for a GHZ-state.

II. DISTILLATION OF THE GHZ STATE

A. Some notations

Suppose three distant parties, Alice, Bob, and Charlie, share some tri-partite state. An example of a well-known tri-partite pure state is the GHZ state. It has the form of

$$|\Psi\rangle_{ABC} = \frac{1}{\sqrt{2}}(|0\rangle|0\rangle|0\rangle + |1\rangle|1\rangle|1\rangle). \quad (1)$$

The GHZ state is the $+1$ eigenstate of the following set of commuting observables

$$\begin{aligned} S_0 &= X \otimes X \otimes X, \\ S_1 &= Z \otimes Z \otimes I, \\ S_2 &= Z \otimes I \otimes Z. \end{aligned} \quad (2)$$

where $X = \begin{pmatrix} 0 & 1 \\ 1 & 0 \end{pmatrix}$, $Y = \begin{pmatrix} 0 & -i \\ i & 0 \end{pmatrix}$, $Z = \begin{pmatrix} 1 & 0 \\ 0 & -1 \end{pmatrix}$. In the stabilizer formulation, the three observables are the stabilizer generators of the GHZ state. For simplicity, we denote them by XXX , ZZI and ZIZ . By multiplying a combination of them together, we obtain other non-trivial stabilizer elements

$$-YYX, IZZ, -YXY, -XYY. \quad (3)$$

Let us define a GHZ basis as a three-qubit basis whose basis vectors are eigenvectors of the stabilizer generators listed in (2). More concretely, its basis vectors are

$$|\Psi_{p,i_1,i_2}\rangle_{ABC} = \frac{1}{\sqrt{2}}(|0\rangle|i_1\rangle|i_2\rangle + (-1)^p|1\rangle|\bar{i}_1\rangle|\bar{i}_2\rangle), \quad (4)$$

where p and the i 's are zero or one and a bar over a bit value indicates its logical negation. The p corresponds to whether a state is a $+1$ or -1 eigenvector of S_0 which we call the ‘‘phase bit of the state Eq. 4. The i_j correspond to whether a state is a $+1$ or -1 eigenvector of S_j for $j = 1, 2$, which we call the amplitude bits. More specifically, the three labels (p, i_1, i_2)

correspond to the eigenvalues of the 3 stabilizer generators S_0, S_1, S_2 by correspondence relation

$$\begin{aligned} \text{eigenvalue } 1 &\longrightarrow \text{label } 0, \\ \text{eigenvalue } -1 &\longrightarrow \text{label } 1. \end{aligned}$$

The GHZ-basis has 8 basis vectors and they may be labelled by 8 alphabets, $\alpha, \beta, \gamma, \delta$, etc.

Thus, we can label a density matrix which is diagonal in the GHZ-basis by the following form

$$\rho_{ABC} = \begin{pmatrix} p_{000} & 0 & 0 & 0 & 0 & 0 & 0 & 0 \\ 0 & p_{100} & 0 & 0 & 0 & 0 & 0 & 0 \\ 0 & 0 & p_{011} & 0 & 0 & 0 & 0 & 0 \\ 0 & 0 & 0 & p_{111} & 0 & 0 & 0 & 0 \\ 0 & 0 & 0 & 0 & p_{010} & 0 & 0 & 0 \\ 0 & 0 & 0 & 0 & 0 & p_{110} & 0 & 0 \\ 0 & 0 & 0 & 0 & 0 & 0 & p_{001} & 0 \\ 0 & 0 & 0 & 0 & 0 & 0 & 0 & p_{101} \end{pmatrix}$$

Similarly, given n trios of qubits, we define the n -GHZ-basis whose basis vectors are the tensor product states of the individual GHZ-basis states. An n -GHZ-basis state can be labelled by a n -string of the 8 alphabets (α, β , etc).

B. Non-identical independent distribution

In this paper, we often assume three distant parties, Alice, Bob and Charlie, share n trios of qubits. Notice that there is no need to assume an i.i.d. (independent identical distribution) for the n trios. Instead, we consider the most general setting where those n trios can be fully entangled among themselves and perhaps also with some additional ancillas held by an eavesdropper, Eve. In subsequent paragraphs, we will describe a depolarizing procedure, which can be performed by local operations and classical communications (LOCCs) by Alice, Bob and Charlie, that will turn the state of the n trios to one that is diagonal in the n -GHZ-basis mentioned in the last paragraph.

We will then describe an estimation procedure that will allow one to estimate the *type* of the n -string. [That is, to say the relative frequencies of those 8 alphabets in the string.] After that, we will introduce some entanglement distillation protocols (based on recurrence protocol and hashing protocols) that will work well, depending only on the type of the string.

Since in all the aforementioned procedures the important point is the type of a string, in what follows, it suffices in our analysis to consider the marginal density matrix (of the depolarized state) of a single trio. This is because this marginal density matrix precisely captures all the information about the type of a string.

C. Depolarization to the GHZ-basis diagonal states

Suppose three parties share a general tri-partite density matrix that is not necessarily diagonal in the GHZ-basis. In this subsection, we recall [5], [6] a general (LOCC) procedure that will allow the three parties to depolarize the state to one

that is diagonal in the GHZ-basis by the following steps. Start with the operator XXX , the three parties apply it with a probability $1/2$. Note that XXX is a tensor product of local unitary transformations and as such can be applied by LOCCs. Now, consider the next operator, ZZI , the three parties apply it with a probability $1/2$. Finally, consider the operator ZIZ , they also apply it with a probability $1/2$. The overall operation corresponds to

$$\begin{aligned} \rho &\longrightarrow \\ &\frac{1}{8}(\rho + (XXX)\rho(XXX) + (ZZI)\rho(ZZI) \\ &+ (YYX)\rho(YYX) + (ZIZ)\rho(ZIZ) + (YXY)\rho(YXY) \\ &+ (IZZ)\rho(IZZ) + (ZYY)\rho(ZYY)). \end{aligned} \quad (6)$$

The overall operation makes ρ diagonal in the basis of states in Eq. (4) without changing the diagonal coefficients. If one prefers, one can also arrange that $p_{011} = p_{111}, p_{010} = p_{110}$ and $p_{001} = p_{101}$ by random operations (5) a factor of any combination of the eight group elements, e.g. $X \begin{pmatrix} e^{i\phi_\alpha} & 0 \\ 0 & 1 \end{pmatrix} = \begin{pmatrix} 0 & 1 \\ e^{i\phi_\alpha} & 0 \end{pmatrix}$ does the same thing) where $\alpha = A, B, C$ and satisfies $\phi_A + \phi_B + \phi_C = 0$. See [5], [6] for details.

Now, given n trios of qubits, Alice, Bob and Charlie can apply the above randomization process to each trio. Therefore, they can turn the state of the n trios into a n -GHZ-basis diagonal state.

D. Estimation of relative frequencies of eight alphabets

Now, Alice, Bob and Charlie are interested in estimating the type of the n -string in the n -GHZ-basis. This can be achieved by the following random sampling argument. [This is related to the commuting observable argument in [16].]

More concretely, if Alice, Bob and Charlie pick a random sample of m out of the n trios and for each trio, measure along X, Y, Z basis (i.e., measure X, Y and Z observables) and compare the results of their local measurements, they can estimate the diagonal matrix elements in (5). In the limit of an infinite ensemble, they will find that the error rate for the seven non-trivial group elements is

$$\begin{aligned} XXX &: p_{100} + p_{101} + p_{110} + p_{111}, \\ ZZI &: p_{010} + p_{011} + p_{110} + p_{111}, \\ ZIZ &: p_{001} + p_{011} + p_{101} + p_{111}, \\ -YYX &: p_{100} + p_{011} + p_{010} + p_{101}, \\ IZZ &: p_{010} + p_{110} + p_{001} + p_{101}, \\ -YZY &: p_{100} + p_{011} + p_{110} + p_{001}, \\ -XYY &: p_{100} + p_{111} + p_{010} + p_{001}. \end{aligned} \quad (7)$$

Remark 1: Here, by an error rate of an observable, we mean the probability of getting a -1 eigenvalue. Note that an error occurs for an observable $-YYX = XXX \times ZZI$, if either XXX or ZZI has an error, but not both.

Remark 2: If denoting the error rates for all of the 7 non-trivial group elements by s_1, \dots, s_7 , one has

$$\begin{aligned}
p_{000} &= 1 - \frac{1}{4}(s_1 + s_2 + s_3 + s_4 + s_5 + s_6 + s_7), \\
p_{100} &= \frac{1}{4}(s_1 - s_2 - s_3 + s_4 - s_5 + s_6 + s_7), \\
p_{011} &= \frac{1}{4}(-s_1 + s_2 + s_3 + s_4 - s_5 + s_6 - s_7), \\
p_{111} &= \frac{1}{4}(s_1 + s_2 + s_3 - s_4 - s_5 - s_6 + s_7), \\
p_{010} &= \frac{1}{4}(-s_1 + s_2 - s_3 + s_4 + s_5 - s_6 + s_7), \\
p_{110} &= \frac{1}{4}(s_1 + s_2 - s_3 - s_4 + s_5 + s_6 - s_7), \\
p_{001} &= \frac{1}{4}(-s_1 - s_2 + s_3 - s_4 + s_5 + s_6 + s_7), \\
p_{101} &= \frac{1}{4}(s_1 - s_2 + s_3 + s_4 + s_5 - s_6 - s_7). \tag{8}
\end{aligned}$$

Since s_1, \dots, s_7 can be determined by LOCCs by Alice, Bob and Charlie, the above equations relate the diagonal matrix element of the marginal density matrix ρ_{ABC} of the measured trios to experimental observables.

Remark 3: In practice, only m out of the n trios are used as test trios. Nonetheless, the relative frequencies of the eight alphabets in the m test trios provide a reliable estimate of the relative frequency of the remaining $n - m$ trios. Bounds on random sampling estimation procedure has been discussed in the context of EPR pairs in [12], [19], [20]. The estimation procedure for a tri-partite (GHZ) state presented in this subsection is a natural generalization of the estimation procedure of a bi-partite (EPR) state presented in [18], in which the mutual information between variables is taken into account.

E. Multi-party hashing for distillation of GHZ states

We recall the results of Maneva and Smolin[7] on multi-partite entanglement distillation. Suppose N (> 2) parties share n (generally non-i.i.d.) mixed multi-partite states and they would like to distill out almost perfect (generalized) GHZ states. By using the notation in [7], one can write an unknown N -qubit state as an N -bit string $p, i_1, i_2, \dots, i_{N-1}$ where p corresponds to the eigenvalue of the operator $XX \cdots X$ and i_j ($j \geq 1$) corresponds to the eigenvalue of the operator $Z_1 Z_{j+1}$. (See Eq. (3) of [7].) Note that p denotes the phase error pattern (error syndrome) and i_j ($j \geq 1$) denotes the bit-flip error pattern.

Maneva and Smolin [7] found a high-yield multi-partite entanglement distillation protocol—multi-party hashing method. Their protocol generalizes the hashing protocol in the bipartite case [3]. Maneva and Smolin used multilateral quantum XOR gates (MXOR) as shown in the Fig. 1. The basic property of the MXOR gate acting on two GHZ-like states is

$$\begin{aligned}
&\text{MXOR}[(p, i_1, i_2, \dots, i_{N-1}), (q, j_1, j_2, \dots, j_{N-1})] \\
&= [(p \oplus q, i_1, i_2, \dots, i_{N-1}), \\
&\quad (q, i_1 \oplus j_1, i_2 \oplus j_2, \dots, i_{N-1} \oplus j_{N-1})], \tag{9}
\end{aligned}$$

where $(p, i_1, i_2, \dots, i_{N-1})$ and $(q, j_1, j_2, \dots, j_{N-1})$ denote the phase bit and amplitude bits for the first and second GHZ-like states.

Consider large number n (generally non-i.i.d.) multi-partite states. Let \hat{B}_0 denote a vector of n values that represents the random variable p 's for the n multi-partite states, while each of $\hat{B}_1 \hat{B}_2 \cdots \hat{B}_{N-1}$ a vector of n values for random variable i_1, i_2, \dots, i_{N-1} respectively for the n multi-partite states. Let b_0 denotes a random variable that represents the result of a random choice of an element in \hat{B}_0 . Similarly, let b_1, b_2, \dots, b_{N-1} respectively denote random variables that represent the result of random choices of $\hat{B}_1 \hat{B}_2 \cdots \hat{B}_{N-1}$. In other words, $H(b_0)$ denotes the averaged phase error rate over the n multi-partite states whereas $H(b_i)$ ($1 \leq i \leq N - 1$) denotes the averaged bit-flip error over the n multi-partite states for the i -th Z-type stabilizer generator.

Let us recall the following fact in random hashing. *Fact One:* If a vector is drawn from a set of size 2^s and a random linear hash is obtained with $s + O(\log(1/\epsilon))$ bits of output, then one can identify the vector uniquely with a probability at least $1 - \epsilon$.

In this paper, we are interested in the asymptotic limit of large n . Maneva and Smolin showed that the asymptotic yield (per input mixed state) of their hashing protocol is given by

$$D_h = 1 - \max_{j>0} [H(b_j)] - H(b_0), \tag{10}$$

where $H(x)$ is the standard Shannon entropy in classical information theory [21]. ($H(x) = -\sum_i p_i \log_2 p_i$ where p_i 's are the probabilities for the various distinct outcomes of a random variable x .) We define $H(b_j)$ ($j = 0, 1, \dots, N - 1$) here to be the entropy per bit in string b_j .

Maneva and Smolin's protocol consists of two steps. First, the parties perform a number of rounds of random hashing in the amplitude bits using the circuit shown in Fig. 1a). Second, they perform a number of rounds of random hashing in the phase bit(s) using the circuit shown in Fig. 1b).

Consider the first step—random hashing in amplitude bits. Here the goal is to find out the identity of the amplitude bits, b_j 's. Note that in each round of hashing of the amplitude bits, one *simultaneously* obtains multiple hash values, one for each variable b_j . Maneva and Smolin argued that the worst case scenario occurs when the variables, b_{j_1} and b_{j_2} , are independent.

Recall the aforementioned Fact One in (classical) random hashing that each round of hashing essentially reduces the entropy of a string by one bit. The number of rounds needed for amplitude hashing will, therefore, be given by $n \max_{j>0} [H(b_j)]$. [To be more precise, we mean $n(\max_{j>0} [H(b_j)] + \delta)$.] Now consider the second step—random hashing in phase bit(s). In the case of GHZ state, there is only one phase bit and, therefore, $nH(b_0)$ rounds of random hashing is needed to find out its value.

Let us now present our improvement over Maneva and Smolin. In what follows, we will argue that, in fact, the yield can be increased to be

$$D'_h = 1 - \max\{H(b_1), H(b_2|b_1)\} - H(b_0) + I(b_0; b_1, b_2), \tag{11}$$

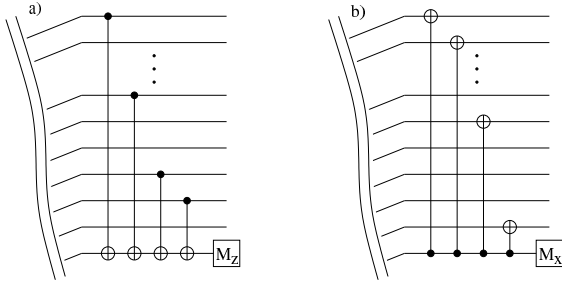

Fig. 1. Multi-party hashing circuits of Maneva and Smolin. Re-produced from Fig. 4 of [7]. “These hashes are done on large blocks of bits (indicated by the vertical ellipsis) and are done multilaterally (only one party’s operations are shown, the other $N - 1$ parties operations are identical). a) Finding a random subset parity on all the $b_{j>0}$ in parallel. In this case, the first, third, sixth and seventh states shown are XORed multilaterally into the last one which is then measured to determine the eigenvalue of the Z operator. b) Finding a random subset parity on b_0 . In this instance the parity of the first, second, fourth and eighth states shown are XORed with the last one, which is then measured in the eigenbasis of the X operator. Note the reversal of the direction of the XOR gates with respect to a).”

where $I(X; Y)$ is the standard mutual information between two random variables in classical information theory [21]. Note that there may be some correlations between b_0 and (b_1, b_2) and also between b_1 and b_2 i.e.,

$$\begin{aligned} I(b_0; b_1, b_2) &\geq 0, \\ I(b_1; b_2) &\geq 0. \end{aligned} \quad (12)$$

If these quantities are non-zero, we now argue that the parties can reduce the number of rounds of hashing relative to Maneva-Smolin’s protocol. Consider the following strategy

- 1 Alice, Bob and Charlie apply random hashing according to Fig. 1a to identify the pattern of b_1, b_2 . We now argue that only slightly more than $n[\max\{H(b_1), H(b_2|b_1)\}]$ rounds of random hashing is needed (we suppose here $H(b_1) \leq H(b_2)$). This is because of the following. We can imagine that the parties perform $nH(b_1)$ rounds of hashing to work out the value of b_1 ’s completely. Afterwards, the uncertainty in the variables b_2 ’s is reduced to $nH(b_2|b_1)$. Therefore, only $nH(b_2|b_1)$ rounds of hashing is needed to work out the value of b_2 ’s. Note that the hashing of b_1 and b_2 can be simultaneously executed. Therefore, in total, we still only need $n[\max\{H(b_1), H(b_2|b_1)\}]$ rounds of random hashing in amplitude bits.
- 2 They use the information on the pattern of b_1, b_2 (the amplitude bits) to reduce their ignorance on the pattern of b_0 (the phase bit) from $nH(b_0)$ to $nH(b_0|(b_1, b_2)) = n[H(b_0) - I(b_0; b_1, b_2)] = n[H(b_0, b_1, b_2) - H(b_1, b_2)]$.
- 3 They apply a random hashing through Fig. 1b to identify the pattern of b_0 . Now only (slightly more than) $n[H(b_0, b_1, b_2) - H(b_1, b_2)]$ rounds of random hashing is needed.

The yield of our method gives

$$D'_h = 1 - \max\{H(b_1), H(b_2|b_1)\} - H(b_0) + I(b_0; b_1, b_2). \quad (13)$$

F. Werner-like states

Werner-like states are a generalization of the Werner state [22] to the multi-partite case and has the form

$$\rho_W = \alpha |\Phi^+\rangle \langle \Phi^+| + \frac{1-\alpha}{2^N} I, \quad 0 \leq \alpha \leq 1, \quad (14)$$

where $|\Phi^+\rangle$ denotes the so-called cat state (i.e., GHZ-state for the tri-partite case) and I is the identity matrix. The fidelity ρ_W is $F = \langle \Phi^+ | \rho_W | \Phi^+ \rangle = \alpha + \frac{1-\alpha}{2^N}$. Using the GHZ-basis, we can rewrite it into

$$\begin{aligned} \rho_W &= F |0, 00 \dots 0\rangle \langle 0, 00 \dots 0| \\ &+ \frac{1-F}{2^N - 1} (I - |0, 00 \dots 0\rangle \langle 0, 00 \dots 0|). \end{aligned} \quad (15)$$

Remark 4: Using the random hashing method of Maneva and Smolin, for the tri-partite case, one obtains perfect GHZ states with nonzero yield whenever $F \geq 0.8075$ from Eq. (10). With our improved random hashing method in Eq. (13), we get a nonzero yield whenever $F \geq 0.7554$. This is a substantial improvement of the original method. We show the yield in Fig. 2.

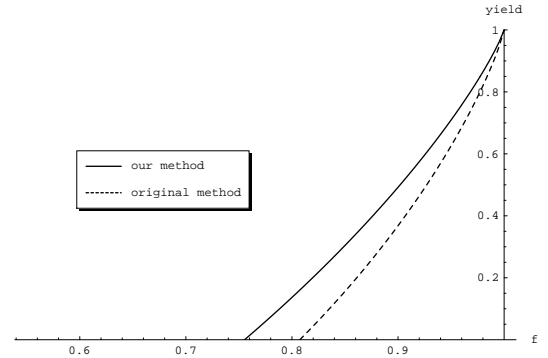

Fig. 2. Comparison of our improved hashing method with the original method of Maneva and Smolin’s [7] for a Werner-like state with initial fidelity f (see (14)).

G. Comparison of two random hashing methods

We show that, for the tri-partite case, our method gives a substantial improvement over the original method by two specific examples.

Example 1: Suppose we have a Werner-like state with initial fidelity of $F = 0.9$. Direct calculation gives $H(b_0) = H(b_1) = H(b_2) = 0.316$, $I(b_1; b_2) = 0.074$, $I(b_0; b_1, b_2) = 0.124$. We have the yield

$$\begin{aligned} D_h &= 1 - \max\{H(b_1), H(b_2)\} - H(b_0) \\ &= 1 - H(b_1) - H(b_0) \\ &= 0.368, \end{aligned}$$

through the original method while our improved method gives

$$\begin{aligned} D'_h &= 1 - \max\{H(b_1), H(b_2|b_1)\} - H(b_0) + I(b_0; b_1, b_2) \\ &= 1 - H(b_1) - H(b_0) + I(b_0; b_1, b_2) \\ &= 0.492. \end{aligned}$$

We see that one can obtain a substantially higher yield with our method. Our method reduces the number of rounds for identifying the pattern of phase bit (from $H(b_0) = 0.316$ in the original method to $H(b_0|(b_1, b_2)) = 0.192$). Though here $I(b_1; b_2) > 0$, one still needs $nH(b_1)$ rounds of random hashing for identifying the pattern of amplitude bit.

Example 2: Suppose we have a GHZ-basis diagonal state with initial fidelity of $F = 0.9$ and the diagonal elements for its density matrix are

$$\begin{pmatrix} p_{000} \\ p_{100} \\ p_{011} \\ p_{111} \\ p_{010} \\ p_{110} \\ p_{001} \\ p_{101} \end{pmatrix} = \begin{pmatrix} 0.9 \\ 0.01 \\ 0.01 \\ 0.01 \\ 0.015 \\ 0.015 \\ 0.02 \\ 0.02 \end{pmatrix}.$$

Direct calculation gives $H(b_0) = 0.307$, $H(b_1) = 0.286$, $H(b_2) = 0.328$, $I(b_1; b_2) = 0.040$ and $I(b_0; b_1, b_2) = 0.138$. Thus we have the yield

$$D_h = 0.365,$$

through the original method while our improved method gives

$$D'_h = 0.543.$$

For this state, our method reduces not only the number of rounds for identifying the pattern of amplitude bits (from $H(b_2) = 0.328$ in the original method to $H(b_2|b_1) = 0.288$), but also the number of rounds for identifying the pattern of phase bit (from $H(b_0) = 0.307$ in the original method to $H(b_0|(b_1, b_2)) = 0.169$).

H. Recurrence method for GHZ state distillation (Murao et al's method)

Hashing protocols are particularly useful at low noise level because they have rather high yields. However, hashing protocols generally can tolerate rather low noise levels. That is to say, the threshold value of the fidelity above which hashing protocols will work is rather high. Fortunately, another class of protocols—recurrence protocols—enjoys a lower threshold value for fidelity.

We will now describe recurrence protocols. Our idea works for a general N -partite case. However, for concreteness, we will focus on the tri-partite case. In Murao et al's paper [4], two steps called P1 and P2 are used alternately. The P1 and P2 steps are shown in Fig. 3. In P1, the three parties first randomly permute their trios of qubits. Consider now a random pair of trios of qubits shared by Alice, Bob and Charlie. Each party has a pair of qubits in his/her hand. He/she measures $X_1 X_2$ and broadcasts the outcome. They then keep the first trio of qubits if there are an even number of -1 outcomes. Otherwise, they throw away the two trios of qubits altogether. Similarly, in P2, each party takes a pair of qubits as the input and measures $Z_1 Z_2$ and broadcasts the outcome. They then keep the first trio of qubits if all parties get the same measurement outcome. Otherwise, they throw away the two trios of qubits altogether.

We remark that the subroutine P1 checks the parity check condition, $XXX = +1$, and the subroutine P2 checks the parity check conditions, $ZZI = +1$ and $ZIZ = +1$.

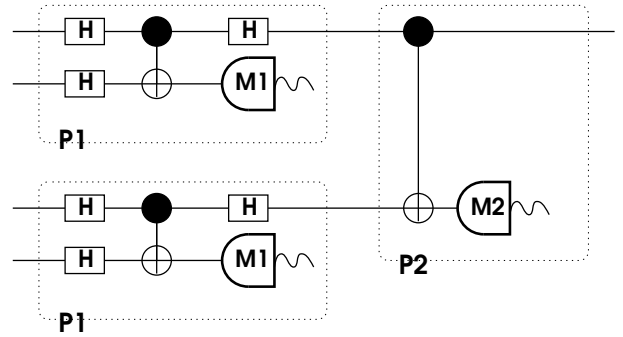

Fig. 3. Purification protocol P1+P2 used in Murao et al's paper [4]

They showed that one can obtain perfect GHZ states by P1+P2 iteratively whenever $F \geq 0.4073$. In fact, one can obtain better bounds to give $F \geq 0.3483$ by applying P2+P1 iteratively. It is proved in [6] that one can distill GHZ state whenever $F > 0.3$ by applying a different distillation protocol. Also Dür and Cirac verified in [6] numerically that one can also distill GHZ state whenever $F > 0.3$ by a modified version of Murao et al's protocol [4], which involves a state-dependent sequence of P1 and P2 steps. We remark that, however, there is no easy way to figure out the state-dependent sequence of steps for an ensemble of states with specific initial fidelity F . The result is also compatible with the theoretical limit of $F > 0.3$ which is given by the PPT criterion [23], [24] for the Werner-like states [5], [6].

Let us now explain Murao et al's protocol [4] in the modern stabilizer formulation: In fact, their protocol is to apply post-selections based on bit-flip error syndromes and phase-flip error syndromes separately. The P2 step corresponds to a bit-flip error syndrome measurement followed by post-selection, while the P1 step corresponds to phase-flip error syndrome measurement followed by post-selection. Here the stabilizer for the GHZ state is CSS-like and errors can be corrected by two steps together. We call a distillation procedure to be CSS-based distillation if all the measurement operators used are of either X -type or Z -type. Murao et al's protocol is thus a CSS-based GHZ state distillation.

Remark 5: Recurrence protocols have asymptotically zero yields when the required fidelity go to one. This is because after P1 or P2 step, the residual states may have a higher fidelity but losing at least one half of the states. Thus the yield for the recurrence protocol is zero in the asymptotic sense. Therefore, at a high noise level, one should start with a number of rounds of the recurrence protocol and switch to a hashing protocol when the hashing protocol starts to work. For this reason, it is important to study both hashing and recurrence protocols.

III. CSS STATES

In this section, we generalize our results on the GHZ state to a general CSS state. We first define a CSS state and show

that, just like the GHZ state, a CSS state can be distilled by the various aforementioned protocols (recurrence and hashing). We derive the yield for the hashing protocol. Finally, we show that a CSS state is equivalent to a bipartite (i.e., two-colorable) graph state, a subject of recent attention.

A. Distillation of CSS-states

A CSS-state is basically a CSS-code [25], [26] where the number of encoded qubits is zero. For instance, an encoded $|0\rangle$ state of a CSS code is a CSS-state. More formally, we have the following definition.

Definition: CSS states. A CSS-state is a $+1$ eigenstate of a complete set of (commuting) stabilizer generators such that each stabilizer element is of X-type or Z-type only.

Example: A GHZ-state is a CSS-state with stabilizer generators XXX , ZZI and ZIZ .

Claim 1: Consider the distillation of a multi-partite CSS-state, given N noisy versions of such a state. Consider a complete set of CSS generators (i.e., each of X-type or Z-type). Suppose we label its simultaneous eigenstate by its simultaneous eigenvalues $|\hat{b}, \hat{p}\rangle$ where $\hat{b} = \{b_1, b_2, \dots, b_m\}$ is a vector that denotes the tuples of Z-type eigenvalues and $\hat{p} = \{p_1, p_2, \dots, p_n\}$ is a vector that denotes the tuples of X-type eigenvalues. Consider a pair of multi-partite states. We claim that, under multilateral quantum XOR gates (MXOR), the state of the pair evolves as follows

$$\text{MXOR} \left[|\hat{b}^1, \hat{p}^1\rangle |\hat{b}^2, \hat{p}^2\rangle \right] = |\hat{b}^1, \hat{p}^1 + \hat{p}^2\rangle |\hat{b}^1 + \hat{b}^2, \hat{p}^2\rangle. \quad (16)$$

That is to say, that the bit-flip errors propagate forward and the phase errors propagate backwards.

Claim 1 follows from a standard result in quantum error correction. It is easy to understand from the evolution of Pauli operators acting on individual qubits. We will skip its proof here.

The upshot of Claim 1 is that much of what we learn from GHZ can be directly generalized to a general multi-partite CSS-state. For instance, we can apply the hashing protocols and sub-routines P1 and P2 to a general CSS state. In what follows, we will discuss this point in more detail.

By using random hashing (in Z and followed by in X), one can easily show that the yield is

$$D_h > 1 - \max_i [H(b_i)] - \max_j [H(p_j)], \quad (17)$$

where the maximum over i is over all bit-flip eigenvalues, b_i , and the maximum over j is over all phase eigenvalues, p_j .

As in the case of GHZ, we can apply the trick in [18] to improve the result to

$$D_h > 1 - \max_i [H(b_i)] - \max_j [H(p_j|\hat{b})]. \quad (18)$$

This is so because the mutual information $I(\hat{b}, \hat{p})$ between the bit-flip and phase syndromes is non-zero. Therefore, learning the bit-flip error pattern allows one to reduce the entropy for the phase error pattern to the *conditional* entropy given the bit-flip error pattern.

Alternatively, one can hash in X first and then hash in Z. Therefore, we also have

$$D_h > 1 - \max_j [H(p_j)] - \max_i [H(b_i|\hat{p})]. \quad (19)$$

Combining the two results, we have

$$D_h > \max \left(1 - \max_i [H(b_i)] - \max_j [H(p_j|\hat{b})], \right. \\ \left. 1 - \max_j [H(p_j)] - \max_i [H(b_i|\hat{p})] \right). \quad (20)$$

As will be shown below, CSS-states are equivalent to bipartite states. Our hashing result (20) is an improvement over the prior art result in [7], [8].

In principle, for some states, we will be able to improve the result further. As an example, suppose \hat{b} consists of only b_1 and b_2 and $H(b_2) > H(b_1)$ and $I(b_2; b_1) > 0$. Then, we can improve the yield to

$$D'_h > \max \left(1 - \max \{H(b_1), H(b_2|b_1)\} - \max_j [H(p_j|\hat{b})], \right. \\ \left. 1 - \max_j [H(p_j)] - \max_i [H(b_i|\hat{p})] \right). \quad (21)$$

Here, by a similar argument to what we used before for a GHZ state, we make use of the non-trivial mutual information $I(b_2; b_1)$ between b_1 and b_2 to reduce the rounds of hashing needed.

We note that one can apply the subroutines P1 and P2 to any CSS-state. As in the case of GHZ, this will allow the successful distillation of CSS-state at higher error rates than what is possible with only a hashing protocol.

IV. EQUIVALENCE OF CSS-STATES AND BIPARTITE GRAPH STATES

Distillation of another type of states, so-called graph states, have also been discussed in the literature. In particular, Dür, Aschauer, and Briegel [8] have recently found systematic procedures for distilling a special class of graph states—those that are bipartite (i.e., 2-colorable). In what follows, we will describe bipartite graph states and show that they are essentially equivalent to CSS-states. An undirected graph is specified by a set of vertices, V and edges, E . A graph is said to be bipartite (i.e., 2-colorable) if the set of vertices can be decomposed into two sets, say L (left) and R (right) such that an edge is only allowed to connect a L vertex with a R vertex (but not between two L (or R) vertices).

A graph state is a multi-partite state where each vertex, v_j , represents a qubit. A graph state has stabilizer generators of the form $K_j = X_j \prod_{(j,k) \in E} Z_k$.

One part (Part B) of the following Claim is due to Eric Rains.

Claim 2: Bipartite (i.e, two-colorable) graph states are equivalent to CSS-states. (Since the concepts of bipartite/two-colorable and CSS are *not* invariant under local unitary transformations, one has to be careful in stating the claim. More precisely, Claim 2 says that any state that can be represented by a bipartite/two-colorable graph state can be written as a CSS-state and vice versa.)

Proof: (Part A: Bipartite implies CSS.) Given a bipartite graph state. Let us consider the following operation. We apply a Hadamard transformation to all “left” vertices and the identity operator to all “right” vertices. Now, for any left vertex, v_j , the associated stabilizer generator becomes Z -type (because $X_j \rightarrow Z_j$ and any vertex v_k connected to v_j is a right vertex and so $Z_k \rightarrow Z_k$). On the other hand, for any right v_j , the associated stabilizer generator becomes X -type (because now $X_j \rightarrow X_j$ itself and $Z_k \rightarrow X_k$, as v_k , being connected to v_j , must be a left vertex).

(Part B: CSS implies bipartite. The result is due to Eric Rains.) Given a CSS-state. Consider the associated classical code, C . Its parity check matrix in canonical form is $H_C = [I|A]$ where I is say a k by k matrix and A , a k by $n - k$ by matrix. Now, the parity check matrix for its dual code, C^\perp , is given by $H_{C^\perp} = [A^T|I]$ where A^T is an $n - k$ by k matrix and I an $n - k$ by $n - k$ matrix. Note that a CSS-state has a complete set of stabilizer generators. This implies that the parity check matrix of a CSS-state must be of the form

$$\begin{aligned} H &= \begin{pmatrix} H_C & 0 \\ 0 & H_C^\perp \end{pmatrix} \\ &= \begin{pmatrix} I & A & 0 & 0 \\ 0 & 0 & A^T & I \end{pmatrix}. \end{aligned} \quad (22)$$

We now apply Hadamard transforms on the last $n - k$ qubits. This will inter-change between X and Z , thus mapping the parity check matrix to be

$$H = \begin{pmatrix} I & 0 & 0 & A \\ 0 & I & A^T & 0 \end{pmatrix}. \quad (23)$$

Notice that the above parity check matrix indeed represents a bi-partite graph. Let us regard the first k qubits as left vertices and the remaining $n - k$ qubits as right vertices. Note that there is indeed no edge between vertices on the same side. And, A represents the adjacent matrix of the graph. Q.E.D.

Claim 2 establishes the equivalence of two different mathematical formulations: CSS-states and bipartite graph states. It means that much of what we have learnt about the distillation of bipartite/two-colorable graph states through the work of Dür, Aschauer, and Briegel [8] can be interpreted in the more systematic formulation of CSS-states. In particular, it is natural to consider the bit-flip and phase error patterns separately and consider their propagations in quantum computational circuit. From Claim 2, we learn that Claim 1, which originally refers to CSS states, can be applied directly to any bipartite graph states. Moreover, the improvement that we have found in (21) over (17), in fact, applies to bipartite graph states. Notice that the basic primitives in our protocol are the same as in [8]. However, the numbers of rounds that one needs to apply those basic primitives are smaller in our analysis than in [8]. Our analysis also gives a non-zero yield by combining the recurrence protocol with a hashing protocol. In contrast, the yield in [8] will go to zero when the required fidelity go to one.

A. Distillation of non-CSS states

So far, our discussion has focussed on CSS-states (i.e., 2-colorable graph states). It will, thus, be interesting to investigate the distillation of non-CSS-states. We believe that this is a highly non-trivial question for the following reasons.

First of all, as noted earlier, whether a state is in a CSS form or not is not invariant under local unitary transformations. For this reason, given a general stabilizer state, there is no known efficient algorithm to determine whether it can be realized as a CSS-state. Second, when a state is known to be non-CSS, it is highly unclear what the basic primitives for distillation should be.

However, one possible approach—cut and re-connect—has already been discussed in [8], [9]. Their idea is by performing some local measurements, the parties can *cut* a graph state into a sub-graph state. Suppose one is given $2N$ copies of some noisy version of a non-bipartite graph states. One might imagine cutting N copies in a specific way to generate some sub-graph that is bipartite (and, therefore, CSS-like). They can then distill this CSS sub-graph state. They also cut the other N copies in another way to generate another sub-graph that is bipartite. They can then distill this other CSS sub-graph state. Afterwards, they can re-connect these two subgraphs by performing some (say Bell-type) measurements. More generally, they can apply this cut-and-reconnect strategy iteratively. The extreme case of this strategy is to cut everything into EPR-pair states. One then distills only bi-partite EPR pair states and re-connect them by teleportation. In our opinion, it will be interesting to study this cut and re-connect strategy in more detail.

Recently, the distillation of W-state (a non-CSS state) has been discussed in [27]

V. MULTI-PARTY QUANTUM CRYPTOGRAPHY

A. Adversarial Model

The key simplifying assumption we make here is that, at least in the first phase of the protocol, the three participating parties, Alice, Bob, and Charlie, will always perform their tasks honestly. The case where some of the participants may be dishonest even in the first phase of the protocol is an interesting subject that deserves future investigations.

What threats are we trying to address here? We consider an eavesdropper, Eve, who may actively tamper with quantum channels and also passively monitor all classical communications. Our goal is to prevent Eve from learning secrets in the protocol. In the second phase of the protocol, some of the participants are allowed to be dishonest.

In summary, Eve is active, and is collaborating with Bob (or Charlie), who only cheats “passively” (i.e., honest but curious).

So, what multi-party cryptographic tasks do we consider? We will consider three tasks, namely (a) conference key agreement, (b) quantum sharing of classical secrets and (c) third-man cryptography.

B. Conference Key Agreement

A well-known problem in classical cryptography is secret broadcasting and conference key agreement [17]. Suppose

Alice would like to broadcast a message securely to only Bob and Charlie, in the presence of an eavesdropper, Eve. One simple method to achieve it is for Alice, Bob and Charlie to first share a common conference key, k . Then, Alice can use the key, k , as a one-time-pad for encrypting her message.

The goal of conference key agreement is precisely for three parties, Alice, Bob, and Charlie, to obtain a common random string of numbers, known as the conference key, k , and to ensure that k is secure from any eavesdropper, Eve. Consider the following scenario: Alice, Bob and Charlie initially share some quantum states that either are prepared by Eve or are prepared by Alice, but have to go through Eve's channels before reaching Bob and Charlie. We will specialize to "prepare-and-measure" type of protocols, mentioned in our introduction.

To secure their classical communications, we assume that each pair of the three parties, Alice, Bob and Charlie, also share a pairwise authenticated classical channel. This can be achieved by requiring that they share a small amount (logarithmic in the amount of classical communications) of authentication key. For simplicity, we will assume perfect authentication. Besides tampering with quantum channels, Eve can listen to all classical communications passively.

Since Alice, Bob and Charlie are in the same boat, we think it is fair to assume that they will always execute the protocol honestly.

C. Quantum Sharing of Classical Secrets

The second protocol is the quantum sharing of classical secrets [10], which has been demonstrated experimentally in a recent experiment [14]. Whereas Ref. [10] deals with perfect GHZ states, we consider noisy GHZ states. Suppose a President, Alice (A), has the password for a bank vault and he would like to divide up this secret password between two Vice Presidents, Bob (B) and Charles (C), in such a way that neither B nor C alone knows anything about the password and yet when B and C come together, they can re-generate the password. Suppose further that A, B and C live very far away from each other. An eavesdropper, Eve may try to intercept the communications during the secret sharing phase.

Here, we make a rather strong assumption that in the distribution and verification phase of the quantum signals, the three parties—A, B, and C—are trustworthy. However, an adversary, Eve, can tamper with quantum channels. Besides, Eve may eavesdrop passively on all classical communications during the verification step.

Phase One (Distribution and verification phase): In the first phase of the protocol, the three parties (trusted for the moment) use quantum states to perform the sharing of binary correlations, X_A , X_B and X_C satisfying

$$X_A \oplus X_B \oplus X_C = 0, \quad (24)$$

between them. Alice, Bob and Charlie perform local, individual measurements on qubits and also classical computations and classical communications between each other. We assume that all classical communications are authenticated by standard unconditionally secure method of authentication. Finally,

either Alice, Bob and Charlie abort the protocol or they have the confidence that they have shared those correlations.

Phase Two (Broadcast Phase): Suppose Alice would like to share a secret bit a with Bob and Charles. We assume Alice has a broadcast channel. Alice broadcasts $b = a \oplus X_A$. Note that if Bob and Charles get together, they can compute $X_B \oplus X_C$ and thus, $b \oplus X_B \oplus X_C = a \oplus X_A \oplus X_B \oplus X_C = a$. Therefore, Bob and Charles can recover the secret a , if they come together. However, neither Bob or Charles on his own has any information at all about the bit, a . In summary, Alice, Bob and Charlie, have achieved sharing of classical secrets.

In summary, the goal of quantum sharing of classical secrets is to ensure that an eavesdropper Eve cannot learn about the shared secrets. We assume that Alice, Bob and Charles, are trustworthy in Phase One of the protocol.

D. Third-Man Cryptography

Our quantum secret sharing protocol can be modified into a "third-man cryptography" protocol. This will be discussed in Subsection VII-C

VI. 3-PARTY CONFERENCE KEY AGREEMENT WITH NOISY GHZ STATES

In this section, we apply the ideas of multi-partite entanglement distillation to a conference key agreement scheme. We consider a prepare-and-measure protocol where a preparer distributes n trios of qubits to the three parties.

Note that, if one of the parties, say Alice, is actually the preparer of the multi-partite state, in a prepare-and-measure protocol, she is allowed to pre-measure her subsystem. By doing so, she has projected an N -partite entangled state into one of the various $(N - 1)$ -partite entangled state. Therefore, the protocol can be implemented with only $(N - 1)$ -party entanglement. The above conversion idea is similar to the idea in [12] and [11].

How do we prove the security of our prepare-and-measure protocol? We start with a CSS-based GHZ state distillation protocol and try to convert it to a "prepare and measure" protocol. We draw our inspiration from [12], [11] where security of BB84 is proven by conversion from an entanglement distillation protocol (EDP). Specifically, Ref. [11] shows that for an EDP to be converted to a prepare-and-measure protocol (namely, BB84), it can include bit-flip error syndrome measurement and post-selection as well as phase error syndrome measurement. However, following the discussion in [11], the post-selection of surviving systems based on phase error syndromes is strictly forbidden, if an EDP is convertible to BB84. This is because, without a full-blown quantum computer, it is impossible for a participant to hold measurement outcomes simultaneously in two different bases (bit-flip and phase) for individual qubits. Without those measurement outcomes, a participant cannot know what *conditional* or *post-selected* actions to take for bit-flip and phase error detections simultaneously.

Let us first look at the original protocol by Murao et al [4]. The P2 step can be considered as a bit-flip error syndrome measurement and post-selection step and as such it is allowed

in a prepare-and-measure protocol. Then, the P1 step, which involves post-selection based on phase error syndromes, is strictly forbidden in a “prepare-and-measure” protocol [11]. Therefore, Murao et al’s protocol cannot be converted to a “prepare and measure” protocol. This is why we have to search for a new primitive.

Let us construct some subprotocols. For bit-flip error detection (B step), we use the same procedure as the P2 step of Murao et al [4] as shown in Fig. 4. As for phase error correction (P step), we design a procedure using the idea of Gottesman and Lo [11] as shown in Fig. 5, but apply it to the multi-partite case.

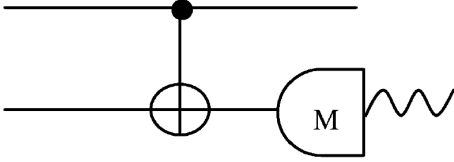

Fig. 4. B step (bit-flip error detection) procedure for conference key agreement protocol

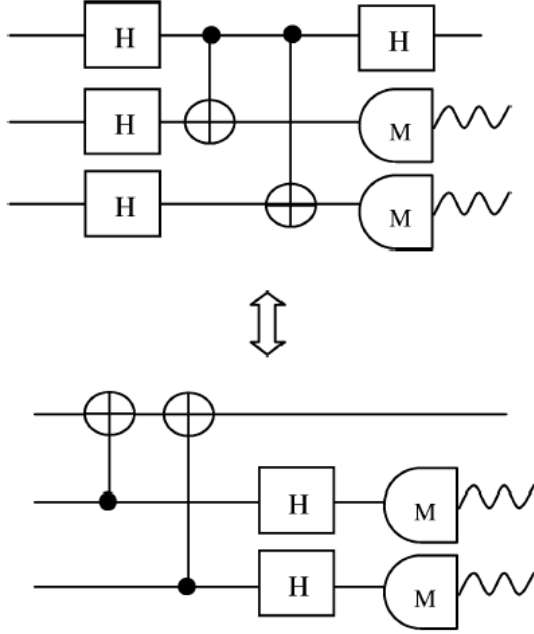

Fig. 5. P step (phase-flip error correction) procedure for conference key agreement protocol. In a prepare-and-measure protocol for conference key agreement, each of Alice, Bob and Charlie simply takes the parity $(Z_A + Z_B + Z_C) \bmod 2$ of their own three particles, which can be done locally and no classical communication is needed.

Our multi-partite B step: Using the formulation of stabilizer, this step can be reformulated by the following transformation of the two GHZ-like states

$$\begin{aligned} & [(p, i_1, i_2), (q, j_1, j_2)] \\ & \xrightarrow{\text{applying BXOR}} (p \oplus q, i_1, i_2), (q, i_1 \oplus j_1, i_2 \oplus j_2), \end{aligned} \quad (25)$$

where $(p, i_1, i_2), (q, j_1, j_2)$ denote the phase bit and amplitude bits for the first and second GHZ-like states. If $i_1 \oplus j_1 =$

$i_2 \oplus j_2 = 0 \pmod 2$, we keep the first GHZ state, otherwise discard all the two states. In a prepare-and-measure conference key agreement protocol, this corresponds to the prescription that we keep the first trio iff $M_A = M_B$ and $M_A = M_C$ (i.e., Alice, Bob and Charlie get the same measurement outcome). This step changes the 8 elements of diagonal entries $(p_{000}, p_{100}, p_{011}, p_{111}, p_{010}, p_{110}, p_{001}, p_{101})^t$ to

$$\begin{pmatrix} p_{000}^2 + p_{100}^2 \\ 2p_{000}p_{100} \\ p_{011}^2 + p_{111}^2 \\ 2p_{011}p_{111} \\ p_{010}^2 + p_{110}^2 \\ 2p_{010}p_{110} \\ p_{001}^2 + p_{101}^2 \\ 2p_{001}p_{101} \end{pmatrix} / P_{pass}, \quad (26)$$

where $P_{pass} = ((p_{000} + p_{100})^2 + (p_{001} + p_{101})^2 + (p_{010} + p_{110})^2 + (p_{011} + p_{111})^2)$ is the probability for the survived subset.

Our multi-partite P step: Using the formulation of stabilizer, this step (shown in Fig. 5) can be reformulated by the following transformation of the three GHZ-like states

$$\begin{aligned} & [(p, i_1, i_2), (q, j_1, j_2), (r, k_1, k_2)] \\ & \xrightarrow{\text{applying 1st BXOR}} [(p, i_1 \oplus j_1, i_2 \oplus j_2), (p \oplus q, j_1, j_2), (r, k_1, k_2)] \\ & \xrightarrow{\text{applying 2nd BXOR}} [(p, i_1 \oplus j_1 \oplus k_1, i_2 \oplus j_2 \oplus k_2), (p \oplus q, j_1, j_2), (p \oplus r, k_1, k_2)] \end{aligned} \quad (27)$$

If $p \oplus q = p \oplus r = 1 \pmod 2$, we apply $p \rightarrow p \oplus 1 \pmod 2$, otherwise keep the first GHZ-like state invariant. Note that P can also be performed locally by each party, which regards the circuit as implementing a 3-qubit phase error correction code. The important point to note is that no post-selection on surviving systems is needed in our multi-partite P step.

Here the condition exactly corresponds to the fact that, if an odd number of the source bits are measured to be in the same state $|1\rangle$ both in the second and in the third GHZ-like states, we just apply a Z operation in Alice’s qubit for the first GHZ-like states. Otherwise, just keep the first GHZ-like state invariant. The same as for the B step, to obtain the density matrix after the P step, one just needs to count and sum all the probability for the residual state according to Eq. (27). For example, if the three initial quantum states in Fig. 5 are in $(p, i_1, i_2), (q, j_1, j_2), (r, k_1, k_2)$ with probabilities of $p_{p,i_1,i_2}, p_{q,j_1,j_2}, p_{r,k_1,k_2}$, respectively, then the final state will be $(p, i_1 \oplus j_1 \oplus k_1, i_2 \oplus j_2 \oplus k_2)$ with probability $p_{p,i_1,i_2} p_{q,j_1,j_2} p_{r,k_1,k_2}$. Sum all the possibilities for such combinations (in our case, one has $8 \times 8 \times 8 = 512$ different probabilities combinations for three initial quantum states), one arrives a final GHZ-diagonal state, which we skip the verbose expression here.

A. Conversion to a prepare-and-measure protocol

We now argue that the aforementioned entanglement distillation subprotocol (P step) can be converted to a prepare-and-measure protocol for conference key agreement. This is in the

spirit of [11]. Recall that in a prepare-and-measure protocol, the three parties, Alice, Bob and Charlie, are presented with an ensemble of noisy GHZ states. They perform local measurements on individual qubits and then classically compute and classically communicate with each other. Their goal is to share a common string of random number between the three parties so that an eavesdropper will have an negligible amount of information on it. Such a common secret random number can then be used as a key for a conference call between the three parties.

In the entanglement distillation picture, for conference key agreement, Alice, Bob and Charlie do not need to perform phase error correction. They only need to prove that, phase error correction would have been successful, if they had performed it. In a prepare-and-measure protocol for conference key agreement, by the second part of Fig. 5, each of Alice, Bob and Charlie simply takes the parity $(Z_1 + Z_2 + Z_3) \bmod 2$ of their own three particles. In other words, each computes locally the parity of his/her three measurement outcomes. No classical communication is needed. This has been discussed in [11].

Moreover, following [11], we can apply the same conversion idea to any concatenated protocols involving B steps, P steps and following by a hashing protocol. This conversion result means that we can obtain secure protocols for conference key agreement by considering the convergence of GHZ distillation protocols involving those operations.

In what follows, we consider only Werner-like states. By direct numerical calculation, we can verify that our scheme can distill GHZ states with nonzero yield whenever $F \geq 0.3976$ by some state-dependent sequence of B and P steps, and then change to our random hashing method if it works. We find that a sequence of B and P steps BBBB for $F = 0.3976$, which is optimal for any sequence with at most 5 steps (consisting of only B or P) plus immediate random hashing. Compared with the random hashing method of Maneva and Smolin which works only when $F \geq 0.8075$ and our improved random hashing method which works only when $F \geq 0.7554$, our new protocol gives dramatic improvement by using 2-way classical communications. We just execute some state-dependent sequence of B and P steps, and then change to the hashing method once the effective error rate has decreased to the point where our improved hashing method actually works. These results imply that Alice, Bob and Charlie can achieve secure conference key agreement if they share a generalized Werner state with a fidelity $F \geq 0.3976$. It should be remarked that the sequence BBBB works only for Werner state with initial fidelity around 0.3976. A different initial fidelity requires a different optimal sequence plus immediately random hashing. Also a different sequence length causes different optimal sequence. Similar to the case of distilling directly GHZ state using P1 and P2 steps shown in [6], there is no easy way to derive an optimal sequence as well for our protocols. However, we remark that in practice 5 steps of P and B combinations is reasonable sequence length and is easy to be optimized with a standard computer by a simple program. The three parties just need to estimate reliably the shared GHZ-basis diagonal states (after depolarization procedure in

Section II.C) and then obtain an optimal sequence for them by performing the computer search. Then the three parties execute B step by CCCC. Whenever there is a P step, they take the parity $(Z_1 + Z_2 + Z_3) \bmod 2$ of their own three particles locally. No classical communication is needed for a P step. Even when the shared GHZ-basis diagonal state is not a Werner state, the same analysis can be applied to obtain some optimal sequence of B and P steps combining with our hashing method and see if one can succeed to make conference key agreement.

B. Experimental Implementations

For practical implementations, we remark that, if one of the parties, say Alice, is the preparer of the state, then in a prepare-and-measure protocol she has the option to pre-measure her subsystem. By doing so, she has converted a protocol that involves N -party entanglement to one that involves only $(N - 1)$ -party entanglement.

Consider the case when $N = 3$. The above discussion means that three-party conference key agreement can be implemented with only bi-partite entangled states. More concretely, imagine that Alice prepares a perfect GHZ state and measures her qubit along the Z -axis. After her measurement, Bob and Charlie's state is in either $|00\rangle$ or $|11\rangle$ (with equal probabilities). Similarly, suppose Alice measures her qubit along the X -axis. After her measurement, Bob and Charlie's state is in either $1/\sqrt{2}(|00\rangle + |11\rangle)$ or $1/\sqrt{2}(|00\rangle - |11\rangle)$ (with equal probabilities). Similarly, suppose Alice measures her qubit along the Y -axis. After her measurement, Bob and Charlie's state is in either $1/\sqrt{2}(|00\rangle + i|11\rangle)$ or $1/\sqrt{2}(|00\rangle - i|11\rangle)$ (with equal probabilities).

In summary, Alice could implement conference key agreement by simply preparing one of the six states $|00\rangle$, $|11\rangle$, $1/\sqrt{2}(|00\rangle + |11\rangle)$, $1/\sqrt{2}(|00\rangle - |11\rangle)$, $1/\sqrt{2}(|00\rangle + i|11\rangle)$, or $1/\sqrt{2}(|00\rangle - i|11\rangle)$ and sending the two qubits to Bob and Charlie respectively through some quantum channels. Notice that the six states listed above only involve bi-partite entanglement and as such can be readily prepared by parametric down conversion sources. For this reason, it is feasible to demonstrate experimentally our conference key agreement scheme.

While we have focussed our discussion on the three-party case, we remark that the basic concepts apply directly to the $N > 3$ -party case. Moreover, a prepare-and-measure protocol involving N -parties can be implemented with $(N - 1)$ -partite entanglement. We shall skip the details here.

VII. SECRET SHARING IN A NOISY CHANNEL

A. Quantum Secret Sharing

In a classical secret sharing scheme, some sensitive data is divided up into shares among a number of people so that it can be re-constructed if and only if a sufficiently large number of people get together. For instance, in a classical (k, n) -threshold scheme, the secret is divided among n parties such that when k or more parties get together, they can re-construct the secret. On the other hand, if less than $k - 1$ parties get together, then they have absolutely no information on the secret.

The idea of (k, n) -threshold quantum secret sharing scheme was first proposed in [28]: A preparer presents the dealer with an unknown quantum state. The dealer then divides up the unknown state among n parties. The quantum no-cloning theorem demands that $2k > n$ for the existence of a (k, n) -threshold quantum secret sharing scheme. This is the only requirement for the existence of a quantum secret sharing scheme.

It was then shown in [29] that for any access structure that does not violate the quantum no-cloning theorem, a quantum secret sharing scheme exists. We remark the construction in [28], [29] makes use of CSS codes.

B. Quantum sharing of classical secrets

Another related concept—quantum sharing of classical secrets—has also been introduced [10]. Here, the goal is to use quantum states to share a *classical* secret between multiple parties and to ensure that no eavesdropper can learn useful information by passive eavesdropping. It has been shown [10] that in the absence of noises, one can construct a secure secret sharing scheme using perfect GHZ state by just measuring *along X basis* between Alice, and cooperating Bob and Charlie. The key point is that the GHZ state is a $+1$ eigenstate of XXX . So, by measuring the X -basis, Alice, Bob and Charlie's measurement outcomes will satisfy a classical constraint of $X_A + X_B + X_C = 0 \pmod 2$. Note that individually, each of Bob and Charlie has no information on X_A . But, by getting together, Bob and Charlie can obtain $X_B + X_C \pmod 2$ and, therefore, obtain X_A . Suppose Alice now would like to share a bit value, b , with Bob and Charlie. She can broadcast $X_A + b$.

Now, let us consider the case of noisy GHZ states. We want to develop a GHZ distillation protocol which can be converted to a “prepare and measure” secret sharing scheme. Such a scheme is technologically less challenging than a full-blown quantum computing scheme and yet one can analyze its security by using our ideas for GHZ distillation protocols presented in this paper.

Note that, since the final measurement is now done along the X -axis, the bit-flip measurements now correspond to measurements along X . The readers should bear this point in mind to avoid any future confusion. Therefore, for the bit-flip error detection code (B' step), we use the same procedure as the P1 step of Murao et al [4] as shown in Fig. 6. As for the phase error correction (P' step), we design a procedure similar to the idea of Gottesman and Lo [11] as shown in Fig. 7.

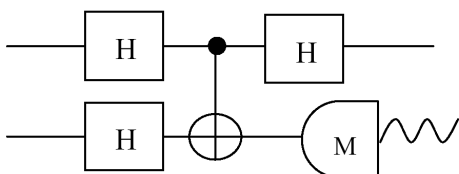

Fig. 6. B' step (bit-flip error detection) procedure for secret sharing

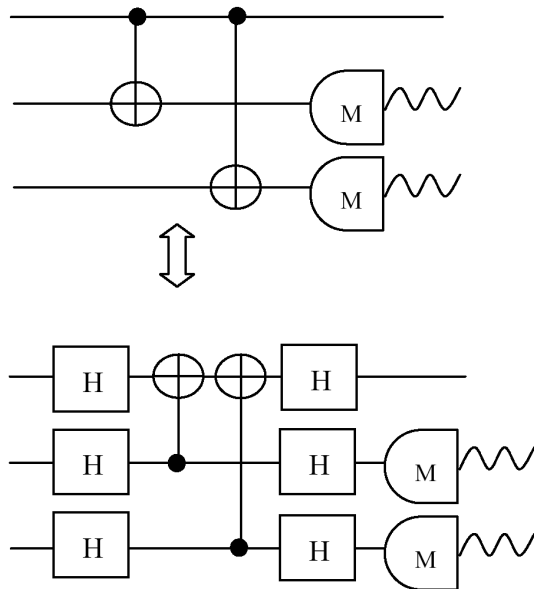

Fig. 7. P' step (phase-flip error correction) procedure for secret sharing. In a prepare-and-measure protocol for secret sharing, each of Alice, Bob and Charlie simply takes the parity $(X_A + X_B + X_C) \pmod 2$ of their own three particles, which can be done locally and no classical communication is needed.

Our P' step for secret sharing: Using the formulation of stabilizer, this step (shown in Fig. 7) can be reformulated by the following transformation of the three GHZ-like states

$$\begin{aligned}
 & [(p, i_1, i_2), (q, j_1, j_2), (r, k_1, k_2)] \\
 & \xrightarrow{\text{applying 1st BXOR}} [(p \oplus q, i_1, i_2), (q, i_1 \oplus j_1, i_2 \oplus j_2), (r, k_1, k_2)] \\
 & \xrightarrow{\text{applying 2nd BXOR}} [(p \oplus q \oplus r, i_1, i_2), (q, i_1 \oplus j_1, i_2 \oplus j_2), (r, i_1 \oplus k_1, i_2 \oplus k_2)] \\
 & \tag{28}
 \end{aligned}$$

If $i_1 \oplus j_1 = i_1 \oplus k_1 = 1 \pmod 2$, we apply $i_1 \rightarrow i_1 \oplus 1 \pmod 2$. If $i_2 \oplus j_2 = i_2 \oplus k_2 = 1 \pmod 2$, we apply $i_2 \rightarrow i_2 \oplus 1 \pmod 2$. Otherwise keep the first GHZ-like state invariant. Note that the phase error correction procedure can be performed locally by each party because the circuit diagram in Fig. 7 is simply a simple three-qubit majority vote code. The condition exactly corresponds to the fact that, if Alice's and Bob's measurement outcomes disagree for both the second and the third GHZ-like states, we just apply a X operation in Bob's qubit for the first GHZ-like states, and that, if Alice's and Charlie's measurement outcomes disagree for both the second and the third GHZ states, we just apply a X operation in Charlie's qubit for the first GHZ-like states. Otherwise, just keep the first GHZ-like state invariant. Follow the similar counting procedure as done for the P step of conference key agreement, one can know the final states exactly by straightforward calculation according to Eq. (28).

We will now argue that this phase correction protocol can be converted to a “prepare-and-measure” protocol for quantum secret sharing. In a prepare-and-measure protocol for secret sharing, each party simply computes the parity of his/her own three measurement outcomes locally. No classical communication is needed.

Our B' step for secret sharing: Again using the formulation of stabilizer, this step (shown in Fig. 6) can be reformulated by the following transformation of the two GHZ-like states

$$[(p, i_1, i_2), (q, j_1, j_2)] \xrightarrow{\text{applying BXOR}} (p, i_1 \oplus j_1, i_2 \oplus j_2), (p \oplus q, j_1, j_2), \quad (29)$$

If $p \oplus q = 0 \pmod{2}$, we keep the first GHZ-like state, otherwise discard all the two states. This step changes the 8 elements of diagonal entries $(p_{000}, p_{100}, p_{011}, p_{111}, p_{010}, p_{110}, p_{001}, p_{101})^t$ to

$$\begin{pmatrix} p_{000}^2 + p_{001}^2 + p_{010}^2 + p_{011}^2 \\ p_{100}^2 + p_{101}^2 + p_{110}^2 + p_{111}^2 \\ 2(p_{001}p_{010} + p_{000}p_{011}) \\ 2(p_{101}p_{110} + p_{100}p_{111}) \\ 2(p_{000}p_{010} + p_{001}p_{011}) \\ 2(p_{100}p_{110} + p_{101}p_{111}) \\ 2(p_{000}p_{001} + p_{010}p_{011}) \\ 2(p_{100}p_{101} + p_{110}p_{111}) \end{pmatrix} / P_{pass}, \quad (30)$$

where $P_{pass} = (p_{000} + p_{001} + p_{010} + p_{011})^2 + (p_{100} + p_{101} + p_{110} + p_{111})^2$ is the probability for the survived subset.

We argue that this subprotocol can be converted to a prepare-and-measure subprotocol for secret sharing. In the converted subprotocol, if $M_A \oplus M_B \oplus M_C = 0 \pmod{2}$, the three parties keep the first trio. Otherwise, they discard both trios.

The same conversion idea to a prepare-and-measure protocol also applies to a concatenated protocol involving B' steps, P' steps and random hashing. Therefore, to study the security of a secret sharing protocol, we can go back to the GHZ distillation picture and simply study the convergence of a GHZ distillation protocol involving B', P' and random hashing. In what follows, we consider only Werner-like states. By direct numerical calculation, we can verify that our scheme used in secret sharing in a noisy channel can distill GHZ states with nonzero yield whenever $F \geq 0.5372$ by some state-dependent sequence of B and P steps and then change to our random hashing method if it works. For the optimal sequences within 5 steps, we find it is (B'B'B'B'B') that just gives $F \geq 0.5372$ followed by hashing method. Compared with QKD scheme in a noisy channel, this lead to more entanglement requirement for secret sharing than the QKD scheme ($F \geq 0.3976$) by using our decoding scheme. Similar to the case of conference key agreement, the optimal sequences is for Werner state with initial fidelity around 0.5372. Different initial fidelity requires different optimal sequence plus immediately random hashing. After estimate reliably the shared GHZ-basis diagonal states calculate an optimal sequence, the three parties execute B' step by CCCC. Whenever there is a P' step, they take the parity $(X_A + X_B + X_C) \pmod{2}$ of their own three particles locally. No classical communication is needed. While we have only applied our protocol to Werner-like states, non-Werner-like states can be analyzed in a similar manner.

As in the case of conference key agreement, our protocol for three-party secret sharing can be implemented by using only bi-partite entanglement. The conversion is done by Alice

pre-measuring her subsystem. As a result, she only needs to prepare some bi-partite entangled states and send them to Alice and Bob.

As noted in the Introduction, in the above discussion, we have assumed that the three parties are honest in executing the protocol. While this may be a good assumption for conference key agreement, it may not be a good assumption for quantum sharing of classical secrets. In the latter protocol, whereas Alice may well be honest, the participants, Bob and Charlie, have incentives to cheat. We have not analyzed the question of how to make Bob and Charlie honest in detail. This is an important question that deserves future investigations. On the other hand, even in the case of classical secret sharing, one might imagine that Bob can cheat by claiming to hold a value that is different from what he actually holds. We are not aware of any simple solution even in this classical setting.

C. Third-Man Cryptography

We remark that a quantum sharing of classical secrets protocol can also be used to implement third-man cryptography. The goal of third-man cryptography is to allow a party, say Alice, as a central server, to control whether two other parties, Bob and Charles, can achieve secure key distribution. If Alice refuses to co-operate, Bob and Charles will fail to generate a secure key. On the other hand, if Alice says that she is willing to help, then Bob and Charles can verify that indeed they have managed generate a secure key, which is secret even from Alice! Starting from our conference key agreement protocol, Alice can simply broadcast all her measurement outcome Z_A . With the knowledge of Z_A , Bob and Charles should share some EPR states with each other. They can, therefore, proceed to check the purity of their EPR pairs in a similar manner as in standard BB84 and then proceed with classical post-processing (advantage distillation, error correction, and privacy amplification).

D. Experimental Implementations

Previous experimental implementations of both quantum sharing of classical secrets and third-man cryptography [14] required the simultaneous generation of two EPR pairs, which is extremely challenging, whereas our protocols, which assume that the preparer of the state is the central server, Alice, herself have the distinctive advantage of requiring the generation of only one EPR pair at a time. Our protocols, therefore, provide substantial simplifications and much higher yield, compared to previous experiment [14].

E. Application of multi-partite entanglement

It will be interesting to study secret sharing with a more general access structure [29], [30]. From an application standpoint, it will be particularly interesting to look into the possibility of converting those protocols to "prepare-and-measure" protocols where each party simply receives some noisy version of an entangled state from a source and then performs a measurement, followed by CCCCs.

VIII. SIGNIFICANCE OF OUR PROTOCOLS

A. Protocols with two-way classical communications are provably better than protocols with only one-way classical communications

In, for example, our three-party conference key agreement protocol, we allow Alice, Bob and Charlie to communicate back and forth with each other. By doing so, they can achieve secure conference key agreement for a Werner-like state whenever the fidelity $F \geq 0.3976$. One might wonder whether a two-way communication channel is generally needed between Alice and others during the conference key agreement stage. In other words, suppose Alice only has a broadcast channel to Bob and Charlie, but is not allowed to receive any classical communications in the conference key agreement stage. Starting with a Werner-like state of the same fidelity, can Alice, Bob and Charlie still distill a secure conference key?

As a comparison, for the BB84 quantum key distribution scheme, which is a two-party prepare-and-measure common key-agreement protocol, it is provably that protocols with two-way classical communications are better than those without. Indeed, in [11], BB84 with two-way classical communications is proven to be secure up to an error rate of 18.9 percent whereas any one-way protocol will be insecure whenever the bit error rate is larger than about 15 percent.

Returning to the three-party conference key agreement scheme, is the best one-way protocol as good as a two-way protocol? We now show directly that the answer is negative. In other words, we will prove that three-party conference key agreement protocols with two-way classical communications are provably better than those without. We do so by demonstrating that the tripartite Werner-like state (14) with fidelity $F = 6/19$ cannot be distilled into GHZs by any one-way protocols, but can be distilled by two-way protocols. Our argument is similar to one given in Ref. [3].

One way for a preparer Trent to prepare a Werner-like state (14) with fidelity $F = 6/19$ for three parties, Alice, Bob and Charlie is the following. Suppose a preparer, say Trent, prepares an ensemble of n GHZ states. Each GHZ state consists of a trio of qubits. For each trio, Trent gives one qubit to Alice (A). What happens to the two remaining qubits of the trio? Well, with a probability one half, he gives the two remaining qubits to Bob (B) and Charlie (C) and a maximally mixed state to David (D) and Eva (E). And, with a probability one half, he gives the two remaining qubits to David (D) and Eva (E) instead and gives a maximally mixed state to Bob (B) and Charlie (C). Now suppose Alice, Bob and Charlie are interested in GHZ distillation, but the three parties do not know which trios are shared between Alice, Bob and Charlie, and which between Alice, David and Eva. Then, the state of the trio can be described by a density matrix of a tripartite Werner-like state (14) with $\alpha = 1/2$, i.e., $\rho_W = 1/2|\Phi^+\rangle\langle\Phi^+| + \frac{1}{16}I$ and thus has a fidelity $F = 9/16$.

We now argue that such a Werner-like state with $F = 9/16$ cannot be distilled without Alice receiving communications from Bob and Charlie. This is done by a symmetry argument. Suppose there exists a conference key agreement protocol that does not require Alice to receive any communications from

Bob and Charlie. Then, in the end, Alice, Bob and Charlie will have a secret key, k , safe from eavesdroppers. However, since the Bob/Charlie pair is symmetric under interchange with the David/Eva pair, we can argue that Alice, David, Eva must share the same secret key, k . But, this contradicts the requirement that the key is secure against any eavesdropper (because, clearly, Bob and Charlie know the key, k).

In contrast, in Subsection VI-A, we showed that three-party secure conference key agreement can be achieved for a Werner-like state with fidelity $F \geq 0.3976$, if two-way classical communications are used. Therefore, any Werner-like states with a fidelity $0.3976 \leq F \leq 9/16$ can be used for secure conference key agreement with two-way protocols, but not with any one-way protocols. This is a demonstration of the power of two-way classical communications in multi-party quantum cryptography.

B. Comparison with violation of Bell inequalities

It is claimed in Refs. [31], [32] that a violation of Bell inequalities is a criterion for security of secret sharing schemes [10] with the assumption that Eve would be able to make only individual attacks. The security of protocols given in Refs. [31], [32] makes use of a one-way protocol to extract a secret key. We remark that such a claim does not apply to the present context where we allow the parties to perform two-way communications. Violation of Bell inequalities for N particles Werner-like state is shown in Ref. [33] to be $\alpha > 1/\sqrt{2^{(N-1)}}$. For a tripartite system, this gives $\alpha > 1/2$ and thus $F > 9/16 \doteq 0.5625$. This is clearly a higher requirement for the initial fidelity of a Werner-like state than that for our two-way prepare and measure secret sharing scheme which only requires $F \geq 0.5372$. Thus our two-way protocols are secure even when Bell inequalities are not violated. This is another demonstration of the power of two-way classical communications in multi-party quantum cryptography.

IX. CONCLUDING REMARKS

In this paper, we study three multi-party quantum cryptographic protocols: (a) conference key agreement, (b) quantum sharing of classical secrets and (c) third-man cryptography. We start with a protocol for GHZ distillation and convert it to a “prepare-and-measure” protocol for quantum cryptography. The main requirement for a protocol to be convertible to a prepare-and-measure protocol is that it cannot include any phase error detection steps. This is because phase error patterns are generally unavailable to the parties.

We remark that our three-party quantum cryptographic protocol can be implemented by with the generation of a single entangled pair of photons at a time. This is a major improvement over previous experimental demonstrations [14].

Our protocol can be readily generalized to the case of $N > 3$ parties and be implemented by using only $(N - 1)$ -partite entangled states. In the course of our investigation, we construct more efficient hashing protocols for GHZ distillation. Our protocol applies to not only a GHZ state, but also a general CSS-state. Moreover, we show that CSS-states are mathematically equivalent to two-colorable graph states, thus

putting the prior work on distillation of two-colorable graph states [8], [9] in a more systematic setting.

We note that our protocols, which involves two-way classical communications, are provably better than any protocol involving only one-way classical communication. Furthermore, our protocols work even when the initial state fails to violate the standard Bell inequalities for GHZ-states.

However, we remark that our protocols are not proven to be optimal. In future, it will be interesting to search for protocols that can distill even noisier initial states. Except for the case of hashing protocols, in this paper we have not looked into the issue of yield closely. This can be an important subject for future investigations.

It will also be interesting to a) explore further the connection of our work with aforementioned subjects (e.g. non-two-colorable graph state distillation) and b) generalize our results to quantum sharing of classical secrets for more general access structures. In the long term, it is our hope that such investigations will shed some light on the fundamental questions of the classification of multi-party entanglement and multi-party entanglement distillation. In conclusion, the power and limitations of multi-party quantum cryptography deserve future investigations.

ACKNOWLEDGMENTS

We thank helpful discussions with various colleagues including Panos Aliferis, Hans Briegel, Daniel Gottesman, Peter Knight, Manny Knill, Masato Koashi, Debbie Leung, Norbert Lütkenhaus, John Preskill and Yaoyun Shi. We are indebted to Eric Rains for showing that CSS states are two-colorable graph states. (Part B of Claim 2.) We also thank Xiongfeng Ma for some help in computer programming. This work was supported in part by Canadian NSERC, Canada Research Chairs Program, Connaught Fund, Canadian Foundation for Innovation, Ontario Innovation Trust, Premier's Research Excellence Award, Canadian Institute for Photonics Innovations, University of Toronto start-up grant, and the National Science Foundation under grant EIA-0086038 through the Institute for Quantum Information at the California Institute of Technology.

REFERENCES

- [1] P. Horodecki, R. Horodecki, "Distillation and bound entanglement", *Quantum Inf. & Comp.*, vol. 1, p. 45 (2001).
- [2] C. H. Bennett *et al.*, *Phys. Rev. Lett.*, vol. 76, p. 722 (1996).
- [3] C.H. Bennett, D.P. DiVincenzo, J.A. Smolin, and W.K. Wootters, "Mixed-state entanglement and quantum error correction", *Phys. Rev.*, vol. A54, p. 3824 (1996). Also [Online]. Available: <http://arxiv.org/abs/quant-ph/9604024>.
- [4] M. Murao, M.B. Plenio, S. Popescu, V. Vedral, and P.L. Knight, "Multiparticle entanglement purification protocols", *Phys. Rev.*, vol. A57, p. R4075 (1998). Also [Online]. Available: <http://arxiv.org/abs/quant-ph/9712045>.
- [5] W. Dür, J.I. Cirac, and R. Tarrach, "Separability and distillability of multiparticle quantum systems", *Phys. Rev. Lett.*, vol. 83, p. 3562 (1999). Also [Online]. Available: <http://arxiv.org/abs/quant-ph/9903018>.
- [6] W. Dür, and J.I. Cirac, "Classification of multiqubit mixed states: separability and distillability properties", *Phys. Rev.*, vol. A61, p. 042314 (2000). Also [Online]. Available: <http://arxiv.org/abs/quant-ph/9911044>.
- [7] E.N. Maneva, and J.A. Smolin, "Improved two-party and multi-party purification protocols", in: *AMS Contemporary Mathematics Series*, vol. 305, S.J. Lomonaco, and H.E. Brandt (Eds.), AMS, (2002), pp. 203–212. Also [Online]. Available: <http://arxiv.org/abs/quant-ph/0003099>.
- [8] W. Dür, H. Aschauer, and H.-J. Briegel, "Multiparticle entanglement purification for graph states", *Phys. Rev. Lett.*, vol. 91, p. 107903 (2003). Also [Online]. Available: <http://arxiv.org/abs/quant-ph/0303087>.
- [9] M. Hein, J. Eisert, H. J. Briegel, "Multi-party entanglement in graph states". Also [Online]. Available: <http://arxiv.org/abs/quant-ph/0307130>.
- [10] M. Hillery, V. Bužek, and A. Berthiaume, "Quantum secret sharing", *Phys. Rev.*, vol. A59, p. 1829 (1999). Also [Online]. Available: <http://arxiv.org/abs/quant-ph/9806063>.
- [11] D. Gottesman, and H.-K. Lo, "Proof of security of quantum key distribution with two-way classical communications", *IEEE Trans. Inf. Theor.*, vol. 49, p. 457 (2003). Also [Online]. Available: <http://arxiv.org/abs/quant-ph/0105121>.
- [12] P.W. Shor and J. Preskill, "Simple proof of security of the BB84 quantum key distribution protocol", *Phys. Rev. Lett.*, vol. 85, p. 441 (2000). Also [Online]. Available: <http://arxiv.org/abs/quant-ph/0003004>.
- [13] D. Mayers, "Unconditional security in quantum cryptography", *Journal of ACM*, vol. 48, Issue 3, p. 351-406. Also [Online]. Available: <http://xxx.lanl.gov/abs/quant-ph/9802025>. A preliminary version is D. Mayers, "Quantum key distribution and string oblivious transfer in noisy channels", *Advances in Cryptology-Proceedings of Crypto 96* (Springer-Verlag, New York, 1996), p. 343.
- [14] Y.-A. Chen, A.-N. Zhang, Z. Zhao, X.-Q. Zhou, C.-Y. Lu, C.-Z. Peng, T. Yang, J.-W. Pan, "Experimental Quantum Secret Sharing and Third-Man Quantum Cryptography," [Online]. Available: <http://arxiv.org/abs/quant-ph/0502131>.
- [15] Eric Rains, private communications.
- [16] H.-K. Lo, and H. F. Chau, "Unconditional security of quantum key distribution over arbitrarily long distances", *Science*, vol. 283, p. 2050 (1999). Also [Online]. Available: <http://arxiv.org/abs/quant-ph/9803006>.
- [17] See, for instance, Section 22.7, of B. Schneier, *Applied Cryptography*, 2nd Edition, Wiley, New York, 1996.
- [18] H.-K. Lo, "Proof of unconditional security of six-state quantum key distribution scheme", *Quantum Inf. & Comp.*, vol. 1, p. 81 (2001). Also [Online]. Available: <http://arxiv.org/abs/quant-ph/0102138>.
- [19] J. Preskill and D. Gottesman, "Secure Quantum Key Distribution Using Squeezed States", *Phys. Rev. A*, vol. 63, p.022309 (2001). Also [Online]. Available: <http://arxiv.org/abs/quant-ph/0008046>
- [20] H.-K. Lo, H. F. Chau, M. Ardehali, "Efficient Quantum Key Distribution Scheme and Proof of its Security", *J. of Cryptology*, vol. 18, Number 2, p. 133-165 (2005). Also [Online]. Available: <http://arxiv.org/abs/quant-ph/0011056>.
- [21] T. Cover & J. Thomas, *Elements of Information Theory*, Wiley, New York, 1991.
- [22] R.F. Werner, "Quantum states with Einstein-Podolsky-Rosen correlations admitting a hidden-variable model", *Phys. Rev.*, vol. A40, p. 4277 (1989).
- [23] A. Peres, "Separability criterion for density matrices", *Phys. Rev. Lett.*, vol. 77, p. 1413 (1996). Also [Online]. Available: <http://arxiv.org/abs/quant-ph/9604005>.
- [24] M. Horodecki, P. Horodecki, and R. Horodecki, "Separability of mixed states: necessary and sufficient conditions", *Phys. Lett.* vol. A223, p. 1 (1996). Also [Online]. Available: <http://arxiv.org/abs/quant-ph/9605038>.
- [25] A.R. Calderbank and P.W. Shor, "Good quantum error-correcting codes exist", *Phys. Rev.*, vol. A54, p. 1098 (1996). Also [Online]. Available: <http://arxiv.org/abs/quant-ph/9512032>.
- [26] A.M. Steane, "Error correcting codes in quantum theory", *Phys. Rev. Lett.*, vol. 77, p. 793 (1996).
- [27] A. Miyake and H. J. Briegel, "Distillation of multipartite entanglement by dual stabilizer measurements", [On-line] Available: <http://arxiv.org/abs/quant-ph/0506092>.
- [28] R. Cleve, D. Gottesman, and H.-K. Lo, "How to share a quantum secret?", *Phys. Rev. Lett.*, vol. 83, p. 648 (2003). Also [Online]. Available: <http://arxiv.org/abs/quant-ph/0102138>.
- [29] D. Gottesman, "On the theory of quantum secret sharing", *Phys. Rev.*, vol. A61, p. 042311 (2000). Also [Online]. Available: <http://arxiv.org/abs/quant-ph/9901025>.
- [30] A.D. Smith, "Quantum secret sharing for general access structures". Also [Online]. Available: <http://arxiv.org/abs/quant-ph/0001087>.
- [31] V. Scarani and N. Gisin, "Quantum communication between N partners and Bells inequalities", *Phys. Rev. Lett.*, vol. 87, p. 117901 (2001). Also [Online]. Available: <http://arxiv.org/abs/quant-ph/0101110>.
- [32] V. Scarani and N. Gisin, "Quantum key distribution between N partners: optimal eavesdropping and Bells inequalities", *Phys. Rev.*, vol. A65, p. 012311 (2001). Also [Online]. Available: <http://arxiv.org/abs/quant-ph/010016>.

- [33] M. Żukowski and Č. Brukner, “Bell theorem for general N -qubits states”, *Phys. Rev. Lett.*, vol. 88, p. 210401 (2002). Also [Online]. Available: <http://arxiv.org/abs/quant-ph/0102039>.