

Observation of β decay of ^{115}In to the first excited level of ^{115}Sn

C. M. Cattadori ^{a,b}, M. De Deo ^a, M. Laubenstein ^a,
L. Pandola ^{a,c,*}, V. I. Tretyak ^d

^a*INFN, Laboratori Nazionali del Gran Sasso, S.S. 17 bis km 18+910, I-67010 L'Aquila, Italy*

^b*INFN Milano, Via Celoria 16, I-20133 Milano, Italy*

^c*Università dell'Aquila, Dipartimento di Fisica, Via Vetoio 1, I-67010 L'Aquila, Italy*

^d*Institute for Nuclear Research, MSP 03680, Kiev, Ukraine*

Abstract

In the context of the LENS R&D solar neutrino project, the γ spectrum of a sample of metallic indium was measured using a single experimental setup of 4 HP-Ge detectors located underground at the Gran Sasso National Laboratories (LNGS), Italy. A γ line at the energy (497.48 ± 0.21) keV was found that is not present in the background spectrum and that can be identified as a γ quantum following the β decay of ^{115}In to the first excited state of ^{115}Sn ($\frac{9}{2}^+ \rightarrow \frac{3}{2}^+$). This decay channel of ^{115}In , which is reported here for the first time, has an extremely low Q_β -value, $Q_\beta = (2 \pm 4)$ keV, and has a much lower probability than the well-known ground state-ground state transition, being the branching ratio $b = (1.18 \pm 0.31) \cdot 10^{-6}$. This could be the β decay with the lowest known Q_β -value. The limit on charge non-conserving β decay of ^{115}In is set at 90% C.L. as $\tau_{CNC} > 4.1 \cdot 10^{20}$ y.

Key words: Indium, β decay, γ spectroscopy

PACS: 23.20.Lv, 23.40.-s, 27.60.+j

* INFN, Laboratori Nazionali del Gran Sasso, S.S. 17 bis km 18+910, I-67010 L'Aquila, Italy. Telephone number: +39 0862 437532, Fax number: +39 0862 437570
Email address: pandola@lngs.infn.it (L. Pandola).

1 Introduction

^{115}In has been envisaged in the LENS project (Low Energy Neutrino Spectroscopy) as a possible target for the real-time measurement of low energy solar neutrinos. The detection principle is based on the inverse electron capture (EC) reaction $^{115}\text{In}(\nu_e, e^-)^{115}\text{Sn}^*$ on ^{115}In , which has a threshold energy of 114 keV and populates the second excited state of ^{115}Sn at 613 keV (see Fig. 5 later). This state is metastable, with a life time $\tau = 4.76 \mu\text{s}$, and its subsequent two-step decay to the ground state provides an highly specific ν signature [1]. Namely, the prompt electron emitted in the inverse-EC reaction (e_1) is followed, with a typical delay of $\tau=4.76 \mu\text{s}$, by a localized deposition of 116 keV (e/γ)₂, in spatial coincidence, and by a γ -ray (γ_3) of 497 keV (see Fig. 5). Though ^{115}In has several favorable features as a target for low energy solar neutrinos (high isotopic abundance, low threshold, strong ν -tag), the detection technique is extremely challenging because ^{115}In is unstable and can β -decay directly to the ^{115}Sn ground state. The specific activity of natural indium is 0.25 Bq/g and thus indium itself is the major irremovable source of background. The LENS R&D project has demonstrated that the 10^6 background suppression factor needed for the pp solar neutrino measurement can be achieved, however at the cost of a very high segmentation ($\sim 10^5$ cells) and of an one-order-of-magnitude increase of the overall detector mass [1].

The most serious background that has to be faced is related to the coincidence of two spatially-close indium decays. The coincidence of two ^{115}In decays can mimic the ν -tag if the second β has energy close to the end point and emits a hard bremsstrahlung γ . The importance of this source of background depends on the granularity of the detector (because of the requirement of spatial coincidence), on the energy resolution and on the indium bremsstrahlung spectrum. In order to have a better comprehension and characterization of the bremsstrahlung, a measurement of the γ spectrum of an indium sample was performed with HP-Ge detectors in the Low-Level Background Facility underground in the Gran Sasso National Laboratories, Italy. During the analysis of the data we found evidence for a previously unknown decay of ^{115}In to the first excited level of ^{115}Sn , at the energy 497.4 keV.

In Section 2 we describe the indium sample and the experimental details of the measurement. In Section 3 we present the spectrum and the evidence for the γ line at 497 keV. In Section 4 we discuss the interpretation of this line in terms of decay of ^{115}In to the first excited state of ^{115}Sn and the consequent limit set on the ^{115}In charge non-conserving decay. Finally, in Section 5 we summarize our results and briefly describe some possible future perspectives.

Table 1
Germanium detectors parameters

	Detectors			
	ge178	ge179	ge180	ge188
Volume (cm ³)	225.2	225.0	225.0	220.7
Endcap and holder material	Electrolytical Copper			
Energy resolution (FWHM) at 1332 keV	2.1	2.0	2.0	2.0

2 The setup

2.1 The sample and the detector

The sample used for the measurement consists of an ingot of metallic ^{nat}In of mass (928.7±0.1) g. It has the shape of a cylindrical shell, with the approximate dimensions of 2.0 cm (internal diameter), 5.5 cm (external diameter) and 6.5 cm (height). The high-purity indium (6N5 grade) used for the production of the sample has been provided by the Indium Corporation of America in May 2002.

The γ spectrum of the indium source was measured using a set of 4 HP-Ge detectors installed underground at LNGS. The detectors are very similar coaxial germanium crystals mounted altogether in one cryostat made by Canberra; their main parameters are displayed in Table 1. They are arranged as shown in Fig. 1 and surround the indium sample, which is placed in the central well. The experimental setup is enclosed in a lead/copper passive shielding and has a nitrogen ventilation system against radon.

One measurement of the indium ingot (2762.3 h of counting time for each detector) and one of the background (1601.0 h) were carried out, both with the complete shielding around the detectors.

2.2 Detector performances

The detectors show a very good energy resolution and linearity. The efficiency of the configuration (detectors and ingot) has been evaluated using the GEANT4-based code JAZZY, developed by O. Cremonesi¹. The computed full energy efficiency, i.e. the probability that a γ ray produced in a random position of the indium ingot deposits its full energy in one of the four Ge detectors, is displayed in Fig. 2 as a function of energy. The Monte Carlo code has been checked, with the procedure described in Ref. [2], using a previous

¹ INFN Milano and Milano Bicocca University.

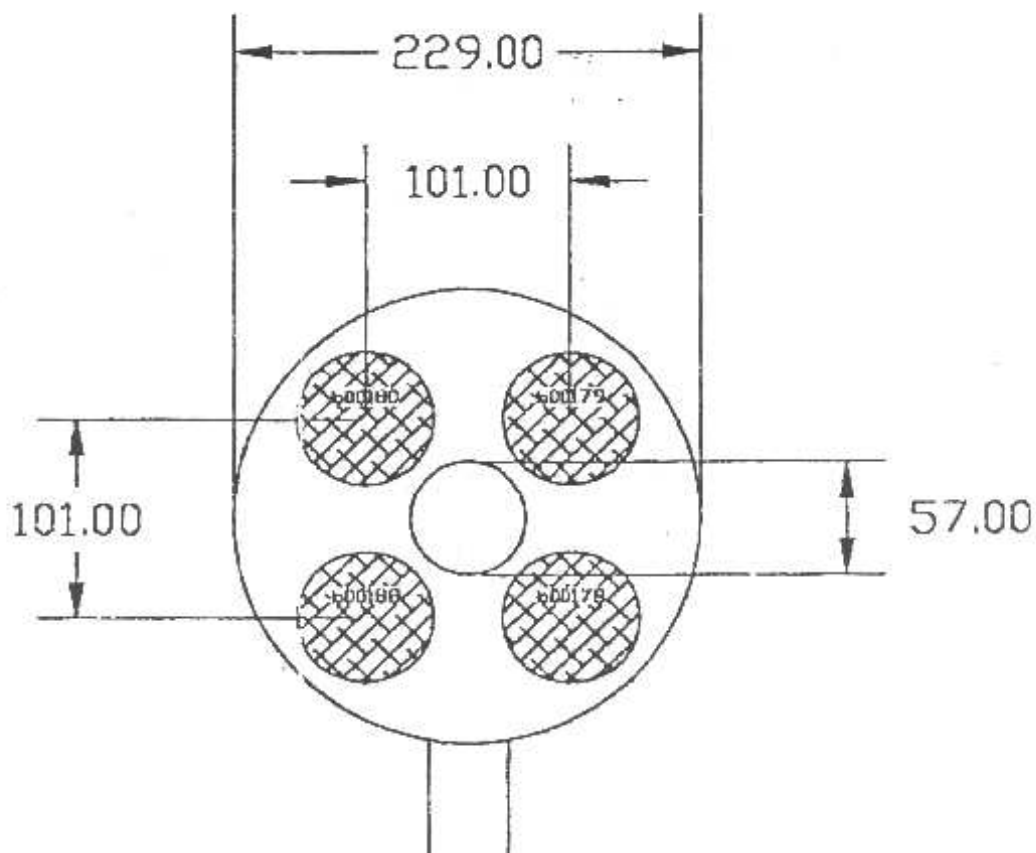

Fig. 1. Top view of the experimental setup. Dimensions are in mm.

measurement performed in the same setup with a ^{60}Co γ source (1173 keV and 1332 keV). Taking into account the 2505 keV sum peak in the experimental spectrum and neglecting the angular correlations of the two photons, the measured absolute efficiencies in this configuration agree with the computed ones at 12% and are consistent within their statistical uncertainties. On the basis of our previous experience with similar simulations of analogous experimental setups we estimate the systematic uncertainty on the Monte Carlo efficiencies to be 10%. In any case, the knowledge of the absolute efficiency at the few % level is not needed for the present analysis, as it does not represent the main contribution to the uncertainty on the measured $^{115}\text{In} \rightarrow ^{115}\text{Sn}^*$ decay rate (see Sect. 4). For this reason, we can conclude that our knowledge of the detector and of the absolute efficiency is satisfactory for our purposes.

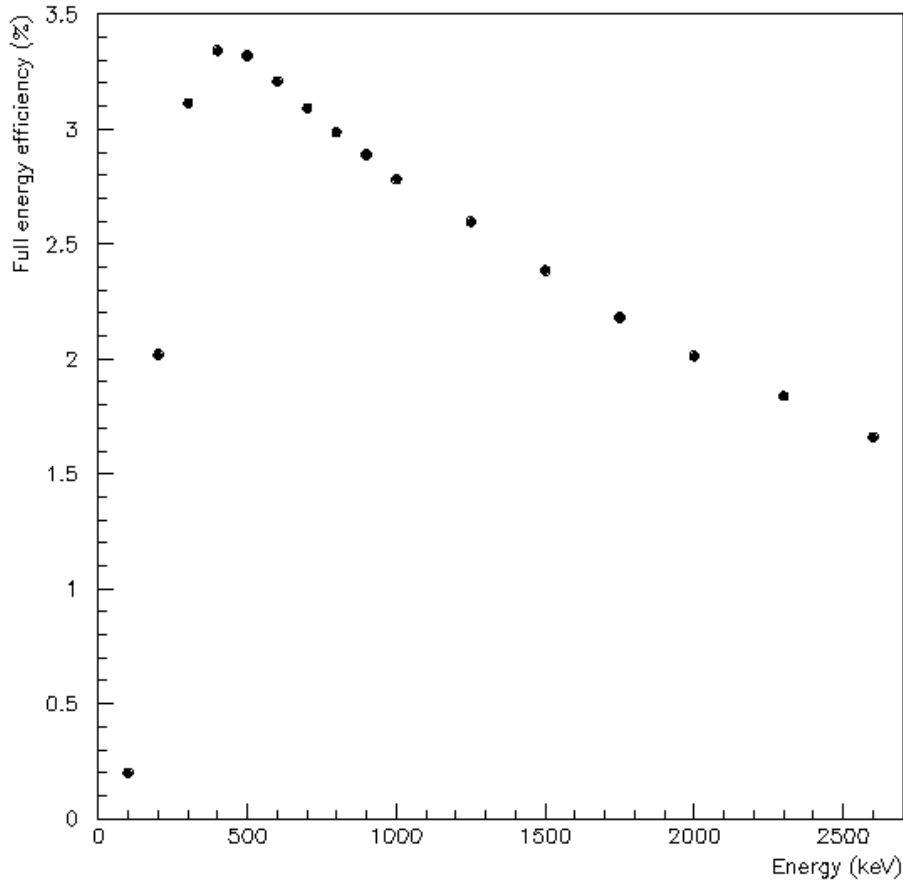

Fig. 2. Simulated full energy efficiency of the 4-detector setup

3 Analysis of the measured spectra

3.1 Comparison of indium and background spectra

The spectra obtained by the four detectors for the indium sample and for the background have been added (see Fig. 3) and analyzed using both an automatic program and visual inspection. In the indium measurement, besides the continuous component (see Fig. 3a) due to the bremsstrahlung of the electrons from the β decay of ^{115}In (end point: 499 keV), 42 γ lines with energy above 200 keV could be identified: they are listed, together with their interpretation, in Table 2. The same γ lines, except the one at (497.48 ± 0.21) keV (which represents the main point of this paper and will be discussed in detail in the following sections), are also found in the background spectrum, though some of them (e.g. 795, 1588 and 2447 keV) have a poor statistical significance because of the shorter measurement time. As shown in Table 2, the observed γ lines come from the natural radionuclides and radioactive series (^{40}K , ^{238}U , ^{235}U , ^{232}Th) and from cosmogenic or antropogenic nuclides (^{60}Co , ^{137}Cs , ^{207}Bi ,

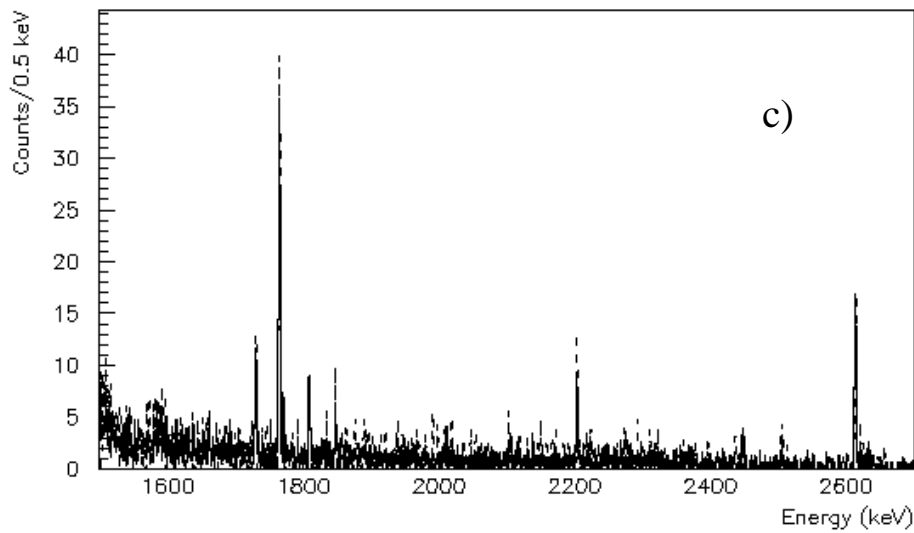
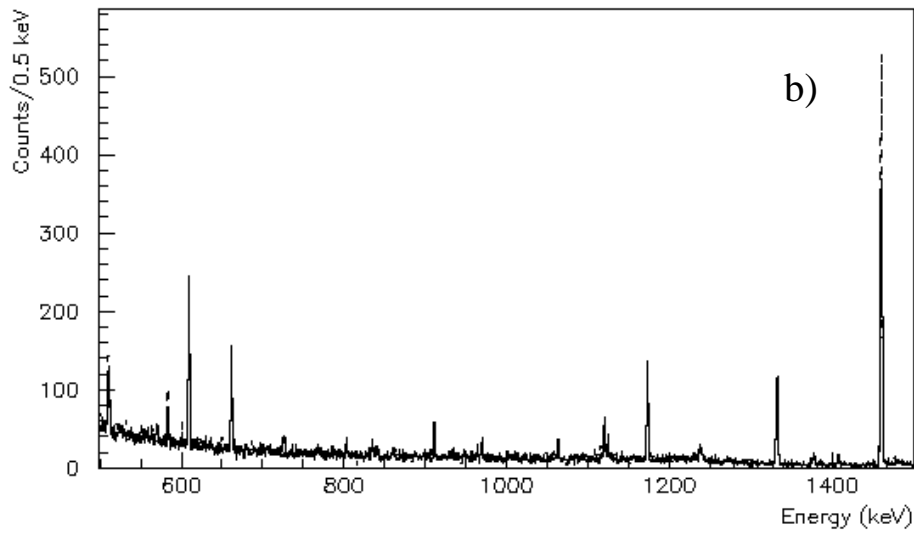
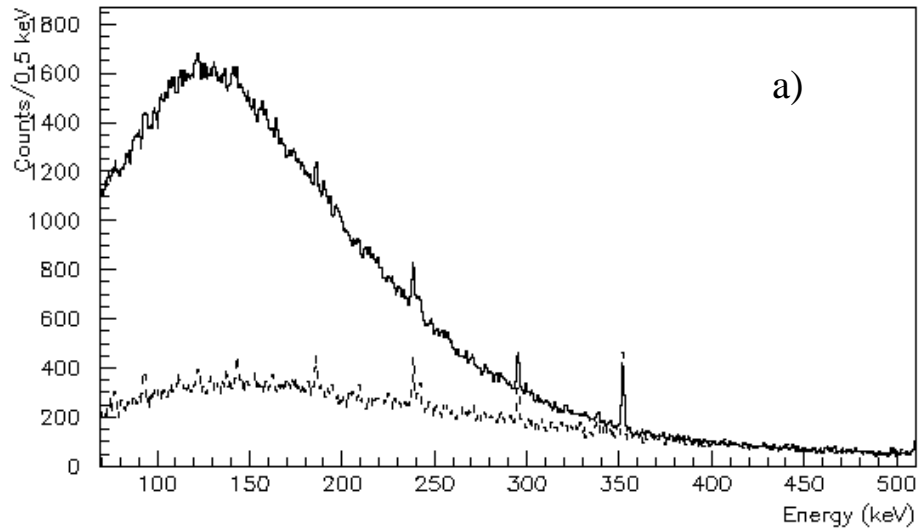

Fig. 3. Experimental γ spectrum in the regions 70–510 keV (a), 500–1500 keV (b) and 1500–2700 keV (c) for the indium sample (solid line) superimposed with the background spectrum (dashed line) normalized to the same counting time.

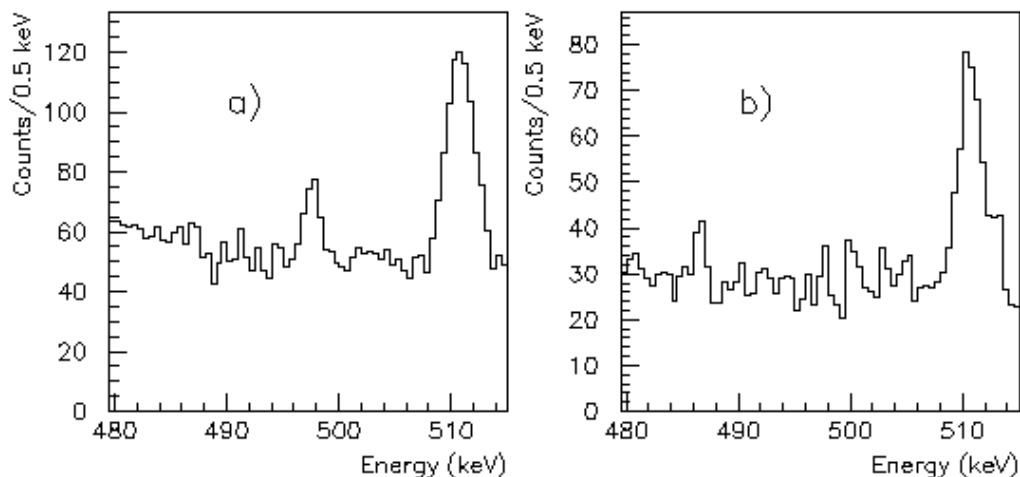

Fig. 4. Spectrum in the region 480–515 keV (a) for the indium sample and (b) for the background.

^{26}Al) that are usually present as contaminations in normal copper and lead. The same Table shows the counting rates of the γ lines for the indium sample and the background, as well as their difference (statistical errors only). For each line (except the one at 497 keV) the difference turns out to be statistically consistent with zero. Hence there is no statistical evidence of radioactive contamination of the indium sample, since the data are consistent with contaminations of the experimental setup only (germanium crystals and passive lead/copper shielding).

The efficiencies quoted in Table 2 (full energy efficiencies) have been calculated in the hypothesis that the γ rays are generated inside the indium sample so they include the effect of self-absorption in the ingot itself. The fact that in some cases the indium-background difference rate is negative (though statistically consistent with zero) is explained because indium is an effective γ ray absorber (the atomic number Z is 49) and can hence act as an additional shielding for the Ge detectors with respect to the background measurement, where the well is filled with a plexiglas plug.

3.2 The 497 keV line

As anticipated in Sect. 3.1, the only γ line of the indium spectrum which is not present in the background measurement and cannot be ascribed to the usual radioactive contaminants is located at the energy of (497.48 ± 0.21) keV. The interesting region of the spectrum is shown in Fig. 4. From the fit of the indium spectrum in the energy region (487–508) keV with a Gaussian peak and linear background assumption, we get a net area of (90 ± 22) counts, inconsistent with zero at more than 4σ . This corresponds to a counting rate of

(0.78 ± 0.19) counts/day. Variations of the energy interval for the fit result in changes of the area inside the quoted uncertainty. With the same procedure applied to the background spectrum, no Gaussian peak could be found and the resulting area is (0 ± 14) counts; the corresponding upper limit derived with the Feldman-Cousins method [3] is 23.0 counts (90% CL) or 0.34 counts/day (90% CL).

It can hence be concluded that the peak under examination is statistically significant and related with the indium sample, being absent in the background measurement.

4 Interpretation

4.1 Decay of ^{115}In to the first excited state of ^{115}Sn

The peak with the energy (497.48 ± 0.21) keV found in the indium measurement and absent in the background one can be explained with the β decay of ^{115}In to the first excited level of ^{115}Sn , whose excitation energy is 497.4 keV. Such a process has never been observed previously and the β decay of ^{115}In was considered up-to-date as going exclusively to the ground state of ^{115}Sn [4,5,6]. Because of the large change in the nuclear angular momentum ($\frac{9}{2}^+ \rightarrow \frac{1}{2}^+$), the ground state to ground state β decay of ^{115}In is a 4th forbidden transition and has one of the largest known $\log ft$ values ($\log ft = 22.5$). The measured half life of ^{115}In is $t_{1/2} = 4.41 \cdot 10^{14}$ y [4,5,6,7].

According to the most recent table of atomic masses [8], the mass difference between ^{115}In and ^{115}Sn is (499 ± 4) keV. The decay $^{115}\text{In} \rightarrow ^{115}\text{Sn}^*$ to the first excited level of ^{115}Sn is hence kinematically allowed, though with an extremely small Q_β value, $Q_\beta = (1.6 \pm 4.0)$ keV.

Using the area of the 497 keV peak observed in the indium spectrum, the decay rate for the transition to the first excited level of ^{115}Sn can be evaluated through the relation

$$\Gamma(^{115}\text{In} \rightarrow ^{115}\text{Sn}^*) = \frac{S(1 + \alpha)}{N \varepsilon t_M}, \quad (1)$$

where ε is the efficiency to detect the full energy γ with the 4 Ge detectors, N is the number of ^{115}In nuclei in the sample, t_M is the measurement time, S is the area of the peak and α is the coefficient of conversion of γ quanta to electrons for the given nuclear transition.

The full peak efficiency at 497 keV is $\varepsilon = (3.32 \pm 0.33)\%$ and it was evaluated using the Monte Carlo simulation described in Sect. 2.2. Taking into account the total mass of the indium sample (928.7 g), the atomic weight of indium

(114.8 g·mol⁻¹) [9] and the isotopic abundance of ¹¹⁵In (95.7%) [10], the number of ¹¹⁵In nuclei in our sample results to be $N=4.66\cdot 10^{24}$. The area of the peak is (90±22) counts (see Sect. 3.2) and the electron conversion coefficient for the transition is $\alpha=8.1\cdot 10^{-3}$ [5]. With these values and $t_M=2762.3$ h, the decay rate for the ¹¹⁵In β decay to the first excited level of ¹¹⁵Sn is estimated to be

$$\Gamma(^{115}\text{In} \rightarrow ^{115}\text{Sn}^*) = (1.86 \pm 0.49) \cdot 10^{-21} \text{ y}^{-1}, \quad (2)$$

that corresponds to a partial half life of

$$t_{1/2}(^{115}\text{In} \rightarrow ^{115}\text{Sn}^*) = \frac{\ln 2}{\Gamma} = (3.73 \pm 0.98) \cdot 10^{20} \text{ y}. \quad (3)$$

The probability of this process is thus near one million times lower than for the transition to the ground state of ¹¹⁵Sn (see Fig. 5); the experimental branching ratio is

$$b = (1.18 \pm 0.31) \cdot 10^{-6}. \quad (4)$$

The uncertainty on the decay rate and on the branching ratio mainly comes from the statistical error on the net area of the 497 keV peak. Nuclear spin and parity are changed in the observed transition from the initial $\frac{9}{2}^+$ of the ¹¹⁵In ground state to $\frac{3}{2}^+$ of ¹¹⁵Sn*; this is therefore a 2nd forbidden unique β decay. The recommended value of $\log ft$ for such a decay is equal to (11.7±0.9) [11]. With the measured value of the half life of $(3.73 \pm 0.98) \cdot 10^{20}$ y, the “experimental” $\log f$ value can be calculated as $\log f = (-16.37 \pm 0.91)$. On the other hand, the $\log f$ value can be estimated using the formalism described in [12]:

$$f = f_0 s_2, \quad (5)$$

where f_0 is the value for the allowed transition and s_2 is the correction for the 2nd forbidden unique decay. The f_0 factor can be written as

$$f_0 = \phi_0 s_0, \quad (6)$$

where ϕ_0 is the phase space integral

$$\phi_0 = \int_1^{W_0} W \sqrt{W^2 - 1} (W_0 - W)^2 dW, \quad (7)$$

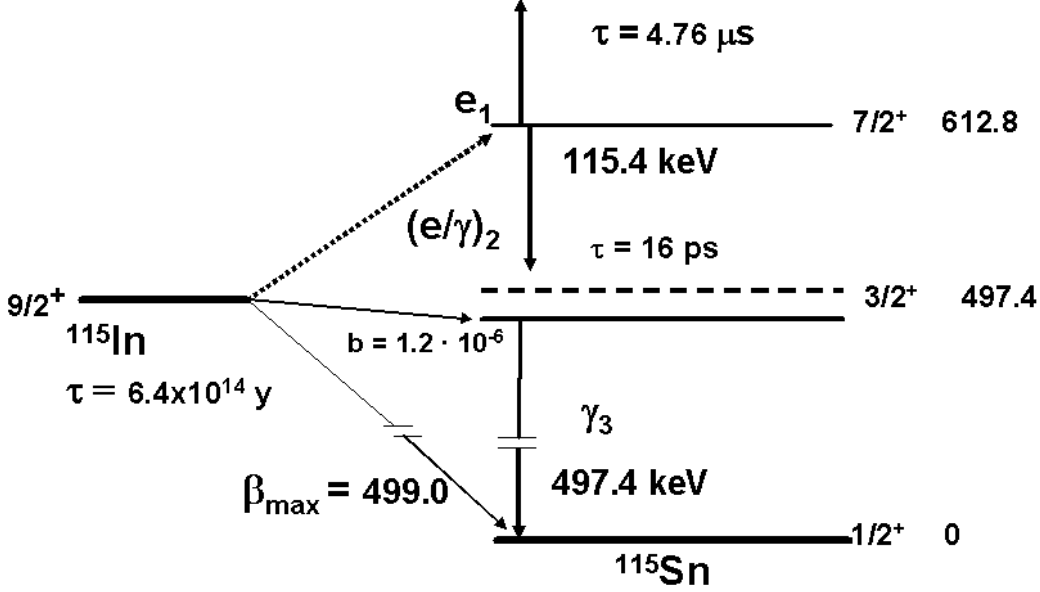

Fig. 5. New level scheme for ^{115}In and ^{115}Sn as a result after this work. The $\frac{3}{2}^+$ level of ^{115}Sn is shown in its old (dashed line) and new (solid line) position, namely above and below the ^{115}In ground state. The nuclear transitions relevant for the LENS neutrino tagging are also shown.

W_0 is the energy release in the β -decay in units of the electron mass and s_0 is the correction for a non-zero Z value of the daughter nucleus. The phase space integral can be analytically calculated as

$$\phi_0 = \sqrt{W_0^2 - 1} \frac{2W_0^4 - 9W_0^2 - 8}{60} + \frac{W_0}{4} \ln(W_0 + \sqrt{W_0^2 - 1}), \quad (8)$$

while the s_0 values are tabulated in [12]. The correction s_2 can be estimated following Ref. [13] as:

$$s_2 = \frac{1}{1080} \left[\frac{3}{7} (W_0^2 - 1)^2 - \frac{26}{105} (W_0^2 - 1)(W_0 - 1) - \frac{2}{105} (W_0 - 1)^2 \right]. \quad (9)$$

In this way the $\log f$ value for $Q_\beta = 1.6$ keV is equal to -15.78 , which is in agreement with the experimental value of $\log f = (-16.37 \pm 0.91)$.

The $\log f$ value can also be evaluated with the help of the LOGFT tool at the National Nuclear Data Center, USA [14] which is based on procedures described in [15]. The value of $\log f$ for $Q_\beta = 1.6$ keV calculated with the LOGFT code is however very different from the previous estimation: $\log f = -10.8$; this means that with such a Q_β the beta decay should go near 6 orders of magnitude faster. One can solve the inverse problem and use the LOGFT code to adjust the Q_β value corresponding to the measured $\log f = (-16.37 \pm 0.91)$.

Such a procedure gives an extremely low value of $Q_\beta = (23_{-12}^{+23})$ eV.

While both these calculations can be considered as very tentative and not being intended to be used for such low energies, the last estimation gives a hint that the Q_β value in the beta decay $^{115}\text{In} \rightarrow ^{115}\text{Sn}^*$ can be very close to zero². Such a unique situation could be used to establish a limit on the antineutrino mass, in addition to the experiments with ^3H and ^{187}Re , where up-to-date limits are in the range of $\simeq 2$ eV [18] and $\simeq 15$ eV [19], respectively. To do this in a competitive way both the ^{115}In Q_β -value and the energy of the ^{115}Sn 497.4 keV level should be measured with an accuracy of ~ 1 eV or better. The uncertainty in the energy of the 497.4 keV level is equal now to 22 eV [5] and it could be further reduced doing an accurate investigation of the ^{115}Sb decay³. The atomic mass difference $^{115}\text{In} - ^{115}\text{Sn}$ can possibly also be measured with an accuracy of ~ 1 eV. For example, the mass difference of $^{76}\text{Ge} - ^{76}\text{Se}$ was determined with 50 eV uncertainty in Ref. [20], where it was stated that the Penning traps technique is able to deliver even more accurate results. Both such measurements require strong experimental efforts but the physical result could be very interesting and important.

4.2 Possible imitation of the effect

In some nuclear processes γ rays with energies close to 497 keV are emitted. This could give an alternative explanation of the peak observed in the experimental spectrum. Luckily, additional γ rays are also emitted in such decays, allowing to tag those mimicking effects.

The ^{115}In nucleus has an isomeric state ^{115m}In with the energy $E_{iso} = 336.2$ keV and a half life of 4.5 h [4]. With the probability of 0.047% the ^{115m}In nucleus β -decays to the first excited level of ^{115}Sn , with the subsequent emission of a 497 keV γ ray [4,5,6]. However, in this case a γ ray with the energy $E_{iso} = 336.2$ keV is emitted with much higher probability (45.84% [4]) because of the electromagnetic transition from the isomeric ^{115m}In to the ground ^{115}In state. This huge peak at 336.2 keV, whose area should be $\sim 10^3$ times bigger than that of the observed 497.4 keV peak, is absent in the experimental spectrum; only a peak at 338.3 keV is observed, with the net area of (138 ± 50) counts, which corresponds to the decay of ^{228}Ac from the ^{232}Th natural chain (see Table 2). Therefore the decay of the isomeric state ^{115m}In is absolutely negligible and the 497 keV peak cannot be ascribed to it, not even in part. Similarly,

² Even the history of the Q_β evaluation for ^{115}In gives some indication for this: the Q_β value was slightly lower than energy of the first excited 497.4 keV ^{115}Sn state in accordance with older tables of atomic masses, $Q_\beta = (495 \pm 4)$ keV [16] and (496 ± 4) keV [17], while it is slightly higher in the last evaluation, (499 ± 4) keV [8].

³ It can be noted that energies of many γ lines of calibration sources are known with an accuracy of $(0.1 - 0.3)$ eV, also in the ~ 500 keV region of our interest [4].

given also the underground location of the experimental setup and the low flux of neutrons [21], we conclude that (n, γ) reactions cannot contribute to the peak under analysis.

Protons produced by fast neutron or cosmic ray muons can populate the second excited level of ^{115}Sn (Fig. 5) via the (p, n) reaction on ^{115}In ($E_{thr}=0.9$ MeV); the ^{115}Sn nucleus quickly returns to the ground state with the emission of two γ rays of energy 115.4 and 497.4 keV. The contribution originated by fast neutrons is practically zero (see f.i. [22]) because of the deep underground location and the lack of hydrogenous materials in the setup. On the other hand, since the muon flux in the laboratory is extremely low ($1 \mu/\text{m}^2\text{h}$ [23]), also the contribution of (p, n) reactions induced by cosmic rays (see also [24]) to the 497 keV peak is absolutely negligible ($< 10^{-3}$ counts).

Some decays from the natural ^{238}U and ^{232}Th chains can also give γ rays in the energy region of interest, though with very low intensity. They are in particular [4] ^{214}Bi ($E = 496.7$ keV, $I = 0.0069\%$), ^{228}Ac ($E = 497.5$ keV, $I = 0.0059\%$) and ^{234m}Pa ($E = 498.0$ keV, $I = 0.062\%$). However, the sum contribution of these decays to the 497 keV peak is less than 1 count and can be easily estimated using their stronger associated γ lines.⁴

We could not figure out other sources than can mimic the experimentally observed 497 keV peak.

4.3 Charge non-conserving β decay of ^{115}In

The present measurements give also the possibility to set a limit on the charge non-conserving (CNC) β decay of ^{115}In , a process in which the $(A, Z) \rightarrow (A, Z + 1)$ transformation is not accompanied by the emission of an electron [25,26]. It is supposed that instead of an e^- , a massless particle is emitted (for example a ν_e , a γ quantum, or a Majoron): $(A, Z) \rightarrow (A, Z + 1) + (\nu_e \text{ or } \gamma \text{ or } M) + \bar{\nu}_e$. Up-to-date, the CNC β decay was searched for with four nuclides only: ^{71}Ga , ^{73}Ge , ^{87}Rb and ^{113}Cd . Only lower limits on corresponding life times τ_{CNC} were established, in the range of $(10^{18} - 10^{26})$ y (we refer to the last work on this subject [27], where all previous attempts are reviewed). Measuring only the γ quanta from the deexcitation of the 497 keV level of ^{115}Sn , we cannot distinguish, in principle, which mechanism leads to the detected 497 keV peak: the CNC beta decay or the usual charge-conserving beta decay to the excited level of ^{115}Sn . If the whole area of the observed 497 keV peak is considered as belonging to the CNC beta decay (instead of the much less exotic usual β -decay of ^{115}In), and substituting in the formula for the life time

⁴ For instance, the area of the 338.3 keV line of ^{228}Ac , whose relative intensity is 11.27%, is only (138 ± 50) counts. Therefore, if the contamination were located in the indium ingot, the estimated contribution to the 497 keV peak, taking also into account the different full peak efficiency, would be $(7.3 \pm 2.6) \cdot 10^{-2}$ counts.

$\tau_{CNC} = \varepsilon \cdot N \cdot t_M / [S_{lim}(1 + \alpha)]$ the values of efficiency and other parameters described in section 4.1 together with $S_{lim} = 118$, the Feldman-Cousins 90% CL limit on the life time of this process is

$$\tau_{CNC} > 4.1 \cdot 10^{20} \text{ y.} \quad (10)$$

Though this value is relatively low, it is determined for the first time for ^{115}In , expanding the scarce information on the CNC processes.

5 Conclusions

From the measurement of the γ spectrum of a sample of metallic indium performed with HP-Ge detectors in the Low-Level Background Facility of the Gran Sasso Laboratory, we have found evidence for the previously unknown β decay of ^{115}In to the first excited state of ^{115}Sn at 497.4 keV ($\frac{9}{2}^+ \rightarrow \frac{3}{2}^+$). The Q_β -value for this channel is $Q_\beta = (2 \pm 4)$ keV; this could be lower than the Q_β -value of ^{163}Ho , $Q_\beta = 2.565$ keV [4,28], and hence be the lowest of all the known β decays. The branching ratio is found to be $b = (1.18 \pm 0.31) \cdot 10^{-6}$. We also set a limit on the charge non-conserving β decay of ^{115}In $\tau_{CNC} > 4.1 \cdot 10^{20}$ y (90% CL).

This measurement was carried out in the context of the LENS R&D project, with the aim of better characterize the ^{115}In bremsstrahlung spectrum, which is poorly known near its end-point. The discovered decay of ^{115}In on the first excited state of ^{115}Sn could in principle be dangerous for the LENS solar neutrino measurement, since it is an irremovable background source of 497 keV γ rays. The coincidence of ^{115}In decay on the ground state of ^{115}Sn and one ^{115}In decay on the first excited state can in fact mimic the ν -tag and the possible impact is currently under investigation.

In a future work we plan to study the possible atomic effects on the half life of the $^{115}\text{In} \rightarrow ^{115}\text{Sn}^*$ decay by measuring a new sample where indium is present in a different chemical form (e.g. InCl_3 solution instead of metallic indium).

We also point out that, given the extremely low Q_β value, the decay reported in this work could be used in a future experiment to directly measure the neutrino mass. In order to reduce the background due to the β decay of ^{115}In to the ground state of ^{115}Sn , such experiment would need a rejection power of 10^6 , that could be achieved tagging the 497 keV γ ray emitted in coincidence with the β particle. New In-based semiconductor detectors or fast bolometers could be used for the purpose.

6 Acknowledgments

The authors would like to thank O. Cremonesi, for providing his Monte Carlo code to estimate the efficiencies, E. Bellotti and Yu.G. Zdesenko, for their continuous support and useful advices, and A. di Vacri, who collaborated in the early stages of this work. We would also like to express our gratitude to D. Motta, for his valuable advices and feedback, and to the LNGS Mechanical Workshop, especially to E. Tatananni and B. Romualdi, for the melting of the indium ingot.

References

- [1] R.S. Raghavan, Phys. Rev. Lett. 37 (1976) 359; R.S. Raghavan, hep-ex/0106054; T. Bowles, Talk at VIII International Workshop on Topics in Astroparticle and Underground Physics (TAUP03), Seattle (2003), to appear in the Proceedings
- [2] C. Arpesella *et al.*, Nucl. Instr. Meth. A 372 (1996) 415
- [3] G.J. Feldman and R.D. Cousins, Phys. Rev. D 57 (1998) 3873
- [4] R.B. Firestone *et al.*, *Table of Isotopes*, John Wiley & Sons, New York, 8th Edition (1996) and CD update (1998)
- [5] J. Blachot, Nucl. Data Sheets 86 (1999) 151
- [6] G. Audi *et al.*, Nucl. Phys. A 729 (2003) 3
- [7] L. Pfeiffer *et al.*, Phys. Rev. C 19 (1979) 1035
- [8] G. Audi *et al.*, Nucl. Phys. A 729 (2003) 337
- [9] J.R. De Laeter *et al.*, Pure and Appl. Chem. 75 (2003) 683
- [10] *Handbook of Chem. Phys.*, 84th Edition, CRC Press (2003-2004)
- [11] E.Kh. Akhmedov, *Beta decay*, in: A.M. Prokhorov (Ed.), *Physical Encyclopedia*, Vol. 1 (Moscow, Sovetskaya Enciklopediya, 1988), p. 190, in Russian
- [12] B.S. Dzhelepov *et al.*, *Beta Processes. Functions for analysis of beta-spectra and electron capture* (Leningrad, Nauka, 1972), in Russian
- [13] J.P. Davidson, Jr., Phys. Rev. 82 (1951) 48
- [14] <http://www.nndc.bnl.gov/nndc/physco>
- [15] N.B. Gove, M.J. Martin, Nucl. Data Tables 10 (1971) 205
- [16] G. Audi, A.H. Wapstra, Nucl. Phys. A 565 (1993) 66
- [17] G. Audi, A.H. Wapstra, Nucl. Phys. A 595 (1995) 409

- [18] V.M. Lobashev, Nucl. Phys. A 719 (2003) 153
- [19] M. Sisti *et al.*, Nucl. Instrum. Meth. A 520 (2004) 125
- [20] G. Douysset *et al.*, Phys. Rev. Lett. 86 (2001) 4259
- [21] P. Belli *et al.*, Nuovo Cimento 101 A (1989) 959
- [22] M. Cribier *et al.*, Astrop. Phys. 4 (1995) 23
- [23] MACRO Collaboration, M. Ambrosio *et al.*, Phys. Rev. D 52 (1995) 3793
- [24] M. Cribier *et al.*, Astrop. Phys. 6 (1997) 129
- [25] G. Feinberg, M. Goldhaber, Proc. Nat. Acad. Sci. U.S.A. 45 (1959) 1301
- [26] L.B. Okun in: Particle Data Group, K. Hikasa *et al.*, Phys. Rev. D 45 (1992) VI.10
- [27] A.A. Klimenko *et al.*, Phys. Lett. B 535 (2002) 77
- [28] F.X. Hartmann and R.A. Naumann, Phys. Rev. C 31 (1985) 1594

Table 2. γ lines observed in the indium and background spectra. Intensities are expressed as number of γ 's per nucleus decay. Efficiencies refer to the four detectors (in OR) and are evaluated by cubic spline interpolation.

Database lines				ε (%)	Indium spectrum		Background spectrum		Difference c/day
Energy (keV)	Decay	Chain	Intensity (%)		Position (keV)	Rate c/day	Position (keV)	Rate c/day	
238.63	^{212}Pb	^{232}Th	43.3	2.55	238.34	6.03 ± 1.00	238.64	6.00 ± 0.87	0.03 ± 1.33
242.00	^{214}Pb	^{238}U	7.43	2.59	241.84	2.99 ± 0.70	241.70	3.30 ± 0.63	-0.30 ± 0.95
295.22	^{214}Pb	^{238}U	19.3	3.08	295.16	5.37 ± 0.82	295.23	4.47 ± 0.93	0.90 ± 1.24
300.01	^{227}Th	^{235}U	2.32	3.11	299.46	0.82 ± 0.63	300.73	0.69 ± 0.51	0.13 ± 0.81
300.07	^{212}Pb	^{232}Th	3.28	3.11					
338.32	^{228}Ac	^{232}Th	11.27	3.27	338.33	1.20 ± 0.43	337.95	1.41 ± 0.48	-0.21 ± 0.65
351.06	^{211}Bi	^{235}U	12.91	3.30	351.88	8.79 ± 0.47	351.88	10.31 ± 0.96	-1.51 ± 1.07
351.93	^{214}Pb	^{238}U	37.6	3.30					
				3.32	497.48 ± 0.21	0.78 ± 0.19	-	<0.34 (90% CL)	-
510.77	^{208}Tl	^{232}Th	22.6	3.31	510.83	4.50 ± 0.34	510.65	4.20 ± 0.51	0.30 ± 0.67
510.99	e^+ ann	*		3.31					
<i>(continued)</i>									

Database lines				ε (%)	Indium spectrum		Background spectrum		Difference c/day
Energy (keV)	Decay	Chain	Intensity (%)		Position (keV)	Rate c/day	Position (keV)	Rate c/day	
569.70	^{211}Po	^{235}U	0.5	3.25	570.11	0.71 ± 0.24	570.36	0.57 ± 0.18	0.14 ± 0.30
569.70	^{207}Bi	*	97.7	3.25					
583.19	^{208}Tl	^{232}Th	84.5	3.23	583.18	1.62 ± 0.19	583.53	1.80 ± 0.27	-0.18 ± 0.33
609.31	^{214}Bi	^{238}U	46.1	3.19	609.29	7.07 ± 0.28	609.27	6.96 ± 0.36	0.12 ± 0.45
661.66	^{137}Cs	*	85.1	3.13	661.76	4.34 ± 0.26	661.27	4.05 ± 0.30	0.29 ± 0.40
727.33	^{212}Bi	^{232}Th	6.58	3.06	727.20	0.91 ± 0.28	727.15	0.47 ± 0.33	0.44 ± 0.43
768.36	^{214}Bi	^{238}U	4.96	3.02	767.69	0.73 ± 0.36	768.04	0.45 ± 0.18	0.28 ± 0.41
794.95	^{228}Ac	^{232}Th	4.25	2.99	794.93	0.56 ± 0.21	-	<0.67 (90% CL)	-
803.10	$^{206}\text{Pb}^*$	*		2.98	803.11	0.71 ± 0.23	803.17	1.17 ± 0.33	-0.46 ± 0.40
834.84	^{54}Mn	*	100.0	2.95	834.82	0.73 ± 0.19	835.44	0.75 ± 0.18	-0.02 ± 0.26
835.71	^{228}Ac	^{232}Th	1.61	2.95					
839.04	^{214}Pb	^{238}U	0.59	2.95	840.89	0.50 ± 0.15	839.72	0.36 ± 0.18	0.14 ± 0.23
840.37	^{228}Ac	^{232}Th	0.91	2.95					
860.56	^{208}Tl	^{232}Th	12.42	2.93	859.29	0.64 ± 0.43	861.34	0.51 ± 0.39	0.13 ± 0.58
911.20	^{228}Ac	^{232}Th	25.8	2.87	911.30	1.79 ± 0.16	911.16	1.70 ± 0.35	0.09 ± 0.38
<i>(continued)</i>									

Database lines				ε (%)	Indium spectrum		Background spectrum		Difference c/day
Energy (keV)	Decay	Chain	Intensity (%)		Position (keV)	Rate c/day	Position (keV)	Rate c/day	
934.10	^{214}Bi	^{238}U	3.03	2.85	933.68	0.40 ± 0.14	934.53	0.21 ± 0.21	0.19 ± 0.25
964.76	^{228}Ac	^{232}Th	4.99	2.82	963.60	0.41 ± 0.19	964.44	0.27 ± 0.12	0.15 ± 0.23
968.97	^{228}Ac	^{232}Th	15.8	2.81	969.17	1.16 ± 0.26	968.95	0.84 ± 0.18	0.32 ± 0.32
1001.03	^{234m}Pa	^{238}U	0.84	2.78	1001.00	0.35 ± 0.14	1001.43	0.30 ± 0.15	0.05 ± 0.20
1063.66	^{207}Bi	*	74.5	2.73	1063.35	0.78 ± 0.14	1063.69	0.90 ± 0.15	-0.12 ± 0.20
1120.29	^{214}Bi	^{238}U	15.1	2.68	1120.27	1.46 ± 0.12	1119.91	1.56 ± 0.18	-0.10 ± 0.22
1124.00	$^{65}\text{Zn} + \text{Cu } K_{\alpha}$	*	50.6	2.68	1124.09	0.89 ± 0.10	1124.02	0.96 ± 0.12	-0.07 ± 0.16
1173.24	^{60}Co	*	99.97	2.65	1173.20	4.92 ± 0.32	1173.22	4.56 ± 0.48	0.36 ± 0.58
1238.11	^{214}Bi	^{238}U	5.79	2.61	1238.12	0.72 ± 0.21	1237.81	0.84 ± 0.21	-0.12 ± 0.30
1332.50	^{60}Co	*	99.99	2.53	1332.62	4.88 ± 0.32	1332.16	4.52 ± 0.45	0.36 ± 0.55
1377.67	^{214}Bi	^{238}U	4.00	2.49	1377.53	0.44 ± 0.14	1377.59	0.39 ± 0.06	0.05 ± 0.15
1407.98	^{214}Bi	^{238}U	2.15	2.46	1408.22	0.45 ± 0.24	1408.25	0.48 ± 0.30	-0.03 ± 0.39
1460.83	^{40}K	*	11.0	2.42	1460.92	18.14 ± 0.60	1460.94	18.55 ± 0.84	-0.4 ± 1.0
1509.23	^{214}Bi	^{238}U	2.11	2.38	1509.02	0.24 ± 0.14	1508.86	0.24 ± 0.06	0.00 ± 0.15
1588.19	^{228}Ac	^{232}Th	3.22	2.31	1588.02	0.24 ± 0.11	-	< 0.36 (90% CL)	-
<i>(continued)</i>									

Database lines				ε (%)	Indium spectrum		Background spectrum		Difference c/day
Energy (keV)	Decay	Chain	Intensity (%)		Position (keV)	Rate c/day	Position (keV)	Rate c/day	
1729.60	^{214}Bi	^{238}U	2.92	2.19	1729.79	0.33 ± 0.10	1729.84	0.48 ± 0.12	-0.15 ± 0.16
1764.49	^{214}Bi	^{238}U	15.4	2.17	1764.49	1.58 ± 0.20	1764.00	1.78 ± 0.24	-0.21 ± 0.31
1770.24	^{207}Bi	*	6.87	2.17	1769.81	0.17 ± 0.04	1770.00	0.22 ± 0.07	-0.05 ± 0.08
1808.65	^{26}Al	*	99.8	2.14	1808.14	0.38 ± 0.09	1808.44	0.30 ± 0.09	0.08 ± 0.13
1847.42	^{214}Bi	^{238}U	2.11	2.11	1847.53	0.14 ± 0.07	1847.10	0.21 ± 0.09	-0.07 ± 0.11
2204.21	^{214}Bi	^{238}U	5.08	1.89	2203.29	0.30 ± 0.05	2203.37	0.33 ± 0.09	-0.03 ± 0.10
2447.86	^{214}Bi	^{238}U	1.57	1.75	2447.86	0.19 ± 0.09	-	< 0.27 (90% CL)	-
2614.54	^{208}Tl	^{232}Th	99.0	1.66	2614.16	0.90 ± 0.14	2615.08	0.64 ± 0.17	0.26 ± 0.22