

# NONSINGULAR POSITON AND COMPLEXITON SOLUTIONS FOR THE COUPLED KdV SYSTEM

H. C. HU<sup>1,2</sup>, BIN TONG<sup>1</sup> AND S. Y. LOU<sup>1,3</sup>

<sup>1</sup>*Department of Physics, Shanghai Jiao Tong University, Shanghai, 200030, P. R. China*

<sup>2</sup>*College of Science, University of Shanghai for Science and Technology, Shanghai, 200093, P. R. China*

<sup>3</sup>*Department of Physics, Ningbo University, Ningbo, 315211, P. R. China*

ABSTRACT. Taking the coupled KdV system as a simple example, analytical and non-singular complexiton solutions are firstly discovered in this letter for integrable systems. Additionally, the analytical and nonsingular positon-negaton interaction solutions are also firstly found for S-integrable model. The new analytical positon, negaton and complexiton solutions of the coupled KdV system are given out both analytically and graphically by means of the iterative Darboux transformations.

**PACS.02.30.Ik, 02.30.Jr, 05.45.Yv.**

## 1. INTRODUCTION

On the exact solutions of integrable models, there is a new classification way recently based on the property of the spectral parameter [1]: If the spectral parameter is positive, the related solution of the nonlinear system is called positon which is usually expressed by means of the triangle functions. If the spectral parameter is negative, the related solution of the nonlinear system is called negaton which is usually expressed with help of the hyperbolic functions. The term “positon” and “negaton” may be pursued back to Matveev et al [2, 3] though the singular solutions had been studied earlier [4]. The so-called complexiton, which is expressed by combinations of the triangle functions and the hyperbolic functions, is related to the complex spectral parameters. It is meaningful that the complexiton exists for *real* integrable systems. The most of known positon solutions are singular. For various important integrable systems such as the KdV equation there is no nonsingular positon found. The negaton can be both singular and nonsingular. Especially nonsingular negatons are just the usual solitons. The interaction solutions among positons and negatons have also been

studied recently[5, 6]. Unfortunately, except for a special C-integrable model, the STO (Sharma-Tass-Olver) model [5], in our knowledge, there is no known nonsingular positon-negaton interaction solution. Though the complexiton is proposed for several years, but up to now, one has not yet found a nonsingular complexiton solution for any (1+1)-dimensional integrable systems. In high dimensions, (2+1)- and (3+1)-dimensions, some special types of analytic nonsingular positon, posil-ton-negaton interaction solutions and the complexiton solutions can be easily obtained because of the existence of the arbitrary functions in their expressions of exact solutions[7, 8].

Then an important and interesting question is naturally arised:

*Are there any nonsingular complexiton and positon-negaton solutions for S-integrable models?*

As we all know, the Korteweg-de Vries (KdV) equation is a typical and classical model to describe the weakly shallow long waves in the soliton theory. Many important properties of KdV equation, such as infinitely many symmetries, infinitely many conservation laws [9], inverse scattering transform, Bäcklund transformation, Darboux transformation, etc. have been studied extensively for a long time and it can be viewed as a completely integrable Hamiltonian system [10, 11]. Nevertheless, it is known that both the positon and complexiton solutions of the KdV equation are singular[2, 1].

On the other hand, coupled integrable systems, which come up in many physical fields, have also been studied extensively and a lot of interesting results are given out from both the classification view and application field [12]. The first coupled KdV system was put forward by Hirota and Satsuma (HS) in 1981 [13]. The multi-soliton solutions, conservation laws and Darboux transformation, etc for the HS model are studied in detail [14]. Many other coupled KdV systems such as the Ito's system [15], the Drinfeld and Sokolov [16] model, the Fuchssteiner equation [17], the Nutk-Oğuz model[18], the Zharkov system [19] and the Foursov model [20] are also constructed. Vladimir gives a classification of the integrable coupled KdV systems by using a symmetry approach [12].

In the real application aspect of the coupled KdV systems, a quite general coupled KdV equation,

$$\begin{aligned} u_t - 6uu_x + u_{xxx} + \epsilon_1vv_x + \epsilon_2(uv)_x + \epsilon_3v_{xxx} &= 0, \\ v_t - 6\beta vv_x + \beta v_{xxx} - V_0v_x + \alpha[\epsilon_1(vu)_x + \epsilon_2uu_x + \epsilon_3u_{xxx}] &= 0 \end{aligned} \quad (1)$$

where  $\epsilon_1$ ,  $\epsilon_2$ ,  $\epsilon_3$ ,  $\beta$  and  $V_0$  are arbitrary constants, is derived from a two-wave modes in a shallow stratified liquid [21].

Another type of general coupled KdV system

$$\begin{aligned} u_t + \alpha_1vu_x + (\alpha_2v^2 + \alpha_3uv + \alpha_4u_{xx} + \alpha_5u^2)_x &= 0, \\ v_t + \delta_1vu_x + (\delta_2u^2 + \delta_3uv + \delta_4v_{xx} + \delta_5v^2)_x &= 0, \end{aligned} \quad (2)$$

with arbitrary constants  $\alpha_i$ ,  $\delta_i$ ,  $i = 1, 2, \dots, 5$  is obtained from a two layer model of the atmospheric dynamical system [22].

A more general coupled KdV system

$$\partial_\tau q_j + \partial_\zeta \sum_{k,l} \gamma_j^{kl} q_k q_l + \partial_\zeta^3 \sum_k \beta_j^k q_k = 0, \quad j = 1, 2 \quad (3)$$

is derived to describe two-component Bose-Einstein condensates [23].

In this Letter, we study the exact solutions, especially the positons, negatons and complexitons of a special coupled KdV system

$$u_t + 6vv_x - 6uu_x + u_{xxx} = 0, \quad v_t - 6uv_x - 6vu_x + v_{xxx} = 0. \quad (4)$$

It is clear that the coupled KdV system (4) is a special case for all the physical systems (1), (2) and (3). It is also interesting that, the system (4) can be read off simply from the real and imaginary parts of the single complex KdV equation

$$U_t - 6UU_x + U_{xxx} = 0, \quad (5)$$

where

$$U = u + Iv, \quad I \equiv \sqrt{-1}.$$

From the fact that (4) can be derived from the complex KdV equation, one can reasonable believe that all the integrable properties of the real KdV equation can be preserved. Actually,

we have really proved its Painlevé property though we haven't write down the proof procedure here because the method is standard and even can be performed simply by pressing the “enter” key with help of some existent Maple or Mathematica programmes related to the Painlevé test, say, “Ptest” by Xu and Li [24].

In the remained part of this paper, we use the Darboux transformation which is one of the most powerful tools in constructing exact solutions for many integrable nonlinear equations to the coupled KdV system (4) to study its positon, negaton, complexiton solutions and the interaction property among these types of excitations.

## 2. LAX PAIR AND DARBOUX TRANSFORMATIONS OF THE COUPLED KdV SYSTEM (4).

In this section, we apply the Darboux transformation to the coupled KdV system (4) in order to construct exact solutions. Because the coupled KdV system is obtained by imposing complex variables on the KdV equation (5), we can easily obtain the Darboux transformation for the coupled KdV system (4) from those of the KdV equation.

It is known that the Lax pair for the KdV equation (5) reads

$$-\Phi_{xx} + U\Phi = \lambda\Phi, \quad (6)$$

$$\Phi_t = -4\Phi_{xxx} + 6U\Phi_x + 3U_x\Phi. \quad (7)$$

Substituting  $\Phi = \phi_1 - i\phi_2$  into Eqs. (6) and (7), the Lax pair for Eq. (4) is as follows:

$$\phi_{1xx} = v\phi_2 + u\phi_1 - \lambda\phi_1, \quad (8)$$

$$\phi_{2xx} = u\phi_2 - v\phi_1 - \lambda\phi_2, \quad (9)$$

and

$$\phi_{1t} = -4\phi_{1xxx} + 6v\phi_{2x} + 6u\phi_{1x} + 3v_x\phi_2 + 3u_x\phi_1, \quad (10)$$

$$\phi_{2t} = -4\phi_{2xxx} + 6u\phi_{2x} - 6v\phi_{1x} + 3u_x\phi_2 - 3v_x\phi_1, \quad (11)$$

then it is easy to prove that the compatibility conditions of four equations (8)–(11) are exactly the equation system (4).

With the help of the Darboux transformation for the KdV equation (5), we can easily obtain the first step Darboux transformation for the coupled KdV system

$$u[1] = u - \ln(f^2 + g^2)_{xx}, \quad (12)$$

$$v[1] = v - 2\arctan\left(\frac{g}{f}\right)_{xx}, \quad (13)$$

and the new wave functions are transformed to

$$\tilde{\phi}_1 = \phi_{1x} - \frac{\ln(f^2 + g^2)_x}{2}\phi_1 - \arctan\left(\frac{f}{g}\right)_x \phi_2, \quad (14)$$

$$\tilde{\phi}_2 = \phi_{2x} - \frac{\ln(f^2 + g^2)_x}{2}\phi_2 + \arctan\left(\frac{f}{g}\right)_x \phi_1, \quad (15)$$

where  $\{f, g\}$  is a wave function solution of the Lax pair (8)–(11) with  $\lambda = \lambda_0$ ,  $f = \phi_1$ ,  $g = \phi_2$ . In order to construct the second step Darboux transformation, we need two wave function seed solutions  $\{\phi_{11}, \phi_{12}\}$  and  $\{\phi_{21}, \phi_{22}\}$  with two different spectral parameters  $\lambda_1$  and  $\lambda_2$  respectively, then the second step Darboux transformation is

$$u[2] = u - [\ln(F^2 + G^2)]_{xx}, \quad (16)$$

$$v[2] = v - 2\left[\arctan\left(\frac{G}{F}\right)\right]_{xx}, \quad (17)$$

where two functions  $F$  and  $G$  are given by

$$F = W(\phi_{11}, \phi_{21}) - W(\phi_{12}, \phi_{22}), \quad (18)$$

and

$$G = -W(\phi_{11}, \phi_{22}) - W(\phi_{12}, \phi_{21}), \quad (19)$$

respectively with  $W(a, b) = ab_x - ba_x$  is the usual Wronskian determinant.

Similarly, the third and fourth step Darboux transformations are written down as follows simply,

$$u[3] = u - [\ln(H^2 + L^2)]_{xx}, \quad (20)$$

$$v[3] = v - 2 \left[ \arctan \left( \frac{L}{H} \right) \right]_{xx}, \quad (21)$$

where

$$H = W(\phi_{11}, \phi_{21}, \phi_{31}) - W(\phi_{11}, \phi_{22}, \phi_{32}) - W(\phi_{12}, \phi_{22}, \phi_{31}) - W(\phi_{12}, \phi_{21}, \phi_{32}),$$

and

$$L = W(\phi_{12}, \phi_{22}, \phi_{32}) - W(\phi_{12}, \phi_{21}, \phi_{31}) - W(\phi_{11}, \phi_{22}, \phi_{31}) - W(\phi_{11}, \phi_{21}, \phi_{32})$$

with  $\{\phi_{i1}, \phi_{i2}\} (i = 1, 2, 3)$  are solutions of the Lax pairs (8)–(11) with three different parameters  $\lambda_1, \lambda_2$  and  $\lambda_3$ . The fourth step Darboux transformation is more complicated because more wave functions are included in. The final results reads

$$u[4] = u - [\ln(P^2 + Q^2)]_{xx}, \quad (22)$$

$$v[4] = v - 2 \left[ \arctan \left( \frac{Q}{P} \right) \right]_{xx}, \quad (23)$$

where  $P \equiv P(x, t)$  and  $Q \equiv Q(x, t)$  are

$$\begin{aligned} P(x, t) &= W(\phi_{11}, \phi_{21}, \phi_{31}, \phi_{41}) + W(\phi_{12}, \phi_{22}, \phi_{32}, \phi_{42}) - W(\phi_{12}, \phi_{21}, \phi_{32}, \phi_{41}) \\ &\quad - W(\phi_{11}, \phi_{21}, \phi_{32}, \phi_{42}) - W(\phi_{12}, \phi_{22}, \phi_{31}, \phi_{41}) - W(\phi_{12}, \phi_{21}, \phi_{31}, \phi_{42}) \\ &\quad - W(\phi_{11}, \phi_{22}, \phi_{31}, \phi_{42}) - W(\phi_{11}, \phi_{22}, \phi_{32}, \phi_{41}), \end{aligned}$$

and

$$\begin{aligned} Q(x, t) &= W(\phi_{12}, \phi_{22}, \phi_{32}, \phi_{41}) + W(\phi_{12}, \phi_{21}, \phi_{32}, \phi_{42}) + W(\phi_{11}, \phi_{22}, \phi_{32}, \phi_{42}) \\ &\quad + W(\phi_{12}, \phi_{22}, \phi_{31}, \phi_{42}) - W(\phi_{11}, \phi_{21}, \phi_{32}, \phi_{41}) - W(\phi_{11}, \phi_{21}, \phi_{31}, \phi_{42}) \\ &\quad - W(\phi_{12}, \phi_{21}, \phi_{31}, \phi_{41}) - W(\phi_{11}, \phi_{22}, \phi_{31}, \phi_{41}), \end{aligned}$$

respectively, while  $\{\phi_{i1}, \phi_{i2}\}$ , ( $i = 1, 2, 3, 4$ ) are four wave function vector of the Lax pair (8)–(11) corresponding to four parameters  $\lambda_i$ , ( $i = 1, 2, 3, 4$ ).

In general, the  $N$ -step Darboux transformation for the coupled KdV system (4) is given by

$$u[N] = u - [\ln(W_r^2 + W_l^2)]_{xx}, \quad (24)$$

$$v[N] = v - 2 \left[ \arctan \left( \frac{W_r}{W_I} \right) \right]_{xx} \quad (25)$$

with  $W_r$  and  $W_I$  being the real and imaginary part of the Wronskian of the  $N$  complex wave functions

$$\Phi_i \equiv \phi_{i1} + I\phi_{i2}, \quad i = 1, 2, \dots, N,$$

i.e.,

$$W = W(\Phi_1, \Phi_2, \dots, \Phi_N) \equiv W_r + IW_I. \quad (26)$$

### 3. POSITON, NEGATON AND COMPLEXITON SOLUTIONS

In this section, we systematically study the positon, negaton and complexiton solutions for the coupled KdV system by means of the Darboux transformations given in the last section.

**3.1. Positon solution,  $\lambda > 0$ .** Based on the first step Darboux transformation, analytical positon solutions for the coupled KdV system can be constructed directly.

Taking the seed solution as  $\{u = 0, v = 0\}$ , then solving the Lax pair (8)-(11) directly, one can find

$$\begin{aligned} f &= \phi_1 = C_2 \sin(\sqrt{\lambda}x + 4\sqrt{\lambda^3}t) + C_1 \cos(\sqrt{\lambda}x + 4\sqrt{\lambda^3}t) \\ &= C_1 \cos(\sqrt{\lambda}x + 4\sqrt{\lambda^3}t + \delta_1) \equiv C_1 \cos \xi_1, \end{aligned} \quad (27)$$

$$\begin{aligned} g &= \phi_2 = C_4 \sin(\sqrt{\lambda}x + 4\sqrt{\lambda^3}t) + C_3 \cos(\sqrt{\lambda}x + 4\sqrt{\lambda^3}t) \\ &= C_3 \cos(\sqrt{\lambda}x + 4\sqrt{\lambda^3}t + \delta_2) \equiv C_3 \cos \xi_2. \end{aligned} \quad (28)$$

Substituting the result equations (27) and (28) into the first step Darboux transformation yields the single general positon solution for the coupled KdV system (4):

$$u = \frac{2\lambda [(C_1^2 - C_3^2)(C_1^2 \cos^2 \xi_1 - C_3^2 \cos^2 \xi_2) + 4C_1^2 C_3^2 \cos(\delta_1 - \delta_2) \cos \xi_1 \cos \xi_2]}{(C_1^2 \cos^2 \xi_1 + C_3^2 \cos^2 \xi_2)^2}, \quad (29)$$

$$v = \frac{4C_1 C_3 \lambda [(C_1^2 \cos^2 \xi_1 - C_3^2 \cos^2 \xi_2) \cos(\delta_1 - \delta_2) - (C_1^2 - C_3^2) \cos \xi_1 \cos \xi_2]}{(C_1^2 \cos^2 \xi_1 + C_3^2 \cos^2 \xi_2)^2}. \quad (30)$$

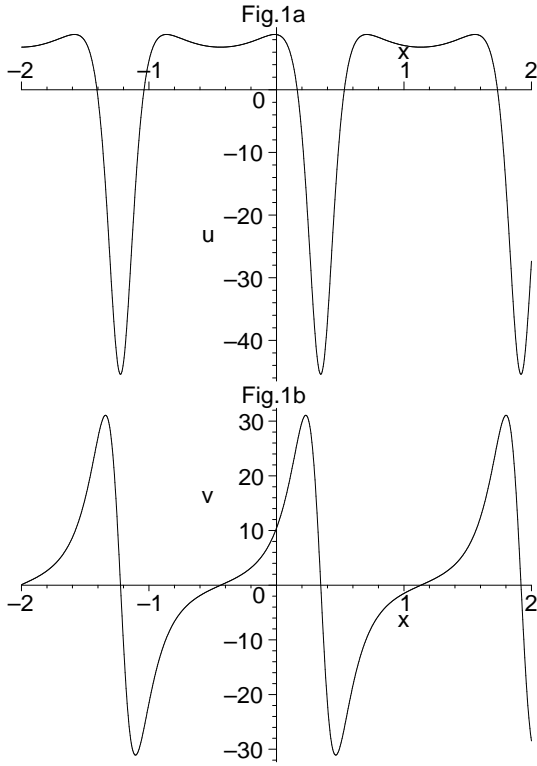

FIGURE 1. Structure of the Positon solution (a) for the field  $u$  expressed by (29) and (b) for the quantity  $v$  given by (30) with the parameter selections (31) at time  $t = 0$ .

It is easy to find that the positon solution (29)–(30) is always nonsingular for  $v \neq 0$ . Actually, from (29)–(30) we know that the positon is singular only for

$$\delta_2 = \delta_1 + n\pi, \quad n = 0, \pm 1, \pm 2, \dots,$$

while this constant condition leads to  $v = 0$ . This result coincides with the fact that the positon of the real KdV is singular.

Fig. 1 shows the nonsingular positon structure (29)–(30) with the constant parameter selections

$$C_1 = 2, \quad C_3 = 4, \quad \delta_1 = 0, \quad \delta_2 = 1, \quad \lambda = 4 \quad (31)$$

at time  $t = 0$ .

From Fig. 1, and the expressions (29) and (30), we know that a nonsingular positon is just a special nonsingular periodic wave solution.



**3.2. Negaton solution** ( $\lambda = -k^2 < 0$ ). In order to obtain the negaton solutions for coupled KdV system (4), we only need to substitute  $\lambda = -k^2$  into Eqs. (27) and (28), then the wave functions are

$$\begin{aligned} f &= C_2 e^{kx-4k^3t} + C_1 e^{-kx+4k^3t} \\ &= c_1 \sinh(kx - 4k^3t + \Delta_1) \equiv c_1 \sinh \eta_1, \end{aligned} \quad (32)$$

$$\begin{aligned} g &= C_4 e^{kx-4k^3t} + C_3 e^{-kx+4k^3t} \\ &= c_2 \sinh(kx - 4k^3t + \Delta_2) \equiv c_2 \sinh \eta_2. \end{aligned} \quad (33)$$

Substituting the above wave functions into the expressions of the first step Darboux transformation, we have the single negaton solution for the coupled KdV system (4)

$$u = \frac{2k^2 [(c_1^2 - c_2^2)(c_1^2 \sinh^2 \eta_1 - c_2^2 \sinh^2 \eta_2) + 4c_1^2 c_2^2 \cosh(\Delta_1 - \Delta_2) \sinh \eta_1 \sinh \eta_2]}{(c_1^2 \sinh^2 \eta_1 + c_2^2 \sinh^2 \eta_2)^2}, \quad (34)$$

$$v = \frac{2c_1 c_2 k^2 [(c_1^2 \sinh(2\eta_1) + c_2^2 \sinh(2\eta_2)) \sinh(\Delta_1 - \Delta_2)]}{(c_1^2 \sinh^2 \eta_1 + c_2^2 \sinh^2 \eta_2)^2}. \quad (35)$$

Fig. 2 shows a special negaton structure under the parameter selections

$$c_1 = 1, \quad c_2 = 5, \quad \Delta_1 = 0, \quad \Delta_2 = -2, \quad k = 2 \quad (36)$$

at time  $t = 0$ .

From the negaton expression (34)–(35), one can see that the negaton solution of the model is nonsingular except that  $\Delta_2 = \Delta_1 + n\pi\sqrt{-1}$  ( $n = 0, \pm 1, \pm 2, \dots$ ) which is corresponding to the real KdV case,  $v = 0$ .

**3.3. Negaton interaction solutions.** With the N-step Darboux transformations, one may obtain much richer solution structures including the interactions among different types of localized excitations. A type of soliton solution including two negatons can be constructed easily from the two-step Darboux transformation. Let two wave function vectors,  $\{\phi_{11}, \phi_{12}\}$  and  $\{\phi_{21}, \phi_{22}\}$ , are solutions of the Lax pair (8)–(11) with the seed  $\{u = 0, v = 0\}$  and two spectral parameters  $\{\lambda_1 = -k_1^2, \lambda_2 = -k_2^2\}$  respectively, then we have the two negaton

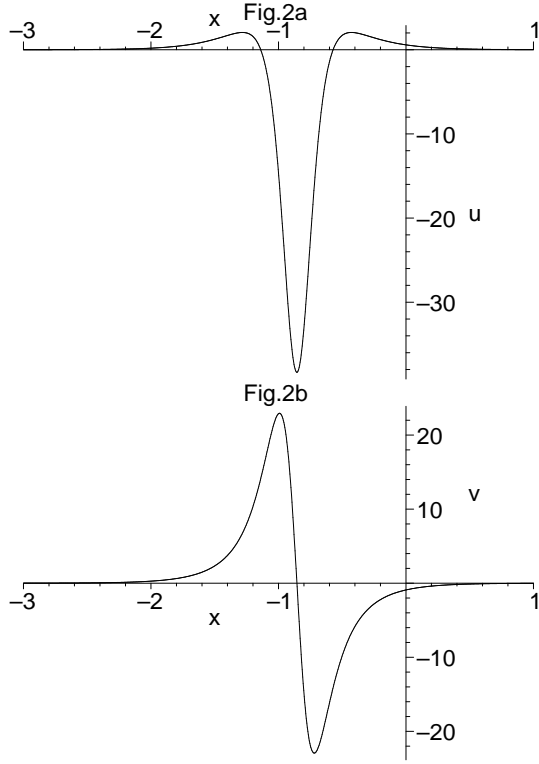

FIGURE 2. A typical negaton structure of the coupled KdV system (4) (a) for  $u$  expressed by (34) and (b) for  $v$  given by (35) under the parameter selections (36) at time  $t = 0$ .

solution expressed by (16)–(19) with

$$\phi_{11} = c_1 \cosh(k_1 x - 4k_1^3 t + \delta_1), \quad (37)$$

$$\phi_{12} = c_2 \cosh(k_1 x - 4k_1^3 t + \delta_2), \quad (38)$$

$$\phi_{21} = c_3 \cosh(k_2 x - 4k_2^3 t + \delta_3), \quad (39)$$

$$\phi_{22} = c_4 \cosh(k_2 x - 4k_2^3 t + \delta_4). \quad (40)$$

Fig. 3 and Fig.4 display the special two-negaton interaction procedure for the fields  $u$  and  $v$  described by (16)–(19) with zero seed, wave function selections (37)–(40) and the parameter selections

$$\delta_1 = 0, \quad c_1 = k_1 = \delta_2 = 1, \quad k_2 = 2, \quad c_2 = \delta_3 = 3, \quad \delta_4 = 4, \quad c_3 = c_4 = 5 \quad (41)$$

at times  $t = -0.25, 0.05, 0.1,$  and  $0.35$  respectively.

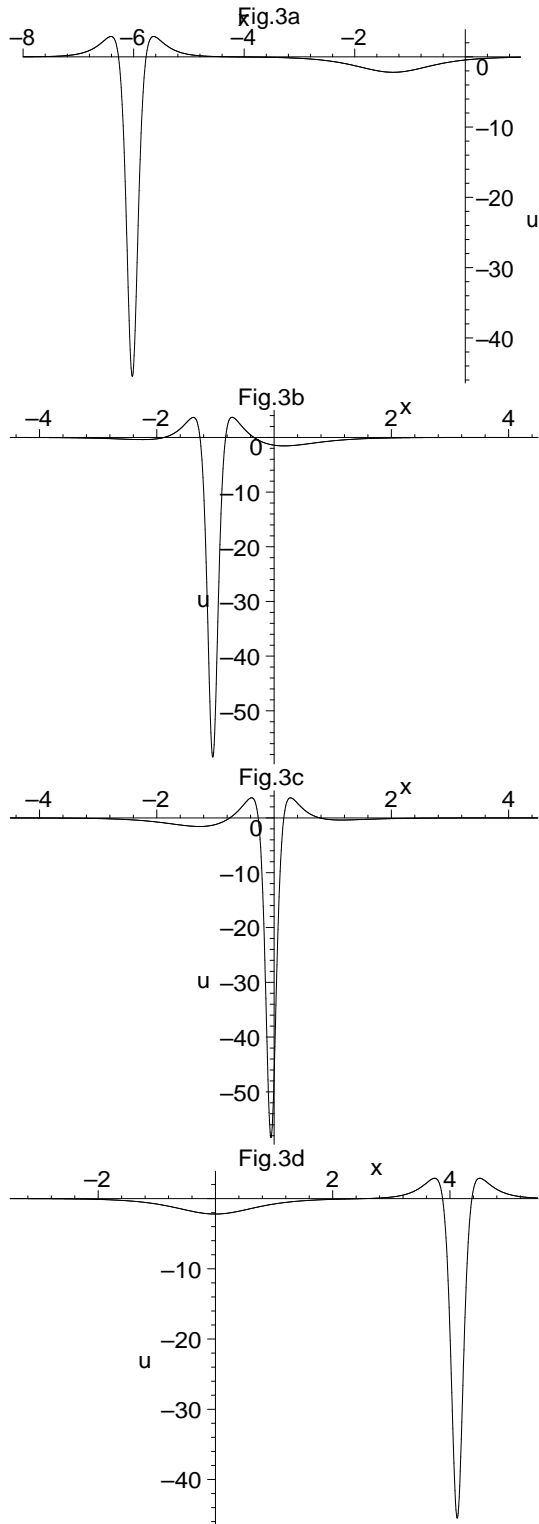

FIGURE 3. Negaton interaction solution expressed by (16)–(19) with zero seed, wave function selections (37)–(40) and the parameter selections (41) for the field  $u$  at times (a)  $t = -0.25$ ; (b)  $0.05$ ; (c)  $0.1$  and (d)  $0.35$  respectively.

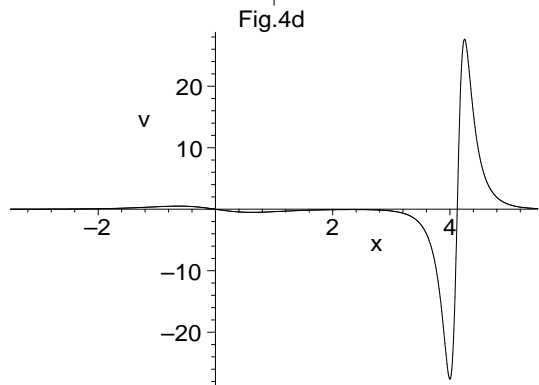
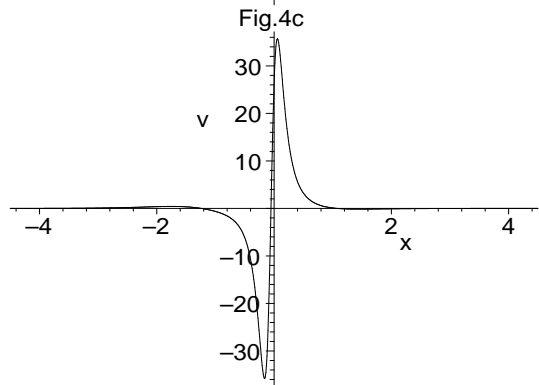
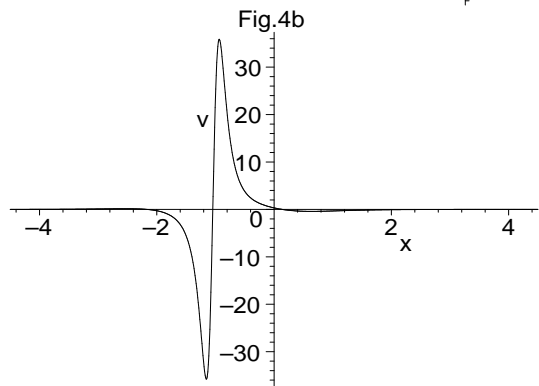
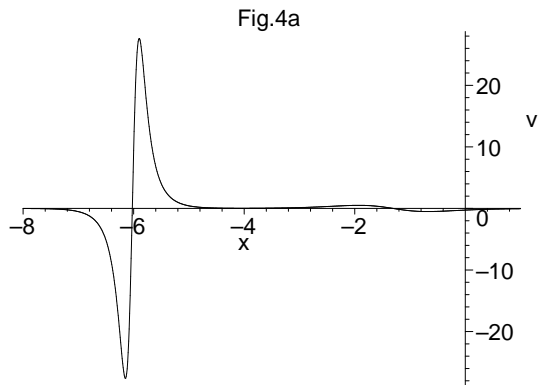

FIGURE 4. Negaton interaction solution for the quantity  $v$  with the same wave function and parameter selections as Fig. 3

Fig.5

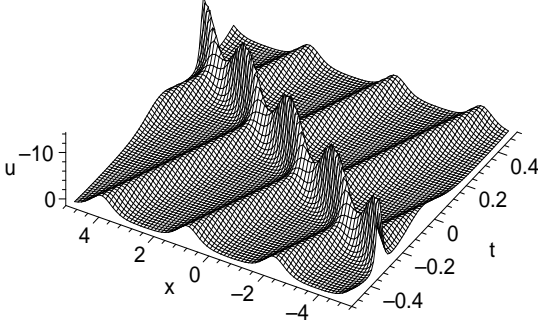

FIGURE 5. Positon-negaton interaction solution expressed by (16) and (18)-(19), (42)-(45) for the coupled KdV system (4).

**3.4. Positon-negaton interaction solution.** In the same way, by selecting the spectral parameters appropriately in the N-step Darboux transformations one can obtain the interaction solutions among positons and negatons. For instance, based on the second step Darboux transformation by choosing two different spectral parameters with opposite sign,  $\lambda_1 = \kappa^2$ ,  $\lambda_2 = -k^2$ , then we can obtain the positon-negaton interaction solutions for the coupled KdV system (4).

To show a concrete example, we further fix the spectral parameters as  $\lambda_1 = 1$ ,  $\lambda_2 = -4$  and select the corresponding spectral functions in the forms

$$\phi_{11} = 4 \sin(x + 4t) + 3 \cos(x + 4t), \quad (42)$$

$$\phi_{12} = 2 \sin(x + 4t) - 6 \cos(x + 4t). \quad (43)$$

$$\phi_{21} = 4e^{-2x+32t} + e^{2x-32t}, \quad (44)$$

$$\phi_{22} = 4e^{-2x+32t} + 0.01e^{2x-32t}. \quad (45)$$

Substituting (42)-(45) and (18)-(19) into (16)-(17) with the initial seed solution  $\{u = 0, v = 0\}$ , a special positon-negaton solution follows immediately. Fig. 6 and Fig. 7 show the interaction procedure expressed by (16)-(19), (42)-(45) and the initial solution  $\{u = 0, v = 0\}$  for the fields  $u$  and  $v$  respectively.

Fig.6

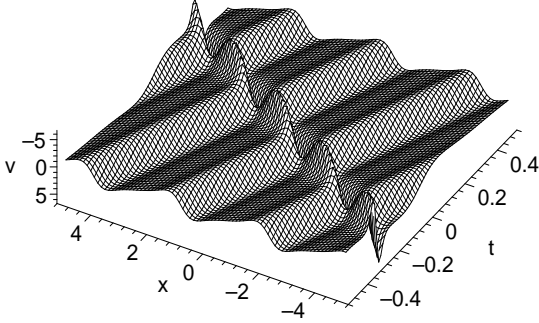

FIGURE 6. Positon-negaton solution expressed by (17)-(19), (42)-(45) for the coupled KdV system (4).

**3.5. Analytical complexiton solution.** For many integrable system, complexiton solutions have been found [1]. But it should be pointed out that the known complexiton solutions have singularities. It is lucky that the analytical complexiton solutions are found in this Letter for the first time. Let two spectral parameters  $\lambda$  and  $\lambda'$  be conjugated complex number, that is  $\lambda = \lambda_1 + I\lambda_2$  and  $\lambda' = \lambda_1 - I\lambda_2$ , then we arrive at two coupled wave solutions with the initial solution  $\{u = 0, v = 0\}$ ,

$$\phi_{11} = IC_1 e^{(4I\lambda_1^3 - 12\lambda_1^2\lambda_2 - 12I\lambda_1\lambda_2^2 + 4\lambda_2^3)t + (\lambda_1 I - \lambda_2)x} + IC_2 e^{(12\lambda_1^2\lambda_2 - 4I\lambda_1^3 + 12I\lambda_1\lambda_2^2 - 4\lambda_2^3)t + (\lambda_2 - I\lambda_1)x}, \quad (46)$$

$$\phi_{12} = IC_3 e^{(4I\lambda_1^3 - 12\lambda_1^2\lambda_2 - 12I\lambda_1\lambda_2^2 + 4\lambda_2^3)t + (\lambda_1 I - \lambda_2)x} + IC_4 e^{(12\lambda_1^2\lambda_2 - 4I\lambda_1^3 + 12I\lambda_1\lambda_2^2 - 4\lambda_2^3)t + (\lambda_2 - I\lambda_1)x}, \quad (47)$$

$$\phi_{21} = c_1 e^{(4I\lambda_1^3 + 12\lambda_1^2\lambda_2 - 12I\lambda_1\lambda_2^2 - 4\lambda_2^3)t + (\lambda_1 I + \lambda_2)x} + c_2 e^{(-I\lambda_1 - \lambda_2)x + (12I\lambda_1\lambda_2^2 + 4\lambda_2^3 - 4I\lambda_1^3 - 12\lambda_1^2\lambda_2)t}, \quad (48)$$

$$\phi_{22} = c_3 e^{(4I\lambda_1^3 + 12\lambda_1^2\lambda_2 - 12I\lambda_1\lambda_2^2 - 4\lambda_2^3)t + (\lambda_1 I + \lambda_2)x} + c_4 e^{(-I\lambda_1 - \lambda_2)x + (12I\lambda_1\lambda_2^2 + 4\lambda_2^3 - 4I\lambda_1^3 - 12\lambda_1^2\lambda_2)t}. \quad (49)$$

Substituting (46)-(49) into (18)-(19), we can obtain

$$\begin{aligned} F &= 4\lambda_2(c_1 C_1 - c_3 C_3) \sin[2\lambda_1(4t\lambda_1^2 + x - 12t\lambda_2^2)] \\ &\quad + 4\lambda_1(c_4 C_3 - c_2 C_1) \cosh[2\lambda_2(x + 12t\lambda_1^2 - 4t\lambda_2^2)], \end{aligned} \quad (50)$$

$$\begin{aligned} G &= -4\lambda_2(c_3 C_1 + c_1 C_3) \sin[2\lambda_1(4t\lambda_1^2 + x - 12t\lambda_2^2)] \\ &\quad + 4\lambda_1(c_2 C_3 + c_4 C_1) \cosh[2\lambda_2(x + 12t\lambda_1^2 - 4t\lambda_2^2)], \end{aligned} \quad (51)$$

where  $\{c_1, c_2, c_3, c_4, C_1, C_2, C_3, C_4, \lambda_1, \lambda_2\}$  are all constants. To show a detailed structure of the complexiton, we fix the constant parameters further. The substitution of (50) and (51) into (16)-(17) with the fixing constants  $\{c_1 = 5, c_2 = 0, c_3 = 0, c_4 = 5, C_1 = -1, C_2 = 2, C_3 = 2, C_4 = 1, \lambda_1 = 2, \lambda_2 = \frac{1}{2}\}$ , yields the following analytical nonsingular complexiton solution

$$U = - [\ln(F^2 + G^2)]_{xx} = \frac{A(x, t)}{B(x, t)} \quad (52)$$

and

$$V = -2 \left[ \arctan \left( \frac{G}{F} \right) \right]_{xx} = \frac{C(x, t)}{B(x, t)}, \quad (53)$$

where

$$\begin{aligned} A(x, t) &= -[272 \cos(104t + 8x) + 240 + 240 \cos(104t + 8x) \cosh(2x + 94t) \\ &\quad + 272 \cosh(2x + 94t) - 128 \sin(104t + 8x) \sinh(2x + 94t)], \\ B(x, t) &= \frac{835}{8} - \frac{17}{2} \cos(104t + 8x) + \frac{1}{8} \cos(208t + 16x) + 136 \cosh(2x + 94t) \\ &\quad - 8 \cos(104t + 8x) \cosh(2x + 94t) + 32 \cosh(4x + 188t), \end{aligned}$$

and

$$\begin{aligned} C(x, t) &= -[1862 \sin(52t + 4x) \cosh(x + 47t) + 30 \cosh(x + 47t) \sin(156t + 12x) \\ &\quad + 240 \cos(52t + 4x) \sinh(x + 47t) + 16 \sinh(x + 47t) \cos(156t + 12x) \\ &\quad + 480 \sin(52t + 4x) \cosh(3x + 141t) + 256 \cos(52t + 4x) \sinh(3x + 141t)]. \end{aligned}$$

The complexiton solution displayed above is analytical without any singularity and it is the first time to find this type of analytical complexiton solutions for the integrable systems to our knowledge. Fig. 7 and Fig. 8 show the detailed structures of the fields  $u$  and  $v$  expressed by (52) and (53) respectively.

#### 4. SUMMARY AND DISCUSSION

In this Letter, exact solutions of a coupled KdV system which is obtained as a special case of the general coupled KdV systems derived from the two layer fluid dynamical systems and two-component Bose-Einstein condensates are studied in detail. The model can also be

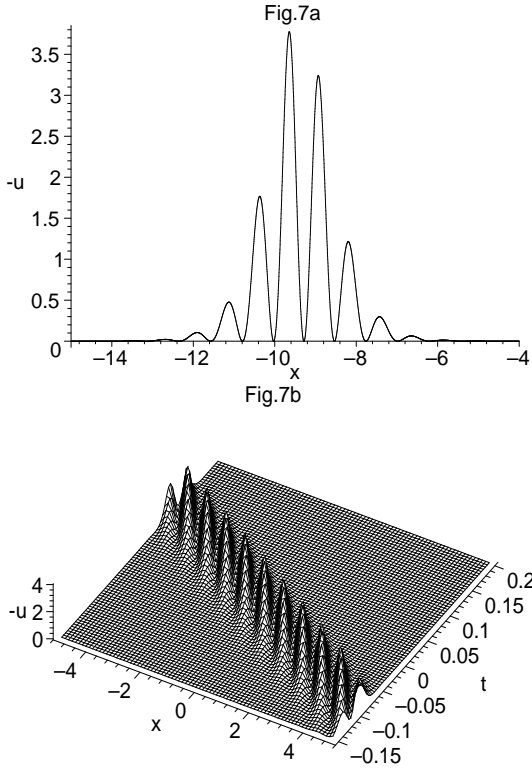

FIGURE 7. Analytical complexiton solution expressed by (52) for the coupled KdV system (4). (a) The structure plot at the fixed time  $t = 0.2$ ; (b) The evolution plot.

simply read off from the well known single KdV equation by assuming its field is complex. Thanks to the model can be obtained from the complex KdV equation, the Lax pair of the coupled KdV system follows immediately and so does the Darboux transformation.

To study the detailed structures of the localized and periodic excitations of the model, the first four step Darboux transformations are explicitly given in terms of the real Wronskian determinant forms while the general  $N$ -step Darboux transformation is written down with help of the complex Wronskian determinant form.

Starting from the trivial seed solution, the first step of the Darboux transformation leads to two types of exact solutions, the negaton and the positon which are related to negative and positive spectral parameters respectively. Though the single negaton solution for other integrable models, say, the single real KdV system, can be both singular and nonsingular,



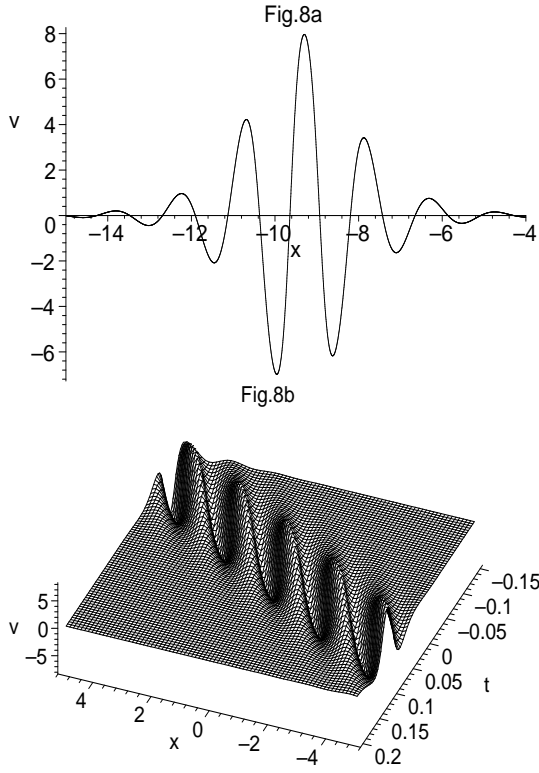

FIGURE 8. Nonsingular complexiton solution given by (53) for the coupled KdV system (4). (a) The structure plot at the fixed time  $t = 0.2$ ; (b) The evolution plot.

it can be only analytic for the coupled KdV system (4). Similarly, the positon solution can also be only analytic while for the single real KdV equation there is no analytic positon.

The solutions obtained from the second step Darboux transformation and the trivial zero seed can be two negaton interaction solution, two positon solution, negaton-positon solution and a single complexiton dependent on the selections of the spectral parameters. The interaction among negatons is completely elastic. The positon-negaton solution can be considered as a single soliton solution with a periodic wave background. The single real complexiton solution yields if two spectral parameters are complex conjugates. The known complexiton solutions for other integrable systems are singular[1]. It is interesting that the complexiton solution obtained here for the coupled KdV system is nonsingular! This type of nonsingular complexiton solution may exist for other types of coupled integrable systems.

Though the coupled KdV system studied here can be read off from the complex KdV equation, the solution properties are quite different. For the real single component KdV equation, there is no nonsingular positons and complexitons. However, for the coupled KdV system, negatons, positons and complexitons can be nonsingular.

For the single KdV system, various other types of exact solutions, such as the rational solutions, cnoidal wave solutions, algebraic geometry solutions and  $\tau$  function solutions have been obtained by many authors under different approaches. The similar solutions for the coupled KdV system (4) can be easily obtained in some similar ways. However, the detailed properties of the solutions, especially their analytic behavior, must be quite different. The more about the model and its possible applications in fluids, atmospheric dynamics and the Bose-Einstein condensates are worthy of studying further.

The authors are indebted to thanks Dr. X. Y. Tang and Prof. Y. Chen for their helpful discussions. The work was supported by the National Natural Science Foundation of China (No. 90203001 and No. 10475055).

#### REFERENCES

- [1] W. X. Ma, Phys. Lett. A 301 (2002) 35; W. X. Ma and K. Maruno, Physica A **343** (2004) 219.
- [2] V. B. Matveev and M. A. Salle *Darboux transformations and Solitons*, Springer-Verlag 1991; V. B. Matveev, Phys. Lett. A 166 (1992) 205; 209; 168 (1992) 463; J. Math. Phys. 35 (1994) 2955.
- [3] C. Rasinariu, U. Sukhatme and A. Khare, J. Phys. A: Math. Gen, 29 (1996) 1803.
- [4] M. D. Kruskal, Lect. Appl. Math. 15 (1974) 61; H. Airault, H. P. McKeon and J. Moser, Commun. Pure Appl. Math. 30 (1977) 95; M. J. Ablowitz and H. Cornille, Phys. Lett. A 72 (1979) 277.
- [5] Z. J. Lian and S. Y. Lou, Nonlinear Analysis, (2005) in press.
- [6] Y. Chen and Q. Wang, Phys. Lett. A. (2005) in press.
- [7] S. Y. Lou, H. C. Hu and X. Y. Tang, Phys. Rev. E., 71 (2005) 036604; H. C. Hu and S. Y. Lou, Phys. Lett. A 341 (2005) 422.
- [8] S. Y. Lou, Phys. Lett. A 277 (2000) 94; X. Y. Tang, S. Y. Lou and Y. Zhang, Phys. Rev. E., 66 (2002) 046601; H. C. Hu, X. Y. Tang, S. Y. Lou and Q. P. Liu, Chaos, Solitons and Fractals, 22 (2004) 327.
- [9] R. M. Miura, C. S. Gardner and M. D. Kruskal J. Math. Phys. **9** (1968) 1204; S. Y. Lou, J. Math. Phys. 35 (1994) 2390.
- [10] F. Magri J. Math. Phys. **19** (1978) 1156.
- [11] V. E. Zakharov and L. D. Faddeev, Functional Anal. Appl. **5** (1971) 280.
- [12] V. V. Sokolov and T. Wolf, J. Phys. A: Math. Gen. **34** (2001) 11139.  
V. V. Sokolov and S. I. Svinolupov, Theor. Math. Phys. **100** (1994) 959.
- [13] R. Hirota and J. Satsuma, Phys. Lett. A **85** (1981) 407.
- [14] R. Hirota and J. Satsuma, J. Phys. Soc. Japan **51** (1982) 3390.  
R. Dodd and A. P. Fordy Phys. Lett. A **89** (1982) 168.  
H. C. Hu and Q. P. Liu, Chaos, Solitons & Fractals **17** (2003) 921.
- [15] M. Ito, Phys. Lett. A **91** (1982) 335.

- [16] V. G. Drinfeld and V. V. Sokolov, *Sov. J. Math.* **30** (1985) 1975.
- [17] B. Fuchssteiner, *Prog. Theor. Phys.* **68** (1982) 1082.
- [18] Y. Nutku and O. Oğuz, *Nuovo Cimento Soc. Ital. Fis. B* **105** (1990) 1381.
- [19] A. Y. Zharkov, *J. Symb. Comput.* **15** (1993) 85.
- [20] M. V. Foursov, *Inverse Problems* **16** (2000) 259.
- [21] J. A. Gear and R. Grimshaw, *Stud. Appl. Math.* 70 (1984) 235; J. A. Gear, *Stud. Appl. Math.* 72 (1985) 95.
- [22] S. Y. Lou, B. Tong, H. C. Hu and X. Y. Tang, Coupled KdV equations derived from atmospherical dynamics, preprint ArXiv: nlin.SI/0508029.
- [23] V. A. Brazhnyi and V. V. Konotop, *Phys. Rev. E* 72 (2005) 026616.
- [24] G. Q. Xu and Z. B. Li, *Comp. Phys. Commun.* 161 (2004) 65.