

# PATHS, TABLEAUX, AND $q$ -CHARACTERS OF QUANTUM AFFINE ALGEBRAS: THE $C_n$ CASE

WAKAKO NAKAI<sup>1</sup> AND TOMOKI NAKANISHI<sup>2</sup>

*Graduate School of Mathematics, Nagoya University, Nagoya 464-8602, Japan*

ABSTRACT. For the quantum affine algebra  $U_q(\hat{\mathfrak{g}})$  with  $\mathfrak{g}$  of classical type, let  $\chi_{\lambda/\mu, a}$  be the Jacobi-Trudi type determinant for the generating series of the (supposed)  $q$ -characters of the fundamental representations. We conjecture that  $\chi_{\lambda/\mu, a}$  is the  $q$ -character of a certain finite dimensional representation of  $U_q(\hat{\mathfrak{g}})$ . We study the tableaux description of  $\chi_{\lambda/\mu, a}$  using the path method due to Gessel-Viennot. It immediately reproduces the tableau rule by Bazhanov-Reshetikhin for  $A_n$  and by Kuniba-Ohta-Suzuki for  $B_n$ . For  $C_n$ , we derive the explicit tableau rule for skew diagrams  $\lambda/\mu$  of three rows and of two columns.

## 1. INTRODUCTION

Let  $\mathfrak{g}$  be a simple Lie algebra over  $\mathbb{C}$  and  $\hat{\mathfrak{g}}$  be the corresponding non-twisted affine Lie algebra. Let  $U_q(\hat{\mathfrak{g}})$  be the quantum affine algebra, namely, the quantized universal enveloping algebra of  $\hat{\mathfrak{g}}$  [12, 17]. The  $q$ -character of  $U_q(\hat{\mathfrak{g}})$ , introduced in [15], is an injective ring homomorphism

$$\chi_q : \text{Rep}(U_q(\hat{\mathfrak{g}})) \rightarrow \mathbb{Z}[Y_{i,a}^{\pm 1}]_{i=1, \dots, n; a \in \mathbb{C}^\times},$$

where  $\text{Rep}(U_q(\hat{\mathfrak{g}}))$  is the Grothendieck ring of the category of the finite dimensional representations of  $U_q(\hat{\mathfrak{g}})$ . Like the usual character for  $\mathfrak{g}$ ,  $\chi_q(V)$  contains essential data of each representation  $V$ . Also, it is a powerful tool to investigate the ring structure of  $\text{Rep}(U_q(\hat{\mathfrak{g}}))$ . Unfortunately, not much is known about the explicit formula of  $\chi_q(V)$  so far.

The  $q$ -character is designed to be a “universalization” of the family of the transfer matrices of the solvable vertex models [5] associated to various  $R$ -matrices [6, 18, 19, 27]. The tableaux descriptions of the spectra of the transfer matrices of a vertex model associated to  $U_q(\hat{\mathfrak{g}})$  were studied in [7, 20, 22] for  $\mathfrak{g}$  of classical type. Then, one can interpret their results in the context of the  $q$ -character in the following way: Let  $\chi_{\lambda/\mu, a}$  be the Jacobi-Trudi determinant (2.23) for the generating series of the (supposed)  $q$ -characters of the fundamental representations of  $U_q(\hat{\mathfrak{g}})$ , where  $\lambda/\mu$  is a skew diagram and  $a \in \mathbb{C}$ . For  $A_n$  and  $B_n$ ,  $\chi_{\lambda/\mu, a}$  is conjectured to be the  $q$ -character of the finite dimensional irreducible representation of  $U_q(\hat{\mathfrak{g}})$  associated to  $\lambda/\mu$  and  $a$ . The determinant  $\chi_{\lambda/\mu, a}$  allows the description by the semistandard tableaux of

<sup>1</sup>e-mail: m99013c@math.nagoya-u.ac.jp

<sup>2</sup>e-mail: nakanisi@math.nagoya-u.ac.jp

shape  $\lambda/\mu$  for  $A_n$  [7], and by the tableaux of shape  $\lambda/\mu$  which satisfy certain “horizontal” and “vertical” rules similar to the rules of the semistandard tableaux for  $B_n$  [20] (see Definition 4.4 for the rules). For  $C_n$  and  $D_n$ , we still conjecture (Conjecture 2.2) that  $\chi_{\lambda/\mu,a}$  is the  $q$ -character of a certain, but not necessarily irreducible, representation of  $U_q(\hat{\mathfrak{g}})$ . However, the tableaux description for  $\chi_{\lambda/\mu,a}$  is known only for the basic cases,  $(\lambda, \mu) = ((1^i), \phi)$  and  $(\lambda, \mu) = ((i), \phi)$  [22, 21, 14].

The main purpose of the paper is to give the tableaux description of  $\chi_{\lambda/\mu,a}$  in the  $C_n$  case.

Let us preview our results and explain what makes the tableaux description more complicated for  $C_n$  and  $D_n$  than  $A_n$  and  $B_n$ . To obtain the tableaux description of  $\chi_{\lambda/\mu,a}$ , we apply the paths method of [16]. The method was originally introduced to derive the well-known semistandard tableaux description of the Schur function from the (original) Jacobi-Trudi determinant; but, the idea is applicable to our determinant  $\chi_{\lambda/\mu,a}$ , too. Roughly speaking, the method works as follows: First, we express the determinant by sequences of “paths”. Then, the contributions for the determinant from the intersecting sequences of paths cancel, and we obtain a positive sum expression of the determinant by the nonintersecting sequences of paths. Finally, we translate each nonintersecting sequence of paths into a “tableau”; the definition of a path and the nonintersecting property turn into the horizontal and vertical rules, respectively. For  $A_n$ , the method works perfectly, and it immediately reproduces the result of [7] above. For  $B_n$ , though a slight modification is required, it works well, too, and reproduces the result of [20] above. For  $C_n$  and  $D_n$ , however, it turns out that the contributions from the intersecting sequences of the paths does not completely cancel out, and we only get an *alternative* sum expression by nonintersecting and intersecting sequences of paths. Therefore, we need one more step to translate it into a *positive* sum expression by tableaux, and it can be done essentially by the inclusion-exclusion principle. Then, due to the negative contribution in the alternative sum, some additional rules emerge besides the horizontal and vertical rules, which we call the *extra* rules (see the two-row diagram case in Section 5.3 for the simplest example). It turns out, however, that these extra rules depend on the shape  $\lambda/\mu$ , and have infinitely many variety. This explains, at least in our point of view, why the tableaux description for  $C_n$  and  $D_n$  has not been known so far except for the basic cases.

The outline of the paper is as follows. In Section 2, we define the Jacobi-Trudi determinant  $\chi_{\lambda/\mu,a}$  (2.23) and formulate our basic conjecture (Conjecture 2.2) that  $\chi_{\lambda/\mu,a}$  is the  $q$ -character of an irreducible representation of  $U_q(\hat{\mathfrak{g}})$  (for  $C_n$  and  $D_n$ ,  $\mu = \phi$ ). In Sections 3 and 4 we show how the Gessel-Viennot method works well to reproduce the results of [7] for  $A_n$  and [20] for  $B_n$ . In Section 5 we consider the  $C_n$  case. This is the main part of the paper. As explained above, the Gessel-Viennot method only gives an alternative sum expression  $\chi_{\lambda/\mu,a}$  in terms of paths (Proposition 5.3). To

apply the inclusion-exclusion principle, we introduce the “resolution” of a transposed pair of paths, and derive the extra rules explicitly for the skew diagram of three rows (Theorem 5.7) and of two columns (Theorem 5.10 and Conjecture 5.9).

For general skew diagrams, the extra rules have infinitely many variety, and so far we have not found a unified way to write them down explicitly. However, the above examples suggest that, after all, the extra rules are better described *in terms of paths*. We plan to study it in a separate publication.

The  $D_n$  case is similar to  $C_n$ , and it will be treated also in a separate publication.

Let us briefly mention two possible applications of the results. Firstly, the affine crystal for the Kirillov-Reshetikhin representations, which are special cases of the representations treated here, are highly expected but known only for basic cases (See [29], for example). It is interesting to study if there is a natural affine crystal structure on our tableaux. Secondly, our tableaux are quite compatible with the conjectural algorithm of [13] to create the  $q$ -character. We hope that our tableaux help us to prove the algorithm for these representations, and also to prove Conjecture 2.2 itself.

We thank T. Arakawa and S. Okada for useful discussions.

## 2. $q$ -CHARACTERS AND THE JACOBI-TRUDI DETERMINANT

In this section, we give the conjecture of the Jacobi-Trudi type formula of the  $q$ -characters. Throughout the paper, we assume that  $q^k \neq 1$  for any  $k \in \mathbb{Z}$ .

**2.1. The variable  $Y_{i,a}^{\pm 1}$  and  $z_{i,a}$ .** The  $q$ -character is originally described as a polynomial in  $\mathbb{Z}[Y_{i,a}^{\pm 1}]_{i=1,\dots,n;a \in \mathbb{C}^\times}$  in [15], where  $Y_{i,a}$  is the affinization of the formal exponential  $y_i := e^{\omega_i}$  of the fundamental weight  $\omega_i$  in the character  $\chi : \text{Rep } U_q(\mathfrak{g}) \rightarrow \mathbb{Z}[y_i^{\pm 1}]_{i=1,\dots,n}$  of  $U_q(\mathfrak{g})$ , with the spectral parameter  $a \in \mathbb{C}^\times$ . For simplicity, we write the variable  $Y_{i,aq^k}^{\pm 1}$  [15] in a “logarithmic” form as  $Y_{i,a'+k}^{\pm 1}$ , where  $k \in \mathbb{Z}$ ,  $a' = \log_q a \in \mathbb{C}$  and  $q \in \mathbb{C}^\times$ . In this subsection, we transform the variables  $\{Y_{i,a}^{\pm 1}\}_{i=1,\dots,n;a \in \mathbb{C}}$  into new variables  $\{z_{i,a}\}_{i \in I;a \in \mathbb{C}}$ , which represent the monomials in the  $q$ -character of the first fundamental representation (see (2.14)).

Set

$$\mathcal{Y} = \begin{cases} \mathbb{Z}[Y_{1,a}^{\pm 1}, Y_{2,a}^{\pm 1}, \dots, Y_{n,a}^{\pm 1}]_{a \in \mathbb{C}}, & (A_n, C_n) \\ \mathbb{Z}[Y_{1,a}^{\pm 1}, Y_{2,a}^{\pm 1}, \dots, Y_{n-1,a}^{\pm 1}, Y_{n,a-1}^{\pm 1}, Y_{n,a+1}^{\pm 1}]_{a \in \mathbb{C}}, & (B_n) \\ \mathbb{Z}[Y_{1,a}^{\pm 1}, Y_{2,a}^{\pm 1}, \dots, Y_{n-2,a}^{\pm 1}, Y_{n-1,a}^{\pm 1}, Y_{n,a}^{\pm 1}, Y_{n,a-1}^{\pm 1}, Y_{n,a+1}^{\pm 1}]_{a \in \mathbb{C}}. & (D_n) \end{cases}$$

Let  $I$  be a set of letters,

$$(2.1) \quad I = \begin{cases} \{1, 2, \dots, n, n+1\}, & (A_n) \\ \{1, 2, \dots, n, 0, \bar{n}, \dots, \bar{2}, \bar{1}\}, & (B_n), \\ \{1, 2, \dots, n, \bar{n}, \dots, \bar{2}, \bar{1}\}, & (C_n, D_n). \end{cases}$$

Let  $\mathcal{Z}$  be the commutative ring over  $\mathbb{Z}$  generated by  $\{z_{i,a}\}_{i \in I; a \in \mathbb{C}}$ , with the following generating relations ( $a \in \mathbb{C}$ ) with  $z_{0,a} = z_{\bar{0},a} = 1$  in (2.4) and (2.5):

$$(2.2) \quad \prod_{k=1}^{n+1} z_{k,a-2k} = 1, \quad (A_n)$$

$$(2.3) \quad \begin{cases} z_{i,a} z_{\bar{i},a-4n+4i-2} = z_{i-1,a} z_{\overline{i-1},a-4n+4i-2} \quad (i = 2, \dots, n), \\ z_{1,a} z_{\bar{1},a-4n+2} = 1, \quad z_{0,a} = \prod_{k=1}^n z_{k,a+4n-4k} z_{\bar{k},a-4n+4k}, \end{cases} \quad (B_n)$$

$$(2.4) \quad z_{i,a} z_{\bar{i},a-2n+2i-4} = z_{i-1,a} z_{\overline{i-1},a-2n+2i-4} \quad (i = 1, \dots, n), \quad (C_n)$$

$$(2.5) \quad z_{i,a} z_{\bar{i},a-2n+2i} = z_{i-1,a} z_{\overline{i-1},a-2n+2i} \quad (i = 1, \dots, n). \quad (D_n)$$

We have

**Proposition 2.1.**  $\mathcal{Z}$  is isomorphic to  $\mathcal{Y}$  as a ring.

*Proof.* Let  $f : \mathcal{Z} \rightarrow \mathcal{Y}$  be a ring homomorphism defined as follows, with  $Y_{0,a} = 1$ , and in (2.6),  $Y_{n+1,a} = 1$ :

$$(2.6) \quad z_{i,a} \mapsto Y_{i,a+i-1} Y_{i-1,a+i}^{-1}, \quad i = 1, \dots, n+1, \quad (A_n)$$

$$(2.7) \quad \begin{cases} z_{i,a} \mapsto Y_{i,a+2i-2} Y_{i-1,a+2i}^{-1}, & i = 1, \dots, n-1, \\ z_{n,a} \mapsto Y_{n,a+2n-3} Y_{n-1,a+2n-1} Y_{n-1,a+2n}^{-1}, \\ z_{\bar{n},a} \mapsto Y_{n-1,a+2n-2} Y_{n,a+2n-1}^{-1} Y_{n,a+2n+1}^{-1}, \\ z_{\bar{i},a} \mapsto Y_{i-1,a+4n-2i-2} Y_{i,a+4n-2i}^{-1}, & i = 1, \dots, n-1, \end{cases} \quad (B_n)$$

$$(2.8) \quad \begin{cases} z_{i,a} \mapsto Y_{i,a+i-1} Y_{i-1,a+i}^{-1}, & i = 1, \dots, n, \\ z_{\bar{i},a} \mapsto Y_{i-1,a+2n-i+2} Y_{i,a+2n-i+3}^{-1}, & i = 1, \dots, n, \end{cases} \quad (C_n)$$

$$(2.9) \quad \begin{cases} z_{i,a} \mapsto Y_{i,a+i-1} Y_{i-1,a+i}^{-1}, & i = 1, \dots, n-2, \\ z_{n-1,a} \mapsto Y_{n,a+n-2} Y_{n-1,a+n-2} Y_{n-2,a+n-1}^{-1}, \\ z_{n,a} \mapsto Y_{n,a+n-2} Y_{n-1,a+n}^{-1}, \\ z_{\bar{n},a} \mapsto Y_{n-1,a+n-2} Y_{n,a+n}^{-1}, \\ z_{\overline{n-1},a} \mapsto Y_{n-2,a+n-1} Y_{n-1,a+n}^{-1} Y_{n,a+n}^{-1}, \\ z_{\bar{i},a} \mapsto Y_{i-1,a+2n-i-2} Y_{i,a+2n-i-1}^{-1}, & i = 1, \dots, n-2. \end{cases} \quad (D_n)$$

Let  $g : \mathcal{Y} \rightarrow \mathcal{Z}$  be the ring homomorphism defined as follows ( $a \in \mathbb{C}$ ):

$$(2.10) \quad \begin{cases} Y_{i,a} \mapsto \prod_{k=1}^i z_{k,a+i-2k+1}, & i = 1, \dots, n, \\ Y_{i,a}^{-1} \mapsto \prod_{k=i+1}^{n+1} z_{k,a+i-2k+1}, & i = 1, \dots, n, \end{cases} \quad (A_n)$$

$$(2.11) \quad \begin{cases} Y_{i,a} \mapsto \prod_{k=1}^i z_{k,a+2i-4k+2}, & i = 1, \dots, n-1, \\ Y_{n,a-1} Y_{n,a+1} \mapsto \prod_{k=1}^n z_{k,a+2n-4k+2}, \\ Y_{n,a-1}^{-1} Y_{n,a+1}^{-1} \mapsto \prod_{k=1}^n \bar{z}_{k,a-6n+4k}, \\ Y_{i,a}^{-1} \mapsto \prod_{k=1}^i \bar{z}_{k,a-4n-2i+4k}, & i = 1, \dots, n-1, \end{cases} \quad (B_n)$$

$$(2.12) \quad \begin{cases} Y_{i,a} \mapsto \prod_{k=1}^i z_{k,a+i-2k+1}, & i = 1, \dots, n, \\ Y_{i,a}^{-1} \mapsto \prod_{k=1}^i \bar{z}_{k,a-2n-i+2k-3}, & i = 1, \dots, n, \end{cases} \quad (C_n)$$

$$(2.13) \quad \begin{cases} Y_{i,a} \mapsto \prod_{k=1}^i z_{k,a+i-2k+1}, & i = 1, \dots, n-2, \\ Y_{n-1,a} Y_{n,a} \mapsto \prod_{k=1}^{n-1} z_{k,a+n-2k}, \\ Y_{n,a-1} Y_{n,a+1} \mapsto \prod_{k=1}^n z_{k,a+n-2k+1}, \\ Y_{n,a-1}^{-1} Y_{n,a+1}^{-1} \mapsto \prod_{k=1}^n \bar{z}_{k,a-3n+2k+1}, \\ Y_{n-1,a}^{-1} Y_{n,a}^{-1} \mapsto \prod_{k=1}^{n-1} \bar{z}_{k,a-3n+2k+2}, \\ Y_{i,a}^{-1} \mapsto \prod_{k=1}^i \bar{z}_{k,a-2n-i+2k+1}, & i = 1, \dots, n-2. \end{cases} \quad (D_n)$$

It is easy to check that each homomorphism is well defined and  $f \circ g = g \circ f = \text{id}$ , so that  $f$  and  $g$  are inverse to each other.  $\square$

From now, we identify  $\mathcal{Y}$  with  $\mathcal{Z}$  by the isomorphism  $f$ . Then, the  $q$ -character of the first fundamental representation  $V_{\omega_1}(q^a)$  is given as [15]

$$(2.14) \quad \chi_q(V_{\omega_1}(q^a)) = \sum_{i \in I} z_{i,a}.$$

**2.2. Partitions, Young diagrams, and tableaux.** A *partition* is a sequence of weakly decreasing non-negative integers  $\lambda = (\lambda_1, \lambda_2, \dots)$  with finitely many non-zero terms  $\lambda_1 \geq \lambda_2 \geq \dots \geq \lambda_l > 0$ . The *length*  $l(\lambda)$  of  $\lambda$  is the number of the non-zero integers in  $\lambda$ . The *conjugate* of  $\lambda$  is denoted by  $\lambda' = (\lambda'_1, \lambda'_2, \dots)$ . As usual, we identify a partition  $\lambda$  with a *Young diagram*  $\lambda = \{(i, j) \in \mathbb{N} \times \mathbb{N} \mid 1 \leq j \leq \lambda_i\}$ , and also identify a pair of partitions  $(\lambda, \mu)$  such that  $\mu \subset \lambda$ , i.e.,  $\lambda_i - \mu_i \geq 0$  for any  $i$ , with a *skew diagram*  $\lambda/\mu = \{(i, j) \in \mathbb{N} \times \mathbb{N} \mid \mu_i + 1 \leq j \leq \lambda_i\}$ . If  $\mu = \phi$ , we write a skew diagram

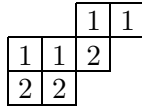

FIGURE 1. The highest weight tableau of  $\lambda/\mu$  for  $(\lambda, \mu) = ((4, 3, 2), (2))$ .

as a Young diagram  $\lambda$  instead of  $\lambda/\phi$ . The *depth*  $d(\lambda/\mu)$  of  $\lambda/\mu$  is the length of its longest column, i.e.,  $d(\lambda/\mu) = \max\{\lambda'_i - \mu'_i\}$ . A *tableau*  $T$  of shape  $\lambda/\mu$  is the skew diagram  $\lambda/\mu$  with each box filled by one entry of  $I$  (2.1).

For a tableau  $T$  and  $a \in \mathbb{C}$ , we define

$$(2.15) \quad z_a^T := \prod_{(i,j) \in \lambda/\mu} z_{T(i,j), a+2(j-i)\delta},$$

where  $T(i, j)$  is the entry of  $T$  at  $(i, j)$ , namely, the entry at the  $i$ th row and the  $j$ th column, and  $\delta$  is

$$(2.16) \quad \delta = \begin{cases} 1, & (A_n, C_n, D_n) \\ 2. & (B_n) \end{cases}$$

For any skew diagram  $\lambda/\mu$  with  $d(\lambda/\mu) \leq n$ , let  $T_+$  be the tableau of shape  $\lambda/\mu$  such that  $T(i, j) = i - \mu'_j$  for all  $(i, j) \in \lambda/\mu$ . We call  $T_+$  the *highest weight tableau* of  $\lambda/\mu$ . See Figure 1 for example. Then we have

$$(2.17) \quad f(z_a^{T_+}) = \prod_{j=1}^{l(\lambda')} Y_{\lambda'_j - \mu'_j, a(j)}^{1-\beta(j)} Y_{n, a(j)}^{\alpha(j)} Y_{n, a(j)-1}^{\beta(j)} Y_{n, a(j)+1}^{\beta(j)},$$

where  $f$  is the isomorphism in the proof of Proposition 2.1 and

$$\begin{aligned} a(j) &= a + (2j - \lambda'_j - \mu'_j - 1)\delta, \\ \alpha(j) &= \begin{cases} 1, & \text{if } \mathfrak{g} \text{ is of type } D_n \text{ and } \lambda'_j - \mu'_j = n - 1, \\ 0, & \text{otherwise,} \end{cases} \\ \beta(j) &= \begin{cases} 1, & \text{if } \mathfrak{g} \text{ is of type } B_n \text{ or } D_n \text{ and } \lambda'_j - \mu'_j = n, \\ 0, & \text{otherwise.} \end{cases} \end{aligned}$$

**2.3. Representations of  $U_q(\hat{\mathfrak{g}})$  associated to skew diagrams.** There is a bijection between the set of the isomorphism classes of the finite dimensional irreducible representations of  $U_q(\hat{\mathfrak{g}})$  and the set of  $n$ -tuples of polynomials [10, 11]

$$\mathbf{P}(u) = (P_i(u))_{i=1, \dots, n}, \quad P_i(u) \in \mathbb{C}[u] \text{ with constant term } 1,$$

which are called the *Drinfel'd polynomials*. Let  $V(\mathbf{P}(u))$  be the representation associated to  $\mathbf{P}(u)$ , where

$$P_i(u) = \prod_{k=1}^{n_i} (1 - uq^{a_{ik}}), \quad i = 1, \dots, n.$$

Then the  $q$ -character  $\chi_q(V(\mathbf{P}(u)))$  contains the *highest weight monomial*

$$(2.18) \quad m(\mathbf{P}(u)) := \prod_{i=1}^n \prod_{k=1}^{n_i} Y_{i, a_{ik}}$$

with multiplicity 1 [13].

For any skew diagram  $\lambda/\mu$  with  $d(\lambda/\mu) \leq n$ , one can uniquely associate a finite dimensional irreducible representation of  $U_q(\hat{\mathfrak{g}})$  such that its highest weight monomial (2.18) coincides with (2.17) for the highest weight tableau  $T_+$  of  $\lambda/\mu$ . We write this representation as  $V(\lambda/\mu, a)$ . Namely,  $V(\lambda/\mu, a)$  is the representation that corresponds to the Drinfel'd polynomial

$$\prod_{j=1}^{l(\lambda')} \mathbf{P}_{\lambda'_j - \mu'_j, a(j)}^{1-\beta(j)}(u) \mathbf{P}_{n, a(j)}^{\alpha(j)}(u) \mathbf{P}_{n, a(j)-1}^{\beta(j)}(u) \mathbf{P}_{n, a(j)+1}^{\beta(j)}(u),$$

where  $\mathbf{PQ} := (P_j Q_j)_{j=1, \dots, n}$  for any  $\mathbf{P} = (P_j)_{j=1, \dots, n}$  and  $\mathbf{Q} = (Q_j)_{j=1, \dots, n}$ , and  $\mathbf{P}_{i, a}^\gamma(u) = (P_j(u))_{j=1, \dots, n}$  is defined as

$$P_j(u) = \begin{cases} 1 - uq^a, & \text{if } j = i \text{ and } \gamma = 1, \\ 1, & \text{otherwise.} \end{cases}$$

**2.4. The Jacobi-Trudi formula for the  $q$ -characters.** Let  $\delta$  be the number in (2.16). Let  $\mathbb{Z}[[X]]$  be the formal power series ring over  $\mathbb{Z}$  with variable  $X$ . Let  $\mathcal{A}$  be the *non-commutative* ring generated by  $\mathcal{Z}$  and  $\mathbb{Z}[[X]]$  with relations

$$(2.19) \quad Xz_{i, a} = z_{i, a-2\delta}X, \quad i \in I, a \in \mathbb{C}.$$

For any  $a \in \mathbb{C}$ , we define  $E_a(z, X), H_a(z, X) \in \mathcal{A}$  as follows:

$$(2.20) \quad E_a(z, X) := \begin{cases} \overrightarrow{\prod}_{1 \leq k \leq n+1} (1 + z_{k, a}X) & (A_n) \\ \{\overrightarrow{\prod}_{1 \leq k \leq n} (1 + z_{k, a}X)\} (1 - z_{0, a}X)^{-1} \{\overleftarrow{\prod}_{1 \leq k \leq n} (1 + z_{\bar{k}, a}X)\} & (B_n) \\ \{\overrightarrow{\prod}_{1 \leq k \leq n} (1 + z_{k, a}X)\} (1 - z_{n, a}X z_{\bar{n}, a}X) \{\overleftarrow{\prod}_{1 \leq k \leq n} (1 + z_{\bar{k}, a}X)\} & (C_n) \\ \{\overrightarrow{\prod}_{1 \leq k \leq n} (1 + z_{k, a}X)\} (1 - z_{\bar{n}, a}X z_{n, a}X)^{-1} \{\overleftarrow{\prod}_{1 \leq k \leq n} (1 + z_{\bar{k}, a}X)\} & (D_n) \end{cases}$$

$$(2.21) \quad H_a(z, X) := \begin{cases} \overleftarrow{\prod}_{1 \leq k \leq n+1} (1 - z_{k, a}X)^{-1} & (A_n) \\ \{\overrightarrow{\prod}_{1 \leq k \leq n} (1 - z_{\bar{k}, a}X)^{-1}\} (1 + z_{0, a}X) \{\overleftarrow{\prod}_{1 \leq k \leq n} (1 - z_{k, a}X)^{-1}\} & (B_n) \\ \{\overrightarrow{\prod}_{1 \leq k \leq n} (1 - z_{\bar{k}, a}X)^{-1}\} (1 - z_{n, a}X z_{\bar{n}, a}X)^{-1} \{\overleftarrow{\prod}_{1 \leq k \leq n} (1 - z_{k, a}X)^{-1}\} & (C_n) \\ \{\overrightarrow{\prod}_{1 \leq k \leq n} (1 - z_{\bar{k}, a}X)^{-1}\} (1 - z_{\bar{n}, a}X z_{n, a}X) \{\overleftarrow{\prod}_{1 \leq k \leq n} (1 - z_{k, a}X)^{-1}\} & (D_n) \end{cases}$$

where  $\overrightarrow{\prod}_{1 \leq k \leq n} A_k = A_1 \dots A_n$  and  $\overleftarrow{\prod}_{1 \leq k \leq n} A_k = A_n \dots A_1$ . Then we have

$$(2.22) \quad H_a(z, X) E_a(z, -X) = E_a(z, -X) H_a(z, X) = 1.$$

For any  $i \in \mathbb{Z}$  and  $a \in \mathbb{C}$ , we define  $e_{i,a}, h_{i,a} \in \mathcal{Z}$  as

$$E_a(z, X) = \sum_{i=0}^{\infty} e_{i,a} X^i, \quad H_a(z, X) = \sum_{i=0}^{\infty} h_{i,a} X^i.$$

Set  $e_{i,a} = h_{i,a} = 0$  for  $i < 0$ . Note that  $e_{i,a} = 0$  if  $i > n+1$  (resp. if  $i > 2n+2$  or  $i = n+1$ ) for  $A_n$  (resp. for  $C_n$ ).

It has been observed in [14, 21] (see also [20, 22]) that  $e_{i,a}$  is the  $q$ -character of the  $i$ th fundamental representation for  $1 \leq i \leq n$  ( $i \neq n$  for  $B_n$ ,  $i \neq n-1, n$  for  $D_n$ ), while  $h_{i,a}$  is the  $q$ -character of the  $i$ th ‘‘symmetric’’ power of the first fundamental representation for any  $i \geq 1$ , though only a part of them are proven in the literature (e.g. [26]).

Due to the relation (2.22), it holds that [25]  
(2.23)

$$\det(h_{\lambda_i - \mu_j - i + j, a + 2(\lambda_i - i)\delta})_{1 \leq i, j \leq l} = \det(e_{\lambda'_i - \mu'_j - i + j, a - 2(\mu'_j - j + 1)\delta})_{1 \leq i, j \leq l'}$$

for any partitions  $(\lambda, \mu)$ , where  $l$  and  $l'$  are any non-negative integers such that  $l \geq l(\lambda), l(\mu)$  and  $l' \geq l(\lambda'), l(\mu')$ . For any skew diagram  $\lambda/\mu$ , let  $\chi_{\lambda/\mu, a}$  denote the determinant on the left or right hand side of (2.23). We call it the *Jacobi-Trudi determinant* of  $U_q(\hat{\mathfrak{g}})$  associated to  $\lambda/\mu$  and  $a \in \mathbb{C}$ . Note that  $\chi_{(i), a} = h_{i,a}$  and  $\chi_{(1^i), a} = e_{i,a}$ .

- Conjecture 2.2.** (1) *If  $\mathfrak{g}$  is of type  $A_n$  or  $B_n$  and  $\lambda/\mu$  is a skew diagram of  $d(\lambda/\mu) \leq n$ , then  $\chi_{\lambda/\mu, a} = \chi_q(V(\lambda/\mu, a))$ .*  
(2) *If  $\mathfrak{g}$  is of type  $C_n$  and  $\lambda/\mu$  is a skew diagram of  $d(\lambda/\mu) \leq n$ , then  $\chi_{\lambda/\mu, a}$  is the  $q$ -character of certain (not necessarily irreducible) representation  $V$  of  $U_q(\hat{\mathfrak{g}})$  which has  $V(\lambda/\mu, a)$  as a subquotient; furthermore, if  $\mu = \phi$ , then  $V = V(\lambda, a)$ .*  
(3) *If  $\mathfrak{g}$  is of type  $D_n$  and  $\lambda/\mu$  is a skew diagram of  $d(\lambda/\mu) \leq n$ , then  $\chi_{\lambda/\mu, a}$  is the  $q$ -character of certain (not necessarily irreducible) representation  $V$  of  $U_q(\hat{\mathfrak{g}})$  which has  $V(\lambda/\mu, a)$  as a subquotient; furthermore, if  $\mu = \phi$  and  $d(\lambda) \leq n-1$ , then  $V = V(\lambda, a)$ .*

Several remarks on Conjecture 2.2 are in order.

1. For  $C_n$ , we checked by computer that  $\chi_{\lambda, a}$  agrees with the result obtained from the conjectural algorithm of [13] to create the  $q$ -character for several  $\lambda$ .
2. It is interesting that the determinant (2.23) is simpler than the Jacobi-Trudi type formula for the characters of  $\mathfrak{g}$  for the irreducible representations  $V(\lambda)$  in [23].
3. The determinant  $\chi_{\lambda/\mu, a}$  appeared in [7] for  $A_n$  and [20] for  $B_n$  in the context of the transfer matrices.
4. An analogue of Conjecture 2.2 is true for the representations of Yangian  $Y(\mathfrak{sl}_n)$ , which can be proved [2] using the results in [3, 4].
5. Conjecture 2.2 is an affinization of the conjecture of [9] (see Remark A.2 in Appendix A).



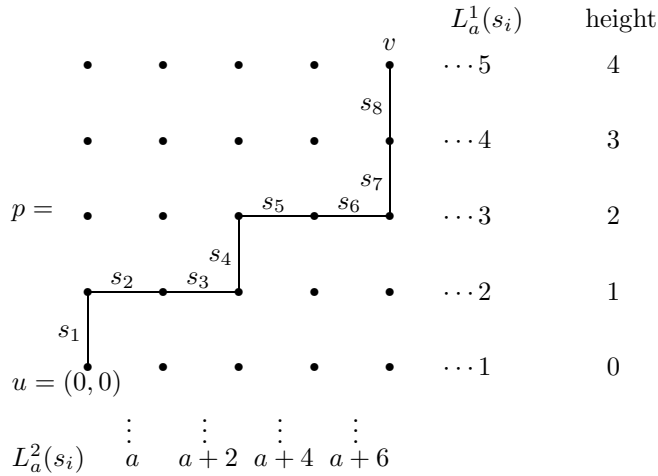

FIGURE 2. An example of a path  $p$  and its  $h$ -labeling.

6. For  $C_n$  and  $D_n$ , we further expect that  $V = V(\lambda/\mu, a)$  if  $\lambda/\mu$  is connected. But, if  $\lambda/\mu$  is not connected, there are certainly counter-examples. A counter-example for  $C_2$  is as follows: Let  $(\lambda, \mu) = ((3, 1), (2))$ . By (2.23), we have  $\chi_{\lambda/\mu, a+2} = h_{1,a}h_{1,a+6} = \chi_q(V_{\omega_1}(q^a) \otimes V_{\omega_1}(q^{a+6}))$ . On the other hand, the  $R$ -matrix  $R_{\omega_1, \omega_1}(u)$  has singularities at  $u = q^6$  (see [1] for example), which implies that  $V_{\omega_1}(q^a) \otimes V_{\omega_1}(q^{a+6})$  is not irreducible. The case  $(\lambda, \mu) = ((3, 1), (2))$  for  $D_4$  is a similar counter-example.

In the following sections, we study the explicit description of  $\chi_{\lambda/\mu, a}$  by tableaux.

### 3. TABLEAUX DESCRIPTION OF TYPE $A_n$

In this section, we consider the case that  $\mathfrak{g}$  is of type  $A_n$ . The tableaux description of  $\chi_{\lambda/\mu, a}$  (2.23) is given by [7]. We reproduce it by applying the “paths” method of [16] (see also [28]). During this section,  $I$  is of type  $A_n$  in (2.1).

**3.1. Paths description.** Consider the lattice  $\mathbb{Z} \times \mathbb{Z}$ . A *path*  $p$  in the lattice is a sequence of steps  $(s_1, s_2, \dots)$  such that each step  $s_i$  is of unit length with the northward ( $N$ ) or eastward ( $E$ ) direction. For example, see Figure 2. If  $p$  starts at point  $u$  and ends at point  $v$ , we write this by  $u \xrightarrow{p} v$ . For any path  $p$ , set  $E(p) := \{s \in p \mid s \text{ is an eastward step}\}$ .

An  *$h$ -path of type  $A_n$*  is a path  $u \xrightarrow{p} v$  such that the initial point  $u$  is at height 0 and the final point  $v$  is at height  $n$ , where the *height* of the point  $(x, y) \in \mathbb{Z} \times \mathbb{Z}$  is  $y$ . Let  $P(A_n)$  be the set of all the  $h$ -paths of type  $A_n$ . For any  $a \in \mathbb{C}$ , the  *$h$ -labeling of type  $A_n$*  associated to  $a \in \mathbb{C}$  for a path

$p \in P(A_n)$  is the pair of maps  $L_a = (L_a^1, L_a^2)$ ,

$$L_a^1 : E(p) \rightarrow I, \quad L_a^2 : E(p) \rightarrow \{a + 2k \mid k \in \mathbb{Z}\},$$

defined as follows: If  $s$  starts at the point  $(x, y)$ , then  $L_a(s) = (y + 1, a + 2x)$ . For example,  $L_a(s_3) = (2, a + 2)$  for  $s_3$  in Figure 2. Using these definitions, we define

$$(3.1) \quad z_a^p = \prod_{s \in E(p)} z_{L_a^1(s), L_a^2(s)} \in \mathcal{Z}$$

for any  $p \in P(A_n)$ , where  $\mathcal{Z}$  is the ring defined in Section 2. For example,  $z_a^p = z_{2,a} z_{2,a+2} z_{3,a+4} z_{3,a+6}$  for  $p$  in Figure 2. By (2.21), we have

$$(3.2) \quad h_{r,a+2k+2r-2}(z) = \sum_p z_a^p,$$

where the sum runs over all  $p \in P(A_n)$  such that  $(k, 0) \xrightarrow{p} (k + r, n)$ .

For any  $l$ -tuples of initial points  $\mathbf{u} = (u_1, u_2, \dots, u_l)$  and final points  $\mathbf{v} = (v_1, v_2, \dots, v_l)$ , let  $\mathfrak{P}(\pi; \mathbf{u}, \mathbf{v})$  be the set of  $l$ -tuples of paths  $\mathbf{p} = (p_1, \dots, p_l)$  such that  $u_i \xrightarrow{p_i} v_{\pi(i)}$  for any permutation  $\pi \in \mathfrak{S}_l$ . Set

$$\mathfrak{P}(\mathbf{u}, \mathbf{v}) := \sum_{\pi \in \mathfrak{S}_l} \mathfrak{P}(\pi; \mathbf{u}, \mathbf{v}).$$

Then we define

$$\mathfrak{P}(A_n; \mathbf{u}, \mathbf{v}) := \{\mathbf{p} = (p_1, \dots, p_l) \in \mathfrak{P}(\mathbf{u}, \mathbf{v}) \mid p_i \in P(A_n)\}.$$

For any skew diagram  $\lambda/\mu$ , let  $l = l(\lambda)$ , and pick  $\mathbf{u}_\mu = (u_1, \dots, u_l)$  and  $\mathbf{v}_\lambda = (v_1, \dots, v_l)$  as  $u_i = (\mu_i + 1 - i, 0)$  and  $v_i = (\lambda_i + 1 - i, n)$ . In this case, we have  $\mathfrak{P}(A_n; \mathbf{u}_\mu, \mathbf{v}_\lambda) = \mathfrak{P}(\mathbf{u}_\mu, \mathbf{v}_\lambda)$ . We define the *weight*  $z_a^{\mathbf{p}}$  and the *signature*  $(-1)^{\mathbf{p}}$  for any  $\mathbf{p} \in \mathfrak{P}(A_n; \mathbf{u}_\mu, \mathbf{v}_\lambda)$  by

$$(3.3) \quad z_a^{\mathbf{p}} = \prod_{i=1}^l z_a^{p_i} \quad \text{and} \quad (-1)^{\mathbf{p}} = \text{sgn } \pi \quad \text{if } \mathbf{p} \in \mathfrak{P}(\pi; \mathbf{u}_\mu, \mathbf{v}_\lambda).$$

Then, the determinant (2.23) can be written as

$$(3.4) \quad \chi_{\lambda/\mu, a} = \sum_{\mathbf{p} \in \mathfrak{P}(A_n; \mathbf{u}_\mu, \mathbf{v}_\lambda)} (-1)^{\mathbf{p}} z_a^{\mathbf{p}},$$

by (3.2). Applying the method of [16], we have

**Proposition 3.1.** *For any skew diagram  $\lambda/\mu$ ,*

$$(3.5) \quad \chi_{\lambda/\mu, a} = \sum_{\mathbf{p} \in P(A_n; \mu, \lambda)} z_a^{\mathbf{p}},$$

where  $P(A_n; \mu, \lambda)$  is the set of all  $\mathbf{p} = (p_1, \dots, p_l) \in \mathfrak{P}(A_n; \mathbf{u}_\mu, \mathbf{v}_\lambda)$  which do not have any intersecting pair of paths  $(p_i, p_j)$ .

*Proof.* Let  $P^c(A_n; \mu, \lambda) := \{\mathbf{p} \in \mathfrak{P}(A_n; \mathbf{u}_\mu, \mathbf{v}_\lambda) \mid \mathbf{p} \notin P(A_n; \mu, \lambda)\}$ . The idea of [16] is to consider an involution

$$\iota : P^c(A_n; \mu, \lambda) \rightarrow P^c(A_n; \mu, \lambda)$$

defined as follows: For  $\mathbf{p} = (p_1, \dots, p_l)$ , let  $(p_i, p_j)$  be the first intersecting pair of paths, i.e.,  $i$  is the minimal number such that  $p_i$  intersects with another path and  $j (\neq i)$  is the minimal number such that  $p_j$  intersects with  $p_i$ . Let  $v_0$  be the first intersecting point of  $p_i$  and  $p_j$ . If  $u_i \xrightarrow{p_i} v_{\pi(i)}$  ( $i = 1, \dots, l$ ), then  $\iota(\mathbf{p}) = (p'_1, \dots, p'_l)$  is given by  $p'_k := p_k$  ( $k \neq i, j$ ) and

$$p'_i : u_i \xrightarrow{p_i} v_0 \xrightarrow{p_j} v_{\pi(j)}, \quad p'_j : u_j \xrightarrow{p_j} v_0 \xrightarrow{p_i} v_{\pi(i)}.$$

Then  $\iota$  preserves the weights and inverts the signature, i.e.,  $z_a^{\iota(\mathbf{p})} = z_a^{\mathbf{p}}$  and  $(-1)^{\iota(\mathbf{p})} = -(-1)^{\mathbf{p}}$ . Therefore, the contributions of all  $\mathbf{p} \in P^c(A_n; \mu, \lambda)$  to the right hand side of (3.4) are canceled with each other. The signature of any  $\mathbf{p} \in P(A_n; \mu, \lambda)$  is  $(-1)^{\mathbf{p}} = 1$ , and we obtain the proposition.  $\square$

### 3.2. Tableaux description.

**Definition 3.2.** A tableau  $T$  with entries  $T(i, j) \in I$  is called an  $A_n$ -tableau if it satisfies the following conditions:

- (H) horizontal rule  $T(i, j) \leq T(i, j + 1)$ .
- (V) vertical rule  $T(i, j) < T(i + 1, j)$ .

Namely, an  $A_n$ -tableau is nothing but a semistandard tableau. We write the set of all the  $A_n$ -tableaux of shape  $\lambda/\mu$  by  $\text{Tab}(A_n, \lambda/\mu)$ .

For any  $\mathbf{p} = (p_1, \dots, p_l) \in P(A_n; \mu, \lambda)$ , we associate a tableau  $T(\mathbf{p})$  of shape  $\lambda/\mu$  such that the  $i$ th row of  $T(\mathbf{p})$  is given by  $\{L_a^1(s) \mid s \in E(p_i)\}$  listed in the increasing order. See Figure 3 for an example. Clearly,  $T(\mathbf{p})$  satisfies the horizontal rule because of the  $h$ -labeling rule of  $\mathbf{p}$ , and  $T(\mathbf{p})$  satisfies the vertical rule since  $\mathbf{p} \in P(A_n; \mu, \lambda)$  does not have any intersecting pair of paths. Therefore, we obtain a map

$$T : P(A_n; \mu, \lambda) \ni \mathbf{p} \mapsto T(\mathbf{p}) \in \text{Tab}(A_n, \lambda/\mu)$$

for any skew diagram  $\lambda/\mu$ . In fact,

**Proposition 3.3.** *The map  $T$  is a weight-preserving bijection.*

By Proposition 3.1 and 3.3, we reproduce the result of [7].

**Theorem 3.4** ([7]). *If  $\lambda/\mu$  is a skew diagram, then*

$$\chi_{\lambda/\mu, a} = \sum_{T \in \text{Tab}(A_n, \lambda/\mu)} z_a^T.$$

## 4. TABLEAUX DESCRIPTION OF TYPE $B_n$

In this section, we consider the case that  $\mathfrak{g}$  is of type  $B_n$ . The tableaux description of  $\chi_{\lambda/\mu, a}$  (2.23) is given by [20]. We reproduce it using the path method of [16]. During this section,  $I$  is of type  $B_n$  in (2.1).

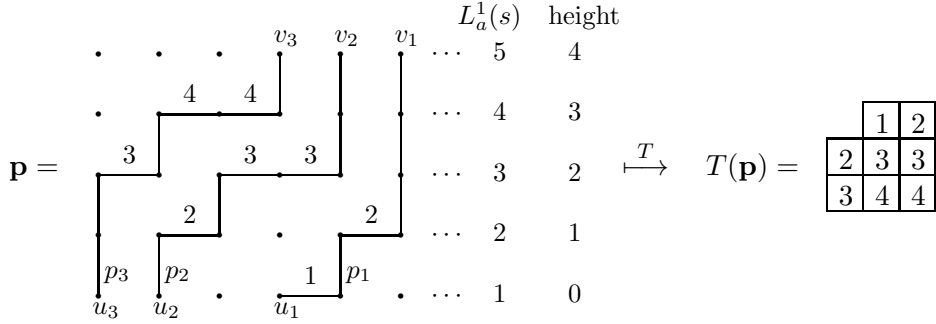

FIGURE 3. An example of  $\mathbf{p}$  and the tableau  $T(\mathbf{p})$  for  $(\lambda, \mu) = ((3^3), (1))$ .

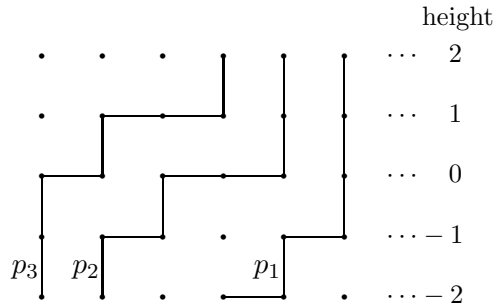

FIGURE 4. An example of  $h$ -paths of type  $B_n$  and  $C_n$ .

4.1. **Paths description.** In view of the definition of the generating function of  $H_a(z, X)$  in (2.21), we define an  $h$ -path and its  $h$ -labeling as follows:

**Definition 4.1.** Consider the lattice  $\mathbb{Z} \times \mathbb{Z}$ . An  $h$ -path of type  $B_n$  is a path  $u \xrightarrow{p} v$  such that the initial point  $u$  is at height  $-n$  and the final point  $v$  is at height  $n$ , and an eastward step at height 0 occurs at most once. We write the set of all the  $h$ -paths of type  $B_n$  by  $P(B_n)$ .

For example,  $p_1$  and  $p_3$  in Figure 4 are the  $h$ -paths of type  $B_n$ , but  $p_2$  is not.

The  $h$ -labeling of type  $B_n$  associated to  $a \in \mathbb{C}$  for any  $p \in P(B_n)$  is the pair of maps  $L_a = (L_a^1, L_a^2)$ ,

$$L_a^1 : E(p) \rightarrow I, \quad L_a^2 : E(p) \rightarrow \{a + 4k \mid k \in \mathbb{Z}\},$$

defined as follows: If  $s$  starts at  $(x, y)$  then

$$L_a^1(s) = \begin{cases} n + 1 + y, & \text{if } y < 0, \\ 0, & \text{if } y = 0, \\ \overline{n + 1 - y}, & \text{if } y > 0, \end{cases}$$

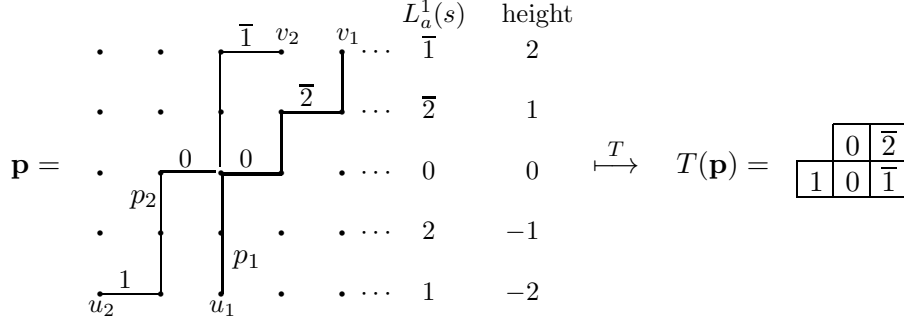

FIGURE 5. An example of  $\mathbf{p} = (p_1, p_2) \in P(B_n; \lambda, \mu)$  which is *specialy* intersecting, and their  $h$ -labelings for  $n = 2$ ,  $(\lambda, \mu) = ((3^2), (1))$ . If we set  $\iota$  as in the  $A_n$  case, then  $\iota(\mathbf{p}) \notin P(B_n; \mu, \lambda)$ , because the paths in  $\iota(\mathbf{p})$  are not the  $h$ -paths of type  $B_n$ .

and  $L_a^2(s) = a + 4x$ . Then, we define  $z_a^p$  as in (3.1). By (2.21), we have

$$(4.1) \quad h_{r, a+4k+4r-4}(z) = \sum_p z_a^p,$$

where the sum runs over all  $p \in P(B_n)$  such that  $(k, -n) \xrightarrow{p} (k+r, n)$ .

For any  $l$ -tuples of initial and final points  $\mathbf{u} = (u_1, u_2, \dots, u_l)$ ,  $\mathbf{v} = (v_1, v_2, \dots, v_l)$ , set

$$\mathfrak{P}(B_n; \mathbf{u}, \mathbf{v}) := \{\mathbf{p} = (p_1, \dots, p_l) \in \mathfrak{P}(\mathbf{u}, \mathbf{v}) \mid p_i \in P(B_n)\}.$$

Let  $\lambda/\mu$  be a skew diagram and let  $l = l(\lambda)$ . Pick  $\mathbf{u}_\mu = (u_1, \dots, u_l)$  and  $\mathbf{v}_\lambda = (v_1, \dots, v_l)$  as  $u_i = (\mu_i + 1 - i, -n)$  and  $v_i = (\lambda_i + 1 - i, n)$ . We define the weight  $z^{\mathbf{p}}$  and its signature  $(-1)^{\mathbf{p}}$  for any  $\mathbf{p} \in \mathfrak{P}(B_n; \mathbf{u}_\mu, \mathbf{v}_\lambda)$ , as in the  $A_n$  case in (3.3). Then, the determinant (2.23) can be written as

$$\chi_{\lambda/\mu, a} = \sum_{\mathbf{p} \in \mathfrak{P}(B_n; \mathbf{u}_\mu, \mathbf{v}_\lambda)} (-1)^{\mathbf{p}} z_a^{\mathbf{p}},$$

by (4.1). The difference from the  $A_n$  case is that the involution  $\iota$  is not defined on any  $\mathbf{p} = (p_1, \dots, p_l) \in \mathfrak{P}(B_n; \mathbf{u}_\mu, \mathbf{v}_\lambda)$  that possesses an intersecting pair  $(p_i, p_j)$  (see Figure 5). To define an involution for the  $B_n$  case, we give the following definition.

**Definition 4.2.** An intersecting pair  $(p, p')$  of  $h$ -paths of type  $B_n$  is called *specialy intersecting* (resp. *ordinarily intersecting*) if the intersection of  $p$  and  $p'$  occurs only at height 0 (resp. otherwise).

For example, the pair  $(p_1, p_2)$  given in Figure 5 is specialy intersecting.

Applying the method of [16] as in the  $A_n$  case, we have

**Proposition 4.3.** For any skew diagram  $\lambda/\mu$ ,

$$(4.2) \quad \chi_{\lambda/\mu, a} = \sum_{\mathbf{p} \in P(B_n; \mu, \lambda)} z_a^{\mathbf{p}},$$

where  $P(B_n; \mu, \lambda)$  is the set of all  $\mathbf{p} = (p_1, \dots, p_l) \in \mathfrak{P}(B_n; \mathbf{u}_\mu, \mathbf{v}_\lambda)$  which do not have any ordinarily intersecting pairs of paths  $(p_i, p_j)$ .

*Proof.* Let  $P^c(B_n; \mu, \lambda) := \{\mathbf{p} \in \mathfrak{P}(B_n; \mathbf{u}_\mu, \mathbf{v}_\lambda) \mid \mathbf{p} \notin P(B_n; \mu, \lambda)\}$ . Consider an involution

$$\iota : P^c(B_n; \mu, \lambda) \rightarrow P^c(B_n; \mu, \lambda)$$

defined as follows: For  $\mathbf{p} = (p_1, \dots, p_l)$ , there exists  $(p_i, p_j)$  which is ordinarily intersecting. Let  $(p_i, p_j)$  be the first such pair and let  $v_0$  be the first intersecting point whose height is not 0. Then set  $\iota(\mathbf{p})$  as in the proof of Proposition 3.1. Then  $\iota$  is weight-preserving and sign-inverting, which implies that all  $\mathbf{p} \in P^c(B_n; \mu, \lambda)$  will be canceled as in the  $A_n$  case. The signature of any  $\mathbf{p} \in P(B_n; \mu, \lambda)$  is  $(-1)^{\mathbf{P}} = 1$ , and we obtain the proposition.  $\square$

**4.2. Tableaux description.** Define a total ordering in  $I$  (2.1) by

$$1 \prec 2 \prec \dots \prec n \prec 0 \prec \bar{n} \prec \dots \prec \bar{2} \prec \bar{1}.$$

**Definition 4.4** ([20]). A tableau  $T$  with entries  $T(i, j) \in I$  is called a  $B_n$ -tableau if it satisfies the following conditions:

(H)  $T(i, j) \preceq T(i, j+1)$  and  $(T(i, j), T(i, j+1)) \neq (0, 0)$ .

(V)  $T(i, j) \prec T(i+1, j)$  or  $(T(i, j), T(i+1, j)) = (0, 0)$ .

We write the set of all the  $B_n$ -tableaux of shape  $\lambda/\mu$  by  $\text{Tab}(B_n, \lambda/\mu)$ .

For any  $\mathbf{p} \in P(B_n; \mu, \lambda)$ , let  $T(\mathbf{p})$  be the tableau of shape  $\lambda/\mu$  defined by assigning the  $h$ -labeling of each path in  $\mathbf{p}$  to the corresponding rows, as in the  $A_n$  case (see Figure 5). Then  $T(\mathbf{p})$  satisfies the rule (H) in Definition 4.4 because of the rule for the  $h$ -labeling of  $\mathbf{p}$ , and it satisfies the rule (V) since  $\mathbf{p}$  does not have any ordinarily intersecting pairs of paths. Therefore, we obtain a map

$$T : P(B_n; \mu, \lambda) \ni \mathbf{p} \longmapsto T(\mathbf{p}) \in \text{Tab}(B_n, \lambda/\mu)$$

for any skew diagram  $\lambda/\mu$ . In fact,

**Proposition 4.5.** *The map  $T$  is a weight-preserving bijection.*

Thus, we obtain

**Theorem 4.6** ([20]). *If  $\lambda/\mu$  is a skew diagram, then*

$$\chi_{\lambda/\mu, a} = \sum_{T \in \text{Tab}(B_n, \lambda/\mu)} z_a^T.$$

## 5. TABLEAUX DESCRIPTION OF TYPE $C_n$

In this section, we consider the case that  $\mathfrak{g}$  is of type  $C_n$ . We determine the tableaux description by the horizontal, vertical and ‘‘extra’’ rules for skew diagrams of at most three rows and of at most two columns. The one-row and one-column cases are already given by [22].

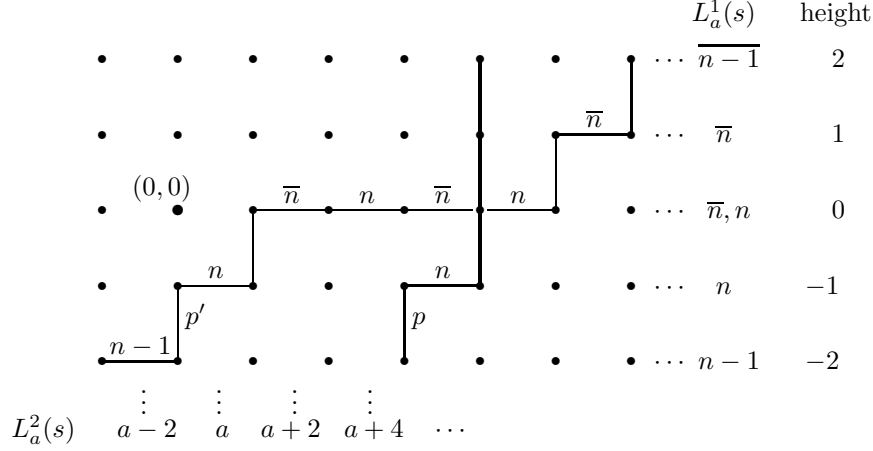

FIGURE 6. An example of  $h$ -paths of type  $C_n$  and their  $h$ -labelings.

**5.1. Paths description.** In view of the definition of the generating function of  $H_a(z, X)$  in (2.21), we define an  $h$ -path and its  $h$ -labeling as follows:

**Definition 5.1.** Consider the lattice  $\mathbb{Z} \times \mathbb{Z}$ . An  $h$ -path of type  $C_n$  is a path  $u \xrightarrow{p} v$  such that the initial point  $u$  is at height  $-n$  and the final point  $v$  is at height  $n$ , and the number of the eastward steps at height 0 is even. We write the set of all the  $h$ -paths of type  $C_n$  by  $P(C_n)$ .

For example,  $p_1$  and  $p_2$  in Figure 4 are the  $h$ -paths of type  $C_n$ , but  $p_3$  is not.

For a path  $p = (s_1, s_2, \dots) \in P(C_n)$ , let  $E_0(p) = (s_j, s_{j+1}, \dots)$  be the sequence of all the eastward steps at height 0 in  $p$ . Let  $E_0^1(p)$  and  $E_0^2(p)$  be the subsequence of  $E_0(p)$  defined by  $E_0^1(p) = (s_j, s_{j+2}, s_{j+4}, \dots)$  and  $E_0^2(p) = (s_{j+1}, s_{j+3}, s_{j+5}, \dots)$ . The  $h$ -labeling of type  $C_n$  associated to  $a \in \mathbb{C}$  for any  $p \in P(C_n)$  is a pair of maps  $L_a = (L_a^1, L_a^2)$ ,

$$(5.1) \quad L_a^1 : E(p) \rightarrow I, \quad L_a^2 : E(p) \rightarrow \{a + 2k \mid k \in \mathbb{Z}\},$$

defined as follows: If  $s$  starts at  $(x, y)$ , then

$$L_a^1(s) = \begin{cases} n + 1 + y, & \text{if } y < 0, \\ n + 1 - y, & \text{if } y > 0, \\ \bar{n}, & \text{if } s \in E_0^1(p), \\ n, & \text{if } s \in E_0^2(p), \end{cases}$$

and  $L_a^2(s) = a + 2x$ . See Figure 6 for an example.

Define  $z_a^p$  as in (3.1). By (2.21), we have

$$(5.2) \quad h_{r, a+2k+2r-2}(z) = \sum_p z_a^p,$$

where the sum runs over all  $p \in P(C_n)$  such that  $(k, -n) \xrightarrow{p} (k+r, n)$ .

For any  $l$ -tuples of initial and final points  $\mathbf{u} = (u_1, u_2, \dots, u_l)$ ,  $\mathbf{v} = (v_1, v_2, \dots, v_l)$ , set

$$\mathfrak{P}(C_n; \mathbf{u}, \mathbf{v}) := \{\mathbf{p} = (p_1, \dots, p_l) \in \mathfrak{P}(\mathbf{u}, \mathbf{v}) \mid p_i \in P(C_n)\}.$$

Let  $\lambda/\mu$  be a skew diagram and let  $l = l(\lambda)$ . Pick  $\mathbf{u}_\mu = (u_1, \dots, u_l)$  and  $\mathbf{v}_\lambda = (v_1, \dots, v_l)$  as  $u_i = (\mu_i + 1 - i, -n)$  and  $v_i = (\lambda_i + 1 - i, n)$ . We define the weight  $z^{\mathbf{p}}$  and the signature  $(-1)^{\mathbf{p}}$  for any  $\mathbf{p} \in \mathfrak{P}(C_n; \mathbf{u}, \mathbf{v})$  by the  $h$ -labeling of type  $C_n$  as in (3.3). Then, the determinant (2.23) can be written as

$$\chi_{\lambda/\mu, a} = \sum_{\mathbf{p} \in \mathfrak{P}(C_n; \mathbf{u}_\mu, \mathbf{v}_\lambda)} (-1)^{\mathbf{p}} z_a^{\mathbf{p}},$$

by (5.2).

As in the  $B_n$  case, the involution  $\iota$  is not defined on any  $\mathbf{p} = (p_1, \dots, p_l) \in \mathfrak{P}(C_n; \mathbf{u}_\mu, \mathbf{v}_\lambda)$  which possesses an intersecting pair of paths  $(p_i, p_j)$ . To define the involution for the  $C_n$  case, we give the definition of the specially (resp. ordinarily) intersecting pair of paths.

Consider two paths  $p, p'$  which is intersecting at height 0. Let  $(x, 0)$  (resp.  $(x', 0)$ ) be the leftmost point on  $p$  (resp.  $p'$ ) at height 0. Then set  $[p, p'] := |x - x'|$ .

**Definition 5.2.** An intersecting pair  $(p, p')$  of  $h$ -paths of type  $C_n$  is called *specially intersecting* (resp. *ordinarily intersecting*) if the intersection of  $p$  and  $p'$  occurs only at height 0 and  $[p, p']$  is odd (resp. otherwise).

For example,  $[p, p'] = 3$  for  $(p, p')$  in Figure 6, and therefore, it is specially intersecting.

Applying the method of [16], we have

**Proposition 5.3.** For any skew diagram  $\lambda/\mu$ ,

$$(5.3) \quad \chi_{\lambda/\mu, a} = \sum_{\mathbf{p} \in P(C_n; \mu, \lambda)} (-1)^{\mathbf{p}} z_a^{\mathbf{p}},$$

where  $P(C_n; \mu, \lambda)$  is the set of all  $\mathbf{p} = (p_1, \dots, p_l) \in \mathfrak{P}(C_n; \mathbf{u}_\mu, \mathbf{v}_\lambda)$  which do not have any ordinarily intersecting pair of paths  $(p_i, p_j)$ .

*Proof.* Let  $P^c(C_n; \mu, \lambda) := \{\mathbf{p} \in \mathfrak{P}(C_n; \mathbf{u}_\mu, \mathbf{v}_\lambda) \mid \mathbf{p} \notin P(C_n; \mu, \lambda)\}$ . Consider a weight-preserving involution

$$\iota : P^c(C_n; \mu, \lambda) \rightarrow P^c(C_n; \mu, \lambda)$$

defined as follows: For  $\mathbf{p} = (p_1, \dots, p_l)$ , let  $(p_i, p_j)$  be the first ordinarily intersecting pair of paths and let  $v_0$  be the first intersecting point. Set  $\iota(\mathbf{p})$  as in the  $A_n$  case (Proposition 3.1). Then  $\iota$  is weight-preserving and sign-inverting, as in the  $A_n$  and  $B_n$  cases.  $\square$

Consider any two  $h$ -paths of type  $C_n$ ,  $(x_0, y_0) \xrightarrow{p} (x_1, y_1)$ ,  $(x'_0, y'_0) \xrightarrow{p'} (x'_1, y'_1)$ , which are not ordinarily intersecting. We say that  $(p, p')$  is *transposed* if  $(x_0 - x'_0)(x_1 - x'_1) < 0$ . For example, the pair  $(p, p')$  in Figure 6 is transposed.



Let  $P_k(C_n; \mu, \lambda)$  be the set of all  $\mathbf{p} \in P(C_n; \mu, \lambda)$  which possess exactly  $k$  transposed pairs of paths. Then we have  $(-1)^{\mathbf{p}} = (-1)^k$ . Note that if  $\mathbf{p} = (p_1, \dots, p_l) \in P(C_n; \mu, \lambda)$ , then each triplet  $(p_i, p_j, p_k)$  is not intersecting simultaneously at one point. Therefore,  $P(C_n; \mu, \lambda) = \sum_{k=0}^{l-1} P_k(C_n; \mu, \lambda)$  and the sum (5.3) is rewritten as

$$(5.4) \quad \chi_{\lambda/\mu, a} = \sum_{k=0}^{l-1} (-1)^k \sum_{\mathbf{p} \in P_k(C_n; \mu, \lambda)} z_a^{\mathbf{p}}.$$

The right hand side of (5.4) is not as simple as that of (3.5) for  $A_n$  and that of (4.2) for  $B_n$ . This is the main reason why the description of  $C_n$  becomes more complicated than that of  $A_n$  and  $B_n$ . (The  $D_n$  case which is not dealt with in this paper is similar to the  $C_n$  case.)

**5.2. Tableaux description.** To formulate the tableaux description of (5.4) we introduce a certain set of tableaux (called *HV-tableaux*)  $\widetilde{\text{Tab}}(C_n, \lambda/\mu)$  and the corresponding set of paths  $\tilde{P}(C_n; \mu, \lambda)$ .

Define a total ordering in  $I$  (2.1) by

$$1 \prec 2 \prec \dots \prec n \prec \bar{n} \prec \dots \prec \bar{2} \prec \bar{1}.$$

**Definition 5.4.** A tableau  $T$  (of shape  $\lambda/\mu$ ) with entries  $T(i, j) \in I$  is called an *HV-tableau* if it satisfies the following conditions:

(**H**) Each  $(i, j) \in \lambda/\mu$  satisfies both of the following conditions:

- $T(i, j) \preceq T(i, j+1)$  or  $(T(i, j), T(i, j+1)) = (\bar{n}, n)$ .
- $(T(i, j-1), T(i, j), T(i, j+1)) \neq (\bar{n}, \bar{n}, n), (\bar{n}, n, n)$ .

(**V**) Each  $(i, j) \in \lambda/\mu$  satisfies at least one of the following conditions:

- $T(i, j) \prec T(i+1, j)$ .
- $T(i, j) = T(i+1, j) = n$ ,  $(i+1, j-1) \in \lambda/\mu$  and  $T(i+1, j-1) = \bar{n}$ .
- $T(i, j) = T(i+1, j) = \bar{n}$ ,  $(i, j+1) \in \lambda/\mu$  and  $T(i, j+1) = n$ .

We write the set of the all the *HV-tableaux* of shape  $\lambda/\mu$  by  $\widetilde{\text{Tab}}(C_n, \lambda/\mu)$ .

Let  $\tilde{P}(C_n; \mu, \lambda)$  be the set of all  $\mathbf{p} = (p_1, \dots, p_l) \in \mathfrak{P}(C_n; \mathbf{u}_\mu, \mathbf{v}_\lambda)$  which do not have any *adjacent* pair  $(p_i, p_{i+1})$  which is either ordinarily intersecting or transposed. We remark that  $P_k(C_n; \mu, \lambda) \cap \tilde{P}(C_n; \mu, \lambda) = \emptyset$  ( $k \geq 1$ ) and

$$\begin{aligned} P_0(C_n; \mu, \lambda) &= \tilde{P}(C_n; \mu, \lambda) \quad \text{if } l(\lambda) \leq 2, \\ P_0(C_n; \mu, \lambda) &\subsetneq \tilde{P}(C_n; \mu, \lambda) \quad \text{if } l(\lambda) \geq 3. \end{aligned}$$

For any  $\mathbf{p} \in \tilde{P}(C_n; \mu, \lambda)$ , let  $T(\mathbf{p})$  be the tableau of shape  $\lambda/\mu$  defined by assigning the  $h$ -labeling of each path in  $\mathbf{p}$  to the corresponding row, as in the  $A_n$  and  $B_n$  cases (see Figure 7). Then  $T(\mathbf{p})$  is an *HV-tableau*; it satisfies the rule (**H**) in Definition 5.4 because of the rule for the  $h$ -labeling of  $\mathbf{p}$ , and it satisfies the rule (**V**) since  $\mathbf{p}$  does not have any adjacent pairs of paths which is either ordinarily intersecting or transposed. Therefore, we obtain a map

$$T : \tilde{P}(C_n; \mu, \lambda) \ni \mathbf{p} \mapsto T(\mathbf{p}) \in \widetilde{\text{Tab}}(C_n, \lambda/\mu)$$

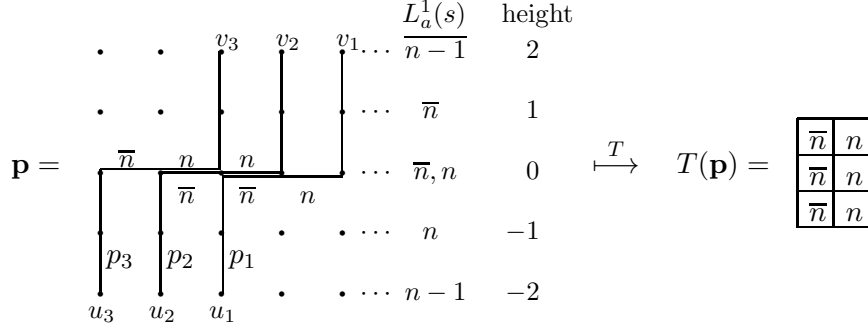

FIGURE 7. An example of  $\mathbf{p} \in \tilde{P}(C_n; \mu, \lambda)$  for  $(\lambda, \mu) = ((2^3), \phi)$  and its  $h$ -labeling. The pair  $(p_1, p_3)$  is ordinarily intersecting, and therefore,  $\mathbf{p} \notin P(C_n; \mu, \lambda)$ .

for any skew diagram  $\lambda/\mu$  as similar as the previous cases. Moreover,

**Proposition 5.5.** *The map  $T$  is a weight-preserving bijection.*

We expect that the alternative sum (5.4) can be translated into the following positive sum by tableaux,

$$(5.5) \quad \chi_{\lambda/\mu, a} = \sum_{T \in \text{Tab}(C_n, \lambda/\mu)} z_a^T,$$

where  $\text{Tab}(C_n, \lambda/\mu)$  is a certain subset of  $\widetilde{\text{Tab}}(C_n, \lambda/\mu)$ . Thus, the tableaux in  $\text{Tab}(C_n, \lambda/\mu)$  are described by the horizontal rules (**H**) and the vertical rules (**V**) in Definition 5.4, and the *extra* rules which select them out of  $\widetilde{\text{Tab}}(C_n, \lambda/\mu)$ .

In the following subsections, we show how the tableaux description (5.5) is naturally obtained from (5.4) for the skew diagrams  $\lambda/\mu$  of at most three rows and of at most two columns.

Roughly speaking, the idea is as follows (see (5.10) and (5.20)): We introduce the weight-preserving maps  $f_k$  which “resolve” the intersection of a transposed pair of  $\mathbf{p} \in P_k(C_n; \mu, \lambda)$  in (5.4), and show that the contributions for (5.4) from  $P_k(C_n; \mu, \lambda)$  ( $k \geq 1$ ) almost cancel with each other. Then, the remaining positive contributions fill the difference  $\tilde{P}(C_n; \mu, \lambda) \setminus P_0(C_n; \mu, \lambda)$ , while the remaining negative contributions turn into the extra rules. We remark that the relation (2.4) plays a crucial role in the weight-preserving property of the maps  $f_k$ .

**5.3. Skew diagrams of at most three rows.** In this subsection, we consider the tableaux description for skew diagrams of at most three rows.

*The case of one-row.* Let  $\lambda/\mu$  be a one-row diagram, i.e.,  $l(\lambda) = 1$ . Then there does not exist any  $\mathbf{p} \in P(C_n; \mu, \lambda)$  which possesses a transposed pair of paths, and therefore,  $P(C_n; \mu, \lambda) = P_0(C_n; \mu, \lambda) = \tilde{P}(C_n; \mu, \lambda)$ . Thus,  $\text{Tab}(C_n, \lambda/\mu)$  in the equality (5.5) is exactly the set  $\widetilde{\text{Tab}}(C_n, \lambda/\mu)$ .

*The case of two-row.* Let  $\lambda/\mu$  be a skew diagram of two rows, i.e.,  $l(\lambda) = 2$ . Let  $\text{Tab}(C_n, \lambda/\mu)$  be the set of all the  $HV$ -tableaux  $T$  with the following extra condition:

**(E-2R)** If  $T$  contains a subtableau (excluding  $a$  and  $b$ )

$$(5.6) \quad \begin{array}{c} \overbrace{\begin{array}{|c|c|c|c|} \hline n & n & \cdots & n \\ \hline \bar{n} & \bar{n} & \cdots & \bar{n} \\ \hline \end{array}}^k a \\ b \end{array}$$

where  $k$  is an odd number, then at least one of the following conditions holds:

- (1) Let  $(i_1, j_1)$  be the position of the top-right corner of the subtableau (5.6). Then  $(i_1, j_1 + 1) \in \lambda/\mu$  and  $a := T(i_1, j_1 + 1) = n$ .
- (2) Let  $(i_2, j_2)$  be the position of the bottom-left corner of the subtableau (5.6). Then  $(i_2, j_2 - 1) \in \lambda/\mu$  and  $b := T(i_2, j_2 - 1) = \bar{n}$ .

Then

**Theorem 5.6.** *For any skew diagram  $\lambda/\mu$  with  $l(\lambda) = 2$ , the equality (5.5) holds.*

*Proof.* For  $\lambda/\mu$  is a skew diagram of  $l(\lambda) = 2$ , there does not exist any  $\mathbf{p} \in P(C_n; \mu, \lambda)$  that possesses more than one transposed pair of paths, we have  $P(C_n; \mu, \lambda) = P_0(C_n; \mu, \lambda) \sqcup P_1(C_n; \mu, \lambda)$ . We also have  $\tilde{P}(C_n; \mu, \lambda) = P_0(C_n; \mu, \lambda)$ . Define  $f_1 : P_1(C_n; \mu, \lambda) \rightarrow P_0(C_n; \mu, \lambda)$  by  $f_1 = r_0$ , where  $r_0$  is a weight-preserving injection defined as in Appendix B. See also Figure 11. Roughly speaking,  $r_0$  is a map which resolves the intersection of specially intersecting paths. From (5.4) and Proposition 5.5, we have

$$\chi_{\lambda/\mu, a} = \sum_{T \in \widetilde{\text{Tab}}(C_n, \lambda/\mu)} z_a^T - \sum_{\mathbf{p} \in \text{Im } f_1} z_a^{T(\mathbf{p})}.$$

The set  $\{T(\mathbf{p}) \mid \mathbf{p} \in \text{Im } f_1\}$  consists of all the tableaux in  $\widetilde{\text{Tab}}(C_n, \lambda/\mu)$  prohibited by the extra rule **(E-2R)**.  $\square$

*The case of three-row.* Let  $\lambda/\mu$  be a skew diagram of three rows, i.e.,  $l(\lambda) = 3$ . Let  $\text{Tab}(C_n, \lambda/\mu)$  be all the  $HV$ -tableaux  $T$  which satisfy **(E-2R)** and the following conditions:

**(E-3R)**

- (1) If  $T$  contains a subtableau (excluding  $a$  and  $b$ )

$$(5.7) \quad \begin{array}{c} \overbrace{\begin{array}{|c|c|c|c|c|c|c|c|c|c|} \hline \overbrace{n \cdots}^{k_1} \overbrace{n-1 \cdots}^{k_2} \overbrace{\bar{n} \cdots}^{2k_3} \overbrace{\bar{n} \cdots}^{k_4} \overbrace{n \cdots}^{k_5} \\ \hline n \cdots \cdots n \bar{n} \cdots \bar{n} \cdots \bar{n} \cdots n \bar{n} \cdots \bar{n} \cdots n \\ \hline \bar{n} \cdots \bar{n} \bar{n} \cdots \bar{n} \cdots \bar{n} \cdots \bar{n} \cdots \bar{n} \cdots \bar{n} \cdots \bar{n} \cdots \bar{n} \cdots \bar{n} \\ \hline \end{array}}^a \\ b \end{array}$$

where  $k_i \in \mathbb{Z}_{\geq 0}$  and  $k_1 + k_2 + k_4 + k_5$  is an odd number with  $k_2 \neq 0$  or  $k_4 \neq 0$ , then at least one of the following conditions holds.

- (a) Let  $(i_1, j_1)$  be the position of the top-right corner of the subtableau (5.7). Then  $(i_1, j_1 + 1) \in \lambda/\mu$  and  $a := T(i_1, j_1 + 1) \prec T(i_1 + 1, j_1)$ .
- (b) Let  $(i_2, j_2)$  be the position of the bottom-left corner of the subtableau (5.7). Then  $(i_2, j_2 - 1) \in \lambda/\mu$  and  $b := T(i_2, j_2 - 1) \succ T(i_2 - 1, j_2)$ .
- (2) If  $T$  contains the subtableau (excluding  $a$ )

$$(5.8) \quad \begin{array}{|c|c|c|c|c|} \hline & \overbrace{2} & \overbrace{2k_3} & \overbrace{k_4} & \overbrace{k_5} \\ \hline & n-1 & \cdots & \cdots n-1 & n \cdots n \\ \hline \bar{n} & n & \bar{n} & n \cdots \bar{n} & n \\ \hline \bar{n} & n-1 & \cdots & \cdots & \bar{n}-1 \\ \hline \end{array} \quad a$$

where  $k_i \in \mathbb{Z}_{\geq 0}$  and  $k_4 + k_5$  is an odd number with  $k_4 \neq 0$ , then the following holds: Let  $(i, j)$  be the position of the top-right corner of the subtableau (5.8). Then  $(i, j + 1) \in \lambda/\mu$  and  $a := T(i, j + 1) \prec T(i + 1, j)$ .

- (3) If  $T$  contains the subtableau (excluding  $b$ )

$$(5.9) \quad \begin{array}{|c|c|c|c|c|} \hline & \overbrace{k_1} & \overbrace{k_2} & \overbrace{2k_3} & \overbrace{2} \\ \hline & n-1 & \cdots & \cdots & n-1 & n \\ \hline n & \cdots & \cdots & n & \bar{n} & n \cdots \bar{n} & n \\ \hline \bar{n} & \cdots & \bar{n} & n-1 & \cdots & \cdots & \bar{n}-1 \\ \hline \end{array} \quad b$$

where  $k_i \in \mathbb{Z}_{\geq 0}$  and  $k_1 + k_2$  is an odd number with  $k_2 \neq 0$ , then the following holds: Let  $(i, j)$  be the position of the bottom-left corner of the subtableau (5.9). Then  $(i, j - 1) \in T$  and  $b := T(i, j - 1) \succ T(i - 1, j)$ .

Then

**Theorem 5.7.** *For any skew diagram  $\lambda/\mu$  of  $l(\lambda) = 3$ , the equality (5.5) holds.*

*Proof.* In this proof, we use some maps which are defined in detail in Appendix B. For a summary of this proof, see the maps and their relations in the following diagram:

$$(5.10) \quad \begin{array}{ccc} P_2^\times & \sqcup & P_2^\circ = P_2 \\ & \swarrow f_2^{23} & \searrow f_2^{13} \\ & P_1^{12} & \sqcup & P_1^{23} = P_1 \\ & \swarrow f_1^{12} & \searrow f_1^{23} \\ \text{Im } g & \sqcup & P_0 = \tilde{P} \end{array}$$

Here,  $P_2^\times$  denotes  $P_2(C_n; \mu, \lambda)^\times$ , for instance.

For  $\lambda/\mu$  is a skew diagram of  $l(\lambda) = 3$ , there does not exist any  $\mathbf{p} \in P(C_n; \mu, \lambda)$  which possesses more than two transposed pair of paths. Therefore, we have  $P(C_n; \mu, \lambda) = P_0(C_n; \mu, \lambda) \sqcup P_1(C_n; \mu, \lambda) \sqcup P_2(C_n; \mu, \lambda)$ . Let

$P_2(C_n; \mu, \lambda)^\times$  be the subset of  $P_2(C_n; \mu, \lambda)$  (see Figure 12) which consists of all  $\mathbf{p} \in P_2(C_n; \mu, \lambda)$  such that the point  $u' := u + (-1, 1)$  and  $v' := v + (1, -1)$  are on  $\mathbf{p} = (p_1, p_2, p_3)$ , where  $u$  (resp.  $v$ ) is the leftmost intersecting point of  $(p_1, p_3)$  (resp. the rightmost intersecting point of  $(p_2, p_3)$ ). Let  $P_1^{ij}(C_n; \mu, \lambda)$  ( $1 \leq i < j \leq 3$ ) be the set of all  $\mathbf{p} = (p_1, p_2, p_3) \in P_1(C_n; \mu, \lambda)$  such that  $(p_i, p_j)$  is transposed. Let  $P_2(C_n; \mu, \lambda)^\circ := P_2(C_n; \mu, \lambda) \setminus P_2(C_n; \mu, \lambda)^\times$ . Let

$$\begin{aligned} f_2^{ij} : P_2(C_n; \mu, \lambda)^\circ &\rightarrow P_1(C_n; \mu, \lambda), & (i, j) &= (1, 3), (2, 3), \\ f_1^{ij} : P_1^{ij}(C_n; \mu, \lambda) &\rightarrow P_0(C_n; \mu, \lambda), & (i, j) &= (1, 2), (2, 3) \end{aligned}$$

be the maps that resolve the transposed pair  $(p_i, p_j)$  in  $\mathbf{p} = (p_1, p_2, p_3) \in P_k(C_n; \mu, \lambda)$ , which are defined in Appendix B.2 (see also (5.10)). These maps are weight-preserving injections (Lemmas B.4 and B.5). We remark that the set  $P_2(C_n; \mu, \lambda)^\circ$  consists of all  $\mathbf{p}$  in  $P_2(C_n; \mu, \lambda)$  such that  $f_2^{13}$  or  $f_2^{23}$  is well-defined (in fact, both of them are well-defined), while  $P_2(C_n; \mu, \lambda)^\times$  consists of all  $\mathbf{p} \in P_2(C_n; \mu, \lambda)$  such that both  $f_2^{13}$  and  $f_2^{23}$  are not well-defined.

By Lemma B.6, we have  $\text{Im } f_1^{12} \cap \text{Im } f_1^{23} = \text{Im } (f_1^{23} \circ f_2^{13}) = \text{Im } (f_1^{12} \circ f_2^{23})$ , and therefore,

$$(5.11) \quad - \sum_{\mathbf{p} \in P_1(C_n; \mu, \lambda)} z_a^{\mathbf{p}} + \sum_{\mathbf{p} \in P_2(C_n; \mu, \lambda)^\circ} z_a^{\mathbf{p}} = - \sum_{\mathbf{p} \in \text{Im } f_1^{12} \cup \text{Im } f_1^{23}} z_a^{\mathbf{p}}.$$

Let  $g : P_2(C_n; \mu, \lambda)^\times \rightarrow \tilde{P}(C_n; \mu, \lambda)$  be the weight-preserving injection defined in Section B.2 (see also Figure 12). By Lemma B.3 (1), we have

$$(5.12) \quad \sum_{\mathbf{p} \in P_0(C_n; \mu, \lambda) \sqcup P_2(C_n; \mu, \lambda)^\times} z_a^{\mathbf{p}} = \sum_{\mathbf{p} \in \tilde{P}(C_n; \mu, \lambda)} z_a^{\mathbf{p}}.$$

Combining (5.11) and (5.12), we obtain

$$\begin{aligned} \chi_{\lambda/\mu, a} &= \sum_{\mathbf{p} \in \tilde{P}(C_n; \mu, \lambda)} z_a^{\mathbf{p}} - \sum_{\mathbf{p} \in \text{Im } f_1^{12} \cup \text{Im } f_1^{23}} z_a^{\mathbf{p}} \\ &= \sum_{T \in \widetilde{\text{Tab}}(C_n, \lambda/\mu)} z_a^T - \sum_{\mathbf{p} \in \text{Im } f_1^{12} \cup \text{Im } f_1^{23}} z_a^{T(\mathbf{p})}. \end{aligned}$$

By Lemma B.7, the set  $\{T(\mathbf{p}) \mid \mathbf{p} \in \text{Im } f_1^{12} \cup \text{Im } f_1^{23}\}$  consists of all the tableaux in  $\widetilde{\text{Tab}}(C_n, \lambda/\mu)$  prohibited by the extra rules **(E-2R)** and **(E-3R)**.  $\square$

**5.4. Skew diagrams of at most two columns.** In this subsection, we conjecture the tableaux description for skew diagrams  $\lambda/\mu$  of at most two columns, and prove it for  $l(\lambda) \leq 4$ . We assume that  $l(\lambda) \leq n + 1$ .

*The case of one-column.* Let  $\lambda/\mu$  be a skew diagram of one column (i.e.,  $l(\lambda) = 1$ ). Let  $\text{Tab}(C_n, \lambda/\mu)$  be the set of all the *HV*-tableaux  $T$  (actually, the horizontal rule **(H)** is not required) with the following condition:

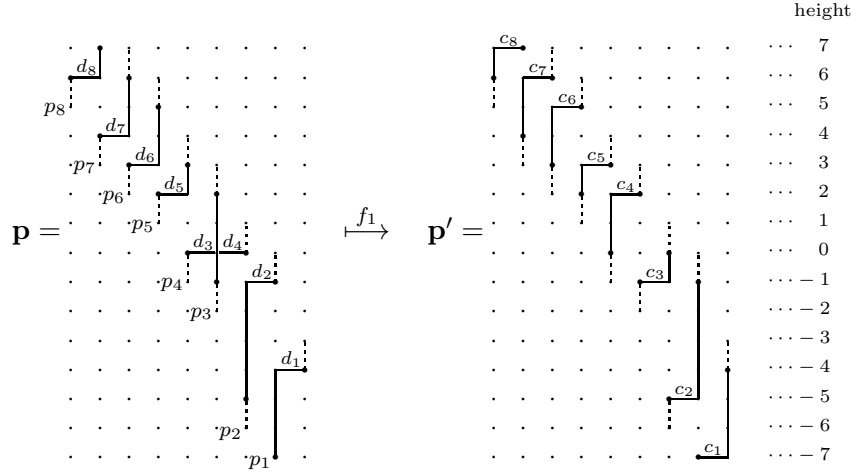

FIGURE 8. An Example of  $\mathbf{p} \in P_1(C_n; \mu, \lambda)$  for one-column  $\lambda/\mu$ . For this  $\mathbf{p}$ , the map  $f_1$  in (5.14) is given by  $f_1 = r_6^{18} \circ r_5^{17} \circ r_4^{16} \circ r_4^{27} \circ r_3^{26} \circ r_2^{25} \circ r_1^{24} \circ r_0^{34}$ . The tableau  $T(\mathbf{p}')$  does not satisfy **(E-1C)**.

**(E-1C)** If  $T$  contains a subtableau

$$(5.13) \quad \begin{array}{|c|} \hline c_1 \\ \hline \vdots \\ \hline c_l \\ \hline \end{array}$$

such that  $l \geq 2$ ,  $c_1 = c$  and  $c_l = \bar{c}$  for some  $1 \leq c \leq n$ , then  $l - 1 \leq n - c$ .

The following theorem is due to [22]. We reproduce it using the paths description.

**Theorem 5.8** ([22]). *For any skew diagram  $\lambda/\mu$  of  $l(\lambda') = 1$  and  $l(\lambda) \leq n + 1$ , the equality (5.5) holds.*

*Proof.* By  $l(\lambda') = 1$ , there does not exist any  $\mathbf{p} \in P(C_n; \mu, \lambda)$  which contains more than one transposing pair of paths, and therefore, we have  $P(C_n; \mu, \lambda) = P_0(C_n; \mu, \lambda) \sqcup P_1(C_n; \mu, \lambda)$ . We can define a weight-preserving, sign-inverting injection (which is well-defined if  $l(\lambda) \leq n + 1$ )

$$(5.14) \quad f_1 : P_1(C_n; \mu, \lambda) \rightarrow P_0(C_n; \mu, \lambda),$$

using the maps  $r_y^{ij}$  in Appendix B.1 (see also Figure 8), and show that the set  $\{T(\mathbf{p}) \mid \mathbf{p} \in \text{Im } f_1\}$  consists of all the tableaux in  $\widetilde{\text{Tab}}(C_n, \lambda/\mu)$  prohibited by the **(E-1C)** rule.  $\square$

*The case of two-column.* Let  $\lambda/\mu$  be a skew diagram of two columns, i.e.,  $l(\lambda') = 2$ . Let  $T \in \widetilde{\text{Tab}}(C_n, \lambda/\mu)$  be a tableau that contains a subtableau

$$(5.15) \quad T' = \begin{array}{|c|} \hline c_1 \\ \hline \vdots \\ \hline c_l \\ \hline \end{array} \subset T$$

such that  $l \geq 2$ ,  $c_1 = n + 2 - l$ ,  $c_l = \overline{n + 2 - l}$  and every proper subtableau of  $T'$  satisfies **(E-1C)**. Let  $\tilde{\lambda}/\tilde{\mu}$  be the one-column shape of  $T'$ . Then we can pick  $\mathbf{p} \in P_0(C_n; \tilde{\mu}, \tilde{\lambda})$  such that  $T(\mathbf{p}) = T'$ . For  $T'$  does not satisfy the extra rule **(E-1C)**, we have  $\mathbf{p} \in \text{Im } f_1$ , where  $f_1$  is the injection (5.14) in the proof of Theorem 5.8. Let  $f_1^{-1}(\mathbf{p}) = (p_1, \dots, p_l) \in P_1(C_n; \tilde{\mu}, \tilde{\lambda})$  be the inverse image of  $\mathbf{p}$ . Then set (see Figure 8)

$$(5.16) \quad d_i = d_i(T') := \begin{cases} L_a^1(s^i), & i = 1, \dots, l, \quad i \neq k, k+1, \\ \bar{n}, & i = k, \\ n, & i = k+1, \end{cases}$$

where  $L_a^1(s^i)$  is the  $h$ -label (defined in (5.1)) of the unique eastward step  $s^i$  in  $p_i$ , and  $k$  is the number such that  $c_k \preceq n$  and  $c_{k+1} \succeq \bar{n}$ . Then, one can show that

$$(5.17) \quad \{c_1, \dots, c_k\} \cup \{\bar{d}_{k+2}, \dots, \bar{d}_l\} = \{n, n-1, \dots, n+2-l\},$$

$$(5.18) \quad \{\bar{d}_1, \dots, \bar{d}_{k-1}\} \cup \{c_{k+1}, \dots, c_l\} = \{\bar{n}, \overline{n-1}, \dots, \overline{n+2-l}\}.$$

For example, these elements for all  $T'$  as in (5.15) of  $l \leq 4$  are given in Table 1.

Now we define  $\text{Tab}(C_n, \lambda/\mu)$  as the set of all the  $HV$ -tableaux  $T$  with the following condition:

**(E-2C)** Let  $T'$  be any subtableau of  $T$  (excluding  $a_1, \dots, a_k, b_{k+1}, \dots, b_l$ )

$$(5.19) \quad T' = \begin{array}{c} \boxed{c_1} \ a_1 \\ \vdots \\ \boxed{c_k} \ a_k \\ b_{k+1} \ \boxed{c_{k+1}} \\ \vdots \\ b_l \ \boxed{c_l} \end{array} \subset T$$

such that  $l \geq 2$ ,  $c_1 = n + 2 - l$ ,  $c_l = \overline{n + 2 - l}$ ,  $c_k \preceq n$ ,  $c_{k+1} \succeq \bar{n}$ , and every proper subtableau in  $T'$  satisfies the extra condition **(E-1C)**. Let  $(i_1, j_1)$  be the position of the top of the subtableau  $T'$  in (5.19) (i.e., the position of  $c_1$ ). Then one of the following conditions holds:

- (1)  $(i_1 + i - 1, j_1 - 1) \in \lambda/\mu$  and  $a_i := T(i_1 + i - 1, j_1 + 1) \prec d_i(T')$  for some  $1 \leq i \leq k$ .
- (2)  $(i_1 + i - 1, j_1 + 1) \in \lambda/\mu$  and  $b_i := T(i_1 + i - 1, j_1 - 1) \succ d_i(T')$  for some  $k + 1 \leq i \leq l$ .

We remark that the extra rule **(E-2C)** is reduced to the extra rule **(E-1C)**, if  $l(\lambda') = 1$ .

We conjecture that

**Conjecture 5.9.** *For any skew diagram  $\lambda/\mu$  of  $l(\lambda') = 2$  and  $l(\lambda) \leq n + 1$ , the equality (5.5) holds.*

**Theorem 5.10.** *Conjecture 5.9 is true for  $l(\lambda) \leq 4$ .*

*Proof.* If  $l(\lambda) \leq 3$ , then the extra rule **(E-2C)** for  $l(\lambda) \leq 3$  coincides with the extra rule **(E-2R)** with **(E-3R)**. For a summary of the proof for  $l(\lambda) = 4$ , which is parallel to that of Theorem 5.7, see the maps and their relations in the following diagram:

$$(5.20) \quad \begin{array}{ccccccc} P_2^\times & \sqcup & (P_2^{13;23})^\circ & \sqcup & (P_2^{12;34})^\circ & \sqcup & (P_2^{24;34})^\circ & = & P_2 \\ & & \downarrow f_2^{23} & \swarrow f_2^{13} & \searrow f_2^{34} & \swarrow f_2^{12} & \searrow f_2^{34} & \downarrow f_2^{24} & \\ & & P_1^{12} & \sqcup & P_1^{23} & \sqcup & P_1^{34} & = & P_1 \\ & & \downarrow f_1^{12} & & \downarrow f_1^{23} & & \downarrow f_1^{34} & & \\ \text{Im } g & \sqcup & & & P_0 & & & = & \tilde{P} \end{array}$$

Here,  $(P_2^{13;23})^\circ$  denotes  $P_2^{13;23}(C_n; \mu, \lambda)^\circ$ , for instance.

There does not exist  $\mathbf{p} \in P(C_n; \mu, \lambda)$  that contains more than two transposed pair of paths, and therefore,

$$P(C_n; \mu, \lambda) = P_0(C_n; \mu, \lambda) \sqcup P_1(C_n; \mu, \lambda) \sqcup P_2(C_n; \mu, \lambda).$$

As in the proof of Theorem 5.7, we define  $P_1^{ij}(C_n; \mu, \lambda)$  ( $1 \leq i < j \leq 4$ ) as the set of all  $\mathbf{p} = (p_1, \dots, p_4) \in P_1(C_n; \mu, \lambda)$  such that  $(p_i, p_j)$  is transposed. Then we have

$$P_1(C_n; \mu, \lambda) = P_1^{12}(C_n; \mu, \lambda) \sqcup P_1^{23}(C_n; \mu, \lambda) \sqcup P_1^{34}(C_n; \mu, \lambda).$$

Similarly, we define  $P_2^{ij;km}(C_n; \mu, \lambda)$  ( $1 \leq i < j \leq 4, 1 \leq k < m \leq 4$ ) as the set of all  $\mathbf{p} = (p_1, \dots, p_4) \in P_2(C_n; \mu, \lambda)$  such that  $(p_i, p_j)$  and  $(p_k, p_m)$  are transposed. Then we have

$$P_2(C_n; \mu, \lambda) = P_2^{13;23}(C_n; \mu, \lambda) \sqcup P_2^{12;34}(C_n; \mu, \lambda) \sqcup P_2^{24;34}(C_n; \mu, \lambda).$$

Let  $P_2^{13;23}(C_n; \mu, \lambda)^\times$  be the set that consists of all  $\mathbf{p} = (p_1, \dots, p_4) \in P_2^{13;23}(C_n; \mu, \lambda)$  which satisfy one of the following conditions, where  $u$  (resp.  $v = u - (2, 0)$ ) is the unique intersecting point of  $(p_1, p_3)$  (resp.  $(p_2, p_3)$ ) at height 0:

- (1) Both points  $u + (-1, 1)$  and  $v + (1, -1)$  are on  $\mathbf{p}$ .
- (2) All four points  $u + (-1, 1)$ ,  $v + (1, -2)$ ,  $v + (-1, 1)$  and  $v + (0, 2)$  are on  $\mathbf{p}$ .

Let  $P_2^{24;34}(C_n; \mu, \lambda)^\times$  be the set of all  $\mathbf{p} \in P_2^{24;34}(C_n; \mu, \lambda)$  such that  $\omega(\mathbf{p}) \in P_2^{13;23}(C_n; \tilde{\mu}, \tilde{\lambda})^\times$ , where  $\omega$  is a map that rotates  $\mathbf{p}$  by 180 degrees defined as in (B.3). Let  $P_2^{12;34}(C_n; \mu, \lambda)^\times$  be the set that consists of all  $\mathbf{p} = (p_1, \dots, p_4) \in P_2^{12;34}(C_n; \mu, \lambda)$  such that all four points  $u + (-1, 1)$ ,  $u + (-2, 2)$ ,  $w + (1, -1)$  and  $w + (2, -2)$  are on  $\mathbf{p}$ , where  $u$  and (resp.  $w = u - (3, 0)$ ) is the unique intersecting point of  $(p_1, p_2)$  (resp.  $(p_3, p_4)$ ) at height 0. Let



$T'$	$\begin{array}{ c } \hline n \\ \hline \bar{n} \\ \hline \end{array}$	$\begin{array}{ c } \hline n-1 \\ \hline n \\ \hline n-1 \\ \hline \end{array}$	$\begin{array}{ c } \hline n-1 \\ \hline \bar{n} \\ \hline n-1 \\ \hline \end{array}$	$\begin{array}{ c } \hline n-2 \\ \hline n-1 \\ \hline n \\ \hline n-2 \\ \hline \end{array}$	$\begin{array}{ c } \hline n-2 \\ \hline n-1 \\ \hline \bar{n} \\ \hline n-2 \\ \hline \end{array}$	$\begin{array}{ c } \hline n-2 \\ \hline n-1 \\ \hline n-1 \\ \hline n-2 \\ \hline \end{array}$	$\begin{array}{ c } \hline n-2 \\ \hline n \\ \hline n-1 \\ \hline n-2 \\ \hline \end{array}$	$\begin{array}{ c } \hline n-2 \\ \hline \bar{n} \\ \hline n-1 \\ \hline n-2 \\ \hline \end{array}$
$d_1$	$\bar{n}$	$n$	$\bar{n}$	$n-1$	$n-1$	$n$	$n$	$\bar{n}$
$d_2$	$n$	$\bar{n}$	$n$	$n$	$\bar{n}$	$\bar{n}$	$\bar{n}$	$n$
$d_3$		$n$	$\bar{n}$	$\bar{n}$	$n$	$n$	$n$	$\bar{n}$
$d_4$				$n$	$\bar{n}$	$\bar{n}$	$n-1$	$n-1$

TABLE 1. The table of  $(d_1, \dots, d_l)$  for one-column tableaux  $T'$  as in (5.15) of  $l \leq 4$ .

$P_2^{13;23}(C_n; \mu, \lambda)^\circ := P_2^{13;23}(C_n; \mu, \lambda) \setminus P_2^{13;23}(C_n; \mu, \lambda)^\times$ , etc. We can define a weight-preserving, sign-inverting injection

$$f_2^{ij} : P_2^{km;k'm'}(C_n; \mu, \lambda)^\circ \rightarrow P_1(C_n; \mu, \lambda), \quad (i, j) = (k, m), (k', m'),$$

$$f_1^{ij} : P_1^{ij}(C_n; \mu, \lambda) \rightarrow P_0(C_n; \mu, \lambda),$$

which resolve the transposed pair  $(p_i, p_j)$  of  $\mathbf{p} = (p_1, \dots, p_4) \in P_k(C_n; \mu, \lambda)$  as the maps  $f_2^{ij}, f_1^{ij}$  in the proof of Theorem 5.7. These maps can also be defined as the composition of the maps  $r_y^{ij}$  given in Section B.1. We remark that  $P_2^{km;k'm'}(C_n; \mu, \lambda)^\circ$  consists of all  $\mathbf{p} \in P_2^{km;k'm'}(C_n; \mu, \lambda)$  such that  $f_2^{ij}$  for some  $1 \leq i < j \leq 4$  is well-defined (in fact, all  $f_2^{ij}$  are well-defined), while  $P_2^{km;k'm'}(C_n; \mu, \lambda)^\times$  consists of all  $\mathbf{p} \in P_2^{km;k'm'}(C_n; \mu, \lambda)$  such that  $f_2^{ij}$  for any  $1 \leq i < j \leq 4$  is not well-defined. These maps satisfy

$$\begin{aligned} \text{Im}(f_1^{34} \circ f_2^{12}) &= \text{Im}(f_1^{12} \circ f_2^{34}) = \text{Im} f_1^{12} \cap \text{Im} f_1^{34}, \\ \text{Im}(f_1^{23} \circ f_2^{13}) &= \text{Im}(f_1^{12} \circ f_2^{23}) = \text{Im} f_1^{12} \cap \text{Im} f_1^{23}, \\ \text{Im}(f_1^{34} \circ f_2^{24}) &= \text{Im}(f_1^{23} \circ f_2^{34}) = \text{Im} f_1^{23} \cap \text{Im} f_1^{34}, \\ \text{Im} f_1^{12} \cap \text{Im} f_1^{23} \cap \text{Im} f_1^{34} &= \phi, \end{aligned}$$

which can be proved by using the forms of the subtableaux in  $T(\mathbf{p})$  of  $\mathbf{p} \in \text{Im} f_1^{ij}$  for  $(i, j) = (1, 2), (2, 3), (3, 4)$  (see Table 1 and Figure 9). We can also define a weight-preserving, sign-preserving injection

$$g : P_2(C_n; \mu, \lambda)^\times \rightarrow \tilde{P}(C_n; \mu, \lambda)$$

on  $P_2(C_n; \mu, \lambda)^\times := P_2^{13;23}(C_n; \mu, \lambda)^\times \sqcup P_2^{12;34}(C_n; \mu, \lambda)^\times \sqcup P_2^{24;34}(C_n; \mu, \lambda)^\times$ , which satisfies  $\text{Im} g \sqcup P_0(C_n; \mu, \lambda) = \tilde{P}(C_n; \mu, \lambda)$ , as in the proof of Theorem 5.7. Then we similarly obtain the equality (5.5) by the following lemma.  $\square$

**Lemma 5.11.** *Let  $\lambda/\mu$  be a skew diagram of  $l(\lambda') \leq 2$  and  $l(\lambda) = n + 1$ . For  $\mathbf{p} \in \tilde{P}(C_n; \mu, \lambda)$ ,  $\mathbf{p} \in \text{Im} f_1^{12} \cup \text{Im} f_1^{23} \cup \text{Im} f_1^{34}$  if and only if  $T(\mathbf{p})$  is prohibited by **(E-2C)**. (See Figure 9 for example.)*

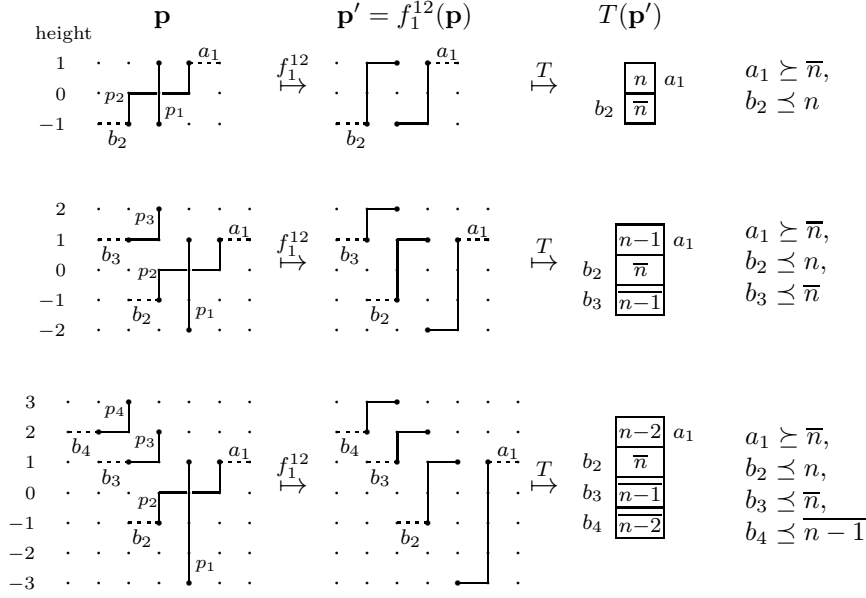

FIGURE 9. Examples of  $\mathbf{p} = (p_1, \dots, p_4) \in P_1^{12}(C_n; \mu, \lambda)$ , the map  $f_1^{12} : P_1^{12}(C_n; \mu, \lambda) \rightarrow P_0(C_n; \mu, \lambda)$ , and the sub-tableaux of  $T(f_1^{23}(\mathbf{p}))$ . If the (E) step for  $a_i$  (resp.  $b_i$ ) exists, then  $a_i$  (resp.  $b_i$ ) satisfies the condition as above, which implies the corresponding tableau is prohibited by **(E-2C)**.

#### APPENDIX A. CLASSICAL PROJECTION OF $\chi_{\lambda,a}$

In this section, we give a “classical projection” of the determinant  $\chi_{\lambda,a}$  in (2.23), the one obtained by dropping the spectral parameters  $a \in \mathbb{C}$ . We prove that the classical projection of  $\chi_{\lambda,a}$  coincides with the character for the representation of  $U_q(\mathfrak{g})$  defined in [9].

Let  $\beta : \mathbb{Z}[Y_{i,a}^{\pm 1}]_{i=1,\dots,n;a \in \mathbb{C}} \rightarrow \mathbb{Z}[y_i^{\pm 1}]_{i=1,\dots,n}$  be the classical projection, i.e., the algebra homomorphism defined by  $\beta(Y_{i,a}) = y_i$ . Identifying  $\mathcal{Z}$  with  $\mathcal{Y}$  by the isomorphism in the proof of Proposition 2.1,  $\beta|_{\mathcal{Z}}$  is the map  $\mathcal{Z} \rightarrow \mathbb{Z}[z_i^{\pm 1}]_{i=1,\dots,N}$  such that  $\beta(z_{i,a}) = z_i$ ,  $\beta(z_{0,a}) = 1$  (for  $B_n$ ) and  $\beta(z_{i,a}) = z_i^{-1}$  (for  $B_n, C_n$  and  $D_n$ ). The homomorphism  $\beta$  sends the  $q$ -character  $\chi_q(V)$  for any finite dimensional representation  $V$  of  $U_q(\hat{\mathfrak{g}})$  to the character  $\chi(V)$  of  $U_q(\mathfrak{g})$  for  $V$  as a  $U_q(\mathfrak{g})$ -module [15].

Let  $\chi_{\lambda,a}$  be the determinant (2.23) with  $\mu = \phi$ . Let  $\chi_\lambda \in \mathbb{Z}[z_i^{\pm 1}]_{i=1,\dots,N}$  be the character of  $\mathfrak{g}$  for the irreducible representation with highest weight  $\lambda$ . For any partitions  $\mu, \nu, \lambda$ , let  $c_{\mu\nu}^\lambda$  be the Littlewood-Richardson coefficient [25]. Then we have

**Theorem A.1.** For any  $\lambda$  such that  $l(\lambda) \leq n$ ,

$$(A.1) \quad \beta(\chi_{\lambda,a}) = \begin{cases} \chi_{\lambda}, & \text{if } \mathfrak{g} \text{ is of type } A_n, \\ \sum_{\kappa,\mu} c_{(2\kappa)',\mu}^{\lambda} \chi_{\mu}, & B_n, \\ \sum_{\kappa,\mu} c_{2\kappa,\mu}^{\lambda} \chi_{\mu}, & C_n, \\ \sum_{\kappa,\mu} c_{(2\kappa)',\mu}^{\lambda} \tilde{\chi}_{\mu}, & D_n, \end{cases}$$

where

$$\tilde{\chi}_{\lambda} := \begin{cases} \chi_{\lambda}, & \text{if } 1 \leq l(\lambda) \leq n-1, \\ \chi_{\lambda} + \chi_{\sigma(\lambda)}, & \text{if } l(\lambda) = n, \end{cases}$$

for  $D_n$ , where  $\sigma$  is induced from the automorphism of the Dynkin diagram.

*Proof.* Let  $\Lambda$  be the graded ring of symmetric functions with countable many variables  $z_1, z_2, \dots$ , and let  $S_{\lambda} \in \Lambda$  be the *Schur function*. It is well-known that  $S_{\lambda}$  satisfies the Jacobi-Trudi identity

$$S_{\lambda} = \det(h_{\lambda_i - i + j})_{1 \leq i, j \leq l(\lambda)} = \det(e_{\lambda'_i - i + j})_{1 \leq i, j \leq l(\lambda')},$$

where  $h_i, e_i \in \Lambda$  are defined as

$$\prod_{k=1}^{\infty} (1 - z_k x)^{-1} = \sum_{i=0}^{\infty} h_i x^i, \quad \prod_{k=1}^{\infty} (1 + z_k x) = \sum_{i=0}^{\infty} e_i x^i.$$

Let  $\varphi : \Lambda \rightarrow \Lambda$  be the algebra automorphism defined by

$$\begin{aligned} \varphi(e_i) &= e_i - e_{i-2}, & \varphi^{-1}(e_i) &= \sum_{m=0}^{\infty} e_{i-2m}, \\ \varphi(h_i) &= \sum_{m=0}^{\infty} h_{i-2m}, & \varphi^{-1}(h_i) &= h_i - h_{i-2}. \end{aligned}$$

(All the four conditions are equivalent to each other.)

Set  $\Lambda_n := \mathbb{Z}[z_1, \dots, z_n]^{\mathfrak{S}_n}$ . Let  $\pi_{n+1} : \Lambda \rightarrow \Lambda_{n+1}/\langle z_1 \cdots z_{n+1} - 1 \rangle$  be the map induced from the natural projection  $\Lambda \rightarrow \Lambda_{n+1}$  and let  $\pi_{Sp(2n)}$  and  $\pi_{O(N)}$  be the *specialization homomorphisms* in [23]. We define  $\rho_n$  as

$$\rho_n = \begin{cases} \pi_{n+1}, & (A_n) \\ \pi_{O(2n+1)} \circ \varphi^{-1}, & (B_n) \\ \pi_{Sp(2n)} \circ \varphi, & (C_n) \\ \pi_{O(2n)} \circ \varphi^{-1}. & (D_n) \end{cases}$$

By the properties of  $\pi_{O(N)}$  and  $\pi_{Sp(2n)}$  [23] and the definitions of  $h_{i,a}$  and  $e_{i,a}$  in (2.21) and (2.20), we have  $\beta(\chi_{\lambda,a}) = \rho_n(S_{\lambda})$  for any Young diagram  $\lambda$  of  $l(\lambda) \leq n$ . Therefore, for  $A_n$ , (A.1) is obvious by the fact that  $\pi_{n+1}(S_{\lambda}) = \chi_{\lambda}$ ,

while for  $B_n$ ,  $C_n$  and  $D_n$ , (A.1) are obtained by the equalities [30, 23]

$$\begin{aligned} \prod_{i,j \geq 1} \frac{1}{(1 - z_i \tilde{z}_j)} &= \sum_{\lambda} S_{\lambda}(z) S_{\lambda}(\tilde{z}), \\ \frac{\prod_{1 \leq i < j} (1 - \tilde{z}_i \tilde{z}_j)}{\prod_{i,j \geq 1} (1 - z_i \tilde{z}_j)} &= \sum_{\lambda} \chi_O(\lambda)(z) S_{\lambda}(\tilde{z}), \\ \frac{\prod_{1 \leq i < j} (1 - \tilde{z}_i \tilde{z}_j)}{\prod_{i,j \geq 1} (1 - z_i \tilde{z}_j)} &= \sum_{\lambda} \chi_{Sp}(\lambda)(z) S_{\lambda}(\tilde{z}), \end{aligned}$$

where  $\chi_{Sp}(\lambda), \chi_O(\lambda) \in \Lambda$  are the *universal character* of  $Sp$  and  $O$  [23], and the Littlewood's Lemma [24]

$$\prod_{1 \leq i \leq j} \frac{1}{(1 - z_i z_j)} = \sum_{\kappa} S_{2\kappa}(z), \quad \prod_{1 \leq i < j} \frac{1}{(1 - z_i z_j)} = \sum_{\kappa} S_{(2\kappa)'}(z).$$

□

*Remark A.2.* The right hand side of (A.1) is the character of the representation  $W_G(\lambda)$  defined in [9]. Therefore, by Theorem A.1, under the classical projection, Conjecture 2.2 reduces to Conjecture 2 in [9] of the existence of an irreducible representation of  $U_q(\hat{\mathfrak{g}})$ , which is proved by [8] for  $\lambda = (i^m)$  such that  $m \geq 1$  and  $1 \leq i \leq n$  ( $A_n$  and  $B_n$ ),  $1 \leq i \leq n-1$  ( $C_n$ ),  $1 \leq i \leq n-2$  ( $D_n$ ).

## APPENDIX B. THE WEIGHT-PRESERVING MAPS FOR $C_n$ CASE

In this section, we define some weight-preserving maps and give their properties which we use in the proof of Theorems 5.6 and 5.7.

**B.1. The map  $r_y$ .** In this subsection, we give weight-preserving maps for a pair of  $h$ -paths of type  $C_n$ . These maps are used to define the maps in Section B.2. First, we define the map  $r_y$  for  $y = 0, 1, \dots, n-1$ , which is defined on all  $(p_1, p_2) \in P(C_n) \times P(C_n)$  that satisfy certain condition  $(\mathbf{R}_y)$ .

Set  $(x, y) \pm (x', y') := (x \pm x', y \pm y')$ .

Let  $y = 1, \dots, n-1$ . For any  $p_1, p_2 \in P(C_n)$ , let  $w_1$  (resp.  $w_2$ ) be the leftmost point of height  $-y$  on  $p_1$  (resp. the rightmost point of height  $y$  on  $p_2$ ), i.e., if  $w_1 = (x_1, -y)$  and  $w_2 = (x_2, y)$ , then

$$x_1 = \min\{x \mid (x, -y) \text{ is on } p_1\}, \quad x_2 = \max\{x \mid (x, y) \text{ is on } p_2\}.$$

See Figure 10 for example. Note that  $w_1 - (0, 1)$  is on  $p_1$  and  $w_2 + (0, 1)$  is on  $p_2$ . We define the condition  $(\mathbf{R}_y)$  for any  $p_1, p_2 \in P(C_n)$  as follows:

$(\mathbf{R}_y)$   $w_1^* := w_1 + (-y-1, 2y)$  is on  $p_2$  and  $w_2^* := w_2 + (y+1, -2y)$  is on  $p_1$ .

For any  $p_1, p_2 \in P(C_n)$  which satisfy  $(\mathbf{R}_y)$ , we define  $r_y(p_1, p_2) = (p'_1, p'_2)$

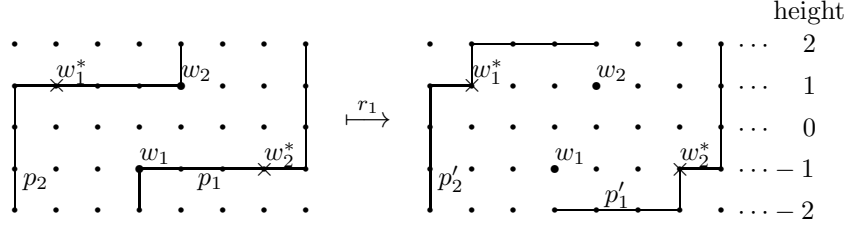

FIGURE 10. An example of two paths and the map  $r_y$  for  $y = 1$ .

( $y = 1, \dots, n - 1$ ) as (see Figure 10)

$$(B.1) \quad \begin{aligned} p'_1 &: u_1 \xrightarrow{p_1} w_1 - (0, 1) \longrightarrow w_2^* - (0, 1) \longrightarrow w_2^* \xrightarrow{p_1} v_1, \\ p'_2 &: u_2 \xrightarrow{p_2} w_1^* \longrightarrow w_1^* + (0, 1) \longrightarrow w_2 + (0, 1) \xrightarrow{p_2} v_2. \end{aligned}$$

For the  $y = 0$  case, let  $p_1, p_2 \in P(C_n)$  satisfy the following condition:

$$(R_0) \quad (p_1, p_2) \text{ is specially intersecting at height } 0.$$

Then we define  $r_0(p_1, p_2) = (p'_1, p'_2)$  as follows: If  $p_1$  and  $p_2$  are not transposed, then let  $w_1$  (resp.  $w_2$ ) be the leftmost point of height 0 on  $p_1$  (resp. the rightmost point of height 0 on  $p_2$ ), and set  $w_1^*$  and  $w_2^*$  as in  $(R_y)$  by putting  $y = 0$ . Then set  $(p'_1, p'_2)$  as in (B.1). If  $(p_1, p_2)$  is transposed (see Figure 11 for example), then let  $u$  (resp.  $v$ ) be the leftmost (resp. rightmost) intersecting point of  $p_1$  and  $p_2$  at height 0. We assume that  $u - (0, 1)$  and  $v + (0, 1)$  is on  $p_1$  while  $u - (1, 0)$  and  $v + (1, 0)$  is on  $p_2$ . Set  $r_0(p_1, p_2) = (p'_1, p'_2)$  by

$$\begin{aligned} p'_1 &: u_1 \xrightarrow{p_1} u - (0, 1) \longrightarrow v + (1, -1) \longrightarrow v + (1, 0) \xrightarrow{p_2} v_1, \\ p'_2 &: u_2 \xrightarrow{p_2} u - (1, 0) \longrightarrow u + (-1, 1) \longrightarrow v + (0, 1) \xrightarrow{p_1} v_2. \end{aligned}$$

(Roughly speaking,  $r_0$  “resolves” the transposed pair  $(p_1, p_2)$ .) By (2.4) and the definition of the  $h$ -label of type  $C_n$ , we have

**Lemma B.1.**  $r_y$  ( $y = 0, \dots, n - 1$ ) preserves the weight of  $(p_1, p_2)$ .

Let  $1 \leq i < j \leq l$ . For any  $\mathbf{p} = (p_1, \dots, p_l)$  such that the pair  $(p_i, p_j)$  satisfies  $(R_y)$  ( $0 \leq y \leq n - 1$ ), we define  $r_y^{ij}(\mathbf{p}) = (p'_1, \dots, p'_l)$  by

$$(B.2) \quad (p'_i, p'_j) := r_y(p_i, p_j), \quad p'_k := p_k, \quad (k \neq i, j).$$

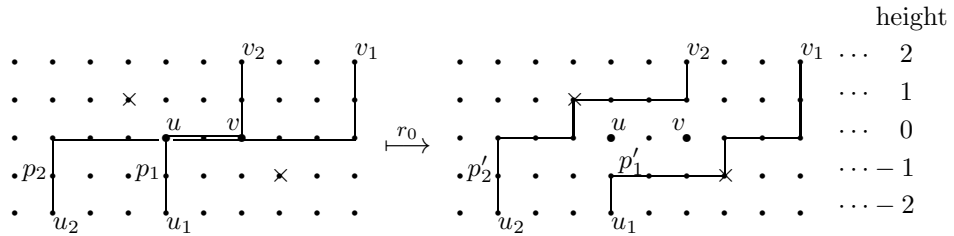

FIGURE 11. An example of specially intersecting, transposed paths and the map  $r_0$

By Lemma B.1, it is obvious that

**Proposition B.2.**  $r_y^{ij}$  preserves the weight for any  $0 \leq y \leq n-1$  and  $1 \leq i < j \leq l$ .

Remark that  $r_y^{ij}(\mathbf{p})$  for  $\mathbf{p} \in P(C_n; \mu, \lambda)$  may include an ordinarily intersecting pair of paths, which implies that  $r_y^{ij}(\mathbf{p})$  is not necessarily an element of  $P(C_n; \mu, \lambda)$ .

**B.2. The maps in the proof of Theorem 5.7.** In this subsection,  $\lambda/\mu$  is a skew diagram of  $l(\lambda) = 3$ . In this case, we have  $P(C_n; \mu, \lambda) = P_0(C_n; \mu, \lambda) \sqcup P_1(C_n; \mu, \lambda) \sqcup P_2(C_n; \mu, \lambda)$ . We define some maps which we use in Section 5.3 and show their properties.

*The map  $g$ .* For any  $\mathbf{p} = (p_1, p_2, p_3) \in P_2(C_n; \mu, \lambda)$ , let  $u$  be the leftmost intersecting point of  $p_1$  and  $p_3$ , and let  $v$  be the rightmost intersecting point of  $p_2$  and  $p_3$  (see Figure 12). Then set  $u' := u + (-1, 1)$  and  $v' := v + (1, -1)$ . Let  $P_2(C_n; \mu, \lambda)^\times$  be the set of all  $\mathbf{p} \in P_2(C_n; \mu, \lambda)$  such that both  $u'$  and  $v'$  are on some  $p_i$  (actually,  $u'$  is on  $p_2$  and  $v'$  is on  $p_1$ ). For example,  $\mathbf{p}$  in Figure 12 is an element of  $P_2(C_n; \mu, \lambda)^\times$ . Let  $\tilde{P}(C_n; \mu, \lambda)$  be the subset of  $\mathfrak{P}(C_n; \mathbf{u}_\mu, \mathbf{v}_\lambda)$  defined in Section 5.2. We define a map

$$g : P_2(C_n; \mu, \lambda)^\times \rightarrow \tilde{P}(C_n; \mu, \lambda)$$

as follows: For  $\mathbf{p} = (p_1, p_2, p_3) \in P_2(C_n; \mu, \lambda)^\times$ , set  $g(\mathbf{p}) = (p'_1, p'_2, p'_3)$  as (see Figure 12)

$$\begin{aligned} p'_1 : u_1 &\xrightarrow{p_1} v' \longrightarrow v' + (0, 1) \xrightarrow{p_3} v_1, \\ p'_2 : u_2 &\xrightarrow{p_2} v \longrightarrow u \xrightarrow{p_1} v_2, \\ p'_3 : u_3 &\xrightarrow{p_3} u' - (0, 1) \longrightarrow u' \xrightarrow{p_2} v_3. \end{aligned}$$

Then we easily show that

**Lemma B.3.** (1)  $g$  is a weight-preserving, sign-preserving injection and  $\tilde{P}(C_n; \mu, \lambda) = \text{Im } g \sqcup P_0(C_n; \mu, \lambda)$ .

$$(2) \{T(\mathbf{p}) \mid \mathbf{p} \in \text{Im } g\} = \{T \in \widetilde{\text{Tab}}(C_n; \lambda/\mu) \mid T \text{ contains } \begin{array}{|c|c|} \hline \overline{n} & n \\ \hline \overline{n} & n \\ \hline \overline{n} & n \\ \hline \end{array}\}.$$

*The maps  $f_2^{13}$  and  $f_2^{23}$ .* Let  $P_1^{ij}(C_n; \mu, \lambda)$  ( $1 \leq i < j \leq 3$ ) be the set of all  $\mathbf{p} = (p_1, p_2, p_3) \in P_1(C_n; \mu, \lambda)$  such that  $(p_i, p_j)$  is transposed. Then we have  $P_1(C_n; \mu, \lambda) = P_1^{12}(C_n; \mu, \lambda) \sqcup P_1^{23}(C_n; \mu, \lambda)$ . Let  $P_2(C_n; \mu, \lambda)^\circ := P_2(C_n; \mu, \lambda) \setminus P_2(C_n; \mu, \lambda)^\times$ . We define a map

$$f_2^{13} : P_2(C_n; \mu, \lambda)^\circ \rightarrow P_1^{23}(C_n; \mu, \lambda)$$

as follows, using the weight-preserving maps  $r_y^{ij}$  defined in (B.2) (roughly speaking,  $f_2^{13}$  resolves the transposed pair  $(p_1, p_3)$  of  $\mathbf{p} = (p_1, p_2, p_3) \in P_2(C_n; \mu, \lambda)^\circ$ , let  $u$  be the leftmost intersecting point of  $p_1$  and  $p_3$  and  $u' := u + (-1, 1)$ . Set  $\mathbf{p}' := (p'_1, p'_2, p'_3) = r_0^{13}(\mathbf{p})$ , which is well-defined. Then

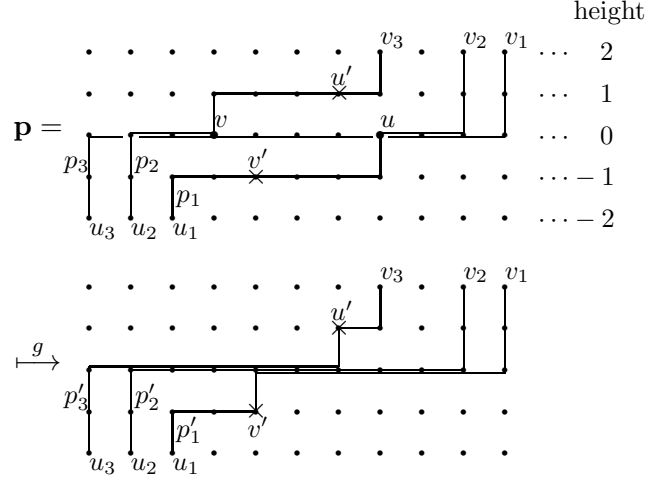

FIGURE 12. An example of  $\mathbf{p} \in P_2(C_n; \mu, \lambda)^\times$  and the map  $g$ .

**Case ( $f_2^{13}$ -a)** If  $u'$  is not on any  $p_i$ , set  $f_2^{13}(\mathbf{p}) = \mathbf{p}'$ , which is in  $P_1^{23}(C_n; \mu, \lambda)$ . (Otherwise,  $u'$  is on  $p_2$  and  $(p'_2, p'_3)$  is ordinarily intersecting.)

**Case ( $f_2^{13}$ -b)** Otherwise,  $(p'_1, p'_2)$  satisfies the condition  $(\mathbf{R}_1)$  in Appendix B.1. Set  $f_2^{13}(\mathbf{p}) = r_1^{12}(\mathbf{p}')$ , which is in  $P_1^{23}(C_n; \mu, \lambda)$  (see Figure 13).

We remark that if  $\mathbf{p} \in P_2(C_n; \mu, \lambda)^\times$ , then  $(p'_2, p'_3)$  is ordinarily intersecting, but the procedure of ( $f_2^{13}$ -b) is not well-defined, for  $(p'_1, p'_2)$  does not satisfy  $(\mathbf{R}_1)$ .

We also define

$$f_2^{23} : P_2(C_n; \mu, \lambda)^\circ \rightarrow P_1^{12}(C_n; \mu, \lambda)$$

by  $\omega \circ f_2^{13} \circ \omega$ , where

$$(B.3) \quad \omega : \mathfrak{P}(\mathbf{u}_\mu, \mathbf{v}_\lambda) \rightarrow \mathfrak{P}(\mathbf{u}_{\tilde{\mu}}, \mathbf{v}_{\tilde{\lambda}})$$

is a map that rotates  $\mathbf{p}$  by 180 degrees around a fixed point  $(x, 0)$  such that  $2x - \lambda_1 + l(\lambda) - 1 \in \mathbb{Z}_{\geq 0}$  (so that  $\tilde{\lambda}$  and  $\tilde{\mu}$  are partitions). Then,  $f_2^{23}$  resolves the transposed pair  $(p_2, p_3)$  of  $\mathbf{p} = (p_1, p_2, p_3) \in P_2(C_n; \mu, \lambda)^\circ$ .

Next, we give the conditions to describe the images of  $f_2^{13}$  and  $f_2^{23}$ . For any  $\mathbf{p} \in P_1^{23}(C_n; \mu, \lambda)$  (see Figure 14), let  $s_1$  be the leftmost point of height 1 on  $p_3$ ,  $s_2$  be the rightmost point of height  $-1$  on  $p_1$ ,  $s_3$  be the leftmost point of height 2 on  $p_2$ , and  $s_4$  be the rightmost point of height  $-2$  on  $p_1$ . For each  $i = 1, \dots, 4$ , set  $s'_i := s_i + (y, -2y)$ , where  $y$  is the height of  $s_i$ . If  $s'_2$  is on  $p_3$ , then we define  $k$  as the number of steps of  $p_3$  between  $s_1$  and  $s'_2$ . Then define conditions  $(\mathbf{F}_2^{13}$ -a) and  $(\mathbf{F}_2^{13}$ -b) for  $\mathbf{p} \in P_1^{23}(C_n; \mu, \lambda)$  as follows:

**( $\mathbf{F}_2^{13}$ -a)**  $\mathbf{p}$  satisfies all of the following conditions:

- $s'_1$  is on  $p_1$ .
- $s'_2$  is on  $p_3$  and  $k$  is odd.

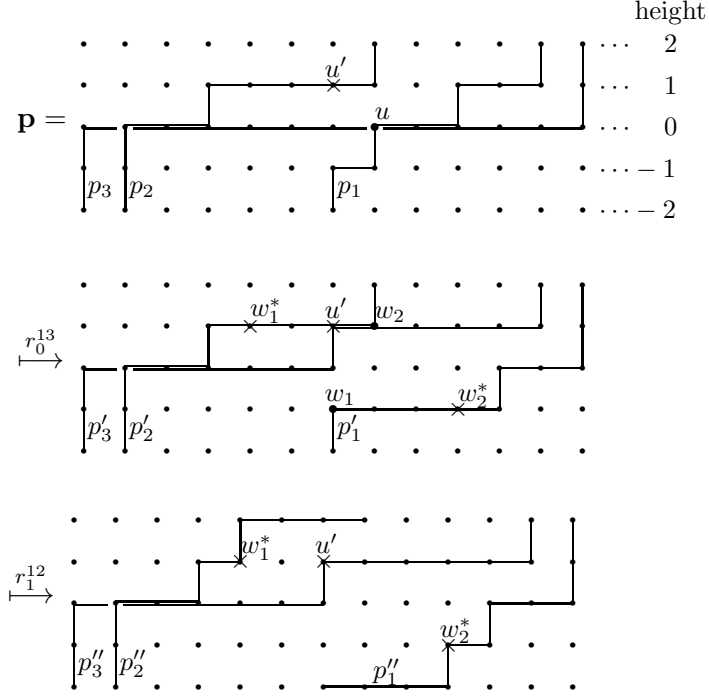

FIGURE 13. An example of  $\mathbf{p} \in P_2(C_n; \mu, \lambda)^\circ$  and the map  $f_2^{13}$  of Case  $(f_2^{13}\text{-b})$ .

**( $\mathbf{F}_2^{13}\text{-b}$ )**  $\mathbf{p}$  satisfies all of the following conditions:

- $s'_1$  is not on  $p_1$ .
- $s'_2$  is on  $p_3$  and  $k$  is odd.
- $s'_3$  is on  $p_1$ .
- $s'_4$  is on  $p_2$ .

We also define conditions **( $\mathbf{F}_2^{23}\text{-a}$ )** and **( $\mathbf{F}_2^{23}\text{-b}$ )** for  $\mathbf{p} \in P_1^{12}(C_n; \mu, \lambda)$  as follows:

**( $\mathbf{F}_2^{23}\text{-a}$ )**  $\omega(\mathbf{p})$  satisfies the condition **( $\mathbf{F}_2^{13}\text{-a}$ )**.

**( $\mathbf{F}_2^{23}\text{-b}$ )**  $\omega(\mathbf{p})$  satisfies the condition **( $\mathbf{F}_2^{13}\text{-b}$ )**.

For example,  $\mathbf{p} \in P_1^{23}(C_n; \mu, \lambda)$  in Figure 14 satisfies the condition **( $\mathbf{F}_2^{13}\text{-b}$ )**. Note that **( $\mathbf{F}_2^{13}\text{-a}$ )** and **( $\mathbf{F}_2^{13}\text{-b}$ )** (resp. **( $\mathbf{F}_2^{23}\text{-a}$ )** and **( $\mathbf{F}_2^{23}\text{-b}$ )**) are exclusive with each other.

We have

- Lemma B.4.** (1) For  $\mathbf{p} \in P_1(C_n; \mu, \lambda)$ ,
- (a)  $\mathbf{p} \in \text{Im } f_2^{13}$  if and only if either **( $\mathbf{F}_2^{13}\text{-a}$ )** or **( $\mathbf{F}_2^{13}\text{-b}$ )** is satisfied.
  - (b)  $\mathbf{p} \in \text{Im } f_2^{23}$  if and only if either **( $\mathbf{F}_2^{23}\text{-a}$ )** or **( $\mathbf{F}_2^{23}\text{-b}$ )** is satisfied.
- (2)  $f_2^{13}$  and  $f_2^{23}$  are weight-preserving, sign-inverting injections.

*Proof.* We prove it for  $f_2^{13}$ . We can check that  $\mathbf{p}$  in the image of  $(f_2^{13}\text{-a})$  satisfy **( $\mathbf{F}_2^{13}\text{-a}$ )**. Conversely, one can invert the procedure of  $(f_2^{13}\text{-a})$  for



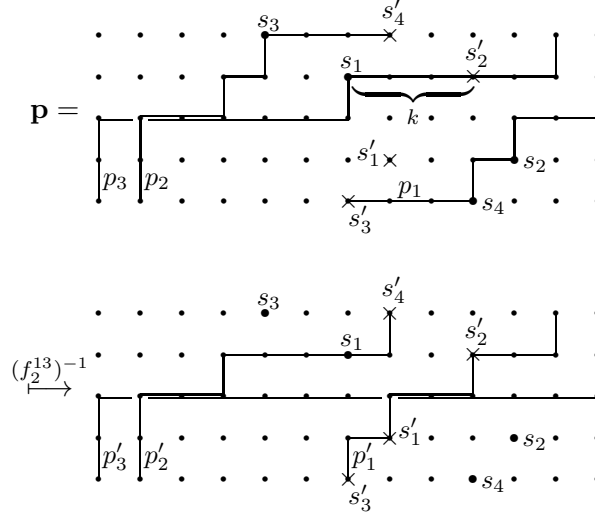

FIGURE 14. An example of  $\mathbf{p} \in P_1^{23}(C_n; \mu, \lambda)$  which satisfy  $(\mathbf{F}_2^{13}\text{-b})$ , and the inverse procedure of  $(f_2^{13}\text{-b})$

any  $\mathbf{p} \in P_1^{23}(C_n; \mu, \lambda)$  that satisfies  $(\mathbf{F}_2^{13}\text{-a})$ . The same holds when  $(f_2^{13}\text{-a})$  (resp.  $(\mathbf{F}_2^{13}\text{-a})$ ) are replaced with  $(f_2^{13}\text{-b})$  (resp.  $(\mathbf{F}_2^{13}\text{-b})$ ) (see Figure 14 for example).  $\square$

The maps  $f_1^{12}$  and  $f_1^{23}$ . We define a map

$$f_1^{12} : P_1^{12}(C_n; \mu, \lambda) \rightarrow P_0(C_n; \mu, \lambda),$$

as follows, using the weight-preserving maps  $r_y^{ij}$  defined in B.2 (roughly speaking,  $f_1^{12}$  resolves the transposed pair  $(p_1, p_2)$  of  $\mathbf{p} = (p_1, p_2, p_3)$  without producing any ordinarily intersecting paths): For any  $\mathbf{p} = (p_1, p_2, p_3) \in P_1^{12}(C_n; \mu, \lambda)$  (see Figure 15), let  $w_1$  be the leftmost point on  $p_1$  at height  $-1$  and  $w_1^* = w_1 + (-2, 2)$ . Let  $u$  be the leftmost intersecting point of  $p_1$  and  $p_2$  and  $u' := u + (-1, 1)$ . Set  $\mathbf{p}' := (p'_1, p'_2, p'_3) = r_0^{12}(\mathbf{p})$ , which is well-defined. Then

**Case  $(f_1^{12}\text{-a})$**  If  $u'$  is not on any  $p_i$ , set  $f_1^{12}(\mathbf{p}) = \mathbf{p}'$ , which is in  $P_0(C_n; \mu, \lambda)$ . (Otherwise,  $u'$  is on  $p_3$  and  $(p'_2, p'_3)$  is ordinarily intersecting. )

**Case  $(f_1^{12}\text{-b})$**  If  $u'$  is on  $p_3$  and  $w_1^*$  is on  $p_3$ , then  $(p'_1, p'_3)$  satisfies  $(\mathbf{R}_1)$ . Set  $f_1^{12}(\mathbf{p}) = r_1^{13}(\mathbf{p}')$ , which is in  $P_0(C_n; \mu, \lambda)$ . (If  $w_1^*$  is not on  $p_3$ , then  $r_1^{13}(\mathbf{p}')$  is not defined.)

**Case  $(f_1^{12}\text{-c})$**  Otherwise,  $(p_2, p_3)$  satisfies  $(\mathbf{R}_0)$ . If we set  $\mathbf{p}'' = r_0^{23}(\mathbf{p}') = (p''_1, p''_2, p''_3)$ , then  $(p''_1, p''_2)$  is ordinarily intersecting. For  $(p''_1, p''_3)$  satisfies  $(\mathbf{R}_1)$ , we set  $f_1^{12}(\mathbf{p}) = r_1^{13}(\mathbf{p}'')$ , which is in  $P_0(C_n; \mu, \lambda)$ .

We also define

$$f_1^{23} : P_1^{23}(C_n; \mu, \lambda) \rightarrow P_0(C_n; \mu, \lambda)$$

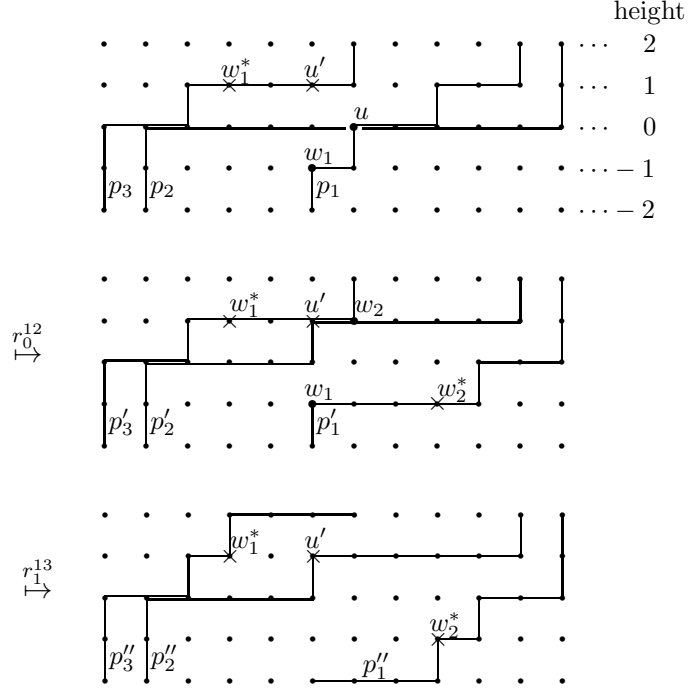

FIGURE 15. An example of  $\mathbf{p} \in P_1^{12}(C_n; \mu, \lambda)$  and the map  $f_1^{12}$  of Case  $(f_1^{12}\text{-b})$ .

as  $f_1^{23} := \omega \circ f_1^{12} \circ \omega$ , where  $\omega$  is the map defined in (B.3). Then  $f_1^{23}$  resolves the transposed pair  $(p_2, p_3)$  of  $\mathbf{p} = (p_1, p_2, p_3)$ .

Next, we give the conditions to describe the image of  $f_1^{12}$  and  $f_1^{23}$ . For any  $\mathbf{p} \in P_0(C_n; \mu, \lambda)$ , let  $s_i$  and  $s'_i$  ( $i = 1, \dots, 4$ ) be the points as in the conditions  $(\mathbf{F}_1^{12}\text{-a})$  and  $(\mathbf{F}_1^{12}\text{-b})$ , with the roles of  $p_2$  and  $p_3$  interchanged. Namely, (see Figure 16) let  $s_1$  be the leftmost point of height 1 on  $p_2$ ,  $s_2$  be the rightmost point of height  $-1$  on  $p_1$ ,  $s_3$  be the leftmost point of height 2 on  $p_3$ , and  $s_4$  be the rightmost point of height  $-2$  on  $p_1$ , and set  $s'_i := s_i + (y, -2y)$ , where  $y$  is the height of  $s_i$ . If  $s'_2$  is on  $p_2$ , then let  $k$  be the number of steps of  $p_2$  between  $s_1$  and  $s_2$ . Then define conditions  $(\mathbf{F}_1^{12}\text{-a})$  and  $(\mathbf{F}_1^{12}\text{-b})$  for  $\mathbf{p} \in P_0(C_n; \mu, \lambda)$  similar to the conditions  $(\mathbf{F}_2^{13}\text{-a})$  and  $(\mathbf{F}_2^{13}\text{-b})$ , with the roles of  $p_2$  and  $p_3$  in the conditions interchanged. Namely,

$(\mathbf{F}_1^{12}\text{-a})$   $\mathbf{p}$  satisfies all of the following conditions:

- $s'_1$  is on  $p_1$ .
- $s'_2$  is on  $p_2$  and  $k$  is odd.

$(\mathbf{F}_1^{12}\text{-b})$   $\mathbf{p}$  satisfies all of the following conditions:

- $s'_1$  is not on  $p_1$ .
- $s'_2$  is on  $p_2$  and  $k$  is odd.
- $s'_3$  is on  $p_1$ .
- $s'_4$  is on  $p_3$ .

We also define conditions  $(\mathbf{F}_1^{23}\text{-a})$  and  $(\mathbf{F}_1^{23}\text{-b})$  for  $\mathbf{p} \in P_0(C_n; \mu, \lambda)$  as follows:

- $(\mathbf{F}_1^{23}\text{-a})$   $\omega(\mathbf{p})$  satisfies the condition  $(\mathbf{F}_1^{12}\text{-a})$ .
- $(\mathbf{F}_1^{23}\text{-b})$   $\omega(\mathbf{p})$  satisfies the condition  $(\mathbf{F}_1^{12}\text{-b})$ .

Note that  $(\mathbf{F}_1^{12}\text{-a})$  and  $(\mathbf{F}_1^{12}\text{-b})$  (resp.  $(\mathbf{F}_1^{23}\text{-a})$  and  $(\mathbf{F}_1^{23}\text{-b})$ ) are exclusive with each other.

For any  $\mathbf{p} = (p_1, p_2, p_3) \in P_0(C_n; \mu, \lambda)$ , let  $s_3$  be the leftmost point of height 2 on  $p_3$  (as we defined in  $(\mathbf{F}_1^{23}\text{-a})$  and  $(\mathbf{F}_1^{23}\text{-b})$ ) and  $s_3'' := s_3 + (2, -3)$ . Let  $t$  be the leftmost point of height 1 on  $p_3$  and  $t' := t + (1, -2)$ . Let  $u$  be the rightmost point of height  $-1$  on  $p_2$ . We define conditions  $(\mathbf{F}_1^{12}\text{-b1})$ ,  $(\mathbf{F}_1^{12}\text{-b2})$ ,  $(\mathbf{F}_1^{23}\text{-b1})$ , and  $(\mathbf{F}_1^{23}\text{-b2})$  as follows (see Figure 16):

- $(\mathbf{F}_1^{12}\text{-b1})$   $\mathbf{p}$  satisfies  $(\mathbf{F}_1^{12}\text{-b})$  and  $s_3''$  is not on  $p_2$ .
- $(\mathbf{F}_1^{12}\text{-b2})$   $\mathbf{p}$  satisfies  $(\mathbf{F}_1^{12}\text{-b})$ ,  $s_3''$  is on  $p_2$ ,  $t'$  is on  $p_2$ , and the number of the steps from  $t'$  to  $u$  is even.
- $(\mathbf{F}_1^{23}\text{-b1})$   $\omega(\mathbf{p})$  satisfies  $(\mathbf{F}_1^{12}\text{-b1})$ .
- $(\mathbf{F}_1^{23}\text{-b2})$   $\omega(\mathbf{p})$  satisfies  $(\mathbf{F}_1^{12}\text{-b2})$ .

Then we have

- Lemma B.5.** (1) Let  $\mathbf{p} \in P_0(C_n; \mu, \lambda)$ . Then,  $\mathbf{p} \in \text{Im } f_1^{12}$  if and only if one of the conditions  $(\mathbf{F}_1^{12}\text{-a})$ ,  $(\mathbf{F}_1^{12}\text{-b1})$  and  $(\mathbf{F}_1^{12}\text{-b2})$  is satisfied. Similarly,  $\mathbf{p} \in \text{Im } f_1^{23}$  if and only if one of the conditions  $(\mathbf{F}_1^{23}\text{-a})$ ,  $(\mathbf{F}_1^{23}\text{-b1})$  and  $(\mathbf{F}_1^{23}\text{-b2})$  is satisfied.
- (2)  $f_1^{12}$  and  $f_1^{23}$  are weight-preserving sign-inverting injections.

The proof of Lemma B.5 is similar to that of Lemma B.4.

Finally, we give two lemmas which are used in Section 5.3.

- Lemma B.6.** (1)  $\text{Im } f_1^{12} \cap \text{Im } f_1^{23} = \text{Im } (f_1^{23} \circ f_2^{13})$ .
- (2)  $\text{Im } (f_1^{12} \circ f_2^{23}) = \text{Im } (f_1^{23} \circ f_2^{13})$ .

*Proof.* Using the conditions in Lemma B.5 (1), we can check that  $\mathbf{p} \in \text{Im } f_1^{12} \cap \text{Im } f_1^{23}$  if and only if  $\mathbf{p}$  satisfies one of the following:

- (a)  $\mathbf{p}$  satisfies  $(\mathbf{F}_1^{12}\text{-a})$  and  $(\mathbf{F}_1^{23}\text{-a})$ .
- (b)  $\mathbf{p}$  satisfies  $(\mathbf{F}_1^{12}\text{-a})$  and  $(\mathbf{F}_1^{23}\text{-b})$  ( $\Leftrightarrow$   $(\mathbf{F}_1^{12}\text{-a})$  and  $(\mathbf{F}_1^{23}\text{-b1})$ ).
- (c)  $\mathbf{p}$  satisfies  $(\mathbf{F}_1^{12}\text{-b})$  and  $(\mathbf{F}_1^{23}\text{-a})$  ( $\Leftrightarrow$   $(\mathbf{F}_1^{12}\text{-b1})$  and  $(\mathbf{F}_1^{23}\text{-a})$ ).

On the other hand,  $f_1^{23} \circ f_2^{13}$  is given as one of the following cases, by the conditions of  $\mathbf{p} \in \text{Im } f_2^{13}$ :

- (1)  $f_2^{13}$  as in Case  $(f_2^{13}\text{-a})$  and  $f_1^{23}$  as in Case  $(f_1^{23}\text{-a})$ .
- (2)  $f_2^{13}$  as in Case  $(f_2^{13}\text{-a})$  and  $f_1^{23}$  as in Case  $(f_1^{23}\text{-b})$ .
- (3)  $f_2^{13}$  as in Case  $(f_2^{13}\text{-b})$  and  $f_1^{23}$  as in Case  $(f_1^{23}\text{-a})$ .

As in the proof of Lemma B.4, all  $\mathbf{p} \in \text{Im } f_2^{13}$  of Case  $(f_2^{13}\text{-a})$  (resp. Case  $(f_2^{13}\text{-b})$ ) satisfy  $(\mathbf{F}_2^{13}\text{-a})$  (resp.  $(\mathbf{F}_2^{13}\text{-b})$ ). For the conditions  $(\mathbf{F}_2^{13}\text{-a})$  and  $(\mathbf{F}_2^{13}\text{-b})$  of  $\mathbf{p} \in \text{Im } f_2^{13}$  turn out to be the conditions  $(\mathbf{F}_1^{12}\text{-a})$  and  $(\mathbf{F}_1^{12}\text{-b})$  respectively after  $\mathbf{p}$  is sent by  $f_1^{23}$ , all  $\mathbf{p} \in \text{Im } f_1^{23} \circ f_2^{13}$  of case (1) satisfy (a), while that of (2) satisfy (b) and that of (3) satisfy (c). Thus, we obtain

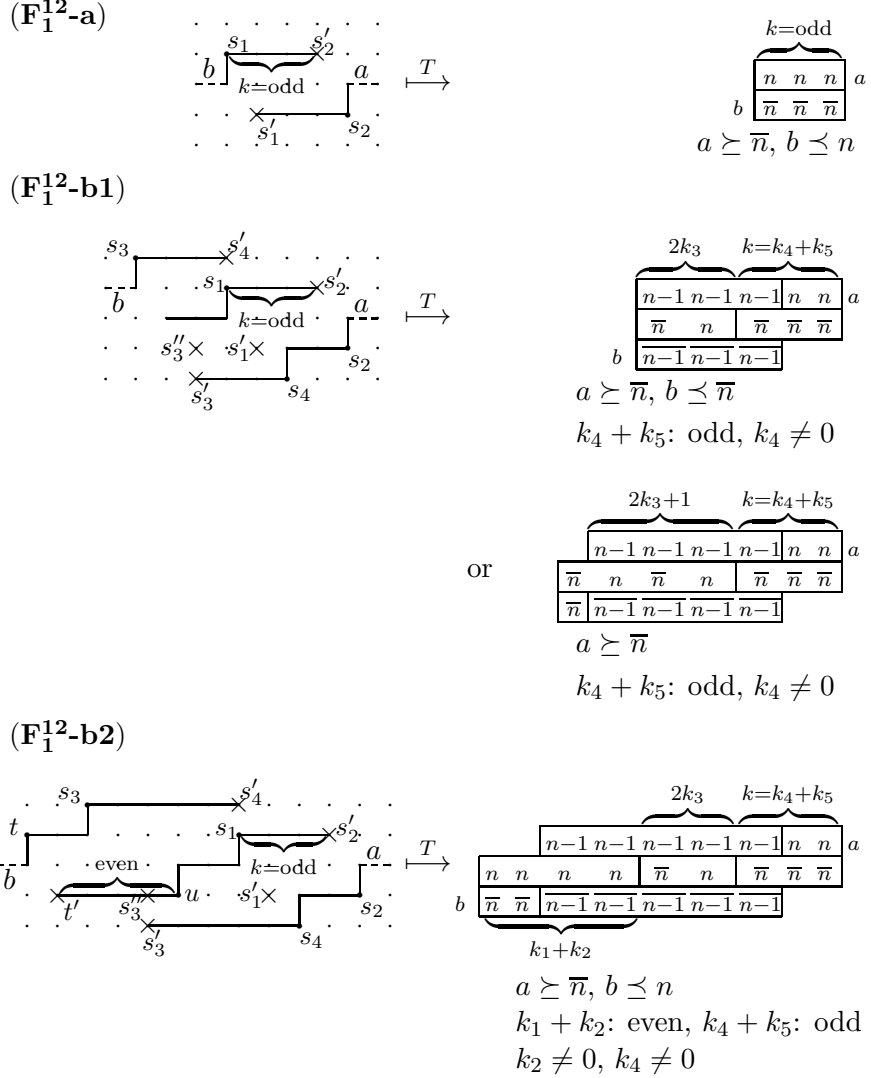

FIGURE 16. Examples of  $\mathbf{p} \in P_0(C_n; \mu, \lambda)$  which satisfy one of the conditions of  $\mathbf{p} \in \text{Im } f_1^{12}$  in Lemma B.5 (1) and the corresponding subtableau in  $T(\mathbf{p})$ . If the (E) step for  $a$  (resp.  $b$ ) exists, then  $a$  (resp.  $b$ ) satisfies the condition as above.

$\text{Im}(f_1^{23} \circ f_2^{13}) \subset \text{Im } f_1^{12} \cap \text{Im } f_1^{23}$ . Conversely,  $f_1^{12} \cap \text{Im } f_1^{23} \subset \text{Im}(f_1^{23} \circ f_2^{13})$  is obvious, and therefore, (1) is proved. The condition of  $\text{Im}(f_1^{12} \circ f_2^{23})$  is given similarly, and we obtain (2).  $\square$

**Lemma B.7.** For  $\mathbf{p} \in \tilde{P}(C_n; \mu, \lambda)$ ,  $\mathbf{p} \in \text{Im } f_1^{12} \cup \text{Im } f_1^{23}$  if and only if  $T(\mathbf{p}) \notin \text{Tab}(C_n, \lambda/\mu)$ , where  $\text{Tab}(C_n, \lambda/\mu)$  is the set of tableaux defined in Section 5.3.

*Proof.* If  $\mathbf{p} \in P_0(C_n; \mu, \lambda)$  satisfies one of the conditions of  $\mathbf{p} \in \text{Im } f_1^{12}$  or that of  $\mathbf{p} \in \text{Im } f_1^{23}$  in Lemma B.5 (1), then  $T(\mathbf{p})$  does not satisfy either the extra rule **(E-2R)** or the extra rule **(E-3R)** (see Figure 16).

Conversely, let  $\mathbf{p} \in \tilde{P}(C_n; \mu, \lambda)$  and  $T(\mathbf{p}) \notin \text{Tab}(C_n, \lambda/\mu)$ . By Lemma B.3 (2), there does not exist any  $\mathbf{p} \in \text{Im } g$  such that  $T(\mathbf{p})$  contains one of the subtableaux (5.6), (5.7), (5.8) and (5.9), and therefore,  $T(\mathbf{p}) \notin \text{Tab}(C_n, \lambda/\mu)$  implies that  $\mathbf{p} \in P_0(C_n; \mu, \lambda)$ , by Lemma B.3 (1). By assumption,  $T(\mathbf{p})$  contains a subtableau  $T'$  described as in (5.6), (5.7), (5.8) or (5.9) which does not satisfy the extra rule **(E-2R)** or **(E-3R)**. We can check that  $\mathbf{p}$  satisfies one of the conditions in Lemma B.5 (1) for all such  $T'$ . Namely (see Figure 16),

- (1) If  $T'$  is the subtableau (5.6) prohibited by the extra rule **(E-2R)**, then  $\mathbf{p}$  satisfies **(F<sub>1</sub><sup>12</sup>-a)** or **(F<sub>1</sub><sup>23</sup>-a)**.
- (2) If  $T'$  is the subtableau (5.7) prohibited by the extra rule **(E-3R)** and
  - (a) If  $k_4 + k_5$  is odd,  $k_4 \neq 0$  and  $k_2 = 0$ , then  $\mathbf{p}$  satisfies **(F<sub>1</sub><sup>12</sup>-b1)**.
  - (b) If  $k_4 + k_5$  is odd,  $k_4 \neq 0$  and  $k_2 \neq 0$ , then  $\mathbf{p}$  satisfies **(F<sub>1</sub><sup>12</sup>-b2)**.
  - (c) If  $k_4 + k_5$  is odd,  $k_4 = 0$  and  $k_2 \neq 0$ , then  $\mathbf{p}$  satisfies **(F<sub>1</sub><sup>12</sup>-a)**.
  - (d) If  $k_1 + k_2$  is odd,  $k_2 \neq 0$  and  $k_4 = 0$ , then  $\mathbf{p}$  satisfies **(F<sub>1</sub><sup>23</sup>-b1)**.
  - (e) If  $k_1 + k_2$  is odd,  $k_2 \neq 0$  and  $k_4 \neq 0$ , then  $\mathbf{p}$  satisfies **(F<sub>1</sub><sup>23</sup>-b2)**.
  - (f) If  $k_1 + k_2$  is odd,  $k_2 \neq 0$  and  $k_4 = 0$ , then  $\mathbf{p}$  satisfies **(F<sub>1</sub><sup>23</sup>-a)**.
- (3) If  $T'$  is the subtableau (5.8) (resp. (5.9)) prohibited by the extra rule **(E-3R)**, then  $\mathbf{p}$  satisfies **(F<sub>1</sub><sup>12</sup>-b1)** (resp. **(F<sub>1</sub><sup>23</sup>-b1)**).

□

## REFERENCES

- [1] T. Akasaka, M. Kashiwara, *Finite-dimensional representations of quantum affine algebras*, Publ. Res. Inst. Math. Sci. **33** (1997), no. 5, 839–867.
- [2] T. Arakawa, *private communication*.
- [3] T. Arakawa, *Drinfeld functor and finite-dimensional representations of Yangian*, Comm. Math. Phys. **205** (1999), no. 1, 1–18.
- [4] T. Arakawa, T. Suzuki, *Duality between  $\mathfrak{sl}_n(C)$  and the degenerate affine Hecke algebra*, J. Algebra **209** (1998), no. 1, 288–304.
- [5] R. J. Baxter, *Exactly Solved Models in Statistical Mechanics*, Academic Press, London, 1989.
- [6] V. V. Bazhanov, *Trigonometric solutions of triangle equations and classical Lie algebras*, Phys. Lett. B **159** (1985), 321–324.
- [7] V. V. Bazhanov, N. Reshetikhin, *Restricted solid-on-solid models connected with simply laced algebras and conformal field theory*, J. Phys. A **23** (1990), no. 9, 1477–1492.
- [8] V. Chari, *On the fermionic formula and the Kirillov-Reshetikhin conjecture*, Internat. Math. Res. Notices 2001, no. 12, 629–654.
- [9] V. Chari, M. Kleber, *Symmetric functions and representations of quantum affine algebras*, Contemp. Math. **297** (2002), 27–45.
- [10] V. Chari, A. Pressley, *Quantum affine algebras and their representations*, Canadian Math. Soc. Conf. Proc. **16** (1995), 59–78.
- [11] V. Chari, A. Pressley, *A Guide to Quantum Groups*, Cambridge University Press, Cambridge, 1995.

- [12] V. G. Drinfeld, *Quantum groups*, Proceedings of the International Congress of Mathematicians (Berkeley, Calif., 1986), vol. 1, 798–820, Amer. Math. Soc., Providence, RI, 1987.
- [13] E. Frenkel, E. Mukhin, *Combinatorics of  $q$ -characters of finite-dimensional representations of quantum affine algebras*, Comm. Math. Phys. **216** (2001), no. 1, 23–57.
- [14] E. Frenkel, N. Reshetikhin, *Quantum affine algebras and deformations of the Virasoro and  $\mathcal{W}$ -algebras*, Comm. Math. Phys. **178** (1996) 237–264.
- [15] E. Frenkel, N. Reshetikhin, *The  $q$ -characters of representations of quantum affine algebras and deformations of  $\mathcal{W}$ -algebras*, Contemp. Math. **248** (1999), 163–205.
- [16] I. Gessel, G. Viennot, *Binomial determinants, paths, and hook length formulae*, Adv. in Math. **58** (1985), no. 3, 300–321.
- [17] M. Jimbo, *A  $q$ -difference analogue of  $U(\mathfrak{g})$  and the Yang-Baxter equation*, Lett. Math. Phys. **10** (1985), no. 1, 63–69.
- [18] M. Jimbo, *Quantum  $R$  matrix for the generalized Toda system*, Comm. Math. Phys. **102** (1986), no. 4, 537–547.
- [19] P. P. Kulish, N. Y. Reshetikhin, E. K. Sklyanin, *Yang-Baxter equations and representation theory: I*, Lett. Math. Phys. **5** (1981), no. 5, 393–403.
- [20] A. Kuniba, Y. Ohta, J. Suzuki, *Quantum Jacobi-Trudi and Giambelli formulae for  $U_q(B_r^{(1)})$  from the analytic Bethe ansatz*, J. Phys. A **28** (1995), no. 21, 6211–6226.
- [21] A. Kuniba, M. Okado, J. Suzuki, Y. Yamada, *Difference  $L$  operators related to  $q$ -characters*, J. Phys. A **35** (2002), no.6, 1415–1435.
- [22] A. Kuniba, J. Suzuki, *Analytic Bethe ansatz for fundamental representations of Yan-gians*, Comm. Math. Phys. **173** (1995), no. 2, 225–264.
- [23] K. Koike, I. Terada, *Young-diagrammatic methods for the representation theory of the classical groups of type  $B_n, C_n, D_n$* , J. Algebra **107** (1987), no. 2, 466–511.
- [24] D. E. Littlewood, *The Theory of Group Characters and Matrix Representations of Groups*, 2nd ed., Oxford Univ. Press, London, 1950.
- [25] I. G. Macdonald, *Symmetric Functions and Hall Polynomials*, 2nd ed., Oxford Univ. Press, Oxford, 1995.
- [26] H. Nakajima,  *$t$ -analogs of  $q$ -characters of quantum affine algebras of type  $A_n, D_n$* , Contemp. Math. **325** (2003), 141–160.
- [27] N. Y. Reshetikhin, *Integrable models of quantum one-dimensional magnets with  $O(n)$ - and  $Sp(2k)$ -symmetries*, Theoret. Math. Phys. **63** (1985), no. 3, 555–569.
- [28] B. E. Sagan, *The Symmetric Group. Representations, Combinatorial Algorithms, and Symmetric Functions*, 2nd ed., Graduate Texts in Mathematics **203**, Springer-Verlag, New York, 2001.
- [29] A. Schilling, P. Sternberg, *Finite-dimensional crystals  $B^{2,s}$  for quantum affine algebras of type  $D_n^{(1)}$* , math.QA/0408113.
- [30] H. Weyl, *The Classical Groups. Their Invariants and Representations*, 2nd ed., Princeton Univ. Press, Princeton, N.J., 1946.