

Triangulated Manifolds with Few Vertices: Geometric 3-Manifolds

Frank H. Lutz

The understanding and classification of (compact) 3-dimensional manifolds (without boundary) is with no doubt one of the most prominent tasks in topology ever since Poincaré's fundamental work [88] on «l'analysis situs» appeared in 1904.

There are various ways for constructing 3-manifolds, some of which that are general enough to yield all 3-manifolds (orientable or nonorientable) and some that produce only particular types or classes of examples.

According to Moise [73], all 3-manifolds can be triangulated. This implies that there are only countably many distinct combinatorial (and therefore at most so many different topological) types that result from gluing together tetrahedra. Another way to obtain 3-manifolds is by starting with a solid 3-dimensional polyhedron for which surface faces are pairwise identified (see, e.g., Seifert [98] and Weber and Seifert [118]). Both approaches are rather general and, on the first sight, do not give much control on the kind of manifold we can expect as an outcome. However, if we want to determine the topological type of some given triangulated 3-manifold, then small or minimal triangulations play an important role as reference objects for recognition heuristics based on bistellar flips; see [7].

Further frequently used methods to get all orientable 3-manifolds are via composition of two handle bodies of the same genus (*Heegaard splitting*; see Heegaard [33], Seifert and Threlfall [101, §63], Hempel [34, Ch. 2] and Stillwell [103, Ch. 8.3]), via surgery on a link in the 3-sphere S^3 (cf. Dehn [21], Seifert and Threlfall [100, §65], Lickorish [58], and Wallace [117]) or via three-fold branched coverings of S^3 over a knot (see Alexander [1], Hilden [37], Montesinos [74], and Izmostiev and Joswig [43]).

In this article, we explicitly construct small triangulations for a number of well-known 3-dimensional manifolds and give a brief outline of some aspects of the underlying theory of 3-manifolds and its historical development.

1 Geometrization of 3-Manifolds

The intensive study of non-Euclidean geometries in the late 19th century, in particular by Klein [52], led, as one consequence, to the famous *Clifford-Klein space form problem*. This problem, posed by Killing [50] in 1891, asks for a classification of all (Riemannian) manifolds of constant curvature that arise as quotients X^d/G , where X^d is either the d -dimensional sphere S^d , the d -dimensional Euclidean space E^d , or the d -dimensional hyperbolic space H^d , and G is a discrete group of isometries which acts freely on X^d . The resulting manifolds are called *spherical*, *flat*, or *hyperbolic*, respectively. (This modern formulation of the Clifford-Klein space form problem is by Hopf [42].)

The three-dimensional spherical space forms were classified by Hopf [42] and by Threlfall and Seifert ([106], [107]). The classification of compact flat 3-manifolds is due to Nowacki [79] up to homeomorphisms, due to Hantzsche and Wendt [31] in the affine case, and was generalized by Wolf [120, Sec. 3.5] to the isometric and noncompact case. Hyperbolic 3-manifolds turned out to be much harder to understand. At the beginning, it was not even clear whether there are closed hyperbolic 3-manifolds at all. A first series of examples was constructed by Löbell in 1931 [59], and in 1933 Weber and Seifert [118] presented their hyperbolic dodecahedral space. The picture completely changed when Thurston [108] discovered that almost every prime 3-manifold is hyperbolic. For surveys on hyperbolic 3-manifolds see Thurston ([111], [110]), Benedetti and Petronio [3], and McMullen [66]. Milnor [71] is an exposition of the development of hyperbolic geometry. Commented English translations of classical papers by Beltrami, Klein, and Poincaré on hyperbolic geometry can be found in Stillwell [104].

In dimension two, every surface M^2 is a Clifford-Klein manifold. If the Euler characteristic $\chi(M^2)$ is positive, then M^2 is spherical, which gives the 2-sphere S^2 and the real projective plane $\mathbb{R}P^2$. The only two flat 2-manifolds with $\chi = 0$ are the 2-torus T^2 and the Klein bottle K . All other surfaces are hyperbolic and have negative Euler characteristic.

In dimension three, there are, besides the Clifford-Klein spaces, manifolds that are *homogeneous* but not *isotropic* (i.e., they look the same at every point but differently when we look in different directions). The sphere product $S^2 \times S^1$ is an example for such a space: This manifold can be modeled as a quotient of the simply connected space $S^2 \times \mathbb{R}^1$.

In a unifying approach for a geometric description of all 3-manifolds, Thurston [108] introduced the concept of *model geometries* as potential building blocks. For surveys on the geometrization of 3-manifolds see the electronic edition [110] of the 1980 lecture notes and the book [111] of Thurston as well as the comprehensive article of Scott [97].

Definition 1 (Thurston [111, 3.8.1]) *A **model geometry** (X, G) consists of a simply connected (and connected) manifold X together with a transitive Lie group G of diffeomorphisms of X , such that G has compact point stabilizers and is maximal with this property. Moreover it is required that there is at least*

one compact manifold M modeled on (X, G) as a quotient X/H with respect to a discrete fixed point free subgroup $H \subset G$.

Any model geometry carries a homogeneous G -invariant metric. For dimension two the model spaces X are precisely the spaces of constant curvature S^2 , E^2 , and H^2 .

Theorem 2 (Thurston [111, 3.8.4]) *There are eight 3-dimensional model geometries (X, G) , namely the isotropic ones S^3 , E^3 , and H^3 , and the anisotropic ones $S^2 \times \mathbb{R}^1$, $H^2 \times \mathbb{R}^1$, $\widetilde{SL}(2, \mathbb{R})$, Nil, and Sol.*

If a closed 3-manifold can be modeled on one of the eight geometries, then the respective geometry is unique.

Conjecture 3 (Thurston's Geometrization Conjecture [108]) *Every compact 3-manifold can be decomposed canonically into geometric pieces.*

The decomposition is as follows. In a first step, the manifold is split into a connected sum of (finitely many) prime factors; see Kneser [54], Milnor [68], Haken [26], and Jaco and Tollefson [45]. In a second step, each prime factor is then cut along a finite family of certain nontrivially embedded tori. This second step was formulated by Johannson [46] and Jaco and Shalen [44] (see also Thurston [108], Scott [97] and Neumann and Swarup [78]) and leaves as the open part of the conjecture to show that each resulting piece can be modeled on one of the eight geometries.

Thurston's Geometrization Conjecture holds in many cases. For example, all compact, prime 3-manifolds with nonempty boundary and all Haken manifolds are geometric [109]. Recent progress towards the Geometrization Conjecture has been achieved by Perelman ([84], [85], [86]), based on work by Hamilton ([27], [28]) on the Ricci flow on three-manifolds.

All eight model geometries are Lie groups, and, with the exception of H^3 , all are unimodular. Compact quotients of the spaces S^3 , E^3 , $\widetilde{SL}(2, \mathbb{R})$, Nil, and Sol that arise from discrete subgroups acting by left (or right) multiplication were classified by Raymond and Vasquez [90], based on partial results by Auslander, Green, and Hahn [2, Ch. III].

Six of the geometries, $S^2 \times \mathbb{R}^1$, S^3 , E^3 , Nil, $H^2 \times \mathbb{R}^1$, and $\widetilde{SL}(2, \mathbb{R})$, are Seifert manifolds and will be discussed in the next sections.

2 Seifert Manifolds

In 1933, Seifert (see [99] and the English translation [101]) described a large class of 3-manifolds, which revolutionized 3-manifold theory at that time. In the following we give a summary of the main definitions and theorems following Seifert [99] and Orlik [81].

Definition 4 *A 3-manifold is a **Seifert manifold** if it can be decomposed into a disjoint union of simple closed curves so that every such fiber has a (closed) fibered solid torus as a tubular neighborhood.*

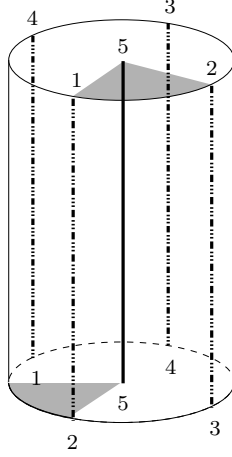

Figure 1: Fibered solid torus with $\mu = 4$ and $\nu = 1$.

Any *fibered solid torus* is obtained by starting with an upright cylinder for which the top and the bottom side are identified by a twist of a rational angle $2\pi\frac{\nu}{\mu}$, where μ and ν are coprime integers. If the cylinder is fibered into straight line segments parallel to its center axis, then the resulting torus is fibered into closed circles. Replacing ν by $\nu + k\mu$ or by $-\nu$ yields, up to a fiber preserving homeomorphism, the same fibered solid torus. Therefore, without loss of generality, it can be assumed that $\mu > 0$ and $0 \leq \nu \leq \frac{1}{2}\mu$.

Figure 1 displays a fibered solid torus with $\mu = 4$ and $\nu = 1$, i.e., the top and the bottom of the cylinder are identified by a twist of $\pi/2$. The dashed fiber is composed of the four line segments 1–2, 2–3, 3–4, 4–1 on the toroidal boundary surface. Every other fiber of the solid torus is composed of four line segments as well, with the exception of the center fiber, which consists of one line segment only.

Two fibered solid tori can be mapped onto each other by a fiber preserving homeomorphism if and only if the respective parameters μ and ν are the same. If the tubular neighborhood of a fiber in a Seifert manifold has parameter $\mu > 1$, then the fiber is a μ -fold *exceptional fiber*; if $\mu = 1$, then the fiber is a *regular fiber*.

Theorem 5 (Seifert [99]) *Every Seifert manifold has at most finitely many exceptional fibers.*

The set of all fibers in a Seifert manifold M^3 , equipped with the quotient topology, is a closed (orientable or nonorientable) 2-dimensional surface, called the *orbit surface* of M^3 .

If M^2 is any surface, then $M^2 \times S^1$ is a Seifert manifold with fibers $\{x\} \times S^1$, $x \in M^2$, and orbit surface M^2 . Here, obviously, the orbit surface M^2 can be embedded into $M^2 \times S^1$, but this need not be the case in general.

If M^3 has r exceptional fibers, then we can *drill out* these fibers by removing disjoint open tubular neighborhoods of the r fibers. This way we obtain a fibered space with r toroidal boundary components. We can close this space by *filling in* regular solid tori in order to obtain a Seifert manifold with no exceptional fibers that still has the same orbit surface. However, there are, in general, different ways to do this, which requires to first classify all Seifert manifolds without exceptional fibers.

Theorem 6 (Seifert [99]) *If from a Seifert manifold without exceptional fibers one removes an open tubular neighborhood of an arbitrary regular fiber, then the resulting “classifying space” (with toroidal boundary) is of one of six distinct possible types.*

The classifying spaces are denoted as $\{Oo, g\}$, $\{On, g\}$, $\{No, g\}$, $\{NnI, g\}$, $\{NnII, g\}$, $\{NnIII, g\}$, where the capital letters O and N stand for the orientability respectively nonorientability of the total space and the small letters o and n for an orientable respectively nonorientable (punctured) orbit surface of genus g . Note that, in general, there are three different types I , II , and III of nonorientable classifying spaces in the case of a nonorientable orbit surface of genus g .

The type $\{Oo, g\}$. Orientable Seifert manifolds M^3 with orientable orbit surface have a particularly simple description. Those without exceptional fibers can be obtained as follows. Start with a (once) *punctured* orientable surface of genus g , i.e., remove an open disk from the surface. Then form the topological direct product with a circle S^1 . The resulting fibered space is the classifying space $\{Oo, g\}$ and has one toroidal boundary component.

Let M be a simple closed oriented curve on the boundary torus T^2 of a solid torus V . If M is nullhomotopic in V but not contractible on T^2 , then M is called a *meridian*. If, in addition, the solid torus V is fibered, then every simple closed curve on the boundary torus T^2 that intersects each fiber exactly once is a *crossing curve*.

In a next step we close $\{Oo, g\}$ by gluing in a regular solid torus. For this let Q_0 be the boundary circle of the (embedded) punctured surface and let H_0 be a fiber of the fibered boundary torus of $\{Oo, g\}$. Furthermore, let M_0 be a simple closed curve on the boundary torus homotopy equivalent to $Q_0 + bH_0$, i.e.,

$$M_0 \sim Q_0 + bH_0,$$

where b is any integer. Then there is a unique regular fibered solid torus V whose boundary torus can be mapped under a fiber preserving map onto the boundary torus of $\{Oo, g\}$ such that M_0 is nullhomotopic in V .

In Figure 2 and Figure 3 (left) we display the boundary torus of $\{Oo, g\}$ together with a curve $M_0 \sim Q_0 + 1 \cdot H_0$ that becomes a meridian on the boundary of the corresponding fibered solid torus in Figure 3 (right).

By closing the boundary torus of the classifying space $\{Oo, g\}$ we obtain for every integer b a different *class space* $\{Oo, g \mid b\}$ (without exceptional fibers).

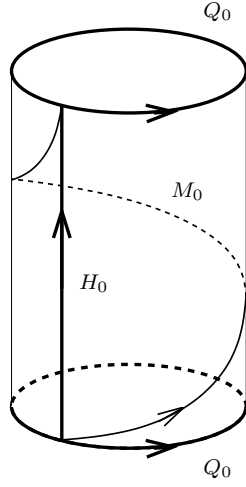

Figure 2: Boundary torus with $M_0 \sim Q_0 + 1 \cdot H_0$.

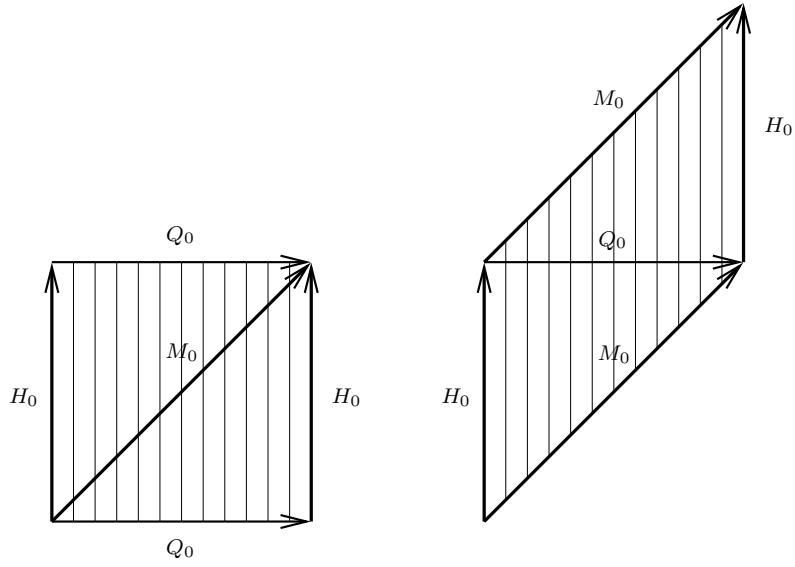

Figure 3: Fibered boundary torus with $M_0 \sim Q_0 + 1 \cdot H_0$.

Orientable Seifert manifolds with an orientable orbit surface of genus g and with $r > 0$ exceptional fibers can be constructed in a similar manner. We start again with the orientable surface of genus g . We remove $r + 1$ disjoint open discs such that the resulting surface has $r + 1$ boundary circles Q_0, Q_1, \dots, Q_r . Then we form the product with S^1 , and get a 3-manifold with $r + 1$ toroidal boundary components. As above, we seal the boundary torus that has the crossing curve Q_0 with a regular torus corresponding to the parameter b . On the other boundary tori we consider curves

$$M_i \sim \alpha_i Q_i + \beta_i H_i, \quad i = 1, \dots, r,$$

for fibers H_1, \dots, H_r and pairwise prime integers α_i and β_i , which, without loss of generality, can be chosen such that

$$\alpha_i > 1 \quad \text{and} \quad 0 < \beta_i < \alpha_i.$$

Then for each such M_i there is a unique fibered solid torus (with parameters α_i and β_i) which has the curve M_i as meridian. By gluing in these tori we obtain a Seifert manifold $\{Oo, g \mid b; (\alpha_1, \beta_1), \dots, (\alpha_r, \beta_r)\}$ with r exceptional fibers determined by the parameters (α_i, β_i) , $i = 1, \dots, r$, and every Seifert manifold with classifying space $\{Oo, g\}$ arises this way.

The type $\{No, g\}$. In this case the classifying space is not the topological product of the punctured orientable surface of genus g with S^1 anymore. Rather, the orientable surface of genus g is cut into the corresponding fundamental polygon (see [103, Ch. 1.3]) and punctured by cutting off the vertices.

The fundamental polygon of the orientable surface of genus 1, i.e., of the 2-torus T^2 , is a square with identified opposite oriented edges a and b , and is depicted as the top side (as well as the bottom side) of the cube in Figure 4.

In fact, before corresponding edges of the punctured fundamental polygon are identified, we take the product of the polygon (with cut off vertices) with an interval I . In Figure 4 this gives a vertical rectangular face for every edge of the original square and a shaded rectangular face for every cut off vertex of the square. Then the polygon on the top side is identified with the copy on the bottom side (so that we have the product of the polygon with cut off vertices with S^1). In a second step, white rectangular side faces are pairwise identified such that edge labels and arrows match. By flipping the side faces, the resulting total space $\{No, 1\}$ becomes nonorientable. Its boundary consists of the shaded faces that form a torus when glued together.

The same procedure can be carried out for the punctured fundamental polygon of any orientable surface of genus g and yields a nonorientable classifying space $\{No, g\}$ with a toroidal boundary.

The type $\{On, g\}$. As in the case $\{No, g\}$ we begin with the punctured fundamental polygon of the nonorientable surface of genus g , form the product with S^1 and identify side faces corresponding to edges of the fundamental

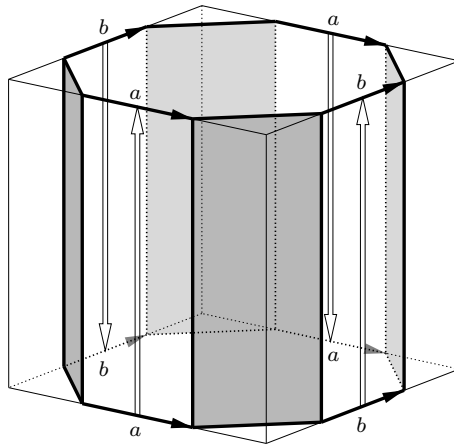

Figure 4: Classifying space $\{No, 1\}$.

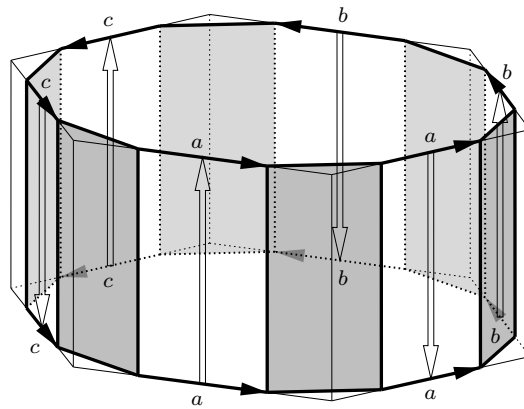

Figure 5: Classifying space $\{On, 3\}$.

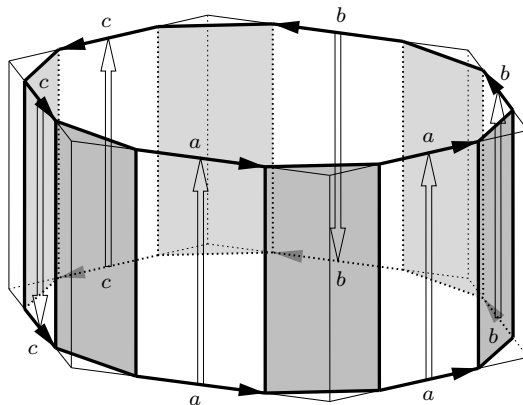

Figure 6: Classifying space $\{NnII, 3\}$.

polygon. In order to obtain an orientable total space, all side faces need to be flipped before identification. (See Figure 5 for the classifying space $\{On, 3\}$.)

The type $\{NnI, g\}$. If none of the side faces is flipped before identification, then the resulting classifying space $\{NnI, g\}$ is the product of the punctured nonorientable surface of genus g with S^1 .

The type $\{NnII, g\}$. In this case, all side faces are flipped before identification, except for one pair. This requires that $g \geq 2$. (See Figure 6 for the classifying space $\{NnII, 3\}$.)

The type $\{NnIII, g\}$. For a nonorientable surface of genus $g \geq 3$ and at least two pairs but not all pairs of side faces flipped before identification the resulting classifying space $\{NnIII, g\}$ is nonorientable but different from $\{NnII, g\}$.

In order to insert $r > 0$ exceptional fibers into one of these classifying spaces we proceed as in the case $\{Oo, g\}$ and remove r disjoint open discs from the starting polygon with cut off vertices before the product with I and the identifications of the side faces are carried out. We then get a space with $r + 1$ toroidal boundary components.

For the orientable space $\{On, g\}$ the closing procedure is as for $\{Oo, g\}$. For the nonorientable spaces the parameters α_i and β_i can be chosen (without loss of generality) such that

$$\alpha_i > 1 \quad \text{and} \quad 0 < \beta_i \leq \frac{1}{2}\alpha_i.$$

If $\alpha_i > 2$ for all $i = 1, \dots, r$, then the parameter b can be restricted to $b = 0$ or $b = 1$. If there is at least one i with $\alpha_i = 2$, then only the case $b = 0$ has to be considered.

Theorem 7 [99] *Every Seifert manifold is, up to fiber (and orientation) preserving homeomorphisms, of one of the following uniquely determined types:*

$$\begin{aligned} &\{Oo, g \mid b; (\alpha_1, \beta_1), \dots, (\alpha_r, \beta_r)\}, \\ &\{On, g \mid b; (\alpha_1, \beta_1), \dots, (\alpha_r, \beta_r)\}, \end{aligned}$$

with $\alpha_i > 1$, $0 < \beta_i < \alpha_i$, and integer b , or

$$\begin{aligned} &\{No, g \mid b; (\alpha_1, \beta_1), \dots, (\alpha_r, \beta_r)\}, \\ &\{NnI, g \mid b; (\alpha_1, \beta_1), \dots, (\alpha_r, \beta_r)\}, \\ &\{NnII, g \mid b; (\alpha_1, \beta_1), \dots, (\alpha_r, \beta_r)\}, \quad g \geq 2, \\ &\{NnIII, g \mid b; (\alpha_1, \beta_1), \dots, (\alpha_r, \beta_r)\}, \quad g \geq 3, \end{aligned}$$

with $\alpha_i > 1$, $0 < \beta_i \leq \frac{1}{2}\alpha_i$, and $b = 0$ or $b = 1$ (the latter only when all $\alpha_i > 2$).

Reversing the orientation yields

$$\{Oo, g \mid -r - b; (\alpha_1, \alpha_1 - \beta_1), \dots, (\alpha_r, \alpha_r - \beta_r)\}$$

respectively

$$\{On, g \mid -r - b; (\alpha_1, \alpha_1 - \beta_1), \dots, (\alpha_r, \alpha_r - \beta_r)\}$$

in the cases of orientable spaces.

It may occur that homeomorphic Seifert manifolds are defined by different sets of Seifert invariants and cannot be mapped onto each other by simply reversing the orientation (or by permuting the exceptional fibers). For example, for $\alpha \geq 2$ the Seifert manifolds $\{Oo, 0 \mid 0; (\alpha, 1)\}$ are all homeomorphic to the sphere S^3 .

Seifert manifolds contained in the following list are called *small* and were discussed by Orlik and Raymond [82] (see also [81, Ch. 5.3]):

$$\begin{aligned} &\{Oo, 0 \mid b\}, \{Oo, 0 \mid b; (\alpha_1, \beta_1)\}, \{Oo, 0 \mid b; (\alpha_1, \beta_1), (\alpha_2, \beta_2)\}, \\ &\{Oo, 0 \mid b; (\alpha_1, \beta_1), (\alpha_2, \beta_2), (\alpha_3, \beta_3)\} \text{ with } \frac{1}{\alpha_1} + \frac{1}{\alpha_2} + \frac{1}{\alpha_3} > 1, \\ &\{Oo, 0 \mid -2; (2, 1), (2, 1), (2, 1), (2, 1)\}, \\ &\{Oo, 1 \mid b\}, \{No, 1 \mid b\}, \\ &\{On, 1 \mid b\}, \{NnI, 1 \mid b\}, \{On, 1 \mid b; (\alpha_1, \beta_1)\}, \{NnI, 1 \mid b; (\alpha_1, \beta_1)\}, \\ &\{On, 2 \mid b\}, \{NnI, 2 \mid b\}, \{NnII, 2 \mid b\}. \end{aligned}$$

Some of the small Seifert manifolds are homeomorphic although they have different sets of defining Seifert invariants. All Seifert manifolds not in the list are called *large*.

Large Seifert manifolds were classified up to homeomorphism by Orlik, Vogt, and Zieschang [83]:

Theorem 8 [83] *If M and N are two large Seifert manifolds, then the following statements are equivalent:*

- (a) M and N have the same Seifert invariants (up to orientation reversion),
- (b) M and N are homeomorphic,
- (c) M and N have isomorphic fundamental groups.

Moreover, it follows from work of Waldhausen ([115], [116]) that every large Seifert manifold M is *irreducible*, i.e., every embedded 2-sphere in M bounds a 3-ball in M . In particular, all large Seifert manifolds are prime. With the exception of $S^2 \times S^1$, $S^2 \times S^1$, and $\mathbb{R}\mathbb{P}^3 \# \mathbb{R}\mathbb{P}^3$ also all small Seifert manifolds are irreducible. Both 2-sphere bundles over S^1 are prime, which leaves $\mathbb{R}\mathbb{P}^3 \# \mathbb{R}\mathbb{P}^3$ as the only non-prime Seifert manifold.

Seifert manifolds appear in various settings, for example as complex hypersurfaces (see Section 11) or as quotients of the geometries $S^2 \times \mathbb{R}^1$, S^3 , E^3 , Nil, $H^2 \times \mathbb{R}^1$, and $\widetilde{SL}(2, \mathbb{R})$. However, it took until the early 1980s that a clear picture of the connections between these different concepts was reached. The main link is given by two invariants for a Seifert manifold M , the *Euler number* $e(M)$, introduced by Neumann and Raymond [77], and the *Euler characteristic* $\chi(X)$ of the base orbifold X of Thurston [110, Ch. 13]. If M is orientable, then

$$e(M) := -\left(b + \sum_{i=1}^r \frac{\beta_i}{\alpha_i}\right),$$

and $e(M) := 0$ if M is nonorientable. The Euler characteristic of the base orbifold is given by

$$\chi(X) := \chi(S) - \sum_{i=1}^r \left(1 - \frac{1}{\alpha_i}\right),$$

where $\chi(S)$ denotes the Euler characteristic of the orbit surface.

Theorem 9 (Scott [97, 5.3]) *The geometric type of a Seifert manifold depends only on the sign of the Euler characteristic χ of the base orbifold and on whether $e = 0$ or $e \neq 0$.*

The corresponding geometry of a Seifert manifold can be read off from Table 1. In particular, it follows that all S^3 -, Nil-, and $\widetilde{SL}(2, \mathbb{R})$ -spaces are orientable.

We will next discuss the different geometries, and we will construct triangulations for a number of spaces. There are only four manifolds modeled on the geometry $S^2 \times \mathbb{R}^1$ and only ten manifolds modeled on E^3 . We will give triangulations for all of these as well as for products and some twisted products of surfaces with S^1 . Triangulations of particular spherical 3-manifolds will be obtained geometrically via pairwise identifying boundary faces of well-known polyhedra.

Table 1: The six geometries of Seifert manifolds.

	$\chi > 0$	$\chi = 0$	$\chi < 0$
$e = 0$	$S^2 \times \mathbb{R}^1$	E^3	$H^2 \times \mathbb{R}^1$
$e \neq 0$	S^3	Nil	$\widetilde{SL}(2, \mathbb{R})$

Alternative to these constructions, an algorithmic procedure that yields concrete triangulations for *all* Seifert manifolds will be given in [10]. These triangulations can easily be produced with the GAP-program SEIFERT [61], which requires as input only the Seifert invariants.

3 $(S^2 \times \mathbb{R})$ -Spaces

Seifert [98] described in 1931 four quotient spaces of $S^2 \times \mathbb{R}$. Tollefson [113] then showed in 1974 that these are already all $(S^2 \times \mathbb{R})$ -spaces.

Theorem 10 (Tollefson [113]) *There are precisely four 3-manifolds modeled on $S^2 \times \mathbb{R}$, namely $S^2 \times S^1$, $S^2 \times S^1$, $\mathbb{R}P^2 \times S^1$, and $\mathbb{R}P^3 \# \mathbb{R}P^3$.*

In this section, we will see how triangulations for products and twisted products can be obtained. We will also list the Seifert invariants for the four $(S^2 \times \mathbb{R})$ -spaces.

Products. Let M be a triangulable m -dimensional and N be a triangulable n -dimensional manifold. Then their topological product $M \times N$ can be triangulated as follows. We start with a triangulation of M and a triangulation of N . In a first step, we form for every m -dimensional facet Δ_m of M the direct product with each n -dimensional facet Δ_n of N . The union of all these products of simplices $\Delta_m \times \Delta_n$ gives a cell-decomposition of $M \times N$ which then will be triangulated consistently in a second step.

One particular triangulation of the direct product $\Delta_m \times \Delta_n$ of an m -simplex Δ_m having vertices v_0, \dots, v_m with an n -simplex Δ_n having vertices w_0, \dots, w_n is the *staircase triangulation* described in [6], [25, Ch. 7], [56], and [95]. (See also [22, Ch. II §8].) The product $\Delta_m \times \Delta_n$ has the vertex set

$$\{(v_k, w_l) \mid 0 \leq k \leq m, 0 \leq l \leq n\},$$

which we identify with the vertex set of a rectangular grid, as in Figure 7. The $m + n + 1$ vertices of every (monotone increasing) lattice path from (v_0, w_0) to (v_m, w_n) define an $(m + n)$ -dimensional facet of $\Delta_m \times \Delta_n$. For example, there are altogether three lattice paths for the product $\Delta_2 \times \Delta_1$, which give a triangulation of the prism $\Delta_2 \times \Delta_1$ into the following three tetrahedra, $\{(v_0, w_0), (v_1, w_0), (v_2, w_0), (v_2, w_1)\}$, $\{(v_0, w_0), (v_1, w_0), (v_1, w_1), (v_2, w_1)\}$, and $\{(v_0, w_0), (v_0, w_1), (v_1, w_1), (v_2, w_1)\}$.

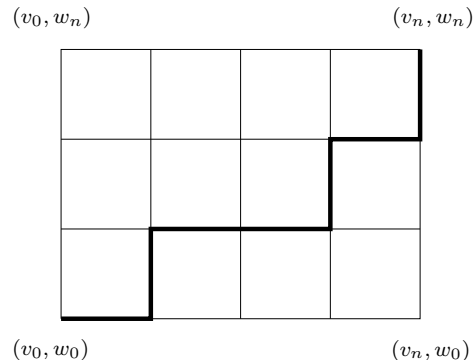

Figure 7: Staircase triangulation of $\Delta_m \times \Delta_n$.

If the vertex sets of the triangulations of M respectively N are totally ordered, then the union of the facets of the staircase triangulations of all the cells $\Delta_m \times \Delta_n$ of $M \times N$ yields a consistent *product triangulation* of $M \times N$. If the triangulations of M and N have s and t vertices and u and v facets, respectively, then the product triangulation of $M \times N$ has $s \cdot t$ vertices and $u \cdot v \cdot (m+n)!/(m!n!)$ maximal faces [56].

In Figure 8 we depict the product triangulation of $S^2 \times S^1$ where S^2 is triangulated as the boundary of the tetrahedron 1234. The four triangles 123, 124, 134, and 234 can be seen at the top and bottom of the figure. The circle S^1 is triangulated with three edges. For simplicity, we have not labeled the vertices of the product triangulation of $S^2 \times S^1$ in the figure with pairs of vertices of S^2 and S^1 . Instead, we used a set of 4 new vertices for every new “horizontal S^2 -layer”. With respect to this labeling the rectangular faces of the prisms are triangulated using the respective diagonal which contains the vertex with the smallest label in the rectangle. The triangulation of the three rectangular faces of every prism induces a unique triangulation of the prism itself into three tetrahedra.

Twisted Products over S^1 . Once we know how to triangulate direct products, then twisted products over S^1 are easy to describe.

Let M be a triangulated d -dimensional manifold with m vertices and let I be an interval triangulated with four vertices. The product triangulation of $M \times I$ has $4 \cdot m$ vertices and has as its boundary two disjoint copies of M . If we glue these copies of M together trivially by identifying the respective vertices, then we obtain a triangulation of $M \times S^1$ with $3 \cdot m$ vertices.

Instead of the trivial identification we can first apply any combinatorial automorphism of M to one of the boundary components of $M \times I$ before gluing the components together. This way we obtain *twisted product triangulations* of M over S^1 . Note that the homeomorphism type of the resulting manifolds will, in general, depend on the combinatorial automorphism that is used for the gluing.

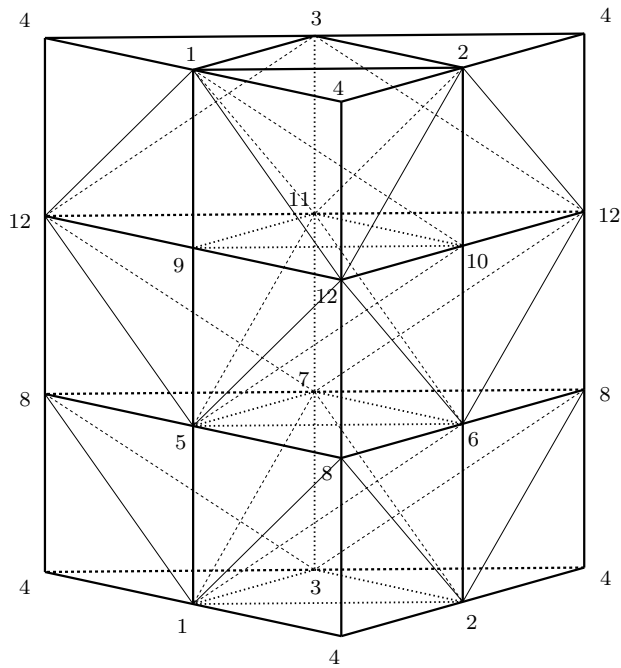

Figure 8: Product triangulation of $S^2 \times S^1$.

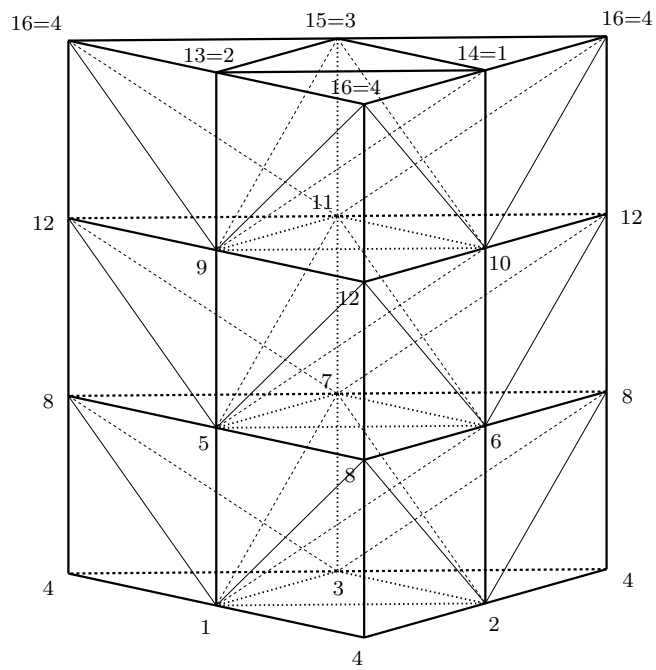

Figure 9: Triangulation of the twisted product $S^2 \times S^1$.

Topologically, this construction yields the *mapping torus* of a homeomorphism.

In Figure 9 the vertices 13 and 14 of the top copy of S^2 are flipped before the identification with the bottom copy, so the two copies of S^2 are glued together under a map that reverses the orientation of S^2 . The resulting space is the nonorientable twisted product $S^2 \rtimes S^1$. There are exactly two S^2 -bundles over S^1 [102, §26]. Thus we only need to take care whether we change the orientation of S^2 under the gluing or not.

If we start with any surface M^2 with f -vector $f = (f_0, f_1, f_2)$, then the product triangulation of $M^2 \times S^1$ or any twisted product triangulation of M^2 over S^1 has f -vector $f = (3f_0, 3f_0 + 6f_1, 6f_1 + 4f_2, 4f_2)$.

Let us next analyze which Seifert invariants can occur for $(S^2 \times \mathbb{R})$ -spaces. The Euler characteristic of the base orbifold X has to be greater than 0, i.e.,

$$\chi(X) = \chi(S) - \sum_{i=1}^r \left(1 - \frac{1}{\alpha_i}\right) > 0.$$

It follows that the orbit surface S has to be S^2 with $\chi(S^2) = 2$, or $\mathbb{R}\mathbf{P}^2$ with $\chi(\mathbb{R}\mathbf{P}^2) = 1$, since all other surfaces have Euler characteristic $\chi(S) \leq 0$ and since $1 > (1 - \frac{1}{\alpha_i}) \geq \frac{1}{2}$ for every exceptional fiber. It also follows that the number of exceptional fibers r is at most 3 for the orbit surface S^2 and at most 1 for $\mathbb{R}\mathbf{P}^2$.

If the orbit surface is S^2 , then the total space M is orientable. In particular, we need that

$$e(M) = -(b + \sum_{i=1}^r \frac{\beta_i}{\alpha_i}) = 0.$$

If $r = 0$, then necessarily $b = 0$. The case $r = 1$ cannot occur, since $\frac{\beta}{\alpha}$ is not an integer (thus $e(M) = -(b + \frac{\beta}{\alpha}) \neq 0$). For $r = 2$ it is $0 < \frac{\beta_1}{\alpha_1} + \frac{\beta_2}{\alpha_2} < 2$, so the sum $\frac{\beta_1}{\alpha_1} + \frac{\beta_2}{\alpha_2}$ has to be equal to 1, which can only be achieved for $\alpha_2 = \alpha_1$ and $\beta_2 = \alpha_1 - \beta_1$. In the case $r = 3$ we have for the base orbifold X that $\chi(X) > 0$ is equivalent to

$$\frac{1}{\alpha_1} + \frac{1}{\alpha_2} + \frac{1}{\alpha_3} > 1.$$

There are exactly four types of *platonic triples* of integers α_i for which the inequality holds: $(2, 2, \alpha_3)$, $(2, 3, 3)$, $(2, 3, 4)$, and $(2, 3, 5)$. However, in the first case $\sum_{i=1}^3 \frac{\beta_i}{\alpha_i} = \frac{1}{2} + \frac{1}{2} + \frac{\beta_3}{\alpha_3}$ is not an integer and this also can be deduced for the other platonic triples. Therefore, $r = 3$ is not possible.

Let the orbit surface be $\mathbb{R}\mathbf{P}^2$. If the total space is orientable, then the case $r = 1$ can be ruled out as above. Hence, $r = 0$ and $b = 0$. For a nonorientable total space $e(M) = 0$, so $r \leq 1$ is the only restriction.

The topological types of the resulting Seifert manifolds were determined by Orlik and Raymond [82]. In Table 2 we give the four $(S^2 \times \mathbb{R})$ -spaces together with their Seifert invariants and the f -vectors of their smallest known triangulations. The triangulations of $S^2 \rtimes S^1$ and $S^2 \times S^1$ are vertex-minimal.

Table 2: Smallest known triangulations of $(S^2 \times \mathbb{R})$ -spaces.

Manifold	Seifert Fibrations	Homology	f -Vector
$S^2 \times S^1$	$\{NnI, 1 \mid 1\}$ $\{NnI, 1 \mid b; (\alpha, \beta)\}$ with $b\alpha + \beta$ odd	$(\mathbb{Z}, \mathbb{Z}, \mathbb{Z}_2, 0)$	$(9, 36, 54, 27)$
$S^2 \times S^1$	$\{Oo, 0 \mid 0\}$, $\{Oo, 0 \mid -1; (\alpha, \beta), (\alpha, \alpha - \beta)\}$	$(\mathbb{Z}, \mathbb{Z}, \mathbb{Z}, \mathbb{Z})$	$(10, 40, 60, 30)$
$\mathbb{R}P^2 \times S^1$	$\{NnI, 1 \mid 0\}$ $\{NnI, 1 \mid b; (\alpha, \beta)\}$ with $b\alpha + \beta$ even	$(\mathbb{Z}, \mathbb{Z} \oplus \mathbb{Z}_2, \mathbb{Z}_2, 0)$	$(14, 84, 140, 70)$
$\mathbb{R}P^3 \# \mathbb{R}P^3$	$\{On, 1 \mid 0\}$	$(\mathbb{Z}, \mathbb{Z}_2^2, 0, \mathbb{Z})$	$(15, 86, 142, 71)$

They can, for example, be obtained from the product and the twisted product triangulation of S^2 over S^1 by applying bistellar flips to these.

Theorem 11 *The four $(S^2 \times \mathbb{R})$ -spaces have small triangulations with at most 15 vertices.*

More details on small triangulations of 3-manifolds with at most 15 vertices are given in [60].

4 Spherical Spaces

Spherical 3-dimensional Clifford-Klein manifolds were classified essentially by Hopf [42] in 1926 and were described in detail by Threlfall and Seifert in the early 1930s ([106], [107]). Before that time all the known examples of spherical 3-dimensional spaces were, in fact, quotients S^3/G of the Lie group $S^3 \cong SU(2)$ with respect to left (or right) multiplication of finite subgroups G of S^3 . The group S^3 is the simply connected double cover of the three-dimensional rotation group $SO(3) \cong \mathbb{R}P^3$. Finite subgroups of $SO(3)$ were already determined by Klein ([51], [53]). These are the cyclic groups \mathbb{Z}_n of order n , the dihedral groups D_n of order $2n$, the tetrahedral group T of order 12, the octahedral group O of order 24, and the icosahedral group I of order 60.

The double cover of \mathbb{Z}_n in S^3 is the cyclic group \mathbb{Z}_{2n} , the double covers of the other groups are the respective binary groups; see Table 3.

The full group of orientation-preserving isometries of S^3 is $SO(4)$. (Since orientation-reversing isometries have fixed points, these are not of interest here.) Discrete subgroups G of $SO(4)$ that act freely on S^3 are finite. Spherical 3-manifolds that arise as quotients S^3/G therefore have finite fundamental group G , and for their classification of spherical 3-manifolds, Hopf, Threlfall and Seifert determined all finite subgroups of $SO(4)$ that can act freely on S^3 . (See also Milnor [67].)

Theorem 12 (Hopf [42], Threlfall and Seifert ([106], [107])) *Any finite subgroup of $SO(4)$ that has a free action on S^3 is either a cyclic group \mathbb{Z}_n , one of*

Table 3: Groups with fixed point free orthogonal action on S^3 .

$D_n^* = \{x, y \mid x^2 = (xy)^2 = y^n\}$, binary dihedral group of order $4n$
$T^* = \{x, y \mid x^2 = (xy)^3 = y^3, x^4 = 1\}$, binary tetrahedral group of order 24
$O^* = \{x, y \mid x^2 = (xy)^3 = y^4, x^4 = 1\}$, binary octahedral group of order 48
$I^* = \{x, y \mid x^2 = (xy)^3 = y^5, x^4 = 1\}$, binary icosahedral group of order 120
$D'_{2^k(2n+1)} = \{x, y \mid x^{2^k} = 1, y^{2n+1} = 1, xyx^{-1} = y^{-1}\}$, where $k \geq 2, n \geq 1$, of order $2^k(2n+1)$
$T'_{8 \cdot 3^k} = \{x, y, z \mid x^2 = (xy)^2 = y^2, zxz^{-1} = y, zyz^{-1} = xy, z^{3^k} = 1\}$, where $k \geq 1$, of order $8 \cdot 3^k$

the groups D_n^* , T^* , O^* , I^* , $D'_{2^k(2n+1)}$, or $T'_{8 \cdot 3^k}$, given in Table 3, or a direct product of any of these groups with a cyclic group of relatively prime order.

Spherical 3-manifolds M are Seifert manifolds which have Euler number $e(M) \neq 0$ and base orbifold X of positive Euler characteristic $\chi(X) > 0$. In particular, they are orientable with orientable orbit surface S^2 or with nonorientable orbit surface $\mathbb{R}\mathbf{P}^2$. According to the analysis of the previous section, fibered spherical 3-manifolds with orbit surface S^2 or $\mathbb{R}\mathbf{P}^2$ can have at most three respectively one exceptional fibers. A complete list of the corresponding spaces with all their possible fiberings is given in Table 4. The spaces themselves are discussed below.

Table 4: Spherical Seifert manifolds.

Manifold	Seifert Fibrations	Fundamental Group
S^3	$\{Oo, 0 \mid 1\}, \{Oo, 0 \mid -1\},$ $\{Oo, 0 \mid 0; (\alpha, 1)\},$ $\{Oo, 0 \mid -1; (\alpha, \alpha - 1)\},$ $\{Oo, 0 \mid b; (\alpha_1, \beta_1), (\alpha_2, \beta_2)\}$ with $(\alpha_1, \alpha_2) = 1$ and $ b\alpha_1\alpha_2 + \alpha_1\beta_2 + \alpha_2\beta_1 = 1$	0
$L(b, 1)$	$\{Oo, 0 \mid b\}, b > 1$	$\mathbb{Z}_{ b }$
$L(b\alpha + \beta, \alpha')$	$\{Oo, 0 \mid b; (\alpha, \beta)\}$ with $ b\alpha + \beta > 1$ and $\alpha' \equiv \alpha \pmod{b\alpha + \beta}$ with $0 < \alpha' < b\alpha + \beta$	$\mathbb{Z}_{ b\alpha + \beta }$
$L(b\alpha_1\alpha_2 + \alpha_1\beta_2 + \alpha_2\beta_1, m\alpha_2 - n\beta_2)$	$\{Oo, 0 \mid b; (\alpha_1, \beta_1), (\alpha_2, \beta_2)\}$ with $ b\alpha_1\alpha_2 + \alpha_1\beta_2 + \alpha_2\beta_1 > 1$ and $m\alpha_1 - n(b\alpha_1 + \beta_1) = 1$	$\mathbb{Z}_{ b\alpha_1\alpha_2 + \alpha_1\beta_2 + \alpha_2\beta_1 }$
$P(r)$	$\{Oo, 0 \mid -1; (2, 1), (2, 1), (r, 1)\}$	D_r^*
generalized prism space	$\{Oo, 0 \mid b; (2, 1), (2, 1), (\alpha_3, \beta_3)\}$ $\{OnI, 1 \mid b; (\alpha_1, \beta_1)\}$ with $ b\alpha_1 + \beta_1 \neq 0$	$\mathbb{Z}_{ (b+1)\alpha_3 + \beta_3 } \times D_{\alpha_3}^*$ if $((b+1)\alpha_3 + \beta_3, 2\alpha_3) = 1,$ $\mathbb{Z}_{ m } \times D'_{2^{k+2}\alpha_3}$ for $(b+1)\alpha_3 + \beta_3 = 2^k m$ with $k \geq 1$ and $(m, 2) = 1,$ $\mathbb{Z}_{\alpha_1} \times D_{ b\alpha_1 + \beta_1 }^*$ if α_1 is odd, $\mathbb{Z}_{\alpha'_1} \times D'_{2^{k+2} b\alpha_1 + \beta_1 }$ for $\alpha_1 = 2^k \alpha'_1$ with $k \geq 1$ and $(\alpha'_1, 2) = 1$
S^3/T^*	$\{Oo, 0 \mid -1; (2, 1), (3, 1), (3, 1)\}$	T^*

Table 4: Spherical Seifert manifolds.

Manifold	Seifert Fibrations	Fundamental Group
generalized octahedral space	$\{Oo, 0 \mid b; (2, 1), (3, \beta_2), (3, \beta_3)\}$	$\mathbb{Z}_{ 6b+3+2\beta_2+2\beta_3 } \times T^*$ if $(6b + 3 + 2\beta_2 + 2\beta_3, 12) = 1$, $\mathbb{Z}_{ m } \times T'_{8, 3^{k+1}}$ for $6b + 3 + 2\beta_2 + 2\beta_3 = 3^k m$ with $k \geq 1$ and $(m, 12) = 1$
S^3/O^*	$\{Oo, 0 \mid -1; (2, 1), (3, 1), (4, 1)\}$	O^*
generalized truncated cube space	$\{Oo, 0 \mid b; (2, 1), (3, \beta_2), (4, \beta_3)\}$	$\mathbb{Z}_{ 12b+6+4\beta_2+3\beta_3 } \times O^*$
$S^3/I^* = \Sigma(2, 3, 5)$	$\{Oo, 0 \mid -1; (2, 1), (3, 1), (5, 1)\}$	I^*
generalized spherical dodecahedral space	$\{Oo, 0 \mid b; (2, 1), (3, \beta_2), (5, \beta_3)\}$	$\mathbb{Z}_{ 30b+15+10\beta_2+6\beta_3 } \times I^*$

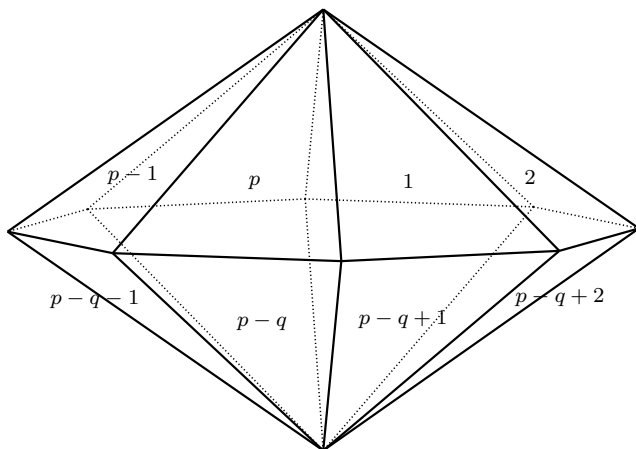

Figure 10: The lens space $L(p, q)$.

Fibered spherical 3-manifolds over S^2 with $r \leq 2$ exceptional fibers are either the sphere S^3 or a lens space $L(p, q)$. The *lens space* $L(p, q)$ of Tietze [112] is defined as a solid lens with p slices where top triangles are identified with bottom triangles under a twist of $2\pi(q/p)$ as depicted in Figure 10. Note that $L(2, 1)$ is the real projective space $\mathbb{R}\mathbf{P}^3$.

The homeomorphism classification of lens spaces is subtle. A lens space $L(p, q)$ has fundamental group \mathbb{Z}_p . However, two lens spaces $L(p, q)$ and $L(p, q')$ with different q and q' need not be homeomorphic, not even homotopy equivalent.

Theorem 13 (Whitehead [119]) $L(p, q) \simeq L(p, q')$ if and only if $qq' \equiv \pm n^2 \pmod{p}$ for some integer n .

For example, $L(5, 1)$ and $L(5, 2)$ are not homotopy equivalent, although they have the same fundamental group (and the same homology groups).

Theorem 14 (Reidemeister [91], Brody [15]) $L(p, q) \cong L(p, q')$ if and only if either $q' \equiv \pm q \pmod{p}$ or $qq' \equiv \pm 1 \pmod{p}$.

As a consequence, for example, the lens spaces $L(7, 1)$ and $L(7, 2)$ are homotopy equivalent but not homeomorphic.

Apart from lens spaces, two spherical 3-manifolds are homeomorphic if and only if they have the same fundamental group.

Triangulations of lens spaces $L(p, q)$ with few simplices were constructed by Brehm and Światkowski [11]. They also gave a series of $D_{2(p+2)}$ -symmetric triangulations $S_{2(p+2)}$ of $L(p, 1)$ on $2p + 7$ vertices. We applied bistellar flips to some of these examples. The f -vectors of the resulting small triangulations are given in Table 5. For small triangulations of other lens spaces see [10].

Table 5: Smallest known triangulations of lens spaces $L(p, 1)$.

Manifold	f -Vector
$\mathbb{R}\mathbf{P}^3 = L(2, 1)$	(11,51,80,40)
$L(3, 1)$	(12,66,108,54)
$L(4, 1)$	(14,84,140,70)
$L(5, 1)$	(15,97,164,82)
$L(6, 1)$	(16,110,188,94)
$L(7, 1)$	(17,123,212,106)
$L(8, 1)$	(18,135,234,117)
$L(9, 1)$	(18,144,252,126)
$L(10, 1)$	(19,156,274,137)

In the case of fibered spherical 3-manifolds with three exceptional fibers (α_1, β_1) , (α_2, β_2) , and (α_3, β_3) it follows from the preceding section that $\frac{1}{\alpha_1} + \frac{1}{\alpha_2} + \frac{1}{\alpha_3} > 1$, which is only possible for the platonic triples $(2, 2, \alpha_3)$, $(2, 3, 3)$, $(2, 3, 4)$, and $(2, 3, 5)$.

The Seifert manifolds $\{Oo, 0|-1; (2, 1), (2, 1), (r, 1)\}$ are called *prism spaces* and are denoted by $P(r)$. Geometrically, $P(r)$ can be obtained from a prism over a regular $2r$ -gon by identifying the top and the bottom side under a twist of π/r . Opposite square side faces are identified after a twist of $\pi/2$; see Figures 11 and 12.

For triangulating the prism spaces, we proceed similar to [7]. We first triangulate the boundary of the solid prism by introducing a midpoint for every side face and by subdividing every edge with two additional vertices. Under the identification, the original $4r$ vertices of the prism are mapped to r vertices $(1, \dots, r$ in Figures 11 and 12). In order to avoid identifications of interior edges, these vertices are cut off by placing a new vertex just below them. Then we put an upright bipyramid over a $2r$ -gon into the interior of the prism (with a vertex of the $2r$ -gon of the bipyramid corresponding to every vertical side face of the prism). We triangulate the space between the bipyramid and the prism (with cut off vertices $1, \dots, r$) consistently as described in [7]. The bipyramid itself is triangulated by connecting its top with its bottom vertex with an edge and then slicing the bipyramid around this edge into tetrahedra.

Theorem 15 *There is a series $P_{12r+3}(r)$ of \mathbb{Z}_{2r} -invariant triangulations of the prism spaces $P(r)$ with $f(P_{12r+3}(r)) = (12r + 3, 84r + 3, 144r, 72r)$.*

The prism spaces $P(r)$ have homology groups

$$H_*(P(r)) = \begin{cases} (\mathbb{Z}, \mathbb{Z}_2^2, 0, \mathbb{Z}), & r \text{ even,} \\ (\mathbb{Z}, \mathbb{Z}_4, 0, \mathbb{Z}), & r \text{ odd,} \end{cases}$$

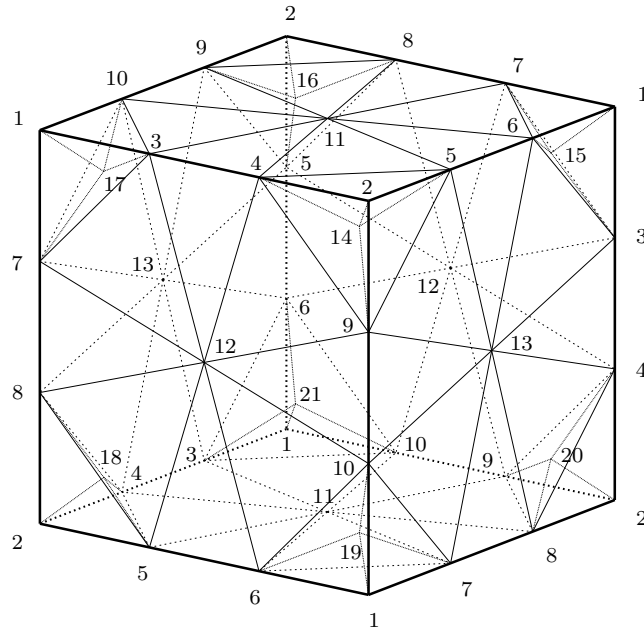

Figure 11: The cube or prism space $P(2)$.

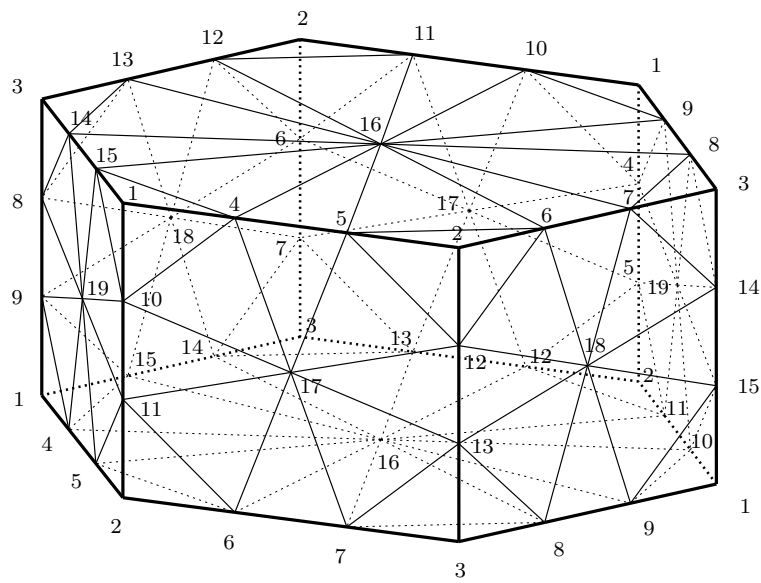

Figure 12: The prism space $P(3)$.

Table 6: Smallest known triangulations of prism spaces $P(r)$.

Manifold	f -Vector
$P(2) = S^3/Q$	(15,90,150,75)
$P(3)$	(15,97,164,82)
$P(4)$	(15,104,178,89)
$P(5)$	(17,123,212,106)
$P(6)$	(18,135,234,117)
$P(7)$	(19,148,258,129)
$P(8)$	(19,156,274,137)
$P(9)$	(20,169,298,149)
$P(10)$	(21,182,322,161)

and fundamental group D_r^* . They arise as quotients S^3/D_r^* of the Lie group S^3 with respect to left/right multiplication of the finite subgroup D_r^* of S^3 .

From the series $P_{12r+3}(r)$ we obtained much smaller triangulations via bistellar flips; see Table 6.

Besides the prism spaces $\{Oo, 0 \mid -1; (2, 1), (2, 1), (r, 1)\}$, there are further spherical 3-manifolds corresponding to the platonic triple $(2, 2, \alpha_3)$, namely the *generalized prism spaces* $\{Oo, 0 \mid b; (2, 1), (2, 1), (\alpha_3, \beta_3)\}$. They are the only spherical 3-manifolds that allow a fibration $\{OnI, 1 \mid b; (\alpha_1, \beta_1)\}$ over the nonorientable orbit surface \mathbb{RP}^2 .

Associated with the platonic triple $(2, 3, 5)$ are the spherical dodecahedron space S^3/I^* with Seifert invariants $\{Oo, 0 \mid -1; (2, 1), (3, 1), (5, 1)\}$ and the *generalized spherical dodecahedral spaces* $\{Oo, 0 \mid b; (2, 1), (3, \beta_2), (5, \beta_3)\}$ (see Table 4 for the fundamental groups of these spaces).

The spherical dodecahedral space, i.e., the Poincaré homology 3-sphere, is the only fibered homology 3-sphere with finite fundamental group [99]. It coincides with the Brieskorn homology sphere $\Sigma(2, 3, 5)$; see Section 11. Triangulations of the Poincaré homology 3-sphere, in particular, a triangulation Σ_{16}^3 with 16 vertices, are given in [7]; see also [8]. Triangulations of the generalized spherical dodecahedral spaces are constructed in [10].

The spherical spaces that are obtained for the platonic triple $(2, 3, 3)$ are the octahedral space S^3/T^* , with the binary tetrahedral group T^* of order 24 as fundamental group, and the generalized octahedral spaces.

The octahedral space can be triangulated as follows. We begin with a solid octahedron and identify opposite triangles by a twist of $\pi/3$. We subdivide every edge with two vertices and every triangle by inserting a center vertex; see Figure 13. Under the identification, all original vertices are mapped to the vertex 1 and are cut off by placing new vertices below them. After the

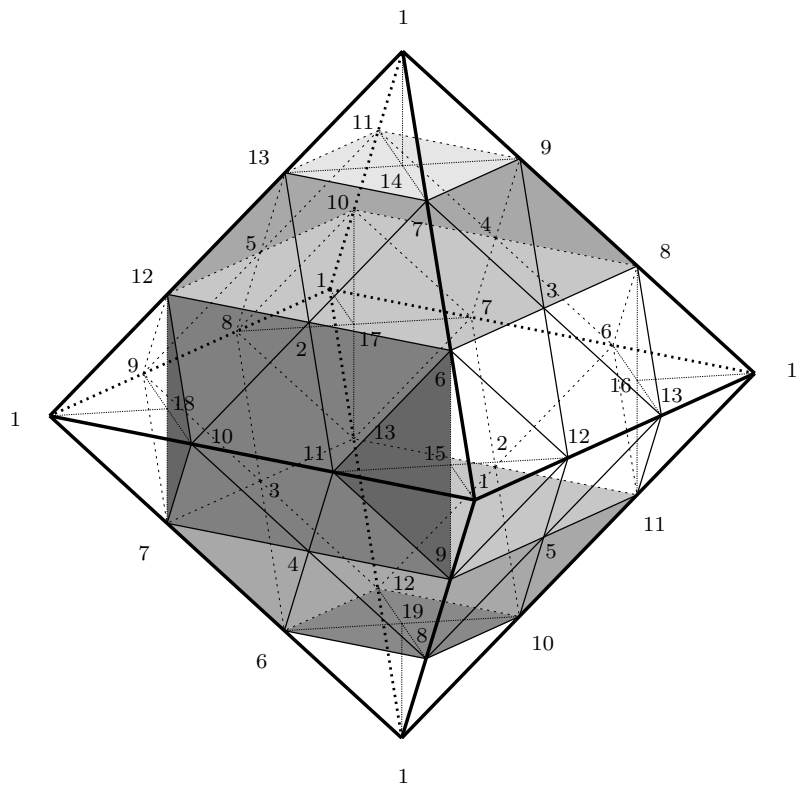

Figure 13: Octahedral space.

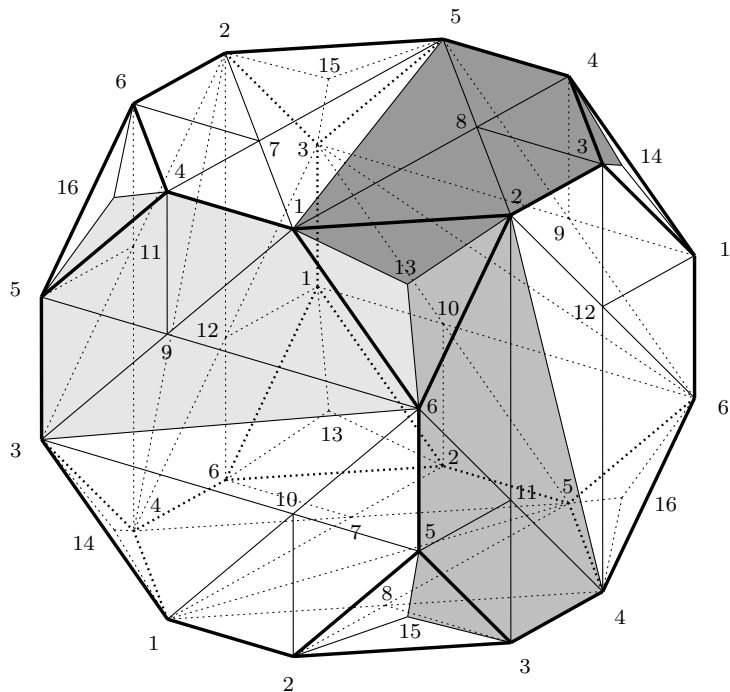

Figure 14: Truncated cube space.

cutting, the boundary (with identifications) of the truncated octahedron is split into two polar and four equatorial regions as depicted in Figure 13. We place another octahedron in the center of the truncated octahedron, with one equatorial respectively polar vertex of the inner octahedron corresponding to every equatorial respectively polar region of the outer truncated octahedron. The space between the outer truncated and the inner octahedron is triangulated consistently. The inner octahedron is triangulated by introducing an edge from top to bottom.

The remaining platonic triple $(2, 3, 4)$ yields the truncated cube space S^3/O^* and the generalized truncated cube spaces; see Table 4.

For a triangulation of S^3/O^* we triangulate first the boundary of a truncated cube with identified opposite octagons and triangles as in Figure 14. Then we split the (identified) boundary into 12 congruent pieces (three of them are shaded in Figure 14). To every of the 12 pieces we associate a vertex of an icosahedron that we place into the interior of the truncated cube and then triangulate the space consistently.

Once again, by applying bistellar flips to the above triangulations of the spherical octahedron and the truncated cube space, we obtain small triangulations of these spaces. For the f -vectors of these triangulations see Table 7.

Table 7: Smallest known triangulations of the spherical octahedral, truncated cube and dodecahedral space.

Manifold	Homology	f -Vector
S^3/T^*	$(\mathbb{Z}, \mathbb{Z}_3, 0, \mathbb{Z})$	(15,102,174,87)
S^3/O^*	$(\mathbb{Z}, \mathbb{Z}_2, 0, \mathbb{Z})$	(16,109,186,93)
$\Sigma^3 = S^3/I^*$	$(\mathbb{Z}, 0, 0, \mathbb{Z})$	(16,106,180,90)

The full triangulations can be found online at [62].

Theorem 16 *The spherical octahedron and the truncated cube space can be triangulated with 15 respectively 16 vertices.*

Conjecture 17 *The triangulations with 15 respectively 16 vertices of the spherical octahedron and the truncated cube space are vertex-minimal.*

Now that we have seen various examples of spherical 3-manifolds, we return to Thurston’s Geometrization Conjecture and its implications for 3-manifolds with finite fundamental groups.

Conjecture 18 (Thurston’s Elliptization Conjecture [108]) *Every (closed) 3-manifold with finite fundamental group can be modeled on the spherical geometry $(S^3, SO(4))$.*

If a 3-manifold has finite fundamental group, then its universal cover is a homotopy sphere. Thus, in particular, Thurston’s Elliptization Conjecture comprises the Poincaré Conjecture. (A proof of the Elliptization Conjecture has recently been announced by Perelman [85].)

Thurston’s conjecture also states that every free action of a finite group on S^3 is conjugate to an orthogonal action, and, at least for this part of the conjecture, partial results have been known for a while. Milnor [67] determined a list of finite groups which might act freely on S^3 . This list was reduced by Lee [57], and (based on the Smale Conjecture that $\text{Diff}(S^3) = O(4)$, which later was proved by Hatcher [32]) Thomas [105] showed that, in fact, only the subgroups of $SO(4)$ classified by Hopf and Threlfall and Seifert need to be considered. For a number of these groups it has been shown that if they act fixed point freely on S^3 , then this action is conjugate to an orthogonal action. See Myers [75], Scott [97], and Maher and Rubinstein [65] for a discussion and for further references.

5 Flat Spaces

Discrete groups of isometries of the Euclidean space E^3 were first studied in the context of crystallography in the late 19th century (see the references in [120]).

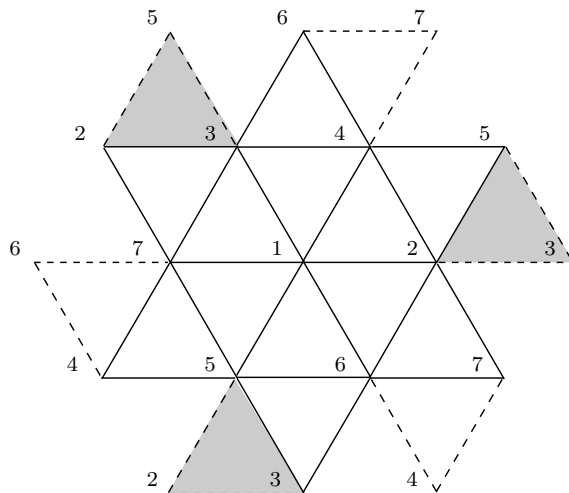

Figure 15: Möbius torus.

In 1911, Bieberbach ([4], [5]) presented a comprehensive structure theory for crystallographic groups. Based on the results by Bieberbach, Nowacki [79] gave a homeomorphism classification and Hantzsche and Wendt [31] worked out an affine classification of Euclidean space forms. An isometric classification of flat 3-manifolds was later obtained by Wolf [120, Ch. 3].

Theorem 19 (Nowacki [79], Hantzsche and Wendt [31], and Wolf [120]) There are exactly 6 orientable flat 3-manifolds, $\mathcal{G}_1, \dots, \mathcal{G}_6$, and 4 non-orientable ones, $\mathcal{B}_1, \dots, \mathcal{B}_4$.

Nine of the ten flat spaces can be obtained as torus or Klein bottle bundles over S^1 . The direct products $T^2 \times S^1 = T^3$ and $K \times S^1$ yield the manifolds \mathcal{G}_1 and \mathcal{B}_1 , respectively. The other seven bundles are twisted products. All these spaces can easily be triangulated.

Triangulations of orientable flat spaces. The unique minimal triangulation of the 2-torus T^2 is Möbius' torus [72] with 7 vertices and is depicted in Figure 15.

The direct product triangulation of the Möbius torus with S^1 triangulated as an empty triangle has $7 \cdot 3 = 21$ vertices. A 15-vertex triangulation of T^3 was first found by Kühnel and Lassmann [55], and it is conjectured that 15 vertices are minimal for a triangulation of the 3-dimensional torus.

Möbius' torus has the affine group $AGL(1, 7)$ as vertex-transitive combinatorial automorphism group, and every group element of $AGL(1, 7)$ can be used to construct a corresponding twisted product triangulation of the 2-torus over S^1 by applying this group element to one boundary component of the product

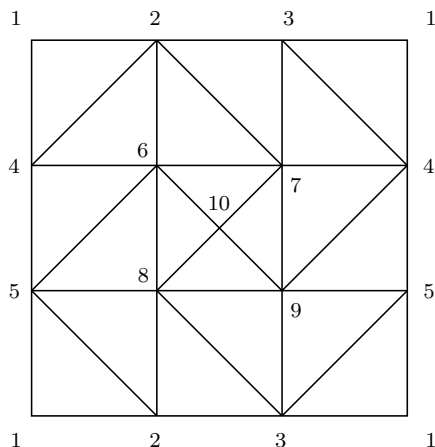

Figure 16: Torus with rotation by $\pi/2$.

triangulation of $T^2 \times I$ before gluing together the two boundary 2-tori. Gluing under the permutations $(2, 4, 3, 7, 5, 6)$, $(2, 3, 5)(4, 7, 6)$, and $(2, 7)(3, 6)(4, 5)$ of the vertices of the Möbius torus in Figure 15, which induce rotations by $2\pi/6$, $2\pi/3$, and $2\pi/2$, yields the flat spaces \mathcal{G}_5 , \mathcal{G}_3 , and \mathcal{G}_2 , respectively. All other twisted products of the Möbius torus over S^1 are homeomorphic to one of these spaces (or to $T^3 = \mathcal{G}_1$ under the trivial identification).

There is one further orientable flat T^2 -bundle over S^1 , the manifold \mathcal{G}_4 , which can be triangulated by starting with the 10-vertex triangulation of the 2-torus in Figure 16 and then identifying the two boundary components of the corresponding twisted product triangulation over I under a twist of $2\pi/4$. In fact, there is no smaller twisted product triangulation of \mathcal{G}_4 . There are 7 combinatorially distinct triangulations of T^2 with 8 vertices [20] and 112 triangulations with 9 vertices [63], but none of these admits a (combinatorial) rotation by $\pi/2$.

Theorem 20 *The orientable flat spaces \mathcal{G}_2 , \mathcal{G}_3 , \mathcal{G}_4 , and \mathcal{G}_5 have minimal twisted product triangulations with 21, 21, 30, and 21 vertices, respectively.*

The remaining orientable flat 3-manifold \mathcal{G}_6 is not a torus bundle over S^1 , but can be constructed by gluing together two solid cubes along their boundary squares in a very symmetric way, as described in [111, p. 126]. In Figure 17, the two cubes are shown with the respective identifications. For a triangulation of this space, the two cubes are each split into eight cubes, which then are triangulated by their barycentric subdivision. The resulting triangulation of \mathcal{G}_6 has f -vector $f = (128, 896, 1536, 768)$.

Since flat 3-manifolds are Seifert manifolds, we can alternatively obtain triangulations of them as described in [10]. The Euler number $e(M)$ of an Euclidean 3-manifold M and the Euler characteristic of the respective base

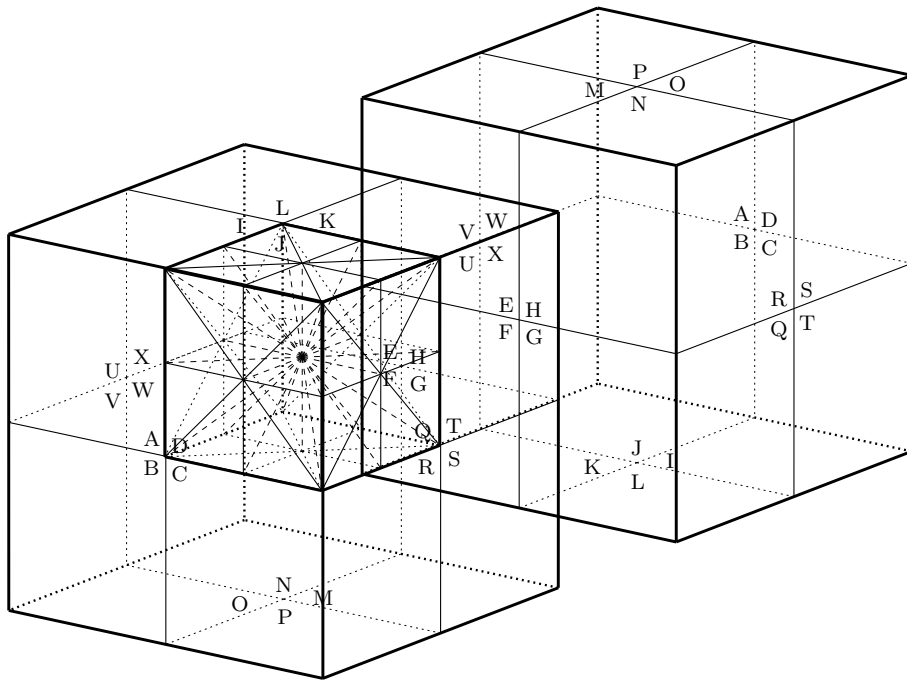

Figure 17: The flat space \mathcal{G}_6 .

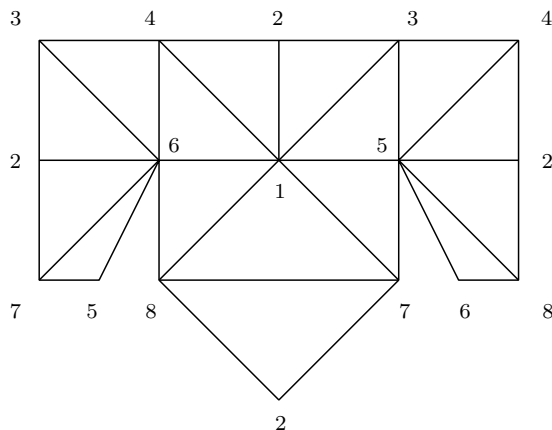

Figure 18: 8-vertex Klein bottle ${}^2\mathcal{8}_{20}$.

orbifold are both zero. It is then an easy exercise to compute the sets of Seifert invariants, which are possible for the flat spaces.

By applying bistellar flips to the above triangulations we get small triangulations.

Theorem 21 *The orientable flat 3-manifolds $\mathcal{G}_1, \dots, \mathcal{G}_6$ can be triangulated with 15, 17, 17, 16, 16, and 17 vertices, respectively.*

The homology groups, the Seifert fibrations, and the smallest known f -vectors of the spaces $\mathcal{G}_1, \dots, \mathcal{G}_6$ and of the spaces $\mathcal{B}_1, \dots, \mathcal{B}_4$ are listed in Table 9. Note that the ten flat spaces have pairwise distinct homology. The spaces $\mathcal{G}_2, \mathcal{B}_1, \mathcal{B}_2,$ and \mathcal{B}_4 have two different Seifert fibrations, respectively, while the other spaces each have a unique Seifert fibration.

Triangulations of non-orientable flat spaces. All four non-orientable flat 3-manifolds $\mathcal{B}_1, \dots, \mathcal{B}_4$ are Klein bottle bundles over S^1 . (The space \mathcal{B}_2 can also be obtained as a non-orientable torus bundle over S^1 .) The Klein bottle K can be minimally be triangulated with 8 vertices. There are altogether six 8-vertex triangulations of K ([17], [20]), one of which is the example ${}^2\mathcal{8}_{20}$ of [63], shown in Figure 18. It can be read off directly from the figure that the example is a triangulation of the Klein bottle, since the boundary consists of $2 + 2$ arcs $2-7-5-6-8-2$, $2-7-5-6-8-2$, $2-4-3-2$, and $2-4-3-2$, which are just the arcs of the fundamental polygon (see [103, Ch. 1]) of the Klein bottle.

The automorphism group of ${}^2\mathcal{8}_{20}$ is isomorphic to the dihedral group D_4 and is rich enough for constructing (twisted) product triangulations of all four non-orientable flat 3-manifolds from the triangulation ${}^2\mathcal{8}_{20}$. In Table 8 we list the group elements and the corresponding flat spaces.

Theorem 22 *The non-orientable flat spaces $\mathcal{B}_1, \mathcal{B}_2, \mathcal{B}_3,$ and \mathcal{B}_4 have minimal (twisted) product triangulations with 24 vertices.*

Table 8: Twisted product spaces of the Klein bottle ${}^2\mathcal{K}_{20}$.

Manifold	Gluing Transformations
\mathcal{B}_1	$()$, $(1, 2)(5, 6)$
\mathcal{B}_2	$(1, 5, 2, 6)(3, 8)(4, 7)$, $(1, 6, 2, 5)(3, 8)(4, 7)$
\mathcal{B}_3	$(1, 2)(3, 4)(7, 8)$, $(3, 4)(5, 6)(7, 8)$
\mathcal{B}_4	$(1, 5)(2, 6)(3, 7)(4, 8)$, $(1, 6)(2, 5)(3, 7)(4, 8)$

Taking these triangulations as starting triangulations, we obtained smaller triangulations via bistellar flips.

Theorem 23 *The non-orientable flat 3-manifolds $\mathcal{B}_1, \dots, \mathcal{B}_4$ can be triangulated with 17, 16, 17, and 17 vertices, respectively.*

In this section we have chosen to construct triangulations of the flat spaces via products and twisted products (except for \mathcal{G}_6). This approach has the advantage that the resulting triangulations are rather small and simple to produce. Identifying the faces of a cube, of a hexagonal prism, or of a rhombic dodecahedron, however, gives a more geometric way for obtaining flat spaces. See Cipra [18] for illustrations of the identifications.

Table 9: Smallest known triangulations of flat spaces.

Manifold	Seifert Fibrations	Homology	f -Vector
$\mathcal{G}_1 = T^3$	$\{Oo, 1 \mid 0\}$	$(\mathbb{Z}, \mathbb{Z}^3, \mathbb{Z}^3, \mathbb{Z})$	(15,105,180,90)
\mathcal{G}_2	$\{Oo, 0 \mid -2; (2, 1), (2, 1), (2, 1), (2, 1)\},$ $\{On, 2 \mid 0\}$	$(\mathbb{Z}, \mathbb{Z} \oplus \mathbb{Z}_2^2, \mathbb{Z}, \mathbb{Z})$	(17,118,202,101)
\mathcal{G}_3	$\{Oo, 0 \mid -1; (3, 1), (3, 1), (3, 1)\}$	$(\mathbb{Z}, \mathbb{Z} \oplus \mathbb{Z}_3, \mathbb{Z}, \mathbb{Z})$	(17,117,200,100)
\mathcal{G}_4	$\{Oo, 0 \mid -1; (2, 1), (4, 1), (4, 1)\}$	$(\mathbb{Z}, \mathbb{Z} \oplus \mathbb{Z}_2, \mathbb{Z}, \mathbb{Z})$	(16,115,198,99)
\mathcal{G}_5	$\{Oo, 0 \mid -1; (2, 1), (3, 1), (6, 1)\}$	$(\mathbb{Z}, \mathbb{Z}, \mathbb{Z}, \mathbb{Z})$	(16,112,192,96)
\mathcal{G}_6	$\{On, 1 \mid -1; (2, 1), (2, 1)\}$	$(\mathbb{Z}, \mathbb{Z}_4^2, 0, \mathbb{Z})$	(17,124,214,107)
$\mathcal{B}_1 = K \times S^1$	$\{NnI, 2 \mid 0\}, \{No, 1 \mid 0\}$	$(\mathbb{Z}, \mathbb{Z}^2 \oplus \mathbb{Z}_2, \mathbb{Z} \oplus \mathbb{Z}_2, 0)$	(17,118,202,101)
\mathcal{B}_2	$\{NnI, 2 \mid 1\}, \{No, 1 \mid 1\}$	$(\mathbb{Z}, \mathbb{Z}^2, \mathbb{Z} \oplus \mathbb{Z}_2, 0)$	(16,110,188,94)
\mathcal{B}_3	$\{NnII, 2 \mid 0\}$	$(\mathbb{Z}, \mathbb{Z} \oplus \mathbb{Z}_2^2, \mathbb{Z}_2, 0)$	(17,119,204,102)
\mathcal{B}_4	$\{NnII, 2 \mid 1\}, \{NnI, 1 \mid 0; (2, 1), (2, 1)\}$	$(\mathbb{Z}, \mathbb{Z} \oplus \mathbb{Z}_4, \mathbb{Z}_2, 0)$	(17,117,200,100)

Table 10: Seifert fibrations of Nil-spaces.

Seifert Fibration	Homology
$\{Oo, 0 \mid b; (2, 1), (3, 1), (6, 1)\}, \quad b \neq -1$	$(\mathbb{Z}, \mathbb{Z}_{36 b+1 }, 0, \mathbb{Z})$
$\{Oo, 0 \mid b; (2, 1), (3, 1), (6, 5)\}$	$(\mathbb{Z}, \mathbb{Z}_{24+36 b+1 }, 0, \mathbb{Z}), \quad b \geq -1,$ $(\mathbb{Z}, \mathbb{Z}_{12+36 b+2 }, 0, \mathbb{Z}), \quad b \leq -2$
$\{Oo, 0 \mid b; (2, 1), (4, 1), (4, 1)\}, \quad b \neq -1$	$(\mathbb{Z}, \mathbb{Z}_2 \oplus \mathbb{Z}_{16 b+1 }, 0, \mathbb{Z})$
$\{Oo, 0 \mid b; (2, 1), (4, 1), (4, 3)\}$	$(\mathbb{Z}, \mathbb{Z}_2 \oplus \mathbb{Z}_{16 b+\frac{3}{2} }, 0, \mathbb{Z})$
$\{Oo, 0 \mid b; (3, 1), (3, 1), (3, 1)\}, \quad b \neq -1$	$(\mathbb{Z}, \mathbb{Z}_3 \oplus \mathbb{Z}_{9 b+1 }, 0, \mathbb{Z})$
$\{Oo, 0 \mid b; (3, 1), (3, 1), (3, 2)\}$	$(\mathbb{Z}, \mathbb{Z}_3 \oplus \mathbb{Z}_{3+9 b+1 }, 0, \mathbb{Z}), \quad b \geq -1,$ $(\mathbb{Z}, \mathbb{Z}_3 \oplus \mathbb{Z}_{6+9 b+2 }, 0, \mathbb{Z}), \quad b \leq -2$
$\{Oo, 0 \mid b; (2, 1), (2, 1), (2, 1), (2, 1)\}, \quad b \neq -2$	$(\mathbb{Z}, \mathbb{Z}_2^2 \oplus \mathbb{Z}_{4 b+2 }, 0, \mathbb{Z})$
$\{Oo, 1 \mid b\}, \quad b \neq 0$	$(\mathbb{Z}, \mathbb{Z}^2 \oplus \mathbb{Z}_b, \mathbb{Z}^2, \mathbb{Z})$
$\{On, 1 \mid b; (2, 1), (2, 1)\}, \quad b \neq -1$	$(\mathbb{Z}, \mathbb{Z}_4^2, 0, \mathbb{Z})$
$\{On, 2 \mid b\}, \quad b \neq 0$	$(\mathbb{Z}, \mathbb{Z} \oplus \mathbb{Z}_2^2, \mathbb{Z}, \mathbb{Z})$ if b is even, $(\mathbb{Z}, \mathbb{Z} \oplus \mathbb{Z}_4, \mathbb{Z}, \mathbb{Z})$ if b is odd

6 Nil-Spaces

The Heisenberg group Nil of upper triangular matrices $A \in GL(3, \mathbb{R})$ of the form

$$A = \begin{pmatrix} 1 & u & w \\ 0 & 1 & v \\ 0 & 0 & 1 \end{pmatrix}$$

is a nilpotent Lie group. The Nil-spaces modeled on the geometry Nil are orientable and can be Seifert fibered with Euler number $e \neq 0$ and base orbifold of Euler characteristic $\chi = 0$. The possible sets of Seifert invariants are listed in Table 10.

The Nil-spaces $M_b = \{Oo, 1 \mid b\}$ and $M'_b = \{On, 2 \mid b\}$ with $b \neq 0$ are examples of \mathbb{T}^2 -bundles over S^1 . The manifolds M_b also arise as quotients of Nil with respect to the discrete subgroup of matrices N_b of Nil for which $u, v, w \in b\mathbb{Z}$; see [81, p. 124] and [82].

In fact, \mathbb{T}^2 -bundles over S^1 are either flat or belong to the geometries Nil or Sol, depending only on the gluing map; see [97] for details.

7 $(H^2 \times \mathbb{R})$ -Spaces

Products of hyperbolic surfaces with S^1 are natural examples of $(H^2 \times \mathbb{R})$ -spaces. Also the mapping tori of isometries of hyperbolic surfaces are $(H^2 \times \mathbb{R})$ -spaces.

Table 11: Smallest known triangulations of some $(H^2 \times \mathbb{R})$ -spaces.

Manifold	f -Vector
$M_{(+,2)}^2 \times S^1$	(20,171,302,151)
$M_{(+,3)}^2 \times S^1$	(22,211,378,189)
$M_{(+,4)}^2 \times S^1$	(26,269,486,243)
$M_{(+,5)}^2 \times S^1$	(28,312,568,284)
$M_{(-,3)}^2 \times S^1$	(19,146,254,127)
$M_{(-,4)}^2 \times S^1$	(20,168,296,148)
$M_{(-,5)}^2 \times S^1$	(21,192,342,171)

For triangulating the product spaces we can start with any triangulation of an orientable surface $M_{(+,g)}^2$ of genus $g \geq 2$ or a non-orientable surface $M_{(-,g)}^2$ of genus $g \geq 3$ and then form the product triangulation. Vertex-minimal triangulations of surfaces were mainly obtained by Ringel [92] and Jungerman and Ringel [47]; see also the book by Ringel [93]. The f -vectors of small triangulations of some products can be found in Table 11. The product spaces have homology $H_*(M_{(+,g)}^2 \times S^1) = (\mathbb{Z}, \mathbb{Z}^{2g+1}, \mathbb{Z}^{2g+1}, \mathbb{Z})$ and $H_*(M_{(-,g)}^2 \times S^1) = (\mathbb{Z}, \mathbb{Z}^g \oplus \mathbb{Z}_2, \mathbb{Z}^{g-1} \oplus \mathbb{Z}_2, 0)$.

An abundance of twisted product triangulations of $(H^2 \times \mathbb{R})$ -spaces can be constructed with the help of combinatorial isomorphisms of triangulated hyperbolic surfaces.

8 $\widetilde{SL}(2, \mathbb{R})$ -Spaces

The last of the six Seifert geometries is $\widetilde{SL}(2, \mathbb{R})$ and is discussed in [97], [111], and [110]. Particularly interesting examples of $\widetilde{SL}(2, \mathbb{R})$ -spaces are the Seifert homology spheres, which, with the exception of the Poincaré sphere with finite fundamental group, all belong to this geometry. See Section 12 for further comments.

9 Sol-Spaces

Manifolds modeled on the geometry Sol are either torus or Klein bottle bundles over S^1 or are composed of two twisted I -bundles over the torus or the Klein bottle. This classification follows from work of Hempel and Jaco [35]; see also [97]. Triangulations of torus bundles are discussed in [64].

10 Hyperbolic Spaces

According to Thurston [108], “most” of the prime 3-manifolds are hyperbolic. In fact, if $L \subset M^3$ is a link in a three-manifold M^3 such that $M^3 \setminus L$ has a hyperbolic structure, then almost every manifold that results from M^3 by Dehn surgery along the link L has a hyperbolic structure.

Hodgson and Weeks [41] gave a census of 11,031 orientable closed hyperbolic 3-manifolds obtained by Dehn filling on the examples of a census of cusped hyperbolic three-manifolds by Hildebrand and Weeks [36]. The Hildebrand-Weeks census comprises 415 cusped hyperbolic three-manifolds obtained from gluing five or fewer ideal hyperbolic tetrahedra, a concept introduced by Thurston ([109], [110, Ch. 4]), and has later been extended to a census of 6075 cusped hyperbolic three-manifolds with up to seven ideal tetrahedra by Callahan, Hildebrand, and Weeks [16].

Hyperbolic 3-manifolds that arise by identifying the faces of a Platonic solid were classified by Everitt [23]. The best known of these examples is the hyperbolic dodecahedral space of Weber and Seifert [118]. This space has homology $(\mathbb{Z}, \mathbb{Z}_5^3, 0, \mathbb{Z})$, and its smallest known triangulation has f -vector $f = (22, 196, 348, 174)$.

11 Complex Hypersurfaces and Varieties

One fruitful and extensively studied way to obtain examples of manifolds is via complex hypersurfaces or varieties. In this section we give some basic facts and examples following Brieskorn ([12], [13]), Hirzebruch ([39], [40]), and Milnor ([69], [70]). (For an introduction into algebraic geometry see Cox, Little, and O’Shea [19].)

For every non-constant complex polynomial $f(z_1, \dots, z_n)$ in n variables the set

$$V_f = \{ z \in \mathbb{C}^n \mid f(z) = 0 \}$$

is called a (*affine*) *complex hypersurface*. Let

$$S_{(\varepsilon, z^*)}^{2n-1} = \{ z \in \mathbb{C}^n \mid |z_1 - z_1^*|^2 + \dots + |z_n - z_n^*|^2 = \varepsilon^2 \}$$

be the sphere of real dimension $2n - 1$ in \mathbb{C}^n with center z^* and small radius ε . (We simply write S^{2n-1} if $\varepsilon = 1$ and z^* is the origin.)

A point $z^* \in \mathbb{C}^n$ is *regular* if not all of the partial derivatives $\partial f / \partial z_j$ vanish at z^* . In this case, the intersection

$$K = V_f \cap S_{(\varepsilon, z^*)}^{2n-1}$$

is a smooth $(2n - 3)$ -manifold diffeomorphic to the standard $(2n - 3)$ -sphere.

If all the partial derivatives $\partial f / \partial z_j$ are zero at $z^* \in \mathbb{C}^n$, then z^* is a *critical point*, and z^* is called *isolated* if there are no other critical points in a small neighborhood of z^* .

A subset $V \subset \mathbb{C}^n$ is a (*affine*) *variety* or a *complex algebraic set* if it arises as an intersection $V = V_{f_1} \cap \dots \cap V_{f_m}$ of complex hypersurfaces corresponding to a collection $\{f_1, \dots, f_m\}$ of polynomial functions on \mathbb{C}^n . A point $z^* \in \mathbb{C}^n$ is *non-singular* or *simple* if the matrix $(\partial f_i / \partial x_j)$ has maximal rank at z^* , and *singular* otherwise.

If V and V' are two algebraic sets in \mathbb{C}^n , then so is their union $V \cup V'$. A non-empty algebraic set V is *irreducible* if it cannot be expressed as the union of two proper algebraic subsets.

Theorem 24 ([69, 2.9]) *For every isolated singular point z^* of an irreducible variety V and sufficiently small ε , the set $K = V \cap S_{(\varepsilon, z^*)}^{2n-1}$ is a smooth $(2n-3)$ -manifold (possibly the empty set).*

Brauer [9] considered the neighborhood boundaries K of (isolated) singular points for analyzing polynomials in two complex variables. For example, if $f(z_1, z_2) = z_1^p + z_2^q$, then K is a torus knot of type (p, q) in the 3-sphere $S_{(\varepsilon, 0)}^3$. Higher-dimensional manifolds that arise this way were first studied by Brieskorn [13]. He proved that for even $n \geq 2$ the manifold

$$\Sigma^{2n-3}(2, 2, \dots, 2, 3) = \{ (z_1, \dots, z_n) \in \mathbb{C}^n \mid z_1^2 + \dots + z_{n-1}^2 + z_n^3 = 0 \} \cap S^{2n-1}$$

is homeomorphic to the sphere S^{2n-3} . The result of Brieskorn has the following generalization.

Theorem 25 ([69, 5.2, 8.1]) *If the origin is an isolated critical point of the polynomial $f(z_1, \dots, z_n)$, $n \geq 2$, then the $(2n-3)$ -dimensional manifold $K = f^{-1}(0) \cap S_{(\varepsilon, 0)}^{2n-1}$ is $(n-3)$ -connected. In particular, K is non-empty for $n \geq 2$, connected for $n \geq 3$, and simply connected for $n \geq 4$. Thus, for $n \neq 3$ the manifold K is homeomorphic to the sphere S^{2n-3} if and only if K has the homology of a sphere.*

However, Hirzebruch [40, 11.3] observed that for even $n \geq 4$ and odd $r \equiv \pm 3 \pmod{8}$ the manifold

$$W^{2n-3}(r) = \{ (z_1, \dots, z_n) \in \mathbb{C}^n \mid z_1^2 + \dots + z_{n-1}^2 + z_n^r = 0 \} \cap S^{2n-1}$$

is diffeomorphic to Kervaire's sphere, which is an exotic sphere if r and n are not powers of 2. In particular, for $n = 6$, the 9-dimensional Kervaire sphere $\Sigma(2, 2, 2, 2, 2, 3)$ is exotic [48]. For even $n \geq 4$ and odd $r \equiv \pm 1 \pmod{8}$ the manifold $W^{2n-3}(r)$ is diffeomorphic to the standard $(2n-3)$ -sphere.

The manifold $W^3(3)$ is homeomorphic to the lens space $L(3, 1)$ [38] and coincides with the Brieskorn manifold $M(2, 2, 3)$; see below. Further special cases are: $W^{(2n-3)}(0)$ is diffeomorphic to $S^{n-1} \times S^{n-2}$, $W^{2n-3}(1)$ is diffeomorphic to S^{2n-3} , and $W^{2n-3}(2)$ is the Stiefel manifold $V_{n,2}$; see [40, §6].

Based on Pham's work [87] on hypersurfaces of the form

$$\Xi_a(t) = \{ z \in \mathbb{C}^n \mid z_1^{a_1} + \dots + z_n^{a_n} = t \}, \quad \text{with } t \in \mathbb{C},$$

Brieskorn [12] studied the manifolds

$$\Sigma(a_1, \dots, a_n) = \Xi_a(0) \cap S^{2n-1},$$

where $a = (a_1, \dots, a_n)$ is a collection of integers with $a_i \geq 2$. The space $\Sigma(a_1, \dots, a_n)$ is a topological sphere if and only if $\Xi_a(0)$ is a topological manifold, and for $n \geq 4$ Brieskorn provided a necessary and sufficient condition for this to be the case. In particular, for $m \geq 2$ and $n = 2m + 1$ the manifolds $\Sigma(2, \dots, 2, 3, 6k - 1)$ with $k = 1, \dots, |bP_{4m-1}|$ are $(4m - 1)$ -spheres and represent all $|bP_{4m-1}|$ different differentiable structures in the cyclic group bP_{4m-1} of h -cobordism classes of $(4m - 1)$ -spheres; cf. [49]. Thus, for $m = 2$ and $m = 3$ the spheres $\Sigma(2, 2, 2, 3, 6k - 1)$ and $\Sigma(2, 2, 2, 2, 2, 3, 6k - 1)$ yield all 28 respectively 992 different classes of exotic 7- and exotic 11-spheres.

Let us return to 3-dimensional manifolds. According to Milnor [70], the geometric type of a 3-dimensional Brieskorn manifold $M(p, q, r)$, $p, q, r \geq 2$, which results from the intersection of the complex algebraic Pham-Brieskorn hypersurface $\Xi_{(p,q,r)}(0) = \{z \in \mathbb{C}^3 \mid z_1^p + z_2^q + z_3^r = 0\}$ with the sphere S^5 depends only on the sign of the rational number $\frac{1}{p} + \frac{1}{q} + \frac{1}{r} - 1$.

For $\frac{1}{p} + \frac{1}{q} + \frac{1}{r} > 1$ the 3-manifold $M(p, q, r)$ is spherical and its fundamental group has order $\frac{4}{pqr}(\frac{1}{p} + \frac{1}{q} + \frac{1}{r})^{-2}$. These manifolds were first discussed by Brieskorn [14] and yield the following examples (see also [70] and [114]). $M(2, 2, r)$ are the lens spaces $L(r, 1)$, $M(2, 3, 3)$ is the prism space $P(2)$, $M(2, 3, 4)$ is the octahedral space S^3/T^* , and $M(2, 3, 5)$ is the spherical dodecahedral space. In the case that we allow $r = 0, 1$ for $M(2, 2, r)$, then the resulting manifolds are $M(2, 2, 1) \cong L(1, 1) \cong S^3$ and $M(2, 2, 0) \cong L(0, 1) \cong S^2 \times S^1$; see Hirzebruch [40, 5.7].

For $\frac{1}{p} + \frac{1}{q} + \frac{1}{r} = 1$ Orlik [80] proved that $M(p, q, r)$ belongs to the geometry Nil. In particular, the three possible examples $M(2, 3, 6)$, $M(2, 4, 4)$, and $M(3, 3, 3)$ are just the T^2 -bundles M_1 , M_2 , and M_3 over S^1 from Section 6; see [70].

Finally, if $\frac{1}{p} + \frac{1}{q} + \frac{1}{r} < 1$, then $M(p, q, r)$ is modeled on $\widetilde{SL}(2, \mathbb{R})$. For a detailed account of this case see [70]. Not all Brieskorn manifolds of type $\widetilde{SL}(2, \mathbb{R})$ are distinct: For example, $M(2, 9, 18) \cong M(3, 5, 15)$.

The spherical Brieskorn manifolds yield all spherical 3-manifolds that arise as quotients S^3/G with respect to finite subgroups G of S^3 , except for the truncated cube space S^3/O^* and the prism spaces $P(k)$, $k \geq 3$. However, these manifolds have simple descriptions as complex hypersurfaces (cf., [69, p. 80]). The truncated cube space S^3/O^* is defined by the equation

$$z_1^2 + z_2^3 + z_2 z_3^3 = 0,$$

and the prism spaces $P(k)$ result from the hypersurfaces

$$z_1^2 + z_2^2 z_3 + z_3^{k+1} = 0.$$

A generalization of Milnor's result on Brieskorn manifolds is due to Neumann [76]. Let $(\alpha_1, \dots, \alpha_n)$ be an n -tuple of integers with $\alpha_i \geq 2$ and $A = (a_{ij})_{1 \leq i \leq n-2, 1 \leq j \leq n}$ be a matrix of complex numbers such that every $(n-2) \times (n-2)$ subdeterminant is non-zero. Then the complex algebraic set

$$V_A(\alpha_1, \dots, \alpha_n) = \{z \in \mathbb{C}^n \mid a_{i1}z_1^{\alpha_1} + \dots + a_{in}z_n^{\alpha_n} = 0, \quad i = 1, \dots, n-2\}$$

is called a *Brieskorn complete intersection* or a *generalized Brieskorn variety*, and the manifold $M^3(\alpha_1, \dots, \alpha_n) = V_A(\alpha_1, \dots, \alpha_n) \cap S^{2n-1}$ is a *generalized Brieskorn manifold*. In fact, $M^3(\alpha_1, \dots, \alpha_n)$ is a 3-manifold and is independent of the choice of the matrix A ; cf. Hamm ([29], [30]). For $n > 3$, Neumann proved in [76] that $M^3(\alpha_1, \dots, \alpha_n)$ is an $\widetilde{SL}(2, \mathbb{R})$ -manifold whenever $\sum_{i=1}^n \frac{1}{\alpha_i} < n-2$. The case $\sum_{i=1}^n \frac{1}{\alpha_i} > n-2$ cannot occur for $n > 3$, and $\sum_{i=1}^n \frac{1}{\alpha_i} = n-2$ is only possible for $M^3(2, 2, 2, 2)$. The latter manifold is the Nil T^2 -bundle M_4 over S^1 ; see Section 6.

12 Homology 3-Spheres

The best known class of homology 3-spheres are the *Seifert homology spheres*, i.e., the homology 3-spheres that can be Seifert fibered. Seifert [99] showed that such a homology sphere necessarily has the 2-sphere as its orbit surface and is therefore of type $\{Oo, 0 \mid b; (\alpha_1, \beta_1), \dots, (\alpha_r, \beta_r)\}$. These manifolds are homology spheres if and only if the coefficients satisfy the equation

$$b\alpha_1 \cdots \alpha_r + \beta_1\alpha_2 \cdots \alpha_r + \alpha_1\beta_2 \cdots \alpha_r + \alpha_1\alpha_2 \cdots \beta_r = \pm 1.$$

In fact, if the left hand side is equal to -1 , then reversing the orientation of the manifolds yields $+1$ for the new left hand side. Therefore, without loss of generality, we can require the left hand side to be equal to $+1$. If two of the α_i have a common divisor, say d , then the left hand side is divisible by $d \neq 1$, which is impossible. Therefore, the α_i have to be pairwise coprime, and then $\gcd(\alpha_1 \cdots \alpha_r, \alpha_2 \cdots \alpha_r, \alpha_1\alpha_3 \cdots \alpha_r, \dots, \alpha_1 \cdots \alpha_{r-1}) = 1$, from which it follows that there are integers $b, \beta_1, \dots, \beta_r$ which satisfy the above equation. There is even a solution with $b = 0$, since $\gcd(\alpha_2 \cdots \alpha_r, \alpha_1\alpha_3 \cdots \alpha_r, \dots, \alpha_1 \cdots \alpha_{r-1}) = 1$. The β_i can be obtained as iterated cofactors by computing the gcd with the Euclidean algorithm. Some of the β_i will be negative and hence not satisfy the normalization $0 < \beta_i < \alpha_i$. This can be adjusted by simultaneously replacing β_i with $\beta_i + x_i\alpha_i$ and b by $b - x_i$. It also follows that β_i and α_i are coprime for every $i = 1, \dots, r$.

Theorem 26 (Seifert [99]) *For any set of $r \geq 3$ pairwise coprime integers $\alpha_1, \dots, \alpha_r \geq 2$, there is (up to reversing the orientation) a unique **Seifert fibered homology sphere** $\Sigma(\alpha_1, \dots, \alpha_r)$ with r exceptional fibers of the given multiplicities, and every fibered homology sphere arises this way. The only fibered homology sphere with finite fundamental group is the Poincaré sphere $\Sigma(2, 3, 5)$.*

All fibered homology spheres with infinite fundamental group are modeled on the geometry $\widetilde{SL}(2, \mathbb{R})$. If $r = 3$ and α_1, α_2 , and α_3 are coprime integers, then the fibered homology sphere $\Sigma(\alpha_1, \alpha_2, \alpha_3)$ is homeomorphic to the Brieskorn manifold $M(\alpha_1, \alpha_2, \alpha_3)$ and is called a *Brieskorn homology sphere*. Neumann and Raymond [77] showed that every Seifert homology sphere $\Sigma(\alpha_1, \dots, \alpha_r)$ is diffeomorphic to the generalized Brieskorn manifold with the same parameters.

Besides Seifert fibered homology spheres, there is an abundance of hyperbolic homology spheres. As mentioned above, standard techniques for constructing arbitrary homology spheres are Dehn surgery on a link in the 3-sphere S^3 (see Dehn [21], Seifert and Threlfall [100, §65], Lickorish [58] and Wallace [117]) or three-fold branched coverings of S^3 over a knot (see Alexander [1], Hilden [37], Montesinos [74], and Izmitiev and Joswig [43]). The connection between knots, links, and 3-manifolds attracted a lot of interest. See the books of Rolfsen [94], Prasolov and Sossinsky [89], and Saveliev [96]. The introduction of various new invariants for 3-manifolds in the last twenty years (see, in particular, the survey of Fintushel and Stern [24]) has led to rapid progress in low-dimensional topology.

References

- [1] J. W. Alexander. Note on Riemann spaces. *Bull. Am. Math. Soc.* **26**, 370–372 (1919–1920).
- [2] L. Auslander, L. Green, and F. Hahn. *Flows on homogeneous spaces*. Annals of Mathematics Studies **53**. Princeton University Press, Princeton, NJ, 1963.
- [3] R. Benedetti and C. Petronio. *Lectures on Hyperbolic Geometry*. Universitext. Springer-Verlag, Berlin, 1992.
- [4] L. Bieberbach. Über die Bewegungsgruppen der Euklidischen Räume. I. *Math. Ann.* **70**, 297–336 (1911).
- [5] L. Bieberbach. Über die Bewegungsgruppen der Euklidischen Räume. II. *Math. Ann.* **72**, 400–412 (1912).
- [6] L. J. Billera, R. Cushman, and J. A. Sanders. The Stanley decomposition of the harmonic oscillator. *Indag. Math.* **50**, 375–393 (1988).
- [7] A. Björner and F. H. Lutz. Simplicial manifolds, bistellar flips and a 16-vertex triangulation of the Poincaré homology 3-sphere. *Exp. Math.* **9**, 275–289 (2000).
- [8] A. Björner and F. H. Lutz. A 16-vertex triangulation of the Poincaré homology 3-sphere and non-PL spheres with few vertices. *Electronic Geometry Model No.* 2003.04.001 (2003).

- [9] K. Brauner. Zur Geometrie der Funktionen zweier komplexer Veränderlicher. III. Klassifikation der Singularitäten algebroider Kurven. *Abh. Math. Sem. Univ. Hamburg* **6**, 8–34 (1928).
- [10] U. Brehm and F. H. Lutz. Triangulations of Seifert manifolds. In preparation.
- [11] U. Brehm and J. Świątkowski. Triangulations of lens spaces with few simplices. SFB 288 Preprint No. 59, TU Berlin, 1993, 26 pages.
- [12] E. Brieskorn. Beispiele zur Differentialtopologie von Singularitäten. *Invent. Math.* **2**, 1–14 (1966).
- [13] E. Brieskorn. Examples of singular normal complex spaces which are topological manifolds. *Proc. Natl. Acad. Sci. USA* **55**, 1395–1397 (1966).
- [14] E. Brieskorn. Rationale Singularitäten komplexer Flächen. *Invent. Math.* **4**, 336–358 (1968).
- [15] E. J. Brody. The topological classification of the lens spaces. *Ann. Math.* **71**, 163–184 (1960).
- [16] P. J. Callahan, M. V. Hildebrand, and J. R. Weeks. A census of cusped hyperbolic 3-manifolds. *Math. Comput.* **68**, 321–332 (1999).
- [17] D. P. Cervone. Vertex-minimal simplicial immersions of the Klein bottle in three space. *Geom. Dedicata* **50**, 117–141 (1994).
- [18] B. Cipra (P. Zorn, ed.). *What’s Happening in the Mathematical Sciences. Volume 5*, Chapter Finite Math, 32–41. American Mathematical Society, Providence, RI, 2002.
- [19] D. Cox, J. Little, and D. O’Shea. *Ideals, Varieties, and Algorithms. An Introduction to Computational Algebraic Geometry and Commutative Algebra*. Undergraduate Texts in Mathematics. Springer-Verlag, New York, NY, 1992. Second edition, 1997.
- [20] B. Datta and N. Nilakantan. Two-dimensional weak pseudomanifolds on eight vertices. *Proc. Indian Acad. Sci. (Math. Sci.)* **112**, 257–281 (2002).
- [21] M. Dehn. Über die Topologie des dreidimensionalen Raumes. *Math. Ann.* **69**, 137–168 (1910).
- [22] S. Eilenberg and N. Steenrod. *Foundations of Algebraic Topology*. Princeton Mathematical Series **15**. Princeton University Press, Princeton, NJ, 1952.
- [23] B. Everitt. 3-manifolds from Platonic solids. [arXiv:math.GT/0104182](https://arxiv.org/abs/math/0104182), 2001, 8 pages; *Topology Appl.*, to appear.

- [24] R. Fintushel and R. J. Stern. Invariants for homology 3-spheres. *Geometry of Low-dimensional Manifolds, 1: Gauge Theory and Algebraic Surfaces*, Proc. Durham Symposium, 1989 (S. K. Donaldson and C. B. Thomas, eds.). London Mathematical Society Lecture Note Series **150**, 125–148. Cambridge University Press, Cambridge, 1990.
- [25] I. M. Gel'fand, M. M. Kapranov, and A. V. Zelevinsky. *Discriminants, Resultants, and Multidimensional Determinants*. Birkhäuser Verlag, Boston, MA, 1994.
- [26] W. Haken. Ein Verfahren zur Aufspaltung einer 3-Mannigfaltigkeit in irreduzible 3-Mannigfaltigkeiten. *Math. Z.* **76**, 427–467 (1961).
- [27] R. S. Hamilton. Three-manifolds with positive Ricci curvature. *J. Differ. Geom.* **17**, 255–306 (1982).
- [28] R. S. Hamilton. Non-singular solutions of the Ricci flow on three-manifolds. *Commun. Anal. Geom.* **7**, 695–729 (1999).
- [29] H. A. Hamm. Lokale topologische Eigenschaften komplexer Räume. *Math. Ann.* **191**, 235–252 (1971).
- [30] H. A. Hamm. Exotische Sphären als Umgebungsänderer in speziellen komplexen Räumen. *Math. Ann.* **197**, 44–56 (1972).
- [31] W. Hantzsche and H. Wendt. Dreidimensionale euklidische Raumformen. *Math. Ann.* **110**, 593–611 (1935).
- [32] A. E. Hatcher. A proof of the Smale conjecture, $\text{Diff}(S^3) \simeq O(4)$. *Ann. Math.* **117**, 553–607 (1983).
- [33] P. Heegaard. Sur l' « analysis situs ». *Bull. Soc. math. France* **44**, 161–242 (1916).
- [34] J. Hempel. *3-Manifolds*. Annals of Mathematics Studies **86**. Princeton University Press, Princeton, NJ, 1976.
- [35] J. Hempel and W. Jaco. Fundamental groups of 3-manifolds which are extensions. *Ann. Math.* **95**, 86–98 (1972).
- [36] M. V. Hildebrand and J. R. Weeks. A computer generated census of cusped hyperbolic 3-manifolds. *Computers and Mathematics*, Proc. Conf., MIT, Cambridge, MA, 1989 (E. Kaltofen and S. M. Watt, eds.), 53–59. Springer-Verlag, New York, NY, 1989.
- [37] H. M. Hilden. Every closed orientable 3-manifold is a 3-fold branched covering space of S^3 . *Bull. Am. Math. Soc.* **80**, 1243–1244 (1974).
- [38] F. Hirzebruch. The topology of normal singularities of an algebraic surface. *Sémin. Bourbaki* n°250, 1–9 (1962/63).

- [39] F. Hirzebruch. Singularities and exotic spheres. *Sémin. Bourbaki* n°314, 1–20 (1966/67).
- [40] F. Hirzebruch and K. H. Mayer. *$O(n)$ -Mannigfaltigkeiten, exotische Sphären und Singularitäten*. Lecture Notes in Mathematics **57**. Springer-Verlag, Berlin, 1968.
- [41] C. D. Hodgson and J. R. Weeks. Symmetries, isometries and length spectra of closed hyperbolic three-manifolds. *Exp. Math.* **3**, 261–274 (1994).
- [42] H. Hopf. Zum Clifford-Kleinschen Raumproblem. *Math. Ann.* **95**, 313–339 (1926).
- [43] I. Izmitiev and M. Joswig. Branched coverings, triangulations, and 3-manifolds. [arXiv:math.GT/0108202v2](https://arxiv.org/abs/math/0108202v2), 2002, 42 pages; *Adv. Geom.*, to appear.
- [44] W. H. Jaco and P. B. Shalen. *Seifert Fibered Spaces in 3-Manifolds*. Memoirs of the American Mathematical Society **21**. American Mathematical Society, Providence, RI, 1979.
- [45] W. H. Jaco and J. L. Tollefson. Algorithms for the complete decomposition of a closed 3-manifold. *Ill. J. Math.* **39**, 358–406 (1995).
- [46] K. Johannson. *Homotopy Equivalences of 3-Manifolds with Boundaries*. Lecture Notes in Mathematics **761**. Springer-Verlag, Berlin, 1979.
- [47] M. Jungerman and G. Ringel. Minimal triangulations on orientable surfaces. *Acta Math.* **145**, 121–154 (1980).
- [48] M. A. Kervaire. A manifold which does not admit any differentiable structure. *Comment. Math. Helv.* **34**, 257–270 (1960).
- [49] M. A. Kervaire and J. W. Milnor. Groups of homotopy spheres: I. *Ann. Math.* **77**, 504–537 (1963).
- [50] W. Killing. Ueber die Clifford-Klein'schen Raumformen. *Math. Ann.* **39**, 257–278 (1891).
- [51] F. Klein. *Vorlesungen über das Ikosaeder und die Auflösung der Gleichungen vom fünften Grade*. B. G. Teubner, Leipzig, 1884.
- [52] F. Klein. Zur Nicht-Euklidischen Geometrie. *Math. Ann.* **37**, 544–572 (1890).
- [53] F. Klein. *Vorlesungen über das Ikosaeder und die Auflösung der Gleichungen vom fünften Grade – Reprogr. Nachdr. der Ausg. Leipzig, Teubner 1884 / hrsg. mit einer Einf. und mit Kommentaren von Peter Slodowy*. Birkhäuser Verlag, Basel, B. G. Teubner, Stuttgart, 1993.

- [54] H. Kneser. Geschlossene Flächen in dreidimensionalen Mannigfaltigkeiten. *Jber. d. Dt. Math.-Verein.* **38**, 248–260 (1929).
- [55] W. Kühnel and G. Lassmann. The rhombidodecahedral tessellation of 3-space and a particular 15-vertex triangulation of the 3-dimensional torus. *Manuscr. Math.* **49**, 61–77 (1984).
- [56] C. W. Lee. Subdivisions and triangulations of polytopes. *Handbook of Discrete and Computational Geometry* (J. E. Goodman and J. O’Rourke, eds.), Chapter 14, 271–290. CRC Press, Boca Raton, FL, 1997.
- [57] R. Lee. Semicharacteristic classes. *Topology* **12**, 183–199 (1973).
- [58] W. B. R. Lickorish. A representation of orientable combinatorial 3-manifolds. *Ann. Math.* **76**, 531–540 (1962).
- [59] F. Löbell. Beispiele geschlossener dreidimensionaler Clifford-Kleinscher Räume negativer Krümmung. *Berichte über d. Verhandl. d. Sächs. Ges. d. Wiss., Math.-Phys. Kl.* **83**, 167–174 (1931).
- [60] F. H. Lutz. *Triangulated Manifolds with Few Vertices and Vertex-Transitive Group Actions*. Dissertation. Shaker Verlag, Aachen, 1999, 146 pages.
- [61] F. H. Lutz. GAP-program SEIFERT. Version Nov/2003. (<http://www.math.tu-berlin.de/diskregeom/stellar/SEIFERT>)
- [62] F. H. Lutz. The Manifold Page. (<http://www.math.tu-berlin.de/diskregeom/stellar/>)
- [63] F. H. Lutz. Triangulated surfaces with few vertices. In preparation.
- [64] F. H. Lutz. Triangulations of torus bundles. In preparation.
- [65] J. Maher and J. H. Rubinstein. Period three actions on the three-sphere. *Geom. Topol.* **7**, 329–397 (2003).
- [66] C. McMullen. Riemann surfaces and the geometrization of 3-manifolds. *Bull. Am. Math. Soc., New Ser.* **27**, 207–216 (1992).
- [67] J. W. Milnor. Groups which act on S^n without fixed points. *Am. J. Math.* **79**, 623–630 (1957).
- [68] J. W. Milnor. A unique decomposition theorem for 3-manifolds. *Am. J. Math.* **84**, 1–7 (1962).
- [69] J. W. Milnor. *Singular Points of Complex Hypersurfaces*. Annals of Mathematics Studies **61**. Princeton University Press, Princeton, NJ, 1968.

- [70] J. W. Milnor. On the 3-dimensional Brieskorn manifolds $M(p, q, r)$. *Knots, Groups and 3-Manifolds, Papers Dedicated to the Memory of R. H. Fox* (L. P. Neuwirth, ed.). Annals of Mathematics Studies **84**, 175–225. Princeton University Press, Princeton, NJ, 1975.
- [71] J. W. Milnor. Hyperbolic geometry: the first 150 years. *Bull. Am. Math. Soc., New Ser.* **6**, 9–24 (1982).
- [72] A. F. Möbius. Mittheilungen aus Möbius' Nachlass: I. Zur Theorie der Polyëder und der Elementarverwandtschaft. *Gesammelte Werke II* (F. Klein, ed.), 515–559. Verlag von S. Hirzel, Leipzig, 1886.
- [73] E. E. Moise. Affine structures in 3-manifolds. V. The triangulation theorem and Hauptvermutung. *Ann. Math.* 96–114 (1952).
- [74] J. M. Montesinos. Three-manifolds as 3-fold branched covers of S^3 . *Quart. J. Math. Oxford, II. Ser.* **27**, 85–94 (1976).
- [75] R. Myers. Free involutions on lens spaces. *Topology* **20**, 313–318 (1981).
- [76] W. D. Neumann. Brieskorn complete intersections and automorphic forms. *Invent. Math.* **42**, 285–293 (1977).
- [77] W. D. Neumann and F. Raymond. Seifert manifolds, plumbing, μ -invariant and orientation reversing maps. *Algebraic and Geometric Topology*, Proc. Symposium held at Santa Barbara in honor of Raymond L. Wilder, 1977 (K. C. Millett, ed.). Lecture Notes in Mathematics **664**, 163–196. Springer-Verlag, Berlin, 1978.
- [78] W. D. Neumann and G. A. Swarup. Canonical decompositions of 3-manifolds. *Geom. Topol.* **1**, 21–40 (1997).
- [79] W. Nowacki. Die euklidischen, dreidimensionalen, geschlossenen und offenen Raumformen. *Comment. Math. Helv.* **7**, 81–93 (1934–1935).
- [80] P. Orlik. Weighted homogeneous polynomials and fundamental groups. *Topology* **9**, 267–273 (1970).
- [81] P. Orlik. *Seifert Manifolds*. Lecture Notes in Mathematics **291**. Springer-Verlag, Berlin, 1972.
- [82] P. Orlik and F. Raymond. On 3-manifolds with local $SO(2)$ action. *Quart. J. Math. Oxford, II. Ser.* **20**, 143–160 (1969).
- [83] P. Orlik, E. Vogt, and H. Zieschang. Zur Topologie gefaserner dreidimensionaler Mannigfaltigkeiten. *Topology* **6**, 49–64 (1967).
- [84] G. Perelman. The entropy formula for the Ricci flow and its geometric applications. [arXiv:math.DG/0211159](https://arxiv.org/abs/math/0211159), 2002, 39 pages.

- [85] G. Perelman. Finite extinction time for the solutions to the Ricci flow on certain three-manifolds. [math.DG/0307245](#), 2003, 7 pages.
- [86] G. Perelman. Ricci flow with surgery on three-manifolds. [math.DG/0303109](#), 2003, 22 pages.
- [87] F. Pham. Formules de Picard-Lefschetz généralisées et ramification des intégrales. *Bull. Soc. math. France* **93**, 333–367 (1965).
- [88] H. Poincaré. Cinquième complément à l’analysis situs. *Rend. Circ. Mat. Palermo* **18**, 45–110 (1904).
- [89] V. V. Prasolov and A. B. Sossinsky. *Knots, Links, Braids and 3-Manifolds. An Introduction to the New Invariants in Low-Dimensional Topology*. Translations of Mathematical Monographs **154**. American Mathematical Society, Providence, RI, 1997.
- [90] F. Raymond and A. T. Vasquez. 3-manifolds whose universal coverings are Lie groups. *Topology Appl.* **12**, 161–179 (1981).
- [91] K. Reidemeister. Homotopieringe und Linsenräume. *Abh. Math. Sem. Univ. Hamburg* **11**, 102–109 (1936).
- [92] G. Ringel. Wie man die geschlossenen nichtorientierbaren Flächen in möglichst wenig Dreiecke zerlegen kann. *Math. Ann.* **130**, 317–326 (1955).
- [93] G. Ringel. *Map Color Theorem*. Grundlehren der mathematischen Wissenschaften **209**. Springer-Verlag, Berlin, 1974.
- [94] D. Rolfsen. *Knots and Links*. Mathematics Lecture Series **7**. Publish or Perish, Berkeley, CA, 1976.
- [95] F. Santos. A point set whose space of triangulations is disconnected. *J. Am. Math. Soc.* **13**, 611–637 (2000).
- [96] N. Saveliev. *Lectures on the Topology of 3-Manifolds. An Introduction to the Casson Invariant*. de Gruyter Textbook. Walter de Gruyter, Berlin, 1999.
- [97] P. Scott. The geometries of 3-manifolds. *Bull. Lond. Math. Soc.* **15**, 401–487 (1983).
- [98] H. Seifert. Konstruktion dreidimensionaler geschlossener Räume. *Berichte über d. Verhandl. d. Sächs. Ges. d. Wiss., Math.-Phys. Kl.* **83**, 26–66 (1931).
- [99] H. Seifert. Topologie dreidimensionaler gefaserner Räume. *Acta Math.* **60**, 147–238 (1933).
- [100] H. Seifert and W. Threlfall. *Lehrbuch der Topologie*. B. G. Teubner, Leipzig, 1934.

- [101] H. Seifert and W. Threlfall. *A Textbook of Topology*. Pure and Applied Mathematics **89**. Academic Press, New York, NY, 1980.
- [102] N. E. Steenrod. *The Topology of Fibre Bundles*. Princeton Mathematical Series **14**. Princeton University Press, Princeton, NJ, 1951.
- [103] J. Stillwell. *Classical Topology and Combinatorial Group Theory*. Graduate Texts in Mathematics **72**. Springer-Verlag, New York, NY, 1980. Second edition, 1993.
- [104] J. Stillwell. *Sources of Hyperbolic Geometry*. History of Mathematics **10**. American Mathematical Society, Providence, RI, 1996.
- [105] C. B. Thomas. Free actions by finite groups on S^3 . *Algebraic and Geometric Topology* (R. J. Milgram, ed.). Proceedings of Symposia in Pure Mathematics **32**, Part 1, 125–130. American Mathematical Society, Providence, RI, 1978.
- [106] W. Threlfall and H. Seifert. Topologische Untersuchung der Diskontinuitätsbereiche endlicher Bewegungsgruppen des dreidimensionalen sphärischen Raumes. *Math. Ann.* **104**, 1–70 (1931).
- [107] W. Threlfall and H. Seifert. Topologische Untersuchung der Diskontinuitätsbereiche endlicher Bewegungsgruppen des dreidimensionalen sphärischen Raumes (Schluß). *Math. Ann.* **107**, 543–586 (1933).
- [108] W. P. Thurston. Three dimensional manifolds, Kleinian groups and hyperbolic geometry. *Bull. Am. Math. Soc., New Ser.* **6**, 357–381 (1982).
- [109] W. P. Thurston. Hyperbolic structures on 3-manifolds. I: Deformation of acylindrical manifolds. *Ann. Math.* **124**, 203–246 (1986).
- [110] W. P. Thurston. *The Geometry and Topology of Three-Manifolds*. Electronic version 1.1 – March 2002. Mathematical Sciences Research Institute, Berkeley, CA, 2002. (<http://www.msri.org/publications/books/gt3m/>)
- [111] W. P. Thurston (S. Levy, ed.). *Three-Dimensional Geometry and Topology, Volume 1*. Princeton University Press, Princeton, NJ, 1997.
- [112] H. Tietze. Über die topologischen Invarianten mehrdimensionaler Mannigfaltigkeiten. *Monatsh. Math. Phys.* **19**, 1–118 (1908).
- [113] J. L. Tollefson. The compact 3-manifolds covered by $S^2 \times R^1$. *Proc. Am. Math. Soc.* **45**, 461–462 (1974).
- [114] P. Wagreich. Singularities of complex surfaces with solvable local fundamental group. *Topology* **11**, 51–72 (1972).
- [115] F. Waldhausen. Eine Klasse von 3-dimensionalen Mannigfaltigkeiten. I. *Invent. Math.* **3**, 308–333 (1967).

- [116] F. Waldhausen. Eine Klasse von 3-dimensionalen Mannigfaltigkeiten. II. *Invent. Math.* **4**, 87–117 (1967).
- [117] A. H. Wallace. Modifications and cobounding manifolds. *Can. J. Math.* **12**, 503–528 (1960).
- [118] C. Weber and H. Seifert. Die beiden Dodekaederräume. *Math. Z.* **37**, 237–253 (1933).
- [119] J. H. C. Whitehead. On incidence matrices, nuclei and homotopy types. *Ann. Math.* **42**, 1197–1239 (1941).
- [120] J. A. Wolf. *Spaces of Constant Curvature*. McGraw-Hill Series in Higher Mathematics. McGraw-Hill Book Company, New York, NY, 1967.

Frank H. Lutz
Technische Universität Berlin
Fakultät II - Mathematik und Naturwissenschaften
Institut für Mathematik, Sekr. MA 6-2
Straße des 17. Juni 136
D-10623 Berlin
lutz@math.tu-berlin.de