

Lectures on 2D Yang-Mills Theory, Equivariant Cohomology and Topological Field Theories

Stefan Cordes, Gregory Moore, and Sanjaye Ramgoolam

stefan@waldzell.physics.yale.edu

moore@castalia.physics.yale.edu

skr@genesis2.physics.yale.edu

Dept. of Physics

Yale University

New Haven, CT 06511

Abstract

These are expository lectures reviewing (1) recent developments in two-dimensional Yang-Mills theory and (2) the construction of topological field theory Lagrangians. Topological field theory is discussed from the point of view of infinite-dimensional differential geometry. We emphasize the unifying role of equivariant cohomology both as the underlying principle in the formulation of BRST transformation laws and as a central concept in the geometrical interpretation of topological field theory path integrals.

Contents

| | |
|---|----|
| 1. Introduction | 7 |
| 1.1. Part I: Yang-Mills as a string theory | 8 |
| 1.1.1. General issues | 8 |
| 1.1.2. Exact amplitudes | 8 |
| 1.1.3. Hilbert Space | 9 |
| 1.1.4. Covering Spaces | 9 |
| 1.1.5. $1/N$ Expansions of Amplitudes | 9 |
| 1.1.6. Interpreting the sum | 9 |
| 1.1.7. The challenge | 9 |
| 1.2. Related Topics not Discussed | 10 |
| 1.3. Some related reviews | 11 |
| 2. Yang-Mills as a String Theory | 12 |
| 2.1. Motivations for strings | 12 |
| 2.2. The case of two dimensions | 14 |
| 2.2.1. What to look for | 14 |
| 3. Exact Solution of Yang-Mills in Two Dimensions | 15 |
| 3.1. Special features of two dimensions | 15 |
| 3.2. A larger space of theories | 16 |
| 3.3. Hilbert space | 18 |
| 3.4. Exact results for amplitudes | 21 |
| 3.4.1. Basic Amplitudes | 21 |
| 3.4.2. RG Invariance | 22 |
| 3.4.3. Surfaces with nontrivial topology | 23 |
| 3.5. Exact Wilson loop averages | 25 |
| 3.5.1. Nonintersecting loops | 25 |
| 3.5.2. Intersecting loops | 26 |
| 3.6. YM_2 and topological field theory | 27 |
| 3.6.1. $e^2 = 0$ and Flat Connections | 27 |
| 3.6.2. Chern-Simons theory and RCFT | 28 |
| 3.7. Axiomatic Approach | 28 |
| 4. From YM_2 to Strings: The Canonical Approach | 29 |
| 4.1. Representation theory and Free Fermions | 29 |
| 4.2. $SU(N)$ and $U(N)$ | 31 |
| 4.3. Second Quantization | 32 |
| 4.4. Large N Limit: Map to CFT | 32 |
| 4.4.1. Chiral, Antichiral and Coupled Reps | 32 |
| 4.4.2. Mapping to CFT | 33 |
| 4.5. Bosonization | 36 |
| 4.6. Schur-Weyl duality | 38 |
| 4.7. The string interpretation | 39 |
| 4.7.1. Back to class functions | 40 |
| 4.8. String Interactions | 41 |
| 4.8.1. The Fermi fluid picture | 42 |

| | |
|---|----|
| 4.9. Casimirs and Symmetric Groups | 44 |
| 4.10. Appendix: Higher Casimirs | 44 |
| 4.10.1. From cycle operators to Casimirs | 47 |
| 4.10.2. Casimirs for $SU(N)$ | 48 |
| 5. Covering Spaces | 49 |
| 5.1. Motivation | 49 |
| 5.2. Maps of $\Sigma_W \rightarrow \Sigma_T$ | 51 |
| 5.2.1. Homotopy groups | 51 |
| 5.2.2. Branched covers | 51 |
| 5.3. Hurwitz spaces | 55 |
| 5.4. Hurwitz Spaces and Holomorphic maps | 56 |
| 5.5. Fiber Bundle approach to Hurwitz space | 57 |
| 5.6. Riemann and Hurwitz Moduli Spaces | 58 |
| 6. $1/N$ Expansions of YM_2 amplitudes | 58 |
| 6.1. Some preliminary identities from group theory | 58 |
| 6.1.1. Finite group identities | 58 |
| 6.1.2. Powers of dimensions | 59 |
| 6.2. Chiral Gross-Taylor Series | 59 |
| 6.3. Nonchiral Sum | 62 |
| 6.4. Area Functions | 64 |
| 6.5. Geometrical Interpretation of the A -dependence | 64 |
| 6.5.1. $i > 0$: Movable branch points | 65 |
| 6.5.2. $t > 0$: Tubes | 65 |
| 6.5.3. $h > 0$: Bubbled handles | 66 |
| 6.6. Generalizations | 67 |
| 6.6.1. Higher Casimirs | 67 |
| 6.6.2. Nonperturbative corrections | 68 |
| 6.6.3. $O(N)$ and $Sp(2N)$ Yang Mills | 68 |
| 7. Euler characters | 69 |
| 7.1. Chiral GT partition function | 69 |
| 7.1.1. Recasting the CGTS as a sum over branched coverings | 69 |
| 7.1.2. Euler characters | 71 |
| 7.1.3. Connected vs. Disconnected surfaces | 73 |
| 7.2. Nonchiral partition function | 74 |
| 7.3. Inclusion of area | 75 |
| 8. Wilson loops | 75 |
| 9. Introduction to part II: General Remarks on Topological Field Theories | 75 |
| 9.1. Cohomological Field Theories | 75 |
| 9.1.1. String reformulation of Yang-Mills | 76 |
| 9.1.2. Calculation of Physical Quantities | 77 |
| 9.1.3. Interactions with mathematics | 77 |
| 9.1.4. A Deeper formulation of String theory | 78 |
| 9.2. Detailed Overview | 78 |
| 9.2.1. Equivariant cohomology | 79 |

| | |
|---|-----|
| 9.2.2. Mathai-Quillen formalism | 79 |
| 9.2.3. Applications: TFT's without Local Symmetry | 79 |
| 9.2.4. Local Symmetry | 79 |
| 9.2.5. The examples | 79 |
| 9.3. Paradigm | 80 |
| 9.3.1. General Remarks on Moduli Spaces | 81 |
| 10. Equivariant Cohomology | 81 |
| 10.1. Classifying Spaces | 81 |
| 10.2. Characteristic classes | 83 |
| 10.2.1. Basic Forms | 85 |
| 10.3. Weil Algebra | 85 |
| 10.3.1. Basic subcomplex | 86 |
| 10.4. Equivariant Cohomology of Manifolds | 88 |
| 10.5. Other formulations of equivariant cohomology | 89 |
| 10.5.1. Cartan Model | 89 |
| 10.5.2. BRST Model | 90 |
| 10.5.3. Equivalences | 90 |
| 10.5.4. Axiomatic Formulation | 91 |
| 10.6. Example 1: S^1 -Equivariant Cohomology | 91 |
| 10.6.1. Point | 91 |
| 10.6.2. S^2 | 92 |
| 10.7. Example 2: \mathcal{G} -Equivariant cohomology of \mathcal{A} | 93 |
| 10.8. Equivariant Cohomology vs. Lie-Algebra Cohomology | 94 |
| 10.8.1. Lie Algebra cohomology and BRST quantization | 94 |
| 10.8.2. Supersymmetrized Lie Algebra cohomology | 95 |
| 10.9. Equivariant Cohomology and Twisted $N = 2$ Supersymmetry | 96 |
| 10.10. Equivariant Cohomology and Symplectic Group Actions | 97 |
| 10.10.1. Case of YM_2 | 98 |
| 11. Intersection Numbers and their Integral Representations | 98 |
| 11.1. Thom Class and Euler Class | 99 |
| 11.1.1. Thom class | 99 |
| 11.1.2. Euler class | 101 |
| 11.1.3. Two key properties | 101 |
| 11.2. Universal Thom Class | 102 |
| 11.3. Mathai-Quillen representative of the Thom class | 103 |
| 11.4. Integral Representation: Antighosts | 105 |
| 11.5. Integral Representation: Q-Invariance | 106 |
| 11.6. Cartan Model Representative | 107 |
| 11.7. Other integral representations of U | 108 |
| 11.8. Dependence on choices and "BRST Decoupling" | 108 |
| 11.8.1. Independence of coordinates ρ_a | 109 |
| 11.8.2. Independence of metric on V | 109 |
| 11.9. Superspace and "physical notation" | 110 |
| 11.9.1. Functions on superspace = Differential forms | 110 |

| | |
|--|-----|
| 11.9.2. Physical interpretation | 110 |
| 11.10. The Localization Principle | 111 |
| 11.10.1. Localizing support | 111 |
| 11.10.2. Example: From Gauss-Bonnet to Poincaré-Hopf | 112 |
| 11.10.3. General Localization Formula | 114 |
| 11.10.4. Q Fixed-Points | 116 |
| 11.10.5. Physical Interpretation | 117 |
| 11.11. Partition Functions | 117 |
| 11.12. Localization and Integration of Equivariant Differential Forms | 117 |
| 11.12.1. The Duistermaat-Heckman theorem | 118 |
| 11.12.2. Nonabelian Localization | 119 |
| 11.12.3. Application: Weak-coupling limit of YM_2 | 120 |
| 12. Supersymmetric Quantum Mechanics | 121 |
| 12.1. Action and Supersymmetry | 122 |
| 12.2. MQ interpretation of SQM | 123 |
| 12.3. Canonical Quantization | 125 |
| 12.3.1. $\text{Tr}(-1)^F$ | 126 |
| 12.3.2. The partition function | 127 |
| 12.4. Appendix 1: The two-dimensional supersymmetric nonlinear sigma model | 128 |
| 12.4.1. Superfields | 128 |
| 12.4.2. $N = 2, d = 2$ Supersymmetric Sigma Models: Field Content | 129 |
| 12.4.3. $N = 1, d = 2$ Supersymmetric Sigma Models | 129 |
| 12.4.4. Canonical Quantization | 131 |
| 12.4.5. Dimensional Reduction | 131 |
| 12.5. Appendix 2: Index theorems for some elliptic operators | 131 |
| 12.5.1. The Index of the Dirac Complex | 132 |
| 12.5.2. The Index of the Twisted Dirac Complex | 133 |
| 12.5.3. The Index of the Dolbeault Complex | 133 |
| 12.6. Appendix 3: Noncompact X and runaway vacua | 134 |
| 12.7. Appendix 4: Canonical quantization with $W \neq 0$: Morse theory | 135 |
| 13. Topological sigma models | 138 |
| 13.1. Fields and Equations. | 138 |
| 13.2. Differential Forms on $\text{MAP}(\Sigma, X)$ | 139 |
| 13.3. Vector Bundle | 140 |
| 13.4. Choice of connection | 140 |
| 13.5. BRST Complex | 142 |
| 13.6. Gauge Fermion and Action | 143 |
| 13.7. Observables | 143 |
| 13.8. Correlation Functions | 145 |
| 13.8.1. Localization on moduli space | 145 |
| 13.8.2. Zeromodes and the Index theorem | 146 |
| 13.8.3. Reduction to Enumerative Geometry | 146 |
| 13.9. Quantum Cohomology | 147 |
| 13.10. Relation to the physical sigma model | 148 |

| | |
|--|-----|
| 13.10.1. Kähler target | 148 |
| 13.10.2. Superspace | 149 |
| 13.10.3. Symmetries | 150 |
| 13.10.4. Topological twisting | 151 |
| 13.10.5. Comparison to the MQ form | 152 |
| 13.11. Canonical approach | 153 |
| 13.12. Appendix: Examples of Moduli spaces of Holomorphic Maps | 153 |
| 14. Topological Theories with Local Symmetry | 154 |
| 14.1. Projection and Localization | 154 |
| 14.2. The Projection Form | 157 |
| 14.3. A BRST Construction of $\Phi(P \rightarrow M)$ for Principal Bundles | 158 |
| 14.3.1. Characterization of $\Phi(P \rightarrow M)$ | 158 |
| 14.3.2. Geometry of Principal Bundles | 159 |
| 14.3.3. Construction of Φ | 160 |
| 14.4. Assembling the Pieces: No Gauge Fixing. | 164 |
| 14.4.1. Equivariant Thom Class | 165 |
| 14.4.2. Q -exact actions | 167 |
| 14.5. Faddeev-Popov Gauge Fixing | 169 |
| 14.6. The general construction of cohomological field theory. | 172 |
| 14.6.1. Fields | 172 |
| 14.6.2. Observables | 172 |
| 14.6.3. Action | 173 |
| 14.6.4. Correlators | 173 |
| 15. Topological Yang-Mills Theory | 173 |
| 15.1. Basic Data | 173 |
| 15.2. Equations | 174 |
| 15.3. Vector Bundles | 175 |
| 15.4. Connection on \mathcal{V}_+ and \mathcal{E}_+ | 175 |
| 15.5. BRST Complex | 176 |
| 15.5.1. Weil Algebra | 176 |
| 15.5.2. BRST Model | 176 |
| 15.5.3. Cartan Model | 177 |
| 15.5.4. Antighosts | 178 |
| 15.6. Lagrangian | 178 |
| 15.6.1. Localization Lagrangian | 178 |
| 15.6.2. Projection Lagrangian | 179 |
| 15.6.3. Gauge-Fixing Lagrangian | 179 |
| 15.6.4. MQ form on $\mathcal{E}_+ \rightarrow \mathcal{M}$ | 180 |
| 15.7. $D = 2$: Flat Connections | 181 |
| 15.8. Observables | 182 |
| 15.8.1. The Big Bundle | 182 |
| 15.8.2. Universal Connection | 185 |
| 15.8.3. QFT Representative | 186 |
| 15.9. Correlation Functions | 188 |

| | |
|--|-----|
| 15.9.1. Reducible connections | 189 |
| 15.10. The canonical formulation: Floer Homology | 190 |
| 15.11. Relation to “physical” Yang-Mills: $D = 4$ | 190 |
| 15.11.1. The $N = 2$ Lagrangian | 190 |
| 15.11.2. Topological Twisting | 192 |
| 15.11.3. Comparison to the MQ form | 193 |
| 15.11.4. The Energy-Momentum Tensor | 193 |
| 15.12. Relation to “physical” Yang-Mills: $D = 2$ | 194 |
| 15.12.1. Holomorphic maps and flat connections | 195 |
| 16. 2D Topological Gravity | 196 |
| 16.1. Formulation 1: $\mathcal{G} = \text{Diff}(\Sigma) \ltimes \text{Weyl}(\Sigma)$ | 196 |
| 16.1.1. BRST Complex | 196 |
| 16.1.2. Lagrangian | 197 |
| 16.2. Formulation 2: $\mathcal{G} = \text{Diff}(\Sigma)$ | 199 |
| 16.2.1. Equations | 199 |
| 16.2.2. BRST Complex | 200 |
| 16.2.3. Lagrangian | 200 |
| 16.3. Formulation 3: $\mathcal{G} = \text{Diff}(\Sigma) \times L.L.(\Sigma)$ | 202 |
| 16.3.1. Equations | 202 |
| 16.3.2. BRST Complex | 202 |
| 16.3.3. Lagrangians | 203 |
| 16.4. Formulation 4: $\mathcal{G} = \widehat{\text{Diff}}(\Sigma)$ | 203 |
| 16.5. Observables | 204 |
| 16.6. Hamiltonian Approach | 206 |
| 16.7. Correlation Functions | 206 |
| 17. Topological string theory | 207 |
| 17.1. Basic Data | 207 |
| 17.2. Equations | 207 |
| 17.3. Antighost bundle | 207 |
| 17.4. Connection on antighost bundle | 208 |
| 17.5. BRST Complex | 209 |
| 17.6. Lagrangian | 209 |
| 17.6.1. Localization | 209 |
| 17.6.2. $\Psi_{\text{projection}}$ | 209 |
| 17.6.3. The Full Action | 210 |
| 17.7. Index | 210 |
| 17.8. Example: Riemann surface target | 211 |
| 18. YM_2 as a topological string theory | 211 |
| 18.1. Extending the fieldspace | 212 |
| 18.1.1. “Cofields” | 212 |
| 18.2. Equations | 213 |
| 18.3. BRST Complex | 214 |
| 18.4. Lagrangian | 214 |
| 18.5. Localization | 214 |

| | |
|--|-----|
| 18.6. Nonchiral case | 215 |
| 18.7. Perturbing by the area | 216 |
| 18.8. Horava’s Theory | 218 |
| 19. Euler character theories | 218 |
| 20. Four Dimensions: A Conjecture | 220 |
| 21. Conclusion | 221 |
| Appendix A. Background from Differential Geometry | 221 |
| A.1. Differential forms | 221 |
| A.1.1. Hodge dual | 222 |
| A.2. Bundles | 222 |
| A.2.1. Fiber Bundles | 222 |
| A.2.2. Pulled back bundles | 224 |
| A.2.3. Vector Bundles | 224 |
| A.2.4. Principal Bundles | 225 |
| A.2.5. Associated vector bundles. | 226 |
| A.3. Connections on Vector Bundles and Principal Bundles | 227 |
| A.3.1. Connections on Vector Bundles | 227 |
| A.3.2. Vertical Tangent Vectors on Principal Bundles | 228 |
| A.3.3. Connections on Principal Bundles | 229 |
| A.3.4. Connection on an Associated Vector Bundle | 231 |
| A.4. Curvature and Holonomy | 232 |
| A.4.1. Holonomy | 232 |
| A.4.2. Curvature | 233 |
| A.5. Yang-Mills equations and action | 235 |
| A.5.1. Infinite Dimensional Principal Bundles | 236 |

1. Introduction

These lectures focus on a confluence of two themes in recent work on geometrical quantum field theory. The first theme is the formulation of Yang-Mills theory as a theory of strings. The second theme is the formulation of a class of topological field theories known as “cohomological field theories.”

Accordingly, the lectures are divided into two parts. Part I reviews various issues which arise in searching for a string formulation of Yang-Mills theory. Certain results of part I motivate a thorough study of cohomological field theory. That is the subject of part II.

Part I is published in [53]. Part II is published in [54]. An electronic version of the entire set of lectures is available in [55]. In [54] a cross-reference to chapter two of [55] is labelled chapter I.2, etc.

We now give an overview of the contents of part I of the lectures. A detailed overview of part II may be found in chapter 9. Some background material on differential geometry is collected in appendix A.

1.1. Part I: Yang-Mills as a string theory

The very genesis of string theory is in attempts to formulate a theory of the strong interactions. In this sense, the idea that Yang-Mills theory is a string theory is over 20 years old. The idea is attractive, but has proven elusive. In the last two years there has been some significant progress on this problem.

1.1.1. General issues

In chapter 2 we discuss the general pros and cons of formulating YM as a string theory. The upshot is:

- a.) There are good heuristic motivations, but few solid results.
- b.) String signatures will be clearest in the $1/N$ expansion.
- c.) Any YM string will differ significantly from the much-studied critical string.

We also describe the program initiated by D. Gross: examine the $1/N$ expansion of two-dimensional Yang-Mills amplitudes and look for stringy signatures. Gross' program has been the source of much recent progress.

1.1.2. Exact amplitudes

In order to carry out Gross' program, we describe the very beautiful exact solution of YM_2 in chapter 3. The upshot is:

- a.) The Hilbert space is the space of class functions on the gauge group G .
- b.) The amplitudes are known exactly. For example, in equation (3.20) we derive the famous result which states that if a closed oriented spacetime Σ_T has area a , then the partition function of Yang-Mills theory for gauge group G is

$$Z = \sum_R (\dim R)^{\chi(\Sigma_T)} e^{-e^2 a C_2(R)} \quad (1.1)$$

where we sum over unitary irreducible representations of G , $\chi(\Sigma_T)$ is the Euler character of Σ_T , and $C_2(R)$ is the quadratic Casimir in the representation R . Similar results hold for all amplitudes.

1.1.3. Hilbert Space

With the exact amplitudes in hand we begin our study of the $1/N$ expansion. The first step is to understand the Hilbert space of the theory in stringy terms. This is done in chapter 4. The consequence is that one can reformulate the Hilbert space of the theory as a Fock space of string states. Wilson loops create rings of glue. The topological properties of this ring of glue characterize the state. We also describe briefly some nice relations to conformal field theories of fermions and bosons.

1.1.4. Covering Spaces

The description of states as rings of glue winding around the spatial circle leads naturally to the discussion of coverings of surfaces by surfaces: the worldsheet swept out by a ring of glue defines a covering of spacetime.

We review the mathematics of covering surfaces in chapter 5. The most important points are:

- a.) Branched covers are described in terms of symmetric groups, see 5.2.2.
- b.) Branched covers may be identified with holomorphic maps.

1.1.5. $1/N$ Expansions of Amplitudes

With our understanding of branched covers we are then ready to describe in detail the beautiful calculations of Gross and Taylor of the $1/N$ expansions of amplitudes in YM_2 [94]. We do this in chapter 6. The outcome is that the $1/N$ expansion may be identified with a sum over branched covers - or simple generalizations of branched covers.

1.1.6. Interpreting the sum

The $1/N$ expansion gives a sum over branched covers - but how are the branched covers weighted? In chapter 7 we give the correct interpretation of the weights: they are topological invariants - Euler characters - of the moduli space of holomorphic maps from Riemann surfaces to Riemann surfaces [52].

1.1.7. The challenge

One of the first goals of Gross' program was to find a string action for YM_2 . The significance of the results of chapters 7 and 8 is that they provide the bridge between YM_2 and cohomological field theory.

Cohomological field theory, when described systematically, provides a machine by which one can associate a local quantum field theory to the study of intersection numbers in moduli spaces of solutions to differential equations.

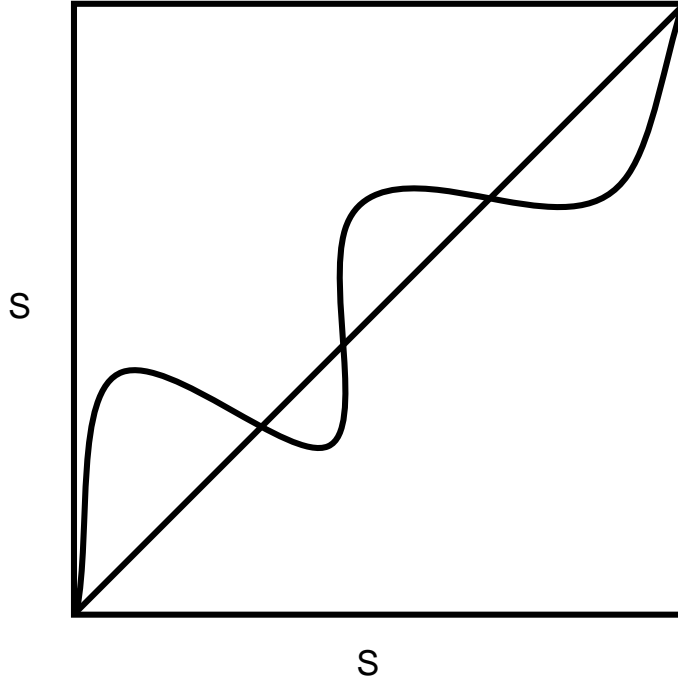

Fig. 1: Perturbed diagonal.

The relevance to the Euler characters, discovered in chapter 7, can be seen by recalling the following famous fact. Let S be a space, and consider S sitting along the diagonal of $S \times S$. If we perturb the diagonal as in fig. 1 then the intersection number is just $\chi(S)$.

The machinery is described in part II and applied in chapter 18 to write a string action for a string theory equivalent to YM_2 . This action should be useful for future computations and studies of YM_2 . Much more importantly, it has a natural generalization to *four*-dimensional target spaces. The significance of the four-dimensional theory is not yet known. Some guesses are described in chapter 20. The real challenge is two-fold:

- a.) Describe the target space physics of the theory in chapter 20.
- b.) Far more importantly: can we use the above results to say anything interesting about a string formulation of YM_4 ?

1.2. Related Topics not Discussed

There are many important topics related to the subject of these lectures which are not discussed. These include:

1. The incorporation of dynamical quarks and the 't Hooft model of D=2 QCD. Much work on this subject, including a derivation of the 't Hooft equation starting from a

Nambu-type string action, was carried out by I. Bars and collaborators in [21,22]. Recently there has been very interesting progress in relating this topic to a bilocal field theory with connections to W_∞ symmetry [181,58,20].

2. Kostov has written an interesting paper inspired by the results of Gross-Taylor but applying, in principle, to $D = 4$ Yang-Mills. This carries further an old program initiated by Kazakov, Kostov, O' Brien and Zuber, and Migdal [117,129,164,141].

3. In part II on topological field theory we have emphasized the construction of Lagrangians and BRST principles. Space does not permit a discussion of the very interesting canonical formulation of these theories, which involves Floer's symplectic and 3-manifold homology theories.

4. One issue of great importance in TFT is defining appropriate compactifications of moduli spaces. This is quite necessary for producing explicit, rather than formal, results. Space limitations preclude a discussion of these issues.

5. In recent years, many very beautiful explicit results for topological field theory correlators have been obtained, both in topological string theory and in topological gauge theory. For example, there are now explicit formulae for quantum cohomology rings and for Donaldson invariants. Again, space does not permit a discussion of these interesting results.¹

6. There are many other aspects of topological theories we have not entered upon. We also have not referenced many authors. Since 1988 there have been, literally, thousands of papers written on topological field theory. It is not possible to do justice to them all. We apologize to authors who feel their work has not been adequately cited.

1.3. Some related reviews

Some aspects of YM_2 are also reviewed in [120,18,21,97,71]. Cohomological field theory is also reviewed in [205,229,34]. Finally, the reader should note that some parts of this text have appeared in other places. Some of the text in chapters 5, 7, and section 18.6 has appeared in [52]. Parts of secs. 14.6,15.12.1, and 20 have appeared in [152].

¹ Quite recently (November, 1994) spectacular progress has been made in topological gauge theory. See [130,234,203].

2. Yang-Mills as a String Theory

2.1. Motivations for strings

The motivations for looking for a Yang-Mills string have been extensively discussed elsewhere. See [174,175,141,173,69] for some representative references. This is a contentious subject and has been under debate for over 25 years. Let us listen in briefly to a piece of this interminable argument between a visionary physicist/misguided mathematician and sensible realist/cynical reactionary².

enthusiast: Look, string amplitudes satisfy *approximate duality!* This is an experimental result and was, in fact, responsible for the very genesis of string theories in the late sixties!

skeptic: It is, unfortunately, difficult to proceed from these experimental results to the correct string version of Yang-Mills in anything other than a phenomenological approach.

enthusiast: But there is a second reason. Consider 't Hooft's planar diagrams! If we hold Ne^2 fixed, then the diagrams are weighted with N^χ where χ is the Euler character of a surface (in "index space") dual to the diagram! Thus we see the *emergence of surfaces in weak coupling, large N perturbation theory!* At large orders of perturbation theory we have "fishnet diagrams!" This is, of course, the connection between large N matrix theories and strings that has been so brilliantly exploited in the matrix model approach to low-dimensional string theories!

skeptic: Quite right, but what you see as a strength I regard as a weakness: The description of planar diagrams as surfaces is only clear at large order in perturbation theory. Many important physical properties are well-described by low orders of perturbation theory, and it is hard to see how an effective string description will help. How, for example, do you expect to see asymptotic freedom with strings, if strings only become effective at large orders of perturbation theory?

enthusiast: There is a third reason for suspecting a deep connection! The *natural* variables in Yang-Mills are the holonomy variables, or Wilson loops:

$$\Psi(C) = \langle W(C) \rangle$$

² We thank many colleagues, especially M. Douglas, for participating in such arguments.

Moreover, there is a very geometrical set of equations governing these quantities! These are the Migdal-Makeenko equations:

$$\begin{aligned} L\Psi &= g^2 \oint dx_\mu \oint dy_\mu \delta^4(x-y) \langle \text{Tr } W(C_{xy}) \rangle \langle \text{Tr } W(C_{yx}) \rangle (1 + \mathcal{O}(\frac{1}{N})) \\ &\sim g^2 \oint dx_\mu \oint dy_\mu \delta^4(x-y) \Psi(W(C_{xy})) \Psi(W(C_{yx})) (1 + \mathcal{O}(\frac{1}{N})) \end{aligned} \quad (2.1)$$

Here L is a kind of Laplacian on functions on the space of loops!

skeptic: But the loop variables are terribly hard to define. The above equations involve singular quantities, the Laplacian is a very delicate object, and it is not clear what kinds of boundary conditions you should specify. The renormalization of Wilson loops is notoriously difficult and any loop description of the Hilbert space will be highly nontrivial. Moreover, there are nontrivial issues of constraints on the wavefunctions and independence of variables that have to be sorted out.

enthusiast: But there is a fourth reason! Consider the strong-coupling expansion of lattice gauge theory

$$Z = e^{N^2 F} = \int \prod_{\ell} dU_{\ell} e^{N\beta \sum_p \text{Tr}(U_p + U_p^\dagger)} = \sum_{n \geq 0} \beta^n Z_n(N),$$

where ℓ runs over the links and p over the plaquettes. When calculating the terms in the expansion, we must contract plaquettes and hence we see the *emergence of surfaces in strong coupling perturbation theory!* For nonintersecting surfaces we literally have a sum over surfaces weighted by the Nambu action!

skeptic: Well, what you say is true if we consider nonintersecting surfaces. Then we may use:

$$\int dU (U^\dagger)_i^j U_l^k = \frac{1}{N} \delta_i^k \delta_l^j \quad (2.2)$$

But in the strong coupling expansion you will have much more complicated integrals. When a surface self-intersects you will need to weight these in complicated ways. The sum over surfaces will be so complicated as to be utterly useless.

enthusiast: That is not obvious: the basic integrals of U_{ij}, U_{ij}^\dagger have $1/N$ expansions so, at least formally, a series expansion exists. For example,

$$\begin{aligned} \int dU (U^\dagger)_{i_1}^{j_1} (U^\dagger)_{i_2}^{j_2} U_{l_1}^{k_1} U_{l_2}^{k_2} &= \frac{1}{N^2 - 1} [\delta_{i_1}^{k_1} \delta_{l_1}^{j_1} \delta_{i_2}^{k_2} \delta_{l_2}^{j_2} + PERMS] \\ &\quad - \frac{1}{N(N^2 - 1)} [\delta_{i_1}^{k_1} \delta_{j_1}^{l_2} \delta_{i_2}^{k_2} \delta_{j_2}^{l_1} + PERMS] \end{aligned} \quad (2.3)$$

The second term looks strange and contributes at leading order in $1/N$. Nevertheless, one of the beautiful achievements of [118,164] was to find a description of these $1/N$ expansions in terms of surfaces. Thus, the large N strong coupling expansion of Yang-Mills theory is a string theory!

skeptic: But there are more serious objections. You will have to connect to the weak coupling phase to see continuum physics. Indeed, your large N expansion will introduce further headaches. After taking the large N expansion it is quite possible that there will be a strong-weak phase transition which was not present at finite N . Indeed there are known examples of such phase transitions [98,72,96,119].

enthusiast: But it is not clear how generic these phase transitions are. Even if they exist it may be possible to calculate some important quantities!

skeptic: It is often said that strings automatically include gravity. Don't we expect general 4D strings to have gravitons and dilatons - thus ruling them out as candidates for QCD?

enthusiast: Not at all! There are topological strings with no propagating degrees of freedom. There are $N = 2$ strings [167] with a single scalar field as a propagating degree of freedom!

The debate continues, but it is time to move on.

2.2. The case of two dimensions

The issues debated in the previous section can be brought into much sharper focus in the context of $D = 2$ Yang-Mills theory. Here the loop variables advocated by our enthusiast can be defined. Indeed, we will do so in chapter 4. Moreover, as we will see in chapter 3, exact results for the amplitudes are available. D. Gross advocated that one should examine these exact results in the large N theory and search for “stringy” signatures of the coefficients in the $1/N$ expansion [91]. As we will see, Gross' program has enjoyed some degree of success.

2.2.1. What to look for

What should we look for to see a string formulation of YM_2 ? There are two basic aspects:

1. Hilbert space

As we learned in the above debate, the natural variables in a string description of Yang-Mills are the loop variables:

$$\prod_j (\text{Tr } U^j)^{k_j} \quad k_j \in \mathbb{Z}_+$$

where U is the holonomy around a loop. These may be considered as wavefunctions in a Hamiltonian treatment. We must relate these to a description in terms of $L^2(\mathcal{A}/\mathcal{G})$, where \mathcal{A} is the space of spatial gauge fields.

2. Amplitudes

The $1/N$ expansion of the partition function should have the general form:

$$Z(A, \Sigma_T) \sim \exp \left[\sum_{h \geq 0} \left(\frac{1}{N} \right)^{2h-2} Z_h(A, \Sigma_T) \right] \quad (2.4)$$

It is already nontrivial if only even powers of $1/N$ appear and $h \geq 0$. In chapter 6 below we will see that this is indeed true for the case of two dimensions. The coefficients of the $1/N$ expansion are to be interpreted in terms of sums over maps:

$$Z_h(A, \Sigma_T) = \int_{\mathcal{M}} d\mu \quad (2.5)$$

where $\mathcal{M} = \text{MAP}[\Sigma_W \rightarrow \Sigma_T]$ is some space of maps from a *worldsheet* Σ_W of genus h to the spacetime Σ_T of genus p . We similarly expect other quantities in the theory, e.g. expectation values of Wilson loops, to have similar expansions.

There are two central issues to resolve in making sense of (2.5):

- α . What class of maps should we sum over in \mathcal{M} ? The classification of maps $\Sigma_W \rightarrow \Sigma_T$ depends strongly on what category of maps we are working with.
- β . What is the measure $d\mu$? (Equivalently, what is the string action?)

The answer to question α is given in chapter 7. The answer to question β is given in chapter 18.

3. Exact Solution of Yang-Mills in Two Dimensions

3.1. Special features of two dimensions

Exact results in YM_2 have been developed over the past several years by many people, beginning with some work of A. Migdal [140]. One key feature of two dimensions is that

there are no propagating degrees of freedom – there are no gluons. This does not make the theory trivial, but does mean that we must investigate the theory on spacetimes of nontrivial topology or with Wilson loops to see degrees of freedom. Since there are so few degrees of freedom one might suspect that there is a very large group of local symmetries. Indeed, YM_2 has a much larger invariance group than just local gauge invariance \mathcal{G} - it is invariant under area preserving diffeomorphisms, $\text{SDiff}(\Sigma_T)$.

The area-preserving diffeomorphism invariance may be seen as follows: Once we have chosen a metric, G_{ij} , on Σ_T we can map the field strength F , which is a two form, to a Lie-algebra-valued scalar f :

$$f = *F \longleftrightarrow F = f\mu \quad (3.1)$$

where μ is an area form. In components:

$$F_{ij}^a = \sqrt{\det G_{ij}} \epsilon_{ij} f^a$$

In terms of f one may write the Yang-Mills action as:

$$I_{\text{YM}} = \frac{1}{4e^2} \int_{\Sigma_T} d^2x \sqrt{\det G_{ij}} \text{Tr} f^2 = \frac{1}{4e^2} \int_{\Sigma_T} \mu \text{Tr} f^2 \quad (3.2)$$

The quantity f is a scalar, hence, any *diffeomorphism* which preserves the volume element $d^2x \sqrt{\det G_{ij}}$ is a symmetry of the action. This makes it “almost” generally covariant, and this kills almost all the degrees of freedom.

3.2. A larger space of theories

Let us make several remarks on the theory (3.2):

- 3.2.1 We may rewrite the action as

$$I = -\frac{1}{2} \int i \text{Tr}(\phi F) + \frac{1}{2} e^2 \mu \text{Tr} \phi^2 \quad (3.3)$$

where ϕ is a Lie-algebra valued 0-form. From this we see that the gauge coupling e^2 and total area $a = \int \mu$ always enter together.

- 3.2.2 It is natural to generalize the action (3.3) to

$$I = \int \left[i \text{Tr}(\phi F) + \mathcal{U}(\phi) \mu \right] \quad (3.4)$$

where \mathcal{U} is any invariant function on the Lie algebra, $\underline{\mathfrak{g}}$ [226]. Thus, we should regard ordinary YM_2 as one example of a general class of theories parametrized by *invariant functions on $\underline{\mathfrak{g}}$* . It is natural to restrict to the ring of invariant polynomials on $\underline{\mathfrak{g}}$. Explicitly, for $G = SU(N)$, this ring may be described as a polynomial ring generated by $\text{Tr } \phi^k$, so we may describe the general theory by coordinates $t_{\vec{k}}$:

$$\mathcal{U} = \sum t_{\vec{k}} \prod_j (\text{Tr } \phi^j)^{k_j}$$

This is in marked contrast to the situation in $D = 4$ Yang-Mills where the only dimension four gauge invariant operators are $\text{Tr}(F \wedge *F)$ and $\text{Tr}(F^2)$, the latter being a topological term.

- 3.2.3. The action

$$I_{\text{top}} = -\frac{1}{2} \int i \text{Tr } (\phi F)$$

describes a topological field theory whose path integral is concentrated on flat connections $F = 0$. In the small area limit (or the $\mathcal{U} \rightarrow 0$ limit) we must reproduce the results of this topological field theory.

- 3.2.4. The situation in $D = 2$ naturally leads to the question of whether any information in $D = 4$ Yang-Mills can be extracted from topological Yang-Mills. At first this seems absurd given the obvious complexity of the physical theory. Nevertheless, there are indications that the situation is not hopeless. For example we may write the $D = 4$ action as [34]

$$\int \text{Tr } BF + e^2 \text{Tr } B \wedge *B \quad . \quad (3.5)$$

The first term gives a topological theory, although it has a much larger gauge invariance than the theory with $e^2 \neq 0$. A second relation between a topological and a physical theory is given by the twisting procedure described in chapter 15.

- 3.2.5. When comparing results in YM_2 with results from topology, it is important to remember that different definitions of the theory can differ by the local counterterms

$$\Delta I = k_1 \frac{1}{4\pi} \int R + k_2 e^2 \int \mu \quad (3.6)$$

leading to an overall ambiguous factor of $e^{-k_1(2-2p)-k_2e^2a}$ in the normalization of Z on a surface of genus p and area a [226].

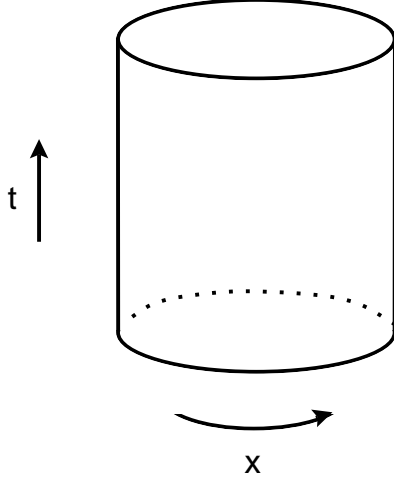

Fig. 2: Cylinder on which Yang-Mills is quantized.

3.3. Hilbert space

Consider quantizing the theory on a cylinder such as fig. 2 with periodic spatial coordinate x of period L . With the gauge choice $A_0 = 0$, we may characterize the Hilbert space as follows. The constraint obtained from varying A_0 in the Yang-Mills action (A.37) is

$$D_1 F_{10} = 0. \quad (3.7)$$

In canonical quantization we must impose the constraint (3.7) on wavefunctions $\Psi[A_1^a(x)]$. By using time-independent gauge transformations we can set $A_1^a = \text{const}$. Then demanding invariance under the remaining x -independent gauge transformations allows us to rotate to the Cartan subalgebra³. Finally, we demand invariance under the Weyl group. This gives a function on *Cartan/Weyl*.

Alternatively, the constraint (3.7) becomes an operator equation. Let T_a be an orthonormal (ON) basis of \mathfrak{g} , with structure constants $[T_a, T_b] = f_{ab}^c T_c$. Then the Gauss law constraint becomes:

$$\nabla \cdot E^a \Psi = \left(\partial_1 \frac{\delta}{\delta A_1^a(x)} + f_{bc}^a A_1^b(x) \frac{\delta}{\delta A_1^c(x)} \right) \Psi = 0 \quad (3.8)$$

³ Recall that a semi-simple Lie algebra \mathfrak{g} has a unique (up to conjugation) maximal abelian subalgebra called the Cartan subalgebra. The commutative group obtained by exponentiating the generators is a multi-dimensional torus called the Cartan torus or the maximal torus T . The Weyl group, W , is the group of outer automorphisms of $T \subset G$. W can be thought of as the set of $g \in G - T$ such that $gTg^{-1} = T$. For more details see, for example, [100,235].

which is solved by wavefunctionals of the form:

$$\Psi[A_1^a(x)] = \Psi \left[P \exp \left[\int_0^L dx A_1 \right] \right] \quad (3.9)$$

Demanding invariance under x -independent gauge transformations shows that Ψ only depends on the conjugacy class of $U = P \exp \int_0^L dx A_1$. From either point of view we conclude that [226,147]:

The Hilbert space of states is the space of L^2 -class functions on G .

The inner product will be

$$\langle f_1 | f_2 \rangle = \int_G dU f_1^*(U) f_2(U)$$

where dU is the Haar measure normalized to give volume one.

We now find a natural basis for the Hilbert space. By the Peter-Weyl theorem for G compact we can decompose $L^2(G)$ into the matrix elements of the unitary irreducible representations of G :

$$L^2(G) = \oplus_R R \otimes \bar{R}$$

Consequently a natural basis for the Hilbert space of states - the “representation basis” - is provided by the characters in the irreducible unitary representations. The states $|R\rangle$ have wavefunctions $\chi_R(U)$ defined by

$$\langle U | R \rangle \equiv \chi_R(U) \equiv \text{Tr}_R(U) \quad (3.10)$$

Let us now find the Hamiltonian for this theory. In the standard theory the Hamiltonian density is $\frac{e^2}{2}(E^2 + B^2)$, but $B = 0$ in $D = 2$ so $H = \frac{e^2}{2} \int dx \frac{\delta}{\delta A_1^a(x)} \frac{\delta}{\delta A_1^a(x)}$. Acting on functionals of the form (3.9) we may replace $H \rightarrow \frac{1}{2} e^2 L \text{Tr}(U \frac{\partial}{\partial U})^2$. Now the conjugate momentum $\pi_{A_1^a} = \frac{\delta}{\delta A_1^a}$ acting on the wavefunctions $\chi_R(U)$ is given by

$$\pi_{A_1^a} \chi_R(U) = \chi_R(T^a U) \quad (3.11)$$

Since $\sum_a T^a T^a$ evaluated in representation R is $C_2(R)$, the eigenvalue of the quadratic Casimir in representation R , it follows that

The Hamiltonian is diagonalized in the representation basis and is the quadratic Casimir: $H = \frac{e^2}{2} LC_2(R)$.

Even in the generalized theories of section 3.2, the Hamiltonian is diagonal in the representation basis. The action of the invariant polynomials on $|R\rangle$ is described by polynomials in the Casimir operators $C_k(R)$. Explicitly, the Hamiltonian for the general theory can be parametrized by

$$H = \sum_{\vec{k}} \tau_{\vec{k}} \prod_j (C_j(R))^{k_j} \quad (3.12)$$

Calculating the change of variables $t \rightarrow \tau$ involves resolving ordering ambiguities. The coordinates carry a degree associated with the degree in the polynomial ring. The transformation is upper triangular in terms of this degree. For example, a perturbation by $t_k \text{Tr} \phi^k$ perturbs the Hamiltonian by Casimirs of degree less than or equal to k .

Exercise. Research problem

Consider YM_2 for the noncompact gauge group $SL(N, \mathbb{R})$. How do the above statements generalize?

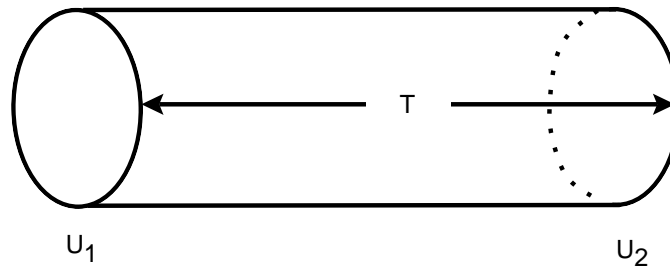

Fig. 3: Propagator of Yang-Mills.

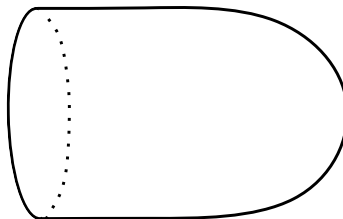

Fig. 4: Wavefunction for disk.

3.4. Exact results for amplitudes

We review results of [140,45,117,99,187,79,195,38,226,84].

3.4.1. Basic Amplitudes

1. Cylinder amplitude. Having diagonalized the Hamiltonian, we can immediately write the propagator corresponding to fig. 3:

$$Z(T, U_1, U_2) = \sum_R \chi_R(U_1) \chi_R(U_2^\dagger) e^{-\frac{e^2}{2} L T C_2(R)} \quad (3.13)$$

which is just the heat kernel on the group. Note that the combination $\frac{e^2}{2} L T = \frac{e^2}{2} a$ enters together, as predicted by $\text{SDiff}(\Sigma)$ invariance. In the rest of this chapter we absorb $\frac{e^2}{2}$ into a . For the generalized theories with H given in (3.12) we simply replace $a C_2(R) \rightarrow a \sum \tau_{\vec{k}} \prod (C_j)^{k_j}$.

Exercise. *Gluing property*

Using the orthogonality relations of characters prove the gluing property:

$$\int dU Z(T_1, U_1, U) Z(T_2, U, U_2) = Z(T_1 + T_2, U_1, U_2) \quad (3.14)$$

2. Cap amplitude, disk amplitude. By the gluing property of the propagator it suffices to calculate the amplitude for the disk in the limit of zero area. At area = 0 the disk amplitude can be calculated in the topological theory, where $\mathcal{U} = 0$. Integrating out ϕ sets $F = 0$. Now the wavefunction $\Psi(U)$, where U is the holonomy around the boundary of the disk, is supported on holonomies of flat connections on the disk, which forces $U = 1$:

$$\Psi(U) = \delta(U, 1), \quad (3.15)$$

where δ is the delta function in the Haar measure.

Gluing the infinitesimal cap to the cylinder and using (3.13) we find the disk amplitude for a disk of area a , fig. 4:

$$Z(a, U) = \sum_R \dim R \chi_R(U) e^{-a C_2(R)} \quad (3.16)$$

Using the area-preserving diffeomorphism invariance we may flatten out the disk and regard (3.16) as an amplitude for a plaquette. Indeed this is true for any piece of surface diffeomorphic to the disk.

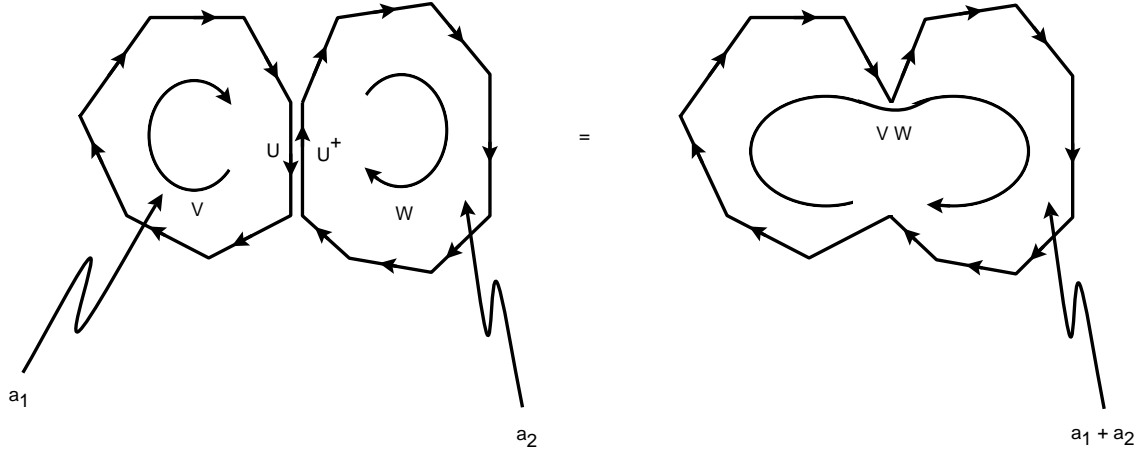

Fig. 5: Integrating out a link leaves the partition function invariant.

3.4.2. RG Invariance

Now we can compute the amplitudes for more complicated surfaces by standard gluing techniques familiar from “axiomatic topological field theory.”

The gluing rules are based on the fundamental identity:

$$\int dU \chi_{R_1}(VU)\chi_{R_2}(U^\dagger W) = \delta_{R_1, R_2} \frac{\chi_{R_1}(VW)}{\dim R_1} \quad (3.17)$$

which follows from the orthogonality relations for group matrix elements. This allows us to glue together disconnected plaquettes. Suppose that two regions \mathcal{R}_1 and \mathcal{R}_2 share a common arc \mathcal{I} . Let U denote $P \exp \int_{\mathcal{I}} A$ along \mathcal{I} . We can glue these two as in fig. 5:

In formulae we have

$$\int dU Z(a_1, VU)Z(a_2, U^\dagger W) = Z(a_1 + a_2, VW) \quad (3.18)$$

We can interpret this as RG invariance of the basic plaquette Boltzman weight. If we tried to write the lattice theory with this weight on the plaquettes, we would produce the exact answer. Taking the continuum theory is trivial!

Exercise. Research problem

Since the partition function has an exact expression on triangulated surfaces, it should be possible to simulate fluctuating geometry on the spacetime Σ_T , using, for example, matrix model techniques. Investigate the behavior of YM_2 coupled to 2D quantum gravity. What are the amplitudes? Is this theory a string theory?

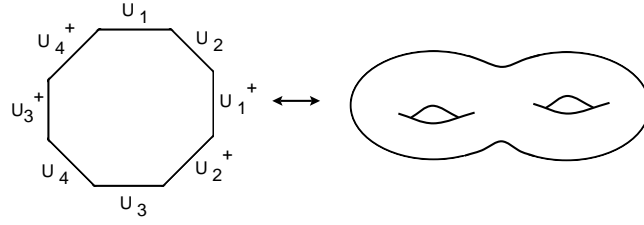

Fig. 6: Opening up a genus two surface.

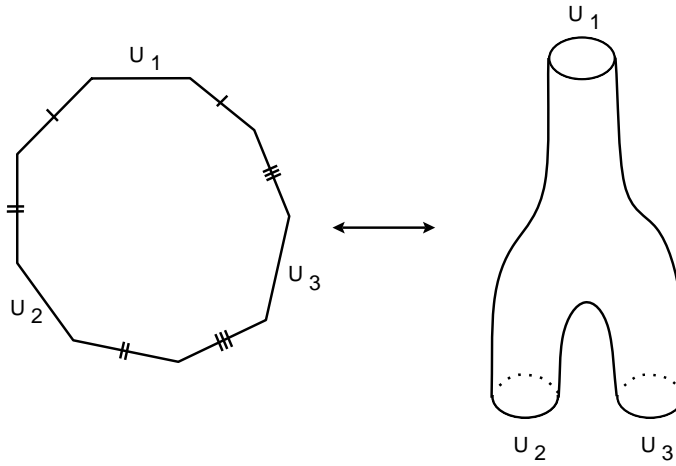

Fig. 7: Decomposition of a pants diagram.

3.4.3. Surfaces with nontrivial topology

To get more complicated topologies we must glue pieces of the same boundary to itself. We can do that using the identity

$$\int dU \chi_R(UVU^\dagger W) = \frac{\chi_R(V)\chi_R(W)}{\dim R} \quad (3.19)$$

which follows from (3.17). It is a straightforward exercise at this point to derive exact relations for amplitudes:

Exercise. *Partition functions*

As an application of this remark let us decompose a surface Σ_T of genus p as a $4p$ -sided polygon as in fig. 6. By applying (3.19) repeatedly, derive the famous result:

$$Z(\Sigma_T, p, a) = \sum_R (\dim R)^{2-2p} e^{-aC_2(R)} \quad (3.20)$$

for a closed oriented surface Σ_T of genus p and area a .

Exercise. *3-holed sphere*

- a.) Represent the 3-holed sphere with boundary holonomies U_1, U_2 and U_3 as a 9-sided figure with 3 sides pairwise identified as in fig. 7. Using (3.19) show that

$$Z(U_1, U_2, U_3; a) = \sum_R \frac{\chi_R(U_1)\chi_R(U_2)\chi_R(U_3)}{\dim R} e^{-aC_2(R)} \quad (3.21)$$

- b.) Dividing the surface Σ_T up into pants, use (3.21) to rederive (3.20).
-

Exercise. *General surface with boundary*

Generalize the result of the previous exercise to derive the amplitude for a connected surface with p handles and b boundaries. Suppose the boundaries carry holonomy U_i . Show that

$$Z(\Sigma_T, p; U_1, \dots, U_b; a) = \sum_R (\dim R)^{2-2p-b} e^{-aC_2(R)} \prod_{i=1}^b \chi_R(U_i) \quad (3.22)$$

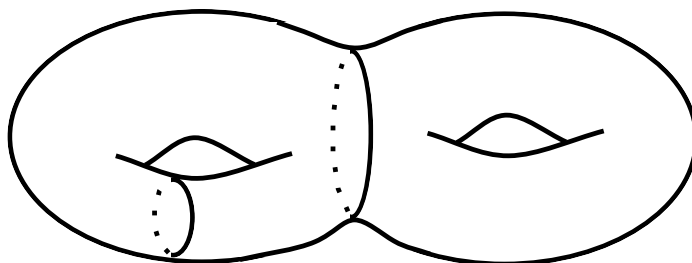

Fig. 8: Two non-intersecting Wilson loops.

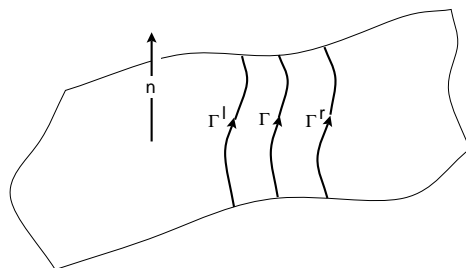

Fig. 9: Using the orientation of the surface and of the Wilson line we can define two infinitesimal deformations of the Wilson line $\Gamma^{l,r}$.

3.5. Exact Wilson loop averages

3.5.1. Nonintersecting loops

Suppose that we have a collection $\{\Gamma\}$ of curves in Σ_T , as in fig. 8. Let

$$\Sigma_T - \amalg \Gamma = \amalg_c \Sigma_T^c \quad (3.23)$$

be the decomposition into disjoint connected components. Each component Σ_T^c has p_c handles, b_c boundaries and area a_c . Since Σ_T and Γ are each oriented, each curve Γ can be deformed into two curves $\Gamma^{l,r}$ as in fig. 9. We let $c_\Gamma^{l,r}$ denote the label of the component Σ_T^c which contains $\Gamma^{l,r}$. Associated to each curve Γ we have a representation R_Γ and a Wilson loop operator:

$$W(R_\Gamma, \Gamma) \equiv \text{Tr}_{R_\Gamma} P \exp \oint_\Gamma A \quad . \quad (3.24)$$

The exact answer for correlation functions of Wilson loops is given by integrating the amplitude for the surface with boundary against the Wilson loop operators:

$$\left\langle \prod_\Gamma W(R_\Gamma, \Gamma) \right\rangle = \int \prod_\Gamma dU_\Gamma \prod_c Z(\Sigma_T^c; U_{c_\Gamma^l=c}, U_{c_\Gamma^r=c}^\dagger) \prod_\Gamma W(R_\Gamma, \Gamma) \quad (3.25)$$

where in the second product above we include those boundary holonomies $U_{c_\Gamma^l}$ with Γ such that $c_\Gamma^l = c$. Now we use the identity

$$\int dU \chi_{R_1}(U) \chi_{R_2}(U) \chi_{R_3}(U^\dagger) = N^{R_3}_{R_1, R_2}, \quad (3.26)$$

where $N^{R_3}_{R_1, R_2}$ are the ‘‘fusion numbers’’ defined by the decomposition of a tensor product into irreducible representations

$$R_1 \otimes R_2 = \oplus_{R_3} N^{R_3}_{R_1, R_2} R_3 \quad . \quad (3.27)$$

Applying this identity to each boundary leads to

$$\left\langle \prod_\Gamma W(R_\Gamma, \Gamma) \right\rangle = \sum_{R(c)} \prod_c (\dim R(c))^{\chi(\Sigma_T^c)} e^{-a_c C_2(R(c))} \prod_\Gamma N^{R(c_\Gamma^r)}_{R(c_\Gamma^l), R_\Gamma} \quad (3.28)$$

where we sum over unitary irreps, $R(c)$, for each component c , and a_c denote the areas of the components Σ_T^c .

3.5.2. Intersecting loops

Expectation values of insertions of $\chi_{R_\Gamma}(U_\Gamma^\dagger)$ for intersecting Wilson loops Γ , around which the holonomy is U_Γ , can be dealt with in a similar way [226,187]. We cut the Σ_T along the Wilson lines separating it into several regions labeled by c with areas a_c , and p_c handles inside, as in (3.23). The Wilson average contains a local factor for each component

$$Z_c = \sum_{R_c} \dim R_c e^{-a_c C_2(R_c)/2} \prod_{i=1}^{b_c} \chi_{R_c}(U_c^{(i)}) \quad (3.29)$$

where $U_c^{(i)}$ is the holonomy of the gauge field around the i 'th boundary of region c . The Wilson average can be written as:

$$\sum_{R_c} \int \prod_E dU_E \prod_c Z_c \prod_\Gamma \chi_{R_\Gamma}(U_\Gamma^\dagger). \quad (3.30)$$

The integral is over all the edge variables U_E .

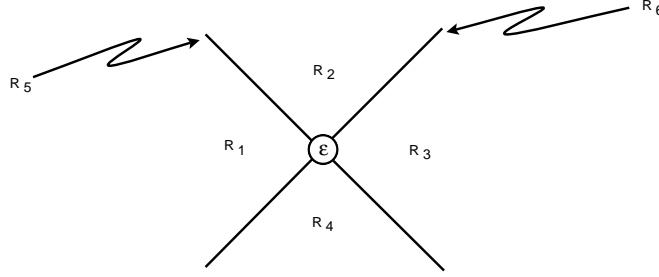

Fig. 10: Representations near an intersection of Wilson loops.

The group variable appears three times, from the Wilson line insertion in the representation R , and from the two regions R_a and R_b on either side of the edge. The group integral gives a Clebsch-Gordan coefficient for R_b in $R_a \otimes R$. These Clebsch-Gordan coefficients can be collected into factors associated with each vertex. After summing all the factors associated with a given vertex we are left with a $6j$ symbol where the 6 representations⁴ in question belong to the two Wilson lines and the four regions neighboring the vertex

$$W = \prod_c \sum_{R_c} \sum_{\epsilon_\gamma} (\dim R_c)^{2-2p_c-b_c} e^{-a_c C_2(R_c)/2} \prod_v G_v(R_c; R_\Gamma; \epsilon_\gamma) \quad (3.31)$$

The index v runs over the vertices and the index ϵ_γ runs over a basis for the vector space of intertwiners between $R_a \otimes R$ and R_b .

⁴ We will abbreviate the words ‘representation’ and ‘representations’ by ‘rep’ and ‘reps.’

3.6. YM_2 and topological field theory

3.6.1. $e^2 = 0$ and Flat Connections

Later on we will discuss at length the relation of YM_2 to topological string theory. Here we sketch briefly some other relations to topological field theories.

At $e^2 = 0$, (3.2) becomes a simple “BF-type” topological field theory [34] with action

$$I = \frac{i}{4\pi^2} \int_{\Sigma_T} \text{Tr}(\phi F). \quad (3.32)$$

Evidently, ϕ acts as a Lagrange multiplier setting $F(A) = 0$, so we expect the theory to be closely connected with the geometry of the moduli space of *flat* connections. This is defined to be the space

$$\mathcal{M}(F = 0; \Sigma_T, P) = \{A \in \mathcal{A}(P) | F(A) = 0\} / \mathcal{G}(P) \quad (3.33)$$

where $P \rightarrow \Sigma_T$ is a principal G bundle, and the remaining notation is defined in section A.5. This space is far from trivial. A flat connection may be characterized by its holonomies around the various generators of the homotopy group $\pi_1(\Sigma_T)$:

$$\mathcal{M}(F = 0; \Sigma_T, P) = \text{Hom}(\pi_1(\Sigma_T), G) / G \quad (3.34)$$

This description makes clear that it is a manifold ⁵ of dimension $\dim G (2p - 2)$. In order to derive the measure on \mathcal{M} given by the path integral one must gauge fix á la Faddeev-Popov. The resulting path integral - as for all BF theories [190,34] reduces to a ratio of determinants known as Ray-Singer torsion. Careful implementation of these considerations [226] shows that for gauge group $SU(N)$ we get the symplectic volume of \mathcal{M}

$$Z = \frac{1}{N} \int_{\mathcal{M}} \frac{\omega^n}{n!} = \frac{1}{N} \text{vol}(\mathcal{M}) \quad (3.35)$$

where ω is the symplectic form on \mathcal{M} arising from the symplectic form on $\mathcal{A}(P)$:

$$\omega(\delta A_1, \delta A_2) = \frac{1}{4\pi^2} \int_{\Sigma} \text{Tr}(\delta A_1 \wedge \delta A_2) \quad . \quad (3.36)$$

Somewhat surprisingly, at $e^2 \neq 0$ the path integral still contains information about the topology of \mathcal{M} . This requires the “nonabelian localization theorem” [227,123], and will be described in chapter 15 after we have discussed equivariant cohomology.

⁵ With singularities, due to the reducible connections. (See section 15.7.)

3.6.2. Chern-Simons theory and RCFT

The relation of $e^2 = 0$ YM_2 to the space of flat connections (3.33) provides a direct link to 3D Chern-Simons theory, and thereby [222] to rational conformal field theory. Indeed, as emphasized in [226], the formula for Z , equation (3.20), may be thought of as the large k limit of the Verlinde formula [210] for the number of $SU(N)$ level k conformal blocks on Σ

$$\sum_R \left(\frac{S_{00}}{S_{R0}} \right)^{2p-2} \quad (3.37)$$

Similarly, (3.21) is the limit of Verlinde's formula for the fusion rules

$$N_{R_1 R_2 R_3} = \sum_R \frac{S_{RR_1} S_{RR_2} S_{RR_3}}{S_{R0}} \quad (3.38)$$

Here $S_{R_1 R_2}$ is the “modular transformation matrix” between representations R_1 and R_2 (0 refers to the trivial representation). The connection arises since, at $k \rightarrow \infty$, $\frac{S_{R0}}{S_{00}} \rightarrow \dim R$ while $S_{R_1 R_2}$ becomes a matrix proportional to $\chi_{R_1}(U_2)$ where U_2 is related to R_2 by a map from representations to conjugacy classes of $G = SU(N)$. The formula (3.38) was proven, at finite k , using methods of conformal field theory, in [153].

3.7. Axiomatic Approach

It is possible to give simple axioms, analogous to those given by G. Segal and M. Atiyah for conformal field theory and for topological field theory, respectively, [193,15] for YM_2 . The geometric category has as objects collections of oriented circles. Morphisms are oriented surfaces with area, cobordant between the circles. The orientation agrees for the source and disagrees for the target.

To each circle we assign the Hilbert space of class functions on the gauge group G . To each surface we have a map of the ingoing Hilbert spaces to the outgoing Hilbert space. This map is defined by gluing and by the basic amplitudes

$$\begin{aligned} \text{Tube} &= \sum_R |R\rangle\langle R| e^{-aC_2(R)} \\ \text{Pants} &= \sum_R |R\rangle \otimes |R\rangle \otimes |R\rangle \frac{e^{-aC_2(R)}}{\dim R} . \end{aligned}$$

4. From YM_2 to Strings: The Canonical Approach

In this chapter we relate the Hilbert space of class functions to some simple conformal field theories. The main goal is to show how bosonization leads to a natural interpretation of the Hilbert space in terms of string states.

We would like to make some kind of sense of

$$\lim_{N \rightarrow \infty} \mathcal{H}_{SU(N)}. \quad (4.1)$$

It turns out that the best way to do this is to reformulate the Hilbert space in terms of free fermions.

4.1. Representation theory and Free Fermions

Many aspects of representation theory have a natural description in terms of quantum field theory of free fermions. The utility of this point of view has been emphasized by M. Douglas, and by J. Minahan and A. Polychronakos [147,68]. We will be following [68].

We have seen above that the Hamiltonian is the quadratic Casimir and that the Hilbert space is the space of L^2 class functions. Let us start with the group $G = U(N)$. Class functions are determined by their values on the maximal torus. We parametrize elements of the maximal torus $\Lambda \in T$ by

$$\Lambda = \text{Diag}\{z_1, \dots, z_N\} = \text{Diag}\{e^{i\theta_1}, \dots, e^{i\theta_N}\} \quad (4.2)$$

The Weyl group is the permutation group S_N , and conjugation by the Weyl group on T permutes the z_i . Hence class functions $\psi(\vec{\theta})$ are symmetric.

The inner product on class functions is given by the measure

$$(\psi, \psi) = \frac{1}{N!(2\pi)^N} \int \prod d\theta_i \tilde{\Delta}(\vec{z})^2 |\psi(\vec{\theta})|^2$$

where $\tilde{\Delta}(\vec{z}) = \prod_{i < j} \sin \frac{\theta_i - \theta_j}{2} = \frac{1}{(2i)^{\frac{N(N-1)}{2}}} \Delta(\vec{z}) / \prod_i z_i^{(N-1)/2}$, and $\Delta(\vec{z}) = \prod_{i < j} (z_i - z_j)$.

Moreover, when acting on class functions the Hamiltonian may be written, after a nontrivial calculation, as:

$$H = \frac{e^2}{2} \frac{1}{\tilde{\Delta}(\vec{z})} \left[\sum_i \left(-\frac{d^2}{d\theta_i^2} \right) - N(N^2 - 1)/12 \right] \tilde{\Delta}(\vec{z}) \quad (4.3)$$

Both the measure and the Hamiltonian suggest that it is better to work with a totally antisymmetric wavefunction $\psi \rightarrow \tilde{\Delta}(\vec{z})\psi$ with a standard measure and $H = \sum_{i=1}^N p_i^2$. We

are simply describing a theory of N noninteracting fermions on the circle $0 \leq \theta \leq 2\pi$. The one-body wavefunctions are $z^n = e^{in\theta}$ for $n \in \mathbf{Z}$. The Hamiltonian, and all the higher Casimirs, are diagonalized by the Slater determinants:

$$\psi_{\vec{n}}(\vec{z}) = \det_{1 \leq i, j \leq N} z_i^{n_j} \quad (4.4)$$

so we will identify states $|R\rangle$ with these Slater determinant states.

The state (4.4) has energy $E = \sum_i n_i^2 - N(N^2 - 1)/12$. Under the $U(1)$ corresponding to matrices proportional to 1 the state has $U(1)$ charge $Q = \sum n_i$. Since the wavefunction vanishes unless all n_i are different, we may assume, without loss of generality, that $n_1 > n_2 > \dots > n_N$. We may recover the character of the rep corresponding to the the Fermi wavefunction (4.4) by dividing by $\tilde{\Delta}(\vec{z})$. This gives the Weyl character formula:

$$\chi_{\vec{n}}(\vec{z}) = \frac{\det_{1 \leq i, j \leq N} z_i^{n_j}}{\det_{1 \leq i, j \leq N} z_i^{j-1-n_F}} = \frac{\det_{1 \leq i, j \leq N} z_i^{n_j+n_F}}{\det_{1 \leq i, j \leq N} z_i^{j-1}}. \quad (4.5)$$

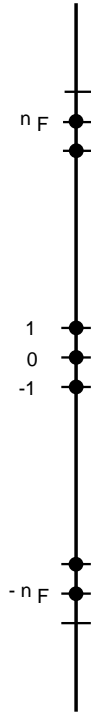

Fig. 11: The filled Fermi sea

The trivial rep corresponds to the ground state with $E = Q = 0$, with all levels filled from $-n_F$ to n_F , where $n_F = (N - 1)/2$. (See fig. 11) ⁶

The above considerations can also be applied to $SU(N)$ rep theory by imposing the constraint $\prod z_i = 1$. As an $SU(N)$ character we are free to shift all the n_i by any integer a .

4.2. $SU(N)$ and $U(N)$

$U(N)$ and $SU(N)$ reps are easily related by considering

$$1 \rightarrow \mathbf{Z}_N \rightarrow SU(N) \times U(1) \rightarrow U(N) \rightarrow 1 \quad . \quad (4.6)$$

So

$$U(N) = \frac{SU(N) \times U(1)}{\mathbf{Z}_N}.$$

We may therefore label irreducible $U(N)$ reps by a pair (R, Q) where R is an irrep of $SU(N)$. The irreps of $SU(N)$ are in turn labeled by Young diagrams⁷, Y . Since the kernel of (4.6) is represented trivially, the only pairs that occur are $(Y, Q = N\ell + n)$ where $Y \in \mathcal{Y}_n^{(N)}$. We will let \mathcal{Y}_n stand for the set of Young diagrams of n boxes, and $\mathcal{Y}_n^{(N)}$ stand for the set of diagrams with $\leq N$ rows. When the row lengths are specified we write $Y(h_1, \dots, h_r)$.

Given a state $\chi_{\vec{n}}$, we may describe the corresponding Young diagram as follows. Using the freedom to shift $n_i \rightarrow n_i + a$ we may arrange that $n_N = -n_F$. Then the Young diagram corresponding to the fermion state is $Y = Y(h_1, h_2, \dots, h_N)$ where

$$h_j = n_j + j - 1 - n_F \quad (4.7)$$

denotes the number of boxes in the j^{th} row. Note that $Q = \sum h_j$.

The Hamiltonian for the $SU(N)$ theory is

$$H_{SU(N)} = H_{U(N)} - Q^2/N \quad .$$

⁶ Assume for simplicity that N is odd.

⁷ See, for example, [100,235] for a discussion of this.

4.3. Second Quantization

It is natural to introduce a second-quantized formalism. B_{-n}^+ creates a mode with wavefunction z^n , B_n annihilates it, so we introduce:

$$\begin{aligned}\Psi(\theta) &= \sum_{n \in \mathbb{Z}} B_n e^{in\theta} \\ \Psi^\dagger(\theta) &= \sum_{n \in \mathbb{Z}} B_{-n}^+ e^{-in\theta}.\end{aligned}\tag{4.8}$$

The filled Fermi sea satisfies the constraints:

$$\begin{aligned}B_n|0\rangle &= 0, & |n| > n_F \\ B_{-n}^+|0\rangle &= 0, & |n| \leq n_F.\end{aligned}\tag{4.9}$$

Translation of operators from first to second quantization is standard. An important example for us is the following. Class functions act, by multiplication, as operators on the Hilbert space. The corresponding second quantized operators are given by:

$$\Upsilon_n = \sum z_i^n \quad \longleftrightarrow \quad \int d\theta \Psi^\dagger(\theta) e^{in\theta} \Psi(\theta).\tag{4.10}$$

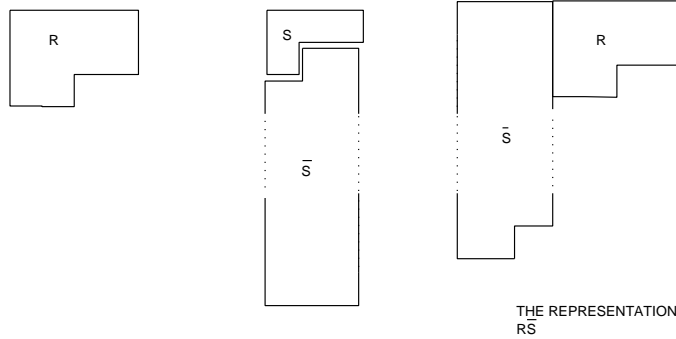

Fig. 12: Young diagram for a coupled rep. Given two reps R and S , for \bar{S} as indicated in the second diagram, form $R\bar{S}$ as indicated in the third diagram.

4.4. Large N Limit: Map to CFT

4.4.1. Chiral, Antichiral and Coupled Reps

Now we describe a formulation of the large N limit (4.1). The description is based on the idea that in the large N limit, the filled Fermi sea, corresponding to the trivial rep, has two Fermi levels which are “far” from each other.

This notion of the levels being far can be made a little more precise. We would like to consider states which, in the fermionic language, involve excitations around the Fermi sea involving changes of level numbers Δn_j which are small compared to N . In terms of reps, we characterize these states as follows. Let V be the fundamental rep, and \bar{V} its complex conjugate. Consider states contained in tensor products of small (with respect to N) numbers of V 's and \bar{V} 's. Intuitively, we have two decoupled systems corresponding to excitations around the two Fermi levels. They are decoupled, because we only consider small excitations. Thus we expect that the large N limit of the Hilbert space of class functions on $SU(N)$ should naturally be thought of as a tensor product:

$$\mathcal{H}_{SU(N)} \rightarrow \mathcal{H}_{\text{chiral}} \otimes \mathcal{H}_{\text{antichiral}}. \quad (4.11)$$

In terms of reps, the states we are talking about are the following: A collection of particles and holes around n_F corresponds to a rep $Y(h_1, \dots, h_N)$ described by (4.7). Evidently, we can describe the chiral Hilbert space formally as

$$\mathcal{H}_{\text{chiral}} = \bigoplus_{n \geq 0} \bigoplus_{Y \in \mathcal{Y}_n} \mathbb{C} \cdot |Y\rangle. \quad (4.12)$$

If we reflect around $n = 0$ we obtain a collection of particles and holes around $-n_F$. This state will correspond to the conjugate rep \bar{R} .

A subtle point arises when we consider states corresponding to excitations around both Fermi levels. If the excitations around the levels $n_F, -n_F$ correspond to reps R and \bar{S} , respectively, then the Slater determinant with both excitations present corresponds to the *irreducible* rep $R\bar{S}$, which is defined to be the largest irreducible rep in the decomposition of the tensor product $R \otimes \bar{S}$. When the numbers of boxes in $Y(R)$ and $Y(S)$ are much smaller than N , this definition is unambiguous. The reps $R\bar{S}$ were called ‘‘coupled reps’’ by Gross and Taylor [94]. The construction is illustrated in terms of Young diagrams in fig. 12.

4.4.2. Mapping to CFT

When we have decoupled systems it is appropriate to define two independent sets of Fermi fields:

$$\begin{aligned} \Psi(\theta) &= e^{i(n_F + \frac{1}{2})\theta} b(\theta) + e^{-i(n_F + \frac{1}{2})\theta} \bar{b}(\theta) \\ \Psi^\dagger(\theta) &= e^{-i(n_F + \frac{1}{2})\theta} c(\theta) + e^{i(n_F + \frac{1}{2})\theta} \bar{c}(\theta). \end{aligned} \quad (4.13)$$

We introduce complex coordinates $z = e^{i\theta}$, and define the mode expansions:

$$\begin{aligned}
b(z) &= \sum_{n \in \mathbb{Z} + \frac{1}{2}} b_n z^n \\
c(z) &= \sum_{n \in \mathbb{Z} + \frac{1}{2}} c_n z^n \\
\bar{b}(z) &= \sum_{n \in \mathbb{Z} + \frac{1}{2}} \bar{b}_n \bar{z}^n \\
\bar{c}(z) &= \sum_{n \in \mathbb{Z} + \frac{1}{2}} \bar{c}_n \bar{z}^n
\end{aligned} \tag{4.14}$$

$b_n, c_n, \bar{b}_n, \bar{c}_n$ are only unambiguously defined for $|n| \ll N$, so (4.13) only acts on the states in (4.11). The peculiar half-integral moding is chosen to agree with standard conventions in CFT. In terms of the original nonrelativistic modes we have:

$$\begin{aligned}
c_n &= B_{-n_F - \epsilon + n}^+ \\
b_n &= B_{n_F + \epsilon + n} \\
\bar{c}_n &= B_{n_F + \epsilon - n}^+ \\
\bar{b}_n &= B_{-n_F - \epsilon - n}
\end{aligned} \tag{4.15}$$

where $\epsilon = \frac{1}{2}$, so that

$$\{b_n, c_m\} = \delta_{n+m,0} \quad \{\bar{b}_n, \bar{c}_m\} = \delta_{n+m,0} \tag{4.16}$$

and all other anticommutators equal zero.

We may now reinterpret the fields b, c, \dots . Defining $z = e^{i\theta + \tau}$ we see that these may be extended to fields in two-dimensions, and that they are (anti-) chiral, that is, they satisfy the two-dimensional Dirac equation. We are thus discussing two relativistic massless Fermi fields in 1 + 1 dimensions. In this description the trivial rep is the product of vacua $|0\rangle_{bc} \otimes |\bar{0}\rangle_{\bar{b}\bar{c}}$ where $b_n |0\rangle_{bc} = c_n |0\rangle_{bc} = 0$ for $n > 0$. The spaces in (4.11) may be related to the CFT statespaces

$$\mathcal{H}_{bc} = \text{Span} \left\{ \prod b_{n_i} \prod c_{m_i} |0\rangle_{bc} \right\} . \tag{4.17}$$

The space \mathcal{H}_{bc} has a natural grading according to the eigenvalue of $\sum_{n \in \mathbb{Z}} : b_n c_{-n} = \mathcal{J} bc$ (called “ bc -number”):

$$\mathcal{H}_{bc} = \bigoplus_{p \in \mathbb{Z}} \mathcal{H}_{bc}^{(p)} \tag{4.18}$$

and we may identify:

$$\mathcal{H}_{\text{chiral}} = \mathcal{H}_{bc}^{(0)} \quad (4.19)$$

Indeed, in this language the class function corresponding to a rep with a Young diagram $|Y\rangle \in \mathcal{H}_{\text{chiral}}$ may be mapped to a corresponding fermionic bc state using (4.7) and then (4.15). The result is:

$$|Y(h_1, \dots, h_N)\rangle \leftrightarrow c_{-h_1+1-\frac{1}{2}} \cdots c_{-h_s+s-\frac{1}{2}} b_{-v_1+1-\frac{1}{2}} \cdots b_{-v_s+s-\frac{1}{2}} |0\rangle \quad (4.20)$$

where h_i are the row-lengths, v_i are the column lengths, and s is the number of boxes along the leading diagonal. Similarly, reps made from \bar{n} tensor products of \bar{V} would be described in terms of \bar{c} and \bar{b} . As long as $n, \bar{n} \ll N$ there is no ambiguity in this description.

The following is a quick argument to justify (4.20). For excitations of the free fermion system corresponding to particles created at levels a_i above the Fermi level and holes at levels $-b_i$ below n_F , the energy is

$$E = \sum_{i=1}^s [(n_F + a_i)^2 - (n_F - b_i)^2], \quad (4.21)$$

where s is the number of particles. Now using the following identity about Young diagrams (for this identity and generalisations see [112]) :

$$\sum_{i=1}^{v_1} (h_i - i)^2 = \sum_{i=1}^{s'} (h_i - i)^2 - (v_i - i + 1)^2 + \sum_{i=1}^{v_1} i^2 \quad (4.22)$$

where s' is the number of boxes along the leading diagonal, and v_i is the number of columns in the i 'th row, we find that the quadratic Casimir (energy) can be written in the form (4.21) if we make the identification $a_i = h_i - i + 1$, $b_i = v_i - i$ and $s = s'$. Translating this into modes, we get (4.20).

One very useful aspect of the introduction of b and c is that this system is a simple example of a conformal field theory, as will be discussed at length by Polchinski at this school. We simply note that if we introduce

$$L_n = \sum_{m=-\infty}^{\infty} (n/2 + m)c_{-m}b_{m+n} \quad (4.23)$$

then the L_n satisfy the Virasoro algebra

$$[L_n, L_m] = (n - m)L_{n+m} + \frac{c}{12}n(n^2 - 1)\delta_{n+m,0} \quad (4.24)$$

with $c = 1$.

Some aspects of large N group theory have very natural CFT formulations. For example, the $U(1)$ charge is:

$$\begin{aligned}
Q &= \int d\theta \Psi^+ \left(-i \frac{d}{d\theta}\right) \Psi = \sum_n n B_{-n}^+ B_n \\
&\rightarrow \sum_n n c_{-n} b_n - \sum_n n \bar{c}_{-n} \bar{b}_n \\
&= L_0 - \bar{L}_0.
\end{aligned} \tag{4.25}$$

In the second line we have assumed that the operator is acting on states so that the expression is unambiguous.

Remark: In the $U(N)$ theory we expect to get

$$\mathcal{H}_{U(N)} \rightarrow \oplus_p \mathcal{H}_{bc}^{(p)} \otimes \mathcal{H}_{\bar{b}\bar{c}}^{(-p)}. \tag{4.26}$$

4.5. Bosonization

The most important application of the CFT interpretation is to bosonization of the b, c systems. In two-dimensional theories, relativistic bosons and fermions can be mapped into each other. Operators in the Fermi theory have equivalent expressions in terms of operators in the Bose theory.

To motivate this let us consider the CFT version of the position space operators: $\Upsilon_n = \text{Tr} U^n$ from (4.10). We write this in second quantized language and substitute (4.13). Cross terms between barred and unbarred fields involve operators that mix the two Fermi levels. Since we are only interested in the case of the decoupled Fermi level excitations we may replace:

$$\begin{aligned}
\Upsilon_n &= \text{Tr} U^n \rightarrow \oint dz z^{-1-n} c b(z) + \oint d\bar{z} \bar{z}^{-1+n} \bar{c} \bar{b}(\bar{z}) \\
&= \sum_m c_{n-m} b_m + \bar{c}_{m-n} \bar{b}_{-m} \\
&= \alpha_n + \bar{\alpha}_{-n}
\end{aligned} \tag{4.27}$$

where we have introduced a field $bc = i\partial_z\phi(z)$ which has expansion

$$\begin{aligned}
\partial_z\phi(z) &= i \sum_{m \in \mathbb{Z}} \alpha_m z^{m-1} \\
[\alpha_m, \alpha_n] &= [\bar{\alpha}_m, \bar{\alpha}_n] = m\delta_{m+n,0} \\
[\alpha_m, \bar{\alpha}_n] &= 0.
\end{aligned} \tag{4.28}$$

In terms of α_n , the Virasoro operators are:

$$L_n = \frac{1}{2} \sum \alpha_{n-m} \alpha_m \quad (4.29)$$

which satisfy (4.24), again with $c = 1$. Using the α we can define a vacuum $\alpha_n | 0 \rangle = 0$ for $n \geq 0$ and a statespace

$$\mathcal{H}_\alpha = \text{Span} \left\{ | \vec{k} \rangle \equiv \prod (\alpha_{-j})^{k_j} | 0 \rangle \right\}. \quad (4.30)$$

Bosonization states that there is a natural isomorphism:

$$\mathcal{H}_\alpha \cong \mathcal{H}_{bc}^{(0)} \quad (4.31)$$

We will not prove this but it can be made very plausible as follows. The Hilbert space may be graded by L_0 eigenvalue. The first few levels are:

$$\begin{aligned} L_0 = 1 & \quad \{ b_{-\frac{1}{2}} c_{-\frac{1}{2}} | 0 \rangle \} & \quad \{ \alpha_{-1} | 0 \rangle \} \\ L_0 = 2 & \quad \{ b_{-\frac{1}{2}} c_{-\frac{3}{2}} | 0 \rangle, b_{-\frac{3}{2}} c_{-\frac{1}{2}} | 0 \rangle \} & \quad \{ \alpha_{-2} | 0 \rangle, (\alpha_{-1})^2 | 0 \rangle \} \end{aligned} \quad (4.32)$$

At level $L_0 = n$, the fermion states are labeled by Young diagrams $Y \in \mathcal{Y}_n$ as in (4.20). At level $L_0 = n$, the Bose basis elements are labeled by partitions of n . We will label a partition of n by a vector $\vec{k} = (k_1, k_2, \dots)$ which has almost all entries zero, such that $\sum_j j k_j = n$. Bosonization states that the two bases are linearly related:

$$| Y \rangle = \sum_{\vec{k} \in \text{Partitions}(n)} \langle \vec{k} | Y \rangle | \vec{k} \rangle \quad (4.33)$$

We have seen that - in terms of the space of class functions - the Fermi basis corresponds to the rep basis. From (4.27) we see that states in the Bose basis correspond to the class functions:

$$\langle U | \vec{k} \rangle \equiv \Upsilon(\vec{k}) \equiv \prod_{j=1}^{\infty} (\text{Tr } U^j)^{k_j} \quad (4.34)$$

where Tr is the trace in the fundamental rep. In fact, a relation such as (4.33) holds for class functions at finite N and is a consequence of the Schur-Weyl duality theorem, as we explain next.

Remarks:

1. In the $U(N)$ theory we must consider states $| \vec{k}, \ell \rangle$ with wavefunctions

$$\langle U | \vec{k}, \ell \rangle \equiv \Upsilon(\vec{k}, \ell) \equiv (\det U)^\ell \prod_{j=1}^{\infty} (\text{Tr } U^j)^{k_j} \quad (4.35)$$

2. For other classical gauge groups the connection to free fermions has been studied in [168].

Exercise. Commutators

Check that $\Upsilon_n(U) \leftrightarrow \alpha_{-n} + \bar{\alpha}_n$ and $\Upsilon_n(U^\dagger) \leftrightarrow \alpha_n + \bar{\alpha}_{-n}$ form a commuting set of operators.

4.6. Schur-Weyl duality

We return to $N < \infty$.

All unitary irreducible reps of $SU(N)$ are obtained from reducing tensor products of the fundamental rep (for $U(N)$ we need tensor products of both the fundamental and its complex conjugate). Consider the action of $SU(N)$ on $V^{\otimes n}$ where V is the fundamental rep of $SU(N)$. Let $\rho(U)$ represent the action of U in $V^{\otimes n}$. The symmetric group S_n acts on $V^{\otimes n}$ by permuting the factors. Let $\tilde{\rho}$ be the map from S_n to $End(V^{\otimes n})$. It induces a map from the group ring $\mathbb{C}(S_n)$, also denoted by $\tilde{\rho}$.

Schur-Weyl duality: The commutant of $\rho(SU(N))$ in $V^{\otimes n}$ is $\tilde{\rho}(\mathbb{C}(S_n))$, and $V^{\otimes n}$ is completely reducible to the form: $V^{\otimes n} \cong \sum_{Y \in \mathcal{Y}_n} R(Y) \otimes r(Y)$

In the $SU(N)$ theory irreps can be labelled by Young diagrams with fewer than N rows: $Y \in \mathcal{Y}_n^{(N)}$, where $\mathcal{Y}_n^{(N)}$ is the set of valid Young diagrams for $SU(N)$. We denote by $R(Y)$ the corresponding irrep. We denote by $r(Y)$ the rep of S_n associated with Y . So if P_Y is the Young projector for the rep of S_n associated with Y , we have [235]

$$P_Y V^{\otimes n} \cong R(Y) \otimes r(Y) \quad (4.36)$$

Using Schur-Weyl duality we can relate $\Upsilon_{\vec{k}}$ to characters of irreducible reps:

$$\begin{aligned} \chi_{R(Y)}(U) &= \sum_{\sigma \in S_n} \frac{1}{n!} \chi_{r(Y)}(\sigma) \Upsilon_{\vec{k}(\sigma)}(U) \\ \Upsilon_{\vec{k}(\sigma)}(U) &= \sum_{Y \in \mathcal{Y}_n^{(N)}} \chi_{r(Y)}(C(\vec{k})) \chi_{R(Y)}(U). \end{aligned} \quad (4.37)$$

Here we identify conjugacy classes $C(\vec{k})$ of S_n with partitions \vec{k} of n , while $\vec{k}(\sigma)$ denotes the conjugacy class of an element σ . In the $U(N)$ case we have the same equations, diagonal in Q . To prove these relations we note that we can write the projector as

$$P_Y = \frac{d_{r(Y)}}{n!} \sum_{\sigma \in S_n} \chi_{r(Y)}(\sigma) \sigma, \quad (4.38)$$

where $d_{r(Y)} = \dim r(Y)$. Then we evaluate $\text{Tr}_{V^{\otimes n}}(UP_Y)$ in two ways, using (4.36) and (4.38). Noting that

$$\begin{aligned} \text{Tr}_{V^{\otimes n}}[U\sigma] &= \sum_{i_1 \dots i_n=1}^N U_{i_1 i_{\sigma(1)}} U_{i_2 i_{\sigma(2)}} \cdots U_{i_n i_{\sigma(n)}} \\ &= \Upsilon_{\vec{k}(\sigma)}(U), \end{aligned} \tag{4.39}$$

establishes the first equation. Evaluating $\text{Tr}_{V^{\otimes n}}[U\sigma]$ in two ways proves the second identity. Note that at finite N we do not need to add the Υ functions constructed from powers of U^\dagger since these may be expressed in terms of U .

Comparing (4.37) to the statement of bosonization in the $N \rightarrow \infty$ theory we see that the overlaps of Bose/fermi states are simply the characters of symmetric groups:

$$\langle \vec{k} | Y \rangle = \frac{1}{n!} \chi_{r(Y)}(C(\vec{k})) \tag{4.40}$$

Using (4.20) and the bosonisation formulae (4.27) we see that this gives a field theoretic formula for characters of the symmetric groups, as a vacuum expectation value of free fields. (This fact goes back to Sato, and is important in the theory of the KP hierarchy.)

4.7. The string interpretation

Gross and Taylor offered a very elegant string interpretation of the Hilbert space of class functions⁸. Consider spacetime to be a cylinder $S^1 \times \mathbb{R}$. The circle has an orientation. Put simply, the one-string Hilbert space is identified with the group algebra $\mathbb{C}[\pi_1(S^1)]$. The total string Hilbert space is then identified with the Fock space, $\text{Fock}[\mathbb{C}[\pi_1(S^1)]]$. Physically, strings of electric flux are winding around the circle.

For $j > 0$, α_{-j} creates a state of string winding j times around the spatial circle in the same sense as the orientation. Similarly, $\bar{\alpha}_{-j}$ creates a string with opposite orientation. This is the origin of the names ‘‘chiral’’ and ‘‘antichiral’’ above. Thus we may picture a chiral state corresponding to the partition \vec{k} as sets of k_i circles winding around a boundary of the target space i times as in fig. 13. A state corresponding to strings winding in both directions would be labelled by $|\vec{k}, \vec{\bar{k}}\rangle$. We refer to this basis as the string basis.

⁸ This interpretation is implicit in some previous works on strings in the $1/N$ expansion.

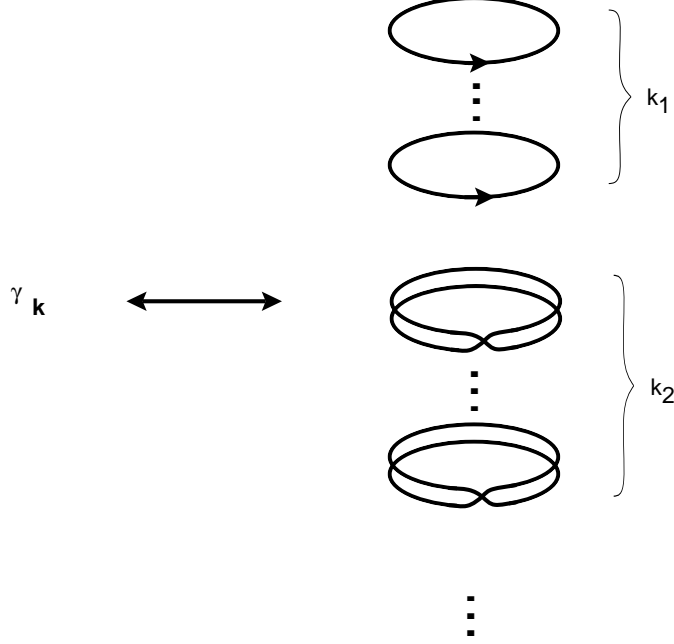

Fig. 13: Strings winding.

4.7.1. Back to class functions

It is interesting to translate the string states back into the language of class functions. We have seen that $|\vec{k}\rangle$ corresponds to the class function $\Upsilon_{\vec{k}}$. The story for the nonchiral theory is more complicated. The state $|\vec{k}_1, \vec{k}_2\rangle$ will correspond to a class function $\Upsilon_{\vec{k}_1, \vec{k}_2}$. We will also use the notation $\Upsilon_{v,w} = \Upsilon_{\vec{k}(v), \vec{k}(w)}$ for permutations v, w . These functions will have the form:

$$\Upsilon_{\vec{k}(v), \vec{k}(w)}(U, U^\dagger) = \Upsilon_{\vec{k}(v)}(U)\Upsilon_{\vec{k}(w)}(U^\dagger) + \dots \quad (4.41)$$

The class functions in the first term on the RHS of (4.41) are not orthonormal; the extra terms guarantee that the states satisfy the orthogonality relations [94],

$$\int dU \Upsilon_{v_1, w_1}(U)\Upsilon_{v_2, w_2}(U^\dagger) = \delta(\vec{k}_{v_1}, \vec{k}_{v_2})\delta(\vec{k}_{w_1}, \vec{k}_{w_2}) \prod_j j^{k_{v_1}^{(j)}} k_{v_1}^{(j)}! j^{k_{v_2}^{(j)}} k_{v_2}^{(j)}! \quad (4.42)$$

Explicitly, corresponding to permutations v and w we have

$$\Upsilon_{v,w} = \Upsilon_{\vec{k}(v), \vec{k}(w)} = \prod_j \sum_{m=1}^{\min(k_j, l_j)} [\text{Tr}(U^j)]^{k_j - m} [\text{Tr}(U^{\dagger j})]^{l_j - m} P_{k_j, l_j}(m). \quad (4.43)$$

Here j runs over positive integers; k_j and l_j are the numbers of cycles of length j in v and w respectively; and $P_{k_j, l_j}(m) = \binom{k_j}{m} \binom{l_j}{m} m! (-1)^m$. The functions (4.43) are called coupled loop functions [94].

The class functions $\Upsilon_{\vec{k}_1, \vec{k}_2}$ and $\chi_{R\bar{S}}$ are related by a generalization of the Frobenius relations (4.37). The character of the coupled rep is expected to be of the form

$$\chi_{R\bar{S}}(U) = \chi_R(U) \chi_S(U^\dagger) + \sum_{R', S'} C_{R', S'}^{R\bar{S}} \chi_{R'}(U) \chi_{S'}(U^\dagger), \quad (4.44)$$

where R' and S' are Young diagrams with fewer than n^+ , n^- boxes, respectively, and the C 's are some constants to be determined. For $n^+, n^- < N/2$, the rep $R\bar{S}$ uniquely determines R and S (this becomes clear from fig. 12). Together with irreducibility of the coupled reps, this leads to the orthogonality relation :

$$\int dU \chi_{R_1 \bar{S}_1}(U) \chi_{R_2 \bar{S}_2}(U^\dagger) = \delta_{R_1 R_2} \delta_{S_1 S_2}. \quad (4.45)$$

As a candidate for the generalisation to the non-chiral case of the relations between characters of chiral reps and symmetric group characters, which follow from Schur-Weyl duality (section 4.6), consider the following sum of coupled loop functions [94]:

$$\sum_{\sigma^+ \in S_{n^+}, \sigma^- \in S_{n^-}} \frac{\chi_r(\sigma^+)}{n^+!} \frac{\chi_s(\sigma^-)}{n^-!} \Upsilon_{\sigma^+, \sigma^-}(U). \quad (4.46)$$

It satisfies the two conditions (4.44) and (4.45). The first is clear by using (4.41). The second follows from orthogonality of the coupled loop functions and the orthogonality of characters of S_{n^+} and S_{n^-} . This establishes that

$$\chi_{R\bar{S}}(U) = \sum_{\sigma^+ \in S_{n^+}, \sigma^- \in S_{n^-}} \frac{\chi_r(\sigma^+)}{n^+!} \frac{\chi_s(\sigma^-)}{n^-!} \Upsilon_{\sigma^+, \sigma^-}(U). \quad (4.47)$$

4.8. String Interactions

The group theory Hamiltonian C_2 is *not* diagonal in the string basis of states. Thus, from the point of view of the string theory, there are nontrivial interactions in the theory. These interactions have nice interpretations in terms of the splitting and joining of strings [147,68].

Consider first the $U(N)$ theory. In terms of α 's, $H = \sum n_i^2 - E_0$ translates into

$$\begin{aligned}
 H &= e^2 N \left[(L_0 + \bar{L}_0) + H_{\text{interaction}} \right] \\
 H_{\text{interaction}} &= \frac{1}{N} \left\{ \sum_{n,m>0} \left(\alpha_{-n-m} \alpha_n \alpha_m + \bar{\alpha}_{-n-m} \bar{\alpha}_n \bar{\alpha}_m \right) \right. \\
 &\quad \left. + \sum_{n,m<0} \left(\alpha_n \alpha_m \alpha_{-n-m} + \bar{\alpha}_n \bar{\alpha}_m \bar{\alpha}_{-n-m} \right) \right\}.
 \end{aligned} \tag{4.48}$$

Thus, two strings winding with winding numbers n, m around the cylinder will propagate to a third string winding $n + m$ times. This is a 3 string interaction. For $SU(N)$ we have an additional interaction

$$\Delta H = \frac{e^2}{N} (L_0 - \bar{L}_0)^2 \quad .$$

4.8.1. The Fermi fluid picture

There is another nice way to think about the states in the large N limit, which has been employed by Douglas. In order to have a well-defined momentum operator in the large N limit we must scale

$$P = \frac{1}{N} \oint \Psi^\dagger \left(-i \frac{d}{d\theta} \right) \Psi$$

so \hbar in the problem is effectively $1/N$.

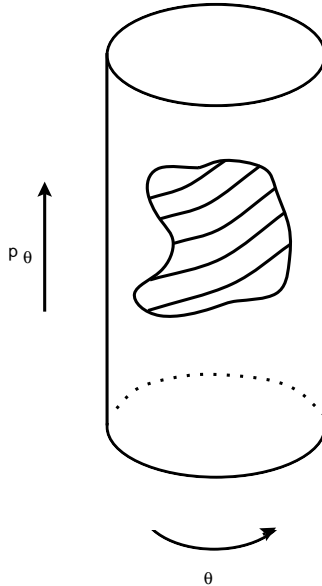

Fig. 14: Fermi liquid in phase space

We thus have N free fermions in a quantum system with $\hbar = 1/N$. The classical limit of such a system is best described in terms of phase space. Each fermion occupies an area $\Delta p \Delta \theta = \hbar$ in phase space, which is, in this case, $T^*S^1 = \{(\theta, p)\}$. N fermions occupy a region with a volume = 1. Classically, a state is described by density $\rho(\theta, p)$. Expectation values of operators correspond to integrals over phase space:

$$\langle \Psi | \mathcal{O} | \Psi \rangle = \int d\theta dp \mathcal{O}(\theta, p) \rho(\theta, p). \quad (4.49)$$

Moreover, ρ is a constant density times the characteristic function of a region of area = 1, so classically the state may be characterized as a region, as illustrated in fig. 14.

From the Fermi liquid point of view the energy may be nicely expressed in terms of the Fermi momenta p_{\pm} :

$$E = \int dp d\theta p^2 \rho(p, \theta) = \int d\theta \frac{1}{3} (p_+^3 - p_-^3). \quad (4.50)$$

The cubic Hamiltonian arises very naturally in the Fermi liquid point of view mentioned above. In particular the energy (4.50) becomes (4.48) under the substitution

$$\begin{aligned} p_+(z) &= (N/2 - iz\partial\phi) \\ p_-(z) &= (N/2 + iz\bar{\partial}\phi), \end{aligned} \quad (4.51)$$

where we used $\int d\theta \partial_{\tau}\phi = \int d\theta \partial_{\theta}\phi = 0$.

Remarks:

1. A similar Fermi liquid picture was developed by Polchinski for the $c = 1$ matrix model. The difference here is that the eigenvalues live on a circle as opposed to the real line, and there is no background potential. Note that the decoupling of the two sectors is very natural in terms of Fermi levels.
2. The Fermi system is completely integrable. There is an infinite number of conserved Hamiltonians corresponding to the center of the universal enveloping algebra. These are related to the infinite parameter family of natural Hamiltonians for YM_2 . For $N = \infty$ the algebra of conserved Hamiltonians is generated by all the Casimirs C_k . In terms of the relativistic fermions we have a $w_{\infty} \oplus w_{\infty}$ algebra. This has a nice interpretation in terms of area-preserving diffeomorphisms of the Fermi sea.

4.9. Casimirs and Symmetric Groups

Using Schur-Weyl duality we can express $SU(N)$ and $U(N)$ Casimirs in terms of quantities for the symmetric group: acting on $V^{\otimes n}$ any central element of the universal enveloping algebra must be expressed in terms of operators from the symmetric group. On the other hand, since it comes from $U(N)$, it must be in the center of $\mathbb{C}[S_n]$.

The relation between C_k and characters of symmetric group reps will be very important in deriving the $1/N$ expansion and finding a string interpretation. The most important for our purposes is

$$\begin{aligned} C_2(R(Y)) &= Nn + 2 \frac{\chi_r(Y)(T_{2,n})}{d_r(Y)} && U(N) \\ &= Nn + 2 \frac{\chi_r(Y)(T_{2,n})}{d_r(Y)} - n^2/N && SU(N) \end{aligned} \tag{4.52}$$

where $Y \in \mathcal{Y}_n^{(N)}$ and $T_{2,n} = \sum_{i < j} (ij) \in \mathbb{C}[S_n]$. The proof of this, and similar formulae for the higher Casimirs is rather technical, and may be found in the following appendix.

4.10. Appendix: Higher Casimirs

The relation between Casimirs and symmetric groups may be established by writing the value of the Casimir on a rep $R(Y)$ in terms of the row lengths n_i in the Young diagram Y . This gets nontrivial for the higher Casimirs (see for example [172]). Similarly the characters of symmetric groups can be evaluated in terms of the n_i , some explicit results are given in [112]. For C_2 this method was used in [94], to establish the relation with characters of symmetric groups. Here we will give a more direct construction of the transformation between Casimirs and symmetric group classes, which generalises easily to the higher Casimir case and which does not require explicitly knowing either the eigenvalues of the Casimirs or the characters of the symmetric groups, as functions of the n_i .⁹

We start by setting up some notation. A basis for the Lie algebra $u(N)$ of $U(N)$ is given by the matrices E_{ij} , $1 \leq i, j \leq N$ which have matrix elements $(E_{ij})_{\alpha\beta}$, $1 \leq \alpha \leq N, 1 \leq \beta \leq N$:

$$(E_{ij})_{\alpha\beta} = \delta_{i\alpha} \delta_{j\beta}. \tag{4.53}$$

They satisfy the relations

$$E_{ij} E_{kl} = \delta_{jk} E_{il} \tag{4.54}$$

⁹ Similar (independent) results were obtained in [88]. This appendix is based on [183].

$$[E_{ij}, E_{kl}] = \delta_{jk}E_{il} - \delta_{il}E_{jk}. \quad (4.55)$$

Let $\phi_i, 1 \leq i \leq N$, denote the standard basis for the fundamental rep V . The action of the generators of $u(N)$ is given by

$$E_{ij}\phi_k = \delta_{jk}\phi_i. \quad (4.56)$$

The following elements of the universal enveloping algebra (UEA) of $u(N)$

$$C_k^{U(N)} = \sum_{i_1 \cdots i_k} E_{i_1 i_2} E_{i_2 i_3} \cdots E_{i_k i_1}, \quad (4.57)$$

for $1 \leq k \leq N$, generate the centre of the algebra, which we denote by Ξ_N (see for example [235]). Other sets of generators can be obtained, for example, by changing the order of the E 's in (4.57). Any monomial in Ξ_N has a **natural grading** given by the sum of the degrees of all the generating elements in its expression in terms of generators.

Let $\phi_i^a, 1 \leq a \leq n$, denote the basis for the a 'th factor V in the tensor product $V^{\otimes n}$. The action of the generators of $u(N)$ on this tensor product is given by

$$E_{ij} \prod_{a=1}^n \phi_k^a = \sum_{a_1=1}^n E_{ij}^{a_1} \prod_{a=1}^n \phi_k^a. \quad (4.58)$$

where

$$E_{ij}^{a_1} \phi_k^{a_2} = \delta_{jk} \delta_{a_1 a_2} \phi_{ij}^{a_2}. \quad (4.59)$$

The operator representing the action of the k 'th Casimir can therefore be written as

$$\sum_{a_1, \dots, a_k \geq 1} \sum_{i_1 \cdots i_k = 1}^N E_{i_1 i_2}^{a_1} \cdots E_{i_k i_1}^{a_k}. \quad (4.60)$$

From the Schur-Weyl duality theorem, we expect that there is, in $V^{\otimes n}$, a transformation from operators representing the action of S_n to operators representing the centre as described by polynomials in the generators of Ξ_N . The explicit construction of the map uses the generalized exchange operators defined in [50,170].

Proposition 1

$\sum_{i_1 \cdots i_k} E_{i_1 i_2}^{a_1} E_{i_2 i_3}^{a_2} \cdots E_{i_k i_1}^{a_k} \equiv P^{a_1 a_2 \cdots a_k}$ acts in $V^{\otimes n}$ as the cyclic permutation $(a_1 a_2 \cdots a_k)$.

This is checked by using the explicit form of the action. For example, when $k = 2$ we have

$$\sum_{i_1 i_2} E_{i_1 i_2}^{a_1} E_{i_2 i_1}^{a_2} \phi_{j_1}^{a_1} \phi_{j_2}^{a_2} = \sum_{i_1 i_2} \delta_{i_2 j_1} \delta_{i_1 j_2} \phi_{i_1}^{a_1} \phi_{i_2}^{a_2} = \phi_{j_2}^{a_1} \phi_{j_1}^{a_2}. \quad (4.61)$$

This leads to

Proposition 2

On $V^{\otimes n}$ we have, for $k \geq 2$, the following equivalence of operators in the universal enveloping algebra (UEA) of $u(N)$ and the group ring of S_n :

$$P^{(k)} \equiv \sum_{a_1 \neq a_2 \neq \dots \neq a_k = 1}^n E_{i_1 i_2}^{a_1} E_{i_2 i_3}^{a_2} \dots E_{i_k i_1}^{a_k} = kT_k \quad (4.62)$$

where T_k is the element in the group ring of S_n which is the sum of all permutations in the conjugacy class characterised by one cycle of length k and remaining cycles of length 1. We will call the operators $P^{(k)}$ cycle operators.

The sum on the left counts cycles containing fixed numbers $a_1 a_2 \dots a_k$, once for each permutation of the numbers. Therefore it counts each cycle k times. This explains the factor k multiplying T_k . More generally we can write UEA operators for any conjugacy class in S_n .

Proposition 3

Let the index j run over the nontrivial cycles, i.e cycles of length $z_j \geq 2$ The permutation is represented by the operator :

$$\prod_j \left(\sum_{a_{j1} \neq \dots \neq a_{jz_j} = 1}^n P^{a_{j1} a_{j2} \dots a_{jz_j}} \right). \quad (4.63)$$

The sums are over a 's constrained to be all different from each other.

These operators can be written in a form where the sums over a 's are unrestricted, and in this form their relation to the Casimirs C_k will become apparent. We will give a more detailed discussion of the transformation of the cycle operators to Casimirs, and vice versa; the extension to operators corresponding to arbitrary permutations is straightforward. We will first discuss $P^{(k)}$ operators for $k \leq n$. Later we will describe how the transformation is carried out when we relax this restriction.

4.10.1. From cycle operators to Casimirs

We can rewrite the cycle operators:

$$\sum_{a_1 \neq \dots \neq a_k = 1}^n P^{a_1, a_2, \dots, a_k} = \sum_{a_1 \dots a_k = 1}^n P^{a_1, a_2, \dots, a_k} \prod_{i < j = 1}^k (1 - \delta_{a_i a_j}). \quad (4.64)$$

The leading term, obtained by picking 1 from all the factors in the product over i, j is the k' th Casimir. Terms obtained from the delta functions can be reduced to expressions in terms of lower order Casimirs, by using (4.54). We have then $P_k = C_k + \dots$ as an operator representing the action of Ξ_N in $V^{\otimes n}$. For fixed k , the equation holds for all n and N sufficiently large.

Now we can appeal to the statement of Schur-Weyl duality to show that the relation between permutations and Casimirs implies a relation between characters of permutations in $r(Y)$ and eigenvalues of Casimir operators in $R(Y)$. Using (4.62), we have

$$\sum_{a_1 \neq a_2 \dots \neq a_k} P^{a_1 \dots a_k} P_Y V^{\otimes n} = (1 \otimes kT_k) R(Y) \otimes r(Y) = (P^{(k)} \otimes 1) R(Y) \otimes r(Y), \quad (4.65)$$

where P_Y is the Young projector associated with the Young diagram Y . Tracing over the second factor we have

$$k\chi_{r(Y)}(T_k) = d_{r(Y)} P^{(k)}(R(Y)). \quad (4.66)$$

A similar equation can be written for any permutation using the operators defined in (4.63).

Now we discuss how to go from Casimirs to symmetric group characters:

$$\frac{C_k(R(Y))}{N^{k-1}} = \sum_{\sigma \in S_n} a_k(N, n, \sigma) \frac{\chi_{r(Y)}(\sigma)}{d_{r(Y)}}. \quad (4.67)$$

We will outline a construction which determines the coefficients $a_k(N, n, \sigma)$.

Starting from (4.60) we separate the unrestricted sum over a' s into a number of sums, separated according to the subsets of a' s which are equal to each other.

Examples:

We illustrate this procedure by rederiving the formula for C_2 .

$$\begin{aligned}
& \sum_{i_1, i_2=1}^N \sum_{a_1, a_2=1}^n E_{i_1 i_2}^{a_1} E_{i_2 i_1}^{a_2} \\
&= \sum_{i_1, i_2=1}^N \sum_{a_1 \neq a_2=1}^n E_{i_1 i_2}^{a_1} E_{i_2 i_1}^{a_2} + \sum_{i_1, i_2=1}^N \sum_{a_1=1}^n E_{i_1 i_2}^{a_1} E_{i_2 i_1}^{a_1} \\
&= 2 \frac{\chi_{r(Y)}(T_2)}{d_R} + NC_1 \\
&= 2 \frac{\chi_{r(Y)}(T_2)}{d_R} + Nn.
\end{aligned} \tag{4.68}$$

Applying this procedure for C_3 and C_4 , and collecting terms, we get

$$C_3(R(Y)) = 3 \frac{\chi_{r(Y)}(T_3)}{d_R} + 4N \frac{\chi_{R(Y)}(T_2)}{d_{r(Y)}} + N^2 n + n(n-1). \tag{4.69}$$

$$\begin{aligned}
C_4(R(Y)) &= 4 \frac{\chi_{r(Y)}(T_4)}{d_{r(Y)}} + 9N \frac{\chi_{r(Y)}(T_3)}{d_{r(Y)}} \\
&+ (6N^2 + (6n-10)) \frac{\chi_{r(Y)}(T_2)}{d_{r(Y)}} + 3N(n)(n-1) + N^3 n.
\end{aligned} \tag{4.70}$$

4.10.2. Casimirs for $SU(N)$

Casimirs for $SU(N)$ are closely related to those of $U(N)$ ([172,165]). This relation can be used to compute the expressions for Casimirs of $SU(N)$ in terms of characters of symmetric groups. Lie algebra elements in $su(N)$ can be written in terms of those of $u(N)$

$$\tilde{E}_{ij} = E_{ij} - \frac{\delta_{ij}}{N} \sum_{k=1}^N E_{kk}. \tag{4.71}$$

They satisfy the same commutation relations as in (4.55), have zero trace, and satisfy the condition that

$$\sum_i E_{ii} = 0. \tag{4.72}$$

Casimirs for $SU(N)$ are defined as follows:

$$C_k^{SU(N)} = \sum_{i_1 \cdots i_k=1}^N \tilde{E}_{i_1 i_2} \tilde{E}_{i_2 i_3} \cdots \tilde{E}_{i_k i_1}. \tag{4.73}$$

We will sometimes write C_k^{SU} , leaving the N label implicit. This leads to simple relations between the Casimirs of $SU(N)$ and those of $U(N)$:

$$C_k^{SU(N)} = \sum_{l=0}^k C_{k-l} \left(\frac{-C_1}{N}\right)^l \binom{k}{l}, \quad (4.74)$$

where $C_l = C_l^{(U(N))}$ for $l > 0$, and $C_0 = N$. These can be used to derive, for example, the formulae for C_2 and C_3

$$\begin{aligned} C_2^{SU}(R(Y)) &= C_2^{(U)}(R(Y)) - 2C_1 \left(\frac{C_1}{N}\right) + N \left(\frac{C_1}{N}\right)^2 \\ &= C_2^{(U)}(R(Y)) - \frac{n^2}{N} \\ C_3^{SU}(R(Y)) &= 3 \frac{\chi_{r(Y)}(T_3)}{d_{r(Y)}} + \left(4N - \frac{6n}{N}\right) \frac{\chi_{r(Y)}(T_2)}{d_{r(Y)}} + N^2 n - n - 2n^2 + \frac{2n^3}{N^2} \end{aligned} \quad (4.75)$$

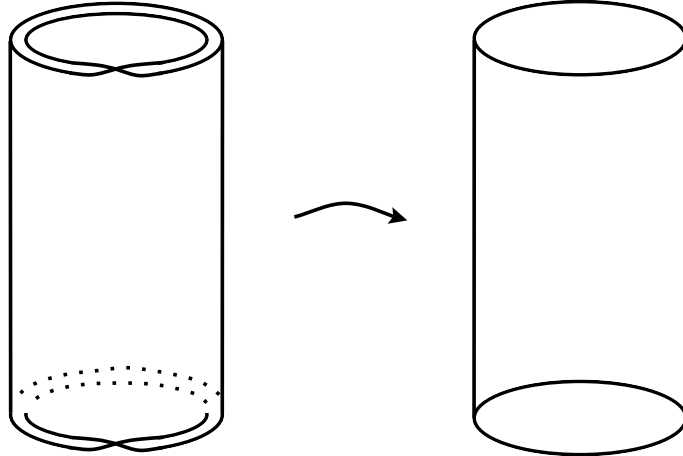

Fig. 15: A string winding twice around space propagates to a worldsheet which double covers the cylinder.

5. Covering Spaces

5.1. Motivation

When we interpret $\text{Tr}(U^j)$ as an operator creating a string at a fixed time, winding j times around the target space direction, we have introduced the concept of a covering

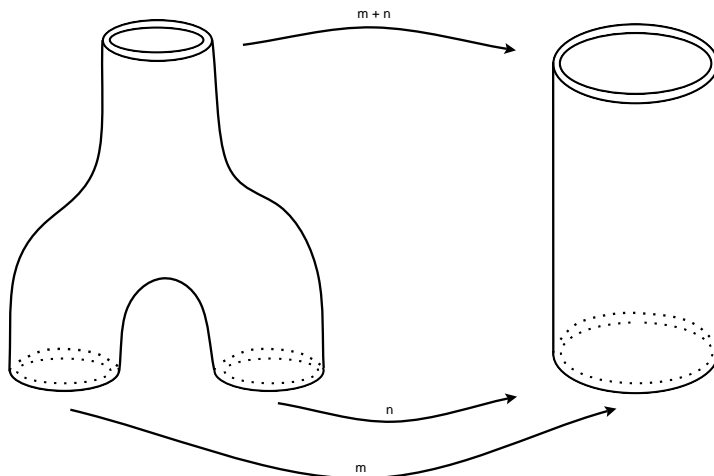

Fig. 16: String interactions described by the Hamiltonian of the previous chapter can be interpreted in terms of a covering by a pants diagram over the cylinder.

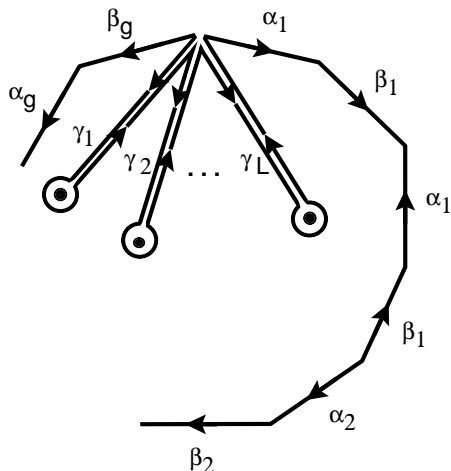

Fig. 17: A choice of generators for the homotopy group of a punctured surface. The curves $\gamma(P)$ become trivial if we fill in the puncture P .

manifold. Imagine propagating such a string. Naively we expect that propagation of such a string will define a covering map with the worldsheet covering the spacetime as in fig. 15.

Moreover, if we have two states at an initial time they will propagate to a third as governed by the interaction Hamiltonian (4.48) above. If we try to interpret this in terms of covering manifolds then we are led to an $(n + m)$ -fold branched covering of the cylinder by the pants diagram as follows: The lower two circles cover the ingoing circle on the cylinder by n and m -fold coverings $S^1 \rightarrow S^1$. The top circle on the pants covers the outgoing circle

on the cylinder $n + m$ times. See fig. 16.

5.2. Maps of $\Sigma_W \rightarrow \Sigma_T$

5.2.1. Homotopy groups

The homotopy groups of punctured Riemann surfaces may be presented in terms of generators and relations by

$$F_{p,L} \equiv \left\langle \{ \alpha_i, \beta_i \}_{i=1, \dots, p}, \{ \gamma_s \}_{s=1, \dots, L} \mid \prod_{i=1}^p [\alpha_i, \beta_i] \prod_{s=1}^L \gamma_s = 1 \right\rangle, \quad (5.1)$$

where $[\alpha, \beta] = \alpha\beta\alpha^{-1}\beta^{-1}$. Consider a compact orientable surface Σ_T of genus p . If we remove L distinct points, and choose a basepoint y_0 , then there is an isomorphism

$$F_{p,L} \cong \pi_1(\Sigma_T - \{P_1, \dots, P_L\}, y_0).. \quad (5.2)$$

This isomorphism is not canonical. The choices are parametrized by the infinite group $\text{Aut}(F_{p,L})$. On several occasions we will make use of a set of generators α_i, β_i and γ_i of π_1 so that, if we cut along curves in the homotopy class the surface looks like fig. 17.

5.2.2. Branched covers

Definition 5.1.

- a.) A continuous map $f : \Sigma_W \rightarrow \Sigma_T$ is a *branched cover* if any point $P \in \Sigma_T$ has a neighborhood $U \subset \Sigma_T$, such that the inverse image $f^{-1}(U)$ is a union of disjoint open sets on each of which f is topologically equivalent to the complex map $z \mapsto z^n$ for some n .
- b.) Two branched covers f_1 and f_2 are said to be *equivalent* if there exists a homeomorphism $\phi : \Sigma_W \rightarrow \Sigma_W$ such that $f_1 \circ \phi = f_2$.

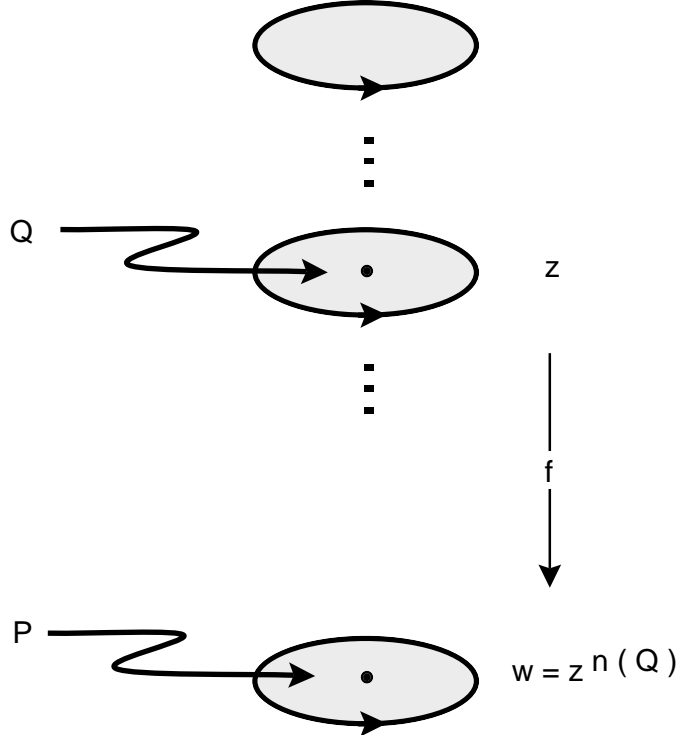

Fig. 18: Local model of a branched covering. On the disk containing Q the map is $z \rightarrow w = z^{n(Q)}$.

Locally, a branched covering looks like fig. 18. For $Q \in \Sigma_W$, the integer $n(Q)$, such that the map looks like $z \rightarrow w = z^{n(Q)}$, will be called the *ramification index* of Q and will be denoted $\text{Ram}(f, Q)$. For any $P \in \Sigma_T$ the sum

$$\deg(f) = \sum_{Q \in f^{-1}(P)} \text{Ram}(f, Q) \quad (5.3)$$

is independent of P and will be called the *index* of f (sometimes the degree). Points Q for which the integer n in condition (a) is bigger than 1 will be called *ramification points*. Points $P \in \Sigma_T$ which are images of ramification points will be called *branch points*.¹⁰ The set of branch points is the branch locus $S(f)$. The branching number at P is

$$B_P = \sum_{Q \in f^{-1}(P)} [\text{Ram}(f, Q) - 1]$$

The branching number of the map f is $B(f) = \sum_{P \in S(f)} B_P$. A branch point P for which the branching number is 1 will be called a *simple branch point*. Above a simple branch

¹⁰ Unfortunately, several authors use these terms in inequivalent ways.

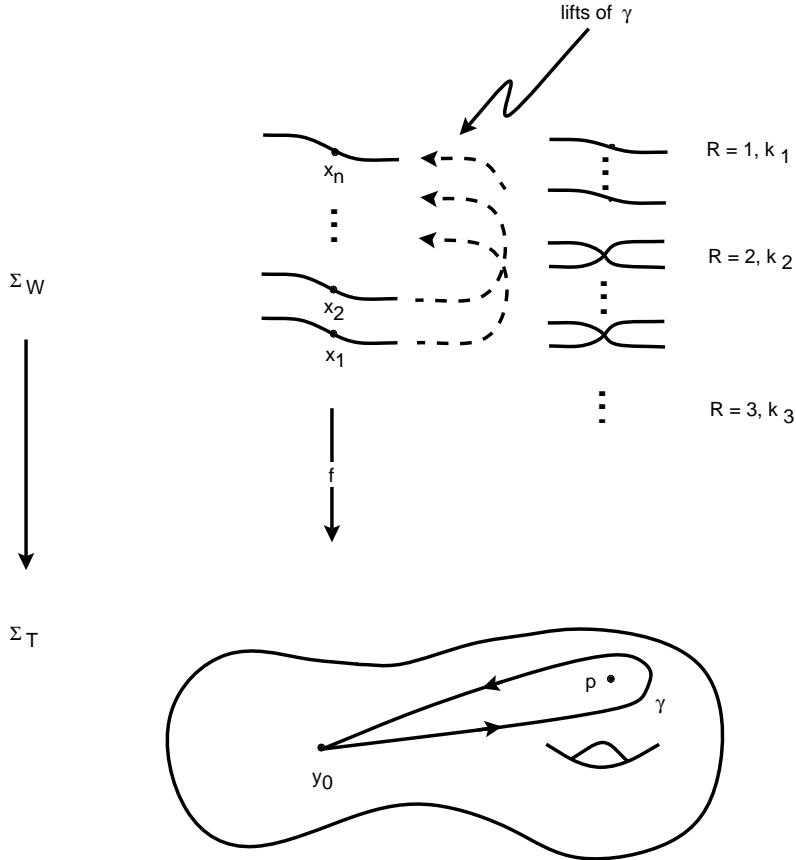

Fig. 19: Lifting of curves in a branched cover to produce elements of the symmetric group.

point all the inverse images have ramification index = 1, with the exception of one point Q with index = 2.

Globally, a branched cover looks like fig. 19. We will often use the Riemann-Hurwitz formula: If $f : \Sigma_W \rightarrow \Sigma_T$ is a branched cover of index n and branching number B , Σ_W has genus h , and Σ_T has genus p , then :

$$2h - 2 = n(2p - 2) + B. \tag{5.4}$$

Exercise. *Riemann-Hurwitz*

Prove the Riemann-Hurwitz formula by relating triangulations of Σ_W and Σ_T .

Equivalence classes of branched covers may be related to group homomorphisms through the following construction. Choose a point y_0 which is not a branch point and label

the inverse images $f^{-1}(y_0)$ by the ordered set $\{x_1, \dots, x_n\}$. Following the lift of elements of $\pi_1(\Sigma_T - S, y_0)$, the map f induces a homomorphism

$$f_{\#} : \pi_1(\Sigma_T - S, y_0) \rightarrow S_n \quad .$$

This construction may be illustrated as in fig. 19.

Exercise.

Suppose $\gamma(P)$ is a curve surrounding a branch point P as in fig. 17. There is a close relation between the cycle structure of $v_P = f_{\#}(\gamma(P))$ and the topology of the covering space over a neighbourhood of P .

- a.) If the cycle decomposition of v_P has r distinct cycles then show that $f^{-1}(P)$ has r distinct points.
- b.) Show that a cycle of length k corresponds to a ramification point Q of index k .

With an appropriate notion of equivalence the homomorphisms are in 1-1 correspondence with equivalence classes of branched covers.

Definition 5.2. Two homomorphisms $\psi_1, \psi_2 : \pi_1(\Sigma_T - S, y_0) \rightarrow S_n$ are said to be *equivalent* if they differ by an inner automorphism of S_n , i.e., if $\exists g$ such that $\forall x, \psi_1(x) = g\psi_2(x)g^{-1}$.

A crucial theorem for what follows is:

Theorem 5.1. [87,78]. Let $S \subset \Sigma_T$ be a finite set and n a positive integer. There is a one to one correspondence between equivalence classes of homomorphisms

$$\psi : \pi_1(\Sigma_T - S, y_0) \rightarrow S_n$$

and equivalence classes of n -fold branched coverings of Σ_T with branching locus S .

Proof: We outline the proof which is described in [78]. The first step shows that equivalent homomorphisms determine equivalent branched coverings. Given a branched cover, we can delete the branch points from Σ_T and the inverse images of the branch points from Σ_W giving surfaces $\bar{\Sigma}_W$ and $\bar{\Sigma}_T$ respectively. The branched cover restricts to a topological (unbranched) cover of $\bar{\Sigma}_T$ by $\bar{\Sigma}_W$. One shows that equivalent homomorphisms determine equivalent conjugacy classes of subgroups of $\pi_1(\bar{\Sigma}_T)$. Now apply a basic theorem in the theory of covering spaces [137] which establishes a one-one correspondence between conjugacy classes of subgroups of $\pi_1(X)$ and equivalence classes of topological coverings of the space X .

Similarly the second step proves that equivalent covers determine equivalent homomorphisms. The restriction of ϕ in definition 5.1.b to the inverse images of y_0 determines the permutation which conjugates one homomorphism into the other.

Finally, one proves that the map from equivalence classes of homomorphisms to equivalence classes of branched covers is onto. We cut n copies of Σ_T along chosen generators of $\pi_1(\Sigma_T - S)$ (illustrated in fig. 17), and we glue them together according to the data of the homomorphism. ♠

This theorem goes back to Riemann. Since the YM_2 partition function sums over covering surfaces which are not necessarily connected we do not restrict to homomorphisms whose images are transitive subgroups of S_n .

Definition 5.3. An *automorphism* of a branched covering f is a homeomorphism ϕ such that $f \circ \phi = f$.

Examples:

1. Consider $z \rightarrow w = z^n$, a cover of a disk by a disk. This has automorphism group \mathbb{Z}_n .
2. The hyperelliptic curve $y^2 = \prod_{i=1}^{2p+2} (x - e_i)$ is a double covering of the plane. For generic e_i it has automorphism group \mathbb{Z}_2 , $(y, x) \rightarrow (-y, x)$.

Exercise. *Automorphisms of covers*

Let $C(\psi)$ be the subgroup of S_n which fixes each element in the image of $\pi_1(\Sigma_T - S, y_0)$ in S_n under the homomorphism ψ .

- a.) Show that $\frac{n!}{|C(\psi)|}$, the number of cosets of this subgroup, is the number of distinct homomorphisms related to the given homomorphism by conjugation in S_n .
- b.) Show that $\text{Aut } f \cong C(\psi)$.

5.3. Hurwitz spaces

The Hurwitz space of branched coverings is described in[87,104]. Let $H(n, B, p; S)$ be the set of equivalence classes of branched coverings of Σ_T , with degree n , branching number B , and branch locus S , where S is a set of distinct points on a surface Σ_T of genus p . According to Theorem 5.1, $H(n, B, p; S)$ is a finite set. The union of these spaces over sets S with L elements is the Hurwitz space $H(n, B, p, L)$ of equivalence classes of branched coverings of Σ_T with degree n , branching number B and L branch points. Finally let $C_L(\Sigma_T)$ be the configuration space of ordered L -tuples of distinct points on Σ_T , that is

$$C_L(\Sigma_T) = \{(z_1, \dots, z_L) \in \Sigma_T^L \mid z_i \in \Sigma_T, z_i \neq z_j \text{ for } i \neq j\}.$$

The permutation group S_L acts naturally on C_L and we denote the quotient $\mathcal{C}_L(\Sigma_T) = C_L(\Sigma_T)/S_L$. There is a map

$$\pi : H(n, B, p, L) \rightarrow \mathcal{C}_L(\Sigma_T) \quad (5.5)$$

which assigns to each covering its branching locus. This map can be made a topological (unbranched) covering map [87] with discrete fiber $H(n, B, p; S)$ over $S \in \mathcal{C}_L$.

The lifting of closed curves in \mathcal{C}_L will in general permute different elements of the fibers $H(n, B, p, S)$. Note however that $\text{Aut } f$ is invariant along any lifted curve so that $\text{Aut } f$ is an invariant of the different components of $H(n, B, p, L)$.

5.4. Hurwitz Spaces and Holomorphic maps

One great advantage of branched covers is that they allow us to introduce the powerful methods of complex analysis, which are crucial to introducing ideas from topological field theory. Recall that a complex structure J on a manifold M is a tensor $J \in \text{End}(TM)$ such that $J^2 = -1$. The $\pm i$ eigenspaces define the holomorphic and antiholomorphic tangent directions.

In two dimensions a metric on a surface, $g_{\alpha\beta}dx^\alpha dx^\beta$, determines a complex structure: $\epsilon(g) \in \Gamma[\text{End}(T\Sigma_W)]$, $\epsilon^2 = -1$. Introduce the standard antisymmetric tensor $\hat{\epsilon}_{\alpha\gamma}$,

$$\hat{\epsilon}_{\alpha\gamma} = \begin{pmatrix} 0 & 1 \\ -1 & 0 \end{pmatrix} \quad (5.6)$$

and define $\epsilon_\alpha^\beta(g) = g^{1/2}\hat{\epsilon}_{\alpha\gamma}g^{\gamma\beta}$. Conversely, a complex structure determines a conformal class of metrics.

Indeed the moduli space of complex structures is just

$$\mathcal{M}_{h,0} = \text{MET}(\Sigma_W)/(\text{Diff}^+(\Sigma_W) \ltimes \text{Weyl}(\Sigma_W)) \quad (5.7)$$

We can characterize the complex coordinate system as the system in which $ds^2 = e^\phi |dz|^2$.

The connection of branched covers and holomorphic maps is provided by the following **Theorem**. Choose a complex structure J on Σ_T . Then given a branched cover $f : \Sigma_W \rightarrow \Sigma_T$ there is a unique complex structure on Σ_W making f holomorphic [1].

Proof: Use the complex structure $f^*(J)$ on Σ_W . Equivalently, just pull back a metric on Σ_T , inducing J , to get a metric g on Σ_W , inducing ϵ .

Conversely, any nonconstant holomorphic map $f : \Sigma_W \longrightarrow \Sigma_T$ defines a branched cover. It follows that we can consider the Hurwitz space $H(n, B, p, L)$ as a space of holomorphic maps. Let $H_c(n, B, p, L)$ is the space of holomorphic maps from connected world-sheets, with degree n , branching number B and L branch points. The complex structure, J , on Σ_T induces a complex structure on $H_c(n, B, p, L)$, such that π in (5.5) is a holomorphic fibration. Moreover, the induced complex structure on Σ_W defines a holomorphic map $m : H_c(n, B, p, L) \longrightarrow \mathcal{M}_{h,0}$ where $\mathcal{M}_{h,0}$ is the Riemann moduli space of curves of genus h , where h can be computed using (5.4). The image of H_c is a subvariety of $\mathcal{M}_{h,0}$.

5.5. Fiber Bundle approach to Hurwitz space

For comparison with topological field theory we will need another description of Hurwitz space as the base space of an infinite-dimensional fiber bundle.

Let Σ_W be a connected, orientable surface, and suppose Σ_T is a Riemann surface with a choice of Kähler metric and complex structure J . Let us begin with the configuration space

$$\widetilde{\mathcal{M}} = \{(f, g) \mid f \in \mathcal{C}^\infty(\Sigma_W, \Sigma_T), g \in \text{MET}(\Sigma_W)\} \quad (5.8)$$

where $\mathcal{C}^\infty(\Sigma_W, \Sigma_T)$ is the space of smooth (\mathcal{C}^∞) maps, $f: \Sigma_W \rightarrow \Sigma_T$ and $\text{MET}(\Sigma_W)$ is the space of smooth metrics on Σ_W .

The subspace of pairs defining a holomorphic map $\Sigma_W \rightarrow \Sigma_T$ is then given by

$$\widetilde{\mathcal{H}} = \{(f, g) : df\epsilon(g) = Jdf\} \subset \widetilde{\mathcal{M}}. \quad (5.9)$$

The defining equation $df\epsilon = Jdf$ is an equation in $\Gamma[\text{End}(T_x\Sigma_W, T_{f(x)}\Sigma_T)]$. Indeed in local complex coordinates, where ϵ, J are diagonal with diagonal eigenvalues $\pm i$ we can write:

$$df + Jdf\epsilon = 2 \begin{pmatrix} 0 & \bar{\partial}f \\ \partial\bar{f} & 0 \end{pmatrix} \quad (5.10)$$

Let $\text{Diff}^+(\Sigma_W) \ltimes \text{Weyl}(\Sigma_W)$ be the semidirect product of the group of orientation preserving diffeomorphisms of Σ_W and the group of Weyl transformations on Σ_W . There is a natural action of this group on $\widetilde{\mathcal{M}}$. Two pairs (f, g) define equivalent holomorphic maps iff they are related by this group action. Therefore, the quotient space

$$\mathcal{H}(\Sigma_W, \Sigma_T) \equiv \widetilde{\mathcal{M}} / (\text{Diff}^+(\Sigma_W) \ltimes \text{Weyl}(\Sigma_W)) \quad (5.11)$$

parametrizes holomorphic maps $\Sigma_W \longrightarrow \Sigma_T$.

5.6. Riemann and Hurwitz Moduli Spaces

Riemann and Hurwitz moduli spaces have orbifold singularities associated with automorphisms of the surface or automorphisms of the cover. It will be quite important in chapter 7 that, while $H(n, B, p, L)$ has no singularities, the space $\mathcal{H}(\Sigma_W, \Sigma_T)$ does have orbifold singularities. Roughly speaking $\mathcal{H}(\Sigma_W, \Sigma_T)$ is “made” out of the spaces $\Pi_{n(2-2h)-B=2-2p}H(n, B, p, L)$.

These moduli spaces are also noncompact. When discussing the intersection theory of these moduli spaces it is quite necessary to compactify them. The process of compactification is very complicated and tricky. In chapter 6 below we describe some of the intuitive pictures, associated with collisions of branchpoints, that are used in constructing compactifications. A compactification of Hurwitz spaces has been given in [104].

6. $1/N$ Expansions of YM_2 amplitudes

In this chapter we derive the asymptotic $1/N$ expansion of the exact results of YM_2 .

6.1. Some preliminary identities from group theory

6.1.1. Finite group identities

We will need several identities of finite group theory, applied to S_n . First we have the standard orthogonality relations:

$$\begin{aligned} \frac{1}{n!} \sum_{\rho} \chi_{r_1}(\rho) \chi_{r_2}(\rho^{-1}) &= \delta_{r_1, r_2} \\ \sum_{r \in \text{Rep}(S_n)} \chi_r(\rho) \chi_r(\sigma) &= \delta_{T_\sigma, T_\rho} \frac{n!}{|T_\sigma|} \\ \Rightarrow \frac{1}{n!} \sum_r d_r \chi_r(\rho) &= \delta(\rho) \end{aligned} \tag{6.1}$$

where $|T_\sigma|$ is the order of the conjugacy class containing the permutation σ .

We will frequently use the fact that:

$$\sum_{\sigma \in T} \frac{\chi_r(\sigma)}{d_r} \frac{\chi_r(\rho)}{d_r} = \sum_{\sigma \in T} \frac{\chi_r(\sigma\rho)}{d_r} \tag{6.2}$$

where T is any conjugacy class, and d_r is the dimension of the representation r of the symmetric group.

Finally, a simple but important consequence of these identities is that [94]:

$$\left(\frac{n!}{d_r}\right)^2 = \sum_{s,t \in S_n} \frac{\chi_r(sts^{-1}t^{-1})}{d_r} \quad (6.3)$$

To prove the last equation, (6.2) is used to separate the sum of characters into a sum of products of two characters to get

$$n! \sum_{t \in S_n} \frac{\chi_r(t)}{d_r} \frac{\chi_r(t^{-1})}{d_r} \quad . \quad (6.4)$$

The orthogonality expressed in (6.1) is then used to do the sums.

6.1.2. Powers of dimensions

As a final important formula we will derive a key expression for the powers of dimensions of $SU(N)$ representations in terms of characters of the symmetric group. We begin with

$$\begin{aligned} \dim R(Y) &= \frac{N^n}{n!} \chi_{r(Y)}(\Omega_n) \\ \Omega_n &= \sum_{v \in S_n} \left(\frac{1}{N}\right)^{n-K_v} v \\ &= 1 + \frac{1}{N} T_2 + \frac{1}{N^2} T_3 + \dots \end{aligned} \quad (6.5)$$

obtained by setting $U = 1$ in eq. (4.37). K_v is the number of cycles in the cycle decomposition of v . This generalizes to:

$$(\dim R(Y))^m = \left(\frac{N^n d_{r(Y)}}{n!}\right)^m \frac{\chi_{r(Y)}(\Omega_n^m)}{d_{r(Y)}} \quad (6.6)$$

where m is any integer, positive or negative. To write expressions for inverse powers of the dimension in terms of the symmetric group it is convenient to define the inverse of Ω_n in the group algebra. For $N > n$, this inverse always exists, but for $N < n$ it may not. In the large N expansion we may always invert it.

6.2. Chiral Gross-Taylor Series

We are now ready to derive the $1/N$ expansion of

$$Z = \sum_R (\dim R)^{2-2p} e^{-\frac{A}{2N} C_2(R)} \quad (6.7)$$

where we have put in the correct scaling of the coupling constant $e^2 AN \rightarrow A$, which is held fixed for $N \rightarrow \infty$.

The central idea of the calculation is to use Schur-Weyl duality to translate $SU(N)$ representation theory into S_n representation theory, and interpret the latter, geometrically, as data defining a branched cover.

To implement this idea we make the replacement:

$$\sum_{R \in \text{Rep}(SU(N))} f(R) = \sum_{n \geq 0} \sum_{Y \in \mathcal{Y}_n^{(N)}} f(R(Y)) \quad (6.8)$$

We first explain the derivation for the ‘‘chiral expansion.’’ This keeps only the states in $\mathcal{H}_{\text{chiral}}$ in the large N Hilbert space, and is defined by dropping the constraint on the number of rows so:

$$\sum_{R \in \text{Rep}(SU(N))} f(R) \rightarrow \sum_{n \geq 0} \sum_{Y \in \mathcal{Y}_n} f(R(Y)) \quad (6.9)$$

Physically this turns out to be the restriction to orientation-preserving strings.

Now we translate the various expressions in (6.7) into quantities involving the symmetric group. First we have:

$$\begin{aligned} & (\dim R(Y))^{2-2p} \\ &= N^{n(2-2p)} \left(\frac{d_r(Y)}{n!}\right)^2 \left[\left(\frac{n!}{d_r(Y)}\right)^2\right]^p \frac{\chi_r(Y)(\Omega_n^{2-2p})}{d_r(Y)} \\ &= N^{n(2-2p)} \left(\frac{d_r(Y)}{n!}\right)^2 \sum_{s_i, t_i \in S_n} \prod_i \frac{\chi_r(Y)(s_i t_i s_i^{-1} t_i^{-1})}{d_r(Y)} \frac{\chi_r(Y)(\Omega_n^{2-2p})}{d_r(Y)} \\ &= N^{n(2-2p)} \left(\frac{d_r(Y)}{n!}\right)^2 \sum_{s_i, t_i \in S_n} \frac{\chi_r(Y)(\prod_i s_i t_i s_i^{-1} t_i^{-1})}{d_r(Y)} \frac{\chi_r(Y)(\Omega_n^{2-2p})}{d_r(Y)} \\ &= N^{n(2-2p)} \left(\frac{d_r(Y)}{n!}\right)^2 \sum_{s_i, t_i \in S_n} \frac{\chi_r(Y)(\Omega_n^{2-2p} \prod_i s_i t_i s_i^{-1} t_i^{-1})}{d_r(Y)} \end{aligned} \quad (6.10)$$

Similarly, we can expand the exponential of the area using the formula:

$$C_2(R(Y)) = nN + 2 \frac{\chi_r(Y)(T_2)}{d_r(Y)} - \frac{n^2}{N} \quad (6.11)$$

Using (6.2) repeatedly we get:

$$\begin{aligned}
& (\dim R(Y))^{2-2p} e^{-\frac{A}{2N} C_2(R(Y))} \\
&= e^{-\frac{1}{2}A(n-\frac{n^2}{N^2})} N^{n(2-2p)} \left(\frac{d_r(Y)}{n!}\right)^2 \\
& \sum_{s_i, t_i \in S_n} \frac{\chi_r(Y) \left(\prod_i s_i t_i s_i^{-1} t_i^{-1} \Omega_n^{2-2p}\right)}{d_r(Y)} e^{-\frac{A}{N} \chi_r(Y)(T_2)} \\
&= \sum_{l \geq 0} \frac{(-A)^l}{l!} e^{-\frac{1}{2}A(n-\frac{n^2}{N^2})} N^{n(2-2p)-l} \left(\frac{d_r(Y)}{n!}\right)^2 \\
& \sum_{s_i, t_i \in S_n} \frac{\chi_r(Y) (\Omega_n^{2-2p} \prod_i s_i t_i s_i^{-1} t_i^{-1})}{d_r(Y)} \frac{\chi_r(Y)(T_{2,n}^l)}{d_r(Y)} \\
&= \sum_{l \geq 0} \frac{(-A)^l}{l!} e^{-\frac{1}{2}A(n-\frac{n^2}{N^2})} N^{n(2-2p)-l} \left(\frac{d_r(Y)}{n!}\right)^2 \\
& \sum_{s_i, t_i \in S_n} \frac{\chi_r(Y) (\Omega_n^{2-2p} T_{2,n}^l \prod_i s_i t_i s_i^{-1} t_i^{-1})}{d_r(Y)}
\end{aligned} \tag{6.12}$$

Now, in the chiral sum we have an unrestricted sum over $Y \in \mathcal{Y}_n$ so we use (6.1) to obtain:

$$\begin{aligned}
& Z^+(A, p, N) \\
&= 1 + \sum_{n \geq 1, \ell \geq 0} N^{n(2-2p)-\ell} e^{-\frac{1}{2}A(n-\frac{n^2}{N^2})} \frac{(-A)^\ell}{\ell!} \sum_{s_i, t_i \in S_n} \frac{1}{n!} \delta(\Omega_n^{2-2p} T_{2,n}^\ell \prod_1^p [s_i, t_i])
\end{aligned} \tag{6.13}$$

Acting on an element of the group algebra, the delta function evaluates the element (regarded as a function on the group) at the identity permutation. We now write $n^2 = n(n-1) + n$ and expand the remaining factor in the exponential to get the ‘‘chiral Gross-Taylor series’’ (CGTS) as

$$\begin{aligned}
& Z^+(A, p, N) \\
&= 1 + \sum_{n=1, i, t, h=0}^{\infty} e^{-nA/2} (-1)^i \frac{(A)^{i+t+h}}{i!t!h!} \\
& \left(\frac{1}{N}\right)^{n(2p-2)+2h+i+2t} \left(\frac{n}{2}\right)^h \left(\frac{n(n-1)}{2}\right)^t \\
& \sum_{p_1, \dots, p_i \in T_{2,n}} \sum_{s_1, t_1, \dots, s_p, t_p \in S_n} \left[\frac{1}{n!} \delta(p_1 \cdots p_i \Omega_n^{2-2p} \prod_{j=1}^p s_j t_j s_j^{-1} t_j^{-1}) \right].
\end{aligned}$$

(6.14)

6.3. Nonchiral Sum

The expansion (6.13), based on (6.9), does not give the correct large N asymptotics of (6.7). In (6.13) the contribution to Z from large representations with a number of boxes of order N is separated into infinitely many terms, each of which is exponentially damped $O(e^{-N})$. There are representations R with order N boxes for which $\frac{C_2(R)}{N}$ is $O(N^0)$. These reps contribute terms to (3.20) which are not exponentially damped as N goes to infinity. Therefore a finite number of terms in the expansion (6.13) will not give an answer differing from (3.20) by exponentially small amounts. For example, the representation R , with $(N-1)$ rows of length 1, is conjugate to the fundamental rep and so has the same Casimir, $C_2 = N - 1/N$. In the chiral expansion, however, its contribution $(\dim R)^{2-2p} e^{-\frac{AC_2(R)}{2N}}$ is written $(\dim R)^{2-2p} e^{-\frac{A}{2}((N-1)+(1-\frac{1}{N^2}-N+1))}$, the first term is kept in the exponent and the second is expanded out, giving infinitely many terms, each exponentially damped.

Getting the correct asymptotic expansion requires isolating all the representations which have $\frac{C_2(R)}{N} \sim O(N^0)$, and making sure their contributions appear after a finite number of terms. Gross and Taylor argued that the most general reps which satisfy $\frac{C_2(R)}{N} \sim O(N^0)$ are the ‘coupled reps’ defined in chapter 4. The coupled expansion is defined so as to pick up all the perturbative contributions of the coupled reps. It is obtained by the replacement

$$\sum_{\text{Reps}} f(\text{Rep}) \longrightarrow \sum_{n^+, n^-} \sum_{R \in Y_{n^+}, S \in Y_{n^-}} f(R\bar{S}). \quad (6.15)$$

The procedure of constructing the coupled expansion may appear strange. Indeed at finite N , it would overcount reps, which leads in [19] to a chiral approach to the problem of string interpretation at finite N . Completing the proof that the coupled expansion is the asymptotic expansion to (6.7) requires analyzing the behaviour of $\frac{C_2(R)}{N}$, $\dim R$ and the multiplicity of Young diagrams which do not appear after a finite number of terms in the coupled expansion, and showing that their contributions are non-perturbative.

In order to find a formula for $\dim R\bar{S}$, we can use (4.47):

$$\chi_{R\bar{S}}(U) = \sum_{v \in S_{n^+}, w \in S_{n^-}} \frac{\chi_r(v)}{n^+!} \frac{\chi_s(w)}{n^-!} \Upsilon_{v,w}(U, U^\dagger) \quad (6.16)$$

where R corresponds to a Young diagram which has n^+ boxes and S corresponds to one with n^- boxes, where r and s are the reps of S_{n^+} and S_{n^-} corresponding to the same Young diagram. The $\Upsilon_{v,w}$ are the coupled loop functions of chapter 4.

By setting U to 1 in (4.47), (4.43) we get the expansion in N for $\dim R\bar{S}$.

$$\dim R\bar{S} = \frac{N^{n^++n^-}}{n^+!n^-!} \chi_{R\bar{S}}(\Omega_{n^+,n^-}), \quad (6.17)$$

where Ω_{n^+,n^-} are certain elements of the group algebra of the symmetric group $S_{n^+} \times S_{n^-}$ with coefficients in $\mathbb{R}((1/N))$. Explicitly, Ω_{n^+,n^-} is an element of the group algebra of $S_{n^+} \times S_{n^-}$ given by

$$\Omega_{n^+,n^-} = \sum_{v \in S_{n^+}, w \in S_{n^-}} (v \otimes w) P_{v,w} \left(\frac{1}{N^2} \right) \left(\frac{1}{N} \right)^{(n^+-K_v)+(n^--K_w)} \quad (6.18)$$

The polynomial $P_{v,w} \left(\frac{1}{N^2} \right)$ can be read off from (4.43):

$$P_{v,w} \left(\frac{1}{N^2} \right) = \prod_j \sum_m^{\min(k_j, l_j)} P_{k_j, l_j}(m) \frac{1}{N^{2m}}. \quad (6.19)$$

Manipulations similar to those of the chiral theory (section 6.2), now performed for the product group $S_{n^+} \times S_{n^-}$ instead of S_n , lead to an expression analogous to (6.14)

$$\begin{aligned}
& Z(A, p, N) \\
& \sim 1 + \sum_{n^\pm=1, i^\pm=0}^{\infty} \sum_{p_1^\pm, \dots, p_{i^\pm}^\pm \in T_2 \subset S_{n^\pm}} \sum_{s_1^\pm, t_1^\pm, \dots, s_p^\pm, t_p^\pm \in S_{n^\pm}} \\
& \left(\frac{1}{N} \right)^{(n^++n^-)(2p-2)+(i^++i^-)} \frac{(-1)^{(i^++i^-)}}{i^+!i^-!n^+!n^-!} (A)^{(i^++i^-)} \\
& e^{-\frac{1}{2}(n^++n^-)A} e^{\frac{1}{2}((n^+)^2+(n^-)^2-2n^+n^-)A/N^2} \\
& \delta_{S_{n^+} \times S_{n^-}} \left(p_1^+ \cdots p_{i^+}^+ p_1^- \cdots p_{i^-}^- \Omega_{n^+,n^-}^{2-2p} \prod_{j=1}^p [s_j^+, t_j^+] \prod_{k=1}^p [s_k^-, t_k^-] \right),
\end{aligned}$$

(6.20)

where $[\alpha, \beta] = \alpha\beta\alpha^{-1}\beta^{-1}$. Here δ is the delta function on the group algebra of the product of symmetric groups $S_{n^+} \times S_{n^-}$.

6.4. Area Functions

We now want to interpret (6.20) and its chiral analogue geometrically in terms of coverings. For the moment let us put $\Omega \rightarrow 1$. We will return to the Ω -factor in the next chapter.

The first salient point is that we have an expansion in $1/N^2$ and the contribution of connected surfaces to the partition function can be written in the form

$$Z^+(A, p, N) = \sum_h (1/N)^{2p-2} Z_{h,p}^+(A) = \sum_h (1/N)^{2p-2} \sum_n e^{-nA/2} Z_{n,h,p}^+(A) \quad (6.21)$$

$Z_{h,p}^+(A)$ is the contribution from surfaces (possibly disconnected) with Euler characteristic $2 - 2p$. $Z_{n,h,p}^+(A)$ is polynomial in A , of degree at most $(2p - 2) - n(2p - 2) = B$.

Case 1: For $p > 1$, $Z_{(h,p)}^+(A)$ is a finite sum of terms. It has a finite, nonvanishing $A \rightarrow 0$ limit.

Case 2: For $p = 1$, $Z_{(1,1)}^+(A)$ is an infinite sum calculated in [94] to be $e^{-A/12}\eta(A)$. The sum converges for $A > 0$. $Z_{(2,1)}(A)$ was calculated in [68]. The free energies for the chiral $U(N)$ theory have been calculated for $p = 1$, and h up to eight, and its modular properties investigated [186].

Case 3: For $p = 0$: $Z_{0,0}^+(A)$ has finite radius of convergence and has been investigated in [204]. The range of validity of the coupled Gross Taylor expansion for $SU(N)$ is limited to large area in the case of a spherical target. Douglas and Kazakov [72] showed that the leading order (in $1/N$) term in the free energy shows a third order phase transition as a function of the area. Below the critical area $g^2 A = \pi^2$ the large area expansion is not valid. A string interpretation of the phase transition has been given in [204,56]. The detection of any stringy features in the weak coupling result would be very interesting.

6.5. Geometrical Interpretation of the A -dependence

In (6.14) we have a sum over 4 positive integers, n, i, t, h . In this section we will associate geometrical pictures with the A dependence coming from these sums. These pictures are meant to be heuristic. The interpretation can be ambiguous, and sometimes the pictures can be misleading. For example, $i, t, h > 0$ are the most subtle dependences from the topological string point of view.

6.5.1. $i > 0$: Movable branch points

Picking the leading term, 1, from the Ω_n we have a sum over i, t, h and the permutations $p_1, \dots, p_i, s_1, t_1, \dots, s_p, t_p$. First consider the terms with $h = t = 0$. We are left with a sum of homomorphisms from $\pi_1(\Sigma_T - \{i \text{ punctures}\})$ into S_n , where the generators around the i punctures map to the class of simple transpositions. Using theorem 5.1, we see that the sum is counting branched covers with i points being simple branch points, with weight equal to the inverse of the order of the automorphism group of the cover. Note that the power of N is the Euler character of the worldsheet as given by the Riemann Hurwitz formula (5.4).

6.5.2. $t > 0$: Tubes

For terms with $h, t > 0$ the power of N is smaller than that given by (5.4), by $2t + 2h$. This is understood in terms of extra handles and tubes on the worldsheet which map to points [145]. The n dependence in $(\frac{n(n-1)}{2N^2})^t$ is understood in terms of maps from a worldsheet which has t tubes connecting two sheets each. The factor $\frac{n(n-1)}{2}$ is the number of ways of choosing which pair of sheets is being connected by the tube. The $\frac{1}{t!}$ is understood as a symmetry factor due to the tubes being indistinguishable.

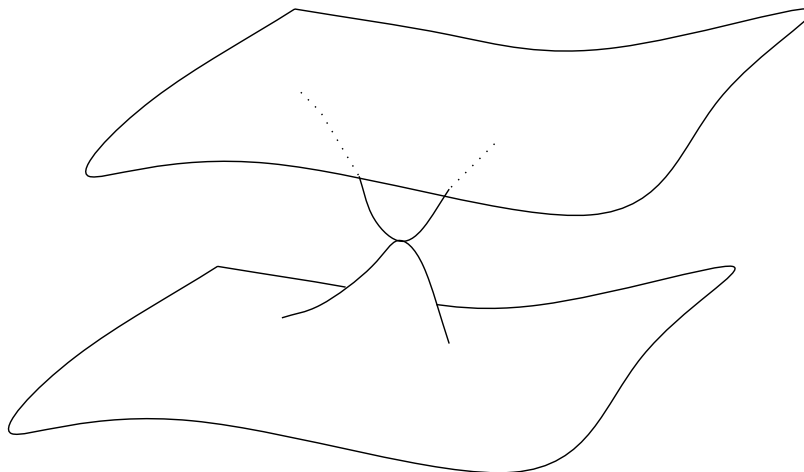

Fig. 20: Pinched tube.

The n dependence can, equivalently, be understood as the weight for the collision of two simple branch points to produce a tube.

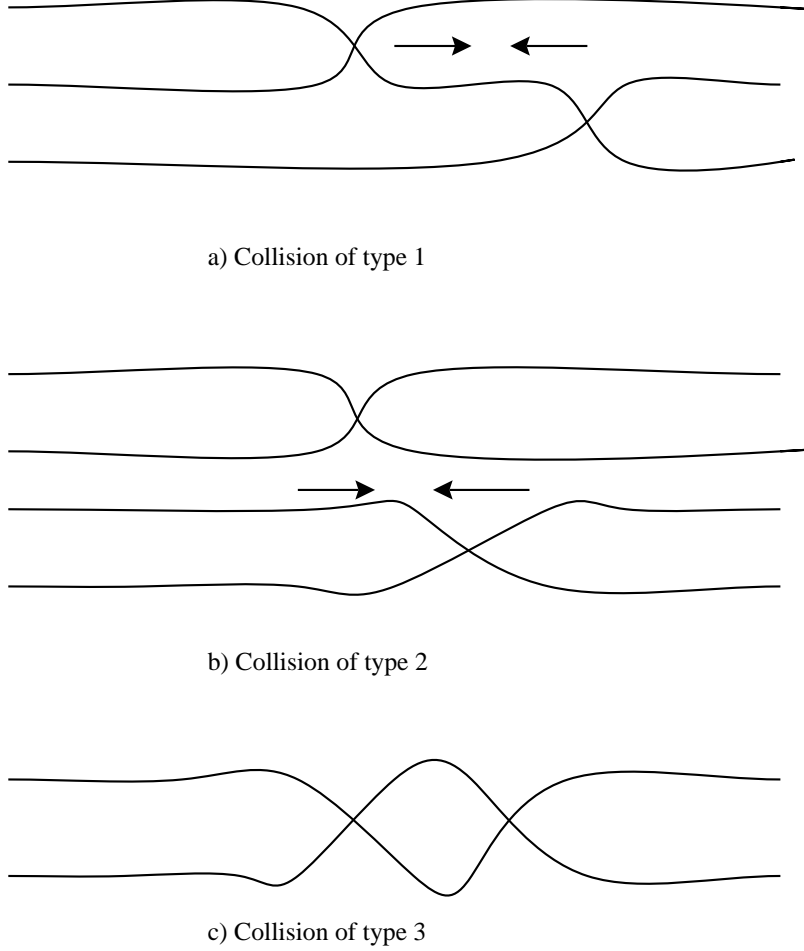

Fig. 21: Three types of collisions of simple ramification points

When two simple branch points approach each other, they can produce either a ramification point of index 3, or two ramification points of index 2, or a tube with no ramification (see fig. 21) . This fact can be read off from the following multiplication in the class algebra of symmetric groups:

$$\sum_{q_1, q_2 \in T_2} q_1 q_2 = 3 \sum_{q \in T_3} q + \sum_{q \in T_{2,2}} q + n(n-1)/2. \quad (6.22)$$

The coefficient of the identity, corresponding to the collisions producing no ramification and a tube, is exactly the number associated with each of the t tubes.

6.5.3. $h > 0$: *Bubbled handles*

In [145] the factor $\frac{(An)^h}{h!N^{2h}}$ is interpreted in terms of h “infinitesimally small” handles which map to points on the target. The factor A is due to an integration over the image of

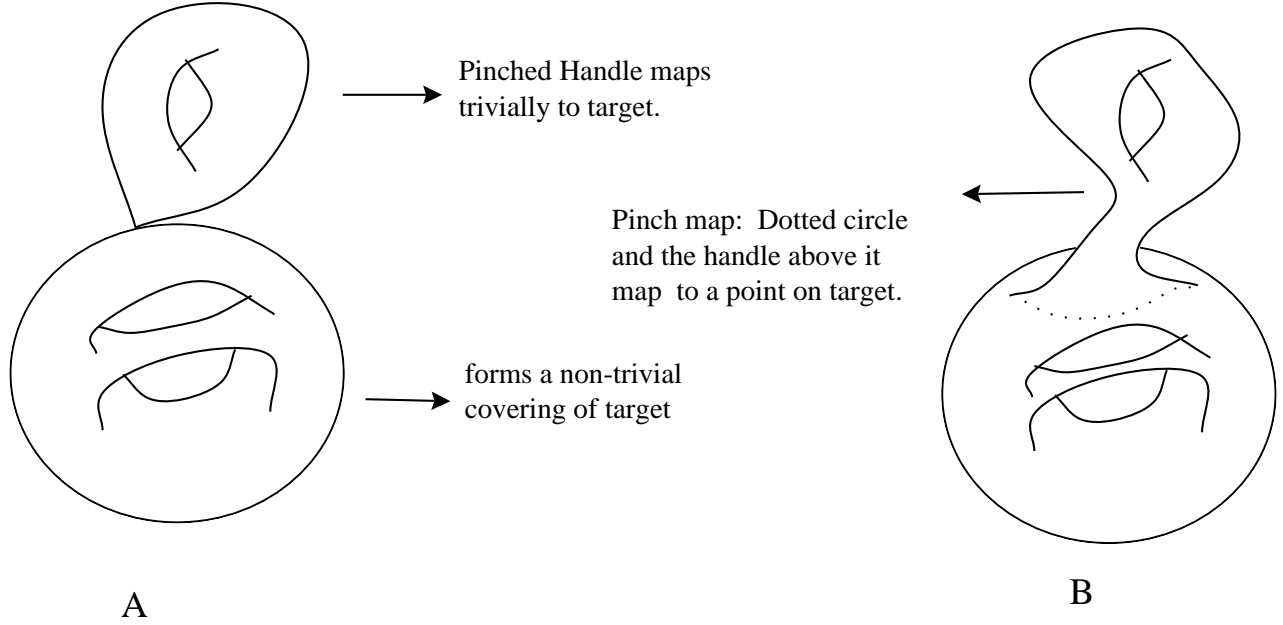

Fig. 22: ‘A’ is a holomorphic map at the boundary of the space of maps ; ‘B’ (a pinch map) is not.

the collapsed handle on the target space. There is no modulus for the area of the handle being pinched off which is why they can be thought to be infinitesimally small. Each handle decreases the Euler character by two so the power of N is appropriate.

The precise nature of the maps contributing the factors $\frac{(An)^h}{h!N^{2h}}$ is slightly ambiguous. Two different interpretations of these factors are illustrated in fig. 22. If the factors were due to maps of type A then they would represent the phenomenon of bubbling recently discussed in the context of topological string theories [31]. In [31] degenerate instantons are shown to be required in the computation of partition functions of topological field theories. For these degenerate instantons the worldsheet has handles, bubbled off from the part of the worldsheet mapping nontrivially to the target, which are mapped to points on the target. From this point of view there is no dependence on the area of the bubbled off handles because the pull-back of the Kähler form to these bubbled handles is trivial (as the map restricted to these handles is constant). According to the interpretation of YM_2 in chapter 18, collapsed handles relevant for chiral YM_2 are of type A in fig. 22.

6.6. Generalizations

6.6.1. Higher Casimirs

From the string point of view it is natural to ask if we could have higher ramification

points and higher genus pinched surfaces. These occur when higher Casimir perturbations are added. For the fundamental Casimirs, a simple scaling $t_k C_k(R) = \frac{\lambda_k C_k(R)}{N^{k-1}}$, where λ_k is kept fixed as $N \rightarrow \infty$, allows an interpretation in terms of branch points, tubes and handles. Requiring that an interpretation in terms of *orientable* worldsheets be possible implies a symmetry of Casimirs:

$$C_k(R, N) = (-1)^{k+1} C_k(\tilde{R}, -N), \quad (6.23)$$

Here \tilde{R} is the rep corresponding to the Young diagram which is the transpose of R . The symmetry can be proved using a set of diagrammatic rules for the conversion of Casimirs to characters of symmetric groups described in sec. 4.10 and in [88]. These rules can also be used to compute the class algebra of symmetric groups, which is related to the counting of covers with inverse automorphisms and to the collision of branch points [183].

For products of Casimirs, a simple string interpretation is possible if the coupling to products of Casimirs is scaled by a higher power of N^2 than the product of scalings for the factors. The singular worldsheet configurations contributing to the partition function of the theory with higher Casimirs involve tubes connecting more than two sheets, and higher genus collapsed surfaces (generalising the collapsed handles). The string interpretation of higher Casimirs has also been studied in [88].

6.6.2. Nonperturbative corrections

There are corrections to the coupled expansion arising from the fact that we haven't treated the range of Young diagrams being summed exactly. The equation (6.20) sums over all Y_{n^+} and Y_{n^-} for given n^\pm , whereas the reps of $SU(N)$ are restricted to have not more than $N - 1$ rows. Such corrections were estimated to be $O(e^{-N})$ in [94,186], as expected for a string theory where $1/N$ is the coupling constant [191].

6.6.3. $O(N)$ and $Sp(2N)$ Yang Mills

Similar results on $1/N$ expansions have been obtained for other gauge groups [160,182]. In these cases the worldsheets are not necessarily orientable, and there is no analogue of the chiral and anti-chiral sectors. The maps involved are again branched covers, possibly with collapsed tubes, and a new ingredient, collapsed cross-caps. The combinatorics of the Ω factors are very similar to that of the coupled Ω factor for the unitary groups.

7. Euler characters

7.1. Chiral GT partition function

In this section¹¹ we make our first connection between the topology of Hurwitz space and YM_2 amplitudes. Consider the CGTS (6.14). As in 2D gravity, relations to topological field theory become most transparent in the limit $A \rightarrow 0$ where we have a topological theory in spacetime. Accordingly, we will study the series

$$Z^+(0, p, N) = 1 + \sum_{n=1}^{\infty} N^{n(2-2p)} \sum_{s_1, t_1, \dots, s_p, t_p \in S_n} \left[\frac{1}{n!} \delta(\Omega_n^{2-2p} \prod_{j=1}^p s_j t_j s_j^{-1} t_j^{-1}) \right]. \quad (7.1)$$

7.1.1. Recasting the CGTS as a sum over branched coverings

The first step in rewriting (7.1) is to count the weight of a given power of $1/N$. To this end we expand the Ω^{-1} point as an element of the free algebra generated by elements of the symmetric group,

$$\Omega_n^{-1} = 1 + \sum_{k=1}^{\infty} \sum'_{v_1 \dots v_k \in S_n} \left(\frac{1}{N} \right)^{\sum_{j=1}^k n - K_{v_j}} (v_1 v_2 \dots v_k) (-1)^k \quad (7.2)$$

where the primed sum means no $v_i = 1$. We could rewrite (7.1) by imposing relations of the symmetric group of S_n . However, we decline to do this and rather substitute the expansion (7.2) into (7.1) to obtain

$$Z^+(0, p, N) = 1 + \sum_{n=1}^{\infty} \sum_{L=0}^{\infty} N^{n(2-2p)} \sum_{s_1, t_1, \dots, s_p, t_p \in S_n} \sum_{v_1, v_2, \dots, v_L \in S_n} N^{\sum_{j=1}^L (K_{v_j} - n)} \left[\frac{d(2-2p, L)}{n!} \delta(v_1 v_2 \dots v_L \prod_{j=1}^p s_j t_j s_j^{-1} t_j^{-1}) \right] \quad (7.3)$$

where $d(m, L)$ is defined by

$$(1+x)^m = \sum_{L=0}^{\infty} d(m, L) x^L. \quad (7.4)$$

Explicitly we have

$$\begin{aligned} d(2-2p, L) &= (-1)^L \frac{(2p+L-3)!}{(2p-3)!L!}, & \text{for } p > 1 \\ d(0, L) &= 0, \text{ unless } L = 0 \\ d(2, L) &= 0, \text{ unless } L = 0, 1, 2. \end{aligned} \quad (7.5)$$

¹¹ Some of the text of this chapter has been cut and pasted from [52].

For $p > 1$, $|d(2 - 2p, L)|$ is the number of ways of collecting L objects into $2p - 2$ distinct sets. The equation (7.3) correctly gives the partition function for any p including zero and one. For example the vanishing of $d(0, L)$ for $L > 0$ means that in the zero area limit only maps with no branch points contribute to the torus partition function. For genus zero the vanishing of $d(2, L)$ for $L > 2$ means that only maps with no more than two branch points contribute to the CGTS for the sphere.

To each nonvanishing term in the sum (7.3) we may associate a homomorphism $\psi : F_{p,L} \rightarrow S_n$, where $F_{p,L}$ is an F group (5.1), since if the permutations $v_1, \dots, v_L, s_1, t_1, \dots, s_p, t_p$ in S_n satisfy $v_1 \cdots v_L \prod_{i=1}^p s_i t_i s_i^{-1} t_i^{-1} = 1$ we may define

$$\psi : \alpha_i \rightarrow s_i \quad \psi : \beta_i \rightarrow t_i \quad \psi : \gamma_i \rightarrow v_i \quad (7.6)$$

Moreover, if there exists a $g \in S_n$ such that $g\{v_1, \dots, v_L; s_1, t_1 \cdots s_p, t_p\}g^{-1} = \{v'_1, \dots, v'_L; s'_1, t'_1, \dots, s'_p, t'_p\}$ as ordered sets then by definition 5.2 the induced homomorphisms are equivalent. Using the exercise at the end of 5.2.2 the class of ψ will appear in the sum in (7.3) $n!/|C(\psi)|$ times, where $C(\psi)$ is the centraliser of ψ in S_n . Therefore, we may write (7.3) as

$$Z^+(0, p, N) = 1 + \sum_{n=1}^{\infty} \sum_{B=0}^{\infty} N^{n(2-2p)-B} \sum_{L=0}^B d(2 - 2p, L) \sum_{\psi \in \Psi(n, B, p, L)} \frac{1}{|C(\psi)|} \quad (7.7)$$

where $\Psi(n, B, p, L)$ is the set of equivalence classes of homomorphisms $F_{p,L} \rightarrow S_n$, with the condition that the γ_i all map to elements of S_n not equal to the identity. We have collected terms with fixed value of:

$$B \equiv \sum_{i=1}^L (n - K_{v_i}) \quad . \quad (7.8)$$

Now we use theorem 5.1 to rewrite the sum (7.7) as a sum over branched coverings. To do this we must make several choices. We choose a point $y_0 \in \Sigma_T$ and for each n, B, L, ψ we also make a choice of :

1. Some set S of L distinct points on Σ_T .
2. An isomorphism (5.2).

To each ψ, S we may then associate a homomorphism $\pi_1(\Sigma_T - S, y_0) \rightarrow S_n$. By theorem 5.1 we see that, given a choice of S , to each class $[\psi]$ we associate the equivalence class of a branched covering $f \in H(n, B, p; S)$, where $f : \Sigma_W \rightarrow \Sigma_T$. The genus of the covering surface $h = h(p, n, B)$ is given by the Riemann-Hurwitz formula, (5.4). Note that

the power of $\frac{1}{N}$ in (7.7) is simply $2h - 2$. Finally, the centralizer $C(\psi) \subset S_n$ is isomorphic to the automorphism group of the associated branched covering map f . The order of this group, $|\text{Aut } f|$, does not depend on the choice of points S used to construct f . Accordingly, we can write Z^+ as a sum over equivalence classes of branched coverings:

$$Z^+(0, p, N) = 1 + \sum_{n=1}^{\infty} \sum_{B=0}^{\infty} \sum_{L=0}^B \left(\frac{1}{N}\right)^{2p-2} d(2-2p, L) \sum_{f \in H(n, B, p; S)} \frac{1}{|\text{Aut } f|}. \quad (7.9)$$

7.1.2. Euler characters

We have now expressed the CGTS as a sum over equivalence classes of branched coverings. We now interpret the weights in terms of the Euler characters of the Hurwitz space, \mathcal{H} of (5.11).

To begin we write

$$d(2-2p, L) = \frac{(\chi_p)(\chi_p - 1) \cdots (\chi_p - L + 1)}{L!}, \quad (7.10)$$

where $\chi_p = 2 - 2p$. The RHS of (7.10) is the Euler character of the space $\mathcal{C}_L(\Sigma_T) = C_L(\Sigma_T)/S_L$. This may be easily proved as follows. Recall that it is a general property of fiber bundles E with connected base that the Euler character is the product of Euler characters of the base and the fiber [198][42]:

$$\chi(E) = \chi(F)\chi(B)$$

under very general assumptions about the base B and the fiber F .

Let $C_{m,n}(\Sigma_T)$ be the configuration space of n labelled points on a surface Σ_T of genus p with m fixed punctures. There is a fibration

$$\begin{array}{ccc} C_{L-1,1}(\Sigma_T) & \longrightarrow & C_{0,L}(\Sigma_T) \\ & & \downarrow \\ & & C_{0,L-1}(\Sigma_T). \end{array} \quad (7.11)$$

Using the product formula for Euler characters of a fibration we get

$$\chi(C_{0,L}(\Sigma_T)) = (2 - 2p - (L - 1))\chi(C_{0,L-1}(\Sigma_T)) \quad (7.12)$$

This recursion relation together with $\chi(C_{0,1}(\Sigma_T)) = \chi(\Sigma_T)$ gives $\chi(C_{0,L}(\Sigma_T)) = (\chi_p)(\chi_p - 1) \cdots (\chi_p - L + 1)$. But $C_{0,L}(\Sigma_T)$ is a topological covering space of $\mathcal{C}_L(\Sigma_T)$ of degree $L!$ so this leads to

$$\chi(\mathcal{C}_L(\Sigma_T)) = d(2 - 2p, L). \quad (7.13)$$

Using (7.13), we can further rewrite the CGTS as

$$Z^+(0, p, N) = 1 + \sum_{n=1}^{\infty} \sum_{B=0}^{\infty} N^{n(2-2p)-B} \sum_{L=0}^B \chi(\mathcal{C}_L(\Sigma_T)) \sum_{f \in H(n, B, p, S)} \frac{1}{|\text{Aut } f|} \quad (7.14)$$

Let us now return to the fibration (5.5). A straightforward calculation of the Euler character would give:

$$\begin{aligned} \chi(\mathcal{C}_L(\Sigma_T)) \sum_{f \in H(n, B, p, S)} 1 &= \chi(\mathcal{C}_L(\Sigma_T)) |H(n, B, p; S)| \\ &= \chi(H(n, B, p, L)) \end{aligned} \quad (7.15)$$

where we have again used the fact that the Euler character of a bundle is the product of that of the base and that of the fiber [198] (the Euler character of the fiber is $\chi(H(n, B, p; S)) = |H(n, B, p; S)|$). What actually arises in the YM_2 path integral is a related sum weighted by $1/|\text{Aut } f|$. This is a very encouraging sign. When $H(n, B, p, L)$ contains coverings with automorphisms the corresponding space \mathcal{H} has orbifold singularities. In the string path integral the moduli space of holomorphic maps arises in the form \mathcal{H} , thus the occurrence of orbifold Euler characteristics of \mathcal{H} is a clear indication of a string path integral reinterpretation of Z . We introduce the orbifold Euler character $\chi_{\text{orb}}(H)$ as the Euler character of $\chi(\mathcal{H})$ calculated by resolving its orbifold singularities. The division by the factor $|\text{Aut } f|$ is the correct factor for calculating the orbifold Euler characteristic of the subvariety associated to $H(n, B, p, L)$ since $\text{Aut } f$ is the local orbifold group of the corresponding points in \mathcal{H} . With this understood we naturally define:

$$\chi_{\text{orb}}((H(n, B, p, L))) \equiv \chi(\mathcal{C}_L(\Sigma_T)) \sum_{f \in H(n, B, p, S)} \frac{1}{|\text{Aut } f|} \quad (7.16)$$

in the general case. Thus we finally arrive at our first main result:

Proposition 7.1. The CGTS is the generating functional for the orbifold Euler characters of the Hurwitz spaces:

$$Z^+(0, p, N) = 1 + \sum_{n=1}^{\infty} \sum_{B=0}^{\infty} \left(\frac{1}{N}\right)^{2h-2} \sum_{L=0}^B \chi_{\text{orb}}(H(n, B, p, L)) \quad (7.17)$$

where h is determined from n, p and B via the Riemann-Hurwitz formula.

The $L = B$ contribution in the sum is the Euler character of the space of generic branched coverings. As described in section 5.6, compactification of this space involves

addition of boundaries corresponding to the space of maps with higher branch points, i.e., where $L < B$. This leads to an interpretation of

$$\sum_{L=0}^B \chi_{\text{orb}}(H(n, B, p, L)) \quad (7.18)$$

as the Euler character of a partially compactified Hurwitz space $\overline{(H(n, B, p))}$ obtaining by adding degenerations of type 1 and 2 (see fig. 21) and their generalizations. Thus, we obtain the Euler character of the space of *all* holomorphic maps from a smooth worldsheet.

Proposition 7.2: The CGTS is the generating functional for the orbifold Euler characters of the analytically compactified Hurwitz spaces:

$$\begin{aligned} Z^+(0, p, N) &= 1 + \sum_{n=1}^{\infty} \sum_{B=0}^{\infty} \left(\frac{1}{N}\right)^{2h-2} \chi_{\text{orb}}(\overline{(H(n, B, p))}) \\ &= \exp \left[\sum_{h=0}^{\infty} \left(\frac{1}{N}\right)^{2h-2} \chi_{\text{orb}}(\mathcal{H}(\Sigma_W \rightarrow \Sigma_T)) \right] \end{aligned} \quad (7.19)$$

In the second line we have introduced the space of holomorphic maps, realized as in section 5.5, from a *connected* worldsurface of genus h . The exponentiation follows from the relation between moduli spaces of holomorphic maps from connected and disconnected worldsheets.

7.1.3. Connected vs. Disconnected surfaces

In this section we indicate an explicit combinatorial proof of the exponentiation in (7.19). In the equation (7.3) Z^+ contains contributions from all surfaces, connected and disconnected. For each n , the sum over S_n can be decomposed according to the number of components c of the worldsheet. For terms in the sum corresponding to covering surfaces with n sheets and c connected components, all the permutations in the delta function live in a product group $S_{n_1} \times S_{n_2} \times \cdots \times S_{n_c}$, where $n_1 + n_2 + \cdots + n_c = n$. Each permutation σ in the delta function is of the form $\sigma = \sigma^{(1)} \times \cdots \times \sigma^{(c)} \in S_{n_1} \times S_{n_2} \times \cdots \times S_{n_c}$, so the delta function factorises into a product of delta functions and $K_{(\sigma)} = K_{\sigma^{(1)}} + K_{\sigma^{(2)}} + \cdots + K_{\sigma^{(c)}}$. For each S_{n_k} ($k = 1, \cdots, c$) the permutations $s_1^{(k)}, s_2^{(k)}, \cdots, s_p^{(k)}, t_1^{(k)}, t_2^{(k)}, \cdots, t_p^{(k)}, v_1^{(k)}, \cdots, v_L^{(k)}$, generate the whole of S_{n_k} (the condition of transitivity or connectedness). The product group $S_{n_1} \times S_{n_2} \times \cdots \times S_{n_c}$ can be embedded in S_n in $\frac{n!}{n_1!n_2!\cdots n_c!} \frac{1}{c_1!c_2!\cdots c_k!}$ ways, where c_1 of the n_i 's are equal to one value, c_2 are equal to another etc. Since the sum in (7.3) counts *all* homomorphisms into S_n it sums over all the embeddings of the subgroups. This

guarantees that sums counting disconnected branched covers with fixed branch locus, with inverse automorphisms, factorise into a product over connected components. (Without the division by the automorphism group such sums do *not* exponentiate [103].) To complete a direct proof of the exponentiation, we need to write products like $d(x, L_1)d(x, L_2)$ in terms of sums over r of expressions containing $d(x, L_1 + L_2 - r)$. Such identities can be derived by a simple geometrical argument involving a stratification of products of configuration spaces by configuration spaces.

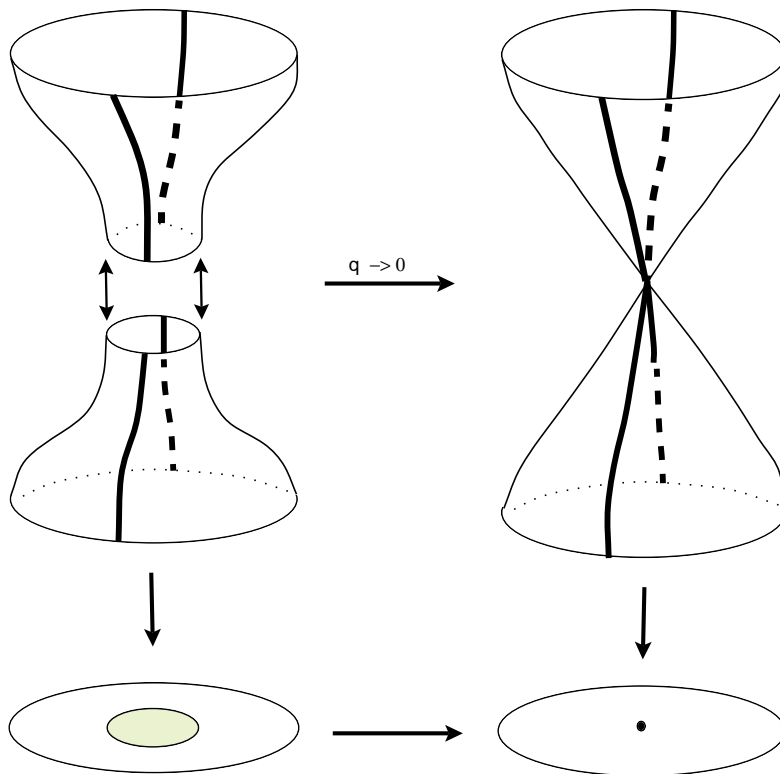

Fig. 23: Local model for a degenerating coupled cover with $n=2$. The region between stripes single-covers the annulus.

7.2. Nonchiral partition function

When writing the asymptotics for the full partition function similar - but more complicated - manipulations tell the same story [52]. Gross and Taylor showed that the $1/N$ expansion of Ω_{n+n-} admits a simple interpretation in terms of maps if the worldsheets are allowed to have collapsed handles. One interesting new point is that some new singular surfaces and maps contribute. These maps are neither holomorphic nor anti-holomorphic.

Pictorially, the singularity looks locally like fig. 23. Locally such maps are described by considering a plumbing fixture degenerating to the double point of Σ_W :

$$U_q = \{(z_1, z_2) | z_1 z_2 = \eta q, q \leq |z_1|, |z_2| < 1\} \quad (7.20)$$

where $0 \leq q < 1$ and η is an n^{th} root of unity for a positive integer n . On the plumbing fixture we have a family of covering maps

$$f^{q,n}(z) = \begin{cases} z_1^n & \text{for } q^{1/2} \leq |z_1| < 1 \\ \bar{z}_2^n & \text{for } q^{1/2} \leq |z_2| < 1. \end{cases} \quad (7.21)$$

In the limit $q \rightarrow 0$ we have a map which restricts to a holomorphic map from one disc and to an antiholomorphic map from another disc which is joined to the first at one point.

Details on the combinatorics of such maps are given in [52]. The expansion of the coupled Ω factors is understood in terms of Euler characters of configuration spaces for the motion of both branch points and images of double points [52]. The same ideas carry over to gauge groups $O(N)$ and $Sp(2N)$ where extra pointlike singularities also contribute (double points and collapsed cross-caps).

7.3. Inclusion of area

The same basic reasoning we have used in the $A = 0$ case can be applied to the $A > 0$ case. See [52].

8. Wilson loops

The ideas of the above sections generalize nicely to certain classes of Wilson loop amplitudes [94][52], but space precludes a detailed discussion here. Further results on the relations between Wilson loop amplitudes and covering spaces appear in [184].

9. Introduction to part II: General Remarks on Topological Field Theories

9.1. Cohomological Field Theories

In part II we review ‘‘cohomological field theory’’. Good reviews on the subject already exist [205,229,34,36,61], but no previous review (to our knowledge) presents the entire subject systematically from a unified point of view. We begin with some general remarks

on the subject. Topological field theories, largely introduced by E. Witten, may be grouped into two classes: “Schwarz type” and “cohomological type”.

“Schwarz type” theories [34] have Lagrangians which are metric independent and hence - formally- the quantum theory is expected to be topological. Examples of such theories include the $e^2 = 0$ YM_2 theory with Lagrangian

$$I = \int \text{Tr}(\phi F)$$

or 3D Chern-Simons theory

$$I = \int \text{Tr}(AdA + \frac{2}{3}A^3) \quad .$$

Mathematically such theories are related to flat connections, knot invariants, Knizhnik-Zamolodchikov equations, etc. Physically they are related to rational conformal field theories, the fractional quantum Hall effect, anyons etc. Some aspects of these theories are covered in J. Fröhlich’s lectures in this volume.

In these lectures we will focus on the second type of TFT’s - those of “cohomological type.” These have a very different flavor. They are not manifestly metric independent, but have a “BRST operator,” that is, an odd nilpotent operator, Q . Physical observables are Q -cohomology classes and amplitudes involving these observables are metric independent because of decoupling of BRST trivial degrees of freedom.

Cohomological field theory (CohFT) is of very broad significance - each of the examples of topological field theories has important applications to mathematics and physics. However, the true relevance of topological theories to more traditional problems in physics and quantum field theory remains to be seen. The main unsolved problem is whether these theories have anything definite and useful to say about “phases” of the theories with propagating degrees of freedom. There are many reasons why one might wish to study CohFT. Among these we mention the following four:

9.1.1. String reformulation of Yang-Mills

CohFT provides some new tools to attack this old problem. This is the primary motivation in these lectures. Having discovered in part I that YM_2 amplitudes are expressed in terms of topological invariants of Hurwitz moduli space we are motivated to search for a string theory with the property that

$$\int D[f, h_{\alpha\beta}, \dots] e^{-I[f, h_{\alpha\beta}, \dots]} = \chi_{\text{orb}}(\mathcal{H}(\Sigma_W, \Sigma_T)). \quad (9.1)$$

Here $f : \Sigma_W \rightarrow \Sigma_T$ and $h_{\alpha\beta}$ is a metric on Σ_W . CohFT provides just the right tools to construct the action I , as explained in chapter 18. In fact, one can go on and, for suitable compact Kähler manifolds X derive a theory, the “Euler σ -model”, $\mathcal{E}\sigma(X)$, whose partition function is given by

$$Z(\mathcal{E}\sigma(X)) = \chi_{\text{orb}}(\mathcal{H}(\Sigma_W, X)). \quad (9.2)$$

This reproduces the chiral expansion of QCD_2 . A similar construction with a different choice of section reproduces the orbifold Euler characters for the non-chiral theory.

9.1.2. Calculation of Physical Quantities

Some physical quantities can be calculated using methods of CohFT. This occurs in studies of 4-dimensional string compactification and in studies of 4D Yang-Mills theory with extended supersymmetries ($N = 2$ or 4).

In the context of string compactifications, Yukawa couplings of effective field theories are related to quantum cohomology rings which are in turn related to symplectic Floer homology groups. Moreover, terms in the effective superpotential of compactified type II strings can be calculated from related topological string theories [31,5]. Finally, CohFT makes some aspects of the “mirror symmetry” phenomenon transparent [230].

4D supersymmetric Yang-Mills theory has recently begun to undergo a renaissance. CohFT has played some role in this development. In a recent paper [207] the partition functions of $N=4$ supersymmetric Yang-Mills theories (SYM) were computed on certain 4-manifolds and shown to satisfy the remarkable Montonen-Olive “ S -duality conjecture”. One important part of this story is that topologically twisted $N = 4$ SYM calculates the Euler character of the moduli space of anti-self-dual instantons [207]. This result is easily understood using the formalism we will develop below.

9.1.3. Interactions with mathematics

The subject of topological field theories of cohomological type should be more properly called “enumerative quantum field theory,” for it describes intersection theory in moduli spaces in the language of local quantum field theory. The moduli spaces that arise in physics are very canonical and fundamental objects.

9.1.4. A Deeper formulation of String theory

One compelling reason to study CohFT is that it might prove an essential tool in formulating a geometrical basis for string theory. Fundamental theories of physics are deeply related to both geometry and symmetry. This is true of the cornerstones of modern theoretical physics: general relativity and gauge theory. It is widely believed that relativity and gauge theory are encompassed and profoundly generalized by string theory. Known results in string theory do indicate that it is a theory combining geometry and symmetry in a fascinating, new, and not yet understood way.

The problem of finding a geometrical formulation of string theories is extremely difficult, and not terribly well-posed. We need to study simpler, but analogous theories. In standard formulations of string theory there are infinite numbers of fields/particles, and an infinite-dimensional and somewhat mysterious symmetry algebra. In a sense, most of these symmetries are “broken”. Witten has advocated [219,220] that topological string theory is another phase of ordinary string theory in which many more symmetries are unbroken and the spectrum is vastly simpler. For example, the graviton vertex operator is Q -exact, and hence graviton excitations can be considered to be pure gauge. Consequently general covariance is unbroken. One expects that the underlying geometrical significance of topological string theories will be easier to understand. Indeed, in some examples this has proven to be the case. (Chern-Simons as a topological open string [231] and “Kodaira-Spencer theory”[31].)

9.2. Detailed Overview

We begin our review by describing the “theory of topological field theory”. The essential mathematical elements in constructing cohomological field theories are:

- a.) Equivariant cohomology,
- b.) (Path) Integral representations of equivariant Thom classes.

In chapters 10, 11 and 14 we describe in general mathematical terms the abstract constructions underlying all topological field theories. The abstract discussion concludes in section 14.6 where we give a unified description of an arbitrary cohomological field theory. The remaining chapters illustrate the principles of chapters 10, 11 and 14 in several famous examples.

9.2.1. Equivariant cohomology

The mathematics of equivariant cohomology is described in chapter 10. Equivariant cohomology is the fundamental algebraic structure underlying cohomological field theory. This subject is related to constructions in topology involving classifying spaces BG associated to groups G . In a sense, cohomological field theory may be regarded as the study of $H^\bullet(BG)$ and related cohomologies using the language of local QFT.

9.2.2. Mathai-Quillen formalism

Topological field theory path integrals are integral representations of Thom classes of vector bundles in infinite dimensional spaces. This was first pointed out, in the context of Donaldson theory, in an important paper of M. Atiyah and L. Jeffrey [16]. In chapter 11 we describe the general construction of Gaussian shaped Thom classes due to Mathai and Quillen (MQ)[138]. We also describe the important ideas of localization. The key result is given in 11.10 in equation (11.45).

9.2.3. Applications: TFT's without Local Symmetry

The results of chapter 11 are applied in chapters 12 and 13 to write topological sigma models. In chapter 12 we show (following [34]) how many of the essential ideas of topological field theory are already contained in supersymmetric quantum mechanics.

9.2.4. Local Symmetry

In chapter 14 we come to grips with the more difficult issue of topological field theories with local gauge symmetries. We describe the construction of the “projection gauge fermion” in section 14.3. Using the ideas of this chapter we are able to summarize standard Faddeev-Popov gauge-fixing in a way that ties together nicely the two ways ghosts enter in gauge theories: through the path integral measure and through the purely algebraic BRST formalism. This is done in section 14.5.

9.2.5. The examples

The principles of chapter 14 are illustrated in three standard examples in chapters 15, 16 and 17, on topological Yang-Mills, 2D gravity, and topological string theory. Each theory is presented in a parallel way.

Finally, as mentioned above, we apply the formalism to the problems described in part I and derive the underlying string Lagrangian of YM_2 .

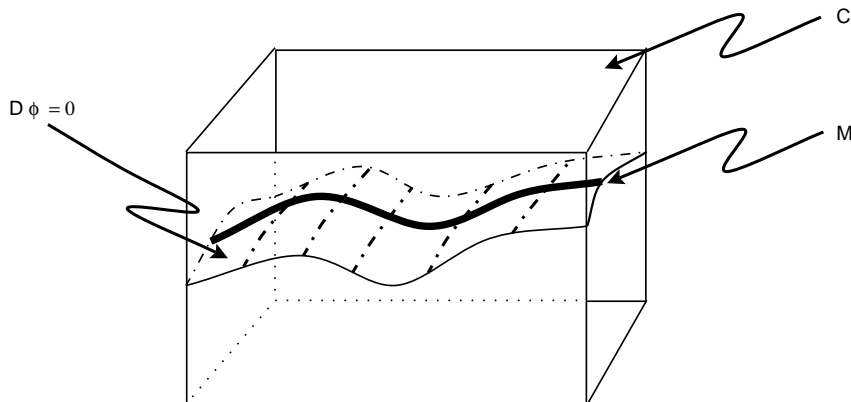

Fig. 24: The basic picture of moduli space. C is the space of fields, M above is a slice for moduli space.

9.3. Paradigm

We now describe the basic paradigm for topological field theories of cohomological type [229]. From a mathematical point of view, topological field/string theory is the study of intersection theory on moduli spaces using physical methods. In the physical framework these moduli spaces are presented in the general form:

$$\mathcal{M} = \{\varphi \in \mathcal{C} \mid D\varphi = 0\}/G \quad (9.3)$$

where \mathcal{M} is the moduli space, \mathcal{C} is some space of fields, D is some differential operator, and G is some group of local transformations. The basic picture for this situation is shown in fig. 24.

Thus we may characterize a theory by three basic data: symmetries, fields, and equations [229]. Let us explain the role of each of these elements in turn.

1. *Symmetries:* The symmetries will generally be characterized by an infinite-dimensional Lie group, for example a group of gauge transformations, or a diffeomorphism group. Having chosen the symmetry group G we study the G -equivariant cohomology.
2. *Fields:* When we study equivariant cohomology we must choose a model for the cohomology. A choice of differential complex amounts to a choice of fields.
3. *Equations:* Mathematically, the ultimate objects of study are intersection numbers. The equations are used to isolate interesting subspaces of \mathcal{C} . One writes Poincaré

duals to these subspaces using MQ representatives of Thom forms (thus introducing further fields). The equations are viewed as the vanishing of a section of a vector bundle: $s = 0$ where $s(\varphi) = D\varphi$ is the section of a vector bundle we will call the localization bundle: $s \in \Gamma[E_{\text{localization}} \rightarrow \mathcal{C}]$.

The above philosophy is given a precise meaning at the end of chapter 14 below.

9.3.1. General Remarks on Moduli Spaces

Moduli spaces of solutions to differential equations are pervasive in modern field theory. Examples include moduli spaces of instantons, monopoles, metrics, and holomorphic maps. These spaces are all of the form (9.3) and share three important properties: They are finite dimensional, generically noncompact, and generically singular.

The finite dimensionality means that the intersection theory has a chance of being well-defined. Nevertheless, noncompactness is a technical problem. Intersection numbers are not defined until one compactifies \mathcal{M} . Compactifications of \mathcal{M} are, in general, difficult to define and are also not unique. Furthermore topological answers depend on the compactification chosen. Singularities also pose technical problems. We have already seen orbifold singularities in Hurwitz space above.

10. Equivariant Cohomology

In this chapter we begin developing some of the crucial mathematical background for topological field theory. We begin with some of the algebraic structures in topological field theory. These, in turn, are related to deep constructions in topology. The reason for reviewing this material is that in all examples *the BRST operator of a topological field theory is the differential for a model of \mathcal{G} -equivariant cohomology of a space of fields.*¹²

10.1. Classifying Spaces

Let G be a group and \mathfrak{g} its Lie algebra. Some of what follows is only rigorously true when G is compact, but the formal discussion can be applied to any group. In particular, in topological field theory, it is applied to infinite dimensional groups.

¹² In some models \mathcal{G} is the trivial group.

A G -manifold M has an action $x \rightarrow g \cdot x$, for all $x \in M$ and $g \in G$. The action of G is said to be *free* if, for any $x \in M$,

$$g \cdot x = x \iff g = 1 \tag{10.1}$$

that is, there are no nontrivial isotropy groups. If the action of G is free on M , then the quotient space M/G forms the base space of a principal G bundle

$$\begin{array}{ccc} M & \longleftarrow & G \\ \downarrow \pi & & \\ M/G & & \end{array}$$

where the quotient space is smooth. In many cases of interest to physics and mathematics, the group action is not free. This leads to the considerations of 10.4 below.

Definition: To a group G we can associate the *universal G -bundle*, EG , which is a very special space, satisfying:

1. G acts on EG without fixed points.
2. EG is contractible.

Examples:

| G | EG | BG |
|--|---|--|
| \mathbb{Z} | \mathbb{R} | S^1 |
| \mathbb{Z}^n | \mathbb{R}^n | $S^1 \times \dots \times S^1$ |
| $U(1) = SO(2)$ | $S(H) = \lim_{n \rightarrow \infty} S^{2n+1}$ | $\mathbb{C}P^\infty = \lim_{n \rightarrow \infty} \mathbb{C}P^n$ |
| $U(k)$ | $V_k(H)$ | $G_k(H)$ |
| \mathcal{G} : local gauge transform | \mathcal{A} : Yang-Mills potentials | \mathcal{A}/\mathcal{G} |
| $\text{Diff}(\Sigma) \times \text{Weyl}(\Sigma)$ | $\text{MET}(\Sigma)$ | $\mathcal{M}_{h,0}$ |
| $\text{Mod}(\mathfrak{h},0)$ | Teichmüller | $\mathcal{M}_{h,0}$ |

The third and fourth rows are somewhat unfamiliar in physics, but the last 3 rows are quite familiar. Evidently, classifying spaces play an important role in physics.

Remarks:

1. EG is the “platonic G -bundle.” Any G bundle is a pullback:

$$\begin{array}{ccc} P \cong f^* EG & & EG \\ \downarrow & & \downarrow \\ M & \xrightarrow{f} & BG \end{array} \tag{10.2}$$

That is, we can find a copy of any conceivable G -bundle sitting inside $EG \rightarrow BG$ [111]. Moreover, isomorphism classes of bundles are in 1-1 correspondence with homotopy classes, $[f: M \rightarrow BG]$.

2. BG is unique up to homotopy type. EG is unique up to “equivariant homotopy type.” Recall that two spaces X and Y have the same homotopy type if there are maps $f: X \rightarrow Y$ and $g: Y \rightarrow X$ with fg and gf both homotopic to 1. The maps are said to be *equivariant* if they commute with the G -action.
3. There is an explicit combinatorial construction of EG for any topological group due to Milnor. See [111,199] for a description.
4. In the last three rows we have ignored an important subtlety, namely, that there are still fixed points. In the gravity case (last example) these arise from Riemann surfaces with automorphisms. By restricting to diffeomorphisms which preserve $H^\bullet(\Sigma_W, \mathbb{Z}_3)$ one can eliminate all fixed points [30]. In the Yang-Mills case (third from last example) one must divide the gauge group by its center (global \mathbb{Z}_N transformations, for $SU(N)$) and cut out the reducible connections described in chapter 15 below. The space of irreducible connections \mathcal{A}^{irr} is still contractible [11,67].

Exercise. *The contractible sphere*

Note that, among other things, the above examples assert that the unit sphere in Hilbert space:

$$\{(x_1, x_2, \dots) \in \ell_2(\mathbb{R}) \mid \sum x_i^2 = 1\} \tag{10.3}$$

is contractible! Prove this by first showing that the “Hilbert hotel map”

$$(x_1, x_2, \dots) \rightarrow (0, x_1, x_2, \dots) \tag{10.4}$$

is homotopic to 1. Then give a deformation retract of the “equator” $\{\vec{x}: x_1 = 0\}$ to the “north pole”, $(1, 0, \dots)$.

10.2. Characteristic classes

Let us review briefly some of the theory of characteristic classes. Although EG is contractible, it is a nontrivial bundle over BG . *Characteristic classes* are elements of the cohomology $H^\bullet(BG)$ which measure the twisting of the bundle. By the universal property, characteristic classes pull back to all G -bundles and measure twisting. Indeed, in a sense, all natural ways of measuring the topology of $P \rightarrow M$ are obtained by pullback from $H^\bullet(BG)$. (Making this statement precise would take us into category theory.)

Characteristic classes of $P \rightarrow M$ are formed from the field strengths $F \in \Omega^2(P, \underline{\mathfrak{g}})$ of a connection $A \in \Omega^1(P, \underline{\mathfrak{g}})$ on P . These satisfy:

$$\begin{aligned} dA &= F - \frac{1}{2}[A, A] \\ dF &= -[A, F] \end{aligned} \tag{10.5}$$

Let us form

$$\widetilde{ch}_n = \frac{1}{n!(2\pi i)^n} \text{Tr } F^n \in \Omega^{2n}(P)$$

Using (10.5) one easily shows that this is a closed form on P (the same is true for $\mathcal{P}(F)$, if \mathcal{P} is any invariant form on the Lie algebra $\underline{\mathfrak{g}}$). Since EG is contractible, its cohomology is trivial. Indeed \widetilde{ch}_n is exact:

$$\begin{aligned} \widetilde{ch}_n &= d\omega_{0,n} \\ &= d \left(\frac{1}{(n-1)!(2\pi i)^n} \sum_{i=0}^{n-1} \frac{1}{(n+i)} \text{Tr}[(dA)^{n-i-1}(A)^{2i+1}] \right). \end{aligned}$$

To get interesting cohomology we must discuss closed forms on BG . This leads to the notion of *basic forms*.

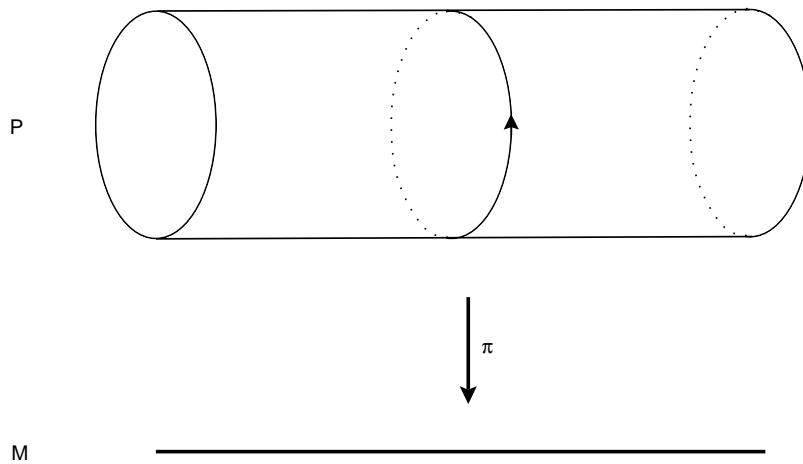

Fig. 25: Principal $U(1)$ bundle over M .

10.2.1. Basic Forms

Recall from A.3.2 that a principal bundle P has an action of $X \in \underline{\mathfrak{g}}$ on P via the vertical vector fields $\xi(X)$ (we will drop the ξ in our notation.) For example, for a principal $U(1)$ bundle the action looks like fig. 25. There are *two* associated actions of $\underline{\mathfrak{g}}$ on the differential forms $\Omega(P)$:

$$\begin{aligned} \iota(X): \Omega^k(P) &\rightarrow \Omega^{k-1}(P) && \text{contraction} \\ \mathcal{L}(X) \equiv [\iota(X), d]_+ : \Omega^k(P) &\rightarrow \Omega^k(P) && \text{Lie derivative} \end{aligned} \tag{10.6}$$

Forms $\tilde{\omega}$ on P which are of the form $\pi^*(\omega)$ for $\omega \in \Omega(M)$ are called “basic”. Such forms are characterized by

$$\begin{aligned} \iota(X)\tilde{\omega} &= 0 && \text{no vertical components} \\ \mathcal{L}(X)\tilde{\omega} &= 0 && \text{no vertical variation.} \end{aligned} \tag{10.7}$$

It is easily checked that \tilde{ch}_n are basic, so that $\tilde{ch}_n = \pi^*(ch_n)$. The forms ch_n define nontrivial cohomology classes on BG . It can be shown that the cohomology class is independent of the choice of connection A .

Remark: We have defined these classes using differential forms. In fact they can be defined purely topologically as elements of the *integral cohomology* $H^\bullet(BG; \mathbb{Z})$ [144].

10.3. Weil Algebra

We now introduce an algebraic analog of EG . We may view a connection as a map from the dual of the Lie algebra, $\underline{\mathfrak{g}}^*$, to a differential form:

$$\begin{aligned} A \in \Omega^1(P, \underline{\mathfrak{g}}) &\longleftrightarrow A: \underline{\mathfrak{g}}^* \rightarrow \Omega^1(P) \\ F \in \Omega^2(P, \underline{\mathfrak{g}}) &\longleftrightarrow F: \underline{\mathfrak{g}}^* \rightarrow \Omega^2(P) \end{aligned} \tag{10.8}$$

where $\underline{\mathfrak{g}}^*$ is the dual to $\underline{\mathfrak{g}}$. Let us return to (10.5). The reinterpretation (10.8) motivates the

Definition: The Weil algebra of $\underline{\mathfrak{g}}$ is the differential graded algebra (DGA)

$$\mathcal{W}(\underline{\mathfrak{g}}) = S(\underline{\mathfrak{g}}^*) \otimes \Lambda(\underline{\mathfrak{g}}^*)$$

where $S(\cdot)$ is the symmetric algebra and $\Lambda(\cdot)$ is the exterior algebra. It may be described in terms of generators by choosing a basis $\underline{\mathfrak{g}} = \{T_i\}$ and taking generators for $S(\underline{\mathfrak{g}}^*)$ given by

$\{\phi^i\}_{i=1,\dots,\dim G}$ of degree 2 and generators for $\Lambda(\underline{\mathfrak{g}}^*)$ given by $\{\theta^i\}_{i=1,\dots,\dim G}$, of degree 1. The Weil algebra becomes a differential algebra upon introducing the differential:

$$\begin{aligned} d_{\mathcal{W}}\theta^i &= \phi^i - \frac{1}{2}f^i_{jk}\theta^j\theta^k \\ d_{\mathcal{W}}\phi^i &= -f^i_{jk}\theta^j\phi^k \end{aligned} \tag{10.9}$$

where f^i_{jk} are the structure constants of $\underline{\mathfrak{g}}$. It may be seen that $d_{\mathcal{W}}$ is nilpotent, $d_{\mathcal{W}}^2 = 0$.

Remarks:

1. One could *define* a connection on P as a homomorphism $\mathcal{W}(\underline{\mathfrak{g}}) \rightarrow \Omega(P)$.
2. The Weil algebra may be thought of “more physically” in terms of “ b, c, β, γ systems” as follows. The space $S(\underline{\mathfrak{g}}^*)$ may be identified with the space of functions on the Lie algebra. We denote generators of the polynomial functions (with respect to the basis T_i) by γ^i , of degree two. Similarly $\mathcal{W}(\underline{\mathfrak{g}})$ may be identified with the space of functions on a superspace¹³ built from the tangent bundle of $\underline{\mathfrak{g}}$, $\hat{\underline{\mathfrak{g}}} = \Pi T\underline{\mathfrak{g}}$. The odd generators of functions on the tangent fibers are denoted by c^i . So a function on the superspace $\hat{\underline{\mathfrak{g}}}$ is a superfield

$$\Phi(\gamma^i, c^i).$$

This space of functions is graded. The grading is referred to as “ghost number” in physics. Now we introduce an algebra of operators on the space of functions:

$$[\beta_i, \gamma^j] = \delta_i^j \quad \{b_i, c^j\} = \delta_i^j \tag{10.10}$$

The action of the operator:

$$d_{\mathcal{W}} \rightarrow Q = -f^i_{jk}c^j\gamma^k\beta_i - \frac{1}{2}f^i_{jk}c^j c^k b_i + \gamma^i b_i \tag{10.11}$$

coincides with the Weil differential. Note that Q is very reminiscent of the form of “BRST operators” for supersymmetric gauge principles. We will comment further on this connection in section 10.8 below.

10.3.1. Basic subcomplex

The Weil algebra has properties analogous to those of EG . Just as EG is contractible, the cohomology of the Weil algebra is trivial:

$$H^\bullet(\mathcal{W}(\underline{\mathfrak{g}}), d_{\mathcal{W}}) = \delta_{\bullet,0}\mathbb{R}.$$

Exercise. *Trivial cohomology*

Show that the cohomology is trivial by choosing a different set of generators for $\mathcal{W}(\underline{\mathfrak{g}})$. (Hint: Use the first equation to make one generator exact).

¹³ The Π indicates that the fiber is considered odd. See, for example, [136].

To get interesting cohomology we take our cue from the theory of characteristic classes reviewed above and introduce two differential operators on $\mathcal{W}(\underline{\mathfrak{g}})$: the interior derivative, I_i , and Lie derivative, L_i , defined by their actions on the generators:

$$\begin{aligned} I_i \theta^j &= \delta_i^j \\ I_i \phi^j &= 0 \\ L_i &:= [I_i, d_{\mathcal{W}}]_+ \end{aligned} \tag{10.12}$$

I_j has degree -1 while L_j is of degree zero.

Definition: An element $\eta \in \mathcal{W}(\underline{\mathfrak{g}})$ will be called

- a. *Horizontal* if $\eta \in \cap_{i=1}^{\dim G} \ker(I_i)$,
- b. *Invariant* if $\eta \in \cap_{i=1}^{\dim G} \ker(L_i)$,
- c. *Basic* if η is both horizontal and invariant.

Exercise. *Action of L_i*

Show that L_i are the generators of the co-adjoint action of $\underline{\mathfrak{g}}$ on $\underline{\mathfrak{g}}^*$.

We denote the basic subcomplex of $\mathcal{W}(\underline{\mathfrak{g}})$ by $B\underline{\mathfrak{g}}$. It is straightforward to calculate $H^\bullet(B\underline{\mathfrak{g}})$, since on the basic subcomplex $d_{\mathcal{W}}$ is zero! Hence we need only determine explicitly $B\underline{\mathfrak{g}}$. Horizontality implies that we are in $S(\underline{\mathfrak{g}}^*)$, and invariance translates into invariance under the coadjoint action of $\underline{\mathfrak{g}}$ on $\underline{\mathfrak{g}}^*$. We denote the invariant elements under this G -action by $S(\underline{\mathfrak{g}}^*)^G$.

To summarize, we have:

$$\begin{aligned} B\underline{\mathfrak{g}} &= \mathcal{W}(\underline{\mathfrak{g}})_{\text{basic}} \\ H^\bullet(B\underline{\mathfrak{g}}) &= S(\underline{\mathfrak{g}}^*)^G \end{aligned}$$

These are the invariant polynomials on the Lie algebra $\underline{\mathfrak{g}}$, i.e., $B\underline{\mathfrak{g}}$ is the algebra of Casimir invariants. The relation between $B\underline{\mathfrak{g}}$ and BG is more than just an analogy:

Theorem 10.1: If G is a compact connected Lie group then $H^\bullet(BG) = H^\bullet(B\underline{\mathfrak{g}}) = S(\underline{\mathfrak{g}}^*)^G$.

For a proof see, for example, [12].

Example: $G = SO(2) = U(1)$. As we have already seen, the classifying space of $U(1)$ is $\mathbb{C}P^\infty$, whose cohomology is a polynomial algebra on a single generator, Ω , of degree two. Further $\underline{\mathfrak{g}} = u(1)$ has a single generator, so that

$$H^\bullet(\mathbb{C}P^\infty) = S(u(1)^*) = \mathbb{C}[\Omega]$$

Remark: Already in finite dimensions the theorem is not true for noncompact groups. A proper statement involves “continuous cohomology” [41]. In topological field theory the relevant groups are infinite dimensional and certainly not compact. Nevertheless, the cohomologies are remarkably close to those of related compact groups, although, as we will see, they involve spacetime in an interesting way (through the “descent equations”).

10.4. Equivariant Cohomology of Manifolds

Suppose a manifold M has a G -action. In general, there are fixed points and M/G is not a manifold. It is difficult to discuss the cohomology in such situations. A standard trick in algebraic topology is to replace

$$M \rightarrow EG \times M$$

This has a free G -action so

$$EG \times_G M \equiv \frac{EG \times M}{G},$$

where $g \cdot (e, x) = (eg^{-1}, gx)$, is a manifold. On the other hand, EG is contractible so $EG \times M \cong M$ in homotopy theory. Note, if the G action on M is free then indeed $EG \times_G M \cong M/G$ in homotopy theory. In general, we can regard $EG \times_G M$ as a bundle over BG with fiber M .

The above observations motivate the topological definition of equivariant cohomology:

Definition. The topological G -equivariant cohomology of M is

$$H_{G, \text{topological}}^\bullet(M) \equiv H^\bullet(EG \times_G M) \tag{10.13}$$

Note that $H_G^\bullet(pt) = H^\bullet(BG)$ is highly nontrivial!

As in our previous discussion, there is a corresponding algebraic description. Algebraically, the replacement $M \rightarrow EG \times M$ is analogous to

$$\Omega(M) \rightarrow \mathcal{W}(\mathfrak{g}) \otimes \Omega(M)$$

We must define *basic forms*. Let X_i be the vector fields on M corresponding to the action of $T_i \in \mathfrak{g}$.

Definition: Elements of $\eta \in \mathcal{W}(\mathfrak{g}) \otimes \Omega(M)$ will be called

- a. *Horizontal* if $\eta \in \cap_{i=1}^{\dim G} \ker(I_i \otimes 1 + 1 \otimes \iota(X_i))$,
- b. *Invariant* if $\eta \in \cap_{i=1}^{\dim G} \ker(L_i \otimes 1 + 1 \otimes \mathcal{L}(X_i))$,

c. *Basic* if η is both horizontal and invariant.

Definition: The algebraic G -equivariant cohomology of M is

$$H_{G,\text{algebraic}}^\bullet(M) \equiv H^\bullet((\mathcal{W}(\underline{\mathfrak{g}}) \otimes \Omega(M))_{\text{basic}}, d_T)$$

where

$$d_T = d_{\mathcal{W}} \otimes 1 + 1 \otimes d \tag{10.14}$$

is the differential.

Analogous to Theorem 10.1 above, we have:

Theorem 10.2 For G compact

$$H_{G,\text{topological}}^\bullet(M) = H_{G,\text{algebraic}}^\bullet(M)$$

Again, for further details, see [12].

Example: One of the most important cases for us is when $G = \text{Diff}(\Sigma) \times \text{Weyl}$, then, according to our table, $H_G^\bullet(pt) = H^\bullet(\mathcal{M}_{h,0})$. Clearly, G -equivariant cohomology is related to 2D topological gravity. If we let M be the configuration space of a sigma model, $\text{MAP}(\Sigma_W, X)$, then G -equivariant cohomology is related to 2d topological gravity coupled to a sigma model. The fact that $H_{S^1}^\bullet(pt) = \mathbb{C}[\Omega]$ is a polynomial algebra (with elements of arbitrarily high degree = ghost number) is probably related to the “special states” of $D \leq 2$ string theory [134].

10.5. Other formulations of equivariant cohomology

This section follows [114]. It is typical in mathematics that a given object, cohomology groups for example, can be characterized or formulated in many very different ways. This is true of equivariant cohomology. There are three algebraic models commonly encountered in the literature. The first model is the Weil model discussed above.

10.5.1. Cartan Model

The extreme simplicity of $B\underline{\mathfrak{g}}$ suggests that a complex much simpler than the Weil complex suffices.

- Complex:

$$S(\underline{\mathfrak{g}}^*) \otimes \Omega(M) \quad . \tag{10.15}$$

- Differential:

$$\begin{aligned}
d_c \phi^i &= 0 \\
d_c \eta &= (1 \otimes d - \phi^i \otimes \iota_i) \eta \\
&= (d - \iota_\phi) \eta
\end{aligned} \tag{10.16}$$

for $\eta \in \Omega(M)$. Note that $d_c^2 = -\phi^i \otimes \mathcal{L}_i$ and in general, d_c does not square to zero. On the invariant subcomplex defined by:

$$\Omega_G(M) \equiv (S(\underline{\mathfrak{g}}^*) \otimes \Omega(M))^G \tag{10.17}$$

it does square to zero: $d_c^2 = \phi^i \mathcal{L}_i \otimes 1 \rightarrow 0$. Elements of $\Omega_G(M)$ are called *equivariant differential forms*.

We will see

$$H^\bullet\left((\mathcal{W}(\underline{\mathfrak{g}}) \otimes \Omega(M))_{\text{basic}}, d_{\mathcal{W}}\right) \cong H^\bullet\left((S(\underline{\mathfrak{g}}^*) \otimes \Omega(M))^G, d_c\right) \tag{10.18}$$

as a special case of a more general result.

10.5.2. BRST Model

In the physical context of topological field theories it turns out that another model of equivariant cohomology arises naturally. This is called the “BRST model,” or, sometimes, the “intermediate model.” As a vector space, the complex of the BRST model is identical to that of the Weil model:

$$\mathcal{W}(\underline{\mathfrak{g}}) \otimes \Omega(M)$$

but now the differential d_B is:

$$d_B = d_{\mathcal{W}} \otimes 1 + 1 \otimes d + \theta^i \otimes \mathcal{L}_i - \phi^i \otimes \iota_i \tag{10.19}$$

with $d_B^2 = 0$. As in the Weil model, the cohomology of this complex is trivial. One must restrict to a subcomplex in order to calculate the equivariant cohomology. The analog of the basic subcomplex of the Weil model is in fact the subcomplex $(S(\underline{\mathfrak{g}}^*) \otimes \Omega(M))^G$ of the Cartan model. On this subcomplex we can clearly identify $d_c = d_B$ (and so $d_c^2 = 0$.)

10.5.3. Equivalences

It was shown by Kalkman that the BRST and Weil models of equivariant cohomology are related by the algebra automorphism of conjugation by $\exp(\theta^i \iota_i)$:

$$e^{\theta^i \iota_i} d_T e^{-\theta^i \iota_i} = d_B \tag{10.20}$$

where d_T is given by (10.14).

Exercise.

Prove (10.20) by computing separately $e^{\text{Ad } \theta^i \iota_i} d_{\mathcal{W}}$ and $e^{\text{Ad } \theta^i \iota_i} d$. Note that it follows immediately that $d_B^2 = 0$, something which is not manifest from (10.19).

Similar computations to those above show that

$$\begin{aligned} e^{\text{Ad } \theta^i \iota_i} [I_i \otimes 1 + 1 \otimes \iota_i] &= I_i \otimes 1 \\ e^{\text{Ad } \theta^i \iota_i} [L_i \otimes 1 + 1 \otimes \mathcal{L}_i] &= [L_i \otimes 1 + 1 \otimes \mathcal{L}_i] \end{aligned} \tag{10.21}$$

from which it follows that the basic subcomplex of the Weil model is mapped to the Cartan subcomplex in the BRST model. This proves (10.18).

Remark: A very similar conjugation appears in the papers [77,89] which relate the “string picture” and the “matter picture” of topological string theory (in the canonical formalism).

10.5.4. Axiomatic Formulation

The definition of equivariant cohomology can be axiomatized. We are here following [89]. It is not difficult to see that the equivariant cohomology groups satisfy the following three properties:

1. *Normalisation:* If the G -action is free, then $H_G^\bullet(M) \cong H^\bullet(M/G)$.
2. *Homotopy Invariance:* If $f: M_1 \rightarrow M_2$ is an equivariant map inducing a homotopy equivalence, then $f^*: H_G^\bullet(M_2) \rightarrow H_G^\bullet(M_1)$ is an isomorphism.
3. *Mayer-Vietoris:* If $M = U \cup V$, where U and V are invariant open submanifolds of M , then there is the long exact sequence

$$\begin{array}{ccccccc} \dots & \longrightarrow & H_G^{\bullet-1}(U) \oplus H_G^{\bullet-1}(V) & \longrightarrow & H_G^{\bullet-1}(U \cap V) & \longrightarrow & \\ \longrightarrow & H_G^\bullet(M) & \longrightarrow & H_G^\bullet(U) \oplus H_G^\bullet(V) & \longrightarrow & H_G^\bullet(U \cap V) & \longrightarrow \\ \longrightarrow & \dots & & & & & \end{array}$$

These three properties are all clear from the topological definition. In fact, they serve to characterize the cohomology groups uniquely and thus serve as an axiomatic definition of equivariant cohomology. Technically, equivariant cohomology is a contravariant functor from the category of G -manifolds to the category of graded vector spaces, $H_G^\bullet(M)$.

10.6. Example 1: S^1 -Equivariant Cohomology

10.6.1. Point

We have already seen $H_{S^1}^\bullet(pt) = \mathbb{C}[\Omega]$, where Ω is of degree two.

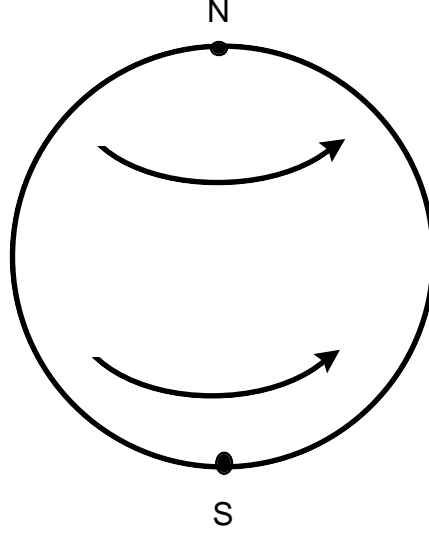

Fig. 26: Figure of S^2 with $U(1)$ action.

10.6.2. S^2

Consider the standard $U(1)$ action on the two-sphere, fig. 26. It is interesting to compare the different formulations here. From the axiomatic point of view we calculate the equivariant cohomology $H_{S^1}^\bullet(S^2)$ as follows. Introduce the standard open covering of S^2 by two disks: $U_1 = S^2 - \{\infty\}$ and $U_2 = S^2 - \{0\}$. Then the Mayer-Vietoris long exact sequence for the equivariant cohomology reads:

$$\begin{array}{ccccccc}
0 \rightarrow & H_{S^1}^0(S^2) & \longrightarrow & H_{S^1}^0(U_1) \oplus H_{S^1}^0(U_2) & \longrightarrow & H_{S^1}^0(U_1 \cap U_2) & \longrightarrow \\
\longrightarrow & H_{S^1}^1(S^2) & \longrightarrow & H_{S^1}^1(U_1) \oplus H_{S^1}^1(U_2) & \longrightarrow & H_{S^1}^1(U_1 \cap U_2) & \longrightarrow \\
\longrightarrow & H_{S^1}^2(S^2) & \longrightarrow & H_{S^1}^2(U_1) \oplus H_{S^1}^2(U_2) & \longrightarrow & H_{S^1}^2(U_1 \cap U_2) & \longrightarrow \\
\longrightarrow & \dots & & & & &
\end{array} \tag{10.22}$$

S^1 does not act freely on S^2 since the north and south poles are fixed points. S^1 does, however, have a free action on $U_1 \cap U_2$, so that by the normalisation axiom, $H_{S^1}^i(U_1 \cap U_2) = H^i(U_1 \cap U_2/S^1)$, which vanishes for $i \geq 1$. As a result (10.22) splits into subsequences:

$$\begin{array}{ccccccc}
0 \rightarrow & H_{S^1}^0(S^2) & \longrightarrow & H_{S^1}^0(U_1) \oplus H_{S^1}^0(U_2) & \longrightarrow & H_{S^1}^0(U_1 \cap U_2) & \longrightarrow \\
\longrightarrow & H_{S^1}^1(S^2) & \longrightarrow & H_{S^1}^1(U_1) \oplus H_{S^1}^1(U_2) & \longrightarrow & 0 & \longrightarrow \\
\longrightarrow & H_{S^1}^2(S^2) & \longrightarrow & H_{S^1}^2(U_1) \oplus H_{S^1}^2(U_2) & \longrightarrow & 0 & \longrightarrow \\
\longrightarrow & \dots & & & & &
\end{array} \tag{10.23}$$

For $i \geq 2$, we simply have

$$H_{S^1}^i(S^2) \cong H_{S^1}^i(U_1) \oplus H_{S^1}^i(U_2). \tag{10.24}$$

Using the axiom of homotopy invariance, we see that the maps $\varphi_i: U_i \rightarrow pt$ are equivariant maps which induce homotopy equivalences, so that $H^0 = \mathbb{C}$ and hence:

$$H_{S^1}^\bullet(S^2) \cong \{f(\Omega) \oplus g(\Omega) \in \mathbb{C}[\Omega] \mid f(0) = g(0)\} \quad (10.25)$$

where $\mathbb{C}[\Omega]$ is the polynomial algebra in a variable Ω of degree 2.

In terms of the Cartan model we begin by writing the Cartan differential as $d_C = d - \Omega \iota_{\partial/\partial\phi}$. Then $h_1(\Omega)(\alpha + \Omega \cos\theta) + h_2(\Omega)$ is a cohomology class, where α is the solid angle, in local coordinates: $d\phi d(\cos\theta)$. Remembering that Ω has degree 2, we recover the description (10.25) of the cohomology with $f(\Omega) = h_2(\Omega)$ and $g(\Omega) = h_2(0) + \Omega h_1(\Omega)$.

10.7. Example 2: \mathcal{G} -Equivariant cohomology of \mathcal{A}

We will discuss this in much greater detail in chapter 15, but for the present we note that the space of gauge connections, \mathcal{A} , on a principal bundle is the universal bundle for \mathcal{G} , the group of gauge transformations.

The Cartan model can be represented as

$$\begin{aligned} d_C A &= \psi \\ d_C \psi &= -D_A \phi \\ d_C \phi &= 0 \end{aligned} \quad (10.26)$$

where $\psi = \tilde{d}A$. In less condensed notation, $A_\mu^a(x)$ are ‘‘coordinates’’ on \mathcal{A} ; $\psi_\mu^a(x) = \tilde{d}A_\mu^a(x)$ are a basis of 1-forms; and $\phi^a(x)$ are functions on the Lie algebra.

Exercise.

- a.) Prove the second equation in (10.26).
- b.) Show that,

$$\begin{aligned} \mathcal{O}_2^{(0)}(P) &= \frac{1}{8\pi^2} \text{Tr} \phi^2(P) \\ \mathcal{O}_2^{(1)}(\gamma) &= \frac{1}{4\pi^2} \int_\gamma \text{Tr}(\phi\psi) \\ \mathcal{O}_2^{(2)}(\Sigma) &= \frac{1}{4\pi^2} \int_\Sigma \text{Tr}(\phi F - \frac{1}{2}\psi \wedge \psi) \end{aligned} \quad (10.27)$$

are closed equivariant forms on \mathcal{A} . Here P is a point in X , γ is a curve and Σ is a surface. We will return to these forms in several later sections.

10.8. Equivariant Cohomology vs. Lie-Algebra Cohomology

In the BRST quantization of gauge theories one works with Lie-algebra cohomology; in topological field theory one works with equivariant cohomology. It is natural to wonder how these two cohomologies are related to one another. It turns out that¹⁴ *equivariant cohomology of a Lie algebra $\underline{\mathfrak{g}}$ is the same as a “supersymmetrized” Lie algebra cohomology of a corresponding graded Lie algebra $\underline{\mathfrak{g}}_{\text{super}}$.*

10.8.1. Lie Algebra cohomology and BRST quantization

Let $\underline{\mathfrak{g}}$ be the Lie algebra spanned by T_i with $[T_i, T_j] = f^k{}_{ij} T_k$. The ordinary Lie algebra cohomology is defined using the complex $\Lambda^\bullet \underline{\mathfrak{g}}^*$. We can take generators to be anticommuting elements c^i of degree 1. The action of the differential is:

$$Q_{\underline{\mathfrak{g}}} c^i = -\frac{1}{2} f^i{}_{jk} c^j c^k \quad (10.28)$$

$Q_{\underline{\mathfrak{g}}}$ squares to zero by the Jacobi identity. Introducing a conjugate operator

$$\{b_i, c^j\} = \delta_i^j$$

we can write $Q_{\underline{\mathfrak{g}}} = -\frac{1}{2} f^i{}_{jk} c^j c^k b_i$. The cohomology of $Q_{\underline{\mathfrak{g}}}$, $H_{Q_{\underline{\mathfrak{g}}}}^\bullet(\underline{\mathfrak{g}})$, is the *Lie-algebra cohomology*.

Now let V be a $\underline{\mathfrak{g}}$ -module. We can define the Lie-algebra cohomology with coefficients in V , $H_{Q_{\underline{\mathfrak{g}}}}^\bullet(\underline{\mathfrak{g}}, V)$, by considering the complex

$$\Lambda^\bullet \underline{\mathfrak{g}}^* \rightarrow \Lambda^\bullet \underline{\mathfrak{g}}^* \otimes V \quad (10.29)$$

and the action of the differential

$$Q_{\underline{\mathfrak{g}}} \rightarrow c^i \otimes \rho(T_i) + Q_{\underline{\mathfrak{g}}} \quad (10.30)$$

where $\rho(T_i)$ is the representation of T_i in V . In more “physical ” notation we have:

$$Q_{\underline{\mathfrak{g}}} = c^i \rho(T_i) - \frac{1}{2} f^i{}_{jk} c^j c^k b_i \quad (10.31)$$

Example: One famous example is string theory where $\underline{\mathfrak{g}} = \text{Vir}(c)$ is the Virasoro algebra, where V is a representation provided by a CFT of central charge c . It is a well-known fact that $Q_{\underline{\mathfrak{g}}}$ only squares to zero for $c = 26$. In this case (as in the ordinary one) the cohomology defines the space of physical states.

Note that all the above goes through if we replace a Lie algebra by a super-Lie algebra. The ghosts c^i carry opposite statistics to the generators T_i .

¹⁴ We would like to thank G. Zuckerman for explaining this to us.

10.8.2. Supersymmetrized Lie Algebra cohomology

To the Lie algebra $\underline{\mathfrak{g}}$ we now associate a differential graded Lie algebra (DGLA) $\underline{\mathfrak{g}}[\epsilon] = \underline{\mathfrak{g}} \otimes \Lambda^* \epsilon$ where $\deg(\epsilon) = -1$ and $\deg(T_i) = 0$; ϵ is Grassmann, so $\epsilon^2 = 0$. The differential is defined by $\partial\epsilon = 1$. The DGLA, $\underline{\mathfrak{g}}[\epsilon]$, is generated by T_i and $\tilde{T}_i = T_i \otimes \epsilon$. It has structure constants:

$$\begin{aligned} [T_i, T_j] &= f^k{}_{ij} T_k \\ [T_i, \tilde{T}_j] &= f^k{}_{ij} \tilde{T}_k \\ [\tilde{T}_i, \tilde{T}_j] &= 0 \end{aligned} \tag{10.32}$$

The graded exterior algebra, $\Lambda^\bullet \underline{\mathfrak{g}}[\epsilon]^*$, may be identified with $S(\underline{\mathfrak{g}}^*) \otimes \Lambda(\underline{\mathfrak{g}}^*)$. Indeed it is generated by γ^i and c^i of degrees 2 and 1, respectively. The differential is defined by:

$$\partial^* c^i = \gamma^i \quad \partial^* \gamma^i = 0 \tag{10.33}$$

where ∂^* is dual to ∂ .

This super-Lie algebra has a BRST differential for $\underline{\mathfrak{g}}[\epsilon]$ -Lie-algebra cohomology. We introduce b_i and β_i in the usual way and get the differentials:

$$\begin{aligned} Q_{\underline{\mathfrak{g}}[\epsilon]} &= -f^i{}_{jk} c^j \gamma^k \beta_i - \frac{1}{2} f^i{}_{jk} c^j c^k b_i \\ \partial^* &= \gamma^i b_i \\ d_{\mathcal{W}} &= Q_{\underline{\mathfrak{g}}[\epsilon]} + \partial^*. \end{aligned} \tag{10.34}$$

where the last line makes use of the remark at the end of section 10.3.

Moreover, let V be a $\underline{\mathfrak{g}}$ -module. Then we can promote $V \rightarrow \Omega^\bullet(V)$ to get a $\underline{\mathfrak{g}}[\epsilon]$ -module with X and \tilde{X} acting by

$$X \rightarrow \mathcal{L}_X \quad X \otimes \epsilon \rightarrow \iota_X. \tag{10.35}$$

In fact, $(\Omega^\bullet(V), d)$ is a differential graded module (DGM) for the DGLA $\underline{\mathfrak{g}}[\epsilon]$. The total differential:

$$Q = c^i \mathcal{L}_i + \gamma^i \iota_i + Q_{\underline{\mathfrak{g}}[\epsilon]} + \partial^* \otimes 1 + 1 \otimes d \tag{10.36}$$

coincides with the ‘‘BRST’’ model differential of section 10.5.2!

10.9. Equivariant Cohomology and Twisted $N = 2$ Supersymmetry

Twisted $N = 2$ supersymmetry algebras are closely related to equivariant cohomology. For example, consider the twisted $N = 2$ supersymmetry algebra in two dimensions. The relations ¹⁵:

$$\begin{aligned}
[J_0, G_0] &= -G_0 & [\mathcal{J}, \iota_\xi] &= -\iota_\xi \\
[J_0, Q_0] &= +Q_0 & [\mathcal{J}, d] &= d \\
[G_0, Q_0] &= L_0 & [d, \iota_\xi] &= \mathcal{L}_\xi
\end{aligned} \tag{10.37}$$

show a perfect parallel with equivariant cohomology for an action generated by a single vector field ξ ; that is, for S^1 -equivariant cohomology. Here \mathcal{J} measures the degree of the form.

There is a beautiful generalization of this [194,200]. Consider the loop space of a manifold X , which we will denote LX . Consider differential forms on LX , denoted $\Omega^\bullet(LX)$. Formally we may think of $\Omega^\bullet(LX)$ as a continuous tensor product of forms on X : $\Omega^\bullet(LX) = \otimes_{\theta \in S^1} \Omega^\bullet(X)_\theta$. From this point of view we may speak of a “local degree” and a “local exterior derivative”. If $f(\theta)$ is a function on the circle we may form

$$\begin{aligned}
\text{deg}_f &\equiv \mathcal{J}_f \equiv \oint d\theta f(\theta) \tilde{d}X^\mu(\theta) \iota\left(\frac{\partial}{\partial X^\mu(\theta)}\right) \\
d_f &= \oint f(\theta) d\theta = \oint d\theta f(\theta) \tilde{d}X^\mu(\theta) \frac{\delta}{\delta X^\mu(\theta)}
\end{aligned} \tag{10.38}$$

On the other hand, there is a natural action of $G = \text{Diff}(S^1)$ on LX , and given an element of the Lie algebra, $v(\theta) \frac{\partial}{\partial \theta}$, there is a corresponding vector field

$$V = \oint v(\theta) \frac{\partial X^\mu(\theta)}{\partial \theta} \frac{\partial}{\partial X^\mu(\theta)}$$

on LX . Accordingly we have operators L_V and ι_V on $\Omega^\bullet(LX)$. One easily checks that these operators satisfy the algebra:

$$\begin{aligned}
[L_{V_1}, L_{V_2}] &= L_{[V_1, V_2]} & [\mathcal{J}_f, \mathcal{J}_g] &= 0 \\
[L_{V_1}, \iota_{V_2}] &= \iota_{[V_1, V_2]} & [\mathcal{J}_f, \iota_V] &= -\iota_{fV} \\
[L_V, d_f] &= -d_{f'V} & [\mathcal{J}_f, d_g] &= d_{fg} \\
[\iota_V, d_f]_+ &= L_{fV} - \mathcal{J}_V f' \\
[L_V, \mathcal{J}_f] &= -\mathcal{J}_V f'
\end{aligned} \tag{10.39}$$

¹⁵ Note that in this context L_0 denotes the zero mode of the bosonic stress-energy tensor.

Defining Fourier modes via $f_n = e^{in\theta}$, $v_n = e^{in\theta}$, we have:

$$\begin{aligned}
\mathcal{J}_{f_n} &\rightarrow \mathcal{J}_n \\
df_n &\rightarrow G_n^+ \\
\iota_{V_n} &\rightarrow -iG_n^- \\
L_{V_n} &\rightarrow -iL_n
\end{aligned} \tag{10.40}$$

in which case (10.39) becomes the topologically twisted $N = 2$ superconformal algebra with central extension $c = 0$. Recall that the twisted $N = 2$ algebra with central charge c is generated by L_m, J_m, G_m and Q_m with $m \in \mathbb{Z}$ and relations:

$$\begin{aligned}
[L_m, L_n] &= (m - n)L_{m+n} & [J_m, J_n] &= 0 \\
[L_m, G_n] &= (m - n)G_{m+n} & [J_m, G_n] &= -G_{m+n} \\
[L_m, Q_n] &= -nQ_{m+n} & [J_m, Q_n] &= Q_{m+n} \\
[G_m, Q_n]_+ &= 2L_{m+n} + nJ_{m+n} + \frac{1}{2}cm(m+1)\delta_{m+n,0} \\
[L_m, J_n] &= -nJ_{m+n} - \frac{1}{2}cm(m+1)\delta_{m+n,0}
\end{aligned} \tag{10.41}$$

See, for example, [133,209]. Putting $f = 1$ in (10.39) we see that \mathcal{J}_f , d_f , ι_v , and \mathcal{L}_v satisfy the basic relations needed to define $\text{Diff}(S^1)$ -equivariant cohomology.

10.10. Equivariant Cohomology and Symplectic Group Actions

Equivariant cohomology finds a very natural application in the important example of Hamiltonian actions of Lie groups G on symplectic manifolds (M, ω) , where $\omega = \frac{1}{2}\omega_{ij}dx^i dx^j$ is the symplectic form. In this case there are vector fields V_a acting on M :

$$[V_a, V_b] = f_{ab}^c V_c \tag{10.42}$$

with corresponding Hamiltonians generating the flows:

$$\iota_{V_a} \omega = -dH_a. \tag{10.43}$$

Equation (10.43) has a lovely reinterpretation in equivariant cohomology. Note that the Cartan differential becomes

$$D = d - \phi^a \iota_{V_a}. \tag{10.44}$$

The definition (10.43) is equivalent to the statement that $\omega - \phi^a H_a$ is an equivariantly closed form:

$$D(\omega - \phi^a H_a) = 0. \tag{10.45}$$

This will be useful in our discussion of localization below.

10.10.1. Case of YM_2

This remark becomes particularly interesting in the context of YM_2 . As we saw in subsection 3.6.1, \mathcal{A} carries a natural symplectic structure in $D = 2$. Here the moment map for the action of the group of gauge transformations is simply [11]:

$$\mu(A) = -\frac{1}{4\pi^2}F$$

so, from (10.27) we recognize $\mathcal{O}_2^{(2)}$ as the equivariant extension of the symplectic form.

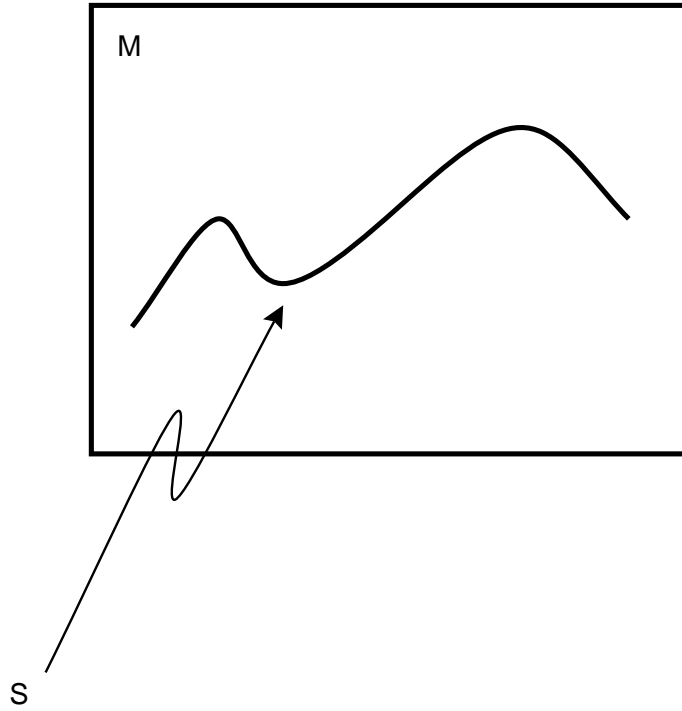

Fig. 27: Example of an inclusion.

11. Intersection Numbers and their Integral Representations

Let us return to the general picture of moduli spaces shown in fig. 24 of chapter 9. Relating the path integral over the fields \mathcal{C} to an integral over moduli space involves two steps: localization to $D\varphi = 0$ and projection by the gauge freedom. These steps correspond to the two basic ways in which spaces may be related to each other: inclusion and fibration, shown in fig. 27 and fig. 32, respectively. In cohomological field theory each of these steps is associated with a BRST principle.

In this chapter we will illustrate the first of the two basic constructions which allow us to write integrals over small spaces in terms of integrals over large spaces. In fig. 27 the basic problem is: given a cohomology class $\xi \in H^\bullet(M)$ and a submanifold $i : S \hookrightarrow M$ can we localize an integral over M to an integral over S ? The solution to this problem involves the construction of the Poincaré dual, $\eta[S \hookrightarrow M] \in H^\bullet(M)$, which satisfies:

$$\int_S i^*(\xi) = \int_M \xi \wedge \eta[S \hookrightarrow M] \quad (11.1)$$

So η is just a fancy version of a delta function. If S has codimension k then $\eta[S \hookrightarrow M] \in H^k(M)$.

Note that as a corollary of this remark if S_1, \dots, S_m intersect transversally and $\sum_{i=1}^m \text{codim } S_i = \dim M$ then

$$\int \eta_1 \wedge \dots \wedge \eta_m = \#(S_1 \cap \dots \cap S_m)$$

is the intersection number of the varieties.

11.1. Thom Class and Euler Class

11.1.1. Thom class

A central object of study in topological field theory is the Thom class of a vector bundle. From a Thom class we can construct Poincaré duals as well as Euler classes. We review briefly this notion in this subsection. This material is standard (an excellent textbook on the subject is [42]).

The cohomology of Euclidean space is $H^j(\mathbb{R}^n) = \delta_{j,0}\mathbb{R}$. It is possible to define another cohomology - cohomology with compact supports - by restricting to differential forms with compact support. For \mathbb{R}^n the cohomology groups are:

$$H_c^j(\mathbb{R}^n) \cong \delta_{j,n}\mathbb{R} \quad (11.2)$$

In physics a more natural notion than compact support is rapid decrease: i.e., Gaussian decay at infinity. Cohomology for forms with rapid decrease is the same as cohomology with compact supports [138], but the case of rapid decrease generalizes to quantum field theory. An explicit generator of the cohomology is:

$$\left(\frac{1}{\pi t}\right)^{n/2} e^{-(x,x)/t} dx^1 \wedge \dots \wedge dx^n. \quad (11.3)$$

Note that integration gives the explicit isomorphism in (11.2):

$$\eta \in H_{RD}^j(\mathbb{R}^n) \longmapsto \pi_* \eta = \int_{\mathbb{R}^n} \eta \in \mathbb{R}$$

If $E \rightarrow M$ is a vector bundle, with standard fiber V and fiber metric $(\cdot, \cdot)_V$, then one may also consider cohomology with rapid decrease along the fiber, $H_{VRD}(E)$. Thus, we only consider closed forms with Gaussian decay along the fiber directions and a form is only considered exact if it can be written as d of another form with rapid decrease.

Given the Gaussian decay along the fiber, we may define integration along the fiber:

$$\pi_*: \Omega_{VRD}^\bullet(E) \longrightarrow \Omega^{\bullet-n}(M)$$

where $n = \text{rank } E$.

There is a Poincaré lemma for the vertical rapid decrease cohomology:

Theorem: (Thom Isomorphism) For an orientable vector bundle $E \rightarrow M$ of rank n , integration along the fiber defines an isomorphism:

$$\pi_*: H_{VRD}^\bullet(E) \cong H^{\bullet-n}(M).$$

Proof: See Bott and Tu [42].

The image of $\mathbf{1} \in H^0(M)$ under π_*^{-1} determines a cohomology class

$$\pi_*^{-1}(\mathbf{1}) \equiv \Phi(E) \in H_{VRD}^n(E) \tag{11.4}$$

called the *Thom class* of the oriented vector bundle E . In terms of this class, the Thom isomorphism is given by

$$\begin{aligned} \mathcal{T}: H^\bullet(M) &\longrightarrow H_{VRD}^{\bullet+n}(E) \\ \mathcal{T}(\omega) &\longmapsto \pi^*(\omega) \wedge \Phi(E). \end{aligned} \tag{11.5}$$

In the following sections we will find explicit representatives of the Thom class.

11.1.2. Euler class

For an extensive discussion of the Euler class of a vector bundle see [42]. One quick way to define it is to introduce a connection ∇ compatible with a metric on E . The curvature F is an antisymmetric matrix of two-forms. The Pfaffian of an antisymmetric matrix A satisfies $\text{Pfaff}(A)^2 = \det A$ and may be defined by

$$\begin{aligned} \text{Pfaff}(A) &\equiv \frac{1}{m!2^m} \sum_{\sigma \in S_{2m}} \text{sign}(\sigma) A_{\sigma(1)\sigma(2)} \cdots A_{\sigma(2m-1)\sigma(2m)} \\ &\equiv \int d\rho \exp \frac{1}{2} \rho \cdot A \cdot \rho \end{aligned} \tag{11.6}$$

where the integral is over real Grassmann variables ρ .

The Euler class of E may be defined to be the cohomology class

$$e(E \rightarrow M) \equiv \left[\frac{1}{(2\pi)^m} \text{Pfaff}(F) \right]. \tag{11.7}$$

We will use variously the notations $e(E), \chi(E)$, for the Euler class of a vector bundle E . When we wish to emphasize the base space we will write $e(E \rightarrow M)$ and $\chi(E \rightarrow M)$.

11.1.3. Two key properties

The Thom class will be central to our discussion of topological field theory because of two key facts. We will derive these facts from the explicit (Mathai-Quillen) representative of $\Phi(E)$ below.

P1. *Euler Class.* Let $s: M \rightarrow E$ be any section of E , then $s^*(\Phi(E))$ is a closed form and its cohomology class coincides with the Euler class $\chi(E \rightarrow M) \in H^{2m}(M)$, where $2m$ is the rank of the vector bundle E . Note that if $\text{rank } E > \dim M$ then the Euler class is necessarily trivial.

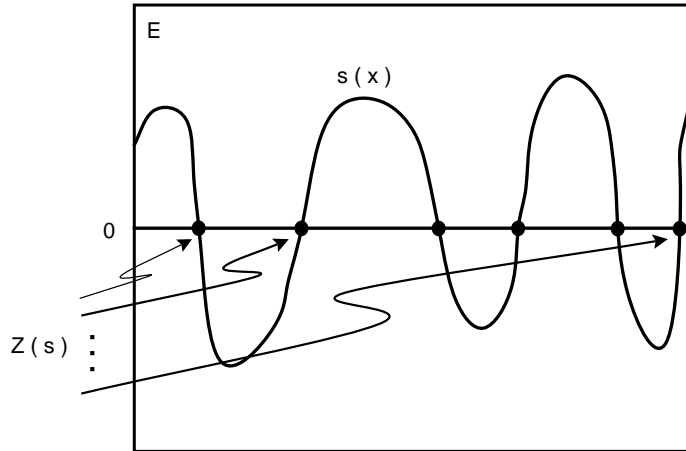

Fig. 28: The zero set of a generic section

P2. *Localization Property:* Let $\mathcal{Z}(s)$ denote the zero locus of a section s of E as in fig. 28. If s is a *generic* section¹⁶ then

$$\boxed{\int_{\mathcal{Z}(s)} i^* \mathcal{O} = \int_M s^*(\Phi(E)) \wedge \mathcal{O}} \quad (11.8)$$

That is, $s^*(\Phi(E)) = \eta[\mathcal{Z}(s) \rightarrow M]$. This makes sense since a generic section vanishes on a set of codimension $\text{rank } E$.

In the application to topological field theory one interprets $D\varphi$ in section 9.3 as a section of some vector bundle over the space of fields: $s(\varphi) = D\varphi$ defines $s \in \Gamma[E_{\text{localization}} \rightarrow \mathcal{C}]$. Then (11.8) is the key property allowing one to localize the integral to the subspace $D\varphi = 0$ in fig. 24. In topological field theory we often use nongeneric sections, in which case this equation receives an important correction described in section 11.10.3 below.

11.2. Universal Thom Class

We will now show how to construct a nice explicit representative for $\Phi(E)$ by first constructing a “universal” representative [138]. While E might be twisted and difficult to work with, we can replace constructions on E by equivariant constructions on a trivial bundle. Let E be an orientable real vector bundle of rank $2m$, with standard fiber V . Let $(\cdot, \cdot)_V$ be a nondegenerate bilinear form on V , defining an orthogonal group $G = SO(V)$ with Lie algebra $\underline{\mathfrak{g}}_s$. We can identify E as a bundle associated to a principal $SO(V)$ bundle $P \rightarrow M$, where P is the $SO(V)$ bundle of all orthonormal (ON) oriented frames on E :

$$\pi : P \times V \rightarrow E = \frac{P \times V}{G} \quad (11.9)$$

It is easier to work with the trivial bundle $P \times V$. Moreover, by (A.6) sections of E are simply G -equivariant functions, $P \rightarrow V$, and forms on E are identified with basic forms on $P \times V$:

$$\Omega^\bullet(E) \cong \Omega^\bullet(P \times V)_{\text{basic}}.$$

The correspondence between the DeRham theory on P and the Weil algebra, $\mathcal{W}(\underline{\mathfrak{g}}_s)$, which guided us in the previous chapter now suggests the definition:

¹⁶ Technically, if s is transversal to the zero section in E .

Definition: A form $U \in \mathcal{W}(\underline{\mathfrak{g}}_s) \otimes \Omega(V)_{\text{RD}}$ will be called a *universal Thom form* (in the Weil model) if it satisfies:

- (i) U is basic
- (ii) $QU = 0$, where $Q = d_{\mathcal{W}} + d$.
- (iii) $\int_V U = 1$

The reason U is useful is that if we choose a connection ∇ on E compatible with the fiber metric, then we can obtain a representative $\Phi(E, \nabla)$ of the Thom class as follows.

As we have noted, a connection on E , (equivalently, a connection on P) is the same thing as a choice of Weil homomorphism $w: \mathcal{W}(\underline{\mathfrak{g}}_s) \rightarrow \Omega(P)$. We then have a diagram:

$$\begin{array}{ccc}
 \mathcal{W}(\underline{\mathfrak{g}}_s) \otimes \Omega(V) & \xrightarrow{w} & \Omega(P \times V) \\
 \uparrow & & \uparrow \\
 (\mathcal{W}(\underline{\mathfrak{g}}_s) \otimes \Omega(V))_{\text{basic}} & \xrightarrow{w} & \Omega(P \times V)_{\text{basic}} \\
 & \searrow \bar{w} & \uparrow \pi^* \\
 & & \Omega(E)
 \end{array} \tag{11.10}$$

Applying the Weil homomorphism, w , to $U \in \mathcal{W}(\underline{\mathfrak{g}}_s) \otimes \Omega^\bullet(V)$ gives $w(U) \in \Omega^\bullet(P \times V)$. This form is basic and therefore $w(U) = \pi^*(\Phi(E, \nabla))$, that is,

$$\Phi(E, \nabla) = \bar{w}(U) \tag{11.11}$$

for some form $\Phi(E, \nabla) \in H_{V\text{RD}}^{2m}(E)$. Using the defining properties of the Thom class of E described in the previous section, we see that properties (i), (ii) and (iii) suffice to prove that $\bar{w}(U)$ represents the Thom class of E .

Remark: We have used here the Weil model of equivariant cohomology. One can also construct a universal class in the Cartan or BRST model, and we will do so below.

11.3. Mathai-Quillen representative of the Thom class

We first define the Mathai-Quillen (MQ) class. Then, by writing it in various ways we will show that it manifestly satisfies criteria (i), (ii) and (iii) above and hence represents the universal Thom class.

Let x^a be orthonormal (ON) coordinates for V and let $\theta^A \in \mathcal{W}^1(\underline{\mathfrak{g}}_s)$ and $\phi^A \in \mathcal{W}^2(\underline{\mathfrak{g}}_s)$ be generators of the Weil algebra of $\underline{\mathfrak{g}}_s = \mathfrak{so}(V)$. We will try to guess a form for an explicit universal Thom class. We know that Euler classes are given by Pfaffians of the curvature, so we start with

$$U \stackrel{?}{\sim} \text{Pfaff}(\phi)$$

but we need a form on V of rapid decrease, so given (11.3) we refine our guess to

$$U \stackrel{?}{\sim} \text{Pfaff}(\phi) e^{-(x,x)_V} dx^1 \wedge \dots \wedge dx^{2m}$$

This doesn't satisfy criterion (iii) above so we again refine our guess to:

$$U \stackrel{?}{\sim} \frac{1}{(2\pi)^m} \text{Pfaff}(\phi) e^{-(x,x)_V - (dx, \phi^{-1} dx)_V}$$

Finally a necessary condition for (i) is that U be horizontal, so introduce the notation $\nabla x = dx + \theta \cdot x$, where θ is the connection on V , i.e.

$$(\nabla x)^a = dx^a + \theta^A (T_A)^a_b \cdot x^b$$

and, finally, define the MQ representative:

$$\boxed{U = \frac{1}{(2\pi)^m} \text{Pfaff}(\phi) e^{-(x,x)_V - (\nabla x, \phi^{-1} \nabla x)_V} \in \mathcal{W}(\underline{\mathfrak{g}}_s) \otimes \Omega^\bullet(V)} \quad (11.12)$$

The ϕ^{-1} is slightly formal, but makes sense if one expands the exponential and combines with the Pfaffian.

Theorem [138]: U is a universal Thom class.

In the next two sections we will prove this theorem by checking properties (i), (ii) and (iii) of section 11.2. Clearly, U is $SO(V)$ invariant. Moreover, ∇x is horizontal:

$$\tilde{I}(X) \nabla x = X(x) + I_X(\theta)x = 0$$

so U is horizontal.¹⁷ Thus, U is basic, checking property (i). It is less evident that $\int_V U = 1$ and that U is closed. In order to make these properties manifest we proceed to integral representations of U . These integral representations are at the heart of the connection to TFT.

¹⁷ Recall that the action of T_A on V is given by $X_A = -(T_A)^a_b x^b \frac{\partial}{\partial x^a}$.

11.4. Integral Representation: Antighosts

We begin by introducing anticommuting orthonormal coordinates ρ_a for ΠV^* , where the Π signifies that the coordinates are to be regarded as anticommuting. In the field-theoretic context the ρ 's are the "antighosts." When we consider the complex $\Omega^\bullet(\Pi V^*)$ the ρ generate $\Omega^0(\Pi V^*)$ but will be considered to be of degree -1 . We now consider the form:

$$\exp\left[\frac{1}{4}(\rho, \phi\rho)_{V^*} + i\langle \nabla x, \rho \rangle\right] \in \mathcal{W}(\underline{\mathfrak{g}}_s) \otimes \Omega^\bullet(V) \otimes \Omega^\bullet(\Pi V^*)$$

where $\langle \cdot, \cdot \rangle$ is the dual pairing on V . We perform the Berezin integral over the ρ to get the (fermionic) integral representation of U :

$$\boxed{U = \frac{1}{\pi^m} e^{-(x,x)_V} \int_{\Pi V^*} d\rho \exp\left[\frac{1}{4}(\rho, \phi\rho)_{V^*} + i\langle \nabla x, \rho \rangle\right] \in \mathcal{W}(\underline{\mathfrak{g}}_s) \otimes \Omega^\bullet(V)} \quad (11.13)$$

From this representation it is obvious that $\int_V U = 1$. The reason is that to get a top form on V we have to take the term in the exponential with the top degree of dx . This also pulls off the top form in ρ . Then

$$\begin{aligned} \int_V U &= \frac{1}{\pi^m} \int_V \int_{\Pi V^*} d\rho e^{-(x,x)_V} \frac{i^{2m}}{(2m)!} (dx^a \rho_a)^{2m} \\ &= \frac{1}{\pi^m} \int_V dx^1 \wedge \dots \wedge dx^{2m} e^{-(x,x)} = 1 \end{aligned} \quad (11.14)$$

It remains to show that U is closed and defines an element of cohomology. For this we need the BRST integral representations.

Remarks:

1. A nice check on all this is to pull $\bar{w}(U)$ back by the zero section of E . Putting $x = 0$ in (11.13) gives a fermionic integral representation of a Pfaffian, hence:

$$s_0^* \bar{w}(U) = s_0^* \frac{1}{(2\pi)^m} \text{Pfaff}(F) = e(E)$$

recovering the Euler character from the pullback of the zero section.

2. We are using an ON set of coordinates ρ in writing the measure here. The measure is not invariant under general linear transformations and if in the basis ρ_a the metric on the fiber is G_{ab} , then the proper measure is $d\rho \sqrt{\det G}$.

11.5. Integral Representation: Q-Invariance

In order to write a manifestly closed expression for U we enlarge the equivariant cohomology complex to:

$$\mathcal{W}(\underline{\mathfrak{g}}_s) \otimes \Omega^\bullet(V) \otimes \Omega^\bullet(\Pi V^*) \quad (11.15)$$

and consider the following differential

$$Q_{\mathcal{W}} = d_{\mathcal{W}} \otimes 1 \otimes 1 + 1 \otimes d \otimes 1 + 1 \otimes 1 \otimes \delta \quad (11.16)$$

$d_{\mathcal{W}}$ is the Weil differential of chapter 10, while δ is the de Rham differential in ΠV^* . Explicitly:

$$\delta \begin{pmatrix} \rho_a \\ \pi_a \end{pmatrix} = \begin{pmatrix} 0 & 1 \\ 0 & 0 \end{pmatrix} \begin{pmatrix} \rho_a \\ \pi_a \end{pmatrix}$$

The grading, or ghost numbers of ρ and π are -1 and 0 , respectively.

Consider the “gauge fermion”

$$\Psi = -i\langle \rho, x \rangle + \frac{1}{4}(\rho, \theta \rho)_{V^*} - \frac{1}{4}(\rho, \pi)_{V^*} \in \mathcal{W}(\underline{\mathfrak{g}}_s) \otimes \Omega^\bullet(V) \otimes \Omega^\bullet(\Pi V^*) \quad (11.17)$$

which in orthonormal coordinates reads:

$$\Psi = -\rho_a(ix^a - \frac{1}{4}\theta^{ab}\rho_b + \frac{1}{4}\pi_a) \quad (11.18)$$

Expanding the action and doing the Gaussian integral on π leads to the third representation:

$$U = \int_{V^* \times \Pi V^*} \prod_{a=1}^{2m} \frac{d\pi_a}{\sqrt{2\pi}} \frac{d\rho_a}{\sqrt{2\pi}} e^{Q_{\mathcal{W}}(\Psi)} \quad (11.19)$$

The advantage of this representation is that

$$\int Q_{\mathcal{W}}(\dots) = (d + d_{\mathcal{W}}) \int(\dots) \quad (11.20)$$

which follows from the simple observation that

$$\delta = \pi_a \frac{\partial}{\partial \rho_a} \quad (11.21)$$

and hence $\int \delta(\dots) = 0$ by properties of the Berezin integral over ρ . Since the integrand is $Q_{\mathcal{W}}$ -closed, it immediately follows from (11.20) that U is closed in $\mathcal{W}(\underline{\mathfrak{g}}_s) \otimes \Omega^\bullet(V)$. Thus, we have finally proven that U satisfies criteria (i), (ii) and (iii) of section 11.2 and hence U is a universal Thom form.

11.6. Cartan Model Representative

A universal Thom form $U_{\mathcal{C}} \in (S(\underline{\mathfrak{g}}_s^*) \otimes \Omega(V))^G$ can also be constructed in the Cartan model of equivariant cohomology. $U_{\mathcal{C},t}$ is obtained by a differential on the complex $S(\underline{\mathfrak{g}}_s^*) \otimes \Omega^\bullet(V) \otimes \Omega^\bullet(\Pi V^*)$ defined by:

$$\begin{aligned} Q_{\mathcal{C}}x &= (d - \iota_\phi)x \\ Q_{\mathcal{C}} \begin{pmatrix} \rho_a \\ \pi_a \end{pmatrix} &= \begin{pmatrix} 0 & 1 \\ -\mathcal{L}_\phi & 0 \end{pmatrix} \begin{pmatrix} \rho_a \\ \pi_a \end{pmatrix} \end{aligned} \quad (11.22)$$

We then may take the much simpler gauge fermion:

$$\begin{aligned} U_{\mathcal{C},t} &= \frac{1}{(2\pi)^{2m}} \int_{V^* \times \Pi V^*} d\pi d\rho e^{Q_{\mathcal{C}} \left[\rho_a(-ix^a - t\pi_a) \right]} \\ &= \left(\frac{1}{4\pi t} \right)^m \int_{\Pi V^*} d\rho \exp \left[-\frac{1}{4t} (x, x)_V + i \langle \rho, dx \rangle + t (\rho, \phi\rho)_{V^*} \right] \end{aligned} \quad (11.23)$$

It may appear strange that we do *not* include the covariant derivative in x in this representation. When using this representation we must remember one subtlety in applying the analog of (11.10) to the Cartan model. The map:

$$(S(\underline{\mathfrak{g}}_s^*) \otimes \Omega(V), d_{\mathcal{C}}) \rightarrow (\Omega(P \times V), d).$$

given by naively applying the Weil homomorphism, so that $\phi \rightarrow F$, is *not* a chain map. For example, $d_{\mathcal{C}}\phi = 0$, while $dF = -[A, F]$. Given a connection on P we can define a horizontal projection of a form $\omega^{\text{horizontal}}(X_1, \dots, X_n) \equiv \omega(X_1^h, \dots, X_n^h)$. The map taking $\phi \rightarrow F$ and projecting on the horizontal component

$$((S(\underline{\mathfrak{g}}_s^*) \otimes \Omega(V))^G, d_{\mathcal{C}}) \rightarrow (\Omega(P \times V)_{\text{basic}}, d)$$

is a chain map and thus, in the Cartan model, the pullback of the Thom class becomes

$$w(U_{\mathcal{C},t})^{\text{horizontal}} = \pi^*(\Phi_t(E, \nabla)) \quad . \quad (11.24)$$

Remark: While the gauge fermion is much simpler in the Cartan model, one must, in principle, make a horizontal projection. This can be very awkward in gauge theories where the connection on the space of gauge potentials is nonlocal in spacetime. Nevertheless, the Cartan model is still used in topological gauge theories and string theories for reasons explained in chapter 14 below.

11.7. Other integral representations of U

The definitions of Q and of the gauge fermion are far from unique. Two representatives which appear in the literature are, first:

- Complex: $\mathcal{W}(\underline{\mathbf{g}}_s) \otimes \Omega^\bullet(V) \otimes \Omega^\bullet(\Pi V^*)$.
- Differential:

$$\begin{aligned}
 Q\theta &= \phi \\
 Q\phi &= 0 \\
 Qx^a &= \nabla x^a \\
 Q\rho_a &= \pi_a \\
 Q\pi_a &= \phi_{ab}\rho_b
 \end{aligned} \tag{11.25}$$

- Thom form:

$$U = \frac{1}{(4\pi)^{2m}} \int_{V \times \Pi V^*} d\rho d\pi e^{Q \left[\rho_a(-ix^a - \pi_a) \right]} \tag{11.26}$$

We have $Q^2 = \mathcal{L}_\phi$ so it is necessary to restrict to the G -invariant subcomplex to get a differential. This representative occurs, for example, in [36]. A second example is:

- Complex: $\mathcal{W}(\underline{\mathbf{g}}_s) \otimes \Omega^\bullet(V) \otimes \Omega^\bullet(\Pi V^*)$:
- Differential:

$$\begin{aligned}
 Qx^a &= dx^a \\
 Q\rho_a &= \bar{\pi}_a + \theta_a^b \rho_b \\
 Q\bar{\pi}_a &= -\phi_a^b \rho_b + \theta_a^b \bar{\pi}_b
 \end{aligned} \tag{11.27}$$

- Gauge fermion:

$$U = \frac{1}{(4\pi)^m} \int_{V \times \Pi V^*} d\rho d\pi e^{-Q \left[\rho_a(ix^a - \bar{\pi}_a) \right]} \tag{11.28}$$

This representation is used, e.g., in [219]. It is also more natural in supersymmetric quantum mechanics. It is simply related to the representation of section 11.5 by the shift: $\bar{\pi}_a = \pi_a - \theta_a^b \rho_b$.

11.8. Dependence on choices and “BRST Decoupling”

In constructing the form (11.19) we made many choices. We chose ON coordinates ρ_a to construct the measure $d\rho$; we chose a metric $(\cdot, \cdot)_V$ on V and we chose a specific gauge fermion (11.18). We now explain that these choices are unimportant.

The independence of choices follows from the basic principle of “BRST decoupling.” From the derivation of the universal Thom class, it is clear that any change in gauge fermion $\Psi \rightarrow \Psi + \Delta\Psi$ will produce a valid representative so long as 1.) The resulting U is basic, and 2.) U can be normalized to have integral one, i.e., $\int_V U \in \mathcal{W}(\underline{\mathbf{g}}_s)$ is a nonvanishing scalar.

One important aspect must be borne in mind when applying these rules to topological field theories. In TFT one is integrating over noncompact infinite-dimensional function spaces. In order to make precise statements it is necessary to impose boundary conditions. A change in Ψ can lead to a change in the “on-shell” value of π which in turn can bring in new Q fixed-points. (See section 11.10.4 below.) We will see an example of this in our discussion of supersymmetric quantum mechanics in section 12.6.

11.8.1. Independence of coordinates ρ_a

An important special case of the above remark is that the Thom class is independent of the metric on V . First, although we used an ON set of coordinates ρ_a , the superspace measure $d\rho d\pi$ is invariant under changes of coordinates $\rho \rightarrow A\rho, \pi \rightarrow A^{-1}\pi$ for all $A \in GL(V)$.

11.8.2. Independence of metric on V

Let us consider a more general gauge fermion: $\Psi = ic_1\langle\rho, x\rangle - c_2(\rho, \theta\rho)_{V^*} + c_3(\rho, \pi)_{V^*}$ and write $U = \int \exp[Q_{\mathcal{W}}(\Psi)]$ with $Q_{\mathcal{W}}$ defined as in (11.16). The resulting class U is automatically closed, but is basic iff $c_2 = -c_3$. In this case, letting $c_2 = t$ and absorbing c_1 into x we obtain the gauge fermion

$$\begin{aligned}\Psi_t &= -\rho_a(ix^a - t\theta^{ab}\rho_b + t\pi_a) \\ &= -i\langle\rho, x\rangle + t(\rho, \theta \cdot \rho)_{V^*} - t(\rho, \pi)_{V^*}\end{aligned}\tag{11.29}$$

and we can define the properly normalized universal Thom class as

$$U_t \equiv \left(\frac{1}{4\pi t}\right)^m \int d\rho \exp \left[-\frac{1}{4t}(x, x)_V + i\langle\rho, \nabla x\rangle + t(\rho, \phi\rho)_{V^*} \right]\tag{11.30}$$

The corresponding Thom class is denoted

$$w(U_t) = \pi^*(\Phi_t(E, \nabla)).\tag{11.31}$$

The parameter t may be interpreted as the scale of the metric $(\cdot, \cdot)_V$ on V .

11.9. Superspace and “physical notation”

11.9.1. Functions on superspace = Differential forms

Let us introduce the supermanifold \widehat{M} whose odd coordinates are generated from the fibers of T^*M . In local coordinates we may write (x^i, ψ^i) . A *function* on \widehat{M} is the same thing as a differential form on M . That is, we have the basic tautology:

$$\boxed{\hat{\mathcal{F}}(M) \equiv C^\infty(\widehat{M}) \cong \Omega^\bullet(M)} \tag{11.32}$$

the correspondence simply being given by $\psi^i \leftrightarrow dx^i$. While (11.32) is trivial, it is used repeatedly in the following.

If M is a manifold we may integrate differential forms of top degree, $\Omega^n(M)$, but in general we cannot integrate functions, since M has no natural measure. On the other hand \widehat{M} has a very natural measure:

$$\hat{\mu} = dx^1 \wedge \dots \wedge dx^n d\psi^1 \wedge \dots \wedge d\psi^n \tag{11.33}$$

Under changes of variables the Bose and Fermi determinants cancel¹⁸. If $\hat{\omega} \in C^\infty(\widehat{M})$ corresponds to the differential form ω then we have

$$\int_M \omega = \int_{\widehat{M}} \hat{\mu} \hat{\omega} \tag{11.34}$$

Thus, superspace integration is integration of differential forms.

Remark: Note that when pulled back by a section s , the expression $\int_M s^* \Phi_t(E, \nabla)$ is most naturally interpreted as an integral over the superspace \widehat{E}^* associated to the *total space* E^* .

11.9.2. Physical interpretation

Now we can outline how the form (11.13)(11.30) occurs in physics. The term in the exponential is an action. In physics the base manifold is a space of fields $\varphi \in \mathcal{C}$ and the section is typically of the form $D\varphi$ for some operator D . The first term in the action in

¹⁸ The supermanifold \widehat{M} is “split” so there is no subtlety here.

(11.30) is $(s, s)_V = |D\varphi|^2$ and gives the purely bosonic terms in the action. For examples we have

$$\begin{aligned} \|s(\varphi)\|^2 &= \int \sqrt{g} \operatorname{Tr} F^+(A)^2 && \text{in chapter 15} \\ &= \int \sqrt{\hbar} |df + Jdf\epsilon(h)|^2 && \text{in chapter 13} \end{aligned} \tag{11.35}$$

The term $\langle \nabla s, \rho \rangle$ gives the kinetic energy of the fermions. Recall that given a connection we have

$$\nabla s \in \Omega^1(\mathcal{C}; E).$$

Under the correspondence (11.32) $d\varphi \in \Omega^1(\mathcal{C})$ corresponds to a “ghost field” χ . We may write $\nabla s = \mathcal{D}\chi$ for some differential operator \mathcal{D} . Since ∇s is valued in E , \mathcal{D} is a map from ghosts to antighosts. Finally, $(\rho, \phi\rho)_{V^*}$ is a four-fermi interaction, since ϕ becomes the curvature of ∇ which, by the correspondence (11.32), is quadratic in χ .

Now let us interpret the parameter t in (11.29) and (11.30). By a rescaling of ρ we can bring t out in front of the action so that

$$Q\Psi_t = \frac{1}{t} \left[-\frac{1}{4} \|s(\varphi)\|^2 + \dots \right] \tag{11.36}$$

Thus we may identify t with \hbar or, alternatively, with a coupling constant in the physical model. As we will see in section 11.10 this implies that in these theories the semiclassical or weak-coupling expansion is exact.

The independence of cohomology classes from the *metric* of the fiber V also means that the energy-momentum tensor of the theory is a BRST commutator. For example, in (11.35) we see that the spacetime metric is used to define $(\cdot, \cdot)_V$.

11.10. The Localization Principle

11.10.1. Localizing support

We have shown many different ways to rewrite the MQ representative of the universal Thom class (11.12). In particular, we have written a family of representatives $\Phi_t(E, \nabla)$. From section 11.8 the cohomology class of $\Phi_t(E, \nabla)$ cannot depend on t . On the other hand, if we choose a limit representative with $t \rightarrow 0^+$ then the support of $s^*(\Phi_t(E, \nabla))$ will be sharply peaked on the zero-set of s . Consider the integral

$$\int_M s^*(\Phi_t) \mathcal{O} \tag{11.37}$$

where $\mathcal{O} \in H^\bullet(M)$. According to the method of steepest descents or stationary phase, the $t \rightarrow 0^+$ asymptotics of the integral are given by an integral along $\mathcal{Z}(s)$ and a Gaussian integration in the normal directions. In the limit $t \rightarrow 0^+$ the Gaussian approximation becomes arbitrarily good. On the other hand, from what we just said the integral cannot depend on t !

Therefore, the Gaussian approximation is exact.

11.10.2. Example: From Gauss-Bonnet to Poincaré-Hopf

We now work out the above principle for the case of $E = TM$ where M is a Riemannian manifold with metric g_{ij} . We take the Levi-Civita connection on TM . Let $V = V^i \partial_i$ be a section of TM . Then, considered as an element of $\mathcal{C}^\infty(\widehat{M})$,

$$\begin{aligned} V^*(\Phi_t(TM, \nabla)) &= \frac{1}{(4\pi t)^m} \int d\rho \sqrt{g} \exp \left[-\frac{1}{4t} g_{ij} V^i V^j + i \rho_j (\widehat{\nabla V})^j + t R_{ijkl} \rho^i \cdot \rho^j \psi^k \psi^l \right] \end{aligned} \quad (11.38)$$

where the $\widehat{}$ indicates that we are to think of the corresponding differential as a function on superspace. Setting $V = 0$, or taking $t \rightarrow \infty$, we get

$$\frac{1}{m!(2\pi)^m} \sqrt{g} \text{Pfaff}[g^{ii'} R_{i'j'} g^{j'j}] = \frac{1}{m!(2\pi)^m} \text{Pfaff}(R^i_j) \quad (11.39)$$

giving the Euler characteristic $\chi(TM) = \chi(M)$, expressed according to the Gauss-Bonnet formula.

On the other hand, letting $t \rightarrow 0^+$ we see that the integral

$$\begin{aligned} \int_{\widehat{M}} \hat{\mu} V^*(\Phi_t(TM, \nabla)) &= \frac{1}{(4\pi t)^m} \int dx d\psi d\rho \sqrt{g} \exp \left[-\frac{1}{4t} g_{ij} V^i V^j + i \rho_j (\widehat{\nabla V})^j + t R_{ijkl} \rho^i \cdot \rho^j \psi^k \psi^l \right]. \end{aligned} \quad (11.40)$$

is concentrated at the zeroes, P , of the vector field V . Let x^i be local coordinates in the neighborhood of a zero of V such that:

$$V^i = V^i_j x^j + \mathcal{O}(x^2) \quad (11.41)$$

We will assume that the zero is generic so that $\det V^i_j \neq 0$. Then at $x = 0$:

$$(\widehat{\nabla V})^i = V^i_j \psi^j + \mathcal{O}(x)$$

in the superspace language. Now do the integral (11.40) in the neighborhood of $x = 0$. As $t \rightarrow 0^+$ the Gaussian approximation gives an integral over ρ and ψ leading to a factor of

$$(-1)^m \sqrt{g} \det V_j^i$$

(The extra factor of \sqrt{g} arises because we are not using an orthonormal basis of ρ_i .) The bosonic Gaussian integral yields

$$\frac{1}{\sqrt{\det(V^{tr} g V)}}$$

Thus, *the boson and fermion determinants cancel up to sign* and the contribution of the fixed point is just

$$\text{sign} \det V_j^i = \text{ind}(V, P). \tag{11.42}$$

The index of V at P may be thought of more conceptually as the winding number of the map $S^{n-1} \rightarrow S^{n-1}$ given by a first order zero of V . Finally, since the Gaussian approximation is exact, (11.40) is just the sum over fixed points of the quantity (11.42). The t -independence of the integral proves the Poincaré-Hopf theorem. In summary we see that the MQ representative gives a formula for the Euler character that interpolates smoothly between the Gauss-Bonnet and Poincaré-Hopf formulae for $\chi(M)$:

$$\sum_{\{P|V(P)=0\}} \text{ind}(V, P) \quad \begin{array}{c} \swarrow \int \hat{\mu} V^*(\Phi_t) \\ \searrow \int_M e(TM) \end{array} \tag{11.43}$$

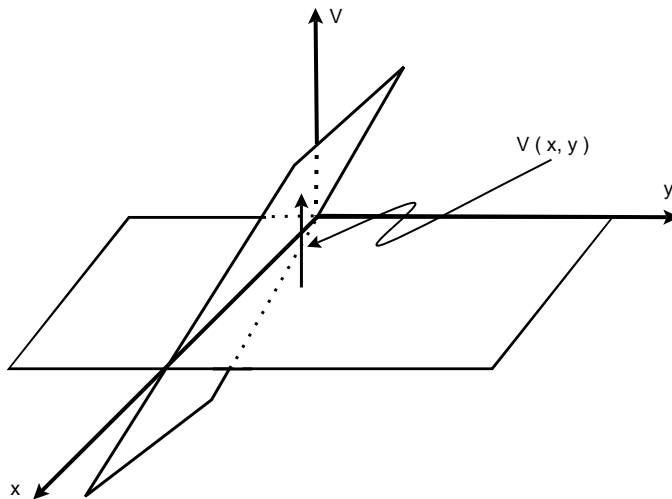

Fig. 29: A section with vanishing locus along the x -axis.

11.10.3. General Localization Formula

Consider the vector bundle

$$\begin{array}{ccc} E & \longleftarrow & V \\ \downarrow & & \\ M & & \end{array}$$

Let us now consider any section s of E , not necessarily generic. The proper statement of the localization formula is given in [225], sec. 3.3. Near the submanifold $\mathcal{Z}(s)$ we can choose coordinates (x, y) for M so that the equation $y^i = 0$ describes $\mathcal{Z}(s)$ locally as in fig. 29.

A section s may be written locally as $s(x, y) = (x, y; \vec{v}(x, y))$. We assume the section is not too special so that $\vec{v}(x, y)$ vanishes linearly at $y = 0$: $\vec{v}(x, y) = y^i \vec{v}_i(x) + \dots$. Let $E'_{x, y=0} = \text{Span} \{ \vec{v}_i(x) \}$, and consider the sequence of bundles over $\mathcal{Z}(s)$:

$$0 \rightarrow E' \rightarrow E \rightarrow E/E' \rightarrow 0 \quad (11.44)$$

It is shown in [225,224] that if P is Poincaré dual to $\chi(E/E' \rightarrow \mathcal{Z}(s))$ in $\mathcal{Z}(s)$, then $i(P)$ is Poincaré dual to $\chi(E \rightarrow M)$ in M . Translating this to a statement about cohomology we have:

$$\boxed{\int_M \chi(E \rightarrow M) \wedge \mathcal{O} = \int_{\mathcal{Z}(s)} i^*(\mathcal{O}) \wedge \chi(E/E' \rightarrow \mathcal{Z}(s))} \quad (11.45)$$

where $i: \mathcal{Z}(s) \hookrightarrow M$ is the inclusion.

This fact arises in applications to topological string theories as follows. As noted in section 11.9.2, the connection allows us to write $\nabla s \in \Omega^1(M; E)$. A 1-form with values in E can be regarded as a linear operator:

$$\nabla s : T_p M \rightarrow E_p \quad (11.46)$$

Over $\mathcal{Z}(s)$, we have

$$\nabla s|_{\mathcal{Z}(s)} = ds + \theta s|_{\mathcal{Z}(s)} = ds|_{\mathcal{Z}(s)}$$

Further given any tangent vector $V \in TM|_{\mathcal{Z}(s)}$ and section s , we may write in local coordinates:

$$\begin{aligned} V &= \xi^i \frac{\partial}{\partial x^i} + \zeta^i \frac{\partial}{\partial y^i} \\ s &= \vec{e}_\alpha s^\alpha \\ s^\alpha(x, y) &= v_i^\alpha y^i + O(y^2) \end{aligned}$$

so that

$$\begin{aligned}\nabla s|_{\mathcal{Z}(s)}(V) &= ds(V)|_{\mathcal{Z}(s)} \\ &= \vec{e}_\alpha v_i^\alpha \zeta^i\end{aligned}$$

If v_i^α is injective (giving precise meaning to “not too special” above (11.44)), then

$$\nabla s|_{\mathcal{Z}(s)}(V) = 0 \quad \iff \quad \zeta^i = 0$$

but such V are in $T\mathcal{Z}(s)$, so that

$$\ker(\nabla s)|_{\mathcal{Z}(s)} \cong T\mathcal{Z}(s). \quad (11.47)$$

That is, “the ghost zeromodes are tangent to $\mathcal{Z}(s)$.”

We can identify

$$E' = \text{Im}(\nabla s) \quad (11.48)$$

hence the exact sequence (11.44) becomes:

$$0 \longrightarrow E' \longrightarrow E \longrightarrow \text{cok}(\nabla s) \longrightarrow 0 \quad (11.49)$$

From the topological statement (11.45), we obtain:

$$\int_M s^*(\Phi(E, \nabla)) \wedge \mathcal{O} = \int_{\mathcal{Z}(s)} i^*(\mathcal{O}) \wedge \chi(\text{cok}(\nabla s) \rightarrow \mathcal{Z}(s))$$

(11.50)

Exercise. *Ghost number selection rule*

Show that \mathcal{O} must be a differential form of degree

$$\text{deg}(\mathcal{O}) = \text{ind}(\nabla s) \quad (11.51)$$

for (11.50) to be nonzero. Here $\text{ind}(T)$ for a linear operator T is the index:

$$\text{ind}(T) \equiv \dim \ker T - \dim \text{cok } T$$

In applications to TFT, ∇s is a Fredholm operator, so even though E and E' are infinite dimensional E/E' is finite dimensional.

The result (11.50), which will be very important in all the examples below, can also be proved directly from (11.30). If $\text{cok}(\nabla s) \neq 0$, then there will be *antighost zeromodes*. That is, some of the fermionic coordinates ρ cannot be absorbed by bringing down the kinetic term from the exponential. These must be absorbed by the curvature term. The fermionic integral computes the Pfaffian of the appropriate curvature, producing the RHS of (11.50).

Remarks:

1. Note that for a generic section $\text{coker } \nabla s = \{0\}$ and (11.50) reduces to (11.8) above. In this case χ is just ± 1 , and is determined by whether the isomorphism $\nabla s : TM/\ker \nabla s \rightarrow E$ is orientation preserving or reversing.
2. $\mathcal{Z}(s)$ might have many components. In QFT applications it will typically have infinitely many components.
3. The formula (11.50) can be generalized to the case where s vanishes quadratically in y . In that case there are further determinants.

11.10.4. Q Fixed-Points

The localization can also be understood from another point of view [225]. If the action of Q is free, then it determines an odd fibration of the supersymmetric field space, \widehat{E}^* . Any integral can then be broken up into an integral over the even base space times an integral over the odd fibre. Since in our case the argument of the integral is Q -invariant, the fibre integral gives the “volume” of the fibre. But this is zero, since

$$\int d\theta \, 1 = 0$$

for any Grassmann variable θ (collective coordinate for Q). Thus if Q acts freely, then integrals over Q -invariant observables vanish.

If Q acting on \widehat{E}^* has a fixed point set, \mathcal{Z} , then the entire contribution to the integral comes from the neighborhood of \mathcal{Z} .

Evidently, the fixed points of Q are:

$$\pi_a = 0 \qquad \psi^i \frac{\partial}{\partial \phi^i} s = 0$$

The second equation is solved by $\psi = 0$ in the directions normal to $\mathcal{Z}(s)$. Since π only enters through a Gaussian integral we can eliminate it by completing the square. Then the equation $\pi_a = 0$ becomes the nontrivial equation

$$\pi^j = -2\theta^{jk} \rho_k + \frac{i}{t} s^j = 0 \tag{11.52}$$

hence the fixed points are at $s^j = 0$, as expected.

11.10.5. Physical Interpretation

The Q fixed-point theorem, or localization theorem restricts fields $\phi \in \mathcal{C}$ to the classical solution space. The space $\mathcal{Z}(s)$ is a space of collective coordinates. $Qs = 0$ gives the equations for fermion zero modes which, under the superspace correspondence (11.32) correspond to cotangent vectors to $\mathcal{Z}(s)$. Q -invariance implies that Bose/Fermi determinants cancel up to sign simplifying the integral over collective coordinates. The equation (11.51) is related to anomalies in the conservation of a ghost number current.

11.11. Partition Functions

Suppose \mathcal{O}_i are closed forms on \mathcal{M} and that $\omega_i = i^*(\mathcal{O}_i)$ are forms on $\mathcal{Z}(s)$. Again $i: \mathcal{Z}(s) \hookrightarrow \mathcal{M}$ is the inclusion map. One elegant way to summarize the cohomology ring, or intersection ring of $\mathcal{Z}(s)$ is given by the generating functional: ¹⁹

$$\langle e^{\alpha^i \omega_i} \rangle_{\mathcal{Z}(s)} \equiv \int_{\mathcal{Z}(s)} e^{\alpha^i \omega_i} \chi(E/E' \rightarrow \mathcal{Z}(s)) \quad (11.53)$$

On the other hand, by (11.45) and (11.50) we can represent this as

$$Z(\alpha^i) = \int_{\hat{E}^*} \hat{\mu} e^{Q(\Psi) + \alpha^i \hat{\mathcal{O}}_i} \quad (11.54)$$

The “partition function” of the theory perturbed by operators $\hat{\mathcal{O}}_i$ is the generating functional of the cohomology ring of $\mathcal{Z}(s)$.

11.12. Localization and Integration of Equivariant Differential Forms

An illustration of the localization ideas used in this chapter is the localization proof of the Duistermaat-Heckman (DH) formula, and the generalization of this argument to the nonabelian localization theorem for integrals of equivariant differential forms [227].

¹⁹ We are looking at a generating functional for correlators. Adding the operators to the action might change the nature of the integral. In such cases one should take the α to be nilpotent.

11.12.1. *The Duistermaat-Heckman theorem*

Let (M, ω) be a symplectic manifold of dimension $2n$, with a Hamiltonian action of $U(1)$. Thus there is a vector field V generating the flows with Hamiltonian: $\iota_V \omega = -dH$. The DH theorem expresses

$$\int_M \frac{\omega^n}{n!} e^{\alpha H} \quad (11.55)$$

in terms of the critical points of H .

To prove the DH theorem let us recall from section 10.10.1 that $\omega + H$ is an equivariantly closed form for the equivariant differential $D = d + \iota_V$. (Here we have evaluated $\phi = -1$.) Let us rewrite (11.55) as

$$\left(\frac{1}{\alpha}\right)^n \int_M e^{\alpha(\omega+H)} \quad (11.56)$$

The proof of the localization theorem proceeds by considering the integral

$$\left(\frac{1}{\alpha}\right)^n \int_M e^{\alpha(\omega+H)+tD\lambda} \quad (11.57)$$

where λ is an invariant one-form. Using the basic fact that

$$\int_M \alpha D\beta = 0 \quad (11.58)$$

for an equivariantly closed α , and the fact that $D^2\lambda = \mathcal{L}_\phi\lambda = 0$ we see that (11.57) is t -independent and, in particular, is equal to (11.56). One way to prove the DH formula is now to choose the $U(1)$ -invariant one-form $\lambda = -g(V, \cdot)$ where g is a $U(1)$ -invariant metric²⁰. Then $D\lambda = d\lambda - g(V, V)$, so the $t \rightarrow \infty$ limit will localize the integral on $g(V, V) = 0$, i.e. at $V = 0$ [12,29].

We can put the integral (11.57) in the context of this chapter by translating to the superspace \widehat{M} , so $\widehat{\omega} = \frac{1}{2}\omega_{ij}\psi^i\psi^j$. We furthermore interpret D as a BRST operator, acting on equivariant differential forms: $D \rightarrow Q$. Then $\lambda = \psi^i\pi_i$ is interpreted as a gauge fermion Ψ . Thus the integral:

$$\left(\frac{1}{\alpha}\right)^n \int_{\widehat{M}} \widehat{\mu} e^{tD\lambda + \alpha(\omega+H)} = \int \widehat{\mu} e^{Q\Psi + \mathcal{O}} \quad (11.59)$$

is exactly of the form of a “partition function” for a “theory” with a Q -exact action as in the previous section!

²⁰ Any metric can be made $U(1)$ invariant by averaging.

We may immediately apply the Q -fixed-point theorem to prove the DH formula. The action of Q is given by $x^i \rightarrow \psi^i$, $\psi^i \rightarrow V^i$ and hence the Q -fixed points are $V^i(x) = 0$. In order to obtain the local factors we interpret the differential of Q as an operator on the local tangent space to \hat{M} . The result is the famous DH formula expressing $(\frac{1}{\alpha})^n \int_M e^{\alpha(\omega+H)}$ as a sum over the critical points of H .

For further discussion of interpretations of the DH formula, localization and relations to supersymmetric/BV geometry see [12,29,227,123,116,162,163] and references therein.

11.12.2. Nonabelian Localization

The localization proof of the Duistermaat-Heckman formula has a broad generalization [227,123]. Suppose X is a manifold (not necessarily symplectic) with an action of a group G . Consider an equivariant differential form $\alpha \in \Omega_G(X)$ (recall the definition in sec. 10.5.1.) Nonabelian localization simplifies integrals of the form

$$\int_X \alpha \in S(\underline{\mathfrak{g}}^*). \quad (11.60)$$

The integral (11.60) is a polynomial function on $\underline{\mathfrak{g}}$. One would like to integrate this over $\underline{\mathfrak{g}}$. Therefore a convergence factor is required:

$$\oint_{\epsilon, X} \alpha \equiv \frac{1}{\text{vol}G} \int_{\underline{\mathfrak{g}}} d\phi \int_X \alpha e^{-\frac{\epsilon}{2}(\phi, \phi)} \quad (11.61)$$

Here (\cdot, \cdot) is an invariant metric on $\underline{\mathfrak{g}}$, and $d\phi$ is the Euclidean measure on $\underline{\mathfrak{g}}$. This integration was introduced in [227] and is called integration of equivariant forms. It will be useful to us in chapter 14.

(11.61) satisfies the basic integration by parts property:

$$\oint_{\epsilon, M} \alpha D\beta = 0 \quad (11.62)$$

if α is equivariantly closed. Therefore by standard arguments:

$$\oint_{\epsilon, M} \alpha e^{tD\lambda} \quad (11.63)$$

is independent of t . Once again we introduce superspace notation and consider

$$\int d\phi \hat{\mu} \hat{\alpha} e^{tD\lambda - \epsilon \frac{1}{2}(\phi, \phi)} \quad (11.64)$$

We shall view this as a partition function in a cohomological field theory with $Q \longrightarrow D$ and gauge fermion $\Psi = \lambda$. The theory has been perturbed by the BRST invariant observable (ϕ, ϕ) . Localization follows in the standard way by comparing the $t \rightarrow 0$ and $t \rightarrow \infty$ limits. Choosing a gauge fermion $\lambda = \psi^i \pi_i(x)$ one can do the Gaussian ϕ -integral resulting in a suppression of the integrand by

$$\exp \left[-\frac{1}{2} t^2 \sum_a (V_a^i \pi_i)^2 \right] \quad (11.65)$$

where $V_a^i \partial_i$ are the vector fields corresponding to the action of generators of $\underline{\mathfrak{g}}$. It follows from (11.65) that the integral localizes at

$$\lambda(V_a) = V_a^i \pi_i = 0$$

This is the nonabelian localization theorem.

11.12.3. Application: Weak-coupling limit of YM_2

One application of the nonabelian localization theorem is a formula for the partition function of YM_2 [227]²¹. The key observation is that we can write the YM_2 partition function as

$$Z_{\text{physical}} = \frac{1}{\text{vol } \mathcal{G}} \int_{\text{Lie } \mathcal{G} \times \hat{\mathcal{A}}} d\phi \hat{\mu}_{\mathcal{A}} \exp \left\{ - \left[\frac{i}{4\pi^2} \int_{\Sigma} \text{Tr} (\phi F - \frac{1}{2} \psi \wedge \psi) \right] - \left[\epsilon \int_{\Sigma} \mu \frac{1}{8\pi^2} \text{Tr} \phi^2(P) \right] \right\} \quad (11.66)$$

where ϵ is related to the gauge coupling of chapter 4 by

$$e^2 = 2\pi^2 \epsilon \quad (11.67)$$

and $\hat{\mu}_{\mathcal{A}} = dAd\psi$ is the usual superspace measure. (11.66) coincides with the partition function of the theory because the integral over ψ is just such as to give the symplectic volume element on \mathcal{A} :

$$\int_{\hat{\mathcal{A}}} \hat{\mu}_{\mathcal{A}} \exp \left[\frac{i}{4\pi^2} \int_{\Sigma} \text{Tr} (\frac{1}{2} \psi \wedge \psi) \right] \leftrightarrow \frac{\omega^n}{n!} \quad (11.68)$$

²¹ An alternative approach to this result is discussed in [37].

The remaining action then coincides with (3.3).

Note that (11.66) is a special case of integration of equivariant differential forms for $\Omega_{\mathcal{G}}(\mathcal{A})$. Thus we can apply the nonabelian localization theorem. To do this we must introduce a Q -exact action from a \mathcal{G} -invariant one-form λ . In [227] the choice

$$\lambda = t \int \text{Tr } \psi * Df = t \int \mu \text{Tr } \psi^\alpha D_\alpha f \quad (11.69)$$

is made where f is defined in (3.1). Localization to $\lambda(V) = 0$ is then identical to localization to the solutions of the classical Yang-Mills equations. These consist of both flat and nonflat connections. For gauge group $SU(N)$ the latter have a field strength which can be put in the form $F = 2\pi\omega \text{Diag } \{n_1, n_2, \dots, n_N\}$, where $\sum n_j = 0$ and ω generates $H^2(\Sigma_T, \mathbb{Z})$. The action is $I = \frac{1}{\epsilon a} \sum n_i^2$. Thus nonabelian localization implies the important result that the $e^2 \rightarrow 0$ limit of Z is of the form

$$Z(e^2 a, \Sigma_T, SU(N)) \xrightarrow{e^2 \rightarrow 0} \int_{\mathcal{M}} \rho + \mathcal{O}(e^{-c/(\epsilon a)}) \quad (11.70)$$

where \mathcal{M} is the moduli space of flat connections discussed in sections 3.6 and (3.33). We will discuss ρ , which turns out to have *polynomial* dependence on ϵ , further in section 15.12.

12. Supersymmetric Quantum Mechanics

The subject of topological field theory may be traced back to Witten's fundamental work on dynamical supersymmetry breaking [215,216]. This work led naturally to a reformulation of DeRham theory and Morse theory in terms of supersymmetric quantum mechanics [217]. In turn Witten's formulation of Morse theory led to Floer's development of the homology theory that bears his name. Finally Floer homology of three-manifolds directly led to the formulation of Donaldson theory [14,218].

In this section we will present one of the simplest topological theories: Supersymmetric Quantum Mechanics (SQM)[215,216,3]. Supersymmetric quantum mechanics is discussed as an example of a topological field theory in [34]. The relation to the Mathai-Quillen formalism was pointed out in [39,36].

12.1. Action and Supersymmetry

Let X be a Riemannian manifold with metric $G_{\mu\nu}$. The degrees of freedom of supersymmetric quantum mechanics on X , $SQM(X)$, consist of a coordinate $\phi^\mu(t)$ on X and fermionic coordinates $\Psi^\mu(t)$ and $\bar{\Psi}^\mu(t)$, which together may be thought of as components of a superfield:

$$\Phi^\mu = \phi^\mu + \bar{\theta}\Psi^\mu + \theta\bar{\Psi}^\mu + \bar{\theta}\theta F^\mu \quad (12.1)$$

Here F^μ is an auxiliary field.

The action of $SQM(X)$ is given by:

$$I_{SQM} = \int dt \left(G_{\mu\nu} s^\mu s^\nu - i\bar{\Psi}_\mu D_t \Psi^\mu - \frac{1}{4} R^\mu{}_{\nu\rho\sigma} \bar{\Psi}_\mu G^{\nu\nu'} \bar{\Psi}_{\nu'} \Psi^\rho \Psi^\sigma \right) \quad (12.2)$$

where

$$\begin{aligned} s^\mu &= \dot{\phi}^\mu + G^{\mu\nu} \partial_\nu W \\ D_t \Psi^\mu &= \nabla_t \Psi^\mu + G^{\mu\nu} (\nabla_\nu \nabla_\lambda W) \Psi^\lambda \\ \nabla_t \Psi^\mu &= \frac{d}{dt} \Psi^\mu + \Gamma_{\nu\rho}^\mu \dot{\phi}^\nu \Psi^\rho \end{aligned} \quad (12.3)$$

and W is a *real*-valued function on X . Note the close resemblance to the MQ form of the previous section. Below we will make this correspondence exact.

The theory is, of course, supersymmetric and has a standard superspace construction which we will sketch in 12.4.5. If we make the field redefinition

$$\bar{F}_\mu = 2iG_{\mu\nu}(F^\nu + \dot{\phi}^\nu) + \partial_\lambda G_{\mu\nu} \Psi^\lambda \bar{\Psi}^\nu \quad (12.4)$$

the usual supersymmetry transformations take the simple form:

$$\begin{aligned} \mathbf{Q}\phi^\mu &= \Psi^\mu & \mathbf{Q}\Psi^\mu &= 0 \\ \mathbf{Q}\bar{\Psi}_\mu &= \bar{F}_\mu & \mathbf{Q}\bar{F}_\mu &= 0. \end{aligned} \quad (12.5)$$

Evidently $\mathbf{Q}^2 = 0$.

As emphasized in [34], SQM provides a simple example of a topological field theory. The nilpotent fermionic symmetry \mathbf{Q} can be interpreted as a BRST operator. (The proper physical interpretation of the BRST cohomology will appear below.) Moreover, (12.2), is derived from a \mathbf{Q} -exact action:

$$I_{SQM} = \int dt \left\{ \mathbf{Q}, \bar{\Psi}_\mu \left(i s^\mu + \frac{1}{4} G^{\lambda\mu} \bar{\Psi}_\kappa \Gamma_{\lambda\nu}^\kappa \Psi^\nu + \frac{1}{4} G^{\mu\nu} \bar{F}_\nu \right) \right\} \quad (12.6)$$

After integrating out \bar{F}_μ , to get

$$\bar{F}_\mu = -2(iG_{\mu\nu}s^\nu - \frac{1}{2}\Gamma_{\lambda\mu}^\nu\Psi^\lambda\bar{\Psi}_\nu) \quad (12.7)$$

we recover (12.2).

Topological invariance implies that the partition function

$$Z_{SQM} = \int e^{-I_{SQM}} \quad (12.8)$$

is a topological invariant, i.e. independent of any einbein one puts on the one-dimensional space, and, if X is compact, is independent of W . Since the action is \mathbf{Q} -exact, the reasoning of 11.10.4 shows that Z_{SQM} localizes on the set of \mathbf{Q} -fixed points. From (12.7) we have

$$\bar{F}_\mu = -2iG_{\mu\nu}\dot{\phi}^\nu + \Gamma_{\lambda\mu}^\nu\Psi^\lambda\bar{\Psi}_\nu - 2i\partial_\mu W.$$

It is apparent from (12.5) that the \mathbf{Q} -fixed points correspond to $\Psi^\mu = \bar{F}^\mu = 0$. This is the space of instantons given by

$$\mathcal{M} = \begin{cases} \{\phi^\mu \in \text{Map}(S^1, X) \mid \phi^\mu(t) = \text{constant}\} \cong X & \text{if } W = 0 \\ \{P \in X \mid dW(P) = 0\} & \text{if } W \neq 0 \end{cases} \quad (12.9)$$

Remark: The above formulae might appear unmotivated. They arise naturally from dimensional reduction $1 + 1 \rightarrow 0 + 1$ of the 2D nonlinear sigma model reviewed in section 12.4.5 below.

12.2. MQ interpretation of SQM

Many aspects of the general discussion of chapter 11 are explicitly realized in SQM, which may be viewed as the application of the MQ formalism to the infinite-dimensional geometry of the space of unbased (differentiable) loops in X :

$$LX \equiv \text{MAP}(S^1, X) \quad . \quad (12.10)$$

Heuristically, we may think of coordinates on this manifold as $\phi^\mu(t)$, $\mu = 1, \dots, \dim X$, and $t \in S^1$. The tangent space, corresponding to the spaces of small deformations $\delta\phi^\mu(t)$ of a loop, is identified with

$$T_\phi(LX) \cong \Gamma(\phi^*(TX)).$$

We will apply the MQ formalism to the bundle $E = T LX$. This bundle has a natural metric

$$(\gamma_1, \gamma_2)_\phi = \int_0^1 dt G_{\mu\nu}(\phi(t)) \gamma_1^\mu(t) \gamma_2^\nu(t) \quad . \quad (12.11)$$

In local coordinates, the metric is $G_{\mu\nu}(\phi(t_1))\delta(t_1 - t_2)$. The Riemannian geometry of LX is therefore almost identical to that of X , with some extra delta functions entering expressions when written in terms of local coordinates. For example, the Levi-Civita connection, ∇ , on LX is just the pullback connection from X . It acts on a vector field

$$V = \oint dt V^\mu(\phi, t) \frac{\partial}{\partial \phi^\mu(t)}$$

to produce

$$\nabla V = \oint dt_1 dt_2 \left[\frac{\delta V^\mu(\phi, t_1)}{\delta \phi^\nu(t_2)} + \Gamma_{\nu\lambda}^\mu(\phi(t_2)) V^\lambda(\phi, t_1) \delta(t_1 - t_2) \right] \frac{\partial}{\partial \phi^\mu(t_1)} \otimes \tilde{d}\phi^\nu(t_2)$$

where $\{\frac{\partial}{\partial \phi^\mu(t)}\}$ and $\{\tilde{d}\phi^\mu(t)\}$ are to be viewed as bases of $T LX$ and $T^* LX$, respectively. In local coordinates the curvature is just the curvature of X multiplied by δ -functions.

Having specified our connection we choose a section of E to be:

$$[s(\phi)]^\mu(t) = \dot{\phi}^\mu(t) + G^{\mu\nu} \partial_\nu W(t) \quad (12.12)$$

An easy calculation, using the basic tautology (11.32) to replace $\tilde{d}\phi^\mu(t) \rightarrow \Psi^\mu(t)$ shows that

$$\nabla s = \oint dt \left[\nabla_t \Psi^\mu + (\nabla^\mu \nabla_\lambda W) \Psi^\lambda \right] \frac{\partial}{\partial \phi^\mu(t)} \quad (12.13)$$

Identifying coordinates for the dual bundle ΠE^* as $\rho \rightarrow \bar{\Psi}_\mu(t)$, we see that $\langle \rho, \nabla s \rangle$ corresponds to the fermion bilinear terms in (12.2). The curvature produces the four-fermi term. Thus the SQM action (12.2) coincides exactly with the MQ formula. Moreover, the expression (12.6) for the action coincides with the gauge fermion (11.18). The differential is

$$\mathbf{Q} = \oint dt \left(\Psi^\mu(t) \frac{\partial}{\partial \phi^\mu(t)} + \bar{F}_\mu(t) \frac{\partial}{\partial \bar{\Psi}_\mu(t)} \right)$$

We now use the results of chapter 11 to compute the partition function, Z_{SQM} . In the fields-equations-symmetries paradigm the equations are the instanton equations $s^\mu(t) = 0$. The localization to the zeroes of s calculates the Euler character of an appropriate bundle over $\mathcal{Z}(s)$. For $W = 0$, X compact we have a nongeneric section: $\mathcal{Z}(s) = X$, the constant

loops. Acting on $T_\phi^* LX$ at a constant loop ϕ the operator ∇s is identified with $\frac{d}{dt}$ acting on periodic loops in $T_\phi X$. This operator has index

$$\text{ind } \frac{d}{dt} = 0 \quad \ker (\nabla s) \cong \text{cok } (\nabla s) \cong TX$$

so by (11.50) we have

$$Z_{\text{SQM}} = \int_X \chi(TX) \quad .$$

If W is a generic function, we have a generic section and the localization to the zeroes of s is the localization to constant loops mapping to critical points of W . The localization to $\mathcal{Z}(s)$ becomes the signed sum:

$$\sum_{\{P \in X \mid dW(P)=0\}} \text{sign} \left[\det \frac{\partial^2 W}{\partial \phi^\mu \partial \phi^\nu}(P) \right]$$

Note that this is just the sum of indices for the vector field ∇W . From either point of view we see that the partition function is given by

$$\boxed{Z_{\text{SQM}} = \chi(X)} \tag{12.14}$$

We will now verify (12.14) from a more physical point of view using the canonical quantization of $\text{SQM}(X)$.

12.3. Canonical Quantization

To describe the Hilbert space we represent the canonical commutation relations:

$$\begin{aligned} [\phi^\mu, \pi_\nu] &= i\delta_\nu^\mu \\ \{\bar{\Psi}_\mu, \Psi^\nu\} &= \delta_\mu^\nu \end{aligned} \tag{12.15}$$

where $\pi_\mu = 2G_{\mu\nu} \dot{\phi}^\nu + 2\partial_\mu W$ is the canonical momentum to ϕ^μ . The first line is represented in the standard way in terms of wavefunctions in $L^2(X)$. To represent the second line, which defines a Clifford algebra, we must choose a polarization, that is, a fermionic vacuum. We can make the choice that $\bar{\Psi}_\mu$ are annihilation operators:

$$\bar{\Psi}_\mu | 0 \rangle = 0$$

Then wavefunctions are functions $F(\phi, \Psi)$ of ϕ^μ and Ψ^μ , that is, functions on the superspace \hat{X} . The Hilbert space of the theory is then identified, by the basic tautology of section 11.9.1 above, with L^2 sections of the DeRham complex

$$\mathcal{H}_{SQM} = \Omega_{L^2}^\bullet(X) \quad (12.16)$$

From (12.5) and (12.15) it is clear that the supersymmetry operator may be written as follows:

$$\begin{aligned} \mathbf{Q} &= \oint d\sigma \bar{F}_\mu \Psi^\mu \\ &= \oint d\sigma (-2iG_{\mu\nu} \dot{\phi}^\nu - 2i\partial_\mu W) \Psi^\mu \\ &= -i \oint d\sigma \pi_\mu \Psi^\mu \end{aligned} \quad (12.17)$$

and similarly for \mathbf{Q}^* . Note that the hermitean supersymmetry operators are given by

$$\begin{aligned} \mathbf{Q} &= ie^W d e^{-W} \\ \mathbf{Q}^* &= -ie^{-W} d^* e^W \end{aligned} \quad (12.18)$$

where d and d^* are the exterior derivative on X and its adjoint. (Note that on the wavefunctions $d = \Psi^\mu \frac{\partial}{\partial \phi^\mu} \cdot$.)

Finally we note that these operators satisfy

$$\mathbf{Q}^2 = (\mathbf{Q}^*)^2 = 0 \quad .$$

The Hamiltonian is given by

$$H = \{\mathbf{Q}, \mathbf{Q}^*\}. \quad (12.19)$$

12.3.1. $\text{Tr}(-1)^F$

The motivation for $\text{Tr}(-1)^F$ came from the search for a particle theory model of dynamical supersymmetry breaking. Witten introduced the index $\text{Tr}(-1)^F$ to give a sufficient condition for the presence of supersymmetric ground states. A supersymmetric Hamiltonian satisfies (12.19) and therefore boson/fermion states of nonzero energy are always paired. On the other hand, the supersymmetric ground states, i.e., the zero energy states need not be paired.

Now, small perturbations of the theory may lift $E = 0$ states, but bosonic and fermionic states must always be lifted in pairs. Thus, while the total number of supersymmetric ground states might be difficult to calculate, the difference of the number of bosonic

$E = 0$ states minus the number of fermionic $E = 0$ states is invariant under many perturbations of the theory and might be more accessible to calculation. Thus, for example, it will be a topological invariant of SQM on X , if X is compact. For this reason Witten introduced the index:

$$\mathrm{Tr}_{E=0} (-1)^F \equiv \#[E = 0 \text{ bosons}] - \#[E = 0 \text{ fermions}]. \quad (12.20)$$

Let us examine the supersymmetric, $E = 0$, states in SQM when X is compact and $W = 0$ ²². These are annihilated by both \mathbf{Q} and \mathbf{Q}^* . Since, by (12.53), these operators are related to d and d^* by conjugation with an invertible operator, the supersymmetric states are in 1-1 correspondence with the harmonic forms on X . By Hodge theory we identify the vector space of $E = 0$ states with the DeRham cohomology $H^\bullet(X)$ ²³. Moreover, with our choice of vacuum above, which is sensible for X compact and $W = 0$, form degree is identical to fermion number. So $H^j(X)$ is the space of supersymmetric ground states of fermion number j . The Witten index is therefore the Euler character of X :

$$\begin{aligned} \mathrm{Tr}_{E=0} (-1)^F &= \sum_j (-1)^j \dim H^j(X; R) \\ &= \chi(X). \end{aligned} \quad (12.21)$$

12.3.2. The partition function

We are now in a position to confirm the result (12.14). Using the pairing of nonzero energy states the index may be written as a trace over the entire Hilbert space:

$$\begin{aligned} \mathrm{Tr}_{E=0} (-1)^F &= \mathrm{Tr}_{\mathcal{H}} (-1)^F e^{-\beta H} \\ &= \mathrm{str} e^{-\beta H} \end{aligned} \quad (12.22)$$

where $\mathrm{Re} \beta > 0$ regulates the supertrace. Standard manipulations²⁴ allow us to express the partition function $\mathrm{str} e^{-\beta H}$ of a theory in terms of a path integral with a periodic Euclidean time of period β . Thus the partition function of SQM is just the Euler character of X :

$$\int d\phi \int_{P.B.C.} d\Psi d\bar{\Psi} e^{-I} = \chi(X) \quad (12.23)$$

Note that the partition function is special and topological because only the $E = 0$ states contribute to the trace.

Remark. The parameter β may be identified with the parameter t of the MQ formalism.

²² Quantization with $W \neq 0$ leads to Morse theory. See appendix 4.

²³ When X is noncompact there are infinitely many harmonic forms and we need W to regulate the behavior at infinity to define a good Hodge theory. See appendix 3 below.

²⁴ See J. Fröhlich's contribution to this volume.

12.4. Appendix 1: The two-dimensional supersymmetric nonlinear sigma model

The theories of chapters 12 and 13 are closely related to the 2D supersymmetric nonlinear sigma model. We collect here some basic formulae.

12.4.1. Superfields

The $N = 1, 2$ supersymmetric sigma models ($S\sigma M$) in $d = 2$ are conveniently obtained by dimensional reduction from the $N = 1$ $S\sigma M$ in $d = 4$ [232]. The supersymmetry generators of the four dimensional theory are given by²⁵

$$Q_\alpha = \partial_\alpha - i\sigma_{\alpha\dot{\alpha}}^m \bar{\theta}^{\dot{\alpha}} \partial_m \quad \bar{Q}_{\dot{\alpha}} = -\bar{\partial}_{\dot{\alpha}} + i\sigma_{\alpha\dot{\alpha}}^m \theta^\alpha \partial_m \quad (12.24)$$

where for $\alpha, \dot{\alpha} = +, -$, we have the two Weyl spinors θ^α and $\bar{\theta}_{\dot{\alpha}}$; moreover, $\partial_\alpha = \frac{\partial}{\partial\theta^\alpha}$ and $\bar{\partial}_{\dot{\alpha}} = \frac{\partial}{\partial\bar{\theta}^{\dot{\alpha}}}$. The (future) worldsheet coordinates are given by x^m , $m = 0, \dots, 3$. The covariant superderivatives are

$$D_\alpha = \partial_\alpha + i\sigma_{\alpha\dot{\alpha}}^m \bar{\theta}^{\dot{\alpha}} \partial_m \quad \bar{D}_{\dot{\alpha}} = -\bar{\partial}_{\dot{\alpha}} - i\sigma_{\alpha\dot{\alpha}}^m \theta^\alpha \partial_m. \quad (12.25)$$

Superspace provides an expedient way to formulate supersymmetric field theories. In four dimensions the chiral superfields (satisfying $\bar{D}_{\dot{\alpha}}\Phi = 0$) are given by

$$\Phi^\mu(x, \theta, \bar{\theta}) = \phi^\mu(y) + \theta^\alpha \psi_\alpha^\mu(y) + \theta^\alpha \theta_\alpha F^\mu(y), \quad (12.26)$$

where $y^m = x^m + i\theta^\alpha \sigma_{\alpha\dot{\alpha}}^m \bar{\theta}^{\dot{\alpha}}$.

²⁵ We adopt the conventions of Wess and Bagger [213] with a Minkowskian metric, $\eta_{mn} = \text{diag}(-1, 1, 1, 1)$ and with $\sigma_{\alpha\dot{\alpha}}^m$

$$\begin{aligned} \sigma^0 &= \begin{pmatrix} -1 & 0 \\ 0 & -1 \end{pmatrix} & \sigma^1 &= \begin{pmatrix} 0 & 1 \\ 1 & 0 \end{pmatrix} \\ \sigma^2 &= \begin{pmatrix} 0 & -i \\ i & 0 \end{pmatrix} & \sigma^3 &= \begin{pmatrix} 1 & 0 \\ 0 & -1 \end{pmatrix} \end{aligned}$$

Spinor indices are raised and lowered via

$$\epsilon_{\alpha\beta} = \begin{pmatrix} 0 & -1 \\ 1 & 0 \end{pmatrix} \quad \epsilon^{\alpha\beta} = \begin{pmatrix} 0 & 1 \\ -1 & 0 \end{pmatrix}$$

Moreover,

$$\int d^2\bar{\theta} d^2\theta \bar{\theta}^2 \theta^2 = 1.$$

12.4.2. $N = 2, d = 2$ Supersymmetric Sigma Models: Field Content

We dimensionally reduce by dropping the dependencies on x^1 and x^2 . We also Wick rotate to Euclidean space, by setting $\tau = ix^0$ (and $\sigma = x^3$). Then

$$\begin{aligned} Q_- &= \partial_- - \bar{\theta}^- \bar{\partial} & Q_+ &= \partial_+ - \bar{\theta}^+ \partial \\ \bar{Q}_- &= -\bar{\partial}_- + \theta^- \bar{\partial} & \bar{Q}_+ &= -\bar{\partial}_+ + \theta^+ \partial \end{aligned} \quad (12.27)$$

and

$$\begin{aligned} D_- &= \partial_- + \bar{\theta}^- \bar{\partial} & D_+ &= \partial_+ + \bar{\theta}^+ \partial \\ \bar{D}_- &= -\bar{\partial}_- - \theta^- \bar{\partial} & \bar{D}_+ &= -\bar{\partial}_+ - \theta^+ \partial. \end{aligned} \quad (12.28)$$

where we have defined local complex coordinates $z = \frac{1}{2}(\tau + i\sigma)$ and $\bar{z} = \frac{1}{2}(\tau - i\sigma)$; we have also used the obvious shorthand $\partial = \frac{\partial}{\partial z}$ and $\bar{\partial} = \frac{\partial}{\partial \bar{z}}$.

The dimensional reduction of the superfields (12.26) leads us to consider the chiral $N = 2$ superfields:

$$\Phi(z, \bar{z}, \theta, \bar{\theta}) = \phi(w_1, w_2) + \theta^+ \psi_+(w_1, w_2) + \theta^- \psi_-(w_1, w_2) + \theta^- \theta^+ F(w_1, w_2) \quad (12.29)$$

where $w_1 = z + \theta^+ \bar{\theta}^+$ and $w_2 = \bar{z} + \theta^- \bar{\theta}^-$ satisfy the conditions: $\bar{D}_\pm w_{1,2} = 0$.²⁶ Under $N = 2$ supersymmetry transformations the component fields transform as follows:

$$\begin{aligned} \delta\phi^\mu &= \epsilon^- \psi_-^\mu + \epsilon^+ \psi_+^\mu \\ \delta\psi_+^\mu &= \bar{\epsilon}^+ \partial\phi^\mu + \epsilon^- F^\mu \\ \delta\psi_-^\mu &= \bar{\epsilon}^- \bar{\partial}\phi^\mu - \epsilon^+ F^\mu \\ \delta F^\mu &= \bar{\epsilon}^- \bar{\partial}\psi_+^\mu - \bar{\epsilon}^+ \partial\psi_-^\mu \quad . \end{aligned} \quad (12.30)$$

12.4.3. $N = 1, d = 2$ Supersymmetric Sigma Models

We are also interested in constructing the $N = 1$ $S\sigma M$ in $d = 2$. This is easily obtained from the $N = 2$ $S\sigma M$ in $d = 2$, by imposing the condition that $\bar{\theta}$ is the charge conjugate of θ rather than an independent spinor²⁷. We set

$$\theta^+ = -i\bar{\theta}^+ = \theta \quad \theta^- = -i\bar{\theta}^- = \bar{\theta} \quad (12.31)$$

²⁶ For two dimensional theories, it is also possible to have twisted chiral superfields, i.e. Φ , such that $\bar{D}_+ \Phi = D_- \Phi = 0$.

²⁷ In the conventions that we have adopted, the charge conjugation matrix is given by

$$C = \begin{pmatrix} & -i \\ i & \end{pmatrix}$$

so that $\psi_{\dot{\alpha}}^c = C_{\alpha\dot{\alpha}} \psi^{*\alpha}$ and the self-conjugacy condition is $\begin{pmatrix} \bar{\psi}^- \\ \bar{\psi}^+ \end{pmatrix} = i \begin{pmatrix} \psi^- \\ \psi^+ \end{pmatrix}$.

and

$$\begin{aligned}\bar{Q} &= \bar{\partial}_{\bar{\theta}} - i\bar{\theta}\bar{\partial} & Q &= \partial_{\theta} - i\theta\partial \\ \bar{D} &= \bar{\partial}_{\bar{\theta}} + i\bar{\theta}\bar{\partial} & D &= \partial_{\theta} + i\theta\partial.\end{aligned}\tag{12.32}$$

Note that $Q_- = i\bar{Q}_- = Q$ and $Q_+ = i\bar{Q}_+ = \bar{Q}$ and similarly for \bar{D}_{\pm} . The $N = 1$ superfields are given by

$$\Phi^{\mu}(z, \bar{z}, \theta, \bar{\theta}) = \phi^{\mu}(z, \bar{z}) + \theta\bar{\psi}^{\mu}(z, \bar{z}) + \bar{\theta}\psi^{\mu}(z, \bar{z}) + \bar{\theta}\theta F^{\mu}(z, \bar{z}).\tag{12.33}$$

The component fields transform as follows under the supersymmetry

$$\begin{aligned}\delta\phi^{\mu} &= \epsilon\bar{\psi}^{\mu} + \bar{\epsilon}\psi^{\mu} \\ \delta\bar{\psi}^{\mu} &= i\epsilon\partial\phi^{\mu} - \bar{\epsilon}F^{\mu} \\ \delta\psi^{\mu} &= i\bar{\epsilon}\bar{\partial}\phi^{\mu} + \epsilon F^{\mu} \\ \delta F^{\mu} &= i\epsilon\partial\bar{\psi}^{\mu} - i\bar{\epsilon}\bar{\partial}\psi^{\mu}.\end{aligned}\tag{12.34}$$

The basic action of the $N = 1$ S σ M in $d = 2$ is

$$I = \int d^2z d\bar{\theta}d\theta G_{\mu\nu}(\Phi)\bar{D}\Phi^{\mu}D\Phi^{\nu},\tag{12.35}$$

to which we may add a potential term

$$\Delta I = 2 \int d^2z d\bar{\theta}d\theta W(\Phi),\tag{12.36}$$

where the hermiticity of the action requires that W be a real-valued function of Φ . After integrating out $F^{\mu} = \Gamma_{\lambda\nu}^{\mu}\psi^{\lambda}\bar{\psi}^{\nu} + \partial^{\mu}W$, we get the action in components:

$$\begin{aligned}I + \Delta I &= \int d^2z \left\{ G_{\mu\nu}(\partial\phi^{\mu}\bar{\partial}\phi^{\nu} - i\bar{\psi}^{\mu}D_{\bar{z}}^{(0)}\bar{\psi}^{\nu} - i\psi^{\mu}D_z^{(0)}\psi^{\nu}) + \frac{1}{2}R_{\kappa\lambda\mu\nu}\psi^{\kappa}\psi^{\lambda}\bar{\psi}^{\mu}\bar{\psi}^{\nu} \right. \\ &\quad \left. + 2(\nabla_{\mu}\nabla_{\nu}W)\psi^{\mu}\bar{\psi}^{\nu} + G^{\mu\nu}\partial_{\mu}W\partial_{\nu}W \right\}\end{aligned}\tag{12.37}$$

where $(D_z^{(0)}\psi)^{\mu} = \partial\psi^{\mu} + \Gamma_{\lambda\nu}^{\mu}\partial\phi^{\lambda}\psi^{\nu}$. Later we will need the coupling to a curved world-sheet with metric $h_{\alpha\beta}$. The changes to the action are:

$$\begin{aligned}d^2z &\longrightarrow d^2z\sqrt{h} \\ D_{\bar{z}}^{(0)}\bar{\psi}^{\mu} &\longrightarrow \bar{\partial}\bar{\psi}^{\mu} - \frac{i}{2}\omega_{\bar{z}}\bar{\psi}^{\mu} + \Gamma_{\lambda\nu}^{\mu}\bar{\partial}\phi^{\lambda}\bar{\psi}^{\nu} \\ D_z^{(0)}\psi^{\mu} &\longrightarrow \partial\psi^{\mu} + \frac{i}{2}\omega_z\psi^{\mu} + \Gamma_{\lambda\nu}^{\mu}\partial\phi^{\lambda}\psi^{\nu}\end{aligned}\tag{12.38}$$

where ω is the spin connection.

12.4.4. Canonical Quantization

When discussing canonical quantization we take σ periodic with period L . Canonical quantization leads to

$$\begin{aligned}
[\phi^\mu(\sigma, \tau), \dot{\phi}^\nu(\tilde{\sigma}, \tau)] &= iG^{\mu\nu}(\sigma, \tau)\delta(\sigma - \tilde{\sigma}) \\
\{\psi^\mu(\sigma, \tau), \psi^\nu(\tilde{\sigma}, \tau)\} &= G^{\mu\nu}(\sigma, \tau)\delta(\sigma - \tilde{\sigma}) \\
\{\bar{\psi}^\mu(\sigma, \tau), \bar{\psi}^\nu(\tilde{\sigma}, \tau)\} &= G^{\mu\nu}(\sigma, \tau)\delta(\sigma - \tilde{\sigma}) \\
\{\psi^\mu(\sigma, \tau), \bar{\psi}^\nu(\tilde{\sigma}, \tau)\} &= 0
\end{aligned} \tag{12.39}$$

The hermitean supersymmetry operators are given by

$$\begin{aligned}
Q &= \oint d\sigma \left(iG_{\mu\nu}\psi^\mu\dot{\phi}^\nu - \psi^\mu\Gamma_{\mu\lambda\nu}\psi^\lambda\bar{\psi}^\nu + \psi^\mu\partial_\mu W \right) \\
\bar{Q} &= \oint d\sigma \left(iG_{\mu\nu}\bar{\psi}^\mu\dot{\phi}^\nu + \bar{\psi}^\mu\Gamma_{\mu\lambda\nu}\psi^\lambda\bar{\psi}^\nu - \bar{\psi}^\mu\partial_\mu W \right)
\end{aligned} \tag{12.40}$$

12.4.5. Dimensional Reduction

We further dimensionally reduce to $d = 1$ SQM by dropping all σ dependence and studying only the zero modes of the fields. We introduce

$$\begin{aligned}
\Psi^\mu &= \psi^\mu + i\bar{\psi}^\mu \\
\bar{\Psi}_\mu &= G_{\mu\nu}(\psi^\nu - i\bar{\psi}^\nu) \\
\mathbf{Q} &= Q + i\bar{Q}.
\end{aligned}$$

Under \mathbf{Q} the fields transform as in (12.5). Dimensionally reducing (12.37) we recover the formulae of section 12.1.

12.5. Appendix 2: Index theorems for some elliptic operators

Although somewhat of a digression, SQM yields an elementary proof of the index theorems [9] for various elliptic operators. This very beautiful application of SQM was worked out by L. Alvarez-Gaumé and by D. Friedan and P. Windey [3,86].

We have already seen that SQM may be used to compute the index of the DeRham complex

$$\text{ind } d = \chi(M) = \int d\phi \int_{P.B.C.} d\Psi d\bar{\Psi} e^{-I_{SQM}}$$

The indices of all the other classical elliptic complexes may be computed similarly. As we will have occasion to use several index theorems below, we will briefly sketch the main idea. We refer the interested reader to the literature [3,86] for details.

Given an elliptic complex (E, D) one seeks to construct a SQM model whose supercharge corresponds to D . Then

$$\begin{aligned} \text{ind}(\mathcal{H}, Q) &\stackrel{\text{def}}{=} \sum_F (-1)^F \dim \ker H_F \\ &\parallel \\ \text{ind}(E, D) &\stackrel{\text{def}}{=} \sum_p (-1)^p \dim \ker \Delta_p(E, D) \end{aligned}$$

where $H_F = Q_F Q_{F+1}^* + Q_F^* Q_{F-1}$ is the Hamiltonian on the fermion number F sector of the Hilbert space and Δ_p is the Laplacian on p -forms in the complex (E, D) .

Once one has constructed an appropriate SQM model, $\text{ind}(E, D)$ may be computed by evaluating the partition function

$$\text{ind}(E, D) = \int_{B.C.} e^{-I_{SQM}}$$

where $B.C.$ is schematic for an appropriate set of boundary conditions.

12.5.1. The Index of the Dirac Complex

The index of the Dirac operator is obtained by reducing the supersymmetry to $N = \frac{1}{2}$, by imposing the condition

$$\Psi_+^\mu = \Psi_-^\mu = 2^{-1/2} \tilde{\Psi}^\mu$$

From the Bianchi identity it follows that the curvature term in I disappears, leaving

$$I_{SQM}^{N=\frac{1}{2}} = \int dt \left\{ -\frac{1}{2} G_{\mu\nu} \dot{\phi}^\mu \dot{\phi}^\nu + \frac{1}{2} G_{\mu\nu} \tilde{\Psi}^\mu D_t \tilde{\Psi}^\nu \right\}$$

There is one remaining supersymmetry and the supercharge Q for this model is related to the Dirac operator, $i\mathcal{D}$, on the target space. Evaluating the path integral of this theory (e.g. by expanding about the constant bosonic background) one finds [3]

$$\boxed{\text{ind } i\mathcal{D} = \int_M \hat{A}(M)}$$

(12.41)

where $\hat{A}(M)$ is the A -roof genus

$$\hat{A}(M) = \prod_{a=1}^{\frac{1}{2} \dim M} \frac{\frac{1}{2} x_a}{\sinh \frac{1}{2} x_a} = 1 - \frac{1}{24} p_1(M) + \frac{1}{5760} (7p_1^2 - 4p_2)(M) + \dots \quad (12.42)$$

Here x_a label the eigenvalues of the skew-diagonalized form $\frac{1}{2\pi} R_{ab}$ and $p_i(M)$ are the Pontryagin classes.

12.5.2. The Index of the Twisted Dirac Complex

Taking the tensor product of the Dirac complex with a vector bundle, E , one obtains the twisted Dirac complex, whose index may be computed from the following SQM action[3]

$$I = \int dt \left\{ G_{\mu\nu} \left[\frac{1}{2} \dot{\phi}^\mu \dot{\phi}^\nu - \frac{i}{2} \tilde{\Psi}^\mu D_t \tilde{\Psi}^\nu \right] + i C_i^* \left(\dot{C}_i - A_\mu^a(\phi) \dot{\phi}^\mu T_{ij}^a C_j \right) - \frac{i}{2} \tilde{\Psi}^\mu \tilde{\Psi}^\nu F_{\mu\nu}^a C_i^* T_{ij}^a C_j \right\}$$

where A_μ is the connection on the associated bundle (viewed here as an external gauge field) and the C_i form a Clifford algebra in the representation of G generated by T_{ij}^a . Evaluating the partition function, one finds

$$\boxed{\text{ind } i\mathcal{D}_A = \int_M \text{ch}(F) \wedge \hat{A}(M)}$$
(12.43)

where $\text{ch}(F)$ is the Chern character

$$\text{ch}(F) = \text{Tr} \exp \frac{i}{2\pi} F = \text{rank } E + c_1(F) + \frac{1}{2}(c_1^2 - 2c_2)(F) + \dots$$
(12.44)

and the $c_i(F)$ are the Chern classes of F .

12.5.3. The Index of the Dolbeault Complex

If the target space admits a Kähler structure, then the σ -model actually has two independent supersymmetries. The exterior algebra refines to

$$\Lambda^\bullet(M) = \bigoplus_{p,q=0}^{\dim_{\mathbb{C}} M} \Lambda^{p,q}(M).$$
(12.45)

If we restrict the computation of the SQM partition function to the anti-holomorphic, $(0, p)$, part of the Hilbert space we find

$$\boxed{\text{ind } \bar{\partial} = \int_M \text{td}(M)}$$
(12.46)

where $\text{td}(M)$ is the *Todd class*

$$\text{td}(M) = \prod_{a=1}^{\frac{1}{2}\dim M} \frac{x_a}{1 - e^{-x_a}} = 1 + \frac{1}{2}c_1(M) + \frac{1}{12}(c_1^2 + c_2)(M) + \dots \quad (12.47)$$

As with the Dirac operator we may take the tensor product of the Dolbeault complex with a vector bundle E and compute the index of the twisted complex:

$$\boxed{\text{ind } \bar{\partial}_E = \int_M \text{ch}(E) \wedge \text{td}(M)} \quad (12.48)$$

12.6. Appendix 3: Noncompact X and runaway vacua

We can illustrate one example in which formally Q -exact perturbations of a topological theory in fact change the physical answers. We will take $X = \mathbb{R}$ and $W =$ a polynomial. The supersymmetric groundstates must be annihilated by \mathbf{Q} and \mathbf{Q}^* . From (12.18) it is apparent that they must be a linear combination of

$$e^{W(\phi)} \quad e^{-W(\phi)} d\phi \quad (12.49)$$

which have fermion number ($F =$ form degree) 0 and 1, respectively. These states have norms:

$$\begin{aligned} \|e^{W(\phi)}\|^2 &= \int_{\mathbb{R}} d\phi e^{2W} \\ \|e^{-W(\phi)} d\phi\|^2 &= \int_{\mathbb{R}} d\phi e^{-2W} \end{aligned} \quad (12.50)$$

which must be finite in order for the state to be admissible. It follows that $\text{Tr}(-1)^F$ is given by

$$\text{Tr}(-1)^F = \begin{cases} -1 & \text{for } W = a\phi^{2n} + \dots \quad \text{and } a > 0 \\ 0 & \text{for } W = a\phi^{2n+1} + \dots \\ +1 & \text{for } W = a\phi^{2n} + \dots \quad \text{and } a < 0 \end{cases} \quad (12.51)$$

To see how a BRST exact perturbation can change a physical answer we first reinterpret the system. Represent the Clifford algebra by 2×2 matrices so that

$$\begin{aligned} \mathbf{Q} &= \begin{pmatrix} 0 & 0 \\ 1 & 0 \end{pmatrix} \left(\frac{d}{d\phi} - W' \right) \\ \mathbf{Q}^* &= - \begin{pmatrix} 0 & 1 \\ 0 & 0 \end{pmatrix} \left(\frac{d}{d\phi} + W' \right) \end{aligned} \quad (12.52)$$

Computing the Hamiltonian, $H = \{Q, Q^*\}$, one sees that we are discussing a theory of electrons in a magnetic field with potential $V = (W')^2$.²⁸ If V has an even number of zeroes SUSY is broken (nonperturbatively), otherwise it is not.

Suppose now that $W_0 = \phi^{2n} + \dots$ and that we add a “small” perturbation $\Delta W = \epsilon \phi^{2n+1}$. By (12.6) this leads to a BRST exact change in the action. On the other hand, by the above exact results we see that it changes the value of Z ! The reason for the failure of BRST decoupling is that ΔW brings in new fixed points “from infinity.” That is, as $\epsilon \rightarrow 0$ the extra zero of V runs out to infinity.

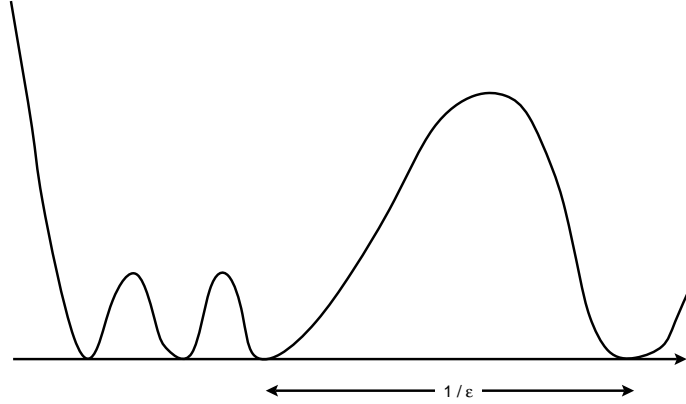

Fig. 30: Vacuum state receding to infinity for $\epsilon \rightarrow 0$.

12.7. Appendix 4: Canonical quantization with $W \neq 0$: Morse theory

In a classic paper [217] Witten reformulated Morse theory using ideas from supersymmetry. Let us take X to be compact and introduce a scale $W \rightarrow -tW$ so that the supersymmetry operators become:

$$Q_t = ie^{-tW} d e^{tW} \quad Q_t^* = -ie^{tW} d^* e^{-tW} \quad (12.53)$$

We will search for SUSY groundstates. Since Q_t is related to d by conjugation with an invertible operator there is a 1-1 correspondence between such states and harmonic forms.

The Hamiltonian of the theory is

$$H_t = \{Q_t, Q_t^*\} = \{d, d^*\} + t^2(\nabla W)^2 + t \frac{D^2 W}{D\phi^\mu D\phi^\nu} [\psi^\mu, \bar{\psi}^\nu] \quad (12.54)$$

²⁸ This representation affords a connection to the theory of Landau levels as discussed in J. Fröhlich’s contribution to this volume.

where the last term involves a *commutator* of the Fermi fields.

Let us look for susy (i.e. $E = 0$) ground states at large t . Because of the potential term these must have their wavefunctions localized near the critical points P of W , i.e. $\nabla W(P) = 0$. Near such a critical point we can choose coordinates which diagonalize the Hessian and write

$$W = W(P) + \frac{1}{2} \sum_{\mu} \lambda_{\mu} (\phi^{\mu})^2 + \mathcal{O}(\phi^3).$$

We will assume all critical points are nondegenerate. This means that $\lambda_{\mu} \neq 0$ for all $\mu = 1, \dots, \dim X$. The number of negative directions is called the Morse index of W at P and is denoted:

$$\lambda(P, W) \equiv \#\{\lambda_{\mu} < 0\}. \quad (12.55)$$

For $t \rightarrow \infty$ the wavefunctions will be exponentially damped away from the critical points. Therefore, we can find approximate ground states by considering the Hamiltonian

$$\bar{H}_t = \sum_{\mu} \left\{ \left[-\frac{\partial^2}{\partial \phi^{\mu 2}} + t^2 \lambda_{\mu}^2 (\phi^{\mu})^2 \right] + \left[t \lambda_{\mu} [\psi^{\mu}, \bar{\psi}^{\mu}] \right] \right\}. \quad (12.56)$$

The operators in square brackets all commute and may be simultaneously diagonalized to give the approximate spectrum:

$$t \sum_{\mu} \left\{ |\lambda_{\mu}| (1 + 2N_{\mu}) + \lambda_{\mu} n_{\mu} \right\}, \quad (12.57)$$

where $N_{\mu} \in \{0, 1, 2, \dots\}$ labels the occupation number of the μ^{th} harmonic oscillator and $n_{\mu} = +1$ if $\psi^{\mu}(P)$ is occupied and -1 if not. As $t \rightarrow \infty$ the only way to get an $E = 0$ state is to take: $N_{\mu} = 0, n_{\mu} = +1$ for $\lambda_{\mu} < 0$ and $N_{\mu} = 0, n_{\mu} = -1$ for $\lambda_{\mu} > 0$. The fermion number of the ground state at P can be taken to be $F(P) = \sum_{\mu=1}^{\dim X} \frac{1}{2} (n_{\mu} + 1)$. Thus:

Each critical point contributes one approximate ground state and it has fermion number j (is a j -form) if $\lambda(P, W) = j$.

Thus M_j , the number of critical points of Morse index j is the number of approximate ground states of fermion number j . In general there are strictly more approximate groundstates than true groundstates. This is the statement of the weak Morse inequalities:

$$M_j \geq b_j.$$

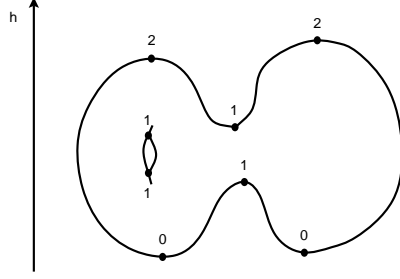

Fig. 31: Bumpy torus with Morse indices of the various critical points

Example: Consider W to be the height function in the torus of fig. 31. Evidently:

$$M_2 = 2 \quad M_1 = 4 \quad M_0 = 2$$

and we have clearly overcounted groundstates, because we know that the true counting is given by DeRham cohomology:

$$b_2 = 1 \quad b_1 = 2 \quad b_0 = 1$$

The degeneracy of approximate $E = 0$ states is lifted by instantons - or tunneling solutions - between the approximate groundstates. Indeed let

$$C^j = \{ | P; \text{approx} \rangle | \lambda(P, W) = j \}$$

Then the degeneracy will be lifted if an instanton solution gives nonzero matrix elements to the supersymmetry operator

$$\langle P_1 | Q_t | P_2 \rangle \tag{12.58}$$

this matrix element being zero to all orders in perturbation theory. In the one-instanton approximation (12.58) is given by a sum over instanton solutions:

$$\langle P_1 | Q_t | P_2 \rangle = \sum_{\Gamma} \pm 1 \tag{12.59}$$

where Γ runs over solutions to

$$\begin{aligned} s^\mu &= \frac{d\phi^\mu}{dt} + G^{\mu\nu} \partial_\nu W = 0 \\ \phi(t = -\infty) &= P_1 \quad \phi(t = +\infty) = P_2 \end{aligned} \tag{12.60}$$

and the sign is determined by considerations of orientations (see [217]).

By supersymmetry $Q_t^2 = 0$ and thus Q_t defines a differential on the chain complex (C^j, Q_t) . Except in extraordinarily symmetric situations²⁹ one-instanton effects will lift the perturbative degeneracy. Mathematically this means that the cohomology of the complex (C^j, Q_t) coincides with the DeRham cohomology:

$$H^\bullet(E^*, Q_t) = H_d^\bullet(X)$$

This last statement is easily seen to be equivalent to the strong Morse inequalities

$$\sum t^j M_j - \sum t^j b_j = (1+t)Q(t)$$

where $Q(t)$ is a polynomial with positive coefficients.

This formulation of Morse theory was generalized by A. Floer in two ways known as symplectic Floer homology and 3-manifold Floer homology. Each of these Floer homology theories plays a role in the canonical formulation of TFT's.

13. Topological sigma models

We will approach the subject of topological sigma models[219] from the Mathai-Quillen point of view, generalizing the discussion of SQM in the previous section.

13.1. Fields and Equations.

We begin with the data:

1. X (the “target space”) is an almost Kähler manifold. This is a symplectic manifold (X, ω) with symplectic form ω together with an almost complex structure, $J \in \text{End}(TX)$ with $J^2 = -1$ such that $G_{\mu\nu} = \omega_{\mu\lambda} J_\nu^\lambda$, i.e., $\omega(J(\cdot), \cdot) = G(\cdot, \cdot)$ is a positive definite metric. The theory simplifies considerably if J is an integrable complex structure so that X is Kähler. We will make this choice, indicating how the theory generalizes at appropriate points.
2. Σ is a 2d surface, with metric h that induces a complex structure, ϵ .

Then in the fields-equations-symmetries paradigm, we have:

²⁹ For example, J. Zinn-Justin suggests three wells symmetric about $\phi = 0$.

- The *fields* will be the space of maps

$$\text{MAP}(\Sigma, X) = \{f \in \mathcal{C}^\infty(\Sigma, X)\}$$

- The *equations* will be the Gromov equations for (pseudo-) holomorphic maps. As we have seen in section 5.5, (equation (5.10)) $f \in \text{MAP}(\Sigma, X)$ is holomorphic iff

$$s(f) \equiv df + Jdf\epsilon = 0 \tag{13.1}$$

with J the (fixed) complex structure of X and ϵ the (fixed) complex structure of Σ . We will denote by $\mathcal{H}(\Sigma, X)$ the space of holomorphic maps from Σ to X .

- The *symmetries* in this example are trivial.

Remark:

The relationship between $\text{MAP}(\Sigma, X)$ and $\mathcal{H}(\Sigma, X)$ is quite analogous to the relationship between the moduli space of (anti-) self-dual connections and the space \mathcal{A}/\mathcal{G} in Yang-Mills theory. Much of the fundamental information about $\text{MAP}(\Sigma, X)$ is already captured by $\mathcal{H}(\Sigma, X)$. In fact, it has been established that the inclusion $\mathcal{H}(\Sigma, X) \xrightarrow{i} \text{MAP}(\Sigma, X)$ induces isomorphisms in homology (and in certain cases also homotopy) groups. For the degree k components of these two spaces, one finds $H_i(\mathcal{H}_k(\Sigma, X)) \cong H_i(\text{MAP}_k(\Sigma, X))$, for $i < N_k$, where N_k is an integer growing linearly with k . These results have been established for Σ an arbitrary Riemann surface and X an arbitrary flag manifold [192,122,101,43,110].

13.2. Differential Forms on $\text{MAP}(\Sigma, X)$

Just as in the example of SQM, we shall study differential geometry on the infinite dimensional space, $\text{MAP}(\Sigma, X)$. In complete analogy to LX we have the natural isomorphism:

$$T_f(\text{MAP}(\Sigma, X)) \cong \Gamma(f^*(TX)) \tag{13.2}$$

Consider formally the DeRham complex, $\Omega^\bullet(\text{MAP}(\Sigma, X))$, as a continuous tensor product of DeRham complexes on the target space X :

$$\Omega^\bullet(\text{MAP}(\Sigma, X)) = \otimes_{\sigma \in \Sigma} \Omega^\bullet(X)_\sigma \tag{13.3}$$

Formally we may think of $f^\mu(\sigma)$ as local coordinates in $\text{MAP}(\Sigma, X)$, and $\tilde{d}f^\mu(\sigma)$ as a basis of one-forms, where \tilde{d} is the exterior derivative on $\text{MAP}(\Sigma, X)$. Under the basic tautology (11.32) we identify $\mathcal{C}^\infty(\widehat{\text{MAP}}(\Sigma, X))$ with forms $\Omega^*(\text{MAP}(\Sigma, X))$ using:

$$\tilde{d}f^\mu(\sigma) \leftrightarrow \chi^\mu(\sigma) \tag{13.4}$$

13.3. Vector Bundle

To apply the MQ formalism we will regard (13.1) as the equation for the vanishing of a section of a vector bundle. Given a map, f , we may form the bundle over Σ , whose fiber at $\sigma \in \Sigma$ is just

$$\left[T^*\Sigma \otimes f^*(TX) \right]_{\sigma} = T^*\Sigma \otimes T_{f(\sigma)}X \cong \text{Hom}(T_{\sigma}\Sigma, T_{f(\sigma)}X)$$

Sections of this bundle form the fibre of a bundle $\mathcal{W} \rightarrow \text{MAP}(\Sigma, X)$. Note that $s(f)$ satisfies the “self-duality” constraint:

$$Js(f)\epsilon = s(f)$$

whether f is holomorphic or not. Hence it is natural³⁰ to consider \mathcal{V} to be the subbundle of \mathcal{W} whose fibre over f is given by:

$$\mathcal{V}_f := \Gamma[T^*(\Sigma_W) \otimes f^*(TX)]^+ \quad (13.5)$$

where the superscript “+” indicates the “self-duality” constraint, i.e.

$$x \in \mathcal{V}_f \iff Jx\epsilon = x \quad (13.6)$$

The antighosts ρ_{μ}^{α} used in the integral construction of the MQ form will live in the dual bundle \mathcal{V}^* . Using the metrics on Σ and X we can write a natural metric on \mathcal{V}^* :

$$(\rho_{(1)}, \rho_{(2)})_{\mathcal{V}_f^*} = \int_{\Sigma} d^2\sigma \sqrt{h} h_{\alpha\beta} G^{\mu\nu}(f(\sigma)) \rho_{(1)\mu}^{\alpha} \rho_{(2)\nu}^{\beta}, \quad (13.7)$$

These formulae simplify in local complex coordinates. We take these to be z, \bar{z} on the worldsheet and i, \bar{i} on the target space. In terms of these the constraint (13.6) reads

$$\rho_i^z = \rho_{\bar{i}}^{\bar{z}} = 0$$

13.4. Choice of connection

In order to write a MQ form whose pullback by s is the Poincaré dual to $\mathcal{H}(\Sigma, X)$ in $\text{MAP}(\Sigma, X)$, we need to choose a connection on \mathcal{V} . We can motivate this connection using

³⁰ In fact, we will see below that it is necessary to make this restriction.

the remarks in section 11.10.3. Recall that, in the MQ formalism, given a connection ∇ on $E = \mathcal{V}$ and a section, s , we form the linear operator

$$\nabla s : T \text{ MAP}(\Sigma, X) \rightarrow \mathcal{V}$$

which determines the fermion bilinear terms in the action. Over the zeroes of s , $\mathcal{Z}(s)$, we have (from section 11.10.3):

$$\ker(\nabla(s))|_{\mathcal{Z}(s)} \cong T\mathcal{Z}(s)$$

In the present case we have chosen $s(f)$, so that $\mathcal{Z}(s)$ is the space of holomorphic maps. We therefore examine the tangent space to the space of holomorphic maps. In the case where X is complex, this tangent space is defined by the equation [93,219]:

$$D\delta f + JD\delta f\epsilon = 0 \quad (13.8)$$

where D is the pulled-back connection

$$(D_\alpha \delta f)^\mu(\sigma) = \partial_\alpha \delta f^\mu + \Gamma_{\kappa\lambda}^\mu \partial_\alpha f^\kappa \delta f^\lambda \quad (13.9)$$

and $\Gamma_{\nu\lambda}^\mu$ is the Christoffel connection of the target Kähler metric. If we consider the case of an almost complex structure, then there is a third term in the equation involving ∇J . An important point to note is that $(D_\alpha \delta f)^\mu$ does *not* satisfy the self-duality constraint.

Exercise. *Variation of the Gromov equation*

Derive (13.8) and (13.9).

It is important to note that the Gromov equation is non-linear in f . We can make this clear by explicitly indicating that J is evaluated at $f(\sigma)$:

$$df(\sigma) + J[f(\sigma)]df(\sigma)\epsilon(\sigma) = 0 \quad (13.10)$$

Now consider a one parameter family of holomorphic maps

$$F: \Sigma \times I \rightarrow X$$

$$F(\sigma; t) \mapsto f_t(\sigma)$$

with $f_0(\sigma) = f(\sigma)$. This family must also satisfy the Gromov equation

$$df_t(\sigma) + J[f_t(\sigma)]df_t(\sigma)\epsilon(\sigma) = 0 \quad \forall \sigma \in \Sigma \text{ and } \forall t \in I$$

Now take the derivative with respect to t and evaluate at $t = 0$. We suppress worldsheet indices where they are obvious.

$$\left[df_t^\mu(\sigma) + \partial_\kappa J_{\nu}^\mu[f_t(\sigma)]\dot{f}_t^\kappa(\sigma)df_t^\nu(\sigma)\epsilon(\sigma) + J_{\nu}^\mu[f_t(\sigma)]d\dot{f}_t^\nu(\sigma)\epsilon(\sigma) \right]_{t=0} = 0$$

Now consider the covariant derivative of J

$$\nabla_\kappa J_{\nu}^\mu = \partial_\kappa J_{\nu}^\mu + \Gamma_{\kappa\lambda}^\mu J_{\nu}^\lambda - \Gamma_{\kappa\nu}^\lambda J_{\lambda}^\mu$$

Then we may write (setting $\delta f^\mu = \dot{f}_t^\mu|_{t=0}$)

$$\partial_\kappa J_{\nu}^\mu \delta f^\kappa df^\nu \epsilon = -\Gamma_{\kappa\lambda}^\mu J_{\nu}^\lambda \delta f^\kappa df^\nu \epsilon + \Gamma_{\kappa\nu}^\lambda J_{\lambda}^\mu \delta f^\kappa df^\nu \epsilon + \nabla_\kappa J_{\nu}^\mu \delta f^\kappa df^\nu \epsilon$$

Now since $f_t(\sigma)$ is, by fiat, a family of holomorphic maps, $df_t^\mu \epsilon = J_{\nu}^\mu df_t^\nu \epsilon$, for all t , so that

$$\partial_\kappa J_{\nu}^\mu \delta f^\kappa df^\nu \epsilon = \Gamma_{\kappa\nu}^\lambda J_{\lambda}^\mu \delta f^\kappa df^\nu \epsilon - \Gamma_{\kappa\lambda}^\mu \delta f^\kappa df^\lambda \epsilon + \nabla_\kappa J_{\nu}^\mu \delta f^\kappa df^\nu \epsilon$$

From this deduce (13.8) and (13.9). Determine the equation for the tangent space in the case when X is not complex.

Equation (13.8) suggests that we should define the 1-form on $\text{MAP}(\Sigma, X)$:

$$\mathbb{D} = D\chi + JD\chi\epsilon$$

where we identify $\chi^\mu(\sigma)$ with one-forms as in (13.4). A convenient choice of connection will be one for which this is ∇s . Let $z_\alpha^\mu[f]$ be a local section of $\mathcal{V} \rightarrow \text{MAP}(\Sigma, X)$ then define:

$$\begin{aligned} \nabla z_\alpha^\mu &= \tilde{d}z_\alpha^\mu - \Gamma_{\kappa\lambda}^\mu z_\alpha^\kappa \tilde{d}f^\lambda \\ &= \int d^2\sigma \sqrt{h} \left(\frac{\delta z_\alpha^\mu}{\delta f^\kappa(\sigma)} \tilde{d}f^\kappa(\sigma) - \Gamma_{\kappa\lambda}^\mu[f(\sigma)] z_\alpha^\kappa \tilde{d}f^\kappa(\sigma) \right) \end{aligned} \quad (13.11)$$

In the first line we use condensed notation. \tilde{d} is the exterior derivative on $\text{MAP}(\Sigma, X)$. One may easily check that ∇s satisfies the self-duality constraint. Thus we will adopt this connection.

Exercise. Connection

Derive the relation:

$$\nabla s = \mathbb{D} \quad . \quad (13.12)$$

Remember that J depends on f so the functional derivative acts on it. Use the fact that the complex structure is integrable. When that is not the case, there is an extra term corresponding to the extra term in the equation for the tangent space.

Remark: The physical reason for imposing the self-duality constraint on the fields ρ_μ^α is that the anti-dual components do not enter into the action following from the gauge fermion below. Mathematically the operator ∇s fails to be Fredholm without this constraint.

13.5. BRST Complex

The final ingredient we need in order to apply the formulae of chapter 11 is the differential Q . Having chosen the connection, we have effectively applied the Chern-Weil homomorphism, so the BRST complex will be made of the basic differential forms, $\Omega(\mathcal{V}^*)$, on the total space \mathcal{V}^* . As usual we identify this with a superspace of functions $\widehat{\mathcal{F}}(\mathcal{V}^*)$. The coordinates on the base are $f^\mu(\sigma)$ and $\chi^\mu(\sigma)$, as above. The superspace coordinates on the fiber $\widehat{\mathcal{F}}(\mathcal{V}_f^*)$ will be even coordinates π_μ^α and odd coordinates $\rho_\mu^\alpha \in \Pi\mathcal{V}_f^*$, the ‘‘anti-ghosts.’’ Note that because of the self-duality constraint $\rho_i^z = \rho_{\bar{i}}^{\bar{z}} = \pi_i^z = \pi_{\bar{i}}^{\bar{z}} = 0$. The grading on the complex is given by the ghost number. χ has ghost number 1 and ρ has ghost number -1 ; the bosonic fields f and π both have ghost number zero.

The BRST differential is given by $Q = \tilde{d} \otimes 1 + 1 \otimes \delta$, where δ is (implicitly) defined by:

$$\begin{aligned} Qf^\mu &= \chi^\mu & Q\chi^\mu &= 0 \\ Q\rho_\mu^\alpha &= \pi_\mu^\alpha & Q\pi_\mu^\alpha &= 0. \end{aligned} \quad (13.13)$$

Put more succinctly, Q is the DeRham exterior derivative on the total space of $\Pi\mathcal{V}^*$.

13.6. Gauge Fermion and Action

According to sections 11.5, 11.8, we should take the gauge fermion:

$$\begin{aligned}\Psi_t &= i\langle \rho, s \rangle - t(\rho, \theta\rho)_{V^*} + t(\rho, \pi)_{V^*} \\ &= \int d^2\sigma \sqrt{h} \left\{ \rho_\mu^\alpha \left(i s_\alpha^\mu - t \Gamma_{\kappa\lambda}^\mu G^{\kappa\kappa'} h_{\alpha\alpha'} \rho_{\kappa'}^{\alpha'} \chi^\lambda + t G^{\mu\mu'} h_{\alpha\alpha'} \pi_{\mu'}^{\alpha'} \right) \right\}\end{aligned}\quad (13.14)$$

where we have used the metric (13.7) and the connection (13.11) to raise and lower indices on ρ and π . This formulation of the gauge fermion was first obtained in [24]. There are modifications to this action involving ∇J in the case where X is not Kähler.

Acting with Q and integrating out the Lagrange multipliers, $\pi_\mu^\alpha = -\frac{i}{2t} G_{\mu\mu'} h^{\alpha\alpha'} s_{\alpha'}^{\mu'} - \rho_{\kappa}^{\alpha} \Gamma_{\mu\lambda}^{\kappa} \chi^\lambda$, we obtain the action:

$$\begin{aligned}I_{t\sigma} &= Q(\Psi_t) \\ &= \int d^2\sigma \sqrt{h} \left\{ \frac{1}{4t} G_{\mu\mu'} h^{\alpha\alpha'} s_\alpha^\mu s_{\alpha'}^{\mu'} - i \rho_\mu^\alpha (D\chi)_\alpha^\mu \right. \\ &\quad \left. - t \rho_\mu^\alpha R_{\nu\rho\sigma}^\mu \chi^\rho \chi^\sigma G^{\nu\nu'} h_{\alpha\alpha'} \rho_{\nu'}^{\alpha'} \right\}.\end{aligned}\quad (13.15)$$

Passing to local complex coordinates on the target and the worldsheet we may write this as:

$$\begin{aligned}\int d^2z \left(\frac{2}{t} G_{i\bar{j}} \partial_{\bar{z}} f^i \partial_z f^{\bar{j}} - i h_{z\bar{z}} \rho_i^{\bar{z}} D_{\bar{z}} \chi^i - i h_{z\bar{z}} \rho_{\bar{i}}^z D_z \chi^{\bar{i}} \right. \\ \left. - 4t G^{j\bar{j}} \rho_i^{\bar{z}} R^i_{j\bar{k}l} \chi^k \chi^{\bar{l}} \rho_{\bar{j}}^z (h_{z\bar{z}})^2 \right).\end{aligned}\quad (13.16)$$

13.7. Observables

Observables are most elegantly constructed using the ‘‘universal map’’. When restricted to the moduli space of holomorphic maps this gives the universal instanton [219]. A very similar construction will appear below in constructing the observables in topological gauge theory .

Given any point $P \in \Sigma$ there is a canonical map $\Phi_P : \text{MAP}(\Sigma, X) \rightarrow X$ given by evaluation at P . These maps fit together to give the ‘‘universal map’’

$$\begin{aligned}\Phi: \Sigma \times \text{MAP}(\Sigma, X) &\longrightarrow X \\ \Phi(P, f) &\longmapsto f(P)\end{aligned}\quad (13.17)$$

Thus, if $A \in \Omega^k(X)$ is a differential form on the target then

$$\Phi_P^*(A) \in \Omega^k(\text{MAP}(\Sigma, X))\quad (13.18)$$

is a form on $\text{MAP}(\Sigma, X)$. Explicitly:

$$\widehat{\mathcal{O}}_A^{(0)}(P) = \widehat{\Phi}_P^*(A) = A_{i_1 \dots i_k}(\phi(P)) \chi^{i_1}(P) \cdots \chi^{i_k}(P) \quad (13.19)$$

Inspection of (13.13) shows that Q acts as

$$\{Q, \widehat{\mathcal{O}}_A^{(0)}\} = \widehat{\mathcal{O}}_{dA}^{(0)} \quad (13.20)$$

In particular we learn that we have explicit representatives of the Q -cohomology in terms of the cohomology of the target for each $A \in H^\bullet(X)$ and $P \in \Sigma$.

To go further we must use the ‘‘descent equations.’’ If we pull back $A \in H^\bullet(X)$ by the universal map (13.17), then we have a closed form on $\Sigma \times \text{MAP}(\Sigma, X)$. Therefore, splitting the exterior derivative into $d + Q$, with d the exterior derivative on Σ we have

$$(d + Q)\widehat{\Phi}^*(A) = 0 \quad (13.21)$$

Now $H^\bullet(\Sigma \times \text{MAP}(\Sigma, X))$ is bigraded by the degrees on Σ and $\text{MAP}(\Sigma, X)$, so we may write:

$$\widehat{\Phi}^*(A) = \widehat{\mathcal{O}}_A^{(0)} + \widehat{\mathcal{O}}_A^{(1)} + \widehat{\mathcal{O}}_A^{(2)} \quad (13.22)$$

where the upper index refers to form degree in the Σ direction. Taking into account the grading of d and Q the statement (13.21) simply becomes the famous descent equations

$$\begin{aligned} 0 &= \{Q, \widehat{\mathcal{O}}_A^{(0)}\} \\ d\widehat{\mathcal{O}}_A^{(0)} &= -\{Q, \widehat{\mathcal{O}}_A^{(1)}\} \\ d\widehat{\mathcal{O}}_A^{(1)} &= -\{Q, \widehat{\mathcal{O}}_A^{(2)}\} \\ d\widehat{\mathcal{O}}_A^{(2)} &= 0 \end{aligned} \quad (13.23)$$

There are two important consequences of these equations. First, it might appear that we have infinitely many BRST observables (one for each P) but this is not the case. The second descent equation shows that

$$\widehat{\mathcal{O}}_A^{(0)}(P') - \widehat{\mathcal{O}}_A^{(0)}(P) = -\{Q, \int_P^{P'} \widehat{\mathcal{O}}^{(1)}\}$$

so the class does not depend on P . Thus, the vector space of BRST classes $\widehat{\mathcal{O}}_A^{(0)}$ is isomorphic to the DeRham cohomology of X . Second, if $\gamma \in H_k(\Sigma)$ is a homology cycle, then we may form the BRST invariant observables:

$$\widehat{W}(A, \gamma) \equiv \int_{\gamma} \widehat{\mathcal{O}}_A^{(k)} = \int_{\gamma} \widehat{\Phi}^*(A) \quad (13.24)$$

where the hat indicates translation to superspace. BRST invariance is proven using the descent equations (13.23).

Remark: In general these are not the only BRST classes in the model. For example[61,108] one can form “homotopy observables” when X is not simply connected.

13.8. Correlation Functions

We now want to study the correlation functions

$$\langle \prod_i \widehat{W}(A_i, \gamma_i) \rangle$$

13.8.1. Localization on moduli space

Since the action is given by the MQ formula, we know that we will localize to $\mathcal{Z}(s) = \mathcal{H}(\Sigma, X)$. Let us apply the discussion of section 11.10.3 to the present model. The operator ∇s defined above in (13.11) is, as we have seen, $\mathbb{D} : T_f \mathcal{M} \rightarrow \mathcal{V}_f$. The sequence (11.49) becomes the sequence:

$$0 \rightarrow \text{Im}(\mathbb{D}) \rightarrow \mathcal{V} \rightarrow \text{cok}(\mathbb{D}) \rightarrow 0$$

The equation (11.50) becomes in this case [8]:

$$\begin{aligned} \int_{\text{MAP}(\widehat{\Sigma}, X)} df d\chi \widehat{\mathcal{O}} \int_{\Pi \mathcal{V}_f^*} d\rho e^{-I_t \sigma} &= \int_{\text{MAP}(\Sigma, X)} \mathcal{O} s^*(\Phi(\mathcal{V}, \nabla)) \\ &= \int_{\mathcal{Z}(s)} i^*(\mathcal{O}) \chi(\text{cok}(\mathbb{D})) \end{aligned} \quad (13.25)$$

where the BRST observables, $\widehat{\mathcal{O}} = \widehat{W}(A, \gamma)$ of section 13.7 correspond to differential forms, \mathcal{O} on $\text{MAP}(\Sigma, X)$, and hence $i^*(\mathcal{O})$ are differential forms on $\mathcal{H}(\Sigma, X) = \mathcal{Z}(s)$, where $i: \mathcal{Z}(s) \hookrightarrow \text{MAP}(\Sigma, X)$ is the inclusion map. We have used the fact that (at least formally)

$$s^*(\Phi(\mathcal{V}, \nabla)) = \int_{\Pi \mathcal{V}_f^*} d\rho e^{-I_t s} \quad (13.26)$$

represents the Euler class of $\chi(\mathcal{V} \rightarrow \text{MAP}(\Sigma, X))$.

Clearly, to get a nonzero integral the form \mathcal{O} must have degree given by

$$\text{ind } \mathbb{D} = \dim \ker \mathbb{D} - \dim \text{cok } \mathbb{D}$$

In physical terms, $\widehat{\mathcal{O}}$ must have ghost number appropriate to the anomaly in the ghost number current.

13.8.2. Zeromodes and the Index theorem

Let us now study the kernel and cokernel of \mathbb{D} more closely. The χ zeromodes span the kernel of \mathbb{D} . The ρ zero-modes are in the bundle $\text{cok } \mathbb{D} \rightarrow \mathcal{Z}(s)$. The operator is a direct sum of holomorphic and antiholomorphic operators. The operator $\mathbb{D}_{\bar{z}} = D_{\bar{z}}$ appearing in (13.16) is the twisted Dolbeault operator $\bar{\partial}_{f^*(TX)}$ discussed in section 12.5 above. Thus the χ^i zeromodes span $H_{\bar{\partial}}^0(\Sigma; f^*T^{1,0}X)$ while the $\rho_{\bar{z}}^i$ zeromodes span $H_{\bar{\partial}}^{0,1}(\Sigma; f^*T^{1,0}X)$.

From the Hirzebruch-Riemann-Roch theorem [105], (cf (12.48) in section 12.5) we have

$$\begin{aligned} \text{ind}_{\mathbb{C}} D_{\bar{z}} &= \#\chi \text{ zero modes} - \#\rho \text{ zero modes} \\ &= \int_{\Sigma_{\mathbb{W}}} (1 + \frac{1}{2}c_1(T^{(1,0)}\Sigma))(\dim_{\mathbb{C}}X + f^*(c_1(T^{(1,0)}X))) \\ &= (1 - h)\dim_{\mathbb{C}}X + \int_{\Sigma_{\mathbb{W}}} f^*(c_1(T^{(1,0)}X)). \end{aligned} \tag{13.27}$$

In order to find the number of χ and ρ zeromodes separately we need an independent argument, typically a vanishing theorem on some cohomology group.

13.8.3. Reduction to Enumerative Geometry

Let us return to (13.25). In terms of the universal map (13.17) we define $\omega(A, \gamma) = \iota^* \int_{\gamma} \Phi^*(A) \in H^{\bullet}(\mathcal{Z}(s))$. The correlation functions are intersection numbers in the moduli space $\mathcal{H}(\Sigma, X) = \mathcal{Z}(s)$:

$$\begin{aligned} \langle \prod W(A_i, \gamma_i) \rangle &= \int_{\mathcal{Z}(s)} \omega(A_1, \gamma_1) \wedge \dots \wedge \omega(A_r, \gamma_r) \\ &\quad \wedge \chi(H_{\bar{\partial}}^{1,0}(\Sigma, f^*(T^{0,1}X))) \wedge \chi(H_{\bar{\partial}}^{0,1}(\Sigma, f^*(T^{1,0}X))) \end{aligned} \tag{13.28}$$

The above intersection numbers can be related to classical problems in enumerative geometry from the following construction [219]. Suppose A is Poincaré dual to $H_A \subset X$, then

we may choose a representative A with delta function support on H_A . The corresponding representative of the class $\mathcal{O}_A^{(0)} \in H^\bullet(\text{MAP}(\Sigma, X))$ has support on

$$L(A, P) = \{f \in \mathcal{H}(\Sigma, X) \mid f(P) \in H_A\}$$

We are computing intersection numbers of these cycles. Roughly speaking, we are “counting” numbers of curves in X which pass through specified points (or homology cycles). This is the initial observation behind the famous curve-counting results provided by mirror symmetry [48]. Further discussion of the relation to enumerative geometry can be found in [127,128].

13.9. Quantum Cohomology

In the case of a Kähler target space, X , the space of local operators of the $N = 2$ sigma model admits a $\mathbb{Z} \oplus \mathbb{Z}$ bigrading:

$$\mathcal{O} = \bigoplus_{p,q \in \mathbb{Z}} \mathcal{O}_{p,q}$$

which resembles the Dolbeault cohomology of X in certain respects. Crucial differences are : (i) the degrees of operators range from $-\infty$ to $+\infty$ and (ii) the existence of an anti-unitary involution under which $\mathcal{O}_{p,q} \rightarrow \mathcal{O}_{-p,-q}$ (this is related to the CPT invariance of the physical theory). The classical cohomology corresponds as a vector space to the Q -cohomology classes. There is a natural way, in the context of string theory, to define an associative and distributive operator product of these operators. Under this product, the operator algebra is closed, i.e.

$$\mathcal{O}_i \mathcal{O}_j = C_{ij}^k \mathcal{O}_k + [Q, \cdot]$$

so that it defines a ring structure called the *quantum cohomology ring* [228,206].

The quantum cohomology ring is related to the classical cohomology ring. Its relation to the classical one can be made apparent if we deform the usual sigma model action by a purely topological term³¹ :

$$I_{\text{top}} = t \int_{\Sigma} f^*(\mathbf{K})$$

³¹ If $\dim H^{(1,1)} > 1$, this deformation generalizes in the obvious way. For the sake of simplicity we will consider the case of only one deformation term.

where $\mathbf{K} \in H^{(1,1)}(X)$. Roughly speaking, the role of this term is the following: if $f: \mathbb{P}^1 \rightarrow C$ is a map of degree n into a rigid curve $C \subset X$, then its contribution to the operator product is weighted by $q^n = e^{-nAt}$, where $A = \int_{\mathbb{P}^1} (f^{(1)})^*(\mathbf{K})$ is the contribution from a map of degree 1, $f^{(1)}: \mathbb{P}^1 \rightarrow C$.

We have seen in 13.7 that the observables of topological sigma models, $\mathcal{O}_A^{(0)}$, are isomorphic to the DeRham cohomology of X . For example, consider a collection of observables corresponding to $A_{i_a} \in H^{1,1}(X, \mathbb{R})$. Let $\{H_{A_{i_a}}\}_{a=1,\dots,3}$ be homology classes in X dual to the A_{i_a} . Then a three point function in the deformed theory has the following structure [64,8]:

$$\begin{aligned} \langle \mathcal{O}_{A_{i_1}} \mathcal{O}_{A_{i_2}} \mathcal{O}_{A_{i_3}} \rangle &= \# (H_{A_{a_1}} \cap H_{A_{a_2}} \cap H_{A_{a_3}}) \\ &+ \sum_{\substack{C \subset X \\ C \text{ isolated} \\ \text{rational curve}}} \sum_{f: \mathbb{P}^1 \rightarrow C} \int_{\mathbb{P}^1} f^*(A_{i_1}) \int_{\mathbb{P}^1} f^*(A_{i_2}) \int_{\mathbb{P}^1} f^*(A_{i_3}) e^{-t \int_{\mathbb{P}^1} f^*(\mathbf{K})} \end{aligned} \quad (13.29)$$

Rescaling the Kähler class is equivalent to changing t . In the limit $t \rightarrow \infty$ only the degree zero (constant) holomorphic maps survive and we recover the classical cohomology ring. It is in this sense that the quantum cohomology ring may be considered to be a deformation of the classical one. Quantum cohomology is under intensive investigation by many mathematicians. See, for example, [127].

13.10. Relation to the physical sigma model

The above presentation of the topological sigma model is somewhat idiosyncratic. In this section we review the standard approach to the subject.

13.10.1. Kähler target

Just as the topological sector of SQM can be related to a larger, nontopological theory, the topological sigma model can be related to a larger theory. In this case it is the $N = 2$ supersymmetric sigma model.

One way to define the $N = 2$ model is to consider the sigma model of section 12.4 with a Kähler target. The splitting of the target space coordinates into holomorphic and

antiholomorphic coordinates allows us to define *two* supersymmetries:

$$\begin{aligned}
\delta_1 \phi^i &= \epsilon^- \psi_-^i + \epsilon^+ \psi_+^i \\
\delta_1 \phi^{\bar{i}} &= 0 \\
\delta_1 \psi_-^i &= -\epsilon^+ F^i \\
\delta_1 \psi_-^{\bar{i}} &= -i\epsilon^- \bar{\partial} \phi^{\bar{i}} \\
\delta_1 \psi_+^i &= \epsilon^- F^i \\
\delta_1 \psi_+^{\bar{i}} &= i\epsilon^+ \partial \phi^{\bar{i}} \\
\delta_1 F^i &= 0 \\
\delta_1 F^{\bar{i}} &= -i\epsilon^+ \partial \psi_-^{\bar{i}} - i\epsilon^- \bar{\partial} \psi_+^{\bar{i}}
\end{aligned} \tag{13.30}$$

and

$$\begin{aligned}
\delta_2 \phi^i &= 0 \\
\delta_2 \phi^{\bar{i}} &= -\bar{\epsilon}^- \psi_-^{\bar{i}} - \bar{\epsilon}^+ \psi_+^{\bar{i}} \\
\delta_2 \psi_-^i &= i\bar{\epsilon}^- \bar{\partial} \phi^i \\
\delta_2 \psi_-^{\bar{i}} &= \bar{\epsilon}^+ F^{\bar{i}} \\
\delta_2 \psi_+^i &= -i\bar{\epsilon}^+ \partial \phi^i \\
\delta_2 \psi_+^{\bar{i}} &= -\bar{\epsilon}^- F^{\bar{i}} \\
\delta_2 F^i &= i\bar{\epsilon}^+ \partial \psi_-^i + i\bar{\epsilon}^- \bar{\partial} \psi_+^i \\
\delta_2 F^{\bar{i}} &= 0
\end{aligned} \tag{13.31}$$

13.10.2. Superspace

More fundamentally, we start with $N = 2$ superspace $(z, \bar{z}, \theta^\pm, \bar{\theta}^\pm)$.³² The action is

$$I = \alpha \int d^2 z d^4 \theta K(\Phi^i, \Phi^{\bar{i}}) + \beta \left(\int d^2 z d^2 \theta W(\Phi^i) + \int d^2 z d^2 \bar{\theta} \bar{W}(\Phi^{\bar{i}}) \right) \tag{13.32}$$

The simplest kinds of $N = 2$ superfields are the chiral and anti-chiral ones. The chiral superfields obey $\bar{D}_\alpha \Phi^i = 0$ and $D_\alpha \Phi^{\bar{i}} = 0$. They are most simply expressed as functions of the variables $z + i\theta^+ \bar{\theta}^+$ and $\bar{z} - i\theta^- \bar{\theta}^-$

$$\Phi^i = \phi^i + \theta^+ \psi_+^i + \theta^- \psi_-^i + \theta^+ \theta^- F^i \tag{13.33}$$

³² Our conventions will be those of [232], hence those of Wess-Bagger *except* that we rescale all θ 's by $\sqrt{2}$.

Similarly, the antichiral superfields

$$\Phi^{\bar{i}} = \phi^{\bar{i}} + \bar{\theta}^+ \psi_+^{\bar{i}} + \bar{\theta}^- \psi_-^{\bar{i}} + \bar{\theta}^+ \bar{\theta}^- F^{\bar{i}} \quad (13.34)$$

are functions of $z - i\theta^+ \bar{\theta}^+$, $\bar{z} + i\theta^- \bar{\theta}^-$.

Supersymmetry transformations are generated by

$$\begin{aligned} Q_+ &= \frac{\partial}{\partial \theta^+} - i\bar{\theta}^+ \partial_z \\ Q_- &= \frac{\partial}{\partial \theta^-} + i\bar{\theta}^- \partial_{\bar{z}} \\ \bar{Q}_+ &= -\frac{\partial}{\partial \bar{\theta}^+} + i\theta^+ \partial_z \\ \bar{Q}_- &= -\frac{\partial}{\partial \bar{\theta}^-} - i\theta^- \partial_{\bar{z}} \end{aligned} \quad (13.35)$$

The action becomes (with $W = 0$):

$$\begin{aligned} I = \int_{\Sigma} d^2 z \left(\frac{1}{2} G_{i\bar{i}} (\partial_z \phi^i \partial_{\bar{z}} \phi^{\bar{i}} + \partial_{\bar{z}} \phi^i \partial_z \phi^{\bar{i}} - i\psi_-^{\bar{i}} D_z \psi_-^i - i\psi_+^{\bar{i}} D_z \psi_+^i) \right. \\ \left. - R_{i\bar{i}j\bar{j}} \psi_+^i \psi_+^{\bar{i}} \psi_-^j \psi_-^{\bar{j}} \right) \end{aligned} \quad (13.36)$$

In deriving this one uses the basic formulae of Kähler geometry:

$$\begin{aligned} G_{i\bar{j}} &= \partial_i \partial_{\bar{j}} K(\Phi^i, \Phi^{\bar{i}}) \\ \Gamma_{jk}^i &= G^{i\bar{l}} \partial_j G_{k\bar{l}} \\ \Gamma_{j\bar{k}}^i &= 0 \quad \text{etc.} \\ R_{i\bar{j}k\bar{l}} &= -G_{m\bar{j}} \partial_{\bar{l}} \Gamma_{ik}^m \\ R_{i\bar{j}k\bar{l}} &= -R_{\bar{j}ik\bar{l}} = -R_{i\bar{j}l\bar{k}} = R_{k\bar{l}i\bar{j}} \end{aligned}$$

(13.37)

13.10.3. Symmetries

The symmetries of the action include $N = 2$ supersymmetry with

$$\{Q_+, \bar{Q}_+\} = H + P \quad \{Q_-, \bar{Q}_-\} = H - P$$

and a $U(1)_L \times U(1)_R$ R-symmetry:

$$\begin{aligned} U(1)_L : \psi_-^j &\rightarrow e^{i\alpha} \psi_-^j & \psi_-^{\bar{j}} &\rightarrow e^{-i\alpha} \psi_-^{\bar{j}} \\ J^{(L)} &= G_{i\bar{j}} \psi_-^i \psi_-^{\bar{j}} \\ U(1)_R : \psi_+^j &\rightarrow e^{i\alpha} \psi_+^j & \psi_+^{\bar{j}} &\rightarrow e^{-i\alpha} \psi_+^{\bar{j}} \\ J^{(R)} &= G_{i\bar{j}} \psi_+^i \psi_+^{\bar{j}} \end{aligned} \quad (13.38)$$

These currents are anomalous, but the vectorlike symmetry $J = J^{(L)} - J^{(R)}$ is anomaly free.

13.10.4. Topological twisting

The topological theory is defined by making a redefinition of the energy momentum tensor [219]:

$$T'_{\alpha\beta} = T_{\alpha\beta} - \frac{1}{2}\epsilon_{\alpha}{}^{\gamma}\partial_{\gamma}J_{\beta} \quad (13.39)$$

This is often called the *A-model* [230]. (13.39) defines a different coupling to gravity and consistency requires that objects which are charged under J change their transformation laws. Before twisting Q_+, Q_-, \bar{Q}_+ , and \bar{Q}_- transform under $U(1)_L \times U(1)_R \times SO(2)_{\text{localLorentz}}$ as

$$(1, 0, \frac{1}{2}) \oplus (0, 1, -\frac{1}{2}) \oplus (-1, 0, \frac{1}{2}) \oplus (0, -1, -\frac{1}{2}) \quad (13.40)$$

After twisting the four supercharges transform as:

$$(0, +1, 0) \oplus (0, -1, +1) \oplus (+1, 0, -1) \oplus (-1, 0, 0) \quad (13.41)$$

giving *two* scalar supercharges Q_+ and \bar{Q}_- . The operator $Q = Q_+ + \bar{Q}_-$ is nilpotent: $Q^2 = 0$ and the energy momentum tensor is Q -exact, $T'_{\alpha\beta} = \{Q, \Lambda_{\alpha\beta}\}$.

Another way of understanding the twisting procedure is that we couple the theory to an external $U(1)$ gauge field A_{μ} , so that correlators now depend on A_{μ} as well as the spin connection:

$$\langle \prod \mathcal{O} \rangle_{\omega_{\mu}, A_{\mu}}^{\text{N}=2 \text{ model}} \quad (13.42)$$

The “diagonal correlators” with $A_{\mu} \sim \frac{1}{2}\omega_{\mu}$ of local operators, \mathcal{O} , which are “chiral primary fields” [133] are the topological correlators. To see the equivalence of these viewpoints note that coupling to the current adds to the Lagrangian:

$$A_z \psi_-^i \psi_{-i} + A_{\bar{z}} \psi_+^i \psi_{+i} \quad (13.43)$$

Setting the gauge fields to be:

$$A_z = -\frac{i}{2}\omega_z \quad A_{\bar{z}} = +\frac{i}{2}\omega_{\bar{z}} \quad (13.44)$$

is equivalent to the redefinition of the stress-tensor in (13.39). The extra coupling (13.43) modifies the covariant derivatives in the Lagrangian change in a way compatible with (13.39).

From either point of view, the fermions change according to:

$$\psi_+{}^i \rightarrow \chi^i \quad \psi_+{}^{\bar{i}} \rightarrow \rho_z{}^{\bar{i}} \quad \psi_-{}^i \rightarrow \rho_z{}^{\bar{i}} \quad \psi_-{}^{\bar{i}} \rightarrow \chi^{\bar{i}} \quad (13.45)$$

It is important to note that the overall fermion determinant in the A model is an absolute square, since the $(\chi^i, \rho_z{}^{\bar{i}})$ and $(\chi^{\bar{i}}, \rho_z{}^i)$ are complex conjugates of one another. Hence there is no problem in making sense out of this determinant and actually this theory is well defined on arbitrary almost complex manifolds.

One might now wonder whether other twistings of the $N = 2$ theories lead to consistent theories. Since the (worldsheet) spin content of the theory changes linearly with the twisting, it seems reasonable to restrict attention to integral or half-integral twists, in order that we end up with integer or half-integer spin particle content. A half-integral axial twist of the energy-momentum tensor defines what is known as the B -model [230]. The particle content of this model includes chiral fermions (sections of $T^{(0,1)}X$), for which the fermion determinant is in general afflicted with an anomaly. As a result, the B model is well-defined only on Ricci-flat Kähler target spaces.

13.10.5. Comparison to the MQ form

Let us now compare the Lagrangian (13.36) above, after twisting, with (13.15) and (13.16). The purely bosonic terms differ slightly, but we may write:

$$\int \sqrt{h} d^2 z \, h^{\alpha\beta} G_{i\bar{j}} \partial_\alpha f^i \partial_\beta f^{\bar{j}} = \frac{1}{2} \int d^2 z \, G_{i\bar{j}} \bar{\partial} f^i \partial f^{\bar{j}} + \frac{1}{2} \int f^* \mathbf{K} \quad (13.46)$$

where $\mathbf{K} = \frac{i}{2} G_{i\bar{j}} dw^i \wedge d\bar{w}^{\bar{j}}$ is the Kähler form on the target. The second term on the RHS of (13.46) only depends on the homotopy class of f and on the cohomology class of \mathbf{K} . As discussed above, the space of holomorphic maps, $\mathcal{H}(\Sigma, X)$, has many components corresponding to the different homotopy classes of f . The second term becomes a constant on each component of fieldspace and simply provides a weighting factor for these different components.

Finally, putting together (13.46), (13.45), and (13.36), and identifying $s_{\bar{z}}^i = \partial_{\bar{z}} f^i$ we obtain precisely the action for the MQ form (13.16).

13.11. Canonical approach

The canonical approach is a very interesting application of the supersymmetric quantum mechanics approach to Morse theory, and involves symplectic Floer homology. We shall not enter into a thorough discussion of this subject here. Some references include [80,81,188,189,139].

From the point of view of the twisted physical σ -model, recall that in the case of SQM we found that if we restrict our attention to the $E = 0$ sector of the Hilbert space (i.e. states annihilated by Q and Q^*) then the partition function yields topological information, the index of Q . Analogously in the present case, the restriction to (chiral, chiral) primary fields [133] (i.e. states in the cohomology of $Q = Q_+ + \bar{Q}_+$) leads to correlation functions which yield topological information about the moduli space, $\mathcal{H}(\Sigma, X)$.

13.12. Appendix: Examples of Moduli spaces of Holomorphic Maps

In this appendix we illustrate the above formal constructions with some examples of spaces $\mathcal{H}(\Sigma, X)$.

1. Our first example will be rational maps from $\mathbb{C}P^1 \rightarrow \mathbb{C}P^1$. These are given by $f(z) = P(z)/Q(z)$ where P, Q are polynomials of degree n . The nonnegative integer n is the degree of f . The polynomials may be factorized so that

$$f(z) = A \frac{\prod_{i=1}^n (z - a_i)}{\prod_{i=1}^n (z - b_i)}$$

The moduli space breaks up into components labelled by $n \in \mathbb{Z}_+$. The n^{th} component of the moduli space may be described as:

$$\{(A, a_i, b_i) \in \mathbb{C}^{2n+1} \mid a_i \neq b_j, A \neq 0\} \quad (13.47)$$

Each component is noncompact and may be parametrized by the $2n + 1$ complex parameters A, a_i, b_i . In this case $H^1(f^*(TX))$ is zero so we may also obtain the dimension directly from the index theorem. This example illustrates two important properties of $\mathcal{H}(\Sigma, X)$. First there are many components. Second, the space is noncompact. The intersection theory is not well-defined until some compactification is chosen [149,185,139,156].

2. X is a Riemann surface of genus G and f a map of degree n . Then (13.27) becomes

$$\text{ind}_{\mathbb{C}} D_{\bar{z}} = B - 3(h - 1), \quad (13.48)$$

where we have applied the Riemann-Hurwitz relation to express the result in terms of the branching number $B = 2(h - 1) - 2n(G - 1)$. For $G > 1$ one can show that $H^0(f^*(TX)) = 0$, so there are ρ zero modes but no χ zero modes. The fact that there are no χ zero modes means the moduli space is zero dimensional. Thus it can be empty $\mathcal{H}(\Sigma, X) = \emptyset$, or $\mathcal{H}(\Sigma, X)$ is a discrete set of points. All this is consistent with the discussion in chapter 5 above. In fact, from the above discussion we see there are at most a finite set of points. This is just as well, for $G > 1$ the sigma model has constant negative curvature and its status as a quantum field theory, before twisting, is rather unclear.

3. One important example is the case of a topological sigma model based on a Calabi-Yau manifold of complex dimension d . The first Chern class of a Calabi-Yau vanishes, hence the complex index is $d(1 - h)$.

14. Topological Theories with Local Symmetry

When constructing actions for topological theories with gauge invariance one meets two basic constructions. The first, discussed in chapter 11, is the MQ construction localizing to the set of fields satisfying some basic equations. The second, discussed in this chapter, is connected with gauge invariance. The essential principle motivating the second construction is that of *spacetime locality*. We will explain the second construction in abstract terms. The same construction applies to all topological theories with local gauge invariance. We have attempted to explain the construction at length and in detail since we have found various points quite confusing.

14.1. Projection and Localization

Let us return to fig. 24 of chapter 9. The moduli spaces of interest are obtained by restricting fields Φ to $D\Phi = 0$, and then dividing by G . These moduli spaces form a submanifold $\mathcal{Z} \subset M$, where $M = P/G$ is naturally viewed as a quotient of a principal bundle³³ The key examples we will discuss are:

1. Topological Yang-Mills theory: Here P is \mathcal{A} , the space of all connections and G is \mathcal{G} the space of gauge transformations.

$$\mathcal{Z} \subset B\mathcal{G} = \mathcal{A}/\mathcal{G}$$

³³ This holds true away from points in M where the action of G is not free.

is defined by, for example,

$$\mathcal{Z} = \{A \in \mathcal{A} \mid F(A) = - * F(A)\}/\mathcal{G} \quad (14.1)$$

in the example of 4-dimensional Donaldson theory.

2. Topological Gravity: Here P is $\text{MET}(\Sigma)$ and G is $\text{Diff}(\Sigma)$ and we may take:

$$\mathcal{Z} \subset \text{MET}(\Sigma)/\text{Diff}(\Sigma)$$

to be defined by

$$\mathcal{Z} = \{h \in \text{MET}(\Sigma) \mid R(h) = k\}/\text{Diff}(\Sigma) \quad (14.2)$$

where the Ricci scalar is restricted to be $k = \pm 1$ or 0 , depending on the genus of Σ .

3. Topological string theory: Here P is $\text{MAP}(\Sigma, X) \times \text{MET}(\Sigma)$ and G is $\text{Diff}(\Sigma)$ and

$$\mathcal{Z} \subset \frac{\text{MAP}(\Sigma, X) \times \text{MET}(\Sigma)}{\text{Diff}(\Sigma)}$$

is the moduli space of holomorphic maps defined by

$$\mathcal{Z} = \{(f, h) \in \text{MAP} \times \text{MET} \mid R(h) = \pm 1, 0 \text{ and } df + Jdf\epsilon = 0\}/G \quad (14.3)$$

In all these cases, \mathcal{Z} is obtained by dividing the solutions of a *gauge invariant* equation by the action of the group of gauge transformations³⁴. In the above situations we see that \mathcal{Z} can be described in terms of the vanishing of a section of a vector bundle as follows. The equations (14.1), (14.2) and (14.3) define a section, s , of a vector bundle

$$\mathcal{V} \rightarrow P \quad (14.4)$$

The zero set, $\mathcal{Z}(s)$, is gauge invariant and

$$\mathcal{Z} = \mathcal{Z}(s)/G \quad . \quad (14.5)$$

Since we are writing gauge-covariant equations, the vector bundle, \mathcal{V} , and section, s , are *G-equivariant*. Thus if \mathcal{V} has standard fiber V , then V is in a representation ρ of G and we can define a bundle $E = \mathcal{V}/G \rightarrow M = P/G$ as in³⁵:

$$\begin{array}{ccc} \mathcal{V} & \xrightarrow{\pi_1} & P \\ \downarrow \pi_2 & & \downarrow \pi_3 \\ E = \mathcal{V}/G & \xrightarrow{\pi_4} & M = P/G \end{array} \quad (14.6)$$

³⁴ N.B. Although the principal bundle P and group G are infinite dimensional the spaces \mathcal{Z} are all finite dimensional.

³⁵ In Donaldson theory $\mathcal{V} = P \times V$ is naturally trivial over P , but in topological string theory this is not the case.

Moreover, as in (A.6) below, if $s: P \rightarrow \mathcal{V}$ is a G -equivariant section, then

$$s(p \cdot g) = \rho(g^{-1}) \cdot s(p) \quad (14.7)$$

Hence, by (A.6) we see that s descends to a section \bar{s} of E . The situation is summarized by

$$\begin{array}{ccc} \mathcal{V} & \xleftarrow{s} & P \\ \downarrow \pi_2 & & \downarrow \pi_3 \\ E & \xleftarrow{\bar{s}} & M = P/G \end{array} \quad (14.8)$$

In particular, $\mathcal{Z}(s)/G = \mathcal{Z}(\bar{s})$.

The topological field theory path integral essentially constructs a MQ form for E , $\bar{s}^*(\Phi(E; \nabla))$, for some connection ∇ on E . The intersection numbers of homology classes $H_{\mathcal{O}_i} \in H_\bullet(\mathcal{Z})$ dual to $\mathcal{O}_i \in H^\bullet(\mathcal{Z})$ are, as usual³⁶:

$$\begin{aligned} \#(H_{\mathcal{O}_1} \cap \cdots \cap H_{\mathcal{O}_k} \cap D) &\equiv \int_{\mathcal{Z}(\bar{s})} \mathcal{O}_1 \wedge \cdots \wedge \mathcal{O}_k \chi(\text{cok}(\nabla \bar{s}) \rightarrow \mathcal{Z}(\bar{s})) \\ &= \int_{M=P/G} \bar{s}^*(\Phi(E, \nabla)) \wedge \mathcal{O}_1 \wedge \cdots \wedge \mathcal{O}_k \end{aligned} \quad (14.9)$$

Here D is Poincaré dual to χ .

Topological field theory provides expressions for these integrals in terms of *local* quantum field theory. In order to derive these expressions we must

1. Express the integral over P , not $M = P/G$
2. Choose a connection ∇ on E and write $\Phi(E, \nabla)$ as a path integral.

The first issue is quite familiar from ordinary gauge theory. Conceptually, correlation functions of gauge invariant operators, \mathcal{O} , such as Wilson loops, are integrals over gauge inequivalent fields. In local field theory we express this as an integral over all gauge fields and divide by $\text{vol } \mathcal{G}$. For example, in Yang-Mills theory we write

$$\langle \mathcal{O} \rangle = \int_{\mathcal{A}/\mathcal{G}} d\mu \mathcal{O} = \frac{1}{\text{vol } \mathcal{G}} \int_{\mathcal{A}} dA e^{-S_{Y.M.}} \mathcal{O} \quad (14.10)$$

We will first address point 1 in secs. 14.2 and 14.3 by trying to lift (14.9) to an integral over P . After that we address point 2 in sec. 14.4.

³⁶ For simplicity we denote $\mathcal{O}_i \in H^\bullet(M)$ and $i^*\mathcal{O}_i \in H^\bullet(\mathcal{Z})$ by the same thing, where i is the inclusion of $\mathcal{Z}(s)$ in M .

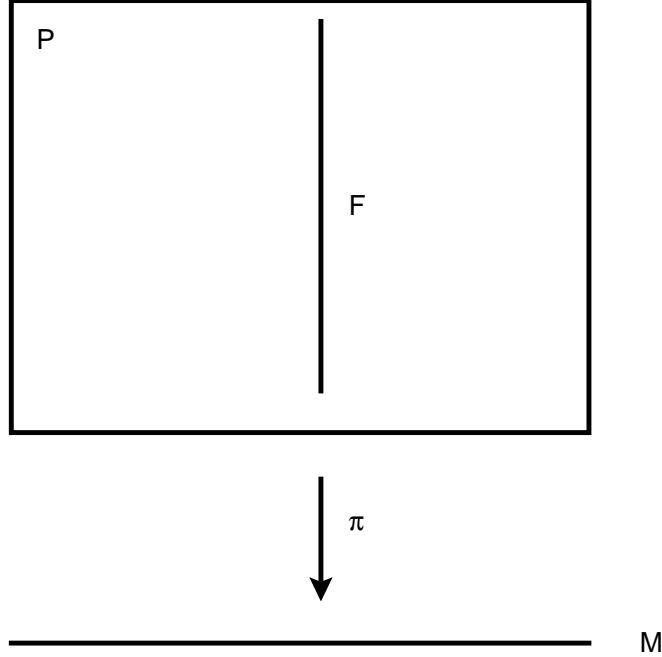

Fig. 32: Example of a projection.

14.2. The Projection Form

Consider the fibration $P \rightarrow M$ as shown in fig. 32. The fiber might be a vector space (for a vector bundle) or a Lie group (for a principal bundle). Here the basic problem is: given a form ξ on the base M , how can we write $\int_M \xi$ as an integral over P ? We will search for a construction of a cohomology class $\Phi(P \rightarrow M)$, such that for $\xi \in H^\bullet(M)$

$$\int_M \xi = \int_P \pi^* \xi \wedge \Phi(P \rightarrow M) \quad . \quad (14.11)$$

In fact, we will find it much more natural to phrase the problem of constructing a projection form in the framework of *equivariant cohomology*. Thus, we will search for an equivariant differential form $\Phi(P \rightarrow M) \in \Omega_G^\bullet(P)$ such that

$$\int_M \xi = \oint_{\epsilon=0, P} \pi^* \xi \wedge \Phi(P \rightarrow M) \quad (14.12)$$

where we are using equivariant integration defined in section 11.12.2 above.

Remarks

1. As noted in [227], the limit $\epsilon \rightarrow 0$ is usually a singular limit. We will find that Φ is a distribution in ϕ so the convergence factor is not needed (See, however, remark 14.3.3.3 below.)

2. What we are doing is *not* the same as Faddeev-Popov (FP) gauge-fixing. There, one is given a natural measure dA on P and one wishes to construct a measure $d\mu$ on \mathcal{A}/\mathcal{G} so that $dA = \pi^*(d\mu) \wedge \mu_{\text{Haar}}$. The FP construction involves (among other things) an explicit choice of slice, and a different multiplet of (anti-)ghosts. We describe the FP procedure, from the point of view of these lectures, in section 14.5 below.

14.3. A BRST Construction of $\Phi(P \rightarrow M)$ for Principal Bundles

14.3.1. Characterization of $\Phi(P \rightarrow M)$

The essential point is that $\Phi(P \rightarrow M)$ in (14.12) must contain all the vertical directions on the principal bundle. Recall from sec. A.3.2 below that for any principal bundle, and point $p \in P$ we have a canonical mapping

$$C_p = dR_p : \underline{\mathfrak{g}} \rightarrow T_p P \quad (14.13)$$

The image of C_p is the space of vertical vectors, $(T_p P)^{\text{vert}}$.

One way to solve the problem posed in the previous section is to find an equivariant differential form $\Phi(P \rightarrow M) \in \Omega_G(P)$ that satisfies the three criteria:

- (i) $\Phi(P \rightarrow M) \in \Lambda^{\max}(T^* P)^{\text{vert}}$
- (ii) $d_C \Phi = 0$, where d_C is the Cartan differential (10.16), i.e., Φ is equivariantly closed.
- (iii) $\forall p \in P, R_p^* \Phi = \mu_{\text{Haar}}$ where μ_{Haar} is a normalized equivariant Haar measure for G .

By an equivariant Haar measure we mean an equivariant differential form on G such that

$$\oint_{\epsilon, G} \mu_{\text{Haar}} = 1 \quad (14.14)$$

The three criteria i,ii, and iii are in close analogy to the three criteria of section 11.2 characterizing the universal Thom class. Let us check that these three conditions guarantee that Φ satisfies (14.12). Condition (ii) is required since the LHS of (14.12) depends only on the cohomology class of ξ . If F is a compactly supported form on M then³⁷ $\oint_{\epsilon=0, P} \pi^*(dF) \Phi(P \rightarrow M) = \oint_{\epsilon=0, P} D\pi^*(F) \Phi(P \rightarrow M) = 0$. To integrate over the fibers choose a local trivialization $t : (x, g) \rightarrow R_{s(x)}(g)$ of $\pi^{-1}(U)$ for a patch U in M . (R_p is defined in (A.14).) Using (i) and (iii), one easily checks that the integral over the fiber directions is 1.

In the next two sections we show that one can construct Φ given a G -invariant metric on P .

³⁷ Note that pullback commutes with d , so that $\pi^* d = d\pi^*$; while the image of π^* is basic, so that $d\pi^* = D\pi^*$.

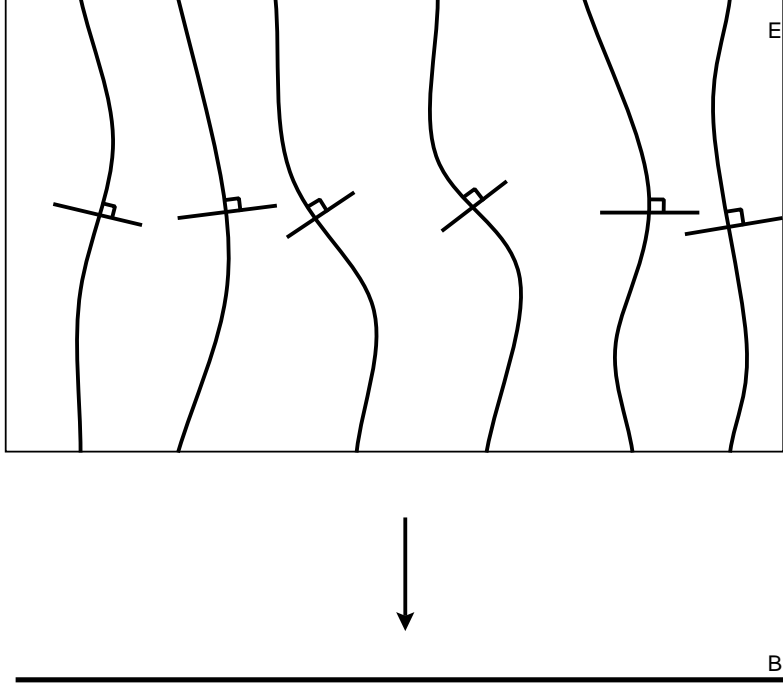

Fig. 33: Orthogonal complements to gauge orbits define a connection.

14.3.2. Geometry of Principal Bundles

We first review some of the differential geometry of principal bundles. The essential fact is that, given a G -invariant metric $(\cdot, \cdot)_{TP}$ on a principal bundle, there is automatically associated to it a natural connection. As we have seen in A.3, a connection is simply a G -equivariant choice of horizontal tangent vectors. Using a G -invariant metric one simply defines the connection by declaring the horizontal subspaces to be the orthogonal complements to the gauge orbits as in fig. 33.

As we showed in section A.3.2 we always have a map $C_p : \mathfrak{g} \rightarrow T_p P$ as in (A.15). Because we have a metric there is an adjoint, defining a Lie-algebra valued 1-form:

$$C_p^\dagger : T_p P \rightarrow \mathfrak{g} \quad (14.15)$$

In terms of C and C^\dagger

$$\Pi^v = C \frac{1}{C^\dagger C} C^\dagger \quad (14.16)$$

is the projection onto the vertical tangent space and the connection is

$$\Theta = C^{-1} \Pi^v = \frac{1}{C^\dagger C} C^\dagger \quad . \quad (14.17)$$

G -invariance of the metric guarantees that (A.20) will be satisfied.

Exercise. Curvature

Show that, on horizontal tangent vectors

$$d\Theta(X, Y) = \frac{1}{C^\dagger C} dC^\dagger[X, Y]$$

14.3.3. Construction of Φ

To motivate the solution to the problem, we return to the Lie-algebra-valued 1-form, $C_p^\dagger \in T_p^*P \otimes \underline{\mathfrak{g}}$ defined in (14.15). To be explicit, let dp^i be a basis of one-forms on P . C^\dagger can be written as $T_a(C^\dagger)_i^a dp^i$. Moreover, $\ker C_p^\dagger = (T_p P)^{\text{horizontal}}$. Thus we should take a wedge product

$$C_p^\dagger \wedge \cdots \wedge C_p^\dagger$$

with one factor for each dimension of $(T_p P)^{\text{vertical}}$. Since $\underline{\mathfrak{g}} \cong (T_p P)^{\text{vertical}}$ we can use the metric on the Lie algebra, $\underline{\mathfrak{g}}, (\cdot, \cdot)_{\underline{\mathfrak{g}}}$ to contract the Lie algebra indices to get a vertical form³⁸. The contraction of Lie algebra indices is most elegantly done by introducing odd vectors $\eta_a \in \Pi \underline{\mathfrak{g}}$ corresponding to an ON basis of $\underline{\mathfrak{g}}$ and forming:

$$\int_{\Pi \underline{\mathfrak{g}}} d\eta e^{(\eta, C_p^\dagger)_{\underline{\mathfrak{g}}}} \in \Lambda^\bullet(T_p^*P)^{\text{vertical}}. \quad (14.18)$$

The problem is that this form is not closed, and does not satisfy criterion (iii).

The above two problems can be fixed by introducing a BRST exact action. We now take the complex to be:

$$C_{\text{projection}}^* = S(\underline{\mathfrak{g}}^*) \otimes \Omega^\bullet(P) \otimes (S(\underline{\mathfrak{g}}) \otimes \Lambda(\underline{\mathfrak{g}})) \quad (14.19)$$

The first two factors are identified with the Cartan-model complex of equivariant cohomology while the last two factors admit an action of $\underline{\mathfrak{g}}$ from the adjoint representation. We introduce generators λ_a and η_a of ghost number -2 and -1 , respectively, for the last two factors. Then we can augment the Cartan differential on the first two factors by³⁹

$$Q_C = d_C \otimes 1 + 1 \otimes \delta$$

$$Q_C \begin{pmatrix} \lambda_a \\ \eta_a \end{pmatrix} = \begin{pmatrix} 0 & 1 \\ -\mathcal{L}_\phi & 0 \end{pmatrix} \begin{pmatrix} \lambda_a \\ \eta_a \end{pmatrix} \quad (14.20)$$

³⁸ This assumes that G acts freely. In the case of topological Yang-Mills, the group of gauge transformations does not act freely on reducible connections.

³⁹ Note that $\phi \in \underline{\mathfrak{g}}^*$, so we must understand $\mathcal{L}_\phi \lambda = [\phi, \lambda] \in \underline{\mathfrak{g}}^*$ as a coadjoint action. We then must use the metric on $\underline{\mathfrak{g}}$ to identify $[\phi, \lambda] \in \underline{\mathfrak{g}}$. In what follows we will use the metric on $\underline{\mathfrak{g}}$ to identify $\phi \in \underline{\mathfrak{g}}$.

Note that $Q_C^2 = 0$ only on the G -invariant subcomplex.

Using the metric on $\underline{\mathbf{g}}$ we can contract C^\dagger with λ to obtain an element of $\Omega(P) \otimes S(\underline{\mathbf{g}})$. The contraction is

$$(\lambda, C^\dagger)_{\underline{\mathbf{g}}} = \lambda_a (C^\dagger)_i^a dp^i \quad (14.21)$$

where λ_a are coordinates with respect to an ON basis.

Proposition: The form

$$\begin{aligned} \Phi_{\text{projection}}(P \rightarrow M) &= \left(\frac{1}{2\pi i}\right)^{\dim G} \int_{\widehat{\underline{\mathbf{g}}}} d\lambda d\eta e^{Q_C \Psi_{\text{projection}}} \\ \Psi_{\text{projection}} &= i(\lambda, C^\dagger)_{\underline{\mathbf{g}}} \in \Omega^1(P) \end{aligned} \quad (14.22)$$

satisfies criteria (i), (ii) and (iii) above and therefore is a representative of a projection form, $\Phi(P \rightarrow M)$. Here $Q_C = 1 \otimes d \otimes 1 - \iota_\phi \otimes 1 \otimes 1 + 1 \otimes 1 \otimes \delta$ on (14.19).

Proof: To prove property (i) we expand:

$$Q_C(\lambda, C^\dagger)_{\underline{\mathbf{g}}} = (\eta, C^\dagger)_{\underline{\mathbf{g}}} + (\lambda, dC^\dagger)_{\underline{\mathbf{g}}} + (\lambda, C^\dagger C\phi)_{\underline{\mathbf{g}}} \quad (14.23)$$

The second and third terms arise from the Cartan differential on $\Omega^\bullet(P)$. To justify the third term write: $\lambda_a (C^\dagger)_i^a \iota_\phi dp^i = \lambda_a (C^\dagger)_i^a (C\phi)^i = (\lambda, C^\dagger C\phi)$, where ϕ is considered in $\underline{\mathbf{g}}$. Thus we have:

$$\begin{aligned} \int_{\widehat{\underline{\mathbf{g}}}} d\lambda d\eta e^{Q_C \Psi} &= (2\pi)^{\dim G} \int_{\Pi_{\underline{\mathbf{g}}}} d\eta e^{i(\eta, C^\dagger)_{\underline{\mathbf{g}}}} \delta(C^\dagger C\phi + dC^\dagger) \\ &= (2\pi)^{\dim G} \delta(C^\dagger C\phi + dC^\dagger) \int_{\Pi_{\underline{\mathbf{g}}}} d\eta e^{i(\eta, C^\dagger)_{\underline{\mathbf{g}}}} \end{aligned} \quad (14.24)$$

is a top vertical form. Hence it is manifest that (i) is satisfied.

To prove equivariant closure we write, in analogy to (11.20):

$$\begin{aligned} d_C \int d\lambda d\eta e^{Q_C(\Psi)} &= \int d\lambda d\eta [Q_C - \delta] e^{Q_C(\Psi)} \\ &= \int d\lambda d\eta [-\delta] e^{Q_C(\Psi)} \end{aligned} \quad (14.25)$$

where we have used $Q_C^2 = -\mathcal{L}_\phi$ which vanishes on Ψ . Moreover, δ acts as:

$$\delta = \eta_a \frac{\partial}{\partial \lambda_a} - f_{bc}^a \phi_b \lambda_c \frac{\partial}{\partial \eta_a}$$

so we may drop this operator by the properties of the Berezin integral. Thus Φ is equivariantly closed, $d_C \Phi = 0$.

It remains to check that the form is properly normalized, property (iii). To see this note that $R_p^* C^\dagger$ is a left-invariant 1-form on G with values in the Lie algebra \mathfrak{g} . The value of this form on a tangent vector $X_e \in T_e G$ may be computed from

$$\langle R^* C^\dagger, X_e \rangle = \langle C^\dagger, R_* X_e \rangle = \langle C^\dagger, C X_e \rangle = C^\dagger C X$$

where in the last equality we have used the isomorphism $T_e G \cong \mathfrak{g}$. It follows that, if θ^a is an ON basis of left-invariant 1-forms on G dual to a basis T_a for \mathfrak{g} , then

$$R_p^* C^\dagger = \sum_a C^\dagger C(T_a) \theta^a \in \Omega^1(G; \mathfrak{g})$$

and

$$\begin{aligned} R_p^* \int_{\Pi \mathfrak{g}} d\eta e^{i(\eta, C^\dagger)_{\mathfrak{g}}} &= \int_{\Pi \mathfrak{g}} d\eta e^{i(\eta, R_p^* C^\dagger)_{\mathfrak{g}}} \\ &= i^{\dim G} \det(C^\dagger C) \theta^1 \wedge \dots \wedge \theta^{\dim G} \end{aligned} \tag{14.26}$$

where $\theta^1 \wedge \dots \wedge \theta^{\dim G}$ is the normalized Haar measure on G . Combining this with (14.24) shows that Φ pulls back to a correctly normalized equivariant Haar measure, thus completing the proof. ♠

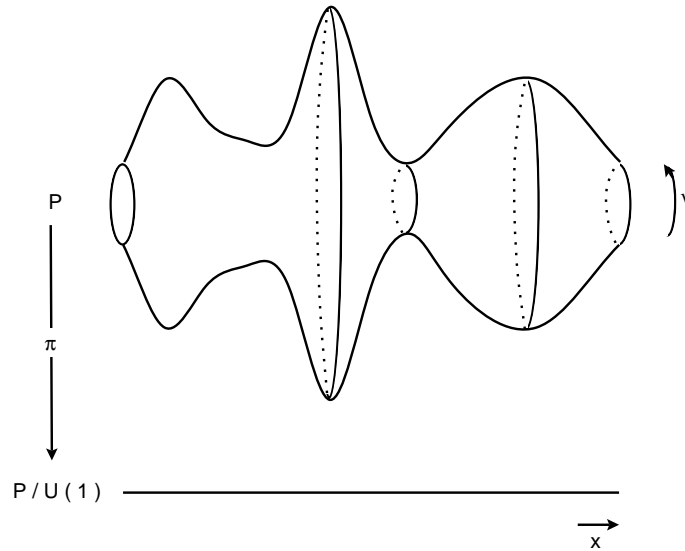

Fig. 34: A circle bundle with metric.

Example: Consider a principal $U(1)$ bundle, P , with coordinates (x, ν) . x is a coordinate on the base and $0 \leq \nu < 2\pi$ is a periodic fiber coordinate. P has an invariant metric $dx^2 + g(x)d\nu^2$, so the circles have a variable radius as in fig. 34.

The standard coordinate on the group $U(1)$ will be called θ . The Lie algebra is $\mathbb{R} \cdot \frac{\partial}{\partial \theta}$. Then we may easily compute⁴⁰:

$$\begin{aligned} R_{x,\nu}(e^{i\theta}) &= (x, \nu + \theta) \\ C: \frac{\partial}{\partial \theta} &\rightarrow \frac{\partial}{\partial \nu} \\ C^\dagger &= g(x) \frac{d\nu}{2\pi} \otimes \frac{\partial}{\partial \theta} \\ C^\dagger C &= g(x) \end{aligned} \tag{14.27}$$

It is easily seen that

$$\int d\eta e^{i(\eta \frac{\partial}{\partial \theta}, C^\dagger)_{u(1)}} = ig(x)d\nu \tag{14.28}$$

does not satisfy good properties. For example, if $F(x)$ is compactly supported there is no reason for $\int_P \pi^*(dF(x))g(x)d\nu$ to vanish. On the other hand, one easily checks:

$$\frac{1}{2\pi i} \int d\eta d\lambda e^{iQ(\lambda, C^\dagger)_{u(1)}} = \frac{d\nu}{2\pi} g(x) \delta[g(x)\phi - g'(x)dx d\nu] \tag{14.29}$$

which satisfies

$$\oint_{\epsilon=0, U(1)} \frac{d\nu}{2\pi} g(x) \delta[g(x)\phi - g'(x)dx d\nu] = 1. \tag{14.30}$$

Remark 14.3.3.1: Note that one by-product of the above discussion is that the integral over ϕ is delta-function supported on

$$\phi \rightarrow -\frac{1}{C^\dagger C} dC^\dagger$$

which is the horizontal part of the curvature of $P \rightarrow M$

Remark 14.3.3.2: In 2D gravity the metric on the diffeomorphism group is *not* Weyl invariant. This leads to extra complications when trying to interpret the Weyl group as a gauge group.

⁴⁰ The normalization for the dual pairing has been chosen to be $\langle d\nu, \frac{\partial}{\partial \nu} \rangle = 2\pi$

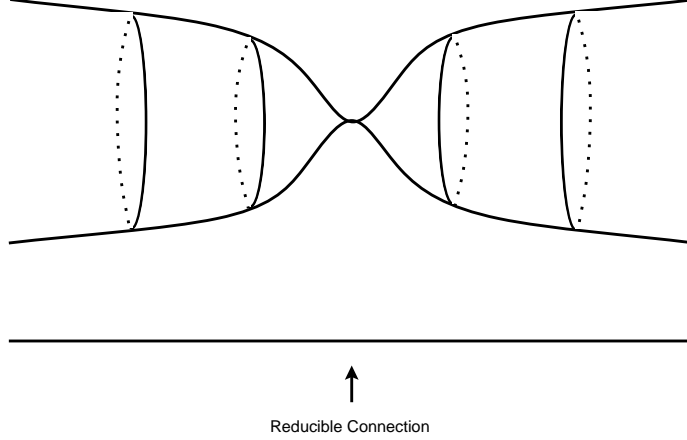

Fig. 35: A circle bundle with metric.

Remark 14.3.3.3.

One of the main technical obstacles in Donaldson theory is the problem that on subspaces of “reducible gauge connections” the operator $C^\dagger C$ has zero modes, rendering the above and subsequent discussions more complicated. A picture of what happens over a reducible connection is the following. We lose some dimensions in the fiber and the volume collapses to zero as in fig. 35. It might be of interest to regulate these singularities using $\epsilon > 0$ in (14.12). In topological Yang-Mills a closely related idea of adding a mass term to the topological Lagrangian has led to some success [233].

14.4. Assembling the Pieces: No Gauge Fixing.

Now that we have constructed the projection form let us return to the problem of writing (14.9) as a field theory correlator with Q -exact action. Consider again (14.6) and (14.8) and denote the group G by G_{gauge} . We use the projection form to write (14.9) as an integral over P :

$$\begin{aligned}
 & \int_{M=P/G_{\text{gauge}}} \bar{s}^*(\Phi(E, \nabla)) \wedge \bigwedge_i \mathcal{O}_i \\
 &= \oint_P \pi_3^*(\bar{s}^*(\Phi(E, \nabla))) \wedge \Phi_{\text{projection}}(P \rightarrow M) \wedge \bigwedge_i \pi_3^*(\mathcal{O}_i)
 \end{aligned}
 \tag{14.31}$$

where the projections are defined in (14.6) above. The classes \mathcal{O}_i are more naturally expressed in terms of their pullbacks: $\pi_3^*(\mathcal{O}_i)$. These pullbacks will be local operators in the field theory. We will denote these by $\tilde{\mathcal{O}}_i$.

14.4.1. Equivariant Thom Class

Finally we must choose a connection ∇ on E and build the MQ form. Suppose first that we were trying to construct the MQ form for $\mathcal{V} \rightarrow P$, and were trying to localize to $\mathcal{Z}(s)$. In this case we would follow the logic of chapter 11. Let \mathcal{V} have standard fiber V with a metric $(\cdot, \cdot)_V$, defining an orthogonal group $SO(V)$. The bundle $\mathcal{V} \rightarrow P$ is itself associated to a principal $SO(V)$ bundle $\tilde{P} \rightarrow P$:

$$\begin{array}{ccc} \tilde{P} \times V & \longrightarrow & \tilde{P} \\ \downarrow \tilde{\pi}_2 & & \downarrow \tilde{\pi}_3 \\ \mathcal{V} = \tilde{P} \times_{SO(V)} V & \xrightarrow{\pi_1} & P = \tilde{P}/SO(V). \end{array} \quad (14.32)$$

Choose an $SO(V)$ connection ∇_s . Then corresponding to a universal Thom class, U_s , in $SO(V)$ -equivariant cohomology we use

$$w_s(U_s) = \tilde{\pi}_2^*(\Phi(\mathcal{V}, \nabla_s)),$$

to obtain $\Phi(\mathcal{V}, \nabla_s) \in \Omega_{SO(V)}^\bullet(\tilde{P} \times V)$. However, we are *not* trying to localize to $\mathcal{Z}(s)$ but to $\mathcal{Z}(\bar{s})$. Moreover, ∇_s does *not* simply descend to a connection on E . Even if \mathcal{V} were trivial, i.e. $\mathcal{V} = P \times V$, then $E = \mathcal{V}/G_{\text{gauge}}$ would still have a nontrivial connection ∇_g , since it is associated to the principal bundle $P \rightarrow P/G_{\text{gauge}}$. As we saw in section 14.3.2 above P has a nontrivial connection. We must account for both $SO(V)$ and G_{gauge} .

We see that there are *two groups* involved in the construction of the MQ class of E and that the relevant universal Thom class U_{total} is constructed using $G_{\text{total}} = SO(V) \times G_{\text{gauge}}$ -equivariant cohomology. The fiber V is a representation of G_{total} . The formulae above continue to hold, but we must remember that a Weil homomorphism involves a sum of connections and curvatures. That is, for instance

$$\begin{aligned} \nabla &= \nabla_s \oplus \nabla_g \\ R &= R_s + R_g \end{aligned} \quad (14.33)$$

$\bar{w}_s \bar{w}_g(U_{\text{total}})$ descends to a differential form $\Phi(E, \nabla_s \oplus \nabla_g)$ in $\Omega(E)$. The whole thing fits together as:

$$\begin{array}{ccc} \tilde{P} \times V & \longrightarrow & \tilde{P} \\ \downarrow \tilde{\pi}_2 & & \downarrow \tilde{\pi}_3 \\ \mathcal{V} = \tilde{P} \times_{SO(V)} V & \xrightarrow{\pi_1} & P = \tilde{P}/SO(V) \\ \downarrow \pi_2 & & \downarrow \pi_3 \\ E = \mathcal{V}/G_{\text{gauge}} & \xrightarrow{\pi_4} & M = P/G_{\text{gauge}} = \\ & & \tilde{P}/(SO(V) \times G_{\text{gauge}}) \end{array} \quad (14.34)$$

Although we have a sum of connections, from the point of view of field theory the nature of the two connections is very different. ∇_s involves local expressions in spacetime, while ∇_g is *nonlocal in spacetime*. The nonlocality of ∇_g is eliminated by lifting the form to P in the way we describe next.

Referring back to (14.8), we use the trivial observation: $\bar{s}\pi_3 = \pi_2s$, to write:

$$\pi_3^* \bar{s}^* \Phi(E, \nabla_s \oplus \nabla_g) = s^* \pi_2^* (\Phi(E, \nabla_s \oplus \nabla_g))$$

The form $\pi_2^* (\Phi(E, \nabla_s \oplus \nabla_g))$ is in $\Omega^\bullet(\mathcal{V})$ and arises from a Thom class for $SO(V) \oplus G_{\text{gauge}}$ -equivariant cohomology. Because it is inconvenient to make explicit horizontal projections, we use the *Weil model* for $SO(V)$ -cohomology. Thus we choose a connection ∇_s and corresponding Weil homomorphism w_s . On the other hand, because of the nonlocality of ∇_g it is convenient to use the *Cartan model* for G_{gauge} -equivariant cohomology. Thus, the universal Thom class will take values in the complex

$$U_{\text{total}} \in \mathcal{W}(so(V)) \otimes S(\underline{\mathfrak{g}}_{\text{gauge}}^*) \otimes \Omega^\bullet(V) \quad (14.35)$$

By applying w_s we have a form

$$\begin{aligned} U_{\text{gauge}} &\in S(\underline{\mathfrak{g}}_{\text{gauge}}^*) \otimes \Omega^\bullet(\mathcal{V}) \\ w_s(U_{\text{total}}) &= \tilde{\pi}_2^*(U_{\text{gauge}}) \end{aligned} \quad (14.36)$$

In fact, U_{gauge} will be $\underline{\mathfrak{g}}_{\text{gauge}}$ -invariant and hence is a G_{gauge} -equivariant form in $\Omega_{G_{\text{gauge}}}(\mathcal{V})$.

As we saw in section 11.6, when applying the Cartan model for the MQ form, we must take a horizontal projection. Thus strictly speaking we must choose a connection, ∇_g , corresponding to the Weil homomorphism w_g and consider $w_g(U_{\text{gauge}})^{\text{horizontal}} \Phi(P \rightarrow M)$ in (14.31).

At this point the projection form comes to the rescue. We need not apply w_g , nor need we enforce the horizontal projection. All of this is done automatically for us by the projection form $\Phi(P \rightarrow M)$. Being fully vertical we have:

$$w_g(U_{\text{gauge}})^{\text{horizontal}} \Phi(P \rightarrow M) = w_g(U_{\text{gauge}}) \Phi(P \rightarrow M) \quad (14.37)$$

Moreover, as we have seen in the previous section, Φ is δ -function supported on values of ϕ given by the curvature of $P \rightarrow P/G_{\text{gauge}}$, hence we needn't apply w_g .

Thus, we have finally found a home for $\pi_2^* (\Phi(E, \nabla_s \oplus \nabla_g))$. It should lie in the equivariant cohomology $\Omega_{G_{\text{gauge}}}(\mathcal{V})$ and can be identified with U_{gauge} which is related to U_{total} by (14.35) and (14.36). The pullback by s , $s^*(U_{\text{gauge}})$, will be an equivariant differential form on P .

14.4.2. Q -exact actions

We are now finally ready to express the intersection numbers (14.9) as correlators with a Q -exact action. We have managed to write the intersection numbers on \mathcal{Z} in terms of integration of equivariant differential forms on P , i.e. (14.9) can be written as:

$$\oint_{\epsilon=0, P} s^*(U_{\text{gauge}}) \wedge \Phi(P \rightarrow M) \wedge \bigwedge_{i=1}^k \tilde{\mathcal{O}}_i \quad (14.38)$$

By the results of the above sections, each of the first two factors can be written in QFT language in terms of a Q -exact action. Thus we have the general integral formula for the intersection numbers in $\mathcal{Z}(\bar{s}) \subset M$ generalizing (11.50):

$$\boxed{\langle \hat{\mathcal{O}}_1 \cdots \hat{\mathcal{O}}_k \rangle = \int_{\mathcal{Z}(\bar{s})} \tilde{\mathcal{O}}_1 \wedge \dots \wedge \tilde{\mathcal{O}}_k \chi(\text{cok}(\nabla \bar{s}))} \quad (14.39)$$

where $\hat{\mathcal{O}}_k$ are superspace representatives of the forms $\tilde{\mathcal{O}}_k$ and the measure for the correlation functions is:

$$\boxed{\langle \hat{\mathcal{O}} \rangle \equiv \frac{1}{\text{vol } \mathcal{G}} \int_{\underline{\mathbf{g}} \times \hat{\mathcal{S}}} d\phi \hat{\mu} e^{Q(\Psi)} \tilde{\mathcal{O}}} \quad (14.40)$$

where the superspace $\hat{\mathcal{S}} = \hat{\mathcal{V}}^* \times \underline{\mathbf{g}}$ has functions generated by coordinates A and ψ for the base, P , of \mathcal{V}^* , coordinates ρ and π for the fibers of \mathcal{V}^* , and coordinates λ and η for $\underline{\mathbf{g}}$. The superspace measure is standard:

$$\hat{\mu} = (dA d\psi)(d\pi d\rho)(d\lambda d\eta)$$

The action of Q will be the Cartan-model action for G_{gauge} -equivariant cohomology. We explicitly apply the Chern-Weil homomorphism to obtain the connection ∇_s and need not talk about $SO(V)$ -equivariant cohomology. Thus Q is defined by (11.22) and (14.20). Explicitly

$$Q = (d - \iota_\phi) \otimes 1 \otimes 1 + 1 \otimes Q_C \otimes 1 + 1 \otimes 1 \otimes \delta$$

on $(S(\underline{\mathbf{g}}_{\text{gauge}}^*) \otimes \hat{\mathcal{F}}(P)) \otimes \hat{\mathcal{F}}(V^*) \otimes \hat{\mathcal{F}}(\underline{\mathbf{g}}_{\text{gauge}})$. (We oversimplify somewhat assuming that $\mathcal{V}^* = P \times V^*$ is a trivial bundle.) The gauge fermion has the form:

$$\boxed{\Psi = \Psi_{\text{localization}} + \Psi_{\text{projection}}} \quad (14.41)$$

Here we may take from (14.22):

$$\Psi_{\text{projection}} = i(\lambda, C^\dagger)_{\underline{\mathfrak{g}}_{\text{gauge}}} \quad (14.42)$$

for the projection gauge fermion. The localization gauge fermion can be represented in many ways, as we saw above. In accord with (11.29), (14.35) we take:

$$\begin{aligned} \Psi_{\text{localization}} &= \rho_a (i s^a - t \theta^{ab} \rho_b + t \pi_a) \\ &= i \langle \rho, s \rangle - t(\rho, \theta \cdot \rho)_{V^*} + t(\rho, \pi)_{V^*} \end{aligned} \quad (14.43)$$

where θ refers to the $SO(V)$ connection ∇_s .

This representation will strike many readers as utterly bizarre, but we will see that correlation functions of topological field theories of cohomological type all fit into this scheme.

Remarks:

1. The measure $d\phi\hat{\mu}$ in (14.40) may look a little strange, especially since it appears that the number of fermionic and bosonic degrees of freedom differ. This is related to the use of the Cartan differential which does *not* square to zero, $Q^2 = -\mathcal{L}_\phi$, but is only zero on the invariant subcomplex. Since Q does not square to zero there need not be equality of degrees of freedom. If we work with the Weil model or the BRST model of equivariant cohomology, then we also introduce c^a , thus restoring the balance between commuting and anticommuting degrees of freedom.
2. The vector bundle, $\text{cok } \nabla \bar{s} \rightarrow \mathcal{Z}(\bar{s})$, is crucial in describing the above integrals, but the operator is somewhat awkward to work with. As usual, it is better to speak about $\nabla s : T_p P \rightarrow T_{s(p)} \mathcal{V}$. Since s is gauge-covariant this has ∞ -dimensional kernel and cokernel. However, the operator

$$\mathbb{O} = \left(\begin{array}{c} \nabla s \\ C^\dagger \end{array} \right) : T_p P \rightarrow T_{s(p)} \mathcal{V} \oplus \underline{\mathfrak{g}} \quad (14.44)$$

defines equivariant vector bundles, $\ker \mathbb{O}$ and $\text{cok } \mathbb{O}$, with *finite* dimensional fibers which descend to $\ker \nabla \bar{s}$ and $\text{cok } \nabla \bar{s}$. The operator \mathbb{O} is the operator appearing in the fermion kinetic terms in the complete lagrangian, and plays a crucial role in the following chapters.

3. As we will discuss in detail later the moduli spaces are in fact not smooth. This leads to extra complications. If there are orbifold singularities then we compute an orbifold Euler class in (14.39). For worse singularities we do not know a general prescription.

14.5. Faddeev-Popov Gauge Fixing

We now describe how the standard FP gauge-fixing procedure fits into the formalism of this paper. We will use the language of Yang-Mills theory although the same considerations apply to gravity.

What one would like to do is construct a measure $d\bar{\mu}$ on \mathcal{A}/\mathcal{G} such that we can identify

$$\pi^*(d\bar{\mu})d\mu_H = dA e^{-I_{Y.M.}} \quad (14.45)$$

where $d\mu_H$ is an A -independent standard Haar measure on the group.

In order to separate the gauge degrees of freedom from gauge inequivalent degrees of freedom one trivializes the principal bundle $\mathcal{A} \rightarrow \mathcal{A}/\mathcal{G}$. This can be done by choosing a local cross section, or, equivalently, by choosing a local slice $\mathcal{Z} \subset \mathcal{A}$.⁴¹

A local cross section can be defined by considering a gauge noninvariant function \mathcal{F} on \mathcal{A} . We will assume that \mathcal{F} takes its values in a vector space V , that is: $\mathcal{F}: \mathcal{A} \rightarrow V$. The statement that this defines a good gauge is the statement that

$$\forall A \in \mathcal{A} \quad \exists! \bar{g}_A \in \mathcal{G} \text{ such that } \mathcal{F}[A\bar{g}_A] = 0 \quad (14.46)$$

For example, in nonabelian gauge theory one often takes $\mathcal{F}[A] = \partial_\mu A^\mu$, which fixes the gauge, once suitable boundary conditions are imposed.

Let us consider the trivial V bundle over the gauge group

$$E = \mathcal{G} \times V \quad (14.47)$$

For any $A \in \mathcal{A}$ we can define a section of this bundle:

$$s_A: g \mapsto s_A(g) = (g, \mathcal{F}[A^g]) \quad (14.48)$$

Since \mathcal{F} defines a good slice, this section will have a unique zero. Hence, if $\eta[\mathcal{Z}(s_A) \hookrightarrow \mathcal{G}]$ is the Poincaré dual to the zero section, we have:

$$\int_{\mathcal{G}} \eta[\mathcal{Z}(s_A) \hookrightarrow \mathcal{G}] = 1 \quad (14.49)$$

⁴¹ There are topological obstructions to choosing global sections of \mathcal{A} associated with the ‘‘Gribov ambiguity’’ [196]. These do not affect our calculations since we are constructing a local measure.

We will now rewrite this formula using the MQ formalism. We will choose a metric $(\cdot, \cdot)_V$ and the trivial connection on E in order to construct the MQ representative of the Thom class $\Phi(E)$ in the standard way:

$$\Phi(E) = \left(\frac{1}{2\pi}\right)^{\dim V} \int_{\widehat{V}^*} d\bar{c}d\bar{\pi} \exp [Q(\Psi_{\text{g.f.}})] \quad (14.50)$$

where $Q = d_E + \delta$ is the sum of the exterior derivatives on E and V :

$$\begin{aligned} \delta\bar{c}_a &= \bar{\pi}_a \\ \delta\bar{\pi}_a &= 0 \end{aligned} \quad (14.51)$$

And, in the standard way:

$$\begin{aligned} Q\Psi_{\text{g.f.}} &= Q(-i\langle\bar{c}, x\rangle - (\bar{c}, \bar{\pi})_{V^*}) \\ &= -i\langle\bar{\pi}, x\rangle + i\langle\bar{c}, d_E x\rangle - (\bar{\pi}, \bar{\pi})_{V^*} \end{aligned} \quad (14.52)$$

where x is a fiber coordinate.

The pullback, $s_A^*(\Phi)$, defines a top-form on the group \mathcal{G} . Using the basic tautology (11.32):

$$\widehat{\mathcal{F}}(\mathcal{G}) \quad \longleftrightarrow \quad \Omega^\bullet(\mathcal{G}) \quad (14.53)$$

we may write instead:

$$s_A^*(\Phi(E \rightarrow \mathcal{G})) = \left(\frac{1}{2\pi}\right)^{\dim V} \int_{\widehat{V}^*} d\bar{c}d\bar{\pi} \exp\left(Q[\langle\bar{c}, \mathcal{F}[A^g]\rangle - (\bar{c}, \bar{\pi})_{V^*}]\right) \quad (14.54)$$

where now $Q = Q_{\mathcal{G}} + \delta$, and $Q_{\mathcal{G}}$, the DeRham differential reads, under the correspondence (14.53):

$$\begin{aligned} c &\longleftrightarrow g^{-1}dg \\ Qg &= gc \\ Qg^{-1} &= -cg^{-1} \end{aligned} \quad (14.55)$$

The standard superspace measure (11.33) is $\hat{\mu}_{\mathcal{G}} = \mu_H(g)dc$. Thus equation (14.49) can be written

$$1 = \int dc \mu_H(g) \widehat{\eta}[\mathcal{Z}(s_A) \hookrightarrow \mathcal{G}] = \int_{\mathcal{G}} \mu_H(g) \int dcd\bar{c}d\bar{\pi} e^{Q\Psi_{\text{g.f.}}} \quad (14.56)$$

We now - following the standard derivation - insert “1” into the path integral over gauge fields:

$$\begin{aligned} Z &\equiv \int_{\mathcal{A}} dAe^{-I_{\text{Y.M.}}[A]} \\ &= \int_{\mathcal{A}} dAe^{-I_{\text{Y.M.}}[A]} \int_{\mathcal{G}} \mu_H(g) \int dcd\bar{c}d\bar{\pi} \exp\left(Q[\langle\bar{c}, \mathcal{F}[A^g]\rangle - (\bar{c}, \bar{\pi})_{V^*}]\right) \end{aligned} \quad (14.57)$$

Now, we would like to change variables $A \rightarrow A^g$ and factor out the A -independent Haar measure, but there is one important conceptual point we must first address. If we simply set $A \rightarrow A^g$ then Q , as defined, would not act on \mathcal{F} : making the change of variables in the argument of Q is wrong. However, one easily checks that

$$QA^g = -d_x c - [A^g, c]_+ \quad (14.58)$$

That is, the action of Q coincides with the differential of Lie algebra cohomology.: $Q_{\text{L.A.}}A = -D_A c$. Thus, we can rewrite the RHS of (14.57) as:

$$\int_{\mathcal{G}} \mu_H(g) \int_{\mathcal{A}} dA^g e^{-I_{\text{Y.M.}}[A^g]} \int dcd\bar{c}d\bar{\pi} \exp\left(\tilde{Q}[\langle \bar{c}, \mathcal{F}[A^g] \rangle - (\bar{c}, \bar{\pi})_{V^*}]\right) \quad (14.59)$$

where \tilde{Q} is now expressed in terms of Lie algebra cohomology:

$$\tilde{Q} = Q_{\text{L.A.}} + \delta \quad (14.60)$$

and hence, with $\tilde{\Psi}_{\text{g.f.}} = \langle \bar{c}, \mathcal{F}[A] \rangle - (\bar{c}, \bar{\pi})_{V^*}$ we have

$$\boxed{\frac{1}{\text{vol}\mathcal{G}} \int_{\mathcal{A}} dA e^{-I_{\text{Y.M.}}} = \int dAdcd\bar{c}d\bar{\pi} e^{-I_{\text{Y.M.}} + \tilde{Q}(\tilde{\Psi}_{\text{g.f.}})}} \quad (14.61)$$

Remarks:

1. In standard treatments of perturbative Yang-Mills theory, with the choice $\mathcal{F} = \partial \cdot A$, the overall scale of the metric $(\cdot, \cdot)_V$ is the parameter ξ of “ R_ξ -gauge.” The ξ -independence of correlators of gauge-invariant observables is conceptually the same as topological invariance.
2. It is interesting to compare the actions from the FP procedure with the projection form $\Phi(P \rightarrow M)$. When constructing the latter we make no choice of gauge fixing term, nor do we choose a slice for the gauge orbit. In the FP procedure we have an integral over two odd fields \bar{c} and c (and one even field $\bar{\pi}$, if we introduce the Lagrange multiplier). In the projection form we integrate over two even fields λ and ϕ and one odd field η .
3. A simple extension of the above argument shows that if there are other fields in the theory, transforming in representations of the gauge group then \tilde{Q} becomes the differential for Lie algebra cohomology in the representation defined by those fields.
4. When there are other fields in the theory, it can happen that the last innocent-looking step $dA^g d\psi^g = dAd\psi$ is wrong. This is the phenomenon of anomalies.
5. If \mathcal{G} does not act freely then there is an extra factor on the RHS of (14.61) of the volume of the subgroup that fixes \mathcal{A} . This factor is important in comparing YM_2 to topological results [226].

14.6. The general construction of cohomological field theory.

We now summarize what we have learned in chapters 10,11,14.

14.6.1. Fields

We introduce fields with ghost numbers

$$\begin{array}{ll}
A, \psi & U = 0, 1 \\
\rho, \pi & U = -1, 0 \\
\lambda_a, \eta_a & U = -2, -1 \\
\bar{c}, \bar{\pi} & U = -1, 0 \\
\phi^a, c^a & U = 2, 1.
\end{array} \tag{14.62}$$

These should be interpreted as generating the DeRham complex of the total space of a certain vector bundle $\mathcal{E} \rightarrow \mathcal{C}$ over field space which is a sum of three factors:

$$\mathcal{E} = \Pi\mathcal{E}_{\text{loc}} \oplus \mathcal{E}_{\text{proj}} \oplus \Pi\mathcal{E}_{\text{g.f.}} \tag{14.63}$$

The first line in (14.62) gives the DeRham complex of the base. The next three lines give the DeRham complex of the three kinds of fibers. Thus we may regard $\psi = \tilde{d}A$, $\pi = \tilde{d}\rho$, $\eta = \tilde{d}\lambda$ and $\bar{\pi} = \tilde{d}\bar{c}$. The last line generates the Weil complex. The commutation properties are dictated by the total grading (form degree plus ghost number): all fields with odd total grading are anti-commuting; those with even total grading are commuting.

14.6.2. Observables

The observables and action are formulated using the ‘‘BRST model’’ of \mathcal{G} -equivariant cohomology described in section 10.8 [166,114,180]. Recall that to any Lie algebra, \mathfrak{g} , there is an associated differential graded Lie algebra (DGLA) $\underline{\mathfrak{g}}[\theta] \equiv \underline{\mathfrak{g}} \otimes \Lambda^\bullet\theta$; $\theta^2 = 0$, $\deg \theta = -1$, $\deg \underline{\mathfrak{g}} = 0$ and $\partial\theta = 1$. Moreover, if M is a superspace with a $\underline{\mathfrak{g}}$ -action then $\Omega^\bullet(M)$ is a differential graded $\underline{\mathfrak{g}}[\theta]$ module, with $X \in \underline{\mathfrak{g}} \rightarrow \mathcal{L}_X$ and $X \otimes \theta \rightarrow \iota_X$. In our case $\underline{\mathfrak{g}} \rightarrow \text{Lie } \mathcal{G}$ and M is the total space of \mathcal{E} . The BRST complex is $\hat{\mathcal{E}} \equiv \Lambda^\bullet\Sigma(\text{Lie } \mathcal{G}[\theta])^* \otimes \Omega^\bullet(\mathcal{E})$ where Σ is the suspension, increasing grading by 1. The differential on the complex is $Q = (d_{\mathcal{E}} + \partial^*) + Q_{\text{L.A.}}$ where ∂^* is dual to ∂ and $Q_{\text{L.A.}}$ is the BRST differential for the DGLA $\text{Lie } \mathcal{G}[\theta]$ acting on $\Omega^\bullet(\mathcal{E})$. Physical observables $\hat{\mathcal{O}}_i$ are Q -cohomology classes of the ‘‘basic’’ (Lie \mathcal{G} -relative) subcomplex and correspond to basic forms $\mathcal{O}_i \in \Omega^\bullet(\mathcal{C})$ which descend and restrict to cohomology classes $\omega_i \in H^\bullet(\mathcal{M})$.

14.6.3. Action

The basic data needed to construct the action are:

1. \mathcal{G} -invariant metrics on \mathcal{C} and \mathcal{E} .
2. A \mathcal{G} -equivariant section $s : \mathcal{C} \rightarrow \mathcal{E}_{\text{loc}}$, and a \mathcal{G} -equivariant connection $\nabla s = ds + \theta s \in \Omega^1(\mathcal{C}; \mathcal{E}_{\text{loc}})$.
3. A \mathcal{G} -nonequivariant section $\mathcal{F} : \mathcal{C} \rightarrow \mathcal{E}_{\text{g.f.}}$, whose zeros determine local cross-sections for $\mathcal{C} \rightarrow \mathcal{C}/\mathcal{G}$.

The action is then $I = Q\Psi$ where

$$\begin{aligned}
 \Psi &= \Psi_{\text{localization}} + \Psi_{\text{projection}} + \Psi_{\text{gauge fixing}} \\
 \Psi_{\text{loc}} &= -i\langle \rho, s \rangle - (\rho, \theta \cdot \rho)_{\mathcal{E}_{\text{localisation}}^*} + (\rho, \pi)_{\mathcal{E}_{\text{localisation}}^*} \\
 \Psi_{\text{proj}} &= i(\lambda, C^\dagger)_{\text{Lie } \mathcal{G}} \\
 \Psi_{\text{gauge fixing}} &= \langle \bar{c}, \mathcal{F}[A] \rangle - (\bar{c}, \bar{\pi})_{\mathcal{E}_{\text{g.f.}}}
 \end{aligned} \tag{14.64}$$

14.6.4. Correlators

Correlation functions are intersection numbers according to the localization formula:

$$\boxed{\int_{\mathcal{E} \times \widehat{\text{Lie } \mathcal{G}}} \hat{\mu} e^{-I} \hat{\mathcal{O}}_1 \cdots \hat{\mathcal{O}}_k = \int_{\mathcal{Z}(s)/\mathcal{G}} \omega_1 \wedge \cdots \wedge \omega_k \chi(\text{cok } \mathbb{O}/\mathcal{G})} \tag{14.65}$$

where \mathbb{O} is the operator defined in (14.44).

15. Topological Yang-Mills Theory

15.1. Basic Data

The data are:

- a Riemannian spacetime, M , with metric, $g_{\mu\nu}$, of Euclidean signature.
- a compact finite dimensional Lie group, G .
- a principal G -bundle, $P \rightarrow M$.
- the group, \mathcal{G} , of gauge transformations for P . (In the case where P is the trivial bundle, $P = M \times G$, this is just $\mathcal{G} = \text{MAP}(M, G)$.)
- the space \mathcal{A} of connections on P .

In analogy to the case of SQM and the topological sigma model we have

$$T_A \mathcal{A} = \Omega^1(M; \underline{\mathfrak{g}}) \quad . \quad (15.1)$$

Indeed, \mathcal{A} is an affine space, and the difference of two connections lies in $\Omega^1(M; \underline{\mathfrak{g}})$. The Lie algebra of the group of gauge transformations is $Lie(\mathcal{G}) = \Omega^0(M; \underline{\mathfrak{g}})$.

The spaces $\Omega^k(M; \underline{\mathfrak{g}})$ all inherit metrics:

$$(a, b) = \int_M \text{Tr}(a \wedge *b) \quad (15.2)$$

where $*$ is the Hodge- $*$ operation. The trace Tr is in the fundamental representation of $SU(N)$ ⁴².

15.2. Equations

We will take the $D = 4$ Donaldson theory as an example and indicate the generalization to other TYM theories below. In $D = 4$, $*$: $\Omega^2(M) \rightarrow \Omega^2(M)$ and $*^2 = 1|_{\Omega^2(M)}$, so that we may define the eigenspaces $\Omega^{2,+}(M)$ and $\Omega^{2,-}(M)$ with eigenvalues under $*$ of $+1$ and -1 , respectively:

$$\Omega^2(M) = \Omega^{2,-}(M) \oplus \Omega^{2,+}(M)$$

Note that the $*$ -operator on the degree two forms depends only on the conformal class of the Riemannian metric. Conversely the subspaces $\Omega^{2,+}(M)$ define a conformal structure on M .

The anti-self-dual (ASD) Yang-Mills connections satisfy:

$$F + *F = 0 \quad (15.3)$$

The solution space $\mathcal{A}_+ \subset \mathcal{A}$ admits a \mathcal{G} -action and we wish to localize to $\mathcal{M}_+ = \mathcal{A}_+/\mathcal{G}$.

⁴² In general we follow the normalization of [226] so that $-\frac{1}{8\pi^2} \text{Tr} F^2$ generates $H^4(B\tilde{G}; \mathbb{Z})$, where \tilde{G} is the universal cover of G .

15.3. Vector Bundles

We choose

$$\mathcal{V}_+ = \mathcal{A} \times \Omega^{2,+}(M, \underline{\mathfrak{g}}) \quad (15.4)$$

which has section $s(A) = F + *F$. The fibers have an action of the gauge group \mathcal{G} , so we may form the vector bundle

$$\mathcal{E}_+ = \mathcal{A} \times_{\mathcal{G}} \Omega^{2,+}(M, \underline{\mathfrak{g}}) \quad (15.5)$$

associated to the principal bundle $\mathcal{A} \rightarrow \mathcal{A}/\mathcal{G}$. Since $s(A)$ transforms equivariantly it defines a section \bar{s} of \mathcal{E}_+ . We have

$$\mathcal{Z}(s)/\mathcal{G} = \mathcal{Z}(\bar{s})$$

so we are in the situation of 14.1.

15.4. Connection on \mathcal{V}_+ and \mathcal{E}_+

\mathcal{V}_+ is trivial when viewed as a bundle over \mathcal{A} , so we can choose the trivial connection for ∇_s in (14.33). On the other hand, \mathcal{E}_+ has a nontrivial connection. Since \mathcal{A} has a \mathcal{G} -invariant metric, it inherits a connection ∇ from the natural connection defined in section 14.3.2 above. The operator C becomes, in this case, $C: \Omega^0(M, \underline{\mathfrak{g}}) \rightarrow T_A\mathcal{A}$ defined by

$$C\epsilon = D_A\epsilon = d\epsilon + [A, \epsilon] \in \Omega^1(M; \underline{\mathfrak{g}})$$

The image of C defines the vertical tangent space. Therefore, the horizontal subspace of $T_A\mathcal{A}$ is orthogonal to the gauge orbit and therefore horizontal tangent vectors $\tau \in \Omega^1(M, \underline{\mathfrak{g}})$ satisfy:

$$\begin{aligned} D_A^*\tau &= (D_A^\mu\tau_\mu) \\ &= g^{\mu\nu}(\partial_\nu\tau_\mu + [A_\nu, \tau_\mu] + \Gamma_{\nu\mu}^\lambda\tau_\lambda) = 0 \end{aligned} \quad (15.6)$$

where $\Gamma_{\mu\nu}^\lambda$ is the Levi-Civita connection on M associated to $g_{\mu\nu}$.

To be explicit, if $\tau \in T_A\mathcal{A}$ is a tangent vector, so $\tau \in \Omega^1(M; \underline{\mathfrak{g}})$, then the connection evaluated on τ is given by (14.16):

$$\frac{1}{D^\dagger D} D^\dagger\tau = \int_M \sqrt{g} d^4y G(x, y)_b^a (D^\mu\tau_\mu)^b(y) \in \Omega^0(M; \underline{\mathfrak{g}}) \quad (15.7)$$

where $G(x, y)_b^a$ is the Green function of the Laplacian $D^\dagger D: \Omega^0(M, \underline{\mathfrak{g}}) \rightarrow \Omega^0(M, \underline{\mathfrak{g}})$. Since this expression involves $1/D^\dagger D$, it is manifestly non-local in spacetime.

15.5. BRST Complex

The BRST complex of fields is a superspace realization of a complex for computing the \mathcal{G} -equivariant cohomology of \mathcal{A} tensored with a \mathcal{G} -module. The differential forms $\Omega^\bullet(\mathcal{A})$ are represented by functions on superspace: $\hat{\mathcal{F}}(\mathcal{A})$ generated by⁴³

$$A_\mu^a(x) \in \Omega^0(\mathcal{A}) \quad \psi_\mu^a(x) \leftrightarrow \tilde{d}A_\mu^a(x) \in \Omega^1(\mathcal{A}) \quad (15.8)$$

of ghost numbers 0 and 1, respectively. The remaining fields and transformation properties depend on what model we use for \mathcal{G} -equivariant cohomology of \mathcal{A} .

15.5.1. Weil Algebra

The Weil algebra is constructed from the dual of the algebra of gauge transformations $\text{Lie } \mathcal{G}^* \cong \Omega^4(M; \underline{\mathfrak{g}})$. We define c and $\phi \in \Omega^0(M; \underline{\mathfrak{g}})$ which can be expanded:

$$c = c^a(x)T_a \in \Omega^0(M; \underline{\mathfrak{g}})$$

$$\phi = \phi^a(x)T_a \in \Omega^0(M; \underline{\mathfrak{g}})$$

The coordinate functions $c^a(x)$ or $\phi^a(x)$ on the Lie algebra of \mathcal{G} can be taken as generators of the dual Lie algebra, $\text{Lie } \mathcal{G}^*$ (corresponding to δ -function supported measures in $\Omega^4(M; \underline{\mathfrak{g}})$). These are the analogs of θ^i and ϕ^i in the general Weil algebra discussed in chapter 10, section 10.3. As always $c^a(x)$ and $\phi^a(x)$ have grading (ghost number) 1 and 2, respectively.

15.5.2. BRST Model

According to chapter 10 we should take the complex:

$$\mathcal{W}(\text{Lie } \mathcal{G}) \otimes \Omega^\bullet(\mathcal{A})$$

using the “BRST” differential of 10.5.2. The generators of the complex are A, ψ, c and ϕ as above. Translating (10.19) into the present example we find:

$$\begin{aligned} d_B A &= \psi - D_A c \\ d_B \psi &= [\psi, c] - D_A \phi \\ d_B c &= \phi - \frac{1}{2}[c, c] \\ d_B \phi &= -[c, \phi] \end{aligned} \quad (15.9)$$

Exercise.

Show how the above transformations can be considered as BRST transformations plus a “supersymmetry” transformation, as in 10.8.

⁴³ Strictly speaking, A should be evaluated at a point $p \in P$, since $A \in \Omega^1(P; \underline{\mathfrak{g}})$.

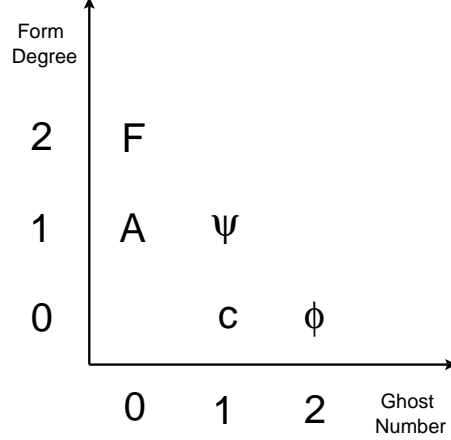

Fig. 36: Assembling fields according to ghost number and form degree.

The equations defining the BRST model of \mathcal{G} -equivariant cohomology of \mathcal{A} were given a very elegant formulation by Baulieu and Singer [23]. Let us consider, formally, the sums

$$\begin{aligned}\mathbf{A} &= A + c \\ \mathbb{F} &= F + \psi + \phi\end{aligned}\tag{15.10}$$

These linear combinations are homogeneous in the total grading: ghost number plus form degree (see fig. 36).

One defines the differential $d + d_B$ of total degree 1. The relations of the Weil algebra

$$\begin{aligned}(d + d_B)\mathbf{A} &= \mathbb{F} - \frac{1}{2}[\mathbf{A}, \mathbf{A}] \\ (d + d_B)\mathbb{F} &= [\mathbf{A}, \mathbb{F}]\end{aligned}\tag{15.11}$$

are equivalent to equation (15.9), the Bianchi identity, and the equation for the curvature.

15.5.3. Cartan Model

This is the model originally used in [218]. Generators of the complex $S(\underline{\mathfrak{g}}^*) \otimes \Omega^\bullet(\mathcal{A})$ are A , ψ and ϕ . Translating (10.16) into the present example, we find:

$$\begin{aligned}d_{\mathcal{C}}A &= \psi \\ d_{\mathcal{C}}\psi &= -D_A\phi \\ d_{\mathcal{C}}\phi &= 0\end{aligned}\tag{15.12}$$

Thus, $d_{\mathcal{C}}^2$ is a gauge transformation by ϕ , and thus as expected vanishes on gauge invariant operators, i.e. the \mathcal{G} -invariant subcomplex.

15.5.4. Antighosts

The antighosts for the construction of $\Phi_{\text{localization}}(\mathcal{A} \rightarrow \mathcal{A}_+)$ are

$$\begin{aligned}\rho &\longrightarrow \chi_{\alpha\beta} \in \Omega^{2,+}(M, \underline{\mathfrak{g}}) \\ \pi &\longrightarrow H_{\alpha\beta} \in \Omega^{2,+}(M, \underline{\mathfrak{g}})\end{aligned}\tag{15.13}$$

These have ghost numbers -1 and 0 , respectively. The antighosts for the construction of $\Phi_{\text{projection}}(\mathcal{A} \rightarrow \mathcal{A}/\mathcal{G})$ are:

$$\begin{aligned}\lambda &\longrightarrow \lambda^a \in \Omega^0(M, \underline{\mathfrak{g}}) \\ \eta &\longrightarrow \eta^a \in \Omega^0(M, \underline{\mathfrak{g}})\end{aligned}\tag{15.14}$$

of ghost numbers -2 and -1 .

Finally, for gauge fixing we choose antighosts

$$\begin{aligned}\bar{c} &\in \Omega^0(M, V^*) \\ \bar{\pi} &\in \Omega^0(M, V^*)\end{aligned}\tag{15.15}$$

of ghost numbers -1 and 0 as is standard in FP gauge fixing. Here V is the vector space in which the noninvariant function $\mathcal{F}[A]$ of section 14.5 takes values.

The action of $Q_{\mathcal{C}}$ is that described in previous chapters

$$\begin{aligned}Q_{\mathcal{C}} \begin{pmatrix} \chi \\ H \end{pmatrix} &= \begin{pmatrix} 0 & 1 \\ -\mathcal{L}_\phi & 0 \end{pmatrix} \begin{pmatrix} \chi \\ H \end{pmatrix} = \begin{pmatrix} H \\ -[\phi, \chi] \end{pmatrix} \\ Q_{\mathcal{C}} \begin{pmatrix} \lambda \\ \eta \end{pmatrix} &= \begin{pmatrix} 0 & 1 \\ -\mathcal{L}_\phi & 0 \end{pmatrix} \begin{pmatrix} \lambda \\ \eta \end{pmatrix} = \begin{pmatrix} \eta \\ -[\phi, \lambda] \end{pmatrix} \\ Q_{\mathcal{C}} \begin{pmatrix} \bar{c} \\ \bar{\pi} \end{pmatrix} &= \begin{pmatrix} 0 & 1 \\ -\mathcal{L}_\phi & 0 \end{pmatrix} \begin{pmatrix} \bar{c} \\ \bar{\pi} \end{pmatrix} = \begin{pmatrix} \bar{\pi} \\ -\phi \cdot \bar{c} \end{pmatrix}\end{aligned}\tag{15.16}$$

15.6. Lagrangian

15.6.1. Localization Lagrangian

The Cartan representation of the MQ form in (11.23) becomes :

$$\Psi_{\text{Localization}} = \frac{1}{e^2} \int_M d^4x \sqrt{g} \text{Tr} \chi (iF_+ - tH)\tag{15.17}$$

and

$$Q_{\mathcal{C}} \Psi_{\text{Localization}} = \frac{1}{e^2} \int d^4x \sqrt{g} \{ \text{Tr} H (iF_+ - tH) - \text{Tr} \chi (i(D_A \psi)_+ + t[\phi, \chi]) \}.\tag{15.18}$$

Integrating out H gives

$$H = \frac{i}{2t} F_+. \quad (15.19)$$

yielding the Lagrangian:

$$\frac{1}{e^2} \int d^4x \sqrt{g} \left\{ -\frac{1}{4t} \text{Tr} F_+^2 - i \text{Tr} \chi^{\mu\nu} (D_A \psi)_{\mu\nu}^+ + t \chi_{\mu\nu} [\phi, \chi]^{\mu\nu} \right\}. \quad (15.20)$$

As we remarked in section 14.4 there is no need for an explicit projection on the horizontal components of this form since all of the vertical directions on \mathcal{A} are taken up by the projection part of the path integral.

15.6.2. Projection Lagrangian

We now apply (14.22) to the present case. C^\dagger is a one-form with values in the Lie algebra $Lie(\mathcal{G})$. From (15.6) we see that it may be identified with

$$C^\dagger \longrightarrow - * D_A * \psi = -(D^\mu \psi_\mu)^a \in \Omega^1(\mathcal{A}; Lie(\mathcal{G})) \quad (15.21)$$

so that:

$$\begin{aligned} \Psi_{\text{Projection}} &= -\frac{i}{e^2} (\lambda, C^\dagger) = \frac{i}{e^2} \int_M \text{Tr} \lambda D_A * \psi \\ &= -\frac{i}{e^2} \int_M d^4x \sqrt{g} \text{Tr} \left(\lambda * D_A * \psi \right) \end{aligned} \quad (15.22)$$

and hence

$$Q_C \Psi_{\text{Projection}} = -\frac{i}{e^2} \int_M \text{Tr} \left(\eta D_A * \psi + \lambda \{ \psi, * \psi \} + \lambda D_A * D_A \phi \right) \quad (15.23)$$

corresponding to the three terms in (14.23).

Combining the actions for projection and localization we recover Witten's celebrated Lagrangian[218] for Donaldson theory[65,66,67]:

$$\begin{aligned} I_{\text{Donaldson}} &= \frac{1}{e^2} \int d^4x \sqrt{g} \left[i \text{Tr} \left(\eta D_A^\mu \psi_\mu + \lambda \{ \psi_\mu, \psi^\mu \} + \lambda D_A * D_A \phi \right) \right. \\ &\quad \left. + \left(-\frac{1}{4t} \text{Tr} F_+^2 - \text{Tr} \chi_{\mu\nu} [i(D_A \psi)_+^{\mu\nu} + t[\phi, \chi^{\mu\nu}]] \right) \right] \end{aligned} \quad (15.24)$$

15.6.3. Gauge-Fixing Lagrangian

The Donaldson Lagrangian of [218] is gauge invariant. Therefore, if one were to attempt to evaluate it with standard methods of local quantum field theory the Lagrangian

would have to be gauge-fixed, as emphasized by Baulieu and Singer [23]. As discussed in 14.5 this can be done by adding the action:

$$\Psi_{\text{gauge fixing}} = \int_M d^4x \sqrt{g} \text{Tr } \bar{c} (\mathcal{F}[A] - \xi \bar{\pi}) \quad (15.25)$$

where $\mathcal{F}[A]$ is gauge noninvariant, and we have chosen $V = \underline{\mathfrak{g}}$, for simplicity. ξ is an arbitrary (bosonic) constant gauge-fixing parameter.

15.6.4. MQ form on $\mathcal{E}_+ \rightarrow \mathcal{M}$

We have been writing forms “upstairs” on \mathcal{A} . It is nice to see how integrating out various fields⁴⁴ produces the standard MQ formula for a section \bar{s} of \mathcal{E}_+ . Of course, the resulting Lagrangian is no longer local.

Integrating out λ produces

$$\phi = -\frac{1}{D_A^\dagger D_A} * \{\psi, *\psi\} \quad (15.26)$$

in accord with the identification of ϕ with the curvature of \mathcal{E}_+ .

Integrating out η enforces

$$D_A^\mu \psi_\mu = 0$$

and (15.6) shows that this means ψ is horizontal : $\langle D\epsilon, \psi \rangle = 0$. The connection on the section ∇s in the MQ formula is very simple on \mathcal{A} , since the connection on \mathcal{V}_+ is trivial:

$$\nabla s = \tilde{d}s = (D\psi)_+$$

where $(\)_+$ denotes projection onto the self-dual part. For horizontal ψ this descends to the same expression on \mathcal{A}/\mathcal{G} . Substituting back (15.26) we get the Lagrangian:

$$I = \frac{1}{e^2} \int d^4x \text{Tr} \left(-\frac{1}{4t} F_+^2 + i \chi_{\mu\nu} (D_A \psi)_+^{\mu\nu} - t [\chi, \chi] \frac{1}{D^\dagger D} [\psi_\mu, \psi^\mu] \right) \quad (15.27)$$

which coincides with the form (11.30) interpreted as a form on \mathcal{E}_+ .

⁴⁴ This discussion is subject to difficulties related to reducible connections.

15.7. $D = 2$: Flat Connections

Another possible moduli space is the space of flat connections [34]. The deformation complex which is relevant to this case is the following

$$0 \longrightarrow \Omega^0(M, \underline{\mathfrak{g}}) \xrightarrow{D_A^{(0)}} \Omega^1(M, \underline{\mathfrak{g}}) \xrightarrow{D_A^{(1)}} \Omega^2(M, \underline{\mathfrak{g}}) \xrightarrow{D_A^{(2)}} \dots \xrightarrow{D_A^{(\dim M)}} \Omega^{\dim M}(M, \underline{\mathfrak{g}}) \longrightarrow 0 \quad (15.28)$$

The tangent space is given by the first cohomology of this complex. We recognize this as the twisted deRham complex, whose index, in the case of flat connections, is just

$$\begin{aligned} \text{ind } D_A &= \sum_{i=0}^{\dim G} (-1)^i h_i \\ &= \dim G \chi(M) \end{aligned} \quad (15.29)$$

The case of two dimensions is particularly interesting. In the case of a Riemann surface of genus $g \geq 2$, one finds the dimension of the moduli space to be

$$\begin{aligned} \dim \mathcal{M}(M, G) &= 2h_0 - \dim G \chi(M) \\ &= 2h_0 + 2(g-1)\dim G \end{aligned} \quad (15.30)$$

For irreducible connections, $h_0 = 0$, so that $\dim \mathcal{M}(M, G) = 2 \dim G(g-1)$, in accord with section 3.6.1. Reducible connections increase the dimension of the moduli space.

For $d = 4$, we have

$$h_1 = h_0 + \frac{1}{2} (h_2 - \dim G) \chi(M)$$

For irreducible connections $h_0 = 0$. In the case that both h_0 and h_2 vanish, non-trivial moduli spaces exist only for manifolds with $\chi(M) < 0$. However, moduli spaces of *reducible* connections can continue to be non-trivial, even if $\chi(M) > 0$.

To define a topological field theory that studies the moduli space of flat connections in $d = 2$, we choose following section of $\mathcal{E}_0 = \mathcal{A} \times_{\mathcal{G}} V$ with $V = \Omega^2(M; \underline{\mathfrak{g}})$:

$$s(A) = F$$

The only point that changes from our discussion above is that now χ and $H \in \mathcal{E}_0^*$ lie in $\Omega^0(M; \underline{\mathfrak{g}})$. All other manipulations leading to the Lagrangian are identical. Thus we simply set $\chi_{\mu\nu} = \epsilon_{\mu\nu} \chi$ in the above Lagrangian. The theory localizes to the space $\mathcal{M}_0(\Sigma)$ of *flat* connections on a surface Σ .

15.8. Observables

The observables, i.e. the BRST cohomology of the complex described in section 15.5 above, are quantum field theory representatives of certain cohomology classes as we shall now describe. Mathematically, these can be obtained by a “universal” construction analogous to that used for topological sigma models.

15.8.1. The Big Bundle

Consider the product space $\mathcal{A} \times P$. Naively it seems we could regard this as a $\mathcal{G} \times G$ bundle over a base space, $\mathcal{A}/\mathcal{G} \times M$. However, there are difficulties which ensue from the fact that the action of \mathcal{G} on \mathcal{A} is not free *even* at points $A \in \mathcal{A}$ where the connection is irreducible. The stabilizer, Γ_A , contains at least the center of the group, $C(G)$. For this reason (and others) mathematicians work with *framed connections* (See, for example, [67].)

Let (M, m_0) be a four manifold with base point $m_0 \in M$. Then a framed connection is a pair (A, φ) where A is a connection and $\varphi: G \rightarrow P_{m_0}$ is an isomorphism from the gauge group into the fibre over m_0 . The gauge group acts naturally (and without fixed points) on (irreducible) framed connections. So consider

$$\tilde{\mathcal{B}} = (\mathcal{A} \times \text{Hom}(G, P_{m_0}))/\mathcal{G}$$

There is a natural map which forgets the framing

$$\beta: \tilde{\mathcal{B}} \longrightarrow \mathcal{B} = \mathcal{A}/\mathcal{G}$$

Equivalently we may think of the framed connections as the quotient

$$\tilde{\mathcal{B}} = \mathcal{A}/\mathcal{G}_0$$

where $\mathcal{G}_0 = \{g \in \mathcal{G} \mid g(m_0) = 1\}$. The “forgetful” map, β , takes the quotient with the remainder of the gauge group: $\mathcal{G}/\mathcal{G}_0 \equiv \text{Aut}(P_{m_0}) \equiv G$. The inverse image under β of $[A] \in \mathcal{A}/\mathcal{G}$ is isomorphic to G/Γ_A .

Finally if $\tilde{\mathcal{B}}^* \subset \tilde{\mathcal{B}}$ is the space of framed irreducible connections, then

$$\beta: \tilde{\mathcal{B}}^* \longrightarrow \mathcal{B}^*$$

is a principal $G_0 = G/C(G)$ bundle, called the *base point* fibration.

Next we introduce the universal family of connections parametrized by $\tilde{\mathcal{B}}^*$.

$$\begin{array}{ccc}
 & \mathcal{A}^* \times P & \\
 \swarrow \mathcal{G}_0 & & \searrow \mathcal{G}_0 \\
 \tilde{\mathcal{B}}^* \times P & & \mathcal{A}^* \times M \\
 \searrow \mathcal{G}_0 & & \swarrow \mathcal{G}_0 \\
 & \tilde{\mathcal{B}}^* \times M &
 \end{array}$$

It is apparent that

$$\begin{array}{c}
 \tilde{\mathcal{B}}^* \times P \leftarrow G_0 \\
 \downarrow \\
 \tilde{\mathcal{B}}^* \times M
 \end{array}$$

is a principal G_0 -bundle and as such has a classifying map

$$\Phi: \tilde{\mathcal{B}}^* \times M \longrightarrow BG_0$$

So we obtain characteristic classes via pullback

$$c_r(\tilde{\mathcal{B}}^* \times M) = \Phi^*(c_r(BG_0)) \in H^{2r}(\tilde{\mathcal{B}}^* \times M)$$

or more generally

$$\prod_{i=1}^n c_r(\tilde{\mathcal{B}}^* \times M)^{d_i} = \Phi^*\left(\prod_{i=1}^n c_r(BG_0)^{d_i}\right) \in H^s(\tilde{\mathcal{B}}^* \times M)$$

where $s = 2 \sum_{i=1}^n r_i d_i$.

To construct observables in topological Yang-Mills theories (= cohomology classes on $\tilde{\mathcal{B}}^*$) one defines the slant product pairing. For $c \in H^d(\tilde{\mathcal{B}}^* \times M)$ and $[\alpha] \in H_i(M)$,

$$\begin{aligned}
 /: H^d(\tilde{\mathcal{B}}^* \times M) \times H_i(M) &\longrightarrow H^{d-i}(\tilde{\mathcal{B}}^*) \\
 c/[\alpha] &= \int_{\alpha} c
 \end{aligned}$$

We shall refer to the associated map on $H_{\bullet}(M)$ as the *Donaldson map*.

For the case of $G = SU(2)$, $c = c_2(BG_0)$ and $\Sigma \in H_2(M)$, this construction yields:

$$\begin{aligned}
 \mu: H_2(M) &\longrightarrow H^2(\tilde{\mathcal{B}}^*) \\
 \mu[\Sigma] &= \int_{\Sigma} [\Phi^*(c_2(BG_0))]_{(2,2)}
 \end{aligned} \tag{15.31}$$

where $[\cdots]_{(p,q)}$ is the projection of \cdots to the form degree (p, q) part on $\tilde{\mathcal{B}}^* \times M$.

If M is connected and simply-connected, then the only non-trivial homology groups are $H_0(M)$, $H_2(M)$, and $H_4(M)$. We may then consider the following cohomology classes on $\tilde{\mathcal{B}}^*$:

1. By Poincaré duality $h^4 = h^0 = 1$ for connected M . In this case the slant product is equivalent to the pushdown via the projection operator

$$\pi_1: \tilde{\mathcal{B}}^* \times M \longrightarrow \tilde{\mathcal{B}}^*$$

We may take any characteristic class (of degree ≥ 4) and integrate it over M :

$$(\pi_1)_* \Phi^*: H^d(BG_0) \times H_4(M) \longrightarrow H^{d-4}(\tilde{\mathcal{B}}^*) \quad (15.32)$$

2. If $h^2 \neq 0$, then given a basis $\{[\Sigma_i]\}_{i=1, \dots, h^2}$ of $H_2(M)$ and a characteristic class $c(\tilde{\mathbf{P}}) \in H^d(\tilde{\mathbf{P}}, \mathbf{Z})$ we may construct the observables

$$\mu_c([\Sigma_i]) = \int_{\Sigma_i} \left[\Phi^*(c(\tilde{\mathbf{P}})) \right]_{(d-2, 2)}$$

3. $h^0 = 1$ for connected M . Then we may evaluate the 0-form part of any characteristic class on $H^d(\tilde{\mathbf{P}})$ on any $m \in M$:

$$\nu_c(m) = \left[\Phi^*(c(\tilde{\mathbf{P}})) \right]_{(d, 0)}(m)$$

All of the above classes are defined on $\tilde{\mathcal{B}}^*$. By pushing down via the forgetful map β , there is a natural way to obtain cohomology classes on \mathcal{B}^* .

Remarks:

1. If P is an $SU(2)$ bundle over a connected and simply-connected four manifold and $\Sigma_1, \dots, \Sigma_{h^2}$ are a basis for $H_2(X; \mathbf{Z})$, then the rational cohomology ring, $H^*(\mathcal{B}^*; \mathbf{Q})$, is a polynomial algebra on the generators: $\mu(\Sigma_1), \dots, \mu(\Sigma_{h^2})$, and ν , where ν is an extra generator in dimension four[67].
2. There is a construction of the cohomology classes, $\mu(\Sigma)$, as the first Chern classes of determinant line bundles of a family of Dirac operators on Σ [67].

15.8.2. Universal Connection

Finding an explicit representative of the characteristic classes on $\tilde{\mathcal{B}}^* \times M$ requires choosing an explicit connection. We follow the general construction used in chapter 14. We have $\mathcal{G} \times G$ invariant metrics on $\mathcal{A}^* \times P$. For $\tau_i \in T_A \tilde{\mathcal{A}}^*$ and $X_i \in T_p P$ we have

$$\begin{aligned} & \langle (X_1, \tau_1), (X_2, \tau_2) \rangle_{(p,A)} \\ &= g_{\mu\nu} X_1^\mu X_2^\nu(p) + \text{Tr} A(X_1)A(X_2) + \int_M \sqrt{g} d^4 x g^{\mu\nu} \text{Tr} \tau_{1\mu} \tau_{2\nu} \end{aligned} \quad (15.33)$$

The connection has a curvature $\mathcal{F} \in \Omega^2(\mathcal{A}^* \times P; \text{Lie } \mathcal{G} \oplus \underline{\mathfrak{g}})$ which is horizontal (but not invariant). Decomposing according to the natural bigrading we have

$$\begin{aligned} \mathcal{F}_{2,0}(\tau_1, \tau_2) &= -\frac{1}{D_A^\dagger D_A} [\tau_1, * \tau_2] \\ \mathcal{F}_{1,1}(X, \tau) &= \tau(X) \\ \mathcal{F}_{0,2}(X_1, X_2) &= F_A(X_1, X_2) \end{aligned} \quad (15.34)$$

where $\pi: P \rightarrow M$ is the projection.

This connection descends to a G -connection on $\tilde{\mathbf{P}}$ called the universal connection. Using (15.34) we can then find explicit representatives for $c_r \in H^{2r}(\tilde{\mathcal{B}}^* \times M)$ from

$$c_r \equiv \frac{1}{r!(2\pi i)^r} \text{Tr} \mathcal{F}^r \quad (15.35)$$

Remarks:

1. The universal connection may be described in a way very similar to (13.17). Recall that $\tilde{\mathcal{B}}^*$ parametrizes classes of G -connections. Denote by $[A(p, y)]$ the class parametrized by a coordinate $y \in \tilde{\mathcal{B}}^*$. A G -connection on $\tilde{\mathcal{B}}^* \times P$ is a $\underline{\mathfrak{g}}$ -valued one-form. The components of this one-form along P form a G -connection on P , hence define a point in $\tilde{\mathcal{B}}^*$. The universal connection has the property that the components along P at (p, y) define the class $[A(p, y)]$.
2. The universal connection descends to a connection on moduli space which can be described in more down-to-earth terms as follows. Suppose $A_\mu(x, Z)$ is a family of ASD instantons parametrized by some coordinates Z^i . Tangent vectors, $\frac{\partial}{\partial Z^i}$, to a horizontal slice for \mathcal{M}_+ correspond to elements of $\Omega^1(M; \underline{\mathfrak{g}})$ given by

$$\delta_i A_\mu = \frac{\partial}{\partial Z^i} A_\mu - D_\mu \epsilon_i$$

The $D_\mu \epsilon_i$ corresponds to a gauge transformation which we perform in order to keep the vector tangent to the moduli space (i.e. we require $D_A^\mu (\delta_i A_\mu) = 0$). Now we introduce $s_i = \partial_i + [\epsilon_i, \cdot]$ which defines a G -connection on $\mathcal{M}^+ \times M$ through the covariant derivative $\mathcal{D} = dZ^i s_i + dx^\mu D_\mu$. One checks that \mathcal{D}^2 has the components given in (15.34). This description appears in an intriguing interpretation of the Donaldson map and polynomial in the context of the theory of heterotic string fivebranes, discussed by J. Harvey and A. Strominger in [102].

15.8.3. QFT Representative

Let us return to the BRST complex of section 15.5. The relations (15.10) and (15.11) are the standard Weil algebra relations, so if we consider

$$\widehat{\mathcal{O}}_r \equiv \frac{1}{r!(2\pi i)^r} \text{Tr } \mathbb{F}^r \quad (15.36)$$

This will be $d + d_B$ -closed by standard arguments. Given the bigrading into ghost number and form degree, we may decompose this according to its spacetime form degree as in equation (13.22) for the topological sigma model

$$\widehat{\mathcal{O}}_r \equiv \widehat{\mathcal{O}}_r^{(0)} + \dots + \widehat{\mathcal{O}}_r^{(4)} \quad (15.37)$$

where $\mathcal{O}_r^{(i)}$ is a spacetime i -form. Now

$$(d + d_B)\widehat{\mathcal{O}}_r = 0 \quad (15.38)$$

leads to the descent equations

$$\begin{aligned} d\widehat{\mathcal{O}}_r^{(4)} &= 0 \\ d\widehat{\mathcal{O}}_r^{(3)} &= -\{Q, \widehat{\mathcal{O}}_r^{(4)}\} \\ d\widehat{\mathcal{O}}_r^{(2)} &= -\{Q, \widehat{\mathcal{O}}_r^{(3)}\} \\ d\widehat{\mathcal{O}}_r^{(1)} &= -\{Q, \widehat{\mathcal{O}}_r^{(2)}\} \\ d\widehat{\mathcal{O}}_r^{(0)} &= -\{Q, \widehat{\mathcal{O}}_r^{(1)}\} \\ 0 &= \{Q, \widehat{\mathcal{O}}_r^{(0)}\} \end{aligned} \quad (15.39)$$

We can therefore form the BRST invariant observables

$$\widehat{W}_r(\gamma) \equiv \int_\gamma \widehat{\mathcal{O}}_r^{(k)} \quad (15.40)$$

by integration over a cycle $\gamma \in H_k(M)$, thus providing a map

$$H_k(M) \rightarrow H_Q^{2r-k}(\hat{\mathcal{F}}(\mathcal{A})) \quad (15.41)$$

Clearly the parallels between the mathematical and QFT construction are very close. The precise relation is provided by the natural connection on \mathcal{A} , induced by \mathcal{G} -invariant metric, (15.33). We may think of this connection as a Chern-Weil homomorphism, $w_{\mathfrak{g}}$. Then given $A \in \mathcal{A}$ we may regard:

$$A + w_{\mathfrak{g}}(c) \in \Omega^1(\mathcal{A} \times P; \text{Lie } \mathcal{G} \oplus \underline{\mathfrak{g}}) \quad (15.42)$$

as a “universal connection” on $\mathcal{A} \times P$. The curvature of this connection is

$$\mathcal{F} = F + \psi + w_{\mathfrak{g}}(\phi) \in \Omega^2(\mathcal{A} \times P; \text{Lie } \mathcal{G} \oplus \underline{\mathfrak{g}}) \quad (15.43)$$

The expression $\psi = \tilde{d}A_\mu \otimes dx^\mu$ may be regarded as an element of $\Omega^{1,1}(\mathcal{A} \times P; \underline{\mathfrak{g}})$. Its value on a tangent vector is given by:

$$\psi_{A,p}(\tau, X_p) = \tau_p(\pi_* X_p) \in \underline{\mathfrak{g}}$$

where $(\tau, X_p) \in T_{(A,p)}(\mathcal{A} \times P) = \Omega^1(M; \underline{\mathfrak{g}}) \oplus T_p P$. Thus, \mathbb{F} in (15.10) becomes the curvature of the universal connection and $\hat{\mathcal{O}}_r$ is a basic form which descends to a characteristic class of \mathcal{Q} in $H^{2r}(\mathcal{A}/\mathcal{G} \times M)$. We thus recognize the observables $\widehat{W}_r(\gamma)$ as those given by the Donaldson map, $\mu(\gamma)$.⁴⁵

Remark: It is interesting to compare classes in $H^\bullet(BG)$ for G compact with the above classes. Let us take, for example, $G = SU(N)$. In this case $\text{Tr } \phi^{j+1}$ generate the cohomology ring for $j = 1, \dots, N-1$. The analog of ϕ for $\text{Lie } \mathcal{G}$ is $\phi(x)$, but the analog of $\text{Tr } \phi^{j+1}$ is not just $\text{Tr } \phi^{j+1}(x)$. While these do generate BRST classes, by the descent equations, the x -dependence does *not* lead to independent cohomology classes. Moreover, forming invariant polynomials on the Lie algebra, we miss the cohomology classes associated to other elements of $H_\bullet(M)$.

⁴⁵ Related discussions appear in [34,201].

15.9. Correlation Functions

We are now set up to present Witten's path-integral formulation of the Donaldson invariants. Using the basic result (14.65) we have

$$\frac{1}{\text{vol } \mathcal{G}} \int d\phi \hat{\mu} e^{-I_{\text{Donaldson}}} \prod \widehat{W}^{r_i}(\gamma_i) = \int_{\mathcal{M}_+} \prod \omega_{r_i}(\gamma_i) \chi(\text{cok}(\mathbb{O})/\mathcal{G}) \quad (15.44)$$

where $\omega_{r_i}(\gamma_i) = w_{\natural}(\widehat{W}^{r_i}(\gamma_i))$. ∇s may be identified with the operator:

$$p_+ D_A : \Omega^1(M; \underline{\mathfrak{g}}) \rightarrow \Omega^{2,+}(M; \underline{\mathfrak{g}}) \quad (15.45)$$

and the operator \mathbb{O} of sec. 14.4.2 is

$$\mathbb{O} = \begin{pmatrix} p_+ D_A^{(1)} \\ (D_A^{(0)})^\dagger \end{pmatrix} \quad (15.46)$$

These operators fit into the well-known Atiyah-Hitchin-Singer instanton deformation complex [10]:

$$0 \longrightarrow \Omega^0(M; \underline{\mathfrak{g}}) \xrightarrow{D_A^{(0)}} \Omega^1(M; \underline{\mathfrak{g}}) \xrightarrow{p_+ D_A^{(1)}} \Omega^{2,+}(M; \underline{\mathfrak{g}}) \longrightarrow 0 \quad (15.47)$$

The complex (15.47) is used to study the tangent space to the moduli space \mathcal{M}_+ . The index of the complex (15.47) was computed to be⁴⁶

$$\begin{aligned} \text{ind}(\mathcal{C}, D_A^*) &= p_1(\underline{\mathfrak{g}}) - \frac{1}{2} \dim G (\chi(M) + \tau(M)) \\ &= 4h_G k - \frac{1}{2} \dim G (\chi(M) + \tau(M)) \end{aligned}$$

where h_G is the dual Coxeter number of G and k is the instanton number of the connection.

For generic situations⁴⁷ the connection is irreducible ($h^0 = 0$) and there are no further obstructions ($h^2 = 0$). In this case

$$\dim \mathcal{M}_+(M, G; k) = 4h_G k - \frac{1}{2} \dim G (\chi(M) + \tau(M)) \quad (15.49)$$

⁴⁶ Note that we have adopted the following convention for the sign of $\tau(M)$: If $\dim M = 4n$, then

$$\tau(M) = b_{2n}^+ - b_{2n}^- \quad (15.48)$$

⁴⁷ See [85,67,106] for a detailed discussion of these points.

and at the smooth points of \mathcal{M}^+ , we have $T\mathcal{M}^+ \cong \ker(p_+D_A)/\text{Im}D_A$. Moreover

$$\ker\mathbb{O} \cong \ker\nabla\bar{s} \cong \ker(p_+D_A^1 \oplus (D_A^{(0)})^\dagger) \cong \ker(p_+D_A^1)/\text{Im}D_A$$

so we recover (11.47). Moreover, generically $\text{cok } p_+D_A = 0$, so $\chi(\text{cok}\nabla s)$ is a constant ($= \pm 1$) on each component of the moduli space. Therefore, on the instanton number k component of \mathcal{M}_+ the correlator (15.44) must satisfy the ghost number selection rule

$$\sum_i \text{ghost}\#(\widehat{W}^{r_i}(\gamma_i)) = \sum_i (2r_i - k_i) = 4h_G k - \frac{1}{2} \dim G (\chi(M) + \tau(M)) \quad (15.50)$$

where $\gamma_i \in H_{k_i}(M)$ in order to obtain a nonzero answer.

15.9.1. Reducible connections

The above discussion has ignored an important subtlety: the moduli space \mathcal{M}_+ has singularities. One source of these singularities are reducible connections. These correspond to connections $A \in \mathcal{A}$, where the isotropy group, $\Gamma_A \subset \mathcal{G}$, is non-minimal⁴⁸, i.e. there exist non-trivial $\phi \in \mathcal{G}$, such that $D_A\phi = 0$. Correspondingly there exist nontrivial zero modes of $C^\dagger C$, so that this operator is not invertible. A glance at (14.26) and (15.26) shows that such connections lead to singularities in the path integral measure. One cannot neglect these singularities in calculations of topological invariants.

One, more physical, way to express the problem of reducible connections is the following [229]. The path integral should localize to the Q -fixed points; these follow from the RHS of (15.16) and (15.9), and are given by

$$\begin{aligned} H &= \frac{i}{2t} F^+ = 0 \\ D_A\phi &= 0 \\ [\phi, \lambda] &= 0 \end{aligned} \quad (15.51)$$

The branch of solutions to these equations containing irreducible connections has $\phi = 0$. λ is unconstrained, but its integral leads to a delta function as we have seen. However, at the reducible connections there are nonzero solutions for ϕ . Thus, the space of Q -fixed points is larger than the space we wish to localize to. Worse, this space is noncompact and the definition of the integration over this noncompact region has been problematic.

⁴⁸ Equivalently, for these connections the holonomy group is smaller than G .

15.10. The canonical formulation: Floer Homology

The canonical formulation of Donaldson theory involves Floer homology for 3-folds. Indeed Floer theory played a crucial role in the origin of cohomological field theory. For further information see [83,14,44,218].

15.11. Relation to “physical” Yang-Mills: $D = 4$

15.11.1. The $N = 2$ Lagrangian

This is discussed in [47,213,197,233], as well as in many other references. We shall obtain $N = 2$ super Yang-Mills theory in $d = 4$ from the dimensional reduction of $N = 1$ SYM in $d = 6$. The field content of the six dimensional theory is simply a vector field, \mathbf{A}_μ , and a fermion, Λ . The theory has a simple action:

$$I_{d=6, N=1} = \int d^6x \sqrt{g} \left\{ -\frac{1}{4} \text{Tr} F_{\mu\nu} F^{\mu\nu} + i \text{Tr} \bar{\Lambda} \Gamma^\mu (D_{\mathbf{A}})_\mu \Lambda \right\} \quad (15.52)$$

where $D_{\mathbf{A}}$ is the gauge covariant derivative. The action is invariant under the supersymmetry transformations:

$$\begin{aligned} \delta \mathbf{A}_\mu &= i \bar{E} \Gamma_\mu \Lambda - i \bar{\Lambda} \Gamma_\mu E \\ \delta \Lambda &= \Sigma^{\mu\nu} F_{\mu\nu} E \\ \delta \bar{\Lambda} &= -\bar{E} \Sigma^{\mu\nu} F_{\mu\nu} \end{aligned} \quad (15.53)$$

where $\Sigma^{\mu\nu} = \frac{1}{4} (\Gamma^\mu \Gamma^\nu - \Gamma^\nu \Gamma^\mu)$ and E is a Grassmann supersymmetry transformation parameter.

We make the following choice for the representation of the Γ matrices in six dimensional Euclidean space, which is convenient in what follows

$$\Gamma^m = \begin{pmatrix} \gamma^m & 0 \\ 0 & \gamma^m \end{pmatrix} \quad m = 0, \dots, 3 \quad (15.54)$$

$$\Gamma^4 = \begin{pmatrix} 0 & i\gamma_5 \\ i\gamma_5 & 0 \end{pmatrix} \quad \Gamma^5 = \begin{pmatrix} 0 & \gamma_5 \\ -\gamma_5 & 0 \end{pmatrix} \quad \Gamma^7 = \begin{pmatrix} \gamma_5 & 0 \\ 0 & -\gamma_5 \end{pmatrix}$$

where $\Lambda = \begin{pmatrix} \Lambda_L \\ \bar{\Lambda}_R \end{pmatrix}$ is a left-handed six dimensional Weyl spinor. Separately Λ_L and Λ_R are (in our choice of representations of the Dirac matrices) left-handed and right-handed four dimensional Dirac matrices. We may write

$$\Lambda_L = \begin{pmatrix} \lambda_L \\ 0 \end{pmatrix} \quad \Lambda_R = \begin{pmatrix} 0 \\ \bar{\lambda}_R \end{pmatrix}$$

These may be combined into a single four-dimensional Dirac spinor

$$\lambda = \begin{pmatrix} \lambda_L \\ \bar{\lambda}_R \end{pmatrix}$$

Now introduce

$$\begin{aligned} A_m &= \mathbf{A}_m \quad m = 0, \dots, 3 \\ B &= \frac{1}{\sqrt{2}}(\mathbf{A}_4 - i\mathbf{A}_5) \quad \bar{B} = \frac{1}{\sqrt{2}}(\mathbf{A}_4 + i\mathbf{A}_5) \end{aligned} \quad (15.55)$$

We dimensionally reduce by eliminating x^4, x^5 dependence of the fields. It is a simple matter to obtain the dimensionally reduced action expressed in terms of the fields above [47,213,197,233]:

$$\begin{aligned} I_{N=2 \text{ SYM}} &= \int \sqrt{g} d^4x \text{ Tr} \left\{ -\frac{1}{4} F_{mn} F^{mn} - (D_A \bar{B})_m (D_A B)^m - \frac{1}{2} [B, \bar{B}]^2 \right. \\ &\quad \left. - i \bar{\lambda}_{\dot{\alpha}i} (\bar{\sigma} \cdot D_A)^{\dot{\alpha}\alpha} \lambda_{\alpha}^i + \frac{i}{\sqrt{2}} B \epsilon^{ij} [\bar{\lambda}_{\dot{\alpha}i}, \bar{\lambda}_{\dot{\alpha}j}] - \frac{i}{\sqrt{2}} \bar{B} \epsilon_{ij} [\lambda^{\alpha i}, \lambda_{\alpha}^j] \right\} \end{aligned} \quad (15.56)$$

From (15.53) we find that the supersymmetry transformations in $d = 4$ are given by

$$\begin{aligned} \delta A_m &= -i \bar{\lambda}_{\dot{\alpha}i} \bar{\sigma}_m^{\dot{\alpha}\alpha} \epsilon_{\alpha}^i + i \bar{\epsilon}_{\dot{\alpha}i} \bar{\sigma}_m^{\dot{\alpha}\alpha} \lambda_{\alpha}^i \\ \delta \lambda_{\alpha}^i &= \sigma^{mn}{}_{\alpha\beta} \epsilon^{\beta i} F_{mn} + i \epsilon_{\alpha}^i [B, \bar{B}] + i \sqrt{2} \sigma^m{}_{\alpha\dot{\alpha}} D_m B \epsilon^{ij} \bar{\epsilon}^{\dot{\alpha}j} \\ \delta \bar{\lambda}_{\dot{\alpha}i} &= \bar{\sigma}^{mn}{}_{\dot{\alpha}\dot{\beta}} \bar{\epsilon}^{\dot{\beta}i} F_{mn} - i \bar{\epsilon}_{\dot{\alpha}i} [B, \bar{B}] + i \sqrt{2} \sigma^m{}_{\alpha\dot{\alpha}} D_m \bar{B} \epsilon_{ij} \epsilon^{\alpha j} \\ \delta B &= \sqrt{2} \epsilon^{\alpha i} \lambda_{\alpha i} \\ \delta \bar{B} &= \sqrt{2} \bar{\epsilon}^{\dot{\alpha}i} \bar{\lambda}_{\dot{\alpha}i}, \end{aligned} \quad (15.57)$$

The classical theory possesses a global $SU(2)_L \times SU(2)_R \times U(2)_I$ symmetry group. $SU(2)_L \times SU(2)_R$ is the local Lorentz group and the $U(2)_I$ is the “ R -symmetry” of $N = 2$ supersymmetry. The various fields of the action transform as follows under this symmetry:

$$\begin{aligned} \lambda_{\alpha}^i & \quad (2, 1, 2^{+1}) \\ \bar{\lambda}_{\dot{\alpha}i} & \quad (1, 2, 2^{-1}) \\ B & \quad (1, 1, 1^2) \\ \bar{B} & \quad (1, 1, 1^{-2}), \end{aligned}$$

and the supercharges transform as $(2, 1, 2^{-1}) \oplus (1, 2, 2^{+1})$ (the superscript in the third entry denoting the $U(1)$ charge in $U(2)_I$). These symmetries will play a role in making a topological theory from the physical $N = 2$ theory.

15.11.2. Topological Twisting

Historically, Donaldson theory provided the first example of a topological twisting of an $N = 2$ theory[218]. The procedure is analogous to that of sec. 13.10.4.

Since the local Lorentz group is $SO(4) \cong SU(2)_L \times SU(2)_R$, we may decompose the spin connection: $\omega_m = ((\omega_L)_m, (\omega_R)_m)$. To twist the physical theory, we now gauge the $SU(2)_I$ with external gauge fields, B_m . As in the topological sigma model, we next consider “diagonal” correlators with B_m related to $(\omega_R)_m$. The remaining symmetry group is $SU(2)_L \times SU(2)'_R \times U(1)_G$ (the $U(1)_G$ now being interpreted as “ghost number”) where $SU(2)'_R$ is diagonally embedded in $SU(2)_R \times SU(2)_I$. In particular, the supercharges now transform as:

$$(2, 2, -1) \oplus (1, 3, 1) \oplus (1, 1, 1) \quad (15.58)$$

under $SU(2)_L \times SU(2)'_R \times U(1)_G$. The first two are vectors and self-dual tensors, respectively. Since a general 4-manifold does not admit nonvanishing vectors or self-dual forms these charges will not, in general, exist on arbitrary 4-manifolds. The last is identified with the BRST operator. Being a scalar it can be defined on a general 4-manifold. If M is a Kähler manifold there is a second globally defined BRST operator. This has recently been exploited in [233] to derive some explicit formulae for the Donaldson invariants.

It is convenient to relabel the fields of the twisted theory in a way that reflects their transformation behaviour under the new embedding of the local Lorentz group[233]. For the supersymmetry generators:

$$\begin{aligned} \epsilon^{\alpha i} &\longrightarrow 0 \\ \bar{\epsilon}^{\dot{\alpha} i} &\longrightarrow -\epsilon^{\dot{\alpha} \beta} \rho \end{aligned}$$

while for the fields

$$\begin{aligned} \psi_m &= \frac{1}{2} \bar{\sigma}_m^{i\alpha} \lambda_{\alpha i} \\ \chi_{mn} &= \frac{1}{2} \bar{\lambda}^{\dot{\alpha} i} \bar{\sigma}_{mn}^i{}_{\dot{\alpha}} \\ \eta &= \bar{\lambda}^{\dot{\alpha} \dot{\alpha}} \\ \phi &= \frac{i}{\sqrt{2}} B \\ \lambda &= \bar{B} \end{aligned}$$

In terms of these fields and supersymmetry generators, the topological supersymmetry transformations are quite familiar

$$\begin{aligned}
\delta A_m &= i\rho\psi_m \\
\delta\psi_m &= -\rho D_m\phi \\
\delta\phi &= 0
\end{aligned}
\tag{15.59}$$

15.11.3. Comparison to the MQ form

As with the sigma model, when comparing the MQ form to the twisted $N = 2$ theory there is a difference. In this case the difference consists of a topological term for the gauge fields and a term involving the potential energy for the scalar fields. The topological term is simply the Pontryagin index. The other term is Q -exact and is given by:

$$\begin{aligned}
\Delta I = Q\Delta\Psi &= \int d^4x\sqrt{g} \operatorname{Tr} (-\eta[\phi, \eta] + [\phi, \lambda]^2) \\
\Delta\Psi &= \int d^4x\sqrt{g} \operatorname{Tr} (\eta[\phi, \lambda])
\end{aligned}
\tag{15.60}$$

We must also rotate $\phi \rightarrow i\phi$ to compare to the physical theory. Note from (15.55) that in the physical theory $i\phi$ and λ^* are proportional complex fields, while in the topological theory it is more natural to take ϕ and λ to be real.

15.11.4. The Energy-Momentum Tensor

As we mentioned in chapter 11 in our general discussion of topological actions, the cohomology class defined by the path integral is independent of metric on the bundle $E_{\text{localization}}$. Thus, even though a metric is used to construct the Donaldson Lagrangian, the correlation functions, being topological intersection numbers, cannot depend on the choice of metric on spacetime. Physically this arises from the key fact that the energy-momentum tensor is a BRST commutator. That in turn follows immediately from the BRST exactness of the action

$$\begin{aligned}
T_{\mu\nu} &= \{Q, \lambda_{\mu\nu}\} \\
\lambda_{\mu\nu} &= \frac{1}{\sqrt{g}} \frac{\delta}{\delta g^{\mu\nu}} \Psi
\end{aligned}
\tag{15.61}$$

15.12. Relation to “physical” Yang-Mills: $D = 2$

The relation of the physical and cohomological Yang-Mills theories in two dimensions is very intriguing and was described in [227]. As we have seen, the cohomological theory localizes to the space of *flat connections*. Let us re-examine the physical theory.

As discussed in section 11.12.3, the path integral of the physical theory can be written as in (11.66). From this equation we see that the action is a sum of two BRST invariant operators in a cohomological gauge theory on Σ with basic multiplet A , ψ and ϕ . Indeed, in a cohomological gauge theory the BRST class of $\text{Tr } \phi^2$ is independent of P , hence the action (11.66) is just

$$I = i\mathcal{O}_2^{(2)}(\Sigma) + \epsilon a \mathcal{O}_2^{(0)}(P) \quad (15.62)$$

up to a BRST commutator. Moreover, as discussed in section 11.12.3, $\mathcal{O}_2^{(2)}(\Sigma)$ is just the equivariantly closed symplectic form of section 10.10, and (11.66) is the equivariant integration of the exponential of the equivariant symplectic form.

These two observations lead to a relation between the physical and cohomological gauge theories. Recall that to discuss localization of integrals of equivariant differential forms we must add a G -invariant one-form λ , and perturb by $tD\lambda$. This perturbation can then be interpreted as a Q -exact action in a cohomological gauge theory. In this case we take (11.69) from section 11.12.3.

In [227] Witten shows that the cohomological theory with gauge fermion (11.69) is equivalent to a theory with gauge fermion:

$$\Psi = \Psi_{\text{Donaldson}} + \frac{1}{te^2} \int_{\Sigma} \text{Tr } \chi \lambda \quad (15.63)$$

He then shows that the theory with gauge fermion (15.63) is equivalent to $D = 2$ Donaldson theory with the standard gauge fermion (15.22) + (15.17), up to terms of order $\sim \mathcal{O}(e^{-c/te^2})$ for $t \rightarrow 0^+$. The difference comes about because the second term in (15.63) introduces new Q -fixed points.

The result is that the generator of intersection numbers on the moduli space of flat connections is related to the physical partition function by

$$\begin{aligned} \frac{1}{\text{vol}(\mathcal{G})} \int DA \exp \left[\frac{2\pi^2}{\epsilon} \int_{\Sigma} d\mu \text{Tr } f^2 \right] \\ = e^{\alpha_1(2-2p)} \sum_R (\dim R)^{2-2p} e^{-e^2 a(C_2(R) + \alpha_2)} \\ = \langle e^{\omega + \epsilon a \mathcal{O}^{(0)}} \rangle_{\mathcal{M}_N} + \mathcal{O}(e^{-c/(\epsilon a)}) \end{aligned} \quad (15.64)$$

where \mathcal{M}_N is the moduli space of flat connections on Σ for $G = SU(N)$. Formulae for the renormalization constants α_1, α_2 are given in [152].

Remarks:

1. As emphasized in [227], (15.64) shows that the leading term for $e^2 \rightarrow 0$ only has polynomial dependence, of order $\frac{1}{4} \dim \mathcal{M}_N = \frac{1}{2}(G-1)(N^2-1)$.
2. Reference [169] makes the interesting suggestion that one can apply the ideas of non-abelian localization to $D = 4$ topological Yang-Mills theory.

15.12.1. Holomorphic maps and flat connections

We can combine the results of the present section with those from chapter 7 to discover a relation between the moduli spaces of holomorphic maps of Riemann surfaces $\Sigma_W \rightarrow \Sigma_T$ (Hurwitz space) and those of the moduli of flat $SU(N)$ bundles over Σ_T .

Consider (15.64) for $N \rightarrow \infty$. In order to define the large N limit we must hold $N\epsilon = \lambda$ fixed. Thus, the contributions of the unstable solutions are exponentially small for $N \rightarrow \infty$, that is, *physical YM₂ and D = 2 Donaldson theory are identical at large N*. Combining this with the results of part I, we obtain a relation between intersection theory of the moduli space of flat connections on Σ_T and intersection theory for the moduli space of holomorphic maps into Σ_T ⁴⁹:

$$\left\langle \exp \left[\omega + \frac{8\pi^2 a}{N} \mathcal{O}^{(0)} \right] \right\rangle_{\mathcal{M}(F=0, \Sigma_T, SU(N))} \stackrel{N \rightarrow \infty}{\sim} \sum_{\chi} N^{\chi} \sum_{d \geq 0} e^{-\frac{1}{2} da} P_d(a) \chi_{\text{orb}}(\mathcal{CH}(\Sigma_W, \Sigma_T, d)) \tag{15.65}$$

where $\mathcal{CH}(\Sigma_W, \Sigma_T, d)$ is the coupled Hurwitz moduli space for maps of degree d , which discussed in chapter 7. $P_d(a)$ is a polynomial with $P_d(0) = 1$. We will return to this formula in the concluding chapter.

⁴⁹ To make this statement rigorous one must (a.) take care of the singularities in \mathcal{M} and (b.) ensure that the corrections $\sim \mathcal{O}(e^{-2Nc/\lambda})$ from (11.70) are not overwhelmed by the “entropy of unstable solutions” [95]. The absence of phase transitions as a function of λ for $G > 1$ suggests that, for $G > 1$, these terms are indeed $\sim \mathcal{O}(e^{-Nc'})$ for some constant c' .

16. 2D Topological Gravity

At the fundamental level, 2D topological gravity is the study of intersection theory on the moduli space $\mathcal{M}_{h,n}$ of Riemann surfaces of genus h with n punctures through field-theoretic methods. There are many ways of describing the moduli $\mathcal{M}_{h,n}$ and correspondingly many different field theoretic formulations. How one describes the theory by equations, fields, and symmetries depends on which formulation of moduli space one uses. This has led to a bewildering jungle of formulations in the literature. In our opinion a satisfactory field theoretic formulation of topological gravity remains to be completed.

16.1. Formulation 1: $\mathcal{G} = \text{Diff}(\Sigma) \ltimes \text{Weyl}(\Sigma)$

Ideally we would like to have no equations at all. For the above group we can take universal bundle and classifying space to be

$$\begin{aligned} E\mathcal{G} &= \text{MET}(\Sigma) \\ B\mathcal{G} &= \mathcal{M}_{h,0}. \end{aligned} \tag{16.1}$$

16.1.1. BRST Complex

Algebraically we can formulate the complexes for equivariant cohomology as:

A. BRST Model

The generators of the complex are:

$$\begin{aligned} h_{\alpha\beta} &\in \Omega^0(\text{MET}) & \psi_{\alpha\beta} &= \tilde{d}h_{\alpha\beta} \in \Omega^1(\text{MET}) \\ c^\alpha &\in \mathcal{W}^1(\text{diff}) & \gamma^\alpha &\in \mathcal{W}^2(\text{diff}) \\ \rho &\in \mathcal{W}^1(\text{weyl}) & \tau &\in \mathcal{W}^2(\text{weyl}) \end{aligned} \tag{16.2}$$

Translating (10.19) into the present example we find:

$$\begin{aligned} d_B h_{\alpha\beta} &= \psi_{\alpha\beta} + \mathcal{L}_c h_{\alpha\beta} - \rho h_{\alpha\beta} \\ d_B \psi_{\alpha\beta} &= \mathcal{L}_c \psi_{\alpha\beta} - \rho \psi_{\alpha\beta} - \mathcal{L}_\gamma h_{\alpha\beta} + \tau h_{\alpha\beta} \\ d_B c^\alpha &= \gamma^\alpha - \frac{1}{2}[c, c]^\alpha \\ d_B \gamma^\alpha &= \mathcal{L}_c \gamma^\alpha \\ d_B \rho &= \tau + \mathcal{L}_c \rho \\ d_B \tau &= \mathcal{L}_c \tau - \mathcal{L}_\gamma \rho. \end{aligned} \tag{16.3}$$

The occurrence of Lie derivatives with respect to c^α in the last two formulae arises because we actually have a *semi-direct* product of Diff and Weyl. Exactly this multiplet of fields was used in the formulation of 2D topological gravity in [132].

B. Cartan Model

This is easily obtained from the BRST model by setting the odd (degree one) generators to zero. In this case the generators of the complex are:

$$\begin{aligned} h_{\alpha\beta} &\in \Omega^0(\text{MET}) & \psi_{\alpha\beta} &= \tilde{d}h_{\alpha\beta} \in \Omega^1(\text{MET}) \\ \gamma^\alpha &\in \mathcal{W}^2(\text{diff}) & \tau &\in \mathcal{W}^2(\text{weyl}) \end{aligned} \tag{16.4}$$

Translating (10.16) into the present example we find:

$$\begin{aligned} d_{\mathcal{C}}h_{\alpha\beta} &= \psi_{\alpha\beta} \\ d_{\mathcal{C}}\psi_{\alpha\beta} &= -\mathcal{L}_\gamma h_{\alpha\beta} + \tau h_{\alpha\beta} \\ d_{\mathcal{C}}\gamma^\alpha &= 0 \\ d_{\mathcal{C}}\tau &= 0 \end{aligned} \tag{16.5}$$

16.1.2. Lagrangian

There is no localization Lagrangian so we must only construct projection and gauge-fixing Lagrangians. Here we meet a new element. The construction of the projection Lagrangian in Chapter 14 requires a \mathcal{G} -connection on the principal $E\mathcal{G}$ bundle MET. In Chapter 14 this was constructed using a \mathcal{G} -invariant metric. The natural metric on MET is

$$(\delta h^{(1)}, \delta h^{(2)}) = \int_{\Sigma} d^2z \sqrt{h} (h^{\alpha\gamma} h^{\beta\delta} + t h^{\alpha\beta} h^{\gamma\delta}) \delta h_{\alpha\beta}^{(1)} \delta h_{\gamma\delta}^{(2)} \tag{16.6}$$

where t is an arbitrary positive real number⁵⁰. Unfortunately, the general construction of section 14.3 cannot be applied because the metric (16.6) is *not* Weyl invariant, nor is the corresponding metric on Diff(Σ).

Nevertheless, the general reasoning of section 14.3 can be applied. All we really need to construct $\Phi(P \rightarrow M)$ is a vertical 1-form, valued in a vector bundle, that is, an analogue of C^\dagger . In the present case we can construct a one-form whose kernel is the space of solutions to

$$P^\dagger \delta h_{\alpha\beta} = D^\alpha \delta h_{\alpha\beta} = 0. \tag{16.7}$$

⁵⁰ The restriction of t to positive real numbers ensures that the metric is positive definite.

where

$$(P\xi)_{\alpha\beta} = D_{(\alpha}\xi_{\beta)} - h_{\alpha\beta}D \cdot \xi, \quad (16.8)$$

(The notation P and P^\dagger is standard in string theory.) In conformal coordinates such zero modes are given by $\delta h_{zz}(dz)^2$ which are holomorphic quadratic differentials $\in H^0(\Sigma; K^2)$. Let $\Pi_{\alpha\beta}^{\gamma\delta}$ be the projection onto $H^0(\Sigma; K^2)$ ⁵¹. Then $C^\dagger = \Pi_{\alpha\beta}^{\gamma\delta} \psi_{\gamma\delta}$

For antighosts we introduce $\lambda^{\alpha\beta}$ and $\eta^{\alpha\beta}$; we form⁵²

$$\Psi_{\text{projection}} = i(\lambda, C^\dagger) = \int_{\Sigma} d^2z \sqrt{h} \lambda^{\alpha\beta} \Pi_{\alpha\beta}^{\gamma\delta} \psi_{\gamma\delta} \quad (16.9)$$

We must also introduce a gauge-fixing term in the standard way by using the BRST model, choosing a slice $h_{\alpha\beta}^{(0)}$ for \mathcal{G} and introducing:

$$\Psi_{\text{gauge-fixing}} = \int d^2z \sqrt{h} b^{\alpha\beta} (h_{\alpha\beta} - h_{\alpha\beta}^{(0)}) \quad (16.10)$$

where $Qb^{\alpha\beta} = d^{\alpha\beta}$ and $b^{\alpha\beta}, d^{\alpha\beta}$ are symmetric tensors of ghost number -1 and 0 , respectively.

The Lagrangian can now be easily worked out. The slice is $6h - 6$ dimensional. That is, in MET almost all ($\infty - (6h - 6)$) directions are vertical. For the moment let us assume that, in fact, *all* directions are vertical. Then we could simply take $C^\dagger = \psi$ and drop the $\Pi_{\alpha\beta}^{\gamma\delta}$ in (16.9). Applying the BRST model differential we arrive at the Lagrangian:

$$\begin{aligned} & d_B(\Psi_{\text{projection}} + \Psi_{\text{gauge fixing}}) \\ &= \int d^2z \sqrt{h} \left\{ \eta^{\alpha\beta} \psi_{\alpha\beta} + \lambda^{\alpha\beta} (\tau h_{\alpha\beta} - D_{(\alpha} \gamma_{\beta)}) \right\} \\ &+ \int \sqrt{h} d^2z \left\{ d^{\alpha\beta} (h_{\alpha\beta} - h_{\alpha\beta}^{(0)}) - b^{\alpha\beta} \psi_{\alpha\beta} - b^{\alpha\beta} (D_{(\alpha} c_{\beta)} - \rho h_{\alpha\beta}) \right\} \\ &+ \int \sqrt{h} d^2z \frac{1}{2} h^{\alpha\beta} (\mathcal{L}_c h_{\alpha\beta} - h_{\alpha\beta} \rho) \left\{ \lambda^{\gamma\delta} \psi_{\gamma\delta} + b^{\gamma\delta} (h_{\gamma\delta} - h_{\gamma\delta}^{(0)}) \right\} \end{aligned} \quad (16.11)$$

⁵¹ In terms of the P , this is

$$\Pi_{\alpha\beta}^{\gamma\delta} = (\mathbf{1} - P \frac{1}{P^\dagger P} P^\dagger)_{\alpha\beta}^{\gamma\delta}$$

modulo some complications which occur in low genus due to the nontriviality of the kernel of $P^\dagger P$.

⁵² The antighosts do not live in the Lie algebra because we are not using the canonical connection employed in chapter 14.

Physically, we may integrate out fields to simplify the Lagrangian: Integrating out $\eta^{\alpha\beta}$ sets $\psi_{\alpha\beta} = 0$. Integrating out $d^{\alpha\beta}$ sets $h_{\alpha\beta} = h_{\alpha\beta}^{(0)}$. Integrating out τ and ρ , makes λ and b traceless. We are then left with:

$$\int d^2z \sqrt{h} \left[b^{\alpha\beta} D_{(\alpha} c_{\beta)} - \lambda^{\alpha\beta} D_{(\alpha} \gamma_{\beta)} \right] \quad (16.12)$$

Geometrically the integral on η produces a totally vertical form, so we may drop ψ in the remainder of the Lagrangian while the integral over $d^{\alpha\beta}$ produces a Poincaré dual in the space of metrics to the slice $h_{\alpha\beta}^{(0)}$.

The field $\lambda^{\alpha\beta}$ is usually denoted β and equation (16.12) is the “ $bc\beta\gamma$ ” formulation of 2D gravity obtained in [132,63]. This field theory is an example of a conformal field theory with total conformal anomaly $c = -26 + 26 = 0$. As we saw in chapter 10, we expect such systems to arise in discussions of equivariant cohomology on very general grounds.

Finally, let us return to the complications of $\Pi_{\alpha\beta}^{\gamma\delta}$. There will be extra nonlocal terms from the variation of this projector. However, by introducing a finite set of quantum mechanical degrees of freedom (in correspondence with the superspace $\Pi T\mathcal{M}_{h,0}$) this nonlocality can be eliminated [132,27].

16.2. Formulation 2: $\mathcal{G} = \text{Diff}(\Sigma)$

We study $\text{Diff}(\Sigma)$ -equivariant cohomology of $\text{MET}(\Sigma)_k$, the space of metrics of constant scalar curvature $R = k$, where

$$k = \begin{cases} +1 & \text{if } g = 0 \\ 0 & \text{if } g = 1 \\ -1 & \text{if } g \geq 2 \end{cases}$$

16.2.1. Equations

The fundamental field variable will be $h_{\alpha\beta} \in \text{MET}(\Sigma)$. Therefore, we must localize to $\text{MET}(\Sigma)_k$. The equations will be

$$\mathcal{Z} = \{h \mid R(h) = k\} / \mathcal{G} \quad (16.13)$$

so $\mathcal{V} = \text{MET} \times \mathbb{R}$. The corresponding antighosts are $\rho, \pi \in \Omega^2(\Sigma)$. We take the trivial connection on $\mathcal{V} \rightarrow \text{MET}$.

16.2.2. BRST Complex

The BRST complex is easily obtained from the complex (16.4) and (16.3) by dropping Weyl degrees of freedom: $\rho, \tau \rightarrow 0$. As usual there are BRST and Cartan models. The Cartan model is especially simple, with generators:

$$h_{\alpha\beta} \in \Omega^0(\text{MET}) \quad \psi_{\alpha\beta} = \tilde{d}h_{\alpha\beta} \in \Omega^1(\text{MET}) \quad \gamma^\alpha \in \mathcal{W}^2(\text{diff}) \quad (16.14)$$

and Cartan differential, according to (10.16):

$$\begin{aligned} d_{\mathcal{C}}h_{\alpha\beta} &= \psi_{\alpha\beta} \\ d_{\mathcal{C}}\psi_{\alpha\beta} &= -\mathcal{L}_\gamma h_{\alpha\beta} = -(D_\alpha\gamma_\beta + D_\beta\gamma_\alpha) \\ d_{\mathcal{C}}\gamma^\alpha &= 0. \end{aligned} \quad (16.15)$$

This multiplet of fields is very popular and was used in [228,225], among other places.

The antighosts for the projection form are vector fields

$$\lambda^\alpha, \eta^\alpha \in \text{Lie } \mathcal{G} = \text{diff } (\Sigma) \quad (16.16)$$

of ghost numbers -2 and -1 , respectively. In the Cartan model the transformation laws are:

$$d_{\mathcal{C}}\lambda^\alpha = \eta^\alpha \quad d_{\mathcal{C}}\eta^\alpha = -\mathcal{L}_\gamma\lambda^\alpha. \quad (16.17)$$

16.2.3. Lagrangian

A. Localization Lagrangian

For the localization Lagrangian we introduce a scalar antighost ρ and its Lagrange multiplier π . Then the gauge fermion for localizing to $\text{MET}(\Sigma)_k$ is:

$$\Psi_{\text{weyl loc}} = \int d^2z \sqrt{h} \rho (R - k) \quad (16.18)$$

Using the following two relations:

$$\begin{aligned} Q\Gamma_{\beta\gamma}^\alpha &= \frac{1}{2}h^{\alpha\delta} (D_\beta Qh_{\gamma\delta} + D_\gamma Qh_{\beta\delta} - D_\delta Qh_{\beta\gamma}) \\ QR &= -\frac{1}{2}D_\alpha D^\alpha (h^{\gamma\beta} Qh_{\beta\gamma}) + D^\alpha D^\beta Qh_{\alpha\beta} - \frac{1}{2}R h^{\alpha\beta} Qh_{\alpha\beta} \end{aligned} \quad (16.19)$$

where $Q = d + d_{\mathcal{C}}$, we may write this action as

$$I_{\text{weyl loc}} = \int d^2z \sqrt{h} \{ \pi (R - k) - \rho L^{\alpha\beta} \psi_{\alpha\beta} \} \quad (16.20)$$

where

$$L^{\alpha\beta} = D^\alpha D^\beta - \frac{1}{2}h^{\alpha\beta}D^2 - \frac{1}{2}kh^{\alpha\beta} \quad (16.21)$$

B. Projection Lagrangian

The metric (16.6) is Diff invariant. Therefore we can directly transcribe the construction of chapter 14. For the projection Lagrangian we use the formulae in section 14.4.2 above. The operator C is

$$\begin{aligned} C: \gamma &\rightarrow \mathcal{L}_\gamma h_{\alpha\beta} \\ \gamma^\alpha &\rightarrow (P\gamma)_{\alpha\beta} = D_{(\alpha}\gamma_{\beta)} \end{aligned} \quad (16.22)$$

so that the operator C^\dagger is

$$\begin{aligned} C^\dagger: T_h \text{ MET} &= \Gamma(\text{Sym}(T^*\Sigma^{\otimes 2})) \rightarrow \text{Vect}(\Sigma) \\ C^\dagger &= P^\dagger \psi \end{aligned} \quad (16.23)$$

where the last expression represents C^\dagger in superspace.

Thus we take the gauge fermion:

$$\Psi_{\text{projection}} = i \int d^2z \sqrt{h} \{ \lambda^\alpha D^\beta \psi_{\alpha\beta} \} \quad (16.24)$$

with corresponding action

$$\begin{aligned} I_{\text{projection}} &= i \int d^2z \sqrt{h} \{ \lambda^\alpha [(D_\alpha \psi_{\beta\gamma}) \psi^{\beta\gamma} + (D_\beta \psi_{\alpha\gamma}) \psi^{\beta\gamma}] \\ &\quad - \lambda^\alpha (D^\beta D_\beta \gamma_\alpha + D^\beta D_\alpha \gamma_\beta) + \eta^\alpha D^\beta \psi_{\alpha\beta} \} \end{aligned} \quad (16.25)$$

The combined action $I_{\text{weyl loc}} + I_{\text{proj}}$ is still Diff invariant so that, just as in the case of Donaldson theory, it remains for us to fix the gauge symmetry. We fix the Diff symmetry as in (16.10), introducing the standard b and c ghosts. Altogether, the Lagrangian is

$$I_{\text{tot}} = I_{\text{weyl loc}} + I_{\text{projection}} + I_{\text{gauge-fixing}} \quad (16.26)$$

Remarks

1. This Lagrangian is not manifestly conformally invariant, although the $d_{\mathcal{C}}$ -invariance suggests it should have a conformally invariant quantization. It does, formally, have a cancelling conformal anomaly $52 - 52 = 0$ as it must by $d_{\mathcal{C}}$ -symmetry.
2. This formulation of 2D gravity is essentially that given in [132], eq. 4.8, and is closest to our general formulation in chapter 14. We will use it in formulating topological string theory and the YM_2 theory in the next two chapters.

16.3. Formulation 3: $\mathcal{G} = \text{Diff}(\Sigma) \times L.L.(\Sigma)$

Another formulation makes 2d topological gravity seem very similar to Donaldson theory. The physical fields in this formulation are the zweibeine, local sections of the frame bundle, $F \rightarrow \Sigma$, and the spin connection, an $SO(2)$ connection on F . We shall denote the space of zweibeine and spin connections by FRAME.

16.3.1. Equations

As before, we fix the Weyl symmetry by imposing a curvature constraint on the spin connection. In defining topological gravity, we must ensure that our connection is Riemannian, hence we must localize to the subspace of (e^a, ω_a^b) , which satisfy a set of torsion constraints in addition to the curvature constraint:

$$\mathcal{Z} = \{e^a, \omega_a^b \in \text{FRAME} \mid R_b^a = d\omega_b^a + \omega_c^a \omega_b^c = k\epsilon_b^a \text{ and } T^a = de^a + \omega_b^a e^b = 0\} \quad (16.27)$$

where $k = 0, \pm 1$, depending on the genus of Σ and $\epsilon = \begin{pmatrix} 0 & 1 \\ -1 & 0 \end{pmatrix}$. The obvious choice for \mathcal{V} is the trivial bundle $\mathcal{V} = \text{FRAME} \times \mathbb{R}^3$. The corresponding anti-ghosts and Lagrange multipliers are $r \in \Omega^0(\Sigma; so(2))$, $\rho_a \in \Omega^0(\text{FRAME}^*)$ and $p \in \Omega^0(\Sigma; so(2))$, $\pi_a \in \Omega^0(\text{FRAME}^*)$.

16.3.2. BRST Complex

Generators of the complex:

$$\begin{array}{ll} e^a \in \Omega^0(\text{FRAME}) & \psi^a = \tilde{d}e^a \in \Omega^1(\text{FRAME}) \\ \omega_a^b \in \Omega^0(\text{FRAME}, so(2)) & \psi_0^a{}^b = \tilde{d}\omega \in \Omega^1(\text{FRAME}, so(2)) \\ c^\alpha \in \mathcal{W}^1(\text{diff}) & \gamma^\alpha \in \mathcal{W}^2(\text{diff}) \\ c_0^a{}^b \in \mathcal{W}^1(\text{local lorentz}) & \gamma_0^a{}^b \in \mathcal{W}^2(\text{local lorentz}) \end{array}$$

A. BRST Model

In the BRST model the differential is given by

$$\begin{aligned}
Q e^a &= \mathcal{L}_c e^a - (e \cdot c_0)^a + \psi^a, \\
Q \psi^a &= \mathcal{L}_c \psi^a + (e \cdot \gamma_0)^a - \mathcal{L}_\gamma e^a - (\psi \cdot c_0)^a, \\
Q \omega_b^a &= i_c R_b^a - D c_0^a{}_b + \psi_0^a{}_b, \\
Q \psi_0^a{}_b &= i_c (D \psi_0)^a{}_b - [c_0, \psi_0]^a{}_b - i_\gamma R_b^a - D \gamma_0^a{}_b, \\
Q c^\alpha &= \frac{1}{2} \mathcal{L}_c c^\alpha + \gamma^\alpha, \\
Q \gamma^\alpha &= \mathcal{L}_c \gamma^\alpha, \\
Q c_0^a{}_b &= \frac{1}{2} i_c i_c R_b^a - \frac{1}{2} \{c_0, c_0\}^a{}_b + \gamma_0^a{}_b, \\
Q \gamma_0^a{}_b &= \frac{1}{2} i_c i_c (D \psi_0)^a{}_b + [c_0, \gamma_0]^a{}_b.
\end{aligned} \tag{16.28}$$

B. Cartan Model

As always the Cartan model is readily obtained from the BRST model by setting the gauge ghosts (in this case, the diff ghosts c^α and the local Lorentz ghosts c_0^a , to zero.)

$$\begin{aligned}
Q_C e^a &= \psi^a, \\
Q_C \psi^a &= (e \cdot \gamma_0)^a - \mathcal{L}_\gamma e^a, \\
Q_C \omega_b^a &= \psi_0^a{}_b, \\
Q_C \psi_0^a{}_b &= -i_\gamma R_b^a - D \gamma_0^a{}_b, \\
Q_C \gamma^\alpha &= 0, \\
Q_C \gamma_0^a{}_b &= 0.
\end{aligned} \tag{16.29}$$

16.3.3. Lagrangians

The only novel feature of this model is the localisation Lagrangian:

$$I_{\text{loc}} = Q \int d^2 z \sqrt{h} \{ r \epsilon^b{}_a (d\omega_b^a + \omega_c^a \omega_b^c - k \epsilon_b^a) + \rho_a (de^a + \omega_b^a e^b) \} \tag{16.30}$$

This is sometimes described as ‘‘Donaldson theory of the spin connection’’.

16.4. Formulation 4: $\mathcal{G} = \widehat{\text{Diff}}(\Sigma)$

This formulation is an illustration of the general remark of section 10.8. There we saw that \mathcal{G} -equivariant cohomology can be formulated as ordinary Lie algebra cohomology for a ‘‘supersymmetrized’’ Lie algebra. Thus we can approach the subject as an ordinary gauge theory, but for a supersymmetrized version of $\text{Diff}(\Sigma)$.

To begin, we localize to the space of constant curvature metrics using (16.18) and (16.20), but this time we gauge fix $h_{\alpha\beta}$ and $\psi_{\alpha\beta}$ to

$$h_{\alpha\beta} = e^\phi \delta_{\alpha\beta} \quad \psi_{\alpha\beta} = e^\phi \psi \delta_{\alpha\beta} \quad (16.31)$$

The gauge fixing introduces the b, c, β, γ ghost systems. The theory breaks up into two sectors: a b, c, β, γ and a “topological Liouville” sector. Both have twisted $N = 2$ supersymmetry. This formulation was discussed in [61].

16.5. Observables

Next we turn to the matter of observables. Further discussion of observables in topological gravity can be found in [25,223,201,27]

Let X be an orientable, d -dimensional Riemannian manifold and let F be the frame bundle. F is a principal $GL(d, \mathbb{R})$ bundle over X . Let \mathcal{A} be the space of connections on F . Two local symmetries act on $\mathcal{A} \times F$: (i) the diffeomorphisms of X , $\text{Diff}(X)$, and (ii) the local linear frame transformations, \mathcal{G} . We shall denote $\mathcal{H} = \mathcal{G} \times \text{Diff}(X)$. In contrast to the ordinary gauge theory case, the automorphisms of F that we need to consider here may be both horizontal (Diff) and vertical (\mathcal{G}). As in the case of Yang-Mills moduli space, the naive moduli spaces, \mathcal{A}/\mathcal{H} , are problematical. The resolution to (some of) these problems is to choose base points $x_1, \dots, x_n \in X$ at which we specify trivialisations, φ_i , of F . We then consider the $n + 1$ -tuples $(\omega; \varphi_1, \dots, \varphi_n)$, where ω is a spin connection of F , modded out by automorphisms (which now include diffeomorphisms) that act trivially at the base points. We shall denote $\mathcal{H}_0 = \{h \in \mathcal{H} \mid h(x_i) = (1, x_i), \forall i = 1, \dots, n\}$.

Then consider

$$\begin{array}{ccc} & \mathcal{A}^* \times F & \\ \swarrow \mathcal{H}_0 & & \searrow H_0 \\ \tilde{\mathcal{B}}^* \times F & & \mathcal{A}^* \times X \\ \searrow H_0 & \tilde{\mathcal{B}}^* \times X & \swarrow \mathcal{H}_0 \end{array} \quad (16.32)$$

where $H_0 = GL(d, \mathbb{R})/C(GL(d, \mathbb{R}))$ and where $\tilde{\mathcal{B}}^* = \tilde{\mathcal{A}}^*/\mathcal{H}_0$. So $\tilde{\mathcal{B}}^* \times F$ is a principal H_0 bundle over $\tilde{\mathcal{B}}^* \times X$:

$$\begin{array}{ccc} \tilde{\mathcal{B}}^* \times F & \leftarrow & H_0 \\ \downarrow & & \\ \tilde{\mathcal{B}}^* \times X & & \end{array} \quad (16.33)$$

Consider now the case of $d = 2$. Let $X = \Sigma_{h,n}$ be some Riemann surface of genus h with n marked points. Then we study the moduli spaces, $\mathcal{M}_{h,n}$ of stable genus h Riemann surfaces with n marked points. The Deligne-Mumford compactification of these moduli spaces will be denoted by $\bar{\mathcal{M}}_{h,n}$. There is the “forgetful” map $\beta_n: \bar{\mathcal{M}}_{h,n} \rightarrow \bar{\mathcal{M}}_{h,n-1}$ which forgets about the first trivialisation [223]. This map does not exist for certain low values of h and n (e.g. $(h,n) = (0,3)$ or $(h,n) = (1,1)$.)

We have a classifying map:

$$\Phi: \bar{\mathcal{M}}_{h,n} \times \Sigma_{h,n} \rightarrow BGL(2, \mathbb{R}) \quad (16.34)$$

which we may use to obtain cohomology classes $c \in H^d(\tilde{\mathcal{B}}^* \times X)$ from characteristic classes associated with the maximal compact subgroup $SO(2)$.

The cohomology classes on $\bar{\mathcal{M}}_{h,n}$ may be constructed in a manner similar to the case of topological Yang-Mills theory [25,223]:

1. There are the Mumford-Morita-Miller classes [157,155,143] which are constructed as follows: Consider the moduli space $\bar{\mathcal{M}}_{h,1}$. The location of the marked point at $x_1 \in X$, may be viewed as a section of the universal curve: $\bar{\mathcal{M}}_{h,1} \rightarrow \bar{\mathcal{M}}_{h,0}$. The cotangent along the fibre defines the relative cotangent bundle:

$$\begin{array}{c} \mathcal{L}_{(1)} = K_{C/\mathcal{M}} \\ \downarrow \\ \bar{\mathcal{M}}_{h,1} \end{array}$$

The first Chern class of $\mathcal{L}_{(1)}$ (and its powers) define a set of cohomology classes on $\bar{\mathcal{M}}_{h,1}$, which we may pushdown via the “forgetful” map: $\beta: \bar{\mathcal{M}}_{h,1} \rightarrow \bar{\mathcal{M}}_{h,0}$, which forgets about the first point. We then define

$$\kappa_n = \beta_*(c_1(\mathcal{L}_{(1)})^{n+1}) \quad (16.35)$$

The resulting objects are degree $2n$ cohomology classes on $\bar{\mathcal{M}}_{h,0}$.

2. There is a set of cohomology classes on $\bar{\mathcal{M}}_{h,n}$ which is very natural from the point of view of topological Yang-Mills theory. There is an obvious generalization of the line bundle $\mathcal{L}_{(1)}$ to a collection of line bundles $\mathcal{L}_{(i)} \rightarrow \bar{\mathcal{M}}_{h,n}$ for $i = 1, \dots, n$. Just as in the case of topological Yang-Mills theory, we define observables via the slant product pairing:

$$\begin{aligned} /: H_i(X) \times H^r(\bar{\mathcal{M}}_{h,n} \times X) &\rightarrow H^{r-i}(\bar{\mathcal{M}}_{h,n}) \\ \mathcal{O}_c [\alpha] &\mapsto c/[\alpha] \end{aligned}$$

In particular, for any $x_i \in \Sigma_{h,n}$, this yields the classes:

$$\sigma_n(x_i) = (c_1(\mathcal{L}_{(i)}))^n(x_i)$$

which live in $H^{2n+2}(\bar{\mathcal{M}}_{h,n})$.

16.6. Hamiltonian Approach

The Hamiltonian approach to the construction of operators in 2D gravity within the framework of equivariant cohomology has been discussed in [89]. The cohomology can be identified with S^1 -equivariant cohomology, and this continues to hold when coupled to matter. The result is somewhat surprising since one might well have expected to compute $\text{Diff}(S^1)$ -equivariant cohomology. Conceivably, we can replace $\text{Diff}(S^1) \rightarrow S^1$ in homotopy theory. (Many other papers, too numerous to list here, have examined 2D topological gravity from the canonical point of view.)

16.7. Correlation Functions

According to general principles we know that the correlation functions of the field theory will be related to intersection theory on moduli space by

$$\begin{aligned} \langle \prod_i \hat{\sigma}_{n_i} \rangle &= \int_{\mathcal{M}_{h,0}} \prod_i \sigma_{n_i} \chi(\text{cok} \nabla \bar{s}) \\ &= \int_{\mathcal{M}_{h,0}} \prod_i \sigma_{n_i} \end{aligned} \tag{16.36}$$

The second equality arises since, in 2d topological gravity, the appropriate operators have $\text{cok} \nabla \bar{s} = \{0\}$ for $h > 1$. This can be seen in different ways from the different formulations as follows:

Formulation 1: Here there are no equations, hence no section \bar{s} ! Thus it is trivially true that $\chi = 1$.

Formulation 2: Here we have

$$\mathbb{O} = \begin{pmatrix} L^{\alpha\beta} \psi_{\alpha\beta} \\ \nabla^\beta \psi_{\alpha\beta} \end{pmatrix} \tag{16.37}$$

where $L^{\alpha\beta}$ is defined in (16.21). It is well-known that P^\dagger has a trivial cokernel when the genus is greater than one. In other words, any vector field may be expressed as P^\dagger acting on a *traceless* quadratic differential. The question is now whether any function on Σ can be expressed via as $L^{\alpha\beta}$ acting on the trace part of a quadratic differential. From (16.21), it is apparent that the differential part of L does not act on the trace part of ψ . This leaves only the algebraic piece of L to act on it. This may be solved without obstruction for genus greater than one. It follows that

$$\ker \mathbb{O} \cong H^0(\Sigma; K^2) \quad \text{coker } \mathbb{O} \cong \{0\} \tag{16.38}$$

17. Topological string theory

17.1. Basic Data

We continue our examination of \mathcal{G} -equivariant cohomology for $\mathcal{G} = \text{Diff}(\Sigma)$, $\text{Diff}(\Sigma) \times \text{Weyl}(\Sigma)$, etc. A natural \mathcal{G} -space is the space of \mathcal{C}^∞ maps from a worldsheet Σ to a target X , $\text{MAP}(\Sigma, X)$, of chapter 13. We will take X to be compact and Kähler.⁵³ Thus, the fields in the theory will be pairs

$$\mathbb{F} = (h, f) \in \widetilde{\mathcal{M}} \equiv \text{MET} \times \text{MAP} \quad .$$

These are the fields of topological string theory[219,61,150].

17.2. Equations

The quotient space $\text{MAP} \times_{\mathcal{G}} \text{MET}$ is again infinite dimensional, and again we must localize on an interesting finite-dimensional subspace thereof. The space of holomorphic maps, $\mathcal{H}(\Sigma, X)$, is one very interesting subspace, and we will focus on this. We localize by the same section as in chapter 13: $s(h, f) = df + Jdf\epsilon(h)$. The complex structure on the worldsheet is related to the (conformal class of the) worldsheet metric, h , via $\epsilon_\alpha^\beta(h) = \sqrt{h}\hat{\epsilon}_{\alpha\gamma}h^{\gamma\beta}$, as in section 5.4. J is the complex structure of the target space, X . Note that, in contrast to the topological sigma model of chapter 13, in topological string theory, we allow the complex structure of Σ to vary.

Depending on how we formulate topological gravity we might also have equations for the metric $h_{\alpha\beta}$. To fix ideas we will use formulation 2 of chapter 16, hence the equations are the constant curvature equation $R[h] = -1$ (for genus > 1). $\widetilde{\mathcal{M}}_{-1}$ denotes the subspace of $\widetilde{\mathcal{M}}$ satisfying this equation. We also let $\widetilde{\mathcal{H}} = \{\mathbb{F} \in \widetilde{\mathcal{M}}_{-1} : s(\mathbb{F}) = 0\}$.

17.3. Antighost bundle

As in the topological sigma model (13.5) we can take: $\widetilde{\mathcal{V}} \rightarrow \widetilde{\mathcal{M}}$ whose fiber at f is given by:

$$\widetilde{\mathcal{V}}_f := \Gamma[T^*(\Sigma) \otimes f^*(TX)]^+$$

The superscript $+$ indicates the “self-duality” constraint $\rho \in \widetilde{\mathcal{V}}_f \leftrightarrow J \rho \epsilon = \rho$. Clearly this constraint introduces MET dependence to the fibre. Correspondingly the fibre metric, (13.7), varies in the metric directions.

⁵³ More generally, X can be almost Kähler. The formal construction of Lagrangians discussed in this paper works equally well for X noncompact. More work is required to formulate precisely the observables and correlators in the noncompact case.

17.4. Connection on antighost bundle

Referring back to the general discussion in chapter 14, we recall that there are two connections used to construct the Lagrangian of a topological field theory with local symmetry: $\nabla = \nabla_s \oplus \nabla_g$. In the case of topological string theory both connections are nontrivial. Essentially, the connection ∇_s is that used in the construction of the topological sigma model, while that for ∇_g follows from the $\text{Diff}(\Sigma)$ gauge symmetry.

The connection on $\tilde{\mathcal{V}}$ will be a $\text{diff}(\Sigma) \oplus \text{so}(V)$ connection. The $\text{so}(V)$ part of the connection can be deduced following the same reasoning as in section 13.4. The tangent space to $\mathcal{Z}(s)$, determined by the Gromov equation,

$$\mathcal{Z}(s) = \tilde{\mathcal{H}} = \{(h, f) \in \tilde{\mathcal{M}}_{-1} \mid s(h, f) = df + Jdf\epsilon(h) = 0\} \quad (17.1)$$

is defined by

$$T_{f,h}\tilde{\mathcal{H}} = \{(\delta f, \delta h) \mid D(\delta f) + JD(\delta f)\epsilon + Jdfk(\delta h) = 0\}. \quad (17.2)$$

where D is the pulled-back connection $(D_\alpha \delta f)^\mu = \partial_\alpha \delta f^\mu + \Gamma_{\kappa\lambda}^\mu \partial_\alpha f^\kappa \delta f^\lambda$ and where $k(\delta h)$ is the variation of the complex structure:

$$\delta \epsilon_\alpha^\beta = k(\delta h)_\alpha^\beta = -\epsilon_\alpha^\gamma (\widehat{d\tilde{h}})_\gamma^\beta$$

where $(\widehat{d\tilde{h}})_\alpha^\beta = (\delta_\alpha^\gamma h^{\beta\delta} - \frac{1}{2}\delta_\alpha^\beta h^{\gamma\delta})(\tilde{d\tilde{h}})_{\gamma\delta}$ is the traceless part of $\tilde{d\tilde{h}}$. Equation (17.2) suggests that we introduce an operator:

$$\mathbb{D}_{\tilde{\mathcal{V}}} \equiv D\chi + J(D\chi)\epsilon - Jdf\hat{\psi}\epsilon: T\tilde{\mathcal{M}} \rightarrow \tilde{\mathcal{V}}$$

where χ^μ represents 1-forms in $T^*\text{MAP}$ and ψ represent 1-forms in $T^*\text{MET}$. The circumflex over the ψ indicates projection to the traceless part. One easily checks that the same formulae (13.11) (with \tilde{d} now the exterior on $\tilde{\mathcal{M}}$) defines a connection $\nabla_{\tilde{\mathcal{V}}}$ on $\tilde{\mathcal{V}}$. Let $x_\alpha^\mu \in \Gamma(\tilde{\mathcal{V}})$ be a section of $\tilde{\mathcal{V}}$ over $\tilde{\mathcal{M}}$, then in local coordinates $\{f^\mu, h_{\alpha\beta}\}$ on $\tilde{\mathcal{M}}$, the covariant derivative of x_α^μ is given by

$$\nabla_{\tilde{\mathcal{V}}} x_\alpha^\mu = \tilde{d}x_\alpha^\mu - \Gamma_{\kappa\lambda}^\mu x_\alpha^\kappa \tilde{d}f^\lambda$$

where \tilde{d} is the exterior derivative on $\tilde{\mathcal{M}}$, and $\Gamma_{\kappa\lambda}^\mu$ is the Christoffel connection on X . Moreover, $\nabla_{\tilde{\mathcal{V}}}(s) = \mathbb{D}_{\tilde{\mathcal{V}}}$.

17.5. BRST Complex

We can think of the generators of the complex in terms of

$$\begin{aligned}
 \text{Fields :} & & \mathbb{F} &= \begin{pmatrix} f^\mu \\ h_{\alpha\beta} \end{pmatrix} \\
 \text{Ghosts :} & & \mathbb{G} &= \begin{pmatrix} \chi^\mu \\ \psi_{\alpha\beta} \end{pmatrix} \\
 \text{Antighosts :} & & & \rho^\alpha_\mu \\
 \text{Lagrange multipliers :} & & & \pi^\alpha_\mu
 \end{aligned}$$

The Cartan model differential for Diff acts as:

$$Q_C \begin{pmatrix} \mathbb{F} \\ \mathbb{G} \end{pmatrix} = \begin{pmatrix} 0 & 1 \\ -\mathcal{L}_\gamma & 0 \end{pmatrix} \begin{pmatrix} \mathbb{F} \\ \mathbb{G} \end{pmatrix} \quad Q_C \begin{pmatrix} \rho \\ \pi \end{pmatrix} = \begin{pmatrix} 0 & 1 \\ -\mathcal{L}_\gamma & 0 \end{pmatrix} \begin{pmatrix} \rho \\ \pi \end{pmatrix}$$

How we handle remaining ghosts/antighosts depends on how we represent 2D gravity. As mentioned above, we will choose formulation 2 of chapter 16.

17.6. Lagrangian

17.6.1. Localization

The localization $\widetilde{\mathcal{M}}_{-1} \hookrightarrow \widetilde{\mathcal{M}}$ eliminating the Weyl degrees of freedom proceeds exactly as in the discussion of 2D gravity in section 16.2. The localization $\widetilde{\mathcal{H}} \hookrightarrow \widetilde{\mathcal{M}}_{-1}$ proceeds as in chapter 13. Therefore the gauge fermion for localization is that of the topological sigma model:

$$\Psi_{\text{localization}} = \int d^2z \sqrt{h} \left\{ \rho^\alpha_\mu [is_\alpha^\mu - \frac{1}{4} \Gamma_{\kappa\lambda}^\mu \rho_\alpha^\kappa \chi^\lambda + \frac{1}{4} \pi_\alpha^\mu] \right\} \quad (17.3)$$

17.6.2. $\Psi_{\text{projection}}$

Next we turn to the gauge fermion for projecting out the gauge degrees of freedom. We follow the procedure of section 14.4, taking as gauge group just the diffeomorphism group. Thus, following the discussion of section 14.4.2, we replace $\phi \rightarrow \gamma^\alpha$. To find C we note that there is a canonical isomorphism between the Lie algebra $\text{diff}(\Sigma)$ of $\text{Diff}^+(\Sigma)$ and the vertical tangent space, $T^{\text{vert}}\widetilde{\mathcal{M}}_{-1}$, given by:

$$\begin{aligned}
 C: \text{diff}(\Sigma) &\rightarrow T^{\text{vert}}\widetilde{\mathcal{M}}_{-1} \\
 C_{(f,h)}: \gamma &\longmapsto \begin{pmatrix} \mathcal{L}_\gamma f \\ \mathcal{L}_\gamma h \end{pmatrix} = \begin{pmatrix} i_\gamma df \\ P\gamma, \end{pmatrix} \quad (17.4)
 \end{aligned}$$

where P is defined in (16.8) above. Thus we have $C^\dagger = D^\alpha \psi_{\alpha\beta} + \partial_\beta f^\mu \chi^\nu G_{\mu\nu}$.

To form the projection gauge fermion we introduce the antighosts λ^α and η^α of ghost numbers -2 and -1 , as in the previous chapter. The gauge fermion for projection in the gauge directions is (λ, C^\dagger) which in this case reads:

$$\Psi_{\text{projection}} = i \int d^2z \sqrt{h} \{ (P\lambda)^{\alpha\beta} \psi_{\alpha\beta} + i_\lambda df^\mu \chi^\nu G_{\mu\nu} \} \quad (17.5)$$

17.6.3. The Full Action

Combining all of the above gauge fermions, expanding out the Q actions and integrating out the Lagrange multipliers, we obtain the general action for coupling topological sigma models to topological gravity. As we have seen repeatedly, in formulating the correct intersection formula the key point is to examine the fermion kinetic term, which may be written in the compact form

$$(\rho \quad \eta) \mathbb{O} \mathbb{G} = \mathbf{A} \mathbb{O} \mathbb{G}, \quad (17.6)$$

where

$$\mathbb{O} = \begin{pmatrix} \mathcal{D} & Jdfk \\ \partial f & P^\dagger \end{pmatrix} : T_{f,h} \widetilde{\mathcal{M}}_{-1} \rightarrow \Gamma[T\Sigma \otimes f^*(TX)] \oplus \Gamma[T\Sigma]. \quad (17.7)$$

and the components are given by:

$$\begin{aligned} (\mathcal{D}\chi)_\alpha^\mu &= \nabla_\alpha \chi^\mu + J^\mu_\nu (\nabla_\beta \chi^\nu) \epsilon_\alpha^\beta \\ (\partial f \chi)_\alpha &= G_{\mu\nu} (\partial_\alpha f^\mu) \chi^\nu \\ [Jdfk(\psi)]_\alpha^\mu &= -J^\mu_\nu \partial_\gamma f^\nu \epsilon_\alpha^\beta \psi^\gamma_\beta \end{aligned} \quad (17.8)$$

17.7. Index

Although we do not have space to examine correlation functions in topological string theory we will give a formula for the most important quantity needed when considering correlators, namely, the index of \mathbb{O} .

Consider deformations $(\delta f, \delta h)$ in the kernel of \mathbb{O} . The first line of (17.7) ensures that $(\delta f, \delta h) \in T\widetilde{\mathcal{H}}$ and the second ensures that $(\delta f, \delta h) \notin T^{\text{vert}}\widetilde{\mathcal{H}}$. In conformal gauge the operator $\mathbb{O}: T\widetilde{\mathcal{M}}_{-1} \rightarrow \widetilde{\mathcal{V}} \oplus \text{diff}$ splits into the direct sum of two operators $O \oplus \bar{O}$, which are, of course, related by complex conjugation.

$$O = \begin{pmatrix} 2D_{\bar{z}} & -\partial_z f^w \\ \partial^z f_w & D^{\bar{z}} \end{pmatrix} \quad (17.9)$$

Consider the operators

$$O_0 = \begin{pmatrix} \mathcal{D} & 0 \\ 0 & P^\dagger \end{pmatrix} \quad \delta O = \begin{pmatrix} 0 & -\partial_z f^w \\ \partial^z f_w & 0 \end{pmatrix}$$

The operators O_0 and O share the same leading symbols and hence have equal indices. It is easily seen from the Hirzebruch-Riemann-Roch theorem (see section 13.8.2) that

$$\boxed{\text{ind } \mathbb{O} = (h-1)(3 - \dim X) + \int_{\Sigma_W} f^*(c_1(TX))} \quad (17.10)$$

In sufficiently high genus ($h \geq 2$), $\dim \ker O_0 = 3h - 3$, where the kernel is spanned by the holomorphic quadratic differentials $\left\{ \begin{pmatrix} 0 \\ \psi^{(m)} \end{pmatrix} \right\}_{m=1, \dots, 3h-3}$; furthermore, $\dim \text{coker } O_0 = 3h - 3 - B$, where the cokernel is spanned by $\left\{ \begin{pmatrix} \rho^{(a)} \\ 0 \end{pmatrix} \right\}_{a=1, \dots, 3h-3-B}$. Though the indices of O and O_0 are equal, their kernels and cokernels are markedly different, for $\partial_z f^w \neq 0$. In fact, O generically does not possess a cokernel.

17.8. Example: Riemann surface target

Adapting the general formula (17.10) above to the case of a Riemann surface target, $X = \Sigma_T$, we get:

$$\dim_{\mathbb{C}} \ker \mathbb{O} - \dim_{\mathbb{C}} \text{coker } \mathbb{O} = B = 2h - 2 - n(2p - 2)$$

which is the total branching number.

On the other hand, we have seen that the complex dimension of Hurwitz space is B . Since the

$$\begin{pmatrix} \chi \\ \psi \end{pmatrix}$$

zeromodes span the cotangent space to \mathcal{H} we see that $\dim_{\mathbb{C}} \text{coker } \mathbb{O} = 0$. The result $\dim_{\mathbb{C}} \mathcal{H} = B$ can also be seen from a generalisation of Kodaira-Spencer theory described in appendix A of [52]. In the generic case ($G, h > 2$), $\dim_{\mathbb{C}} \text{coker } \mathbb{O} = 0$. Thus, in strong contrast to the case at fixed metric we have a positive number of $(\chi \ \psi)$ zero modes.

18. YM_2 as a topological string theory

Let us return to the problem of part I of this review. The main conclusion there was that the $1/N$ expansion of the partition functions of YM_2 generate Euler characters of moduli spaces of holomorphic maps. We can now apply the machinery of topological field theory to find an action principle for the underlying string theory of YM_2 .

18.1. Extending the fieldspace

We are searching for a string theory whose connected partition function is

$$Z_{\text{string}} \sim \chi_{\text{orb}}(\mathcal{H}(\Sigma_W, \Sigma_T)) = \int_{\mathcal{H}(\Sigma_W, \Sigma_T)} \chi[T\mathcal{H}(\Sigma_W, \Sigma_T) \rightarrow \mathcal{H}(\Sigma_W, \Sigma_T)] \quad (18.1)$$

Clearly, in order to localize to $\mathcal{H}(\Sigma_W, \Sigma_T)$, we should introduce the basic fields of topological string theory

$$\mathbb{F} = \begin{pmatrix} f^\mu \\ h_{\alpha\beta} \end{pmatrix} \in \widetilde{\mathcal{M}}$$

together with the standard section $s(\mathbb{F}) = (df + Jdf\epsilon, R[h] + 1)$.

We must also produce the correct density on the moduli space $\mathcal{H}(\Sigma_W, \Sigma_T)$. As we have seen, this is given by the basic formula (14.39). In particular, for the partition function, the density on moduli space is $\chi(\text{cok } \nabla \bar{s}) = \chi(\ker \mathbb{O}/\mathcal{G})$. Recall from section 17.8 that, for the topological string theory describing holomorphic maps $\Sigma_W \rightarrow \Sigma_T$ we have a fermion kinetic operator \mathbb{O} satisfying:

$$\begin{aligned} \ker \mathbb{O}_{f,h} &\cong T_{f,h}\mathcal{Z}(s) \\ \text{cok } \mathbb{O}_{f,h} &= \{0\} \end{aligned} \quad (18.2)$$

In the usual way, $\ker \mathbb{O}$ is a $\text{Diff}(\Sigma_W)$ -equivariant bundle over $\mathcal{Z}(s)$, so that $\ker \mathbb{O}/\text{Diff}(\Sigma_W) \cong T_{[(f,h)]}\mathcal{H}$. ■

Evidently, one way to obtain the required density $\chi(T\mathcal{H} \rightarrow \mathcal{H})$ is to use the elementary fact that

$$\begin{aligned} \ker \mathbb{O}_{f,h}^\dagger &= \{0\} \\ \text{cok } \mathbb{O}_{f,h}^\dagger &\cong T_{f,h}\mathcal{Z}(s) \end{aligned} \quad (18.3)$$

so that, if the fermion kinetic operator were

$$\mathbb{O} \oplus \mathbb{O}^\dagger \quad (18.4)$$

then we would obtain the desired answer. Note that, since $\text{ind}(\mathbb{O} \oplus \mathbb{O}^\dagger) = 0$, no insertions of operators are necessary, the total ghost number anomaly is cancelled.

18.1.1. “Cofields”

In order to obtain (18.4) as the fermion kinetic operator, we must extend the field space relative to that of the standard topological string theory. The new fields are completely determined by the requirement that \mathbb{O}^\dagger maps ghosts to antighosts, and by Q -symmetry.

In describing the new fields it is easiest to begin with the “dual” set of ghosts $\widehat{\mathbf{G}}$. These take values in the domain of \mathbf{O}^\dagger and hence have the index structure:

$$\widehat{\mathbf{G}} = \begin{pmatrix} \hat{\chi}_\mu^\alpha \\ \hat{\psi}^\alpha \end{pmatrix} \quad (18.5)$$

or,

$$\widehat{\mathbf{G}} \in \Gamma(T\Sigma_W \otimes f^*(T^*\Sigma_T))^+ \oplus \Gamma(T\Sigma_W) \quad (18.6)$$

As for ρ_μ^α the selfduality constraint must be imposed, so

$$\hat{\chi}_w^z = 0 \quad (18.7)$$

Since the ghosts represent differential forms on fieldspace, (according to (11.32)), we must replace the original fieldspace $\widetilde{\mathcal{M}}$ of topological string theory by the total space of a vector bundle $\widehat{E} \rightarrow \widetilde{\mathcal{M}}$, where the fiber directions are spanned by fields

$$\widehat{\mathbf{F}} \in \Gamma(T\Sigma_W \otimes f^*(T^*\Sigma_T))^+ \oplus \Gamma(T\Sigma_W)$$

that is:

$$\widehat{\mathbf{F}} = \begin{pmatrix} \hat{f}_\nu^\alpha \\ \hat{h}^\alpha \end{pmatrix} \quad (18.8)$$

where $\hat{f}_w^z = 0$. We refer to the hatted fields as “cofields.”

18.2. Equations

Our choice of section will be

$$s : (\mathbf{F}, \widehat{\mathbf{F}}) \rightarrow (df + Jdf\epsilon, \mathbf{O}^\dagger \widehat{\mathbf{F}}) = (s_1, s_2) \quad (18.9)$$

and the zero set is just $\mathcal{Z}(s) = (\mathcal{Z}(s_1), 0)$ since \mathbf{O}^\dagger has no zero modes. The appropriate antighost bundle is therefore dual to $\widetilde{\mathcal{V}} \oplus \widetilde{\mathcal{V}}_{\text{cf}}$ where

$$\widetilde{\mathcal{V}}_{\text{cf}} = \Gamma(f^*(T\Sigma_T)) \oplus \Gamma(\text{Sym}(T\Sigma_W^{\otimes 2})) \quad . \quad (18.10)$$

In indices we have fields

$$\widehat{\mathbf{A}} = \begin{pmatrix} \hat{\rho}^\mu \\ \hat{\eta}_{\alpha\beta} \end{pmatrix} \quad . \quad (18.11)$$

The bundle $\widetilde{\mathcal{V}}_{\text{cf}}$ has a natural metric, and we may take the trivial connection on $\widetilde{\mathcal{V}}_{\text{cf}}$ plus the usual $\text{Diff}(\Sigma_W)$ connection.

18.3. BRST Complex

Since we use formulation 2 of 2D topological gravity we take the BRST complex of fields to be that given in section 17.5. Similarly, for the cofields we choose the Cartan model for Diff-equivariant cohomology:

$$Q \begin{pmatrix} \widehat{\mathbb{F}} \\ \widehat{\mathbb{G}} \end{pmatrix} = \begin{pmatrix} 0 & 1 \\ -\mathcal{L}_\gamma & 0 \end{pmatrix} \begin{pmatrix} \widehat{\mathbb{F}} \\ \widehat{\mathbb{G}} \end{pmatrix} \quad Q \begin{pmatrix} \widehat{\mathbb{A}} \\ \widehat{\mathbb{H}} \end{pmatrix} = \begin{pmatrix} 0 & 1 \\ -\mathcal{L}_\gamma & 0 \end{pmatrix} \begin{pmatrix} \widehat{\mathbb{A}} \\ \widehat{\mathbb{H}} \end{pmatrix}$$

The addition of the cofields does not change the Q -cohomology, so we expect to have the same observables as in topological string theory.

18.4. Lagrangian

The Lagrangian for the YM_2 string will be a sum of a Lagrangian for the topological string theory $\Sigma_W \rightarrow \Sigma_T$ plus a Lagrangian for localizing to $\widehat{\mathbb{F}} = 0$:

$$I_{YM_2} = I_{\text{top string}} + I_{\text{cofield}} \quad (18.12)$$

Following chapter 11 we write down the gauge fermion for the co-fields:

$$\begin{aligned} \Psi_{\text{cofield}} &= \langle \widehat{\mathbb{A}}, \mathbb{O}^\dagger \widehat{\mathbb{F}} \rangle - t(\widehat{\mathbb{A}}, \widehat{\mathbb{H}}) \\ &= \frac{1}{4\pi} \int d^2z \sqrt{h} \widehat{\mathbb{A}}^T (\mathbb{O}^\dagger \widehat{\mathbb{F}} - t\widehat{\mathbb{H}}) \end{aligned} \quad (18.13)$$

where

$$\mathbb{O}^\dagger = \begin{pmatrix} -(\delta_\mu^\nu \nabla_\gamma + J_\mu^\nu \nabla_\beta \epsilon^\beta_\gamma) & -G_{\mu\nu} \partial_\gamma f^\nu \\ -\delta^\alpha_\gamma J^\nu_\mu \partial_\delta f^\mu \epsilon^{\delta\beta} & \frac{1}{2}(\delta_\gamma^\alpha D^\beta + \delta_\gamma^\beta D^\alpha) \end{pmatrix} \quad (18.14)$$

18.5. Localization

With our choice of section, $s = (s_1, s_2)$ in (18.9), and connection, we can analyze (11.49) in this case. When restricted to the zeroset $\widehat{\mathbb{F}} = 0$ we find $\nabla s_2 = \tilde{d}s_2$ is a one-form with values in $\tilde{\mathcal{V}}_{\text{cf}}$ given by

$$\mathbb{O}^\dagger \begin{pmatrix} \chi \\ \psi \end{pmatrix} .$$

The analog of (11.49) in this case becomes:

$$0 \rightarrow \text{Im}(\mathbb{O} \oplus \mathbb{O}^\dagger) \rightarrow \tilde{\mathcal{V}} \oplus \tilde{\mathcal{V}}_{\text{cf}} \rightarrow \text{cok}(\mathbb{O} \oplus \mathbb{O}^\dagger) \rightarrow 0$$

as a sequence of bundles over \mathcal{H} .

By the general principles we have explained at length we see, by combining (18.2) and (18.4), with (14.65), that the path integral computes the Euler character of the cokernel (=obstruction) bundle, $T\mathcal{H}(\Sigma_W, \Sigma_T)$. Therefore, the Lagrangian (18.12) solves problem β of 2.2.1 for chiral YM_2 .

18.6. Nonchiral case

The nonchiral analog of the theory of sec. 18.4 must localize on both the space of holomorphic *and* antiholomorphic maps.⁵⁴ When we regard the topological string path integral as an infinite dimensional version of an equivariant Thom class it becomes clear that we need a section \tilde{w} of some bundle which localizes on the submanifolds $\tilde{\mathcal{H}}^\pm$ of $\tilde{\mathcal{M}}$ defined by $df \pm Jdf\epsilon = 0$. It is therefore natural to choose a section of the form:

$$\tilde{w}(f, h) \mapsto \dot{F} = [df + Jdf\epsilon] \otimes [df - Jdf\epsilon] \quad (18.15)$$

which has the index structure $\dot{F}_{\alpha\beta}^{\mu\nu}$. We have fields, ghosts, antighosts, and Lagrange multipliers:

$$\begin{aligned} \mathbb{F} &= \begin{pmatrix} f^\mu \\ h_{\alpha\beta} \end{pmatrix} & \mathbb{G} &= \begin{pmatrix} \chi^\mu \\ \psi_{\alpha\beta} \end{pmatrix} \\ A &= \rho_{\alpha\beta}^{\mu\nu} & \Pi &= \pi_{\alpha\beta}^{\mu\nu}. \end{aligned}$$

Only the anti-ghosts and Lagrange multipliers of the sigma model have changed relative to the chiral theory. In particular, the appropriate bundle for the antighosts ρ has fiber:

$$\tilde{\mathcal{V}}_{(f,h)}^{nc} = \Gamma[(T^*\Sigma_W)^{\otimes 2} \otimes (f^*(T\Sigma_T))^{\otimes 2}]_{\pm} \quad (18.16)$$

where the subscript \pm indicates that the sections must satisfy ‘‘self-duality’’ constraints:

$$\rho \in \tilde{\mathcal{V}}_{(f,h)}^{nc} \iff \begin{cases} \rho - (J \otimes \mathbf{1}) \rho (\epsilon \otimes \mathbf{1}) = 0 \\ \rho + (\mathbf{1} \otimes J) \rho (\mathbf{1} \otimes \epsilon) = 0 \end{cases} \quad (18.17)$$

The BRST transformations are the same as above. The nonchiral theory has an action

$$I_{\text{YM}_2\text{string}} = I_{\text{tg}} + I_{\text{t}\sigma}^{nc} + I_{\text{cofield}}^{nc} \quad (18.18)$$

The gravity part of the action is the same as before. The topological sigma model part is

$$I_{\text{t}\sigma}^{nc} = Q \int d^2z \sqrt{h} \left\{ \rho_{\mu\nu}^{\alpha\beta} [i\dot{F}_{\alpha\beta}^{\mu\nu} - \Gamma_{\lambda\rho}^\mu \chi^\lambda \rho_{\alpha\beta}^{\rho\nu} - \Gamma_{\lambda\rho}^\nu \chi^\lambda \rho_{\alpha\beta}^{\mu\rho} + \frac{1}{2}\pi_{\alpha\beta}^{\mu\nu}] \right\} \quad (18.19)$$

where the indices on ρ, π are raised and lowered with the metrics on the worldsheet (h), and target space (G).

⁵⁴ Some of the text in this section has been cut and pasted from [52].

If we expand (18.19) and integrate out the Lagrange multiplier then the bosonic term becomes (in local conformal coordinates)

$$I_{t\sigma}^{nc} = \int h^{z\bar{z}} G_{w\bar{w}}^2 |\partial_z f^w|^2 |\partial_{\bar{z}} f^w|^2 + \dots \quad (18.20)$$

thus clearly localizing on both holomorphic and antiholomorphic maps. Moreover, when we work out the quadratic terms in the fermions we find that many components of ρ do not enter the Lagrangian. These components are eliminated by the constraints (18.17). In locally conformal coordinates the only non-trivial components of $\rho \in \tilde{\mathcal{V}}_{(f,h)}^{nc}$ are $\rho_{z\bar{z}}^{\bar{w}w}$, $\rho_{z\bar{z}}^{\bar{w}\bar{w}}$, $\rho_{z\bar{z}}^{ww}$, and $\rho_{z\bar{z}}^{w\bar{w}}$. (Note that $\rho_{\alpha\beta}^{\mu\nu}$ is not symmetric in interchanging $\{(\alpha\beta)(\mu\nu)\} \leftrightarrow \{(\beta\alpha)(\nu\mu)\}$). The kinetic term for the fermions is given by

$$I_{t\sigma}^{nc} = i \int d^2z \sqrt{h} (\rho \quad \eta) \mathbb{O}^{nc} \begin{pmatrix} \chi \\ \psi \end{pmatrix} + \dots \quad (18.21)$$

where \mathbb{O}_{nc} is a 2×2 matrix operator with entries:

$$\begin{aligned} \mathbb{O}_{11}^{nc} &= \mathcal{D}^+ \otimes [df - Jdf\epsilon] + [df + Jdf\epsilon] \otimes \mathcal{D}^- \\ \mathbb{O}_{12}^{nc} &= J df k \otimes [df - Jdf\epsilon] - [df + Jdf\epsilon] \otimes J df k \\ \mathbb{O}_{21}^{nc} &= \partial f \\ \mathbb{O}_{22}^{nc} &= P^\dagger \end{aligned} \quad (18.22)$$

Here $\mathcal{D}^\pm \chi^\mu = D\chi^\mu \pm J(D\chi^\mu)\epsilon$ and, as usual, $k[\delta h]$ is the variation of the complex structure on Σ_W induced from a variation of the metric δh .

The co-model is introduced using the same principles as before. The contact terms have not been carefully analyzed in this nonchiral theory. They should be interesting. Heuristically the contributions of coupled maps can be pictured as boundary contributions. For further discussion see [52].

18.7. Perturbing by the area

In order to formulate a string picture of the physical phase of YM_2 we must perturb by the area operator:

$$I_0 \longrightarrow I_0 + \frac{1}{2} \int \mathcal{A}^{(2)}. \quad (18.23)$$

Here $\mathcal{A}^{(2)}$ fits into the area operator descent multiplet:

$$\begin{aligned} \mathcal{A}^{(0)} &= \sigma_0(\omega_{ij}(f(x))\chi^i\chi^j) \\ \mathcal{A}^{(1)} &= \sigma_0(dx^\alpha\omega_{ij}(f(x))\partial_\alpha f^i\chi^j) \\ \mathcal{A}^{(2)} &= \sigma_0(dx^\alpha \wedge dx^\beta\omega_{ij}(f(x))\partial_\alpha f^i\partial_\beta f^j), \end{aligned} \quad (18.24)$$

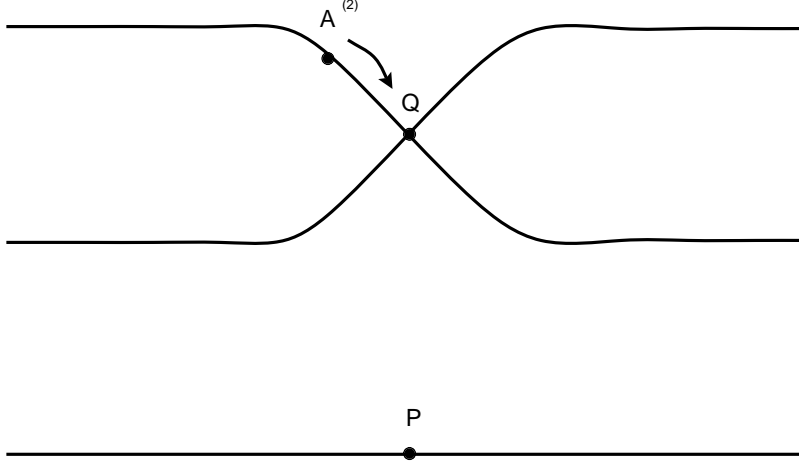

Fig. 37: An area operator collides with a 4 fermi curvature operator.

where ω is the Kähler two-form from the target space. Naively, the contribution of $\frac{1}{2} \int \mathcal{A}^{(2)}$ in a path integral over maps f of index n is $e^{-\frac{1}{2}nA}$. This accounts nicely for the exponential factors in (6.21) but fails to account for the polynomial dependence on A , $Z_{n,h,p}$ of (6.21). The latter may be accounted for by contact interactions between area operators and the curvature operators, illustrated in fig. 37.

An analysis of contact terms modelled on that used in [209] leads to recursion relations of the form:

$$\begin{aligned}
& \langle\langle \overbrace{\mathcal{A}^{(0)} \dots \mathcal{A}^{(0)}}^{B-r} \overbrace{\mathcal{A}^{(2)} \dots \mathcal{A}^{(2)}}^k \rangle\rangle_{\mathcal{H}(B,k;r)} \\
&= nA \langle\langle \overbrace{\mathcal{A}^{(0)} \dots \mathcal{A}^{(0)}}^{B-r} \overbrace{\mathcal{A}^{(2)} \dots \mathcal{A}^{(2)}}^{k-1} \rangle\rangle_{\mathcal{H}(B,k-1;r)} \\
&\quad - 2r \langle\langle \overbrace{\mathcal{A}^{(0)} \dots \mathcal{A}^{(0)}}^{B-r+1} \overbrace{\mathcal{A}^{(2)} \dots \mathcal{A}^{(2)}}^{k-1} \rangle\rangle_{\mathcal{H}(B,k-1;r-1)}
\end{aligned} \tag{18.25}$$

The subscripts refer to a stratification of Hurwitz space described in [52]. The first term represents the bulk contribution. In the second term there is one extra insertion of $\mathcal{A}^{(0)}$ which has replaced a curvature operator at a ramification point, and there is one fewer $\mathcal{A}^{(2)}$ operator. The coefficient r in the second term comes from the fact that for each area integral there are r collisions with curvature insertions at ramification points. The factor of -2 comes from the normalization of the contact term. From (18.25) one can derive the area polynomial associated with the portion of Hurwitz space corresponding to simple branched covers [52].

18.8. Horava's Theory

In [107] P. Horava made an independent and apparently different proposal for a topological string theory underlying YM_2 . As in the above discussion he begins by trying to reproduce the $A = 0$ theory of YM_2 . The $A \neq 0$ will be obtained as a perturbation by a BRST invariant operator.

Horava begins with a matter sector generalizing the topological sigma model. Instead of localizing onto holomorphic maps his matter localizes onto *harmonic maps* $\Sigma_W \rightarrow \Sigma_T$. This theory is then coupled to 2D topological gravity. It is argued in [107] that the resulting theory localizes on the space of *minimal area maps*.

It would be very interesting to develop the proposal in [107] further. We have seen that the *chiral* theory of YM_2 involves holomorphic maps in a very natural way. On the other hand, the *nonchiral* theory involves the “degenerated coupled covers” of [52]. These are maps which are holomorphic or antiholomorphic on different components of the normalized curve Σ_W . Perhaps an approach using minimal area maps would lead to a more natural description of the degenerated coupled covers. It is curious that both the nonchiral theory (18.18) and Horava's theory involve higher numbers of derivatives than two.

19. Euler character theories

In the standard topological theories one localizes to an interesting moduli subspace, and computes intersection numbers within that subspace. It is also of interest to find a theory which calculates the Euler character of the moduli space $\mathcal{Z}(s)$ itself. The “cofield construction” of the previous chapter can be generalized. Whenever a topological theory has $\text{cok} \nabla \bar{s} = \text{cok } \mathbb{O} = \{0\}$ we can introduce a second set of fields with fermion kinetic operator \mathbb{O}^\dagger , by reversing the roles of the ghosts and the antighosts. As in the previous chapter, the change of operator $\mathbb{O} \rightarrow \mathbb{O}^\dagger$ involves adding new fields: $(\widehat{\mathbb{F}}, \widehat{\mathbb{G}}, \widehat{\mathbb{H}}, \widehat{\mathbb{A}})$. In the context of Witten's fields/equations/symmetries paradigm the new “cofield” multiplet $(\widehat{\mathbb{F}}, \widehat{\mathbb{G}})$ has the “quantum numbers of the equations,” (and of the Lie algebra, in the presence of gauge symmetry), while the antighosts $\widehat{\mathbb{A}}$ have the “quantum numbers of the fields.”

Recently, C. Vafa and E. Witten have applied the cofield construction to explain how the partition function of a topological twisting of D=4, N=4 supersymmetric Yang-Mills theory computes Euler characters of the moduli spaces of ASD instantons [207]. In the notation of [207], one begins with a topological field theory with BRST field multiplets (u^i, ψ^i) (i running over a set of coordinates for field space), equation antighost multiplets

(ρ^a, π^a) , (a running over a basis for the fiber of \mathcal{V}), and projection antighost multiplets (λ^x, η^x) , (x running over a basis for the Lie algebra of the gauge symmetry group). The fermion kinetic term of the original topological model is given by:

$$(\rho^a \quad \eta^x) \begin{pmatrix} \nabla^s \\ C^\dagger \end{pmatrix} = \langle (\rho^a \quad \eta^x), \mathbb{O}\psi \rangle = (\rho^a \quad \eta^x) \begin{pmatrix} D_{ai} \\ D_{xi} \end{pmatrix} \psi^i \quad (19.1)$$

where the D 's differential operators. One then adds fields such that BRST symmetry is preserved and the new fermions have kinetic operator \mathbb{O}^\dagger . Thus the ‘‘cofields’’ have indices:

$$\widehat{\mathbb{F}} = \begin{pmatrix} \hat{u}^a \\ \hat{u}^x \end{pmatrix} \quad (19.2)$$

and so forth.

It is pointed out in [207] that, quite generally, the cofield construction involves *two* BRST charges and there is an underlying $sl(2)$ symmetry in the construction. Indeed the fields and cofields fit together according to:

$$\begin{array}{ccccccc}
 & & & & & & \phi^x \\
 & & & & & & \searrow \\
 2 & & & & & & \\
 & & & & & & \hat{\psi}^x \\
 1 & & \psi^i & & \hat{\psi}^a & & \nearrow \\
 & \nearrow & & \searrow & & \nearrow & \\
 0 & u^i & & \hat{\pi}^i & \hat{u}^a & \pi^a & \hat{u}^x \\
 & \searrow & & \nearrow & \searrow & \nearrow & \searrow \\
 -1 & & \hat{\rho}^i & & \rho^a & & \eta^x \\
 & & & & & & \nearrow \\
 -2 & & & & & & \lambda^x
 \end{array} \quad (19.3)$$

Where \nearrow indicates action of Q , and \searrow the action of the second symmetry Q' . ϕ^x is the generator of the polynomials on the Lie algebra of the gauge symmetry, as appropriate to the Cartan model of equivariant cohomology.

Remarks

1. As opposed to the YM_2 example, the crucial vanishing theorem for $\ker \mathbb{O}^\dagger$ can fail for twisted $N = 4, D = 4$ SYM. This necessitates the choice of a more elaborate section $s(\mathbb{F}, \widehat{\mathbb{F}})$ in [207].
2. The presence of two topological charges Q and Q' and of the underlying $sl(2)$ symmetry is related to the original $N = 4$ supersymmetry in the Yang-Mills case. It can be shown that the chiral YM_2 string is similarly related to a topological string arising from an $N = 4$ string [59].
3. Another construction of Euler character theories appears in the work of Blau and Thompson [39].

20. Four Dimensions: A Conjecture

The original motivation for the program of Gross described in section 2.2 was to find a string interpretation of YM_4 . Gross proposed that, once YM_2 was interpreted as a string theory that theory, suitably generalized to four-dimensional targets, might be the string theory of YM_4 . In closing, let us describe a somewhat refined version of Gross' conjecture.

Interestingly enough, the string theory of YM_2 *does* have a natural extension to four-dimensional target spaces, these are the ‘‘Euler sigma models’’ $\mathcal{E}\sigma(X)$. They are obtained by applying the ‘‘cofield construction’’ of chapter 19 to the topological string associated to a target space X which is compact and Kähler.⁵⁵ If f is a holomorphic map we may generalize the degree of the map by choosing a basis e^α of $H_2(X, \mathbb{Z})$ and writing $f(\Sigma) = \sum d_\alpha e^\alpha \in H_2(X, \mathbb{Z})$. In analogy with $A > 0$ in YM_2 , the sum over the degrees may be regulated by perturbing the theory by $\Delta I = t^\alpha \int f^* \omega_\alpha$ where ω_α is Poincaré dual to e^α . By analogy with two dimensions we may expect that the partition function of $\mathcal{E}\sigma(X)$ should have the form:

$$Z = \sum_x N^x \sum_{d_\alpha \geq 0} \prod_\alpha e^{-t^\alpha d_\alpha} P_{d_\alpha}(t^\alpha) \chi_{\text{orb}}(\mathcal{CH}(\Sigma_W, X; d_\alpha)) \quad (20.1)$$

where experience from YM_2 suggests that we must allow Σ_W to be singular and we must allow ‘‘coupled maps’’ which are holomorphic and anti-holomorphic on different components of the normalization of Σ_W . By analogy we conjecture that $P_{d_\alpha}(t^\alpha)$ is a polynomial whose value at zero is one.

The natural question then arises: what is the spacetime physics of $\mathcal{E}\sigma(X)$? Experience with known topological string theories strongly suggests that the spacetime physics should be that of a 4-dimensional topological field theory, or an almost topological field theory, which depends on the choice of a Kähler class. We do not expect it to describe ordinary Yang-Mills theory.

Thinking back to the case of $D = 2$ we may recall that at large N , Donaldson theory and ‘‘physical’’ YM_2 are the same. We may then take a leap and guess that the correct relation which generalizes to $D = 4$ is the relation between $\mathcal{E}\sigma(X)$ and topological Yang-Mills theory on X . This would mean, for example, that, in analogy to (15.65) the large N asymptotics of the intersection number generator on instanton moduli space:

$$\left\langle e^{r^\alpha \mathcal{O}_2^{(2)}(e_\alpha)} \right\rangle_{\mathcal{M}_+(X; SU(N))} \quad (20.2)$$

would be closely related to the series (20.1) with $g_{\text{string}} = 1/N$ with some transformation between t^α and r^α .

⁵⁵ As noted in chapter 17, as wider class of target spaces can be considered.

21. Conclusion

It is all true. Or it ought to be; and more and better besides.

- *Winston Churchill*

Acknowledgements

We would like to thank M. Henningson, M. Marino, R. Plesser, R. Stora, W. Taylor and R. von Unge for remarks on preliminary drafts of this paper. Many students at the Les Houches school also made useful comments on the notes. We would also like to thank V.I. Arnold, S. Axelrod, T. Banks, M. Bershadsky, M. Douglas, S. Cecotti, R. Dijkgraaf, I. Frenkel, E. Getzler, D. Gross, M. Guest, J. Harris, K. Intriligator, M. Khovanov, V. Kazakov, I. Kostov, H. Ooguri, R. Plesser, R. Rudd, V. Sadov, J. Segert, S. Shenker, R. Stora, W. Taylor, C. Vafa, and G. Zuckerman for discussions and correspondence. S.C. thanks the department of physics at Harvard University for hospitality. G. M. thanks the department of physics at Rutgers University for hospitality while part of these lectures were being written. He also thanks L. Alvarez-Gaumé and E. Verlinde for their hospitality at CERN. Finally G.M. thanks R. Dijkgraaf and I. Klebanov for the opportunity to present some of this material at the 1994 Trieste Spring school and he thanks F. David and P. Ginsparg for the opportunity to present some of this material at the 1994 Les Houches school on fluctuating geometries. This work is supported by DOE grant DE-AC02-76ER03075, DOE grant DE-FG02-92ER25121, and by a Presidential Young Investigator Award.

Appendix A. Background from Differential Geometry

We begin by reviewing some important background material on the theory of bundles and connections on bundles. This is intended for lightning-review and for establishing notation. More leisurely treatments can be found in[34,49,76,57,113,199,4,125].

A.1. Differential forms

We assume a knowledge of metrics, differential forms, tangent vectors etc. In particular we assume a knowledge of the exterior differential d

$$\begin{aligned} \dots \xrightarrow{d} \Omega^k \xrightarrow{d} \Omega^{k+1} \xrightarrow{d} \dots \\ d^2 = 0 \end{aligned} \tag{A.1}$$

Moreover, given a vector field ξ there are two natural operations on forms

$$\begin{aligned} \iota_\xi : \Omega^k &\longrightarrow \Omega^{k-1} \\ \mathcal{L}_\xi : \Omega^k &\longrightarrow \Omega^k \end{aligned} \tag{A.2}$$

These satisfy the basic relation: $\mathcal{L}_\xi = [d, \iota_\xi]_+$.

A.1.1. Hodge dual

Given a metric define $*$: $\Omega^k(M) \rightarrow \Omega^{n-k}(M)$ as follows. Let $\epsilon_{\mu_1 \dots \mu_n} = \pm 1$ be the signature of the permutation. In a local coordinate basis take:

$$*(dx^{\mu_1} \wedge \dots \wedge dx^{\mu_p}) \equiv \frac{\sqrt{|\det g|}}{(n-p)!} \epsilon^{\mu_1 \dots \mu_p \mu_{p+1} \dots \mu_n} dx^{\mu_{p+1}} \wedge \dots \wedge dx^{\mu_n}.$$

Two key properties of $*$ are:

1. $*^2 = \frac{|\det g|}{\det g} (-1)^{p(n-p)}$ on $\Omega^p(M)$
2. $*$ defines an inner product on $\Omega^p(M)$: $\langle \alpha, \beta \rangle = \int \alpha \wedge *\beta$.

Exercise. Adjoint

Compute the adjoint of the exterior derivative

$$d^\dagger = (-1)^{n(p+1)+1} * d* \tag{A.3}$$

A.2. Bundles

A.2.1. Fiber Bundles

Locally a fiber bundle is a product space: $E = F \times B$. F is called the fiber, B the base, and E the total space. When the base is topologically nontrivial we can have “twisted” bundles:

Example 1: A band is a trivial bundle, $[0, 1] \times S^1$. The Möbius strip is a nontrivial bundle with $F = [0, 1]$.

Example 2: Consider the map of unit circles $S^1 \rightarrow S^1$ given by $z \rightarrow z^n$. This exhibits the unit circle as an n -fold covering of itself. We have a fiber bundle with discrete fiber $\mathbb{Z}/n\mathbb{Z}$. Compare $S^1 \times \mathbb{Z}_n$.

The formal definition is

Definition: A *fiber bundle*, E , with fiber F , over the basespace M is a topological space E with a continuous projection

$$\pi: E \rightarrow M$$

such that, $\forall x \in M \exists$ neighborhood U , $x \in U$ with a homeomorphism:

$$\Phi: U \times F \cong \pi^{-1}(U)$$

with $\pi(\Phi(x, f)) = x$.

The bundle is called a trivial bundle if it is globally a product space $E = F \times M$.

Definition: *Transition functions:* On overlaps $U_1 \cap U_2$, we have fiber-preserving functions, $\Phi_{12} = \Phi_2^{-1}\Phi_1: (U_1 \cap U_2) \times F \rightarrow (U_1 \cap U_2) \times F$ are the transition functions. They have the form $(x, f) \rightarrow (x, \Phi_{12}(x)(f))$ where $\Phi_{12}(x) \in \text{Diff}(F)$.

Exercise. *Cocycle condition*

Show that

- a. Φ_{ii} is the identity map.
- b. $\Phi_{ij}\Phi_{jk} = \Phi_{ik}$ on triple overlaps.

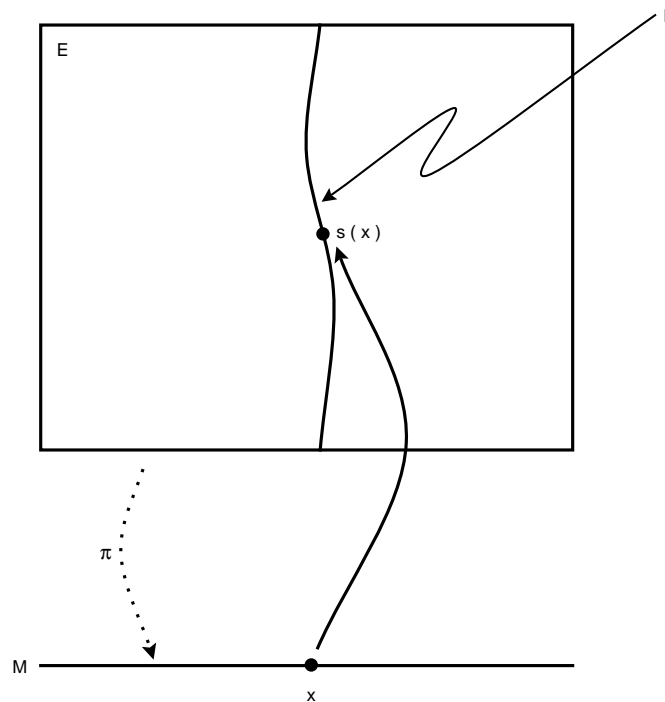

Fig. 38: Picture of a section

Definition: A *section* of E is a map $s: M \rightarrow E$, such that $\pi(s(x)) = x$. The picture is: s takes a point x to a point in the fiber above x as shown in fig. 38. If s is only defined locally it is called a local section.

A.2.2. Pulled back bundles

There are many formal constructions with bundles. One which will be often used is the pullback. If $f: B_1 \rightarrow B_2$ is a map, then given a bundle $\pi_2: E_2 \rightarrow B_2$ we can construct the pullback $f^*E_2 \rightarrow B_1$. This is the bundle over B_1 whose fiber at x is the fiber of E_2 over $f(x)$. The total space is just:

$$f^*E_2 = \{(p, x) \in E_2 \times B_1 \mid \pi_2(p) = f(x)\} \quad (\text{A.4})$$

and the projection $\pi: f^*E_2 \rightarrow B_1$ is $\pi(p, x) = x$.

Exercise.

What is the dimension of the total space of f^*E_2 ?

A.2.3. Vector Bundles

Definition: A vector bundle is a fiber bundle E where the fiber F is a *vector space* and the transition functions are *linear transformations*.

Exercise. Sections

Show that a vector bundle always has a canonical global section

The extra structure of a vector space opens the way for many new constructions. The basic point is that we can do all of linear algebra point by point and glue together globally. For example, we can carry out globally the basic definitions of direct sum, product, linear transformation and dual. Let E and F be any vector bundles. We can define:

$$\begin{aligned} (E \oplus F)_x &= E_x \oplus F_x \\ (E \otimes F)_x &= E_x \otimes F_x \\ \text{Hom}(E, F)_x &= \text{Hom}(E_x, F_x) \\ E_x^* &= \text{Hom}(E_x, \mathbb{R}) \end{aligned} \quad (\text{A.5})$$

Examples:

1. Trivial bundles $V \times M$. V a vector space.
2. Tangent space: $T_x M =$ vector space of directional derivatives. A coordinate system defines a natural basis: $\{\frac{\partial}{\partial x^\mu} \mid x\}$. Tangent bundle: $TM = \{(x, v) \mid v \in T_x M\}$. Explicitly a local section is

$$(x^\mu, v^\mu(x) \frac{\partial}{\partial x^\mu})$$

3. Cotangent bundle: $T_x^*M =$ dual space to T_xM . Explicitly a local section is

$$(x^\mu, \xi_\mu(x)dx^\mu)$$

4. Bundle of Differential j - forms. Let: $\Omega^j(M) = \Gamma[\Lambda^j T^*M]$. Local sections are:

$$(x^\mu, \xi_{\mu_1 \dots \mu_j}(x)dx^{\mu_1} \wedge \dots \wedge dx^{\mu_j})$$

5. If $E \rightarrow M$ is a vector bundle then $\Omega^k(M; E)$ denotes the space of k -forms on M with values in E : $\Omega^k(M; E) \equiv \Gamma(\Lambda^k(T^*M) \otimes E)$.

A.2.4. Principal Bundles

A *principal bundle* is a fiber bundle E , where the fiber F is a Lie group G and the transition functions are right-multiplication by elements of G . More formally:

Definition: A *principal G -bundle* for a Lie group G is a manifold P with a continuous projection $\pi : P \rightarrow M$ such that G acts smoothly and freely on the right on P and if s_U is a smooth section over U then

$$\Phi: U \times G \rightarrow \pi^{-1}(U)$$

$$\Phi: (x, g) \rightarrow s_U(x)g$$

is a diffeomorphism.

The transition functions across patch boundaries are local gauge transformations: $s_U(x)g_{UV}(x) = s_V(x)$, giving the local transition functions:

$$\Phi_U^{-1}\Phi_V(x, g) = (x, g_{UV}(x) \cdot g)$$

Exercise. *Cross sections*

Show that a principal bundle is trivial iff it has a global cross-section

Examples:

1. Consider the n -fold cover, $S^1 \rightarrow S^1$, above. This is a principal \mathbb{Z}_n bundle.
2. *Frame bundle:* The set of frames on TM form a principal $GL(n, \mathbb{R})$ bundle. Points are $(x; (e_1, \dots, e_n))$ where (e_1, \dots, e_n) is a linear basis for T_xM .
3. *Orthogonal frame bundle:* If M has a metric we can restrict the basis to an ON basis. Then we have a principal $O(N)$ bundle. If M is orientable, then we can further restrict to an oriented ON basis and we get an $SO(N)$ bundle.

4. *Homogeneous spaces* : $G =$ Lie group. $H =$ subgroup. $\pi : G \rightarrow G/H$ is a principal H bundle.
5. *The magnetic monopole bundle* : This is obtained from the homogeneous space bundle with $G = SU(2)$, $H = U(1)$, $G/H = S^2$.
6. *Instanton bundle* : Let $\mathbb{H} =$ quaternions, i.e., $\mathbb{H} = \{x_0 + i\vec{x} \cdot \vec{\sigma} = q \mid (x_0, \vec{x}) \in \mathbb{R}^4\}$. The unit quaternions form the group $SU(2)$. $S^7 =$ unit sphere in \mathbb{H}^2 . $\mathbb{H}P^1 = S^4$, and the quotient of the unit sphere by the unit quaternions gives the $SU(2)$ instanton bundle $S^7 \rightarrow S^4$.

A.2.5. Associated vector bundles.

Let V be in a representation ρ of G . Then consider the trivial bundle $P \times V$. This admits a G action:

$$g(p, v) = (p \cdot g^{-1}, \rho(g) \cdot v)$$

and the quotient by this G -action

$$\frac{P \times V}{G} \equiv P \times_G V$$

is a vector bundle over P/G with fiber V . This is called the *associated bundle* to P for the representation ρ .

Examples:

1. $\rho =$ the trivial representation. $P \times_G V = P/G \times V$.
2. $V = \mathbb{C}$, the basic representation of $U(1)$. $SU(2) \times_{U(1)} V$ is a complex line bundle over S^2 . Wavefunctions in the presence of a magnetic monopole will take values in this bundle.

Later we will use a basic tautology:

The sections $\Gamma(P \times_G V)$ may be naturally identified with the equivariant functions $f: P \rightarrow V$:

$$\Gamma(P \times_G V) = \text{MAP}_G(P \rightarrow V) \equiv \{f: P \rightarrow V \mid f(p \cdot g) = \rho(g^{-1})f(p)\} \quad (\text{A.6})$$

Exercise. From trivial bundles to associated bundles, and back

- a. Show that $P \times V \rightarrow P \times_G V$ is itself a principal G -bundle.
 - b. Show that the definition $P \times_G F$ extends to any space F with a left G -action. Show, moreover, that $P \times_G G = P$.
 - c. Show that if $\pi : P \rightarrow M$ is the projection, then the pullback bundle $\pi^*(P \times_G F) = P \times F$
-

A.3. Connections on Vector Bundles and Principal Bundles

A.3.1. Connections on Vector Bundles

Definition: A connection, ∇ , on a vector bundle E is a linear map

$$\nabla : \Gamma(E) \rightarrow \Omega^1(M; E) \quad (\text{A.7})$$

That is, if s is a section then ∇s is a one-form with values in the bundle. ∇ must satisfy:

$$\begin{aligned} \nabla(s_1 + s_2) &= \nabla s_1 + \nabla s_2 \\ \nabla(fs) &= s \otimes df + f\nabla s \end{aligned} \quad (\text{A.8})$$

where f is a function on M .

Remark: ∇ extends naturally to $\nabla : \Omega^k(M; E) \rightarrow \Omega^{k+1}(M; E)$

$$\begin{aligned} \nabla s(X_1, \dots, X_{p+1}) &= \sum_j (-1)^{j+1} \nabla_{X_j} s(X_1, \dots, \hat{X}_j, \dots, X_{p+1}) \\ &+ \sum_{i < j} (-1)^{i+j} s([X_i, X_j], \dots, \hat{X}_i \dots \hat{X}_j \dots), \end{aligned} \quad (\text{A.9})$$

where $\nabla_X = i_X \circ \nabla$. There are three immediate constructions obtained from a connection on E :

1. Covariant derivative: If s is a section, X a tangent vector, we can form the covariant derivative, $\nabla_X s$. In local coordinates it is given by:

$$(\nabla_X s)^\alpha = X^\mu \left(\partial_\mu s^\alpha + (A_\mu)^\alpha_\beta s^\beta \right)$$

where $(A_\mu(x))^\beta_\alpha dx^\mu$ is a one-form with values in $\text{End}(E_x)$.

2. Parallel transport: ∇_X is a covariant derivative. If $Z(\tau)$ is a path, $\dot{Z}(\tau)$ a tangent vector along the path, then

$$\nabla_{\dot{Z}(\tau)} s = 0 \quad (\text{A.10})$$

is a first order differential equation. This equation determines parallel transport, allowing us to “connect” different fibers. The solution to (A.10) in local coordinates reads:

$$s(\tau) = P \exp \left[- \int_0^\tau A \right] s(0) \quad (\text{A.11})$$

3. Horizontal tangent vectors

Recall that $TV = V \oplus V$ for a vector space V . Consider TE . At $(x, v) \in E$ there is a natural *vertical tangent space* along the fiber of E . In general there is no natural choice for a complementary subspace such that

$$T_e E = V_e \oplus H_e. \quad (\text{A.12})$$

Such a subspace is called a horizontal subspace.

A smooth choice of horizontal subspaces gives another way to define parallel transport of vectors. If a curve, γ , is in the base and $\pi(e(t)) = \gamma(t)$, then we may unambiguously define a lift of the tangent vector $\dot{\gamma}(t)$. Choosing an initial point $\tilde{\gamma}(0)$, we then define a lifted path $\tilde{\gamma}(t)$. Moreover, if we locally trivialize, so that the lifted path may be described by $\tilde{\gamma}(t) = (\gamma(t), s(t))$, then “ s is parallel transported” means that the tangent to $\tilde{\gamma}$ is

$$\dot{\gamma}^\mu(t) \frac{\partial}{\partial x^\mu} + \dot{s}^\alpha(t) \frac{\partial}{\partial v^\alpha} = \dot{\gamma}^\mu(t) \left[\frac{\partial}{\partial x^\mu} - (A_\mu)_\beta^\alpha v^\beta \frac{\partial}{\partial v^\alpha} \right]$$

Hence the horizontal subspace is given by:

$$H_{(x,v)} = \text{Span} \left\{ \frac{\partial}{\partial x^\mu} - (A_\mu)_\beta^\alpha v^\beta \frac{\partial}{\partial v^\alpha} \right\} \quad (\text{A.13})$$

A.3.2. Vertical Tangent Vectors on Principal Bundles

As preparation for discussing connections on principal bundles we first define the vertical vector fields. Let P be a principal bundle. Through any point $p \in P$, we define a right G -action: $R_p : G \rightarrow P$

$$R_p : g \mapsto p \cdot g \quad (\text{A.14})$$

embedding a copy of G inside P . The differential of this mapping

$$C_p = dR_p : \underline{\mathfrak{g}} \rightarrow T_p P \quad (\text{A.15})$$

defines tangent vectors to P for every element of the Lie algebra $X \in \underline{\mathfrak{g}}$. These are called the *fundamental vector fields* on P :

$$\forall X \in \underline{\mathfrak{g}} \quad \xi(X)_p = C_p(X) \quad (\text{A.16})$$

They are globally defined vector fields and $X \rightarrow \xi(X)$ is a homomorphism of Lie algebras:

$$[\xi(X), \xi(Y)] = \xi([X, Y]) \quad .$$

The image of C_p is called the *vertical tangent space at p* . A figure of a vertical tangent vector for a principal $U(1)$ bundle appears in fig. 34.

A.3.3. Connections on Principal Bundles

A connection on a principal bundle P is an equivariant splitting of the tangent space of P into horizontal and vertical vectors. Recall from section A.3.2 that there is a canonical vertical tangent space $(T_p P)^{\text{vert}} \cong \underline{\mathfrak{g}}$, given by the right G -action. Indeed, the differential defines an isomorphism:

$$C_p = dR_p : \underline{\mathfrak{g}} \cong (T_p P)^{\text{vert}} \quad (\text{A.17})$$

There is, in general, no natural way to find a complementary (=horizontal) subspace - a choice of horizontal subspace is called a connection. Formally, we have:

Definition A: A connection is a G -equivariant splitting of the tangent space TP into horizontal and vertical spaces, i.e., a choice

$$T_p P = H_p \oplus (T_p P)^{\text{vert}} \quad (\text{A.18})$$

such that

$$(R_g)_* H_p = H_{pg}. \quad (\text{A.19})$$

A more concrete way of defining the connection is to define its associated connection one-form:

Definition B. The connection form is a *globally defined* 1-form Θ with values in $\underline{\mathfrak{g}}$, i.e., $\Theta \in \Omega^1(P, \underline{\mathfrak{g}})$ such that

1. $\iota_{\xi(X)} \Theta = X$
2. $\mathcal{L}_{\xi(X)} \Theta = -\text{Ad}(X)\Theta = -[X, \Theta]$

Condition 2 can be exponentiated to give the right action of the group on Θ :

$$R_p^*(g)\Theta_p = \text{Ad}(g^{-1})\Theta = g^{-1}\Theta g \quad (\text{A.20})$$

Equivalence of Definitions A and B:

$A \Rightarrow B$: If $X_p \in T_p P$, then we have a splitting $X_p = X_p^{\text{hor}} + X_p^{\text{vert}}$. Define

$$\Theta_p(X_p) = C^{-1} \left[X_p^{\text{vert}} \right] \quad (\text{A.21})$$

Identifying $(T_p P)^{\text{vert}} \cong \underline{\mathfrak{g}}$ using the isomorphism in (A.17) shows that Θ is a Lie algebra-valued 1-form $\in \Omega^1(P; \underline{\mathfrak{g}})$.

$B \Rightarrow A$: $H_p = \ker \Theta$.

Examples:

1. Let G be a matrix group, $SU(N), SO(N), \dots$. Regard matrix elements of $g \in G$ as functions on G . Regard $G \rightarrow pt$ as a principal G -bundle. Then we can form the matrix of one-forms:

$$\Theta = g^{-1} dg \quad (\text{A.22})$$

One can easily check that this satisfies properties 1 and 2 of definition B. (A.22) is called the Maurer-Cartan form. It is the unique solution to these conditions for a Lie group.

2. Trivial bundle $G \times M$. A connection on a trivial bundle must look like:

$$\Theta_{(g,x)} = g^{-1} dg + g^{-1} A_\mu g dx^\mu \quad (\text{A.23})$$

where $A_\mu dx^\mu$ is a Lie-algebra-valued one-form on M , choosing a basis T_a for $\underline{\mathfrak{g}}$ we can write

$$A = A_\mu dx^\mu = A_\mu^a T_a \otimes dx^\mu \quad (\text{A.24})$$

3. Patch-by-patch. When the bundle is not trivial we can describe it by gluing together trivial bundles using transition functions. In a local trivialization

$$\begin{aligned} \Phi_U: U \times G &\rightarrow \pi^{-1}(U) \\ \Phi_U: (x, g) &\rightarrow s_U(x) \cdot g \end{aligned} \quad (\text{A.25})$$

we have

$$\Phi_U^*(\Theta) = g^{-1} dg + g^{-1} A_\mu^{(U)} g dx^\mu \quad (\text{A.26})$$

Θ is globally defined but will have different descriptions in different patches. Using the transition functions $s_U(x)g_{UV}(x) = s_V(x)$ we get:

$$\Phi_U^{-1}\Phi_V(x, g) = (x, g_{UV}(x) \cdot g)$$

We calculate:

$$\begin{aligned} g^{-1}dg + g^{-1}A^{(V)}g &= \Phi_V^*(\Theta) \\ &= (\Phi_U^{-1}\Phi_V)^*(g^{-1}dg + g^{-1}A^{(U)}g) \end{aligned} \tag{A.27}$$

Leading to the transformation law across patch boundaries:

$$A^{(V)} = g_{UV}^{-1}A^{(U)}g_{UV} + g_{UV}^{-1}dg_{UV}(x)$$

(A.28)

Exercise. Connections

Consider the principal H - bundle $G \rightarrow G/H$. Using an invariant metric define a natural connection.

A.3.4. Connection on an Associated Vector Bundle

A connection on a principal bundle induces a connection on an associated bundle $E = P \times_G V$. There are two ways to see this, corresponding to the two definitions above:

- A. We need to choose horizontal subspaces of the tangent space TE . Think of E as the basepace of the G - bundle $P \times V \rightarrow E$. The choice of connection of P defines a splitting of the tangent space $T_{(p,v)}(P \times V) = H_{p,v} \oplus \underline{\mathfrak{g}} \oplus V$. These horizontal subspaces descend to TE .
- B. Use the basic tautology (A.6) to identify $s \in \Gamma[E]$ with an equivariant function $f: P \rightarrow V$. Then ∇s corresponds to the equivariant 1-form: $\rho(\Theta) \cdot f$, where ρ is the representation of the Lie algebra.

In down-to-earth local coordinates, the associated bundle has a connection defining a covariant derivative: If s is a local section then

$$\nabla_Z s = Z^\mu (\partial_\mu (s(x))^\alpha + A_\mu^a(x) \rho(T_a)^\alpha_\beta s(x)^\beta) \tag{A.29}$$

which transforms across patch boundaries as

$$\nabla_Z s_U = \rho(g_{UV}) \cdot \nabla_Z s_V \tag{A.30}$$

A.4. Curvature and Holonomy

A.4.1. Holonomy

Now let $\gamma(\tau)$ be a path in M starting at x . If $P \rightarrow M$ is a principal bundle with connection then we can define the lifting of the vector fields $\dot{\gamma}$. We choose a point p over x and the lift is the horizontal vector field such that $d\pi\tilde{\gamma} = \dot{\gamma}$. The lifted curve $\tilde{\gamma}$ has this as tangent vector.

Now consider a closed curve γ . We have $\pi(\tilde{\gamma}) = \gamma$. The lifted curve need not be a closed curve, the endpoint of $\tilde{\gamma}$ need only lie in the same fiber above as the initial point. When $\tilde{\gamma}$ is not closed we have holonomy. For a principal bundle we can write

$$\tilde{\gamma}(1) = \tilde{\gamma}(0) \cdot h(p, \gamma) = p \cdot h(p, \gamma) \quad (\text{A.31})$$

for some group element $h(p, \gamma)$.

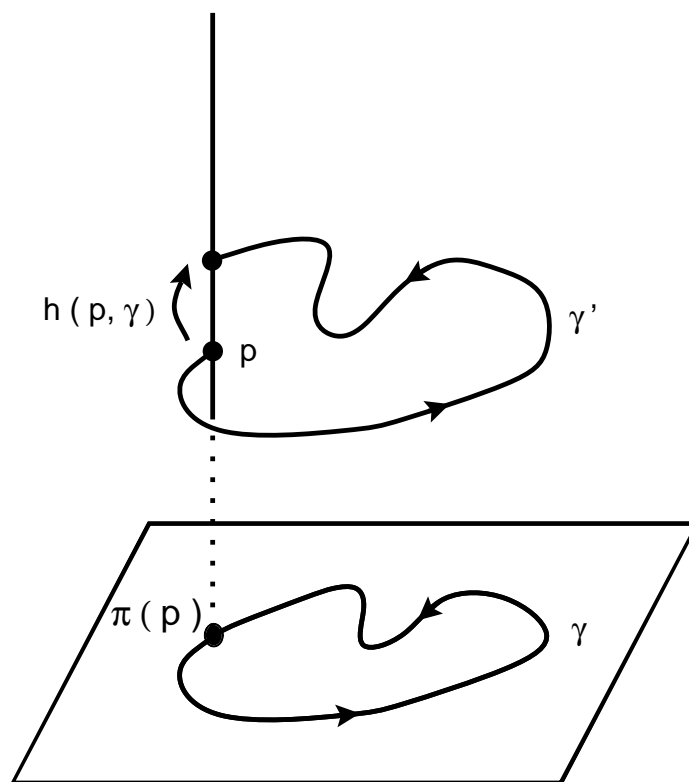

Fig. 39: Holonomy

Exercise. *Holonomy elements*

a. Show that

$$h(p, \gamma_1)h(h(p, \gamma_1), \gamma_2) = h(p, \gamma_1\gamma_2)$$

b.

$$h(pg, \gamma) = g^{-1}h(p, \gamma)g$$

Definition: The *holonomy group* $\mathcal{H}(p, \Theta)$ of the connection on P at p is the subgroup of G generated by $h(p, \gamma)$, for all closed curves $\gamma \in \Omega_x(M)$.

For an associated vector bundle we can also lift curves. In this case the holonomy is a multiplication of the initial vector by the group element in the appropriate representation. In a local patch we have:

$$\begin{aligned}\tilde{\gamma}(1) &= \tilde{\gamma}(0) P \exp \left[\oint A \right] \\ \tilde{v}(1) &= \rho \left(P \exp \left[- \oint A \right] \right) \tilde{v}(0).\end{aligned}\tag{A.32}$$

Examples:

1. $P = U(1) \times (\mathbb{R}^2 - \{0\})$, $A = iad\theta$, $h = \exp(2\pi ina)$. The holonomy group is \mathbb{Z} .
2. Consider the tangent bundle to the sphere S^2 with the round metric. The holonomy around a geodesic triangle is proportional to the area.

These two examples represent the two ways one can get holonomy: nontrivial π_1 and nontrivial curvature.

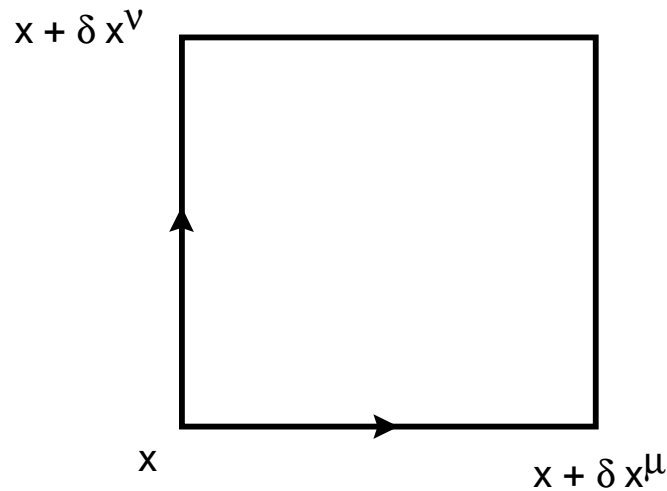

Fig. 40:

A.4.2. Curvature

Consider (A.32) for an infinitesimal loop surrounding an area element $\sigma^{\mu\nu} \partial_\mu \wedge \partial_\nu$ as in fig. 40. We can trivialize the bundle and introduce A . An elementary, but extremely

important calculation shows that the holonomy is

$$\begin{aligned} h(\gamma) &= 1 + \sigma^{\mu\nu} F_{\mu\nu} + \mathcal{O}(\sigma^2) \\ F_{\mu\nu} &= \partial_\mu A_\nu - \partial_\nu A_\mu + [A_\mu, A_\nu]. \end{aligned} \tag{A.33}$$

Formally we define the curvature of the connection to be

Definition The curvature of a connection Θ on P is

$$\mathbb{F} = d\Theta + \Theta^2 = d\Theta + \frac{1}{2}[\Theta, \Theta] \in \Omega^2(P; \mathfrak{g}). \tag{A.34}$$

One easily shows:

1. \mathbb{F} is horizontal $\iota_{\xi(X)}\mathbb{F} = 0$.
2. \mathbb{F} transforms in adjoint representation.

Indeed, in a local trivialization,

$$\begin{aligned} \mathbb{F} &= g^{-1} F_{\mu\nu}(x) g \, dx^\mu \wedge dx^\nu \\ &= (g^{-1} T_a g) F_{\mu\nu}^a(x) \, dx^\mu \wedge dx^\nu. \end{aligned} \tag{A.35}$$

Once again, by the basic tautology (A.6) we have

$$F \in \Omega^2(M; \text{Ad } P) \tag{A.36}$$

where $\text{Ad } P$ is the vector bundle associated to P by the adjoint representation.

Exercise. *Pure gauge*

Show that for the principal bundle $G \rightarrow pt$ the Maurer-Cartan form has curvature zero.

For the case of connections on vector bundles we have:

Definition: The curvature of a connection on a vector bundle $E \rightarrow M$ is the form in $\Omega^2(\text{End}(E))$ defined as follows. Let X, Y be tangent vectors to M . Then $F(X, Y) : \Gamma(E) \rightarrow \Gamma(E)$ is defined by

$$F(X, Y)s = \nabla_X(\nabla_Y s) - \nabla_Y(\nabla_X s) - \nabla_{[X, Y]}s.$$

When the vector bundle is associated to the principal bundle, then $F(X, Y) = \rho(F_{P.B.}(X, Y))$.

Exercise. *Curvature as the obstruction to a complex*

We saw above that $\nabla : \Omega^k(M; E) \rightarrow \Omega^{k+1}(M; E)$. Consider the sequence of spaces

$$\dots \xrightarrow{\nabla} \Omega^k(M; E) \xrightarrow{\nabla} \Omega^{k+1}(M; E) \xrightarrow{\nabla} \dots$$

Show that $\nabla^2 =$ multiplication by the curvature. The failure of ∇ to define a “complex” (e.g. a “BRST complex”) is measured by the curvature.

A.5. Yang-Mills equations and action

Let Σ_T be a spacetime of dimension n , $G_{\mu\nu}$ a metric on it. $P \rightarrow \Sigma_T$ a principal G bundle. Let $\mathcal{A}(P)$ be the space of all connections on P . This space is infinite-dimensional, and is the space of gauge fields in nonabelian gauge theory. We would like to write an action on $\mathcal{A}(P)$ which is gauge invariant.

To get an action consider $*F$. This is an $(n-2)$ -form with values in the Lie algebra. Let “Tr” be an invariant form on the Lie algebra – for example the ordinary trace in the fundamental representation for $SU(N)$. The gauge-invariant action is

$$\begin{aligned} I_{\text{YM}}[A] &= \frac{1}{4e^2} \int_{\Sigma_T} \text{Tr } \tilde{F} \wedge *F \\ &= \frac{1}{4e^2} \int_{\Sigma_T} d^D x \sqrt{\det G_{\mu\nu}} G^{\mu\lambda} G^{\nu\rho} \text{Tr } F_{\mu\nu} F_{\lambda\rho} \end{aligned} \tag{A.37}$$

The equations of motion and Bianchi identities are:

$$\begin{aligned} D_A F &= dF + [A, F] = 0 && \text{Bianchi identity} \\ D_A *F &= 0 && \text{Equations of motion.} \end{aligned} \tag{A.38}$$

In local coordinates (A.38) is:

$$\begin{aligned} D_{[\mu} F_{\nu\lambda]} &= 0 \\ D^\mu F_{\mu\nu} &= 0. \end{aligned} \tag{A.39}$$

Remarks:

1. (A.38) are a nonabelian generalization of the equations for a harmonic differential form: $d\omega = d*\omega = 0$.
2. D_μ involves the Levi-Civita connection of the metric.

Exercise. *Simple solutions*

Show that $A = \lambda U^{-1}(x) dU(x)$ solves the equations for $\lambda = 1/2, 1$. The first has infinite action (it is called a “meron”) and the second is pure gauge.

Exercise. Self-Duality

- a. Suppose $D = 4$. Show that either of the first order equations $F = \pm * F$ implies the Yang-Mills equations. These are called the (anti-) self dual equations.
- b. Show that the 't Hooft ansatz:

$$\begin{aligned} A_\mu &= i\bar{\Sigma}_{\mu\nu}\nabla^\nu \log f \\ f(x) &= 1 + \sum_{i=1}^N \frac{\rho_i^2}{(x - a_i)^2} \\ \bar{\Sigma}_{ij} &= \frac{1}{2}\epsilon_{ijk}\sigma^k \\ \bar{\Sigma}_{4i} &= -\bar{\Sigma}_{i4} = \frac{1}{2}\sigma^i, \end{aligned} \tag{A.40}$$

where i runs over $\{1, 2, 3\}$, satisfies the ASD instanton equations.

A.5.1. Infinite Dimensional Principal Bundles

In part II of these lectures we will often be discussing infinite dimensional principal bundles. Two fundamental examples:

1. As above, let $\mathcal{A}(P)$ = the set of all connections on a principal bundle P . This is an infinite-dimensional manifold. In fact, it is - itself- a principal bundle for the infinite-dimensional group $\mathcal{G}(P)$ of gauge transformations. Formally

Definition: $\mathcal{G}(P)$ is the group of automorphisms of P . These may be regarded as patchwise defined functions $g_U: U \rightarrow G$, acting on the local sections as $s_U \rightarrow s_U g_U$. If P is trivial then $\mathcal{G}(P) = \text{MAP}(\Sigma_T \rightarrow G)$.

Let us assume P is trivial. The action of $\mathcal{G}(P)$ on $\mathcal{A}(P)$ is easily seen to be that of gauge transformation:

$$A \rightarrow g^{-1}dg + g^{-1}Ag \tag{A.41}$$

This doesn't quite act freely on $\mathcal{A}(P)$, because of global gauge transformations in the center $C(G)$ of G . However, $C(G)$ is a normal subgroup so we can consider the group $\mathcal{G}(P)/C(G)$. This acts freely except at the "reducible connections." Reducible connections are connections for which the holonomy group is a proper subgroup of G . For example if A has the block decomposition

$$A = \begin{pmatrix} A_1 & 0 \\ 0 & A_2 \end{pmatrix}$$

then nontrivial global gauge transformations will fix A . Thus, at reducible connections the dimension of the fiber collapses and the quotient space is singular. However

$$\mathcal{A}^{irr} \rightarrow \mathcal{A}^{irr}/(\mathcal{G}/C(G)) \tag{A.42}$$

is a well-defined principal fiber bundle. The fiber and the base are infinite-dimensional.

2. $P = \text{MET}(\Sigma)$, the space of metrics on a surface Σ of genus p . $G = \text{Diff}(\Sigma) \times \text{Weyl}(\Sigma)$, the group of diffeomorphisms of Σ and Weyl rescalings acting as

$$h \rightarrow f^*h$$

$$h \rightarrow e^\phi h$$

The base space is $\mathcal{M}_{p,0}$, the moduli space of Riemann surfaces of genus p . We'll see below that it has dimension $6p - 6$. We will see another example, Hurwitz space, in chapter 5.

References

- [1] L. V. Ahlfors and L. Sario, *Riemann Surfaces*, Princeton University Press, 1960.
- [2] O. Alvarez, "Theory of Strings with Boundaries: Fluctuations, Topology and Quantum Gravity", Nucl. Phys. **B216** (1983) 125.
- [3] L. Alvarez-Gaume, "Supersymmetry and the Atiyah-Singer Index Theorem", Comm. Math. Phys. **90** (1983) 161;
L. Alvarez-Gaume, "Supersymmetry and Index Theory", in *NATO Advanced Study Institute on Supersymmetry*, 1984: Bonn, Germany.
- [4] L. Alvarez-Gaumé and P. Ginsparg, "The Structure of Gauge and Gravitational Anomalies", Ann. Phys. **161** (1985) 423.; Erratum: Ann. Phys. **171** (1986) 233.
- [5] I. Antoniadis, E. Gava, K. Narain, and T.R. Taylor, "Topological Amplitudes in String Theory", Nucl. Phys. **B413** (1994) 162.
- [6] E. Arbarello and M. Cornalba, "Combinatorial and Algebro-Geometric Cohomology Classes on the Moduli Space of Curves", alg-geom/9406008.
- [7] See V. Arnold, "Remarks on Enumeration of Plane Curves"; "Plane Curves, their Invariants, Perestroikas and Classifications".
- [8] P. Aspinwall and D. Morrison, "Topological Field Theory and Rational Curves", Commun. Math. Phys. **151** (1993) 245, hep-th/9110048.
- [9] M.F. Atiyah and I.M. Singer, "The index of elliptic operators I," Ann. Math. **87**(1968)484; M. F. Atiyah and G.B. Segal, "The index of elliptic operators II," Ann. Math. **87**(1968)531; M.F. Atiyah and I.M. Singer, "The index of elliptic operators III," Ann. Math. **87**(1968)546; "The index of elliptic operators IV," Ann. Math. **93**(1968)119
- [10] M. Atiyah, N. Hitchin and I. Singer, "Self-Duality in Four-Dimensional Riemannian Geometry", Proc. Royal Soc. (London) **A362** (1978) 425-461.
- [11] M. F. Atiyah and R. Bott, "The Yang-Mills Equations Over Riemann Surfaces," Phil. Trans. Roy. Soc. London **A308** (1982) 523.
- [12] M. F. Atiyah and R. Bott, "The Moment Map And Equivariant Cohomology", Topology **23** (1984) 1.
- [13] M.F. Atiyah and I.M. Singer, "Dirac operators Coupled to Vector Potentials," Proc. Natl. Acad. Sci. **81** (1984) 2597.
- [14] M. F. Atiyah, "New invariants for three and four dimensional manifolds," in the *Symposium on the Mathematical Heritage of Hermann Weyl*, R. Wells et. al. eds.
- [15] M. F. Atiyah, "Topological Field Theory", IHES Publ. Math. **68** (1989) 175.
- [16] M.F. Atiyah and L. Jeffrey, "Topological Lagrangians and Cohomology," Jour. Geom. Phys. **7** (1990) 119.
- [17] O. Babelon and C.-M. Viallet, "The Geometrical Interpretation of the Faddeev-Popov Determinant", Phys. Lett. **85B** (1979) 246.
- [18] J. Baez, Two-dimensional QCD and strings, hep-th/9309067
- [19] J. Baez and W. Taylor, "Strings and Two-dimensional QCD for Finite N", MIT-CTP-2266, hep-th/9401041.
- [20] J.L.F. Barbon and K. Demetrfi, "Effective Hamiltonians for $1/N$ Expansion in Two-Dimensional QCD", hep-th/9406046.
- [21] I. Bars, "QCD and Strings in 2d", Talk given at International Conference on Strings, Berkeley, CA, 24-29 May 1993, hep-th/9312018.
- [22] I. Bars and A. Hanson, "Quarks at the Ends of the String", Phys. Rev. **D13** (1976)1744; "A Quantum String Theory of Hadrons and its Relation to Quantum Chromodynamics in Two Dimensions", Nucl. Phys. **B111** (1976) 413.
- [23] L. Baulieu and I. Singer, "Topological Yang-Mills Symmetry", Nucl. Phys. B. Proc. Suppl. **5B** (1988) 12.
- [24] L. Baulieu and I. Singer, "The Topological Sigma Model", Commun. Math. Phys. **125** (1989) 227-237.

- [25] L. Baulieu and I. Singer, “Conformally Invariant Gauge Fixed Actions for 2-D Topological Gravity”, *Commun. Math. Phys.* **135** (1991) 253-237.
- [26] L. Baulieu and J. Thierry-Mieg, “Algebraic Structure of Quantum Gravity and Classification of Gravitational Anomalies”, *Phys. Lett.* **145B** (1989) 53.
- [27] C.M. Becchi, R. Collina, C. Imbimbo, “A Functional and Lagrangian Formulation of Two Dimensional Topological Gravity”, hep-th/9406096.
- [28] A. Beilinson and V. Ginzburg, “Infinitesimal structure of Moduli Spaces of G-Bundles,” *International Mathematics Research Notices* 1992, No. 4.
- [29] N. Berline, E. Getzler, and M. Vergne, *Heat Kernels and Dirac Operators*, Springer 1992
- [30] L. Bers, “Finite Dimensional Teichmuller Spaces and Generalizations,” *Bull. of the AMS*, **5**(1981) 131
- [31] M. Bershadsky, S. Cecotti, H. Ooguri and C. Vafa, “Kodaira Spencer Theory of Gravity and Exact Results for Quantum String Amplitudes”, HUTP-93-A025, hep-th/9309140.
- [32] I. Berstein and A.L. Edmonds, “On the Classification of Generic Branched Coverings of Surfaces”, *Illinois Journal of Mathematics*, Vol **28**, number **1**, (1984).
- [33] J. S. Birman, *Braids, Links and Mapping Class groups*, pages 11, 12, Princeton University Press, 1975.
- [34] D. Birmingham, M. Blau, M. Rakowski, and G. Thompson, “Topological Field Theories,” *Phys. Rep.* **209** (1991) 129.
- [35] J.-M. Bismut, “Localization Formulas, Superconnections, and The Index Theorem For Families,” *Comm. Math. Phys.* **103** (1986) 127.
- [36] M. Blau, “The Mathai-Quillen Formalism and Topological Field Theory”, Notes of Lectures given at the Karpacz Winter School on ‘Infinite Dimensional Geometry in Physics’, Karpacz, Poland, Feb 17-29, 1992; *J. Geom and Phys.* **11** (1991) 129.
- [37] M. Blau and G. Thompson, “Lectures on 2d Gauge Theories: Topological Aspects and Path Integral Techniques”, Presented at the Summer School in High Energy Physics and Cosmology, Trieste, Italy, 14 Jun - 30 Jul 1993, hep-th/9310144.
- [38] M. Blau and G. Thompson, “Quantum Yang-Mills Theory On Arbitrary Surfaces”, *Int. J. Mod. Phys.* **A7** (1992) 3781.
- [39] M. Blau and G. Thompson, “N=2 Topological Gauge Theory, the Euler Characteristic of Moduli Spaces, and the Casson Invariant”, *Commun. Math. Phys.* **152** (1993) 41, hep-th/9112012.
- [40] N. N. Bogoliubov D.V. Shirkov, *Introduction to the Theory of Quantized Fields*, Interscience Publishers, Inc., New York
- [41] R. Bott, “On the Chern-Weil Homomorphism and the Continuous Cohomology of Lie Groups,” *Adv. in Math.* **11** (1973) 289-303.
- [42] R. Bott and L. Tu, *Differential Forms in Algebraic Topology*, Springer Verlag, New York, 1982.
- [43] C.P. Boyer, J.C. Hurtubise, B.M. Mann and R.J. Milgram, “The Topology of the Space of Rational Maps into generalized Flag Manifolds”, to appear in *Acta. Math.*
- [44] P. Braam, “Floer Homology Groups for Homology Three-Spheres”, *Adv. in Math.* **88** (1991) 131-144.
- [45] N. Bralic, ”Exact Computation of Loop Averages in Two-Dimensional Yang-Mills Theory”, *Phys. Rev.* **D22** (1980) 3090.
- [46] C. Becchi, A. Rouet and R. Stora, “Renormalization of the Abelian Higgs-Kibble Model”, *Comm. Math. Phys.* **42** (1975) 127; “Renormalization of Gauge Theories”, I.V. Tyutin, “Gauge Invariance in Field Theory and in Statistical Physics in the Operator Formalism”, Lebedev preprint FIAN No. 39 (1975), unpublished
J. Fisch, M. Henneaux, J. Stasheff and C. Teitelboim, “Existence, Uniqueness and Cohomology of the Classical BRST Charge with Ghosts of Ghosts”, *Comm. Math. Phys.* **120** (1989) 379.

- [47] L. Brink, J. Schwarz and J. Scherk, “Supersymmetric Yang-Mills Theories”, Nucl. Phys. **B121** (1977) 77.
- [48] P. Candelas, X.C. de la Ossa, P.S. Green and L. Parkes, ”A Pair of Calabi-Yau Manifolds as an Exactly Solvable Superconformal Theory”, Nucl. Phys. **B359** (1991) 21.
- [49] Y. Choquet-Bruhat, C. DeWitt-Morette, and M. Dillard-Bleick, *Analysis, Manifolds, and Physics*, North Holland, 1977.
- [50] J.Q. Chen, *Group representation Theory for Physicists*, World Scientific, 1987, chapter 7
- [51] J.H. Conway, *Functions of One Complex Variable*, Springer.
- [52] S. Cordes, G. Moore, and S. Ramgoolam, “Large N 2D Yang-Mills Theory and Topological String Theory”, hep-th/9402107
- [53] S. Cordes, G. Moore, and S. Ramgoolam, Proceedings of the 1994 Trieste Spring School on Superstrings
- [54] S. Cordes, G. Moore, and S. Ramgoolam, Proceedings of the 1994 Les Houches school on Fluctuating Geometries.
- [55] S. Cordes, G. Moore, and S. Ramgoolam, in Les Houches Session LXII on <http://xxx.lanl.gov/lh94>.
- [56] M. Crescimanno and W. Taylor, “ Large N phases of Chiral QCD_2 , ” hep-th 9408115
- [57] M. Daniel and C.M. Viallet, “The Geometrical Setting of Gauge Theories of the Yang-Mills Type,” Rev. Mod. Phys. **52** (1980) 174
- [58] A. Dhar, P. Lakdawala, G. Mandal and S. Wadia, “String Field Theory of Two-Dimensional QCD on a Cylinder: A Realization of $W(\infty)$ Current Algebra”, Phys. Lett. **B350** (1994); hep-th/9403050.
- [59] R. Dijkgraaf, K. Intrilligator, G. Moore, and R. Plesser, unpublished.
- [60] R. Dijkgraaf and R. Rudd, unpublished.
- [61] R. Dijkgraaf, H. Verlinde and E. Verlinde, “Notes on Topological String Theory and 2-d Quantum Gravity”, lectures given at *Spring School on Strings and Quantum Gravity*, Trieste, Italy, Apr 24 - May 2, 1990.
- [62] R. Dijkgraaf and E. Witten, “Mean Field Theory, Topological Field Theory, and Multi-Matrix Models”, Nucl. Phys. **B342** (1990) 486.
- [63] J. Distler, “2 – D Quantum Gravity, Topological Field Theory, and the Multicritical Matrix Models,” Nucl. Phys. **B342** (1990) 523.
- [64] M. Dine, N. Seiberg, X. Wen and E. Witten, “Nonperturbative Effects on the SString World Sheet”, Nucl. Phys. **B278** (1986) 769, Nucl. Phys. **B289** (1987) 319.
- [65] S. Donaldson, “An Application of Gauge Theory to Four Dimensional Topology”, J. Diff. Geom. **18** (1983) 279.
- [66] S. Donaldson, “Polynomial Invariants for Smooth Four Manifolds”, Topology **29** (1990) 237.
- [67] S.K. Donaldson and P.B. Kronheimer, *The Geometry of Four-Manifolds*, Clarendon Press, Oxford, 1990.
- [68] M.R. Douglas, “Conformal Field Theory Techniques for Large N Group Theory,” hep-th/9303159; M.R. Douglas, “Conformal Field Theory Techniques in Large N Yang-Mills Theory”, hep-th/9311130, to be published in the proceedings of the May 1993 Cargèse workshop on Strings, Conformal Models and Topological Field Theories.
- [69] M. R. Douglas, “Some Comments on QCD String,” RU-94-09, hep-th/9401073, to appear in Proceedings of the Strings ’93 Berkeley conference.
- [70] M.R. Douglas, “Conformal Field Theory Techniques in Large N Yang-Mills Theory,” hep-th 9303159.
- [71] M.R. Douglas, “Large N Gauge Theory- Expansions and Transitions,” hep-th/9409098. ■
- [72] M. Douglas and V.A. Kazakov, “Large N Phase Transition in Continuum QCD_2 ”, Phys. Lett. **B319** (1993) 219, hep-th/9305047

- [73] J.M. Drouffe and J. B. Zuber, “Strong Coupling and Mean Field Methods in Lattice Gauge theories”, Phys. Rept **102** (1983) 1.
- [74] J. J. Duistermaat and G. J. Heckman, “On The Variation In The Cohomology In The Symplectic Form Of The Reduced Phase Space,” Invent. Math. **69** (1982) 259.
- [75] A. L. Edmonds, “Deformation of Maps to Branched Coverings in Dimension Two”, Annals of Mathematics **110** (1979), 113-125.
- [76] T. Eguchi, P.B. Gilkey, and A.J. Hanson, “Gravitation, Gauge Theories, and Differential Geometry”, Phys. Rep. **66**(1980) 214.
- [77] T. Eguchi, H. Kanno, Y. Yamada and S.-K. Yang, ”Topological Strings, Flat Coordinates and Gravitational Descendants” hep-th/9302048.
- [78] C. L. Ezell, “Branch Point Structure of Covering Maps onto Nonorientable Surfaces”, Transactions of the American Mathematical society, vol **243**, 1978.
- [79] D. Fine, “Quantum Yang-Mills On The Two-Sphere”, Commun. Math. Phys. **134** (1990) 273; “Quantum Yang-Mills On A Riemann Surface,” Commun. Math. Phys. **140** (1991) 321.
- [80] A. Floer, “The Unregularized Gradient Flow of the Symplectic Action”, Comm. Pure Appl. Math. **41** (1988) 775-813.
- [81] A. Floer, “Symplectic Fixed-Points and Holomorphic Spheres”, Commun. Math. Phys. **120** (1989) 575-611.
- [82] A. Floer, “Witten’s Complex and Infinite Dimensional Morse Theory”, J. Diff. Geom. **30** (1989) 207-221.
- [83] A. Floer, “An Instanton-Invariant for 3-Manifolds”, Commun. Math. Phys. **118** (1988) 215-239.
- [84] R. Forman, “Small Volume Limits of $2 - d$ Yang-Mills,” preprint, Rice University (1991).
- [85] D. Freed and K. Uhlenbeck, *Instantons and 4-Manifolds*, Springer 1984.
- [86] D. Friedan and P. Windey, “Supersymmetric Derivation of the Atiyah-Singer Index and the Chiral Anomaly”, Nucl. Phys. **B235** (1984) 395.
- [87] W. Fulton, “Hurwitz Schemes and Irreducibility of Moduli of Algebraic Curves”, Annals of Math. **90** (1969) 542.
- [88] O. Ganor, J. Sonnenschein and S. Yankielowicz, ”The String Theory Approach to Generalized 2D Yang-Mills Theory”, hep-th/9407114
- [89] E. Getzler, “Two-Dimensional Topological Gravity and Equivariant Cohomology,” hep-th/9305013.
- [90] See, e.g., J. Glimm and A. Jaffe, *Quantum Physics*, Springer 1981.
- [91] D. Gross, “Some New/Old Approaches to QCD,” Int. Workshop on String Theory, Quantum Gravity and the Unification of Fundamental Interactions, Rome, Italy, 21-26 Sept. 1992, hep-th/9212148.
- [92] P. Griffiths and J. Harris, *Principles of Algebraic geometry*, p. 445, J.Wiley and Sons, 1978.
- [93] M. Gromov, “Pseudo-Holomorphic Curves in Symplectic Manifolds”, Invent. Math. **82** (1985) 307-347.
- [94] D. Gross, “Two Dimensional QCD as a String Theory”, Nucl. Phys. **B400** (1993) 161, hep-th/9212149.; D. Gross and W. Taylor, “Two-dimensional QCD is a String Theory”, Nucl. Phys. **B400** (1993) 181, hep-th/93011068; D. Gross and W. Taylor, “Twists and Loops in the String Theory of Two Dimensional QCD”, Nucl. Phys. **403** (1993) 395, hep-th/9303046.
- [95] D. Gross and A. Matytsin, “Instanton Induced Large N Phase Transitions in Two and Four Dimensional QCD,” hep-th/9404004
- [96] D. Gross and A. Matytsin, “Some properties of Large N Two Dimensional Yang Mills Theory,” hep-th 9410054.
- [97] D.J. Gross and W. Taylor, “Two-Dimensional QCD and Strings”, Talk presented at Int. Conf. on Strings ’93, Berkeley CA, 24-29 May 1993; hep-th/9311072.

- [98] D. Gross and E. Witten, “A Possible Third Order Phase Transition on the Large N Lattice Gauge Theory”, *Phys. Rev.* **D21** (1980) 446.
- [99] L. Gross, C. King and A. Sengupta, “Two-Dimensional Yang-Mills via Stochastic Differential Equations”, *Ann. of Phys.* **194** (1989) 65.
- [100] M. Hamermesh, *Group Theory and its applications to physical problems*, Addison-Wesley 1962
- [101] M.A. Guest, “Topology of the Space of Absolute Minima of the Energy Functional”, *Amer. J. Math.* **106** (1984) 21-42.
- [102] J. Harvey and A. Strominger, “String Theory and the Donaldson Polynomial”, *Commun. Math. Phys.* **151** (1993) 221, hep-th/9108020.
- [103] J. Harris and I. Morrison, “Slopes of Effective Divisors on the Moduli Space of Stable Curves”, *Invent. Math.* **99** (1990) 321-355.
- [104] J. Harris and D. Mumford, “On the Kodaira Dimension of the Moduli Space of Curves”, *Invent. Math.* **67** (1982) 23-86.
- [105] F. Hirzebruch, *Topological Methods in Algebraic Geometry*, Springer Verlag, 1966.
- [106] N. Hitchin, “The Geometry and Topology of Moduli Spaces”, in *Global Geometry and Mathematical Physics*, LNM 1451, L. Alvarez-Gaumé et. al., eds.
- [107] P. Horava, “Topological Strings and QCD in Two Dimensions”, to appear in Proc. of The Cargese Workshop, 1993; hep-th/9311156.
- [108] P. Horava, “Two-Dimensional String Theory and the Topological Torus”, *Nucl. Phys.* **B386** (1992) 383-404.
- [109] E. Horikawa, “On Deformations of Holomorphic Maps, I, II, III”, *J. Math. Soc. Japan*, **25** (1973) 647; *ibid* **26** (1974) 372; *Math. Ann.* **222** (1976) 275.
- [110] J.C. Hurtubise, “Holomorphic Maps of a Riemann Surface into a Flag Manifold”, McGill preprint, 1994.
- [111] D. Husemoller, *Fiber Bundles*, 3rd edition, Springer, 1993.
- [112] R.E. Ingram , “Some Characters of the Symmetric Group”, *Proc. Amer. Math. Soc.* (1950), 358-369
- [113] C.J. Isham, *Modern Differential Geometry for Physicists*, World Scientific, 1989
- [114] J. Kalkman, “BRST Model for Equivariant Cohomology and Representatives for the Equivariant Thom Class”, *Commun. Math. Phys.* **153** (1993) 447; “BRST Model Applied to Symplectic Geometry”, PRINT-93-0637 (Utrecht), hep-th/9308132.
- [115] H. Kanno, “Weil Algebra Structure and Geometrical Meaning of BRST Transformation in Topological Quantum Field Theory,” *Z. Phys.* **C43** (1989) 477.
- [116] T. Karki and A.J. Niemi, “On the Duistermaat-Heckman Integration Formula and Integrable Models”, hep-th/9402041.
- [117] V.A. Kazakov and I. Kostov, “Non-linear Strings in Two-Dimensional $U(\infty)$ Gauge Theory,” *Nucl. Phys.* **B176** (1980) 199-215; “Computation of the Wilson Loop Functional in Two-Dimensional $U(\infty)$ Lattice Gauge Theory”, *Phys. Lett.* **B105** (1981) 453; V.A. Kazakov, “Wilson Loop Average for an Arbitrary Contour in Two-Dimensional $U(N)$ Gauge Theory”, *Nuc. Phys.* **B179** (1981) 283-292.
- [118] V.A. Kazakov, “ $U(\infty)$ Lattice Gauge Theory as a Free Lattice String Theory”, *Phys. Lett.* **B128** (1983) 316; V.I. Kostov, “Multicolour QCD in Terms of Random Surfaces”, *Phys. Lett.* **B138** (1984) 191.
- [119] “Large N Phase Transition In The Heat Kernel On The $U(N)$ Group,” V.A. Kazakov and Thomas Wynter, hep-th 9408029.
- [120] V. Kazakov, Strings, loops, knots and gauge fields, hep-th/9308135
- [121] F. Kirwan, *Cohomology of Quotients In Symplectic And Algebraic Geometry*, Princeton University Press.
- [122] F.C. Kirwan, “On Spaces of Maps from Riemann Surfaces to Grassmannians and Applications to the Cohomology of Vector Bundles”, *Ark. Math.* **24** (1986) 221-275.
- [123] L. Jeffrey and F. Kirwan, “Localization for Nonabelian Group Actions”, alg-geom/9307001.

- [124] F. Knudsen, "The Projectivity of the Moduli Space of Stable Curves", *Math. Scand.* **52** (1983) 161.
- [125] S. Kobayashi and K. Nomizu, *Foundations of Differential Geometry I,II*, Interscience Publishers, New York, 1963.
- [126] M. Kontsevich, "Intersection Theory On The Moduli Space Of Curves And The Matrix Airy Function", *Commun. Math. Phys.* **147** (1992) 1.
- [127] M. Kontsevich and Yu. Manin, "Gromov-Witten Classes, Quantum Cohomology, and Enumerative Geometry," hep-th/9402147; MPI preprint.
- [128] M. Kontsevich, "Enumeration of rational curves via torus actions," hep-th/9405035, MPI preprint
- [129] I.K. Kostov, "Continuum QCD2 in Terms of Discretized Random Surfaces with Local Weights", Saclay-SPht-93-050; hep-th/9306110.
- [130] P.B. Kronheimer and T.S. Mrowka, "The genus of embedded surfaces in the projective plane," preprint.
- [131] D. Kutasov, "Geometry on the Space of Conformal Field Theories and Contact Terms," *Phys. Lett.* **220B** (1989)153.
- [132] J.M.F. Labastida, M. Pernici, and E. Witten "Topological Gravity in Two Dimensions," *Nucl. Phys.* **B310** (1988) 611.
- [133] W. Lerche, C. Vafa , and N.P. Warner , "Chiral Rings in $N = 2$ Superconformal Theories", *Nucl.Phys.* **B324** (1989) 427.
- [134] B. Lian and G. Zuckerman, "New Perspectives on the BRST Algebraic Structure of String Theory", *Commun. Math. Phys.* **154** (1993) 613; hep-th/9111072.
- [135] A. Losev, "Descendants constructed from matter fields in topological Landau-Ginzburg theories coupled to topological gravity," *Theor. Math. Phys.*,95,N2,(1993),p.317-327, hep-th/9211090; Structures of K.Saito theory of primitive form in topological theories coupled to topological gravity, in *Integrable models and strings*, Lecture notes in Physics, 436, Springer Verlag,1994, Proc. of the III Baltic RIM Conf.,Helsinki, September 1993,13-17, p.172-193; A.Losev and I.Polyubin, "On Connection between Topological Landau-Ginzburg Gravity and Integrable Systems," ITEP Preprint PRINT-930412(May 1993), submitted to IJMP, hep-th/9305079.
- [136] Yu. I. Manin, *Quantized Fields and Complex Geometry*, Springer
- [137] W.S. Massey, *A Basic Course in Algebraic Topology*, Springer-Verlag, 1991.
- [138] V. Mathai and D. Quillen, "Superconnections, Thom Classes, and Equivariant Differential Forms", *Topology* **25** (1986) 85.
- [139] D. McDuff and D. Salamon, "*J*-Holomorphic Curves and Quantum Cohomology", preprint, 1994.
- [140] A. Migdal, "Recursion Relations in Gauge Theories", *Zh. Eksp. Teor. Fiz.* **69** (1975) 810 (*Sov. Phys. JETP*. **42** 413).
- [141] A. A. Migdal, "Loop Equations and $1/N$ Expansion", *Phys. Rep.* **102** (1983)199-290; G. 't Hooft, "A Planar Diagram Theory for Strong Interactions, *Nucl. Phys.* **B72** (1974) 461.
- [142] M. Mijayima, "On the Existence of Kuranishi Family for Deformations of Holomorphic Maps", *Science Rep. Kagoshima Univ.*, **27** (1978) 43.
- [143] E. Miller, "The Homology of the Mapping Class Group", *J. Diff. Geom.* **24** (1986)1
- [144] J.W. Milnor and J. D. Stasheff, *Characteristic Classes*, Princeton, 1974.
- [145] J. Minahan, "Summing over Inequivalent Maps in the String Theory of QCD", *Phys. Rev.* **D47** (1993) 3430.
- [146] J. Minahan and A. Polychronakos, "Classical Solutions for two dimensional QCD on the sphere", *Nucl. Phys.* **B422** (1994) 172; hep-th/9309119
- [147] J. Minahan and A. Polychronakos, "Equivalence of Two Dimensional QCD and the $c = 1$ Matrix Model", *Phys. Lett.* **B312** (1993) 155; hep-th/9303153.
- [148] J. Minahan and A. Polychronakos, "Interacting Fermion Systems from Two Dimensional QCD", *Phys. Lett.* **326** (1994) 288; hep-th/9309044.

- [149] D. Morrison, “Compactifications of Moduli Spaces Inspired by Mirror Symmetry”, alg-geom/9304007.
- [150] D. Montano and J. Sonnenschein, “Topological Strings”, Nuc. Phys. **B313** (1989) 258
- [151] G. Moore, “Finite in All Directions”, hep-th/9305139.
- [152] G. Moore, “2D Yang-Mills Theory and Topological Field Theory,” hep-th/9409044, to appear in the proceedings of ICM94
- [153] G. Moore and N. Seiberg, “Polynomial Equations for Rational Conformal Field Theories,” Phys. Lett. **212B**(1988)451; “Classical and Quantum Conformal Field Theory”, Commun. Math. Phys. **123**(1989)177; “Lectures on Rational Conformal Field Theory”, in *Strings 90*, the proceedings of the 1990 Trieste Spring School on Superstrings.
- [154] G. Moore, N. Seiberg, and M. Staudacher, “From Loops to States in 2D Quantum Gravity”, Nucl. Phys. **B362** (1991) 665
- [155] S. Morita, “Characteristic Classes of Surface Bundles”, Inv. Math. **90** (1987) 551.
- [156] D. Morrison and R. Plesser, “Quantum Cohomology and Mirror Symmetry for a Hypersurface in a Toric Variety,” to appear.
- [157] D. Mumford, “Towards an Enumerative Geometry of the Moduli Space of Curves”, in *Arithmetic and geometry*, M. Artin and J. Tate eds., Birkhauser, 1983.
- [158] R.C. Myers and V. Periwal, “Topological Gravity and Moduli Space”, Nucl. Phys. **B333** (1990) 536.
- [159] S.G. Naculich, H.A. Riggs, H.J. Schnitzer, ‘The String Calculation of Wilson Loops in Two-Dimensional Yang-Mills Theory,’ hep-th/9406100.
- [160] S.G. Naculich, H. A. Riggs and H.G. Schnitzer, “2D Yang Mills Theories are String Theories,” Mod. Phys. Lett. **A8** (1993) 2223; hep-th/9305097.
- [161] M. Namba, “Families of Meromorphic Functions on Compact Riemann Surfaces”, Lecture Notes in Mathematics, Number 767, Springer Verlag, New York, 1979.
- [162] A. Nersessian, “Equivariant Localization: BV-geometry and Supersymmetric Dynamics”, hep-th/9310013
- [163] A.J. Niemi and O. Tirkkonen, “Equivariance, BRST, and Superspace,” hep-th/9403126
- [164] K.H. O’Brien and J.-B. Zuber, “Strong Coupling Expansion of Large N QCD and Surfaces”, Nucl. Phys. **B253** (1985) 621.
- [165] S. Okubo, J. Math. Phys. **18** (1977) 2382
- [166] S. Ouvry, R. Stora and P. Van Baal, “On the Algebraic Characterization of Witten’s Topological Yang-Mills Theory”, Phys. Lett. **220B** (1989)159
- [167] H. Ooguri and C. Vafa, “Self-Duality and $N = 2$ String Magic,” Mod.Phys.Lett. **A5** (1990) 1389-1398; “Geometry of $N = 2$ Strings,” Nucl.Phys. **B361** (1991) 469-518.
- [168] S. Panzeri, “The $c=1$ matrix models of two-dimensional Yang Mills Theories,” DFTT 36/93, 9307173
- [169] J.-S. Park, “Holomorphic Yang-Mills theory on compact Kahler manifolds,” hep-th/9305095; Nucl. Phys. **B423** (1994) 559; J.-S. Park, “ $N = 2$ Topological Yang-Mills Theory on Compact Kähler Surfaces”, Commun. Math, Phys. **163** (1994) 113; J.-S. Park, “ $N = 2$ Topological Yang-Mills Theories and Donaldson Polynomials”, hep-th/9404009.
- [170] A. Partensky, J. Math. Phys., **13**, 1972, 1503
- [171] R. C. Penner, “Perturbative Series and the Moduli Space of Riemann Surfaces, J. Diff. Geo. **27** (1988) 35-53.
- [172] A. M. Perelomov and V. S. Popov, Sov. J. of Nuc. Phys. **3** (1966) 676
- [173] J. Polchinski, “Strings and QCD?” Talk presented at the Symposium on Black Holes, Wormholes, Membranes and Superstrings,” Houston, 1992; hep-th/9210045
- [174] A.M. Polyakov, “Gauge Fields as Rings of Glue,” Nucl. Phys. **B164** (1980) 171.
- [175] A.M. Polyakov, “Quantum Geometry of Bosonic Strings,” Phys. Lett. **103B**(1981)207
- [176] A.M Polyakov, “Fine Structure of Strings”, Nucl. Phys. **B268** (1986) 406.

- [177] A.M. Polyakov, "A Few Projects in String Theory", PUPT-1394; hep-th/9304146.
- [178] A. Pressley and G. Segal, *Loop Groups*, Oxford Math. Monographs, Clarendon, NY, 1986.
- [179] S. Piunikhin, "Quantum and Floer Cohomology have the Same Ring Structure", hep-th/9401130.
- [180] The following construction goes back to D. Quillen, "Rational Homotopy Theory," Ann. of Math. **90** (1969) 205. The application to the present case was developed with G. Zuckerman.
- [181] S. Rajeev, "Quantum Hadrodynamics in Two-Dimensions", preprint hep-th/9401115.
- [182] S. Ramgoolam, "Comment on Two-Dimensional $O(N)$ and $Sp(N)$ Yang Mills Theories as String Theories", Nuc. Phys. **B418**, (1994) 30; hep-th/9307085.
- [183] S. Ramgoolam, Higher Casimir Perturbations of Two Dimensional Yang Mills Theories, unpublished.
- [184] S. Ramgoolam, to appear.
- [185] Y. Ruan and G. Tian, "Mathematical Theory of Quantum Cohomology", preprint 1994.
- [186] R. Rudd, "The String Partition Function for QCD on the Torus", hep-th/9407176.
- [187] B. Rusakov, "Loop Averages And Partition Functions in $U(N)$ Gauge Theory On Two-Dimensional Manifolds", Mod. Phys. Lett. **A5** (1990) 693.
- [188] V. Sadov, "On Equivalence of Floer's and Quantum Cohomology", hep-th/9310153.
- [189] D. Salamon, "Morse Theory, the Conley Index and the Floer Homology", Bull. AMS **22** (1990) 13-140.
- [190] A. Schwarz, "The Partition Function Of Degenerate Quadratic Functional And Ray-Singer Invariants", Lett. Math. Phys. **2** (1978) 247.
- [191] S. Shenker, "The Strength of Non-Perturbative Effects in String Theory", in Carg'ese Workshop on *Random Surfaces, Quantum Gravity and Strings*, Garg'ese, France, May 28 - Jun 1 1990, eds. O. Alvarez, E. Marinari, and P. Windey (Plenum, 1991)
- [192] G. Segal, "The Topology of Rational Functions", Acta. Math. **143** (1979) 39-72.
- [193] G. B. Segal, "The Definition of Conformal Field Theory", preprint, 1989.
- [194] G.B. Segal, Lecture at Yale, March, 1992.
- [195] A. Sengupta, "The Yang-Mills Measure For S^2 ," to appear in J. Funct. Anal., "Quantum Gauge Theory On Compact Surfaces," preprint.
- [196] I. Singer, "Some Remarks on the Gribov Ambiguity", Commun. Math Phys. **60** (1978) 7.
- [197] M.F. Sohnius, "Introducing Supersymmetry," Phys. Rep. **128**(1985)39
- [198] E. H. Spanier, *Algebraic Topology*, Mc. Graw-Hill, Inc. 1966.
- [199] N. Steenrod, *The topology of Fiber Bundles*, Princeton Univ. Press
- [200] R. Stora, "Equivariant Cohomology and Cohomological Field Theories," lecture notes
- [201] R. Stora, F. Thuillier, J.C. Wallet, First Carribean Spring School of Math. and Theor. Phys. May 30 (1993)
- [202] A. Strominger, "Loop Space Solution of Two-Dimensional QCD", Phys. Lett. **101B** (1981) 271.
- [203] C.H. Taubes, "Seiberg-Witten invariants and symplectic forms," preprint
- [204] W. Taylor, "Counting strings and Phase transitions in 2d QCD", MIT-CTP-2297; hep-th/9404175
- [205] P. van Baal, "An Introduction to Topological Yang-Mills Theory," Acta Physica Polonica, **B21**(1990) 73
- [206] C. Vafa, "Topological Mirrors", in *Essays on Mirror Manifolds*, S-T Yau, ed. International Press 1992. hep-th/9111017.
- [207] C. Vafa and E. Witten, "A Strong Coupling Test of S -Duality", hep-th/9408074.
- [208] G. Veneziano, "Construction of a Crossing-Symmetric, Regge-Behaved Amplitude for Linearly Rising Trajectories," Nuovo Cim. **57A** 190, (1968).

- [209] E. Verlinde and H. Verlinde , “A Solution of Two-Dimensional Topological Quantum Gravity”, Nucl. Phys. **B348** (1991) 457, R. Dijkgraaf, E. Verlinde and H. Verlinde, “Loop Equations and Virasoro Constraints in Nonperturbative 2d Quantum Gravity”, Nucl. Phys. **B348** (1991) 435; “Topological Strings in $d < 1$ ”, Nucl. Phys. **B352** (1991) 59; “Notes on Topological String Theory and 2-d Quantum Gravity”, in *String Theory and Quantum Gravity*, Proc. Trieste Spring School, April 24 - May 2, 1990 (World Scientific, Singapore, 1991).
- [210] E. Verlinde, “Fusion Rules and Modular Transformations in 2d Conformal Field Theory”, Nucl. Phys. **B300** (1988) 360.
- [211] J. Vick, *Homology Theory*, Academic Press, 1973.
- [212] R.O. Wells, *Differential Analysis on Complex Manifolds*, Springer 1980
- [213] J. Wess and J. Bagger, *Supersymmetry and Supergravity*, Princeton University Press, Princeton, 1983.
- [214] K.G. Wilson, “Confinement of Quarks”, Phys. Rev. **D10** (1974) 2445.
- [215] E. Witten, “Dynamical Breaking of Supersymmetry”, Nucl. Phys. **B188** (1981) 513.
- [216] E. Witten, “Constraints on Supersymmetry Breaking”, Nucl. Phys. **B202** (1982) 253.
- [217] E. Witten, “Supersymmetry and Morse Theory”, J. Diff. Geom. **17** (1982) 661.
- [218] E. Witten, “Topological Quantum Field Theory”, Commun. Math. Phys. **117** (1988) 353.
- [219] E. Witten, “Topological sigma models ”, Commun. Math. Phys. **118**, 411-419 (1988).
- [220] E. Witten, “The Search for Higher Symmetry in String Theory”, Phil. Trans. Royal Soc. London **B320** (1989) 349-357.
- [221] E. Witten, “Topological Gravity,” Phys. Lett. **206B** (1988) 601.
- [222] E. Witten, “Quantum Field Theory and the Jones Polynomial”, Commun. Math. Phys. **121** (1989) 351.
- [223] E. Witten, “Two-dimensional Gravity and Intersection Theory on Moduli Space”, in *Cambridge 1990, Proceedings, Surveys in Differential geometry*, 243-310.
- [224] E. Witten, “Algebraic Geometry Associated with Matrix Models of Two-Dimensional Gravity”, IASSNS-HEP-91/74.
- [225] E. Witten, “The N-Matrix Model and gauged WZW models”, Nucl. Phys. **B371** (1992) 191.
- [226] E. Witten, “On Quantum gauge theories in two dimensions,” Commun. Math. Phys. **141** (1991) 153.
- [227] E. Witten, “Two Dimensional Gauge Theories Revisited”, J. Geom. Phys. **G9** (1992) 303; hep-th/9204083.
- [228] E. Witten, “On the Structure of the Topological Phase of Two Dimensional Gravity”, Nucl. Phys. **B340** (1990) 281
- [229] E. Witten, “Introduction to Cohomological Field Theories”, Lectures at Workshop on Topological Methods in Physics, Trieste, Italy, Jun 11-25, 1990, Int. J. Mod. Phys. **A6** (1991) 2775.
- [230] E. Witten, “Mirror Manifolds and Topological Field Theory”, hep-th/9112056, in *Essays on Mirror Manifolds* International Press 1992.
- [231] E. Witten, “3D Chern-Simons as Topological Open String”; hep-th/9207094.
- [232] E. Witten, “Phases of N=2 Theories in Two Dimensions”, Nucl. Phys. **B403** (1993) 159; hep-th/9301042.
- [233] E. Witten, “Supersymmetric Gauge Theory on a Four-Manifold”, hep-th/9403193.
- [234] E. Witten, “Monopoles and four-manifolds,” hep-th/9411102
- [235] D. P. Zhelobenko, *Translations of American Math. Monographs*, **40**