

Diss. ETH No. 17125

# Oblivious-Transfer Amplification

A dissertation submitted to the  
SWISS FEDERAL INSTITUTE OF TECHNOLOGY  
ZÜRICH

for the degree of  
Doctor of Sciences

presented by

JÜRIG WULLSCHLEGER  
Dipl. Inf.-Ing. ETH

born July 5, 1975  
citizen of Vordemwald, AG, Switzerland

accepted on the recommendation of

Prof. Dr. Stefan Wolf, examiner  
Prof. Dr. Ivan Damgård, co-examiner

2024



# Acknowledgments

First of all, I would like to thank Stefan Wolf who has been a great advisor. Many results in this thesis are the outcome of endless discussions with him. I also want to thank Ivan Damgård for co-refereeing this thesis.

I would also like to thank all the people I was able to work with or talk to about my research during the last few years, including Don Beaver, Hugue Blier, Gilles Brassard, Anne Broadbent, Daniel Burgarth, Claude Crépeau, Meriem Debbih, Simon-Pierre Desrosiers, Thomas Dübendorfer, Frédéric Dupuis, Serge Fehr, Matthias Fitzi, Viktor Galliard, Sébastien Gambs, Nicolas Gisin, Iftach Haitner, Esther Hänggi, Patrick Hayden, Martin Hirt, Thomas Holenstein, Reto Kohlas, Robert König, Ueli Maurer, Remo Meier, André Méthot, Kirill Morozov, Yvonne Anne Oswald, Jörn Müller-Quade, Anderson Nascimento, Krzysztof Pietrzak, Bartosz Przydatek, Melanie Raemy, Dominik Raub, Renato Renner, Louis Salvail, George Savvides, Valerio Scarani, Christian Schaffner, Jean-Raymond Simard, Johan Sjödin, Christian Sommer, Reto Strobl, Alain Tapp, Stefano Tessaro, Dominique Unruh, Stephanie Wehner, Douglas Wikström, Andreas Winter, Jon Yard, and Vassilis Zikas.

Special thanks to Thomas Holenstein for answering many questions and for giving me many helpful hints and ideas, to Jörn Müller-Quade, Dominik Raub, Renato Renner and Dominique Unruh for answering my questions about universal composability, to Iftach Haitner for helpful comments on the computational part of this thesis, and to Esther Hänggi, Melanie Raemy and Christian Schaffner for proof-reading this thesis and pointing out many errors.

This research was supported by the Swiss National Science Foundation

(SNF), by the Natural Sciences and Engineering Research Council of Canada (NSERC) and by the Fonds Québécois de la Recherche sur la Nature et les Technologies (FQRNT).

# Abstract

In *two-party computation*, two players want to collaborate in a secure way in order to achieve a common goal, but, they do not trust each other and do not want the other to learn more than necessary about their inputs. Unfortunately, two-party computation is impossible to achieve *unconditionally* securely, i.e., such that even an adversary with infinite computing power has no chance in breaking the system. We do have implementations in the *computational* setting, i.e., where we assume that the computing power of the adversary is bounded, but the security of these implementations are based on unproven assumptions such as the assumption that factoring is hard.

However, if a very simple primitive called *oblivious transfer* is available, then *any* two party computation can be implemented in an unconditionally secure way. In this thesis we investigate what weaker forms of oblivious transfer still allow for implementing oblivious transfer, and hence any two-party computation.

First of all, we will show that oblivious transfer is equivalent to a randomized form of oblivious transfer, and that this randomized oblivious transfer is in fact *symmetric*. It follows that also oblivious transfer is symmetric.

Then, we present a protocol that implements oblivious transfer from a weakened oblivious transfer called *universal oblivious transfer*, where one of the two players may get additional information. Our reduction is about twice as efficient as previous results.

*Weak oblivious transfer* is an even weaker form of oblivious transfer, where both players may obtain additional information about the other player's

input, and where the output can contain errors. We give a new, weaker definition of weak oblivious transfer, as well as new reductions with a more detailed analysis.

Finally, we show that any protocol that implements oblivious transfer from weak oblivious transfer can be used in the computational setting to implement computationally secure oblivious transfer from *computational weak oblivious transfer*, which is a computational version of weak oblivious transfer, where the additional information both players may obtain about the other player's input is only *computationally* bounded.

# Zusammenfassung

*Sichere Zweiparteienberechnung* erlaubt es zwei Spielern, die einander nicht vertrauen, gemeinsam eine Berechnung durchzuführen, ohne dass der jeweils andere Spieler irgendwelche zusätzlichen Informationen über ihre Eingabe erfährt. Leider ist es unmöglich eine solche Berechnung so auszuführen, dass sie selbst gegen einen berechnemässig unbeschränkten Angreifer sicher ist. Unter der Annahme, dass der Angreifer berechnemässig beschränkt ist, existieren sichere Protokolle, jedoch basiert die Sicherheit dieser Protokolle auf zusätzlichen Annahmen, wie zum Beispiel der Annahme, dass Faktorisieren schwierig ist.

Wenn jedoch eine Primitive mit dem Namen *vergessliche Übertragung* gegeben ist, dann kann *jede* Zweiparteienberechnung sicher gegen unbeschränkte Angreifer ausgeführt werden. In dieser Arbeit untersuchen wir, welche schwächeren Formen von vergesslicher Übertragung uns immer noch erlauben, eine sichere vergessliche Übertragung auszuführen.

Zuerst zeigen wir, dass vergessliche Übertragung äquivalent ist zu einer randomisierten vergesslichen Übertragung, und dass diese Primitive *symmetrisch* ist. Daraus folgt, dass vergessliche Übertragung ebenfalls symmetrisch ist.

*Universelle vergessliche Übertragung* ist eine schwächere Variante von vergesslicher Übertragung, in welcher einer der beiden Spieler zusätzliche Informationen erhalten kann. Wir zeigen ein neues, effizienteres Protokoll um daraus vergessliche Übertragung herzustellen.

*Schwache vergessliche Übertragung* ist eine noch schwächere Form von vergesslicher Übertragung, in welcher beide Spieler zusätzliche Informa-

tion erhalten können und die Übertragung falsch sein kann. Wir geben sowohl eine neue, schwächere Definition von schwacher vergesslicher Übertragung, als auch neue Protokolle wie man daraus vergessliche Übertragung herstellen kann.

Schliesslich zeigen wir, dass jedes Verfahren, welches vergessliche Übertragung aus schwacher vergesslicher Übertragung herstellt, auch eingesetzt werden kann, um berechenmässig sichere vergessliche Übertragung aus *berechenmässig schwacher vergesslicher Übertragung* herzustellen.



# Contents

<b>1</b>	<b>Introduction</b>	<b>1</b>
1.1	Background . . . . .	3
1.2	Outline of the Thesis . . . . .	8
<b>2</b>	<b>Preliminaries</b>	<b>11</b>
2.1	Notation . . . . .	11
2.2	Distances between Distributions . . . . .	11
2.3	Prediction of Random Variables . . . . .	15
<b>3</b>	<b>Secure Two-Party Computation</b>	<b>21</b>
3.1	Two-Party Computation . . . . .	21
3.2	Distinguishing Systems . . . . .	23
3.3	Adversaries and Secure Protocols . . . . .	24
3.3.1	The Malicious Model . . . . .	25
3.3.2	The Semi-Honest Model . . . . .	28
3.3.3	The Weak Semi-Honest Model . . . . .	31
3.4	Discussion . . . . .	33

<b>4</b>	<b>Oblivious Transfer</b>	<b>35</b>
4.1	(Randomized) Oblivious Transfer . . . . .	36
4.2	Oblivious Transfer is Symmetric . . . . .	41
4.3	In the Semi-Honest Model . . . . .	43
4.4	Information-Theoretic Security Conditions . . . . .	45
4.4.1	In the Malicious Model . . . . .	45
4.4.2	In the Semi-Honest Model . . . . .	47
<b>5</b>	<b>Universal Oblivious Transfer</b>	<b>49</b>
5.1	Min-Entropy and Randomness Extraction . . . . .	50
5.2	Definition of Universal Oblivious Transfer . . . . .	53
5.3	Universal Oblivious Transfer Amplification . . . . .	54
5.4	Applications . . . . .	57
<b>6</b>	<b>Weak Oblivious Transfer</b>	<b>59</b>
6.1	Definition of WOT . . . . .	61
6.1.1	In the Semi-Honest Model . . . . .	62
6.1.2	In the Malicious Model . . . . .	64
6.1.3	Relation to Previous Definitions . . . . .	67
6.2	Impossibility Results . . . . .	67
6.3	Basic Protocols for WOT Amplification . . . . .	69
6.3.1	In the Semi-Honest Model . . . . .	69
6.3.2	In the Malicious Model . . . . .	74
6.4	WOT Amplification if $\varepsilon = 0$ . . . . .	76
6.5	WOT Amplification if $p = 0$ or $q = 0$ . . . . .	79

6.6	WOT Amplification if $p, q, \varepsilon > 0$ .	83
6.7	Discussion and Open Problems	88
<b>7</b>	<b>Computational Weak Oblivious Transfer</b>	<b>89</b>
7.1	Preliminaries	89
7.2	Pseudo-Randomness Extraction	91
7.3	Definition of Computational WOT	94
7.4	Computational-WOT Amplification	97
7.5	Discussion and Open Problems	100
<b>A</b>	<b>Appendix</b>	<b>111</b>
A.1	Formal Technicalities	111



## Chapter 1

# Introduction

On January 16, 1797, Johann Wolfgang von Goethe (1749-1832) sent a letter to the publisher Vieweg with the following content (translated to English by [MT98]):

*“I am inclined to offer Mr. Vieweg from Berlin an epic poem, Hermann and Dorothea, which will have approximately 2000 hexameters. [...] Concerning the royalty we will proceed as follows: I will hand over to Mr. Counsel Böttiger a sealed note which contains my demand, and I wait for what Mr. Vieweg will suggest to offer for my work. If his offer is lower than my demand, then I take my note back, unopened, and the negotiation is broken. If, however, his offer is higher, then I will not ask for more than what is written in the note to be opened by Mr. Böttiger.”*

The reason for Goethe to choose such a complicated scheme was not to maximize his profit — he would not have earned less by just selling it to Vieweg — he wanted to gain information on how much Vieweg was willing to pay for his work. Indeed, his procedure can be viewed as a second price auction, where Goethe himself was playing the second bidder [MT98]. However, other than in a second price auction, Goethe would get to know the bid of the highest bidder. To achieve his goal, Goethe needed to be able to commit to a value that Vieweg would not get to know before

placing his bid, but such that Goethe himself would also not be able to change it. He did this by giving an envelope to a third, trusted party, Mr. Böttiger. Unfortunately, things turned out other than intended by Goethe. Böttiger opened the envelope and gave Vieweg a hint, who then bid exactly what Goethe had demanded in his envelope. Vieweg was therefore able to completely hide the information on how much he was willing to pay.

This is an example of *two-party computation*, where two players want to achieve a common goal, however they do not trust each other and do not want the other to learn more than necessary about their inputs. Obviously, such a computation can easily be achieved with the help of a trusted third party. However, as the example above shows, the two players would rather not need to trust such a third party. Our goal is therefore to achieve a two-party computation *without the help of a trusted third party*.

Unfortunately, this task is impossible to achieve *unconditionally* securely, i.e., such that even an adversary with infinite computing power has no chance in breaking the system. On the other hand, there exist implementations in the computational setting, i.e., they are secure against adversaries which only have limited computing power. However, the security of these implementations are based on unproven assumptions such as that factoring the product of two large prime numbers is hard.

Needless to say, we would like to base the security of a two-party computation protocol on as few assumptions as possible. Surprisingly, it turned out that if a very simple primitive called *oblivious transfer* is available, then *any* two party computation can be implemented in an unconditionally secure way. Oblivious transfer is a primitive that allows a sender to send two bits to a receiver, who can choose which bits he wants to receive. The receiver will remain completely ignorant about the other bit, while the sender does not get to know which bit has been chosen by the receiver.

Even though oblivious transfer is quite simple, it is rather difficult to implement. For example, in the computational setting quite strong assumptions are needed at the moment. On the other hand, it is possible to implement oblivious transfer under certain physical assumptions. However, such systems generally do not achieve a perfect oblivious transfer, but one where one or both players may still be able to cheat in some way, and obtain additional information that he should not be allowed.

The main topic of this thesis is to present different protocols that implement oblivious transfer from weaker variants. For example, in *weak oblivious transfer*, there can occur three types of errors: first, even if both players execute the protocol honestly, the output of the receiver can be wrong with some probability. Secondly, a dishonest receiver may not remain completely ignorant about the second input bit. And finally, a dishonest sender may gain partial information about the receiver's choice bit. We show that if these three errors are not too large, it is possible to implement an almost perfect oblivious transfer.

## 1.1 Background

**Two- and multi-party computation.** The concept of *two- and multi-party computation* was introduced by Yao [Yao82]. A complete solution of this problem with respect to computational security was given by Goldreich, Micali, and Wigderson [GMW87], and later but independently, by Chaum, Damgård, and van de Graaf [CDvdG88]. Later Ben-Or, Goldwasser, and Wigderson [BGW88] and, independently, Chaum, Crépeau, and Damgård [CCD88] showed that in a model with only pairwise secure channels, multi-party computation among  $n$  players unconditionally secure against an active adversary is achievable if and only if  $t < n/3$  players are corrupted. Beaver [Bea89] and independently Rabin and Ben-Or [RB89] showed that this bound can be improved to  $t < n/2$ , assuming that global broadcast channels are available.

**Security definitions.** Intuitively, it seems to be very clear what we mean when we say that a two-party protocol should be *secure*: it should be *correct*, i.e., it should implement the desired functionality, and it should be *private*, meaning that it should not leak additional information to any of the players. Unfortunately, these intuitive ad-hoc requirements are hard to formalize and often even insufficient.

Inspired by the work of Goldwasser, Micali, and Rackoff [GMR85] on zero-knowledge proofs of knowledge, Goldreich, Micali and Wigderson [GMW87] were the first to use the simulation paradigm to define the security of multi-party computation protocols. Micali and Rogaway [MR92] and Beaver [Bea92] further formalized this approach. The idea behind

these definitions is very intuitive and goes as follows. We say that a (real) protocol securely computes a certain functionality if for any adversary attacking the protocol, there exists a (not much stronger) adversary in an ideal setting — where the players only have black-box access to the functionality they try to implement — that achieves the same. In other words, a protocol is secure if any attack in the real model can be simulated in the much more restrictive ideal model. As shown by Beaver [Bea92], and formally proved by Canetti [Can96, Can00], these security definitions imply that secure protocols are *sequentially composable*: if in a secure protocol that uses an ideal functionality, that ideal functionality is replaced by a secure protocol, then the composed protocol is again a secure protocol. Later, Backes, Pfitzmann and Waidner [PW01, BPW03] and independently Canetti [Can01] introduced a stronger security definition called *universal compossibility*, which guarantees that protocols can be composed in an arbitrary way.

**Oblivious transfer.** For the special case of two-party computation, there cannot exist a protocol that is unconditionally secure against one corrupted player. However, if a primitive called *oblivious transfer (OT)* is available, then *any* two-party computation can be executed unconditionally secure, which was shown by Goldreich and Vainish [GV88] for passive adversaries, and by Kilian [Kil88] for active adversaries. These results were later improved by Crépeau [Cré90], Goldwasser and Levin [GL91], and Crépeau, van de Graaf, and Tapp [CvdGT95]. The idea of oblivious transfer goes back to Wiesner [Wie83] in around 1970. He tried to show that quantum physics allows us to achieve certain (classical) tasks that otherwise would not be possible. Since a quantum state can contain more information than what we can get out by measuring it, he proposed to use quantum communication as “*a means for transmitting two messages either but not both of which may be received.*”, which is exactly what OT achieves. More formally, OT is a primitive that receives two bits  $x_0$  and  $x_1$  from the sender and a bit  $c$  from the receiver, and sends  $x_c$  to the receiver, while the receiver does not get to know  $x_{1-c}$ , and the sender does not get to know  $c$ . Wiesner proposed a simple protocol that achieves this, but he pointed out that it could be broken in principle. Rabin [Rab81] introduced a similar primitive in 1981, and showed its usefulness to cryptographic applications. (He also gave oblivious transfer its name.) Even, Goldreich and Lempel [EGL85] reintroduced Wiesner’s version OT.



**Computationally secure oblivious transfer.** There exist different approaches to securely implement OT, with different degrees of security. If we are only interested in *computational security*, i.e., a system that cannot be broken by any adversary limited to polynomial computing time, then OT can be implemented using noiseless communication only, given some assumptions are correct. Of course, we would like to make these assumptions as weak as possible, for example, we would like to have an implementation of OT that is secure under the assumption that *one-way functions* — functions that are easy to evaluate, but hard to invert — exist. Unfortunately, such an implementation is still not known. Even worse, Impagliazzo and Rudich [IR89] showed that such an implementation, if it exists, will be very hard to find, because there cannot exist any *black-box reduction* of OT to one-way functions.

Even, Goldreich and Lempel [EGL85] presented an implementation of OT using trapdoor permutations. However, Goldreich [Gol04] showed that in fact the stronger assumption of an *enhanced trapdoor permutations* is needed for the protocol to be secure. This assumption was later weakened by Haitner [Hai04] to *dense trapdoor permutations*. Other implementations use more specific assumptions such as the assumption that factoring a product of two primes is hard, as shown by Rabin [Rab81], or the *Diffie-Hellman assumption*, shown by Bellare and Micali, Naor and Pinkas, and Aiello, Ishai and Reingold [BM90, NP01, AIR01]. Unfortunately, these latter assumptions have turned out to be wrong in the quantum world, as there exists an efficient algorithm for breaking both assumptions, shown by Shor [Sho94].

In the universally composable framework, Canetti and Fischlin [CF01] showed that there cannot exist an implementation of OT secure against active adversaries<sup>1</sup>. On the other hand, Canetti, Lindell, Ostrovsky, and Sahai [CLOS02] showed that the protocol presented in [GMW87] is secure against passive adversaries in the universally composable framework. Garay, MacKenzie and Yang [GMY04] proposed an implementation of *enhanced committed OT* secure against active adversaries under the additional assumption of a *common reference string*. Fischlin [Fis06] proposed a protocol that does not assume a common reference string, but needs the help of other players.

---

<sup>1</sup>They showed that bit-commitment is impossible, but since bit-commitment can be implemented from OT, this implies that also OT is impossible.

**Unconditionally secure oblivious transfer.** All known computational implementations of OT — besides the assumption that the adversary is computationally bounded — are based on quite strong, unproven assumptions about the complexity of certain problems. *Unconditional security* does not have these shortcomings. It offers a security that cannot be broken *in principle*, no matter what computing power the adversary has, and is generally not based on unproven assumptions. Unfortunately, unconditional secure OT is impossible to achieve if the players only have access to noiseless communication. In fact, even noiseless *quantum* communication does not help, as has been shown by Mayers [May97], and independently by Lo and Chau [LC97]<sup>2</sup>. Therefore, some additional resources must be available in order to achieve unconditionally secure OT.

**Reductions between different variants of OT.** There exist many different variants of OT, and all of them have been shown to be equivalent to OT. Crépeau [Cré88] showed that OT can be implemented from Rabin's OT, and Brassard, Crépeau and Robert [BCR86] showed, among others, that string OT (where the sender can send strings instead of single bits) can be implemented from bit OT. More efficient methods to implement string OT from bit OT were presented by Brassard, Crépeau and Sántha [BCS96], by Brassard, Crépeau and Wolf [BC97, BCW03], and by Crépeau and Savvides [CS06]. Imai, Morozov, and Nascimento [IMN06] showed a direct implementation of string OT from Rabin's OT. Dodis and Micali [DM99] presented a protocol to extend the number of choices for the receiver. Another interesting property of OT was shown by Bennett, Brassard, Crépeau and Skubiszewska [BBCS92] and Beaver [Bea95], namely that OT can be *precomputed*. This means that OT can be converted into a randomized version of OT, that can later be converted back into OT. Crépeau and Sántha [CS91], and independently Ostrovsky, Venkatesan and Yung [OY93] presented protocols which implement OT in one direction from OT in the other direction. Wolf and Wullschlegler [WW06] presented a much simpler and more efficient protocol for this.

Various weak versions of OT have been proposed where either the sender's or the receiver's security is weakened. Crépeau and Kilian [CK88] presented an implementation of OT from  $\alpha$ -1-2 *slightly OT*, which is a weak version of OT where the sender may get some information about

---

<sup>2</sup>They showed that bit-commitment is impossible, but since bit-commitment can be implemented from OT, this implies that also OT is impossible.

the choice bit of the receiver. Brassard, Crépeau and Wolf [BC97, BCW03] showed that OT can also be implemented from *XOT*, *GOT* or *UOT with repetitions*, which are weak versions of OT where the receiver may get information he is not supposed to. Cachin [Cac98] proposed a primitive called *Universal OT* (without repetitions), which is a generalization of *XOT*, *GOT* or *UOT with repetitions*. He proposed a protocol to implement OT, but his proof turned out to be incorrect. The protocol was finally shown to be secure by Damgård, Fehr, Salvail and Schaffner [DFSS06]. The bound for the protocol were later improved by Wullschleger [Wul07]. Damgård, Kilian and Salvail [DKS99] presented an even weaker form of OT called *weak OT* (WOT), where the security for *both* players is weakened and the output to the receiver may be faulty. They presented some bounds for which OT can be implemented from WOT. Later Wullschleger [Wul07] showed that their definition of WOT implicitly uses quite strong assumptions, and proposed a new, weaker definition together with new reductions.

**OT from physical assumptions.** Crépeau and Kilian [CK88] were the first to present protocols for OT using *noise* as additional resource in form of an *erasure channel*. Crépeau [Cré97] presented a protocol for the *binary-symmetric noisy channel*, which was later generalized by Korjik and Morozov [KM01]. Crépeau, Morozov and Wolf [CMW04] finally presented a protocol for *any non-trivial channel*. As shown by Imai, Müller-Quade, Nascimento and Winter, [IMQNW04], Wolf and Wullschleger [WW04], and Nascimento and Winter [NW06], these results also translate to the model where the players receive distributed randomness<sup>3</sup>.

Damgård, Kilian and Salvail [DKS99] introduced a more realistic, *unfair* model in which the adversary is given more information than the honest players. For example, if a noisy channel is implemented using a transmitter and an antenna, an adversary may be able to replace the official antenna by a larger one, and may, therefore, receive the transmitted signal with less noise than an honest receiver would. They presented explicit bounds for the *unfair binary noisy channel*, which were later improved by Damgård, Fehr, Morozov and Salvail [DFMS04, Mor05]. A central part of these results was the algorithm that implements OT from WOT. However, for the reduction to work, the definition of [Wul07] must be used.

---

<sup>3</sup>A similar model has already been studied in the context of *key agreement* by Ahlswede and Csiszár [AC93] and Maurer [Mau93].

## 1.2 Outline of the Thesis

**Preliminaries.** In Chapter 2, we introduce the three distance measures that we will be using in this thesis. We will present some of the properties they have and how they are related. The *distinguishing advantage* and the *statistical distance* are standard measures for the distance between two distributions. On the other hand, the *maximal bit-prediction advantage* is a special measure that we will use in Chapters 6 and 7.

**Definition of secure two-party computation.** In Chapter 3, we give a simplified, formal framework for two-party computation that is universally composable. We will define two different models: the malicious model, where the corrupted players may behave arbitrarily, and the semi-honest model, where the corrupted players follow the protocol, but may try to obtain as much information as they can during the protocol. We will also show that these definitions allow protocols to be composed. Finally, we show that security in the malicious model does not imply security in the semi-honest model, and give a weaker security definition for the semi-honest model for which this implication holds.

**Oblivious transfer.** In Chapter 4, we will introduce the main topic of this thesis: oblivious transfer (OT). We will also define a randomized version of OT, called *randomized OT* (ROT), and show that OT and ROT are equivalent if communication is free. We will then give a very simple protocol which shows that ROT is symmetric. In connection with the other protocols, this gives us a simple way to reverse the direction of OT. Finally, we will present *information-theoretic conditions* that imply that a protocol securely implements ROT.

*Contribution.* Our reduction that reverses ROT and hence also OT is joint work with Stefan Wolf [WW06], and is much simpler and more efficient than previous reductions presented in [CS91, OVY93]. The information-theoretic conditions for the security of ROT presented here build on prior joint work with Claude Crépeau, George Savvides and Christian Schaffner [CSSW06]. There, we presented information-theoretic conditions that imply that a protocol securely implements secure function evaluation in a sequentially composable model. These conditions replace many ad-hoc definitions for the security of protocols which often have been faulty.

Here, we only present conditions for ROT, however we show a stronger statement about ROT, as our conditions imply that a protocol is *universally composable*, and not only sequentially. Also, our conditions have explicit error terms, which makes them easier to use.

**Universal oblivious transfer.** In Chapter 5, we will present a protocol that implements ROT from a weak variant of ROT called *universal OT* (UOT). In contrast to ROT, UOT allows a corrupted receiver to receive *any* information he wants about the input, as long as he does not receive too much information. For example, he could be allowed to receive a bit string of a certain size that is an arbitrary function of his choice of the sender's inputs.

*Contribution.* Our proof, which is also presented in [Wul07], shows that in the reduction of OT to UOT, the string length of the resulting OT can be about twice as long as for the bound presented in [DFSS06], which is optimal for that protocol. (The same bound that we present here has already been claimed in [Cac98], but the proof presented there was incorrect, which was discovered by [DFSS06].) Our proof makes use of a novel *distributed leftover hash lemma*, which is a generalization of the well-known leftover hash lemma [BBR88, ILL89], and of independent interest.

**Weak oblivious transfer.** In Chapter 6, we introduce *weak oblivious transfer* (WOT), a weak variant of ROT where the security for *both* players is weak, and where the output may be incorrect. We give formal definitions of WOT in both the semi-honest and the malicious model. We show that for certain parameters (when the instances of WOT are too weak), it is impossible to implement ROT from WOT. Then we present several protocols that implement ROT from WOT, and give upper bounds on how many instances of WOT are needed. Unfortunately, these reductions do not meet the impossibility bound.

*Contribution.* We give several improvements over the results presented in [DKS99], most of which are also presented in [Wul07]. First of all, we give new, weaker definitions of WOT that replaces the definition presented in [DKS99, DFMS04], which was too strong and had only a very limited range of applications. Also, our definitions make the need for the more general notion of *generalized weak oblivious transfer* of [DFMS04] unnecessary. For the special case where the WOT does not make any error, we

present a more detailed proof and a better upper bound on the amount of instances used than in [DKS99]. Then, using a different error-reduction protocol that also works with our weaker definitions, we give bounds for the special case where information is leaked only to one of the two players, as well as several new bounds for the general case.

**Computational weak oblivious transfer.** In Chapter 7 we transfer the results from Chapter 6 to the computational setting. We define *computational weak oblivious transfer* (compWOT), which is a computational version of WOT, where the adversary may get some additional *computational* knowledge about the value he is not supposed to. Using Holenstein’s hard-core lemma [Hol05, Hol06], we show that any protocol that is secure in the information-theoretic setting can also be used in the computational setting. Hence, the reductions presented in Chapter 6 can be used to amplify compWOT to a computationally secure OT.

*Contribution.* We give a simplified but slightly stronger version of the *pseudo-randomness extraction theorem* from [Hol06], and fix the proof given in [Hol06], where a step was missing. Then, we show that computationally secure OT can be implemented from a large set of compWOT. This improves the results presented in [Hai04], where only one special case was solved.

## Chapter 2

# Preliminaries

## 2.1 Notation

We will use the following convention: lower case letters will denote fixed values and upper case letters will denote random variables and algorithms. Calligraphic letters will denote sets and domains of random variables. For a random variable  $X$  over  $\mathcal{X}$ , we denote its distribution by  $P_X : \mathcal{X} \rightarrow [0, 1]$  with  $\sum_{x \in \mathcal{X}} P_X(x) = 1$ . For a given distribution  $P_{XY} : \mathcal{X} \times \mathcal{Y} \rightarrow [0, 1]$ , we write for the marginal distribution  $P_X(x) := \sum_{y \in \mathcal{Y}} P_{XY}(x, y)$  and, if  $P_Y(y) \neq 0$ ,  $P_{X|Y}(x | y) := P_{XY}(x, y)/P_Y(y)$  for the conditional distribution. By  $x^n$  we denote the list  $(x_0, \dots, x_{n-1})$ .

We use the function  $\exp(x) := e^x$ .  $\ln(x)$  denotes the natural logarithm, and  $\log(x)$  denotes the logarithm to the base 2.

## 2.2 Distances between Distributions

In this section, we will introduce two measures for the distance between two distributions: the *distinguishing advantage* and the *statistical distance*.

**Definition 2.1.** The *distinguishing advantage* of an algorithm  $A : \mathcal{U} \rightarrow \{0, 1\}$  (called the *distinguisher*) to distinguish  $X$  from  $Y$ , which are ran-

dom variables over the domain  $\mathcal{U}$ , is

$$\text{Adv}^A(X, Y) := |\Pr[A(X) = 1] - \Pr[A(Y) = 1]| .$$

The distinguishing advantage of a class  $\mathcal{D}$  of distinguishers in distinguishing  $X$  from  $Y$  is

$$\text{Adv}^{\mathcal{D}}(X, Y) := \max_{A \in \mathcal{D}} \text{Adv}^A(X, Y) .$$

We have  $\text{Adv}^{\mathcal{D}}(X, X) = 0$  and  $\text{Adv}^{\mathcal{D}}(X, Y) = \text{Adv}^{\mathcal{D}}(Y, X)$  for all  $X$  and  $Y$ . It is also easy to see that probabilistic distinguishers do not perform better than deterministic ones: let  $A_R$  be a probabilistic distinguisher that takes additionally some randomness  $R$  as input. We have

$$\text{Adv}^{A_R}(X, Y) := \sum_r P_R(r) \cdot |\Pr[A_r(X) = 1] - \Pr[A_r(Y) = 1]| .$$

Now let  $r \in \mathcal{R}$  be the value that maximizes the expression

$$|\Pr[A_r(X) = 1] - \Pr[A_r(Y) = 1]| .$$

Then  $A_r$  is a deterministic distinguisher with

$$\text{Adv}^{A_r}(X, Y) \geq \text{Adv}^{A_R}(X, Y) .$$

In the following, we will therefore only consider deterministic distinguishers. Lemma 2.1 shows that the *triangle inequality* holds for the distinguishing advantage.

**Lemma 2.1** (Triangle inequality). *For any  $X, Y$ , and  $Z$  over  $\mathcal{U}$ , we have*

$$\text{Adv}^A(X, Z) \leq \text{Adv}^A(X, Y) + \text{Adv}^A(Y, Z) .$$

*Proof.* We have

$$\begin{aligned} \text{Adv}^A(X, Z) &= |\Pr[A(X) = 1] - \Pr[A(Z) = 1]| \\ &= |\Pr[A(X) = 1] - \Pr[A(Y) = 1] \\ &\quad + \Pr[A(Y) = 1] - \Pr[A(Z) = 1]| \\ &\leq |\Pr[A(X) = 1] - \Pr[A(Y) = 1]| \\ &\quad + |\Pr[A(Y) = 1] - \Pr[A(Z) = 1]| \\ &= \text{Adv}^A(X, Y) + \text{Adv}^A(Y, Z) . \end{aligned}$$

□



It is easy to see that the same also holds for *classes* of distinguishers, i.e., for any  $\mathcal{D}$ , we have  $\text{Adv}^{\mathcal{D}}(X, Z) \leq \text{Adv}^{\mathcal{D}}(X, Y) + \text{Adv}^{\mathcal{D}}(Y, Z)$ .

**Definition 2.2.** The *statistical distance* of two random variables  $X$  and  $Y$  (or two distributions  $P_X$  and  $P_Y$ ) over the same domain  $\mathcal{U}$  is defined as

$$\Delta(X, Y) = \Delta(P_X, P_Y) := \frac{1}{2} \sum_{u \in \mathcal{U}} \left| P_X(u) - P_Y(u) \right|.$$

We say that  $P_X$  is  $\varepsilon$ -close to  $P_Y$ , denoted by  $P_X \equiv_{\varepsilon} P_Y$ , if  $\Delta(P_X, P_Y) \leq \varepsilon$ . We say that a random variable  $X$  is  $\varepsilon$ -close to uniform with respect to  $Y$ , if  $P_{XY} \equiv_{\varepsilon} P_U P_Y$ , where  $P_U$  is the uniform distribution over  $\mathcal{X}$ .

**Lemma 2.2.** For all  $X$  and  $Y$ , we have

$$\Delta(X, Y) = \Pr[X \in \mathcal{T}] - \Pr[Y \in \mathcal{T}] = \sum_{u \in \mathcal{T}} \left( P_X(u) - P_Y(u) \right)$$

for  $\mathcal{T} := \{u \in \mathcal{U} \mid P_X(u) > P_Y(u)\}$ .

*Proof.* We have

$$\begin{aligned} \Delta(X, Y) &= \frac{1}{2} \sum_{u \in \mathcal{T}} \left( P_X(u) - P_Y(u) \right) + \frac{1}{2} \sum_{u \notin \mathcal{T}} \left( P_Y(u) - P_X(u) \right) \\ &= \frac{\Pr[X \in \mathcal{T}]}{2} + \frac{\Pr[Y \notin \mathcal{T}]}{2} - \frac{\Pr[X \notin \mathcal{T}]}{2} - \frac{\Pr[Y \in \mathcal{T}]}{2} \\ &= \Pr[X \in \mathcal{T}] - \Pr[Y \in \mathcal{T}]. \end{aligned}$$

□

**Lemma 2.3.** For all  $X$  and  $Y$ , we have

$$\Delta(X, Y) = \max_{\mathcal{S} \subseteq \mathcal{U}} \left( \Pr[X \in \mathcal{S}] - \Pr[Y \in \mathcal{S}] \right).$$

*Proof.* Follows directly from Lemma 2.2, since

$$\Pr[X \in \mathcal{S}] - \Pr[Y \in \mathcal{S}]$$

is maximal for  $\mathcal{S} = \mathcal{T}$ .

□

From Lemma 2.3 follows now that

$$\text{Adv}^{\mathcal{D}}(X, Y) = \Delta(X, Y) ,$$

where  $\mathcal{D}$  is the class of all (also inefficient) distinguishers.

**Lemma 2.4.** *For any  $X$  and  $Y$  over  $\mathcal{U}$  and  $f : \mathcal{U} \rightarrow \mathcal{V}$ , we have*

$$\Delta(f(X), f(Y)) \leq \Delta(X, Y) .$$

*Proof.* Let  $\mathcal{D}$  be the class of all (also inefficient) distinguishers, and let  $D(v)$  be a distinguisher such that

$$\text{Adv}^{\mathcal{D}}(f(X), f(Y)) = \text{Adv}^{\mathcal{D}}(f(X), f(Y)) .$$

Then, for  $D'(u) := D(f(u))$ , we have

$$\text{Adv}^{D'}(X, Y) = \text{Adv}^{\mathcal{D}}(f(X), f(Y)) .$$

Since  $D' \in \mathcal{D}$ , we have

$$\begin{aligned} \Delta(f(X), f(Y)) &= \text{Adv}^{\mathcal{D}}(f(X), f(Y)) = \text{Adv}^{D'}(X, Y) \\ &\leq \text{Adv}^{\mathcal{D}}(X, Y) = \Delta(X, Y) . \end{aligned}$$

□

**Lemma 2.5.** *Let  $P_{BX}$  and  $P_{CY}$  be distributions over  $\{0, 1\} \times \mathcal{U}$  such that*

$$\Pr[B = 1] = \Pr[C = 1] = \varepsilon .$$

*Then*

$$\Delta(P_X, P_Y) \leq \varepsilon + \Delta(P_{X|B=0}, P_{Y|C=0}) .$$

*Proof.* For any set  $\mathcal{S} \subseteq \mathcal{U}$ , we have

$$\begin{aligned} &\Pr[X \in \mathcal{S}] - \Pr[Y \in \mathcal{S}] \\ &= \varepsilon \cdot (\Pr[X \in \mathcal{S} \mid B = 1] - \Pr[Y \in \mathcal{S} \mid C = 1]) \\ &\quad + (1 - \varepsilon) \cdot (\Pr[X \in \mathcal{S} \mid B = 0] - \Pr[Y \in \mathcal{S} \mid C = 0]) \\ &\leq \varepsilon + (\Pr[X \in \mathcal{S} \mid B = 0] - \Pr[Y \in \mathcal{S} \mid C = 0]) \\ &\leq \varepsilon + \max_{\mathcal{S}' \subseteq \mathcal{U}} (\Pr[X \in \mathcal{S}' \mid B = 0] - \Pr[Y \in \mathcal{S}' \mid C = 0]) \\ &= \varepsilon + \Delta(P_{X|B=0}, P_{Y|C=0}) , \end{aligned}$$

and therefore

$$\Delta(X, Y) = \max_{S \subseteq \mathcal{U}} \left( \Pr[X \in S] - \Pr[Y \in S] \right) \leq \varepsilon + \Delta(P_{X|B=0}, P_{Y|C=0}) .$$

□

## 2.3 Prediction of Random Variables

For the case where  $X \in \{0, 1\}$ , we will also use another measure of its closeness to uniform with respect to a random variable  $Y$ , the *maximal bit-prediction advantage*, which measures how well  $X$  can be predicted from  $Y$ . See also Section 2.1 in [Hol06].

**Definition 2.3.** Let  $P_{XY}$  be a distribution over  $\{0, 1\} \times \mathcal{Y}$ . The *maximal bit-prediction advantage* of  $X$  from  $Y$  is

$$\text{PredAdv}(X | Y) := 2 \cdot \max_f \Pr[f(Y) = X] - 1 .$$

In other words, if  $\text{PredAdv}(X | Y) = \delta$ , then we have for all functions  $f : \mathcal{Y} \rightarrow \{0, 1\}$

$$\Pr[f(Y) = X] \leq \frac{1 + \delta}{2} .$$

First, we show that  $\text{PredAdv}(X | Y) \leq 2\varepsilon$ , if and only if  $X$  is  $\varepsilon$ -close to uniform with respect to  $Y$ .

**Lemma 2.6.** Let  $P_{XY}$  be a distribution over  $\{0, 1\} \times \mathcal{Y}$ . Then

$$\text{PredAdv}(X | Y) = 2 \cdot \Delta(P_{XY}, P_U P_Y) ,$$

where  $P_U$  is the uniform distribution over  $\{0, 1\}$ .

*Proof.* Obviously, the best function  $f : \mathcal{Y} \rightarrow \{0, 1\}$  for guessing  $X$  is

$$f(y) := \begin{cases} 0 & \text{if } P_{XY}(0, y) \geq P_{XY}(1, y), \\ 1 & \text{otherwise.} \end{cases}$$

We have

$$\begin{aligned}
2 \Pr[f(Y) = X] - 1 &= 2 \sum_y P_Y(y) P_{X|Y=y}(f(y)) - \sum_y P_Y(y) \\
&= \sum_y P_Y(y) (P_{X|Y=y}(f(y)) - (1 - P_{X|Y=y}(f(y)))) \\
&= \sum_y P_Y(y) (P_{X|Y=y}(f(y)) - P_{X|Y=y}(1 - f(y))) \\
&= \sum_y P_Y(y) |P_{X|Y=y}(0) - P_{X|Y=y}(1)| \\
&= \sum_y P_Y(y) \sum_x \left| P_{X|Y=y}(x) - \frac{1}{2} \right| \\
&= 2 \cdot \Delta(P_{XY}, P_U P_Y).
\end{aligned}$$

□

Lemma 2.7 follows immediately from Lemmas 2.4 and 2.6.

**Lemma 2.7.** *Let  $P_{XY}$  be a distribution over  $\{0, 1\} \times \mathcal{Y}$ , and let  $f : \mathcal{Y} \rightarrow \mathcal{Y}'$ . Then*

$$\text{PredAdv}(X | f(Y)) \leq \text{PredAdv}(X | Y).$$

The following lemma shows that for any distribution  $P_{XY}$  over  $\{0, 1\} \times \mathcal{Y}$ , we can define an event that has probability  $1 - \text{PredAdv}(X | Y)$ , such that conditioned on that event,  $X$  is uniformly distributed given  $Y$ , and therefore no function  $f(Y)$  can predict  $X$ .

**Lemma 2.8.** *Let  $P_{XY}$  be any distribution over  $\{0, 1\} \times \mathcal{Y}$ . There exists a conditional distribution  $P_{B|XY}$  over  $\{0, 1\} \times \{0, 1\} \times \mathcal{Y}$  such that*

$$\Pr[B = 1] \leq \text{PredAdv}(X | Y)$$

*and such that for all functions  $f : \mathcal{Y} \rightarrow \{0, 1\}$ ,*

$$\Pr[f(Y) = X | B = 0] = 1/2.$$

*Proof.* We define

$$P_{B|X,Y}(0 | x, y) := \frac{\min(P_{XY}(0, y), P_{XY}(1, y))}{P_{XY}(x, y)}.$$

Using Lemma 2.6, we get

$$\begin{aligned}
\Pr[B = 1] &= \sum_{x,y} P_{XY}(x,y) P_{B|X,Y}(1 | x,y) \\
&= \sum_{x,y} P_{XY}(x,y) \left( 1 - \frac{\min(P_{XY}(0,y), P_{XY}(1,y))}{P_{XY}(x,y)} \right) \\
&= \sum_{x,y} (P_{XY}(x,y) - \min(P_{XY}(0,y), P_{XY}(1,y))) \\
&= \sum_y |P_{XY}(0,y) - P_{XY}(1,y)| \\
&= \sum_y P_Y(y) \sum_x \left| P_{X|Y=y}(x) - \frac{1}{2} \right| \\
&= 2 \cdot \Delta(P_{XY}, P_U P_Y) = \text{PredAdv}(X | Y) .
\end{aligned}$$

For  $x \in \{0, 1\}$ , we have

$$\begin{aligned}
P_{X|BY}(x | 0, y) &= \frac{P_{X|Y}(x | y) \cdot P_{B|XY}(0 | x, y)}{P_{B|Y}(0 | y)} \\
&= \frac{P_{X|Y}(x | y) \cdot \min(P_{XY}(0, y), P_{XY}(1, y))}{P_{B|Y}(0 | y) \cdot P_Y(y) \cdot P_{X|Y}(x | y)} \\
&= \frac{\min(P_{XY}(0, y), P_{XY}(1, y))}{P_{BY}(0, y)} .
\end{aligned}$$

Since  $P_{X|BY}(x | 0, y)$  does not depend on  $x$ , it must be equal to  $1/2$ , and, therefore, we have, for all functions  $f$  and for all values  $y$ ,

$$\Pr[f(Y) = X | B = 0, Y = y] = 1/2 .$$

□

Lemma 2.9 shows that the statement of Lemma 2.8 also works in the other direction. If there exists an event with probability  $1 - \delta$  under which  $X$  cannot be guessed from  $Y$  with any advantage, then  $\text{PredAdv}(X | Y) \leq \delta$ .

**Lemma 2.9.** *Let  $P_{XY}$  be any distribution over  $\{0, 1\} \times \mathcal{Y}$ . If there exists a conditional distribution  $P_{B|XY}$  over  $\{0, 1\} \times \{0, 1\} \times \mathcal{Y}$  such that for all functions  $f : \mathcal{Y} \rightarrow \{0, 1\}$  we have*

$$\Pr[f(Y) = X | B = 0] = 1/2 ,$$

then

$$\text{PredAdv}(X | Y) \leq \Pr[B = 1] .$$

*Proof.* For any function  $f$ , we have

$$\begin{aligned} \Pr[f(Y) = X] &= \Pr[B = 0] \cdot \Pr[f(Y) = X | B = 0] \\ &\quad + \Pr[B = 1] \cdot \Pr[f(Y) = X | B = 1] \\ &\leq 1/2 \cdot \Pr[B = 0] + \Pr[B = 1] , \end{aligned}$$

and, therefore,

$$\begin{aligned} \text{PredAdv}(X | Y) &= 2 \cdot \max_f \Pr[f(Y) = X] - 1 \\ &\leq \Pr[B = 0] + 2 \cdot \Pr[B = 1] - 1 = \Pr[B = 1] . \end{aligned}$$

□

The following lemmas show some rules for  $\text{PredAdv}(X | Y)$ .

**Lemma 2.10.** *Let  $P_{X_0 Y_0}, \dots, P_{X_{n-1} Y_{n-1}}$  be distributions over  $\{0, 1\} \times \mathcal{Y}_i$ . Then*

$$\text{PredAdv}(X_0 \oplus \dots \oplus X_{n-1} | Y^n) \leq \prod_{i=0}^{n-1} \text{PredAdv}(X_i | Y_i) .$$

*Proof.* For  $i \in \{0, \dots, n-1\}$ , let  $B_i$  be the random variable defined by Lemma 2.8. Let  $B = \min_i(B_i)$ . If  $B = 0$  then for a  $j \in \{0, \dots, n-1\}$  we have  $B_j = 0$ . Therefore,  $X_j$  is uniformly at random given  $Y_j$ , and any  $f : \mathcal{Y}^n \rightarrow \{0, 1\}$  will output  $X_0 \oplus \dots \oplus X_{n-1}$  with probability  $1/2$ . The statement now follows from Lemma 2.9, and from the fact that

$$\Pr[B = 1] = \prod_{i=0}^{n-1} \Pr[B_i = 1] .$$

□

**Lemma 2.11.** *Let  $P_{X_0 Y_0}, \dots, P_{X_{n-1} Y_{n-1}}$  be distributions over  $\{0, 1\} \times \mathcal{Y}_i$ , and let  $D_i := X_i \oplus X_{n-1}$ . Then*

$$\text{PredAdv}(X_{n-1} | Y^n, D^{n-1}) \leq 1 - \prod_{i=0}^{n-1} (1 - \text{PredAdv}(X_i | Y_i)) .$$

*Proof.* For  $i \in \{0, \dots, n-1\}$ , let  $B_i$  be the random variable defined by Lemma 2.8, and let  $B = \max_i(B_i)$ . If  $B = 0$  then for all  $0 \leq i < n$  we have  $B_i = 0$ , and therefore  $X_i$  will be uniformly at random given  $Y_i$ . It follows that  $X_{n-1}$  is independent from  $(Y^n, D^{n-1})$  and any  $f : \mathcal{Y}^n \times \mathcal{D} \rightarrow \{0, 1\}$  will output  $X_{n-1}$  with probability  $1/2$ . The statement now follows from Lemma 2.9, and from the fact that

$$\Pr[B = 1] = 1 - \prod_{i=0}^{n-1} (1 - \Pr[B_i = 1]) .$$

□

**Lemma 2.12.** For all  $X, Y \in \{0, 1\}$  and  $Z \in \mathcal{Z}$ , we have

$$\text{PredAdv}(X \oplus Y \mid YZ) = \text{PredAdv}(X \mid YZ) .$$

*Proof.* If a function  $f(y, z)$  can predict  $X$  with advantage  $a$ , then the function  $f'(y, z) := f(y, z) \oplus y$  can predict  $X \oplus Y$  with advantage  $a$ , and if  $g(y, z)$  can predict  $X \oplus Y$  with advantage  $a$ , then the function  $g'(y, z) := g(y, z) \oplus y$  can predict  $X$  with advantage  $a$ . □





## Chapter 3

# Secure Two-Party Computation

In this chapter we give an introduction to a simplified version of *universally composable two-party computation*. We define security in the malicious and the semi-honest models, and show that these definitions allow protocols to be composed. Finally, we show that security in the malicious model does not imply security in the semi-honest model, and give a weaker security definition for the semi-honest model for which this implication holds.

### 3.1 Two-Party Computation

We start with some basic definitions. Our definitions are based on the formalism by Maurer [Mau06], as well as the formalisms of Backes, Pfitzmann and Waidner [PW01, BPW03] and Canetti [Can01], but simplified and adapted for our needs. Since we will only consider two players interacting with each other, we can simplify the notation. For example, we will not use any identification tags.

We will model everything in terms of *systems* which may interact with other systems or the environment via *interfaces*. We say that system  $\mathbf{F}$

implements a set  $\mathcal{I}$  of interfaces. There are two players present, which we will call **A** and **B**. The set of interfaces  $\mathcal{I}$  can be divided into two sets: the set  $\mathcal{I}_A$  of the interfaces belonging to player **A**, and the set  $\mathcal{I}_B$  of the interfaces belonging to player **B**.



A system has an internal, possibly infinite supply of randomness. Every output of the system is a function of the received messages so far, and the internal randomness. The system is efficient if these functions can be evaluated efficiently, i.e., using a polynomial time turing machine. The whole interaction between systems is *asynchronous*, i.e., there is no global time.

Two systems **F** and **G** can be *composed in parallel* to a new system, denoted by  $\mathbf{F}\|\mathbf{G}$ . The two sub-systems **F** and **G** do not interact with each other, and the resulting system has all the interfaces of the two subsystems.

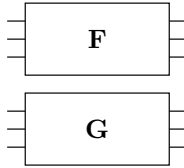

We denote the parallel composition of  $n$  times the same system **F** by  $\mathbf{F}\|n$ .

A system **G** may use another system **F** as a subsystem, which we denote by  $\mathbf{G}(\mathbf{F})$ . **G** may have some interfaces that are connected to some interfaces of **F**. We use this notation because **G** can be viewed as a function that transforms a system **F** into a system  $\mathbf{G}(\mathbf{F})$ .  $\mathbf{F}\|\mathbf{G}$  is a special case of this composition.

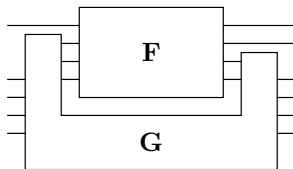

## 3.2 Distinguishing Systems

Definition 2.1 in Section 2.2, which defines the distinguishing advantage for random variables, can be generalized to systems in a straightforward way. A distinguisher is now an algorithm  $D$  that interacts with a system  $F$  and outputs 0 or 1.

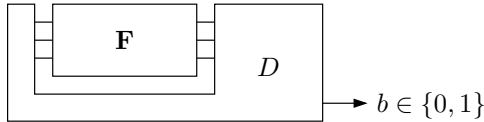

**Definition 3.1.** For two systems  $F$  and  $F'$ , the *distinguishing advantage* of a distinguisher  $D$  in distinguishing  $F$  from  $F'$  is

$$\text{Adv}^D(F, F') := |\Pr[D(F) = 1] - \Pr[D(F') = 1]|.$$

The distinguishing advantage of a class  $\mathcal{D}$  of distinguishers in distinguishing  $F$  from  $F'$  is

$$\text{Adv}^{\mathcal{D}}(F, F') := \max_{D \in \mathcal{D}} \text{Adv}^D(F, F').$$

The distinguishing advantage of systems still has the same important properties as the distinguishing advantage for random variables. Obviously, we have  $\text{Adv}^{\mathcal{D}}(F, F) = 0$  and  $\text{Adv}^{\mathcal{D}}(F', F) = \text{Adv}^{\mathcal{D}}(F, F')$ , for all  $F$  and  $F'$ . Furthermore, it also satisfies the triangle inequality:

$$\text{Adv}^{\mathcal{D}}(F, F'') \leq \text{Adv}^{\mathcal{D}}(F, F') + \text{Adv}^{\mathcal{D}}(F', F''),$$

for all  $\mathcal{D}$ ,  $F$ ,  $F'$ , and  $F''$ .

Except in Chapter 7,  $\mathcal{D}$  will be the set of all possible (also inefficient) distinguishers. In this case, we will omit the  $\mathcal{D}$  and only write  $\text{Adv}(F, F')$ . We also write  $F \equiv_{\varepsilon} F'$  for  $\text{Adv}(F, F') \leq \varepsilon$ , and  $F \equiv F'$  for  $\text{Adv}(F, F') = 0$ .

Similar to Lemma 2.4, we have for all systems  $G$ ,  $F$ , and  $F'$

$$\text{Adv}(G(F), G(F')) \leq \text{Adv}(F, F'),$$

since any distinguisher  $D$  that distinguishes  $\mathbf{G}(\mathbf{F})$  from  $\mathbf{G}(\mathbf{F}')$  with an advantage of  $\varepsilon$  can be used to distinguish  $\mathbf{F}$  from  $\mathbf{F}'$ , by first applying  $\mathbf{G}$ . If  $\mathcal{D}$  is the class of all *efficient* distinguishers, then

$$\text{Adv}^{\mathcal{D}}(\mathbf{G}(\mathbf{F}), \mathbf{G}(\mathbf{F}')) \leq \text{Adv}^{\mathcal{D}}(\mathbf{F}, \mathbf{F}'),$$

if  $\mathbf{G}$  is efficient.

Note that for the case where  $\mathbf{F}$  and  $\mathbf{F}'$  have no inputs and output random variables  $X$  and  $X'$ , respectively, this definition is equivalent to Definition 2.1, and we have

$$\text{Adv}(\mathbf{F}, \mathbf{F}') = \Delta(X, X').$$

### 3.3 Adversaries and Secure Protocols

In this section we define protocols and their security. In the following, we will often use special systems that only have interfaces for one player  $p \in \{\mathbf{A}, \mathbf{B}\}$ . We denote such systems by  $\mathbf{F}_p$ . For any systems  $\mathbf{F}_A$ ,  $\mathbf{F}_B$ , and  $\mathbf{G}$ , we have

$$\mathbf{F}_A(\mathbf{F}_B(\mathbf{G})) = \mathbf{F}_B(\mathbf{F}_A(\mathbf{G})).$$

A system of the form  $\mathbf{P}(\mathbf{F}) = (\mathbf{P}_A \parallel \mathbf{P}_B)(\mathbf{F}) = \mathbf{P}_A(\mathbf{P}_B(\mathbf{F}))$  is called a (*two-party*) *protocol*.

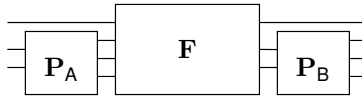

Players may be *honest*, which means that they follow the protocol, or they may be *corrupted* in two different ways. If a player is *actively corrupted*, he may behave in an arbitrary way. If a player is *passively corrupted*, then he follows the protocol, but forwards everything he sends or receives immediately over an additional interface that we will call *auxiliary interface*. Such players are also called *honest, but curious*.

The set of all corrupted players are called the *adversary*. Let

$$\mathcal{A} \subset \{\mathbf{A}, \mathbf{B}, \widehat{\mathbf{A}}, \widehat{\mathbf{B}}\}$$

be the set of corrupted players, where  $A$  and  $B$  are actively and  $\widehat{A}$  and  $\widehat{B}$  passively corrupted players. We will assume that this set is *static*, i.e., it is already determined before the protocol starts. We will not mix actively and passively corrupted players, and consider two different models. In the *malicious model*, the players may be actively corrupted, and in the *semi-honest model* the players may be passively corrupted. Furthermore, we can ignore the case where  $\mathcal{A} = \{A, B\}$  or  $\mathcal{A} = \{\widehat{A}, \widehat{B}\}$ , as we never have any requirement for these cases. Therefore, we only have to consider the case  $|\mathcal{A}| \leq 1$ .

Because an adversary may be able to use a system in a different way than the honest players, we will use the following generalized notion of a system. A *collection of systems*

$$\mathbf{F} = (\mathbf{F}_\emptyset, \mathbf{F}_{\{A\}}, \mathbf{F}_{\{B\}}), \quad \mathbf{F} = (\mathbf{F}_\emptyset, \mathbf{F}_{\{\widehat{A}\}}, \mathbf{F}_{\{\widehat{B}\}})$$

(in the malicious or the semi-honest model) defines a different system  $\mathbf{F}_\mathcal{A}$  for every possible set of corrupted players  $\mathcal{A}$ , where the honest players always have the same interfaces as in  $\mathbf{F}_\emptyset$ . This means that in  $\mathbf{F}_{\{A\}}$  and  $\mathbf{F}_{\{\widehat{A}\}}$ ,  $B$  must have the same interfaces as in  $\mathbf{F}_\emptyset$ , and in  $\mathbf{F}_{\{B\}}$  and  $\mathbf{F}_{\{\widehat{B}\}}$ ,  $A$  must have the same interfaces as in  $\mathbf{F}_\emptyset$ . Furthermore, the system  $\mathbf{F}_\mathcal{A}$  should be at least as good for the adversary as the system  $\mathbf{F}_\emptyset$ , i.e., the adversary should always be able to behave honestly.  $\mathbf{F}_\mathcal{A}$  can be interpreted as a model of a system where the adversary  $\mathcal{A}$  can corrupt a part of the system  $\mathbf{F}$ .

In the following, we will abuse the term “system”, and also use it for collections of systems.

### 3.3.1 The Malicious Model

In the *malicious model*, the adversary is allowed to cheat actively, in an arbitrary way. Therefore, we do not have any restrictions on how the interface to the adversary may look like, as long as it allows him to behave honestly, if he wants.

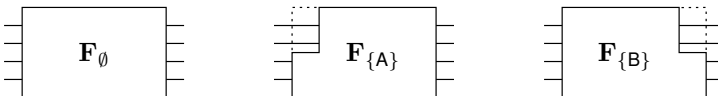

We will now define the security of protocols. We say that a protocol  $\mathbf{P}$  having access to the system  $\mathbf{F}$  securely implements a system  $\mathbf{G}$ , if, first of all,  $\mathbf{G}_\emptyset \equiv \mathbf{P}(\mathbf{F}_\emptyset)$ , i.e., the protocol implements the system  $\mathbf{G}$  correctly, given that both players are honest. Additionally, for  $\mathcal{A} = \{p\}$ , we require that the adversary attacking the protocol has no advantage over another adversary that attacks  $\mathbf{G}$  directly. We therefore require that there exists a *simulator*  $\mathbf{S}_p$  that simulates exactly what the adversary would get in the execution of the protocol  $\mathbf{P}(\mathbf{F})$ . Since the adversary may not follow the protocol, his view of the protocol is in fact the “raw” interface of  $\mathbf{F}$ , without his part of the protocol.

**Definition 3.2.** A protocol  $\mathbf{P}(\mathbf{F}) = (\mathbf{P}_A \parallel \mathbf{P}_B)(\mathbf{F})$  *securely implements a system  $\mathbf{G}$  in the malicious model with an error of at most  $\varepsilon$* , if

- (Correctness)  $\mathbf{P}(\mathbf{F}_\emptyset) \equiv_\varepsilon \mathbf{G}_\emptyset$ .
- (Security for A) There exists a system  $\mathbf{S}_B$  (called *the simulator for B*), such that

$$\mathbf{P}_A(\mathbf{F}_{\{B\}}) \equiv_\varepsilon \mathbf{S}_B(\mathbf{G}_{\{B\}}).$$

- (Security for B) There exists a system  $\mathbf{S}_A$  (called *the simulator for A*), such that

$$\mathbf{P}_B(\mathbf{F}_{\{A\}}) \equiv_\varepsilon \mathbf{S}_A(\mathbf{G}_{\{A\}}).$$

Note that the protocol  $\mathbf{P}(\mathbf{F})$  can also be viewed as a new system  $\mathbf{E}$ , defined by  $\mathbf{E}_\emptyset := \mathbf{P}(\mathbf{F}_\emptyset)$ ,  $\mathbf{E}_{\{B\}} := \mathbf{P}_A(\mathbf{F}_{\{B\}})$ , and  $\mathbf{E}_{\{A\}} := \mathbf{P}_B(\mathbf{F}_{\{A\}})$ . Definition 3.2 could then be stated by comparing the systems  $\mathbf{E}$  and  $\mathbf{G}$ .

We do generally not require the simulation to be efficient. Therefore, an attack that is efficient in  $\mathbf{P}(\mathbf{F})$  may be mapped to a very inefficient attack in  $\mathbf{G}$ . This means that if the system  $\mathbf{G}$  is replaced by the protocol  $\mathbf{P}(\mathbf{F})$ , the adversary may gain extra possibilities because he may be able to execute some attacks more efficiently in the new setting. More precisely, he gains the extra possibility of executing the simulator for free. Depending on the setting, this may be a problem. For example, if the simulator allows him to invert a one-way function, a system that relies on the assumption that inverting this one-way function is hard may not be secure anymore. On the other hand, if  $\mathbf{P}(\mathbf{F})$  is used in a protocol that is information-theoretically secure, the additional, virtual computing power of the adversary will be of little use to him. Therefore, an efficient simulation is preferable, even in the model where the adversary

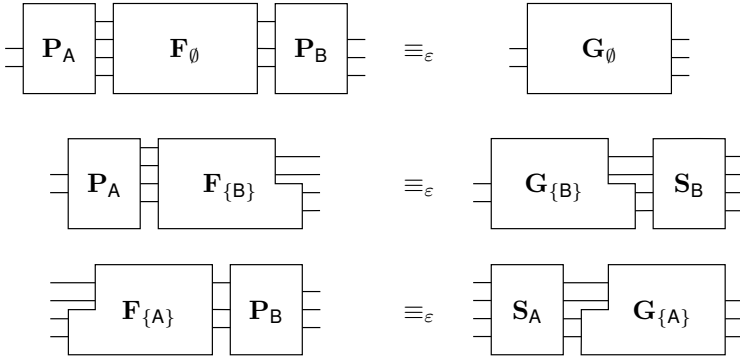

**Figure 3.1:** The three conditions for the security in the malicious model of a protocol  $\mathbf{P} = (\mathbf{P}_A \parallel \mathbf{P}_B)$  that uses  $\mathbf{F} = (\mathbf{F}_\emptyset, \mathbf{F}_{\{B\}}, \mathbf{F}_{\{A\}})$  and implements  $\mathbf{G} = (\mathbf{G}_\emptyset, \mathbf{G}_{\{A\}}, \mathbf{G}_{\{B\}})$ .

is (potentially) unbounded, because it allows the protocol to be used also in the computational setting. A very important property of this security definition is that it allows protocols to be *composed*.

**Theorem 3.1** (Composition theorem, malicious model). *If  $\mathbf{P}(\mathbf{F})$  securely implements  $\mathbf{G}$  in the malicious model with an error of at most  $\varepsilon_1$ , and  $\mathbf{Q}(\mathbf{H})$  securely implements  $\mathbf{F}$  in the malicious model with an error of at most  $\varepsilon_2$ , then  $\mathbf{P}(\mathbf{Q}(\mathbf{H}))$  securely implements  $\mathbf{G}$  in the malicious model with an error of at most  $\varepsilon_1 + \varepsilon_2$ .*

*Proof.* From  $\mathbf{Q}(\mathbf{H}_\emptyset) \equiv_{\varepsilon_2} \mathbf{F}_\emptyset$  follows that  $\mathbf{P}(\mathbf{Q}(\mathbf{H}_\emptyset)) \equiv_{\varepsilon_2} \mathbf{P}(\mathbf{F}_\emptyset)$ . Since  $\mathbf{P}(\mathbf{F}_\emptyset) \equiv_{\varepsilon_1} \mathbf{G}_\emptyset$ , it follows from the triangle inequality that

$$\mathbf{P}(\mathbf{Q}(\mathbf{H}_\emptyset)) \equiv_{\varepsilon_1 + \varepsilon_2} \mathbf{G}_\emptyset .$$

There exists a simulator  $\mathbf{S}_B$ , such that  $\mathbf{Q}_A(\mathbf{H}_{\{B\}}) \equiv_{\varepsilon_2} \mathbf{S}_B(\mathbf{F}_{\{B\}})$ . It follows that

$$\mathbf{P}_A(\mathbf{Q}_A(\mathbf{H}_{\{B\}})) \equiv_{\varepsilon_2} \mathbf{P}_A(\mathbf{S}_B(\mathbf{F}_{\{B\}})) = \mathbf{S}_B(\mathbf{P}_A(\mathbf{F}_{\{B\}})) .$$

Since there exists a simulator  $\mathbf{T}_B$  such that  $\mathbf{P}_A(\mathbf{F}_{\{B\}}) \equiv_{\varepsilon_1} \mathbf{T}_B(\mathbf{G}_{\{B\}})$ , we have

$$\mathbf{S}_B(\mathbf{P}_A(\mathbf{F}_{\{B\}})) \equiv_{\varepsilon_1} \mathbf{S}_B(\mathbf{T}_B(\mathbf{G}_{\{B\}})) .$$

It follows from the triangle inequality that

$$\mathbf{P}_A(\mathbf{Q}_A(\mathbf{H}_{\{B\}})) \equiv_{\varepsilon_1 + \varepsilon_2} \mathbf{S}_B(\mathbf{T}_B(\mathbf{G}_{\{B\}})),$$

and hence the protocol is secure for  $A$ , with an error of at most  $\varepsilon_1 + \varepsilon_2$ . The security for  $B$  can be shown in the same way.  $\square$

### 3.3.2 The Semi-Honest Model

In the *semi-honest model*, the adversary is *passive*. Instead of executing  $\mathbf{P}_p$ , a passively corrupted player  $p$  executes  $\underline{\mathbf{P}}_p$ , which is equal to  $\mathbf{P}_p$ , but forwards everything it sends or receives immediately over an auxiliary interface. Note that the output of the auxiliary interface contains the entire *view* of the corrupted player, and therefore also the output of the honest interface.



We require that every system in a collection must also have the same interfaces for the adversary as for the honest player, because the adversary executes the protocol honestly and can only connect to these interfaces. However, the system has auxiliary output interfaces for the adversary, that provide him with some extra information.

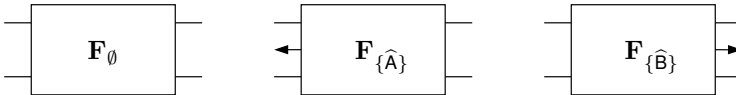

Let  $\mathcal{A} = \{\hat{p}\}$ . A protocol  $\mathbf{P}(\mathbf{F})$  securely implements a system  $\mathbf{G}$  in the semi-honest model if there exists a simulator  $\mathbf{S}_p$  that accesses the interaction of the system  $\mathbf{G}_{\{\hat{p}\}}$  with player  $p$  and produces the same output as  $\underline{\mathbf{P}}_p$ . Furthermore, the simulator  $\mathbf{S}_p$  is not allowed to modify the inputs and outputs on the interfaces of the honest player, because we require that the simulated adversary attacking  $\mathbf{G}$  is also only passively, and not actively corrupted. Otherwise, the protocol could not be composed. We get the following definition.



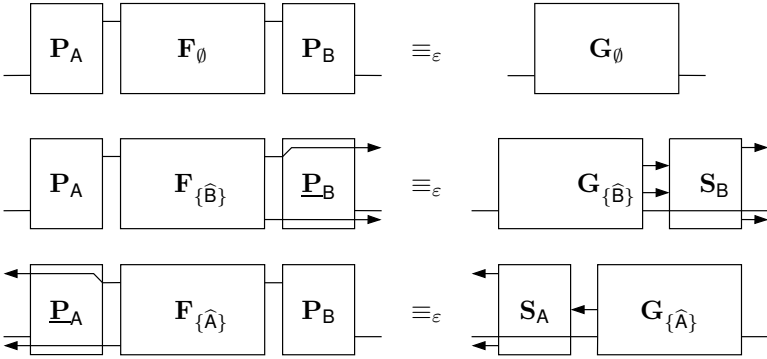

**Figure 3.2:** The three conditions for the security in the semi-honest model of a two-party protocol  $\mathbf{P} = (\mathbf{P}_A \parallel \mathbf{P}_B)$  that uses  $\mathbf{F} = (\mathbf{F}_\emptyset, \mathbf{F}_{\{\hat{A}\}}, \mathbf{F}_{\{\hat{B}\}})$  and implements  $\mathbf{G} = (\mathbf{G}_\emptyset, \mathbf{G}_{\{\hat{A}\}}, \mathbf{G}_{\{\hat{B}\}})$ .

**Definition 3.3.** A protocol  $\mathbf{P}(\mathbf{F}) = (\mathbf{P}_A \parallel \mathbf{P}_B)(\mathbf{F})$  securely implements  $\mathbf{G}$  in the semi-honest model with an error of at most  $\varepsilon$ , if

- (Correctness)  $\mathbf{P}(\mathbf{F}_\emptyset) \equiv_\varepsilon \mathbf{G}_\emptyset$ .
- (Security for A) There exists a system  $\mathbf{S}_B$  (called *the simulator for B*), that only modifies the auxiliary interfaces, such that

$$(\mathbf{P}_A \parallel \underline{\mathbf{P}}_B)(\mathbf{F}_{\{\hat{B}\}}) \equiv_\varepsilon \mathbf{S}_B(\mathbf{G}_{\{\hat{B}\}}).$$

- (Security for B) There exists a system  $\mathbf{S}_A$  (called *the simulator for A*), that only modifies the auxiliary interfaces, such that

$$(\underline{\mathbf{P}}_A \parallel \mathbf{P}_B)(\mathbf{F}_{\{\hat{A}\}}) \equiv_\varepsilon \mathbf{S}_A(\mathbf{G}_{\{\hat{A}\}}).$$

As in the malicious model, we can show that protocols in the semi-honest model compose.

**Theorem 3.2** (Composition theorem, semi-honest model). *If  $\mathbf{P}(\mathbf{F})$  securely implements  $\mathbf{G}$  in the semi-honest model with an error of at most  $\varepsilon_1$ , and  $\mathbf{Q}(\mathbf{H})$  securely implements  $\mathbf{F}$  in the semi-honest model with an error of at most  $\varepsilon_2$ , then  $\mathbf{P}(\mathbf{Q}(\mathbf{H}))$  securely implements  $\mathbf{G}$  in the semi-honest model with an error of at most  $\varepsilon_1 + \varepsilon_2$ .*

*Proof sketch.* From  $\mathbf{Q}(\mathbf{H}_\emptyset) \equiv_{\varepsilon_2} \mathbf{F}_\emptyset$  follows that  $\mathbf{P}(\mathbf{Q}(\mathbf{H}_\emptyset)) \equiv_{\varepsilon_2} \mathbf{P}(\mathbf{F}_\emptyset)$ . Since  $\mathbf{P}(\mathbf{F}_\emptyset) \equiv_{\varepsilon_1} \mathbf{G}_\emptyset$ , it follows from the triangle inequality that

$$\mathbf{P}(\mathbf{Q}(\mathbf{H}_\emptyset)) \equiv_{\varepsilon_1 + \varepsilon_2} \mathbf{G}_\emptyset .$$

There exists a simulator  $\mathbf{S}_B$ , such that  $(\mathbf{Q}_A \parallel \underline{\mathbf{Q}}_B)(\mathbf{H}_{\{\widehat{B}\}}) \equiv_{\varepsilon_2} \mathbf{S}_B(\mathbf{F}_{\{\widehat{B}\}})$ . It follows that

$$(\mathbf{P}_A \parallel \underline{\mathbf{P}}_B)((\mathbf{Q}_A \parallel \underline{\mathbf{Q}}_B)(\mathbf{H}_{\{\widehat{B}\}})) \equiv_{\varepsilon_2} (\mathbf{P}_A \parallel \underline{\mathbf{P}}_B)(\mathbf{S}_B(\mathbf{F}_{\{\widehat{B}\}})) .$$

Note that  $\underline{\mathbf{P}}_B$  passes all its communication to  $\mathbf{B}$ , and  $\mathbf{S}_B$  only modifies the additional output, but leaves the messages of the honest player unchanged. Furthermore, all messages that  $\mathbf{S}_B$  sees will be passed along by the protocol  $\underline{\mathbf{P}}_B$ . Hence, we can move  $\mathbf{S}_B$  to the outside, i.e.,

$$(\mathbf{P}_A \parallel \underline{\mathbf{P}}_B)(\mathbf{S}_B(\mathbf{F}_{\{\widehat{B}\}})) = \mathbf{S}_B((\mathbf{P}_A \parallel \underline{\mathbf{P}}_B)(\mathbf{F}_{\{\widehat{B}\}})) .$$

Since there exists a simulator  $\mathbf{T}_B$  such that  $(\mathbf{P}_A \parallel \underline{\mathbf{P}}_B)(\mathbf{F}_{\{\widehat{B}\}}) \equiv_{\varepsilon_1} \mathbf{T}_B(\mathbf{G}_{\{\widehat{B}\}})$ , we have

$$\mathbf{S}_B((\mathbf{P}_A \parallel \underline{\mathbf{P}}_B)(\mathbf{F}_{\{\widehat{B}\}})) \equiv_{\varepsilon_1} \mathbf{S}_B(\mathbf{T}_B(\mathbf{G}_{\{\widehat{B}\}})) .$$

It follows from the triangle inequality that

$$(\mathbf{P}_A \parallel \underline{\mathbf{P}}_B)((\mathbf{Q}_A \parallel \underline{\mathbf{Q}}_B)(\mathbf{H}_{\{\widehat{B}\}})) \equiv_{\varepsilon_1 + \varepsilon_2} \mathbf{S}_B(\mathbf{T}_B(\mathbf{G}_{\{\widehat{B}\}})) = (\mathbf{S}_B(\mathbf{T}_B))(\mathbf{G}_{\{\widehat{B}\}}) .$$

Since  $\mathbf{S}_B(\mathbf{T}_B)$  only modifies the auxiliary output, it is a valid simulator, and hence the protocol is secure for  $\mathbf{A}$  with an error of at most  $\varepsilon_1 + \varepsilon_2$ . The security for  $\mathbf{B}$  can be shown in the same way.  $\square$

**From passive to active security.** Since security against passively corrupted players is quite weak in practice, it is preferable to have a protocol that is secure against active adversaries. [GMW87] showed that it is possible to convert any protocols that is secure in the semi-honest model into a protocol that is secure in the malicious model, by forcing all players to follow the protocol. To achieve this, every player must commit himself to all the values he has, and in every step of the protocols, he must proof in zero-knowledge that he has executed the computation correctly. We will not further comment on this method, and refer to [GMW87, Cré90, CvdGT95, DKS99, CLOS02, DFMS04] for any details.

### 3.3.3 The Weak Semi-Honest Model

We would expect that every protocol that is secure in the malicious model is also secure in the semi-honest model, since the adversary is restricted in the latter case. Unfortunately, this is not always true. The security condition in the malicious model only tells us that for any (also semi-honest) adversary, there exists a *malicious* adversary for the ideal system. On the other hand, the security condition in the semi-honest model requires the adversary for the ideal system to be *semi-honest*. The following example, which we call the *asymmetric dating problem*, illustrates the difference.

**Example 1** (The asymmetric dating problem). Let the system  $\mathbf{F}$  be defined as follows. It receives a value  $x \in \{0, 1\}$  from  $\mathbf{A}$ , and a value  $y \in \{0, 1\}$  from  $\mathbf{B}$ . Then, it outputs  $z := x \cdot y$  to  $\mathbf{B}$ .

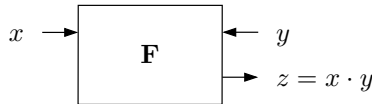

Let  $\text{Comm}$  be a communication channel, and let the protocol  $\mathbf{P}(\text{Comm})$  be defined as follows.  $\mathbf{P}_\mathbf{A}$  receives input  $x \in \{0, 1\}$  and sends  $x$  over  $\text{Comm}$  to  $\mathbf{B}$ .  $\mathbf{P}_\mathbf{B}$  receives input  $y \in \{0, 1\}$  from  $\mathbf{B}$  and  $x$  over  $\text{Comm}$  and outputs  $z := x \cdot y$ . Let us look at the security for  $\mathbf{A}$ . It is easy to see that  $\mathbf{P}(\text{Comm})$  securely implements  $\mathbf{F}$  in the malicious model, since the simulator  $\mathbf{S}_\mathbf{B}$  can always input  $y = 1$  to  $\mathbf{F}$  and obtain the same information as in  $\mathbf{P}(\mathbf{F})$ . However, the protocol  $\mathbf{P}(\text{Comm})$  is *not secure in the semi-honest model*. Since the simulator  $\mathbf{S}_\mathbf{B}$  is not allowed to change the value  $y$ ,  $\mathbf{S}_\mathbf{B}$  cannot simulate  $x$  if  $y = 0$ .

We will now present a weaker security definition for the semi-honest model that is also strictly weaker than the security definition of the malicious model. The only difference to Definition 3.3 is that we allow arbitrary simulators, i.e., the simulator may modify the inputs as it likes.

**Definition 3.4.** A protocol  $\mathbf{P}(\mathbf{F}) = (\mathbf{P}_\mathbf{A} \parallel \mathbf{P}_\mathbf{B})(\mathbf{F})$  securely implements  $\mathbf{G}$  in the weak semi-honest model with an error of at most  $\varepsilon$ , if

- (Correctness)  $\mathbf{P}(\mathbf{F}_\emptyset) \equiv_\varepsilon \mathbf{G}_\emptyset$ .

- (Security for A) There exists a system  $S_B$  (called *the simulator for B*), such that

$$(\mathbf{P}_A \parallel \underline{\mathbf{P}}_B)(\mathbf{F}_{\{\widehat{B}\}}) \equiv_\varepsilon S_B(\mathbf{G}_{\{B\}}) .$$

- (Security for B) There exists a system  $S_A$  (called *the simulator for A*), such that

$$(\underline{\mathbf{P}}_A \parallel \mathbf{P}_B)(\mathbf{F}_{\{\widehat{A}\}}) \equiv_\varepsilon S_A(\mathbf{G}_{\{A\}}) .$$

**Lemma 3.1.** *If a protocol  $\mathbf{P}(\mathbf{F}) = (\mathbf{P}_A \parallel \mathbf{P}_B)(\mathbf{F})$  securely implements  $\mathbf{G}$  in the semi-honest model or in the malicious model with an error of at most  $\varepsilon$ , then it also securely implements  $\mathbf{G}$  in the weak semi-honest model with an error of at most  $\varepsilon$ .*

*Proof.* It is obvious that security in the semi-honest model implies security in the weak semi-honest model.

Let us assume that  $\mathbf{P}(\mathbf{F}) = (\mathbf{P}_A \parallel \mathbf{P}_B)(\mathbf{F})$  securely implements  $\mathbf{G}$  in the malicious model. The correctness conditions in the weak semi-honest model is the same as in the malicious model.

From the security for A follows that there exists a simulator  $S_B$ , such that

$$\mathbf{P}_A(\mathbf{F}_{\{B\}}) \equiv_\varepsilon S_B(\mathbf{G}_{\{B\}}) .$$

Therefore, we have

$$(\mathbf{P}_A \parallel \underline{\mathbf{P}}_B)(\mathbf{F}_{\{B\}}) = \underline{\mathbf{P}}_B(\mathbf{P}_A(\mathbf{F}_{\{B\}})) \equiv_\varepsilon \underline{\mathbf{P}}_B(S_B(\mathbf{G}_{\{B\}})) = (\underline{\mathbf{P}}_B(S_B))(\mathbf{G}_{\{B\}}) .$$

The system  $\mathbf{T}_B := \underline{\mathbf{P}}_B(S_B)$  is a simulator, which implies security for A in the weak semi-honest model. The security for B can be shown in the same way.  $\square$

Unfortunately, Definition 3.4 is too weak to allow for composition, and is therefore not a very useful definition for the security of protocols. The only composition that is possible is the following, where the outer protocol is secure in the weak semi-honest model, and the inner protocol is secure in the semi-honest model.

**Theorem 3.3** (Simple composition theorem, weak semi-honest model). *If  $\mathbf{P}(\mathbf{F})$  securely implements  $\mathbf{G}$  in the weak semi-honest model with an error of at most  $\varepsilon_1$ , and  $\mathbf{Q}(\mathbf{H})$  securely implements  $\mathbf{F}$  in the semi-honest model with an error of at most  $\varepsilon_2$ , then  $\mathbf{P}(\mathbf{Q}(\mathbf{H}))$  securely implements  $\mathbf{G}$  in the weak semi-honest model with an error of at most  $\varepsilon_1 + \varepsilon_2$ .*

*Proof sketch.* The proof can be done in the same way as the proof of Theorem 3.2. The only difference is that now, the simulator  $T_B$  is not restricted in any way. The argument works in the same way, except that the resulting simulator  $S_B(T_B)$  will not be restricted either. Hence, the protocol is secure in the weak semi-honest model.  $\square$

The weak semi-honest model is useful to prove impossibilities, since it is weaker than the definitions in both the malicious and the semi-honest models. If we can show that there cannot exist a protocol in the weak semi-honest model, then there can neither exist a protocol secure in the malicious, nor in the semi-honest model.

## 3.4 Discussion

In this chapter we presented a simplified universally composable framework for two-party computation. We did not use the frameworks presented in [PW01, BPW03] or [Can01] because they are far too complex and too general for what we will need them. Our simplified framework will make the results in the following chapters easier to state, and hopefully also easier to understand. However, this also means that in order to fit our results into more general frameworks such as [PW01, BPW03] or [Can01], additional work will be needed.

If our protocols are to be executed in an environment where more players are present, we have to make sure that all the other players do not get any information over the inputs or the outputs of  $A$  and  $B$ . This can be achieved by requiring that all our two-party systems are completely independent of the other players. This means for example that all channels must be secure and authentic.



## Chapter 4

# Oblivious Transfer

In this chapter we introduce the primitives oblivious transfer (OT) and randomized oblivious transfer (ROT), which is a variant of OT where the inputs of the honest players are chosen at random.

We start by showing that OT and ROT are equivalent if noiseless communication is available for free. Then, we show that ROT is symmetric by presenting a protocol that converts an instance of ROT into an instance of ROT in the opposite direction. This implies that also the direction of OT can be reversed in a very simple way (Theorem 4.1).

In Theorems 4.2 and 4.3 we give information-theoretic conditions for the security of ROT. These conditions are similar to the ones presented in [CSSW06], however we are able to show a stronger result, as our conditions imply that a protocol which satisfies them is *universally composable*, and not only sequentially. Also, our conditions have explicit error terms, which makes them easier to use.

All the results will be stated in the malicious and the semi-honest model.

## 4.1 (Randomized) Oblivious Transfer

In this section we will introduce *oblivious transfer (OT)*, and a randomized version of OT called *randomized OT (ROT)*.

**Definition 4.1** (Oblivious transfer). The system  $\binom{n}{1}$ -OT $^\ell$  (or, if the values of  $n$  and  $\ell$  are clear from the context, OT) is defined as follows. First, it waits for B to send his input  $c \in \{0, \dots, n-1\}$ , and sends A  $\perp^1$ . After having received input  $x^n = (x_0, \dots, x_{n-1}) \in \{0, 1\}^{\ell \cdot n}$  from A, it sends  $y := x_c$  to B. (Notice that  $\text{OT} = \text{OT}_\emptyset = \text{OT}_{\{A\}} = \text{OT}_{\{B\}}$ .)



(Note that from now on, the drawings will also include timing aspects. The time flows from the top to the bottom. The dotted lines indicate waiting points, where the system waits to receive all messages above the line before it continues.)

We use the same version of OT as [CLOS02], where the sender is notified about the fact that the receiver has made his choice. Notice that in [Can01, Fis06], OT has been defined differently. There, the honest sender does not get this notification. We do not know how to securely implement OT if the malicious sender does not get to know the fact that the receiver has made his choice. Therefore, it is preferable to also give this information to the honest sender. For example, this allows us to easily implement a bit-commitment protocol from the receiver to the sender. Also, only this definition allows us to show that OT and ROT are equivalent if noiseless communication is available for free.

Often, it is much easier to implement a randomized version of OT, called *randomized oblivious transfer (ROT)*, first. One way of defining ROT would be to make it equivalent to OT, but where all the inputs are chosen uniformly at random by the system. This definition would, however, not be very useful, because it is too strong: any secure implementation would

<sup>1</sup>This is a message without any content, which notifies A about the fact that B has sent his input  $c$ .



have to make sure that all values are indeed chosen uniformly at random, which can be very difficult. Furthermore, it turns out that in most applications this is not needed. We will, therefore, define ROT as a collection of systems, where the adversary can choose her own output.

**Definition 4.2** (Randomized oblivious transfer, malicious model). The system  $\binom{n}{1}$ -ROT<sup>ℓ</sup> (or, if the values of  $n$  and  $\ell$  are clear from the context, ROT) is defined as a collection of systems

$$\text{ROT} = (\text{ROT}_{\emptyset}, \text{ROT}_{\{A\}}, \text{ROT}_{\{B\}}),$$

where

- ROT<sub>∅</sub>: The system chooses uniformly at random the value  $x^n \in \{0, 1\}^{\ell \cdot n}$  and  $c \in \{0, \dots, n - 1\}$ . It sends  $x^n$  to A and  $(c, y)$  to B where  $y = x_c$ .
- ROT<sub>{A}</sub>: The system waits for A to send the value  $x^n \in \{0, 1\}^{\ell \cdot n}$ . Then, it chooses the value  $c \in \{0, \dots, n - 1\}$  uniformly at random and sends  $(c, y)$  to B, where  $y = x_c$ .
- ROT<sub>{B}</sub>: The system waits for B to send the value  $(c, y) \in \{0, \dots, n - 1\} \times \{0, 1\}^\ell$ . Then, it sets  $x_c = y$ , chooses the values  $x_i \in \{0, 1\}^\ell$  uniformly at random for  $i \neq c$ , and sends  $x^n \in \{0, 1\}^{\ell \cdot n}$  to A.

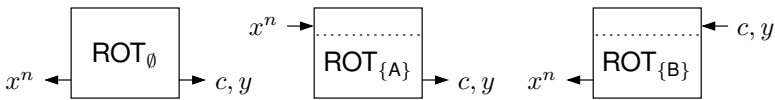

We will now show that OT and ROT are equivalent if communication is given for free, by presenting two protocols that securely implement one system using one instance of the other and a communication channel.

Protocol ROTfromOT = ROTfromOT<sub>A</sub> || ROTfromOT<sub>B</sub> securely implements ROT from one instance of OT, and is defined as follows.

**Protocol 1.** ROTfromOT<sub>A</sub>:

1. Choose  $x^n \in \{0, 1\}^{\ell \cdot n}$  uniformly at random.
2. Send  $x^n$  to OT.

3. Receive  $\perp$  from OT.
4. Output  $x^n$ .

ROTfromOT<sub>B</sub>:

1. Choose  $c \in \{0, \dots, n-1\}$  uniformly at random.
2. Send  $c$  to OT.
3. Receive  $y \in \{0, 1\}^\ell$  from OT.
4. Output  $(c, y)$ .

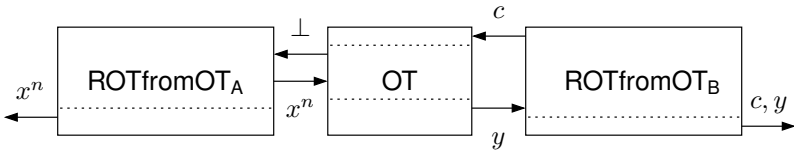

**Lemma 4.1.** *ROTfromOT( $\binom{n}{1}$ -OT<sup>ℓ</sup>) securely implements  $\binom{n}{1}$ -ROT<sup>ℓ</sup> in the malicious model.*

*Proof.* Obviously, we have  $\text{ROT}_\emptyset \equiv \text{ROTfromOT}(\text{OT})$ .

ROTfromOT<sub>A</sub>(OT) waits for input  $c$  from B, and then outputs  $x^n$  to A, where all  $x_i$  are chosen uniformly at random and independently of the rest, and  $y := x_c$  to B. We define  $S_B$  as follows. It waits for input  $c$  from B. Then it chooses  $y \in \{0, 1\}^\ell$  uniformly at random, sends  $(c, y)$  to ROT<sub>{B}</sub>, and outputs  $y$ .

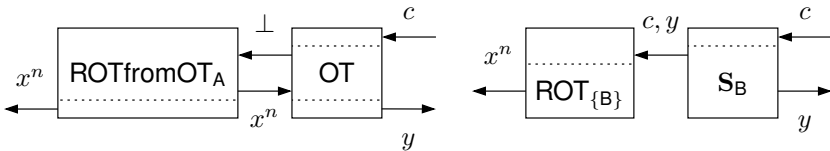

It is easy to verify that  $\text{ROTfromOT}_A(\text{OT}) \equiv S_B(\text{ROT}_{\{B\}})$ .

$\text{ROTfromOT}_B(\text{OT})$  outputs  $\perp$  to A. It waits for input  $x^n$  from A, chooses a value  $c \in \{0, \dots, n-1\}$  uniformly at random, and sends  $c$  and  $y := x_c$  to B. We define  $\text{S}_A$  as follows. It outputs  $\perp$  to A. It waits for input  $x^n$  from A and sends it to  $\text{ROT}_{\{A\}}$ .

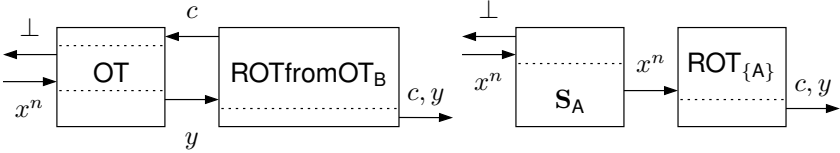

It is easy to verify that  $\text{ROTfromOT}_B(\text{OT}) \equiv \text{S}_A(\text{ROT}_{\{A\}})$ . □

To implement OT from ROT, A and B need to be able to communicate. We will therefore additionally need the system  $\text{Comm}$ , which implements a communication channel from A to B and from B to A. Note that, in contrast to OT or ROT,  $\text{Comm}$  can be used many times.

**Definition 4.3 (Channel).** The system  $\text{Comm}$  is defined as follows. Every time it receives a message  $m \in \{0, 1\}^*$  from  $p \in \{A, B\}$ , it sends it to the other player in  $\{A, B\}$ .

We can now state the protocol  $\text{OTfromROT}$ , which was first proposed in [BBCS92] to securely implements OT using ROT and  $\text{Comm}$ . The protocol is defined as follows.

**Protocol 2.**  $\text{OTfromROT}_A$ :

1. Receive  $d \in \{0, \dots, n-1\}$  from  $\text{Comm}$  and  $(x')^n \in \{0, 1\}^{\ell \cdot n}$  from ROT.
2. Output  $\perp$  to A.
3. Receive  $x^n \in \{0, 1\}^{\ell \cdot n}$  from A.
4. Send  $m^n \in \{0, 1\}^{\ell \cdot n}$  to  $\text{Comm}$ , where  $m_i := x_i \oplus x'_{i+d \pmod n}$ .

$\text{OTfromROT}_B$ :

1. Receive  $c \in \{0, \dots, n-1\}$  from B and  $(c', y') \in \{0, \dots, n-1\} \times \{0, 1\}^\ell$  from ROT.
2. Send  $d := c' - c \pmod{n}$  to Comm.
3. Receive  $m^n \in \{0, 1\}^{\ell \cdot n}$  from Comm.
4. Output  $y := m_c \oplus y'$  to B.

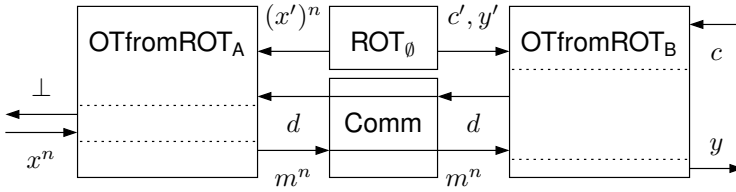

**Lemma 4.2.**  $ROTfromOT(\binom{n}{1}-ROT^\ell \parallel Comm)$  securely implements  $\binom{n}{1}-OT^\ell$  in the malicious model.

*Proof.*  $OTfromROT(ROT_\emptyset \parallel Comm)$  waits for input  $c$  from B, and sends  $\perp$  to A. After receiving  $x^n$  from A, it sends

$$\begin{aligned} y &= m_c \oplus y' = x_c \oplus x'_{c+d \pmod{n}} \oplus y' = x_c \oplus x'_{c+c'-c \pmod{n}} \oplus y' \\ &= x_c \oplus x'_c \oplus y' = x_c \end{aligned}$$

to B. (We used the fact that  $y' = x'_c$ .) Hence, we have

$$OT \equiv OTfromROT(ROT_\emptyset \parallel Comm).$$

$OTfromROTA(ROT_{\{B\}} \parallel Comm)$  waits for  $(c', y')$  and  $d$  from B, and then outputs  $\perp$  to A. It then waits for its input  $x^n$  from A and outputs  $m^n$  to B, where  $m_{c'-d} = x_{c'-d} \oplus y'$ , and all the other values  $m_i$  are uniformly distributed and independent of the rest. We define  $S_B$  as follows. It waits for input  $(c', y')$  on the  $ROT_{\{B\}}$  interface, and  $d$  on the  $Comm$  interface. Then it sends  $c := c' - d$  to OT. It receives  $y = x_{c'-d}$  from OT, sets  $m_{c'-d} := y \oplus y'$  and chooses all other  $m_i$  uniformly at random. Finally, it outputs  $m^n$  on the  $Comm$  interface.

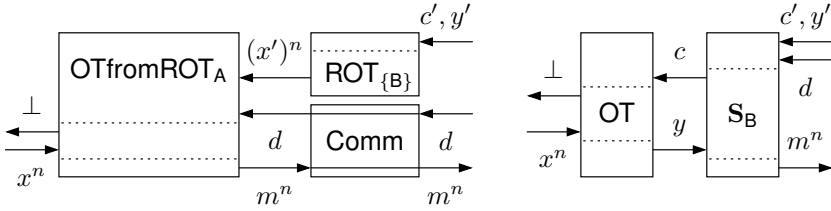

It is easy to verify that  $\text{OTfromROT}_A(\text{ROT}_{\{B\}} \parallel \text{Comm}) \equiv \text{S}_B(\text{OT})$ .

$\text{OTfromROT}_B(\text{ROT}_{\{A\}} \parallel \text{Comm})$  waits for  $(x')^n$  from the ROT interface, and the input  $c$  from B. It chooses  $d$  uniformly at random and sends it to A. After receiving also  $m^n$  from the Comm interface from A, it outputs  $y = m_c \oplus y' = m_c \oplus x'_{c+d \pmod n}$  to B. We define  $\text{S}_A$  as follows. It waits for  $x^n$  on the ROT interface, and  $\perp$  from OT. Then, it chooses  $d$  uniformly at random and sends it to A on the Comm interface. After receiving  $m^n$  on the Comm interface, it sends the inputs  $x_i := m_i + x'_{i+d}$  for  $i \in \{0, \dots, n-1\}$  to OT.

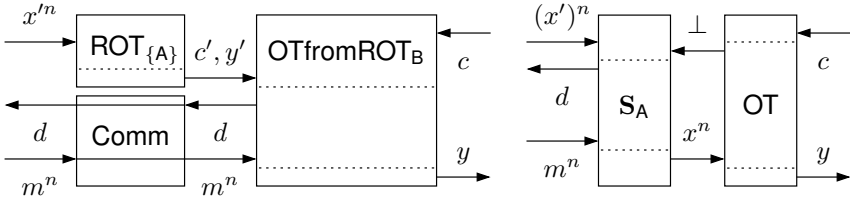

It is easy to verify that  $\text{OTfromROT}_B(\text{ROT}_{\{A\}} \parallel \text{Comm}) \equiv \text{S}_A(\text{OT})$ . □

## 4.2 Oblivious Transfer is Symmetric

Even though  $\binom{2}{1}$ -ROT<sup>1</sup> does not look very symmetric, it is *almost* symmetric, as we will show in this section. In particular, we will show that  $\binom{2}{1}$ -ROT<sup>1</sup> can be *reversed*, using a very simple transformation that we will call ROTOR. Let  $\binom{2}{1}$ -TOR<sup>1</sup> be  $\binom{2}{1}$ -ROT<sup>1</sup> in the opposite direction.

The protocol ROTOR implements  $\binom{2}{1}$ -TOR<sup>1</sup> using  $\binom{2}{1}$ -ROT<sup>1</sup> and is defined as follows.

**Protocol 3. ROTOR<sub>A</sub>:**

1. Receive  $(x'_0, x'_1)$  from ROT.
2. Output  $(c, y)$  to **A**, where  $y = x'_0$  and  $c = x'_0 \oplus x'_1$ .

ROTOR<sub>B</sub>:

1. Receive  $(c', y')$  from ROT.
2. Output  $(x_0, x_1)$ , where  $x_0 = y'$  and  $x_1 = c' \oplus y'$ .

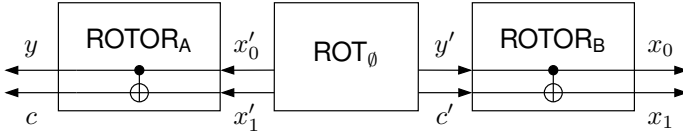

**Lemma 4.3.** *ROTOR( $\binom{2}{1}$ -ROT<sup>1</sup>) securely implements  $\binom{2}{1}$ -TOR<sup>1</sup> in the malicious model.*

*Proof.* From

$$\begin{aligned} x_c &= x_0 \oplus (x_0 \oplus x_1) \cdot c = y' \oplus (y' \oplus c' \oplus y') \cdot (x'_0 \oplus x'_1) \\ &= y' \oplus c' \cdot (x'_0 \oplus x'_1) = y' \oplus x'_{c'} \oplus x'_0 = x'_0 = y \end{aligned}$$

follows that  $\text{TOR}_\emptyset \equiv \text{ROTOR}(\text{ROT}_\emptyset)$ . We choose  $\mathbf{S}_B := \text{ROTOR}_B$  and  $\mathbf{S}_A := \text{ROTOR}_A$ . It is easy to verify that  $\text{ROTOR}_A(\text{ROT}_{\{B\}}) \equiv \mathbf{S}_A(\text{TOR}_{\{B\}})$  and  $\text{ROTOR}_B(\text{ROT}_{\{A\}}) \equiv \mathbf{S}_B(\text{TOR}_{\{A\}})$ .  $\square$

Let  $\binom{2}{1}$ -TO<sup>1</sup> be  $\binom{2}{1}$ -OT<sup>1</sup> in the opposite direction. Using the protocols ROTfromOT, ROTOR and OTfromROT, we can implement  $\binom{2}{1}$ -OT<sup>1</sup> using one instance of  $\binom{2}{1}$ -TO<sup>1</sup>, and get the following theorem.

**Theorem 4.1.**  *$\binom{2}{1}$ -OT<sup>1</sup> can be securely implemented in the malicious model using Comm and one instance of  $\binom{2}{1}$ -TO<sup>1</sup>.*

Protocols that implement  $\binom{2}{1}$ -OT<sup>1</sup> from  $\binom{2}{1}$ -TO<sup>1</sup> have previously been presented in [CS91], and independently in [OVY93]. However, Theorem 4.1 leads to a much simpler and more efficient protocol. The protocol of Theorem 4.1 has been proposed in [WW06], together with an even more efficient protocol, that only used one bit of communication. Unfortunately, that protocol does not work here. The problem is that we are not able to send the value  $\perp$  to A as soon as B has made his choice, if B makes his choice before A has given her input.

### 4.3 In the Semi-Honest Model

In Section 3.3.3 we have seen that security in the malicious model does not always imply security in the semi-honest model. We will therefore show that the protocols ROTfromOT, OTfromROT and ROTOR are also secure in the semi-honest model.

First of all, we have to adjust the definition of ROT. Since a semi-honest adversary will always choose its random inputs truly random, we have  $\text{ROT}_{\{\hat{A}\}} = \text{ROT}_{\{\hat{B}\}} = \text{ROT}_{\emptyset}$ .

**Lemma 4.4.** *Protocol ROTfromOT( $\binom{n}{1}$ -OT<sup>ℓ</sup>) securely implements  $\binom{n}{1}$ -ROT<sup>ℓ</sup> in the semi-honest model.*

*Proof.* Obviously, we have  $\text{ROT}_{\emptyset} \equiv \text{ROTfromOT}(\text{OT})$ .

$(\text{ROTfromOT}_A \parallel \text{ROTfromOT}_B)(\text{OT})$  outputs  $x^n$  to A and  $c$  (on the auxiliary interface) and  $(c, y)$  to B.  $S_B$  receives  $(c, y)$ , outputs  $c$  on the auxiliary interface, and passes  $(c, y)$  along to B. We have

$$(\text{ROTfromOT}_A \parallel \text{ROTfromOT}_B)(\text{OT}) \equiv S_B(\text{ROT}_{\{\hat{B}\}}).$$

$(\text{ROTfromOT}_A \parallel \text{ROTfromOT}_B)(\text{OT})$  outputs  $x^n$  and  $\perp$  (on the auxiliary interface) and  $x^n$  to A, and  $(c, y)$  to B.  $S_A$  receives  $x^n$ , outputs  $x^n$  and  $\perp$  on the auxiliary interface and then passes  $x^n$  along to A. We have

$$(\text{ROTfromOT}_A \parallel \text{ROTfromOT}_B)(\text{OT}) \equiv S_A(\text{ROT}_{\{\hat{A}\}}).$$

Hence, the protocol is secure in the semi-honest model.  $\square$

**Lemma 4.5.**  $OT_{\text{fromROT}}((\binom{n}{1})\text{-ROT}^\ell \parallel \text{Comm})$  securely implements  $(\binom{n}{1})\text{-OT}^\ell$  in the semi-honest model.

*Proof.* We have seen in Lemma 4.2 that  $OT \equiv OT_{\text{fromROT}}(\text{ROT}_\emptyset \parallel \text{Comm})$ .

$(OT_{\text{fromROT}_A} \parallel \underline{OT}_{\text{fromROT}_B})(\text{ROT}_{\{\widehat{B}\}} \parallel \text{Comm})$  chooses  $(c', y')$  uniformly at random, outputs it on the auxiliary interface to **B**, and waits for input  $c$  from **B**. Then it outputs  $d = c' - c$  on the auxiliary interface to **B**, and  $\perp$  to **A**. After receiving  $x^n$  from **A**, it outputs  $m^n$  on the auxiliary interface and  $y = x_c$  on the normal interface to **B**, where  $m_c = y' \oplus y$  and all the other values  $m_i$  are chosen uniformly at random.

$S_B$  chooses  $(c', y')$  uniformly at random and outputs it on the auxiliary interface. It waits for input  $c$ , passes it along to  $OT$ , and outputs  $d := c' - c \pmod{n}$  on the auxiliary interface. After receiving  $y = x_c$  from  $OT$ , it outputs  $m^n$  to **B**, where  $m_c = y' \oplus y$  and the remaining values are chosen uniformly at random. Finally, it outputs  $y$ . It is easy to verify that

$$(OT_{\text{fromROT}_A} \parallel \underline{OT}_{\text{fromROT}_B})(\text{ROT}_{\{\widehat{B}\}} \parallel \text{Comm}) \equiv S_B(OT) .$$

$(\underline{OT}_{\text{fromROT}_A} \parallel OT_{\text{fromROT}_B})(\text{ROT}_{\{\widehat{A}\}} \parallel \text{Comm})$  chooses  $(x')^n$  uniformly at random and outputs it on the auxiliary interface to **A**. After receiving  $c$  from **B**, it chooses  $d$  uniformly at random and outputs  $d$  and  $\perp$  to **A** on the auxiliary interface. After receiving  $x^n$  from **A**, it outputs  $m^n$  to **A**, where  $m_i := x_i \oplus x'_{i+d \pmod{n}}$ , and  $y = x_c$  to **B**.

$S_A$  chooses  $(x')^n$  at random and outputs it on the auxiliary interface to **A**. After receiving  $\perp$  from  $OT$ , it outputs  $d$  chosen uniformly at random on the auxiliary interface and passes  $\perp$  along to **A**. After receiving  $x^n$ , it outputs  $m^n$  to **A**, where  $m_i := x_i \oplus x'_{i+d \pmod{n}}$ , and passes  $x^n$  along to  $OT$ . It is easy to verify that

$$OT_{\text{fromROT}_B}(\text{ROT}_{\{\widehat{A}\}} \parallel \text{Comm}) \equiv S_A(OT) .$$

Hence, the protocol is secure. □

Protocol ROTOR applies a bijective function on the output of ROT. Hence, all the auxiliary output can be simulated from the output of  $(\binom{2}{1})\text{-TOR}^1$ , and we get the following lemma.



**Lemma 4.6.** *ROT $\binom{2}{1}$ -ROT $^1$  securely implements  $\binom{2}{1}$ -TOR $^1$  in the semi-honest model.*

## 4.4 Information-Theoretic Security Conditions

We will now present information-theoretic conditions, which imply that a protocol securely implements ROT either in the malicious or the semi-honest models.

### 4.4.1 In the Malicious Model

The following information-theoretic conditions are similar to the conditions presented in [CSSW06], and to the definitions of randomized oblivious transfer used in [DFSS06] and [Wul07]. However, our correctness condition is stronger, because we require the outputs to be random, if the players are honest.

**Theorem 4.2.** *A protocol  $\mathbf{P}(\mathbf{F}) = (\mathbf{P}_A \parallel \mathbf{P}_B)(\mathbf{F})$  securely implements  $\binom{n}{1}$ -ROT $^\ell$  with an error of at most  $\varepsilon$  in the malicious model, if*

- (Correctness)  $\mathbf{P}(\mathbf{F}_\emptyset) \equiv_\varepsilon \text{ROT}_\emptyset$ .
- (Security for A)  $\mathbf{P}_A(\mathbf{F}_{\{B\}})$  interacts over the interfaces belonging to  $B$  (which produces a transcript  $V$ ), and after the last input is received, it outputs  $X^n \in \{0, 1\}^{\ell \cdot n}$  to  $A$ . There exists a conditional probability distribution  $P_{C|X^n V}$  that produces a random variable  $C \in \{0, \dots, n-1\}$  such that  $(X_0, \dots, X_{C-1}, X_{C+1}, \dots, X_{n-1})$  is  $\varepsilon$ -close to uniform with respect to  $(C, X_C, V)$ .
- (Security for B)  $\mathbf{P}_B(\mathbf{F}_{\{A\}})$  interacts over the interfaces belonging to  $A$  (which produces a transcript  $U$ ), and after the last input is received, it outputs  $(C, Y) \in \{0, \dots, n-1\} \times \{0, 1\}^\ell$  to  $B$  where  $C$  is  $\varepsilon$ -close to uniform with respect to  $U$ .

*Proof.* Let  $\mathbf{P}(\mathbf{F})$  satisfy these conditions. The correctness condition is the same as in Definition 3.2.

Let  $\mathbf{S}_B$  first simulate  $\mathbf{P}_A(\mathbf{F}_{\{B\}})$  which interacts with  $B$  and outputs  $(X')^n$  and the transcript  $V$  of the interaction with  $B$ . Then, it samples  $C$  according to  $P_{C|X^n=(x')^n, V=v}$  and sends  $(C, Y)$  to  $\text{ROT}_{\{B\}}$ , where  $Y := X'_C$ .  $\text{ROT}_{\{B\}}$  will output  $X^n$  to  $A$ , where  $X_C = X'_C$  and

$$(X_0, \dots, X_{C-1}, X_{C+1}, \dots, X_{n-1})$$

is chosen uniformly at random and independent from the rest. Since

$$(X'_0, \dots, X'_{C-1}, X'_{C+1}, \dots, X'_{n-1})$$

is  $\varepsilon$ -close to uniform with respect to  $(C, X_C, V)$ , we have

$$(X^n, C, V) \equiv_{\varepsilon} ((X')^n, C, V),$$

from which follows that

$$\mathbf{S}_B(\text{ROT}_{\{B\}}) \equiv_{\varepsilon} \mathbf{P}_A(\mathbf{F}_{\{B\}}).$$

$\mathbf{S}_A$  is defined as follows. First, it simulates  $\mathbf{P}_B(\mathbf{F}_{\{A\}})$ , which interacts with  $A$  and outputs  $(C', Y')$  and the transcript  $U$  of the interaction with  $A$ . Since  $C'$  is  $\varepsilon$ -close to uniform with respect to  $U$ , we have

$$P_{C'Y'U} = P_{C'U}P_{Y'|UC'} \equiv_{\varepsilon} P_{\overline{C}}P_U P_{Y'|UC'},$$

where  $P_{\overline{C}}$  is the uniform distribution over  $\{0, 1\}$ .  $\mathbf{S}_A$  now calculates  $X'^n$ , where  $X'_i$  is sampled according to the probability distributions  $P_{Y'|U, C'=i}$ , and sends them to  $\text{ROT}_{\{A\}}$ . Note that the behavior of the system  $\mathbf{P}_B(\mathbf{F}_{\{A\}})$  is known, and therefore also the probability distribution  $P_{Y'|U, C'=i}$ .  $B$  receives a value  $C$  chosen uniformly at random, and  $Y = X'_C$  distributed according to  $P_{Y'|U, C'=c}$ . We have

$$P_{CYU} = P_U P_{C|U} P_{Y'|UC'} = P_U P_{\overline{C}} P_{Y'|UC'} \equiv_{\varepsilon} P_{C'Y'U},$$

and, therefore,

$$\mathbf{S}_A(\text{ROT}_{\{A\}}) \equiv_{\varepsilon} \mathbf{P}_B(\mathbf{F}_{\{A\}}).$$

□

Note that the simulation given in Theorem 4.2 is not necessarily efficient.

### 4.4.2 In the Semi-Honest Model

**Theorem 4.3.** *Let  $\varepsilon \geq 0$ . Let  $\mathbf{P}(\mathbf{F}) = (\mathbf{P}_A \parallel \mathbf{P}_B)(\mathbf{F})$  be a protocol that outputs  $X^n$  to  $A$  and  $(C, Y)$  to  $B$ , and let  $U$  be the auxiliary output to  $A$  given by  $\mathbf{P}_A$ , and  $V$  be the auxiliary output to  $B$  given by  $\mathbf{P}_B$ .  $\mathbf{P}(\mathbf{F})$  securely implements  $\binom{n}{1}$ -ROT $^\ell$  with an error of at most  $3\varepsilon$  in the semi-honest model, if*

- (Correctness)  $\mathbf{P}(\mathbf{F}_\emptyset) \equiv_\varepsilon \text{ROT}_\emptyset$ .
- (Security for  $A$ )  $(X_0, \dots, X_{C-1}, X_{C+1}, \dots, X_{n-1})$  is  $\varepsilon$ -close to uniform with respect to  $(C, Y, V)$ .
- (Security for  $B$ )  $C$  is  $\varepsilon$ -close to uniform with respect to  $(X^n, U)$ .

*Proof.* Let  $\mathbf{P}(\mathbf{F})$  satisfy these conditions and let  $P_{\overline{X}^n \overline{CY}}$  be the output distribution of  $\binom{n}{1}$ -ROT $^\ell$ . We have  $P_{X^n CY} \equiv_\varepsilon P_{\overline{X}^n \overline{CY}}$ . Obviously, the correctness condition is satisfied with an error of at most  $\varepsilon$ .

We define  $\mathbf{S}_B$  as follows. After receiving  $(C, Y)$ , it samples a value  $V'$  distributed according to  $P_{V|CY}$  and outputs  $(C, Y, V')$ . We get

$$\begin{aligned}
 P_{X_0 X_1 C Y V} &= P_{X_0 \dots X_{C-1} X_{C+1} \dots X_{n-1} C Y V} P_{X_C | X_0 \dots X_{C-1} X_{C+1} \dots X_{n-1} C Y V} \\
 &\equiv_\varepsilon P_{X_0 \dots X_{C-1} X_{C+1} \dots X_{n-1} C Y V} P_{\overline{X}_C | \overline{CY}} \\
 &\equiv_\varepsilon P_{C Y V} P_{\overline{X}_0 \dots \overline{X}_{C-1} \overline{X}_{C+1} \dots \overline{X}_{n-1}} P_{\overline{X}_C | \overline{CY}} \\
 &= P_{C Y} P_{V|C Y} P_{\overline{X}_0 \dots \overline{X}_{C-1} \overline{X}_{C+1} \dots \overline{X}_{n-1}} P_{\overline{X}_C | \overline{CY}} \\
 &\equiv_\varepsilon P_{\overline{CY}} P_{V|C Y} P_{\overline{X}_0 \dots \overline{X}_{C-1} \overline{X}_{C+1} \dots \overline{X}_{n-1}} P_{\overline{X}_C | \overline{CY}} \\
 &= P_{\overline{X}^n \overline{CY}} P_{V|C Y} = P_{\overline{X}^n \overline{CY}} P_{V'|C Y}
 \end{aligned}$$

and, therefore,

$$(\mathbf{P}_A \parallel \mathbf{P}_B)(\mathbf{F}_{\{\hat{B}\}}) \equiv_{3\varepsilon} \mathbf{S}_B(\text{ROT}_{\{\hat{B}\}}).$$

We define  $\mathbf{S}_A$  as follows. After receiving  $X^n$ , it samples a value  $U'$  distributed according to  $P_{U|X^n}$  and outputs  $(X^n, U')$ . We get

$$\begin{aligned}
 P_{X^n C Y U} &= P_{X^n C U} P_{Y|X^n C U} \equiv_\varepsilon P_{X^n C U} P_{\overline{Y} | \overline{X}^n \overline{C}} \\
 &\equiv_\varepsilon P_{X^n U} P_{\overline{C}} P_{\overline{Y} | \overline{X}^n \overline{C}} = P_{X^n} P_{U|X^n} P_{\overline{C}} P_{\overline{Y} | \overline{X}^n \overline{C}} \\
 &\equiv_\varepsilon P_{\overline{X}^n} P_{\overline{C}} P_{\overline{Y} | \overline{X}^n \overline{C}} P_{U|X^n} = P_{\overline{X}^n \overline{CY}} P_{U'|X^n}
 \end{aligned}$$

and, therefore,

$$(\underline{\mathbf{P}}_A \parallel \mathbf{P}_B)(\mathbf{F}_{\{\hat{A}\}}) \equiv_{3\varepsilon} \mathbf{S}_A(\text{ROT}_{\{\hat{A}\}}).$$

□

One way to sample  $V'$  according to  $P_{V|C,Y}$  is to simulate the protocol  $(\mathbf{P}_A \parallel \underline{\mathbf{P}}_B)(\mathbf{F})$  until  $(V', C', Y')$  is received where  $C' = C$  and  $Y' = Y$ . This simulation needs exponential time in the parameter  $\ell$  and  $n$ , but is efficient if  $\ell$  and  $n$  are small and  $(\mathbf{P}_A \parallel \underline{\mathbf{P}}_B)(\mathbf{F})$  is efficient. Similarly, we can sample  $U'$  by simulating the protocol  $(\underline{\mathbf{P}}_A \parallel \mathbf{P}_B)(\mathbf{F})$  until  $(U', (X')^n)$  is received where  $(X')^n = X^n$ .

## Chapter 5

# Universal Oblivious Transfer

*Universal oblivious transfer* (UOT) is a variant of ROT where the security of the sender is weakened. A malicious receiver is allowed to receive *any* information he wants about the sender's input, as long as he does not receive too much information. A parameter  $\alpha$  specifies a lower bound on the amount of uncertainty the receiver must have over the sender's input, measured in terms of min-entropy. UOT was introduced in [Cac98], together with a protocol that implements ROT from UOT. However, the security proof contained an error which was discovered in [DFSS06]. It was showed that ROT with a string length of  $\ell$  can be implemented from one instance of UOT with an error of at most  $\varepsilon$  if  $\ell \leq \alpha/4 - \frac{3}{4} \log(1/\varepsilon) - 1$ , which is only about half as much as originally claimed in [Cac98].

In Theorem 5.1 we give a new proof for the same protocol that was also used in [Cac98, DFSS06], and show that the protocol is also secure for

$$\ell \leq \alpha/2 - 3 \log(1/\varepsilon)$$

with an error of at most  $2\varepsilon$ . This improves the bound of [DFSS06] by a factor of 2 (at the cost of a larger error term) and achieves the bound that has been originally claimed in [Cac98], which is asymptotically optimal for this protocol.

Our proof makes use of a new *distributed leftover hash lemma* (Lemma 5.3)

which is of independent interest.

## 5.1 Min-Entropy and Randomness Extraction

In this section we show how almost uniform randomness can be extracted out of non-uniform randomness. We use the *min-entropy* to measure the amount of randomness a random variable has.

**Definition 5.1** (Conditional Min-entropy). Let  $X$  and  $Y$  be random variables. The *min-entropy of  $X$  given  $Y$*  is defined as

$$H_{\min}(X | Y) := \min_{xy: P_{XY}(x,y) > 0} \log \frac{1}{P_{X|Y}(x | y)}.$$

We will need the following lemma.

**Lemma 5.1.** For all  $X, Y$ , and  $Z$ , we have  $H_{\min}(X | Z) \geq H_{\min}(X | YZ)$ .

*Proof.* This inequality follows from

$$\begin{aligned} \max_{x,z} P_{X|Z}(x | z) &= \max_{x,z} \sum_y P_Y(y) P_{X|YZ}(x | y, z) \\ &\leq \max_{x,z} \sum_y P_Y(y) \max_{x,y,z} P_{X|YZ}(x | y, z) \\ &= \max_{x,y,z} P_{X|YZ}(x | y, z). \end{aligned}$$

□

We will use *2-universal hash functions* to extract randomness.

**Definition 5.2** ([CW79]). A function  $h : \mathcal{X} \times \mathcal{S} \rightarrow \mathcal{Y}$  is called a *2-universal hash function*, if for all  $x_0 \neq x_1 \in \mathcal{X}$ , we have

$$\Pr[h(x_0, S) = h(x_1, S)] \leq \frac{1}{|\mathcal{Y}|},$$

if  $S$  is uniform over  $\mathcal{S}$ .

The *leftover hash lemma* [ILL89] shows that a 2-universal hash function is able to extract almost all randomness, if some additional uniform randomness  $S$  is provided as a catalyst. Notice that the extracted randomness is independent from  $S$ . A slightly less general form of this lemma has been proved before in [BBR88], where it was called *privacy amplification*. [BBCM95] generalized the notion of privacy amplification to basically the same statement as [ILL89], in a slightly different notion.

**Lemma 5.2** (Leftover hash lemma [BBR88, ILL89]). *Let  $X$  be a random variable over  $\mathcal{X}$  and let  $m > 0$ . Let  $h : \mathcal{S} \times \mathcal{X} \rightarrow \{0, 1\}^m$  be a 2-universal hash function. If*

$$m \leq H_{\min}(X) - 2 \log(1/\varepsilon) ,$$

*then for  $S$  uniform over  $\mathcal{S}$ ,  $h(S, X)$  is  $\varepsilon$ -close to uniform with respect to  $S$ .*

We will now give a distributed version of the leftover hash lemma, where two players independently extract randomness from two dependent random variables  $X$  and  $Y$ . The (normal) leftover hash lemma tells us that if the extracted randomness of  $X$  and  $Y$ , respectively, is smaller than the min-entropy of  $X$  and  $Y$ , respectively, then the extracted strings are close to uniform. However, the two extracted strings might depend on each other. Lemma 5.3 now states that if the total length of the extracted randomness is smaller than the min-entropy of  $(X, Y)$ , then the two strings are also almost independent. Clearly, this bound is optimal.

**Lemma 5.3** (Distributed leftover hash lemma). *Let  $X$  and  $Y$  be random variables over  $\mathcal{X}$  and  $\mathcal{Y}$ , and let  $m, n > 0$ . Let  $g : \mathcal{S} \times \mathcal{X} \rightarrow \{0, 1\}^m$  and  $h : \mathcal{R} \times \mathcal{Y} \rightarrow \{0, 1\}^n$  be 2-universal hash functions. If*

$$\begin{aligned} m &\leq H_{\min}(X) - 2 \log(1/\varepsilon) , \\ n &\leq H_{\min}(Y) - 2 \log(1/\varepsilon) , \quad \text{and} \\ m + n &\leq H_{\min}(XY) - 2 \log(1/\varepsilon) , \end{aligned}$$

*then, for  $(S, R)$  uniform over  $\mathcal{S} \times \mathcal{R}$ ,  $(g(S, X), h(R, Y))$  is  $\varepsilon$ -close to uniform with respect to  $(S, R)$ .*

*Proof.* For any  $W$  having distribution  $P_W$  over  $\mathcal{W}$ , and  $W'$  uniformly dis-

tributed over  $\mathcal{W}$ , we have

$$\begin{aligned} \Delta(W, W') &= \frac{1}{2} \sum_w \left| P_W(w) - \frac{1}{|\mathcal{W}|} \right| = \frac{1}{2} \sqrt{\left( \sum_w \left| P_W(w) - \frac{1}{|\mathcal{W}|} \right| \right)^2} \\ &\leq \frac{1}{2} \sqrt{|\mathcal{W}|} \sqrt{\sum_w \left( P_W(w) - \frac{1}{|\mathcal{W}|} \right)^2} \\ &= \frac{1}{2} \sqrt{|\mathcal{W}|} \sqrt{\sum_w P_W^2(w) - \frac{1}{|\mathcal{W}|}}. \end{aligned}$$

Here we used Lemma A.3.

Let  $V = g(S, X)$ ,  $V' = h(R, Y)$  and  $U, U'$  be two uniform random variables over  $\{0, 1\}^m$  and  $\{0, 1\}^n$ . Choosing  $W := (V, V', S, R)$  and  $W' := (U, U', S, R)$  in the above inequality, we get

$$\begin{aligned} &\Delta((V, V', S, R), (U, U', S, R)) \\ &\leq \frac{1}{2} \sqrt{|\mathcal{S}||\mathcal{R}|2^{m+n}} \sqrt{\sum_{vv'sr} P_{VV'SR}^2(v, v', s, r) - \frac{1}{|\mathcal{S}||\mathcal{R}|2^{m+n}}}. \end{aligned}$$

Since  $\sum_x P_X^2(x)$  is the *collision probability*<sup>1</sup> of a random variable  $X$ , we have for  $(X_0, Y_0)$  and  $(X_1, Y_1)$  independently distributed according to  $P_{XY}$  and for uniformly random  $S_0, S_1, R_0$ , and  $R_1$  that

$$\begin{aligned} \sum_{vv'sr} P_{VV'SR}^2(v, v', s, r) &= \Pr[S_0 = S_1 \wedge R_0 = R_1] \\ &\cdot \Pr[g(X_0, S_0) = g(X_1, S_0) \wedge h(Y_0, R_0) = h(Y_1, R_0)]. \end{aligned}$$

Because  $g$  and  $h$  are 2-universal hash functions, we have

$$\begin{aligned} &\Pr[g(X_0, S_0) = g(X_1, S_0) \wedge h(Y_0, R_0) = h(Y_1, R_0)] \\ &\leq \Pr[X_0 = X_1 \wedge Y_0 = Y_1] + 2^{-m} \Pr[X_0 \neq X_1 \wedge Y_0 = Y_1] \\ &\quad + 2^{-n} \Pr[X_0 = X_1 \wedge Y_0 \neq Y_1] + 2^{-m-n} \\ &\leq 2^{-m-n} \cdot \varepsilon^2 + 2^{-m} 2^{-n} \cdot \varepsilon^2 + 2^{-n} 2^{-m} \cdot \varepsilon^2 + 2^{-m-n} \\ &= (1 + 3\varepsilon^2) 2^{-m-n}, \end{aligned}$$

<sup>1</sup> Let  $X_0$  and  $X_1$  be distributed according to  $P_X$ . The *collision probability* is  $\Pr[X_0 = X_1] = \sum P_X(x)^2$ .



which implies that

$$\begin{aligned} & \Delta((V, V', S, R), (U, U', S, R)) \\ & \leq \frac{1}{2} \sqrt{|\mathcal{S}||\mathcal{R}|2^{m+n}} \sqrt{\frac{1}{|\mathcal{S}||\mathcal{R}|} \frac{1+3\varepsilon^2}{2^{m+n}} - \frac{1}{|\mathcal{S}||\mathcal{R}|2^{m+n}}} \leq \frac{\sqrt{3}}{2} \varepsilon. \end{aligned}$$

□

Notice that Lemma 5.3 implies Lemma 5.2.

## 5.2 Definition of Universal Oblivious Transfer

We now define *universal oblivious transfer*, or  $(\alpha)$ - $\binom{2}{1}$ -UOT $^n$ , which is a variant of  $\binom{2}{1}$ -ROT $^n$  that provides weaker security for **A**. For  $\mathcal{A} = \emptyset$  or  $\mathcal{A} = \{\mathbf{A}\}$ , UOT is equal to ROT. But for  $\mathcal{A} = \{\mathbf{B}\}$ , instead of requiring that **B** does not know anything about one of the two strings, we only require that he does not entirely know both of them, i.e., the a min-entropy of sender's input is at least  $\alpha$ . Note that from Lemma 2 in [RW05], it follows that there is no need to use different kinds of Rényi-entropies [Rén61] as done in [Cac98] or [DFSS06], as they are basically all equivalent to the min-entropy.

**Definition 5.3** (Universal oblivious transfer). The system  $(\alpha)$ - $\binom{2}{1}$ -UOT $^n$  (or, if  $\alpha$  and  $n$  are clear from the context, UOT) is defined as a collection of systems

$$\text{UOT} = (\text{UOT}_{\emptyset}, \text{UOT}_{\{\mathbf{A}\}}, \text{UOT}_{\{\mathbf{B}\}}),$$

where  $\text{UOT}_{\emptyset} = \binom{2}{1}$ -ROT $^n_{\emptyset}$  and  $\text{UOT}_{\{\mathbf{A}\}} = \binom{2}{1}$ -ROT $^n_{\{\mathbf{A}\}}$ .  $\text{UOT}_{\{\mathbf{B}\}}$  is defined as follows. The system waits for **B** to input a distribution

$$p \in \{P_{X_0 X_1} \mid H_{\min}(X_0, X_1) \geq \alpha\},$$

where  $(X_0, X_1) \in \{0, 1\}^n \times \{0, 1\}^n$ . After receiving  $p$ , it chooses  $(x_0, x_1)$  according to  $p$  and outputs  $(x_0, x_1)$  to **A**.

Notice that our definition UOT is slightly weaker than the definitions used in [Cac98, DFSS06]. Because our UOT is a weak version of ROT,

we do not only allow the malicious receiver to receive arbitrary information about his input, but we also allow him to freely choose his output. For example, we allow him to select  $2n - \alpha$  bit and freely fix their values. UOT will then choose the remaining  $\alpha$  bit randomly.

### 5.3 Universal Oblivious Transfer Amplification

Our protocol ROTfromUOT is basically the same as the protocols used in [BC97, Cac98, BCW03, DFSS06]. It securely implements  $\binom{1}{2}$ -ROT $^\ell$  using one instance of  $(\alpha)$ - $\binom{2}{1}$ -UOT $^n$  and Comm in the malicious model. Let  $h : \{0, 1\}^n \times \mathcal{R} \rightarrow \{0, 1\}^\ell$  be a 2-universal hash function. The protocol is defined as follows.

**Protocol 4.** ROTfromUOT<sub>A</sub>:

1. Receive  $(x_0, x_1) \in \{0, 1\}^n \times \{0, 1\}^n$  from UOT.
2. Choose  $(r_0, r_1) \in \mathcal{R}^2$  uniformly at random.
3. Send  $(r_0, r_1)$  to Comm.
4. Output  $(u_0, u_1) \in \{0, 1\}^\ell \times \{0, 1\}^\ell$  to **A**, where  $u_0 := h(x_0, r_0)$  and  $u_1 := h(x_1, r_1)$ .

ROTfromUOT<sub>B</sub>:

1. Receive  $(c, w) \in \{0, 1\} \times \{0, 1\}^n$  from UOT and  $(r_0, r_1) \in \mathcal{R}^2$  from Comm.
2. Output  $(c, y) \in \{0, 1\} \times \{0, 1\}^\ell$  to **B**, where  $y := h(r_c, w)$ .

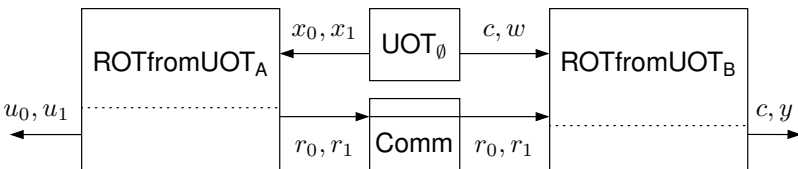

We will now show that this protocol indeed achieves the optimal bound of  $\ell \approx \alpha/2$ . The proof works roughly as follows. We define an additional random variable  $A \in \{0, 1, 2\}$  that distinguishes between three different cases, and show that in each case there exists a random variable  $C$  such that  $U_{1-C}$  is almost uniform and independent of the rest. If  $A \in \{0, 1\}$ , we can lower-bound the min-entropy of  $X_{1-A}$  conditioned on  $X_A$ , and are therefore able to apply Lemma 5.2 for  $C = A$ . If  $A = 2$  we have lower bounds for the min-entropy of  $X_0$ ,  $X_1$ , and  $(X_0, X_1)$ , which allow us to apply Lemma 5.3. We need that  $\Pr[A = 2] \geq \varepsilon$ . If this is not the case, we ignore the events  $A = 2$  at the cost of an additional error of at most  $\varepsilon$ .

**Theorem 5.1.** *Let  $\alpha, n, \ell, \varepsilon > 0$ . Protocol  $\text{ROTfromUOT}((\alpha)\text{-}\binom{2}{1}\text{-UOT}^n)$  securely implements  $\binom{2}{1}\text{-ROT}^\ell$  in the malicious model with an error of at most  $2\varepsilon$ , if  $\ell \leq \alpha/2 - 3 \log(1/\varepsilon)$ .*

*Proof.* Obviously, for  $\mathcal{A} = \emptyset$ , we have  $\text{ROTfromUOT}(\text{UOT}_{\{\emptyset\}}) \equiv \text{ROT}_{\{\emptyset\}}$ .

Let  $\mathcal{A} = \{\mathbf{A}\}$ .  $\text{ROTfromUOT}_{\mathbf{B}}(\text{UOT}_{\{\mathbf{A}\}})$  waits for receiving  $(x_0, x_1)$  and  $(r_0, r_1)$  from  $\mathbf{A}$  and then outputs  $(c, y)$  to  $\mathbf{B}$ , where  $c$  is chosen uniformly at random and  $y = h(x_c, r_c)$ . We define  $\mathbf{S}_{\mathbf{A}}$  as follows. It waits for receiving  $(x_0, x_1)$  and  $(r_0, r_1)$  from  $\mathbf{A}$  and sends  $(h(x_0, r_0), h(x_1, r_1))$  to  $\text{ROT}$ . It is easy to see that  $\text{ROTfromUOT}_{\mathbf{B}}(\text{UOT}_{\{\mathbf{A}\}}) = \mathbf{S}_{\mathbf{A}}(\text{ROT})$ .

Let  $\mathcal{A} = \{\mathbf{B}\}$ . The system  $\text{ROTfromUOT}_{\mathbf{A}}(\text{UOT}_{\{\mathbf{B}\}})$  receives the value  $p$  from  $\mathbf{B}$ , and then outputs  $(U_0, U_1)$  to  $\mathbf{A}$  and  $(R_0, R_1)$  to  $\mathbf{B}$ . In the following, we will implicitly condition on the values  $P = p$ . Let

$$S_i := \left\{ x_i \in \mathcal{X}_i : \Pr[X_i = x_i] \leq 2^{-\alpha/2} \right\},$$

for  $i \in \{0, 1\}$ . Let

$$g(x_0, x_1) := \begin{cases} 2 & \text{if } (x_0 \in S_0) \wedge (x_1 \in S_1) \\ 0 & \text{if } (x_0 \notin S_0) \wedge (x_1 \in S_1) \\ 1 & \text{if } (x_0 \in S_0) \wedge (x_1 \notin S_1) \\ u & \text{if } (x_0 \notin S_0) \wedge (x_1 \notin S_1), \end{cases} \quad (5.1)$$

and  $A := g(X_0, X_1)$ , for  $u$  chosen uniformly at random from  $\{0, 1\}$ . If  $\Pr[A = 2] < \varepsilon$ , let  $\mathcal{E}$  be the event that  $A < 2$ , and let  $\mathcal{E}$  be the event with probability 1 otherwise. We have  $\Pr[\mathcal{E}] \geq 1 - \varepsilon$ , and the event  $(A = 2) \cap \mathcal{E}$  either has probability 0 or at least  $\varepsilon$ . Let  $C = \min(A, 1)$ .

- For  $A = a \in \{0, 1\}$  and  $\Pr[A = a \wedge \mathcal{E}] > 0$ , we have  $C = a$ . All  $x_a \in S_a$  have  $\Pr[X_a = x_a \mid A = a \wedge \mathcal{E}] = 0$ . For all  $x_a \notin S_a$  we have

$$\begin{aligned} & \Pr[X_a = x_a \wedge A = a \wedge \mathcal{E}] \\ &= \Pr[X_a = x_a \wedge X_{1-a} \in S_{1-a}] + \frac{\Pr[X_a = x_a \wedge X_{1-a} \notin S_{1-a}]}{2} \\ &\geq \frac{\Pr[X_a = x_a]}{2} \geq 2^{-\alpha/2-1}. \end{aligned}$$

It follows that

$$\begin{aligned} & \Pr[X_{1-a} = x_{1-a} \mid X_a = x_a \wedge A = a \wedge \mathcal{E}] \\ &= \frac{\Pr[X_{1-a} = x_{1-a} \wedge X_a = x_a \wedge A = a \wedge \mathcal{E}]}{\Pr[X_a = x_a \wedge A = a \wedge \mathcal{E}]} \\ &\leq 2^{-\alpha} / 2^{-\alpha/2-1} = 2^{-\alpha/2+1}, \end{aligned}$$

and hence,  $H_{\min}(X_{1-C} \mid X_C, A = a, \mathcal{E}) \geq \alpha/2 - 1$ . Since  $R_0$  and  $R_1$  are uniformly distributed and independent of the rest, it follows from Lemma 5.2 that, conditioned on  $(A = a) \cap \mathcal{E}$ ,  $U_{1-C}$  is  $\varepsilon$ -close to uniform with respect to  $(R_0, R_1, U_C)$ .

- If  $A = 2$  and  $\Pr[A = 2 \wedge \mathcal{E}] > 0$ , then  $C = 1$ ,  $\Pr[A = 2 \wedge \mathcal{E}] \geq \varepsilon$ ,  $\Pr[X_0 = x_0 \wedge X_1 = x_1 \mid A = 2 \wedge \mathcal{E}] \leq 2^{-\alpha}/\varepsilon$ , and  $\Pr[X_i = x_i \mid A = 2 \wedge \mathcal{E}] \leq 2^{-\alpha/2}/\varepsilon$ , for  $i \in \{0, 1\}$ . It follows that

$$\begin{aligned} H_{\min}(X_0 \mid A = 2 \wedge \mathcal{E}) &\geq \alpha/2 - \log(1/\varepsilon) \\ H_{\min}(X_1 \mid A = 2 \wedge \mathcal{E}) &\geq \alpha/2 - \log(1/\varepsilon) \\ H_{\min}(X_0 X_1 \mid A = 2 \wedge \mathcal{E}) &\geq \alpha - \log(1/\varepsilon). \end{aligned}$$

Since  $R_0$  and  $R_1$  are uniformly distributed and independent of the rest, it follows from Lemma 5.3 that conditioned on  $(A = 2) \cap \mathcal{E}$ ,  $(U_0, U_1)$  is  $\varepsilon$ -close to uniform with respect to  $(R_0, R_1)$ , from which follows that  $U_{1-C}$  is  $\varepsilon$ -close to uniform with respect to  $(R_0, R_1, U_C)$ .

Therefore, for all  $a \in \{0, 1, 2\}$ , conditioned on  $(A = a) \cap \mathcal{E}$ , the distribution of  $U_{1-C}$  is  $\varepsilon$ -close to uniform with respect to  $(R_0, R_1, C, U_C)$ . Since  $\Pr[\mathcal{E}] \geq 1 - \varepsilon$ , it follows from Lemma 2.5 that  $U_{1-C}$  is  $2\varepsilon$ -close to uniform with respect to  $(R_0, R_1, C, U_C)$ . Because this holds for every  $P = p$ , it follows that  $U_{1-C}$  is  $2\varepsilon$ -close to uniform with respect to  $(C, U_C, P, R_0, R_1)$ .

We define  $\mathbf{S}_B$  as follows. After receiving  $p : \mathcal{X}_0 \times \mathcal{X}_1 \rightarrow [0, 1]$  from  $B$ , it simulates  $\text{UOT}_{\{B\}}$  on input  $p$ , from which it gets the values  $X'_0$  and  $X'_1$ ,

distributed according to  $p$ . It calculates  $C' = \min(g(X'_0, X'_1), 1)$  according to (5.1). Then it choses  $R'_0$  and  $R'_1$  uniformly at random from  $\mathcal{R}$ , sends  $(C', h(X'_{C'}, R'_{C'}))$  to  $\text{ROT}_{\{B\}}$  and outputs  $(R'_0, R'_1)$  on the  $\text{Comm}$  interface.  $\text{ROT}_{\{B\}}$  will output  $(U'_0, U'_1)$  to  $A$ , where  $U'_C = h(X'_{C'}, R'_{C'})$  and  $U'_{1-C}$  is chosen uniformly at random and independent from the rest. Since  $U_{1-C}$  is  $2\varepsilon$ -close to uniform with respect to  $(C, P, U_C, R_0, R_1)$ , it is easy to see that

$$(U'_0, U'_1, C', P, R'_0, R'_1) \equiv_{2\varepsilon} (U_0, U_1, C, P, R_0, R_1),$$

from which follows that

$$\text{ROTfromUOT}_A(\text{UOT}_{\{B\}}) \equiv_{2\varepsilon} \mathbf{S}_B(\text{ROT}_{\{B\}}).$$

□

## 5.4 Applications

The definition of UOT emerged as a generalization of the protocol presented in [BC97, BCW03] to implement string OT out of bit OT. Therefore it is not surprising that the reduction we presented in this chapter can be used to implement string OT from bit OT. Asymptotically, our protocol also achieves the same bound as the protocol of [BC97, BCW03] for this task. Our protocol can also be used to implement OT from GOT, which leads to better bounds than the ones presented in [BC97, BCW03] or [DFSS06].

Recently, another very interesting application of UOT has been presented: in [DFR<sup>+</sup>06], it was shown that in the *bounded quantum-storage model*, it is possible to implement a simple protocol that achieves a quantum version of UOT. Whereas it is not clear how the results of [DFSS06] can be used in that setting to implement OT, they showed that a simplified version of our proof (only requiring the normal leftover hash lemma) can directly be applied, using a quantum version of the leftover hash lemma, called *privacy amplification against quantum adversaries* [RK05, Ren05]. It is also possible to generalize our distributed leftover hash lemma to the quantum setting, and therefore the proof we present in this chapter can also be used in the setting of [DFR<sup>+</sup>06] to improve the efficiency of their reduction.



## Chapter 6

# Weak Oblivious Transfer

*Weak oblivious transfer* (WOT), introduced in [DKS99], is a weak variant of ROT where *both* players may obtain additional information about the other player's input, and where the output may have some errors. In [DKS99] it was used as a tool to construct OT from *unfair primitives*, i.e., primitives where the adversary is more powerful than the honest participants, such as the *unfair noisy channel*. WOT is parameterized by three parameters,  $p$ ,  $q$ , and  $\varepsilon$ , where  $p$  measures the amount of side information that the sender gets about the receiver's choice bit,  $q$  the amount of side information the receiver gets about the sender's second input bit, and  $\varepsilon$  is the maximal probability that an error occurs.

While the definition of WOT is very informal in [DKS99], the definition used in [DFMS04] (which gives an ideal functionality of WOT) made implicitly a quite strong assumption, namely that the event that an adversary gains information is independent of the error. Unfortunately, the protocol used in [DKS99, DFMS04] based on unfair noisy channels does not achieve these strong requirements. We propose two new, weaker definitions of WOT, one for the semi-honest (Definition 6.1) and one for the malicious model (Definition 6.2), that do not have these assumptions. Also, our definitions make the use of *generalized weak oblivious transfer* [DFMS04], at least for the protocols we have at the moment, unnecessary.

In Theorem 6.1 we restate the impossibility result from [DKS99] that there does not exist a protocol which implements OT from WOT if  $p+q+2\varepsilon \geq 1$ .

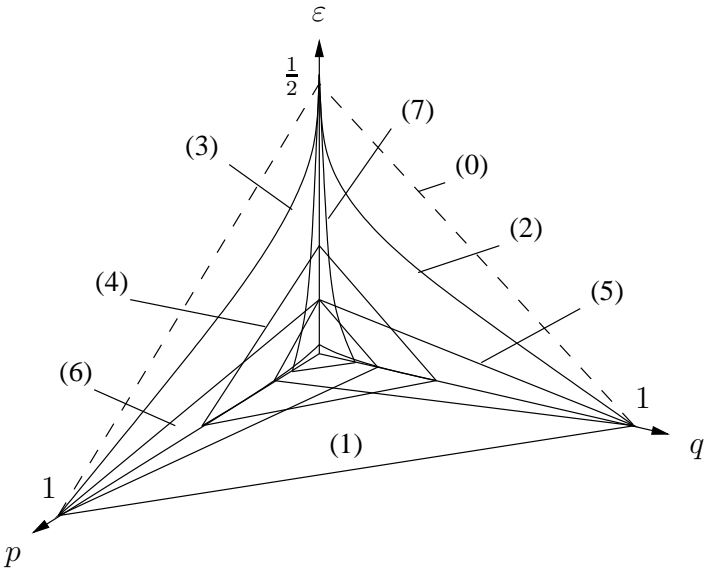

**Figure 6.1:** The bounds on the parameters  $p$ ,  $q$ , and  $\varepsilon$  for WOT. (0): Impossibility, Theorem 6.1. (1): Special case where  $\varepsilon = 0$  or  $\varepsilon$  is small, Theorem 6.2 and Corollary 6.2. (2-3): Special cases where  $p = 0$  or  $q = 0$ , Theorem 6.3 and Corollary 6.1. (4-7): General case where  $p, q, \varepsilon > 0$ , Theorem 6.4.



Then, we give several protocols that implement ROT from WOT. In Theorem 6.2, we show that the bound of  $p + q < 1$  and  $\varepsilon = 0$  presented in [DKS99] can also be achieved using our definition, both in the semi-honest and the malicious model. Furthermore, we give a more detailed analysis of the protocols's efficiency. For the case where  $\varepsilon > 0$ , our new definition makes it necessary to use a different protocol to reduce the error  $\varepsilon$ , which implies that we are not able to achieve the same bound as [DKS99]. In Theorems 6.3 and Corollary 6.1, we show that for the special case where either  $p = 0$  or  $q = 0$  holds, ROT can securely be implemented from WOT in the semi-honest model if

$$(p = 0 \wedge \sqrt{q} + 2\varepsilon < 1) \quad \vee \quad (q = 0 \wedge \sqrt{p} + 2\varepsilon < 1) .$$

We achieve these bounds very easily by using an interesting connection to key agreement protocols [HR05, Hol06] and the statistical distance polarization problem [SV99, Vad99]. For the general case where  $p$ ,  $q$ , and  $\varepsilon$  may be larger than 0, we show in Theorem 6.4 that if

$$p + q + 2\varepsilon \leq 0.24$$

or

$$(p + 22q + 44\varepsilon < 1) \quad \vee \quad (22p + q + 44\varepsilon < 1) \quad \vee \quad (7\sqrt{p+q} + 2\varepsilon < 1) ,$$

ROT can efficiently be implemented from WOT secure in the semi-honest model. These bounds do not achieve the bound of  $p + q + 2\varepsilon < 0.45$  from [DKS99] for all values  $p$ ,  $q$ , and  $\varepsilon$ , but they are better for the cases where two parameters are small and one is large. Finally, we show in Corollary 6.2 that we can also implement ROT from WOT in the semi-honest model if

$$(1 - p - q)^4 < -178 \cdot \log(1 - 2\varepsilon) ,$$

which means that if  $\varepsilon$  is small enough, then we can achieve OT for all values  $p + q < 1$ .

## 6.1 Definition of WOT

In this section we give formal definitions of WOT. Because our protocols will reduce the information of the adversary by using the XOR of several

values, the maximum bit-prediction advantage ( $\text{PredAdv}$ ) turns out to be a good measure for the adversary's side information. Furthermore, it has the advantage that we can easily find a computational version of this measure, which will be very useful in Chapter 7. Our definition of WOT is inspired by the definition of *weak bit agreement* in [Hol05, Hol06].

### 6.1.1 In the Semi-Honest Model

We start with the definition of WOT in the semi-honest model. Since the adversary is not able to choose which information he would like to obtain in the semi-honest model, he may only obtain whatever information the functionality provides him with. But we do not want to fix this information, as we want to cover a wide range of possibilities — we might not even know what information the functionality will provide to the adversary. Therefore, we cannot define an ideal functionality. Instead, we will define a set of ideal functionalities, and assume that one instance of this set is provided to us, but we may not know which instance. We will define this set of ideal functionalities by a list of properties that the ideal functionality must satisfy.

**Definition 6.1** (Weak oblivious transfer, semi-honest model). Let

$$\mathbf{F} = (\mathbf{F}_\emptyset, \mathbf{F}_{\{\hat{A}\}}, \mathbf{F}_{\{\hat{B}\}})$$

be a collection of systems in the semi-honest model. Let  $\mathbf{F}$  output  $(X_0, X_1)$  to  $\mathbf{A}$  and  $(C, Y)$  to  $\mathbf{B}$ . Let  $U$  be the auxiliary output to  $\mathbf{A}$  by  $\mathbf{F}_{\{\hat{A}\}}$  and  $V$  be the auxiliary output to  $\mathbf{B}$  by  $\mathbf{F}_{\{\hat{B}\}}$ . Let  $E := X_C \oplus Y$ .  $\mathbf{F}$  implements  $(p, q, \varepsilon)$ -WOT in the semi-honest model, if

- (Correctness)  $\Pr[E = 1] \leq \varepsilon$ .
- (Security for  $\mathbf{A}$ )  $\text{PredAdv}(X_{1-C} \mid V, E) \leq q$ .
- (Security for  $\mathbf{B}$ )  $\text{PredAdv}(C \mid U, E) \leq p$ .

We also use  $(p, q)$ -WOT for  $(p, q, 0)$ -WOT.

It is not immediately clear why we require that  $X_{1-C}$  and  $C$  are difficult to guess even when additionally the value  $E$  is given. We do this

for allowing the adversary to learn the error during the protocol without getting additional information about  $X_{1-C}$  or  $C$ . For example, in the protocol E-Reduce, **B** may get to know  $X_C$  during the protocol, which means that he gets to know  $E = Y \oplus X_C$ . Therefore, we must make sure that his side information about  $X_{1-C}$  is not increased if he gets to know  $E$ . Note, however, that for the protocols we present here, it would be sufficient to only require  $\text{PredAdv}(C | U) \leq p$  for the security for **B**, because  $E$  is never leaked to **A**. We do not use this definition in order to keep WOT symmetric, and to get a stronger Theorem 7.2 that is simpler to prove. (Otherwise, Theorem 7.2 would not work for all protocols, but just for the protocols we present here.)

We will now show that the conditions of WOT suffice to implement ROT in the semi-honest model. We need the following lemma.

**Lemma 6.1.** *Let  $P_U$  be the uniform distribution over  $\{0, 1\}$  and let  $P_{CX_0X_1}$  be a distribution over  $\{0, 1\}^3$  for which  $P_{CX_1X_0} \equiv_\varepsilon P_U P_{X_1X_0}$  and  $P_{X_{1-C}X_C} \equiv_\varepsilon P_U P_{X_C}$  holds. Then  $\Delta(P_{CX_0X_1}, P_U P_U P_U) \leq 4\varepsilon$ .*

*Proof.* Let  $a := P_{CX_1X_0}(0, 0, 0)$ ,  $b := P_{CX_1X_0}(0, 0, 1)$ ,  $c := P_{CX_1X_0}(0, 1, 0)$ ,  $d := P_{CX_1X_0}(0, 1, 1)$ ,  $\dots$ , and let  $h := P_{CX_1X_0}(1, 1, 1)$ . From  $P_{CX_1X_0} \equiv_\varepsilon P_U P_{X_1X_0}$  and Lemma A.6, we get

$$|a - e| + |b - f| + |c - g| + |d - h| \leq 2\varepsilon,$$

and from  $P_{X_{1-C}X_C} \equiv_\varepsilon P_U P_{X_C}$  and Lemma A.6

$$|a - c| + |b - d| + |e - f| + |g - h| \leq 2\varepsilon.$$

Adding up the two inequalities, we get

$$\begin{aligned} |e - a| + |a - c| + |c - g| + |g - h| \\ + |h - d| + |d - b| + |b - f| + |f - e| \leq 4\varepsilon. \end{aligned} \quad (6.1)$$

It is easy to see that the difference between the minimal and the maximal values in the set  $\{a, \dots, h\}$  is at most  $2\varepsilon$ , and that the statistical distance is maximized for (6.1) by distributions where  $n \in \{1, \dots, 7\}$  values have equal probability  $1/8 + 2\varepsilon - \varepsilon n/4$ , and  $8 - n$  values have equal probability  $1/8 - \varepsilon n/4$ . The statistical distance is  $\varepsilon n(2 - n/4)$ , which is maximized for  $n = 4^1$ , where it is  $4\varepsilon$ .  $\square$

<sup>1</sup>Note that such a distribution does not satisfy our original, stricter requirements. Values that do satisfy them are  $a = e = f = 1/2 + 5/4 \cdot \varepsilon$  and  $b = d = h = g = c = 1/2 - 3/4 \cdot \varepsilon$ , which gives a statistical distance of 3.75.

**Lemma 6.2.** *If a protocol  $\mathbf{F}$  implements  $(\varepsilon, \varepsilon, \varepsilon)$ -WOT, then it implements  $(\binom{2}{1}$ )-ROT<sup>1</sup> secure in the semi-honest model, with an error of at most  $9\varepsilon$ .*

*Proof.* Let  $(X_0, X_1, C, Y)$  be the output of  $\mathbf{F}_\emptyset$ , let  $U$  be the auxiliary output of  $\mathbf{F}_{\{A\}}$  to **A** and  $V$  the auxiliary output of  $\mathbf{F}_{\{B\}}$  to **B**. From Lemma 2.6 follows that  $C$  is  $\varepsilon/2$ -close to uniform with respect to  $(E, X_0, X_1, U)$ , and that  $X_{1-C}$  is  $\varepsilon/2$ -close to uniform with respect to  $(E, C, Y, V)$ . Let  $P_{\overline{X_0 X_1 C Y}}$  be the output distribution of ROT <sub>$\emptyset$</sub> .

Lemma 6.1 implies that  $P_{X_0 X_1 C} \equiv_{2\varepsilon} P_{\overline{X_0 X_1 C}}$ . Since  $\Pr[Y \neq X_C] \leq \varepsilon$ , we have

$$P_{X_0 X_1 C Y} \equiv_\varepsilon P_{X_0 X_1 C} P_{Y|\overline{X_0 X_1 C}} \equiv_{2\varepsilon} P_{\overline{X_0 X_1 C Y}}.$$

We can now apply Theorem 4.3. □

## 6.1.2 In the Malicious Model

We will now also give a formal definition of WOT in the malicious model. The definition differs from the semi-honest case in two important points. Firstly, since we do not have any protocol that can do error reduction in the malicious model, we will only define the case without any error, i.e.,  $\varepsilon = 0$ . Secondly, for the security of **A**, we require that the XOR of the two input bits is difficult to guess, because this is a much easier requirement than the standard approach used in Theorem 4.2. Lemma 6.3 shows that the two conditions are equivalent. Notice that the security of the XOR does not suffice in the semi-honest model, and, therefore, this trick cannot be applied there. On the other hand, since in the malicious model a corrupted **B** may choose  $C$  freely, we cannot use Lemma 6.1, and, therefore, the condition  $\Pr[Y \neq X_C] = 0$  would not suffice in the malicious model.

**Definition 6.2** (Weak oblivious transfer, malicious model). Let

$$\mathbf{F} = (\mathbf{F}_\emptyset, \mathbf{F}_{\{A\}}, \mathbf{F}_{\{B\}})$$

be a collection of systems in the malicious model. The system  $\mathbf{F}$  implements  $(p, q)$ -WOT (or, if  $p$  and  $q$  are clear from the context, WOT) in the malicious model, if

- (Correctness):  $\mathbf{F}_\emptyset \equiv \text{ROT}$ .

- (Security for A): The system  $\mathbf{F}_{\{B\}}$  interacts over the interfaces belonging to B (which produces a transcript  $V$ ), and after the last input is received over these interfaces, it outputs  $(X_0, X_1) \in \{0, 1\}^2$  to A where  $\text{PredAdv}(X_0 \oplus X_1 \mid V) \leq q$ .
- (Security for B) The system  $\mathbf{F}_{\{A\}}$  interacts over the interfaces belonging to A (which produces a transcript  $U$ ), and after the last input is received over these interfaces, it outputs  $(C, Y) \in \{0, 1\}^2$  to B where  $\text{PredAdv}(C \mid U) \leq p$ .

Notice that since we are now in the malicious model, the adversary is able to choose what information he would like to receive, and we could define an ideal functionality in a similar way as we did in Definition 5.3 for UOT. We did not do this in order to be closer to Definition 6.1 and Theorem 4.2.

Again, we will first show that WOT suffices to implement ROT in the malicious model. We will need the following lemma, which has already been proved in [DFSS06].

**Lemma 6.3.** *Let  $P_{X_0 X_1}$  be given. There exists a random variable  $C$  distributed according to a conditional distribution  $P_{C \mid X_0, X_1}$  such that  $X_{1-C}$  is uniform with respect to  $(C, X_C)$ , if and only if  $X_0 \oplus X_1$  is uniformly distributed.*

*Proof.* Let  $P_{X_0 X_1 C}$  be a distribution such that  $X_{1-C}$  is uniform with respect to  $(C, X_C)$ . We have

$$\begin{aligned}
 \Pr[X_0 \oplus X_1 = 0] &= P_{X_0 X_1 C}(0, 0, 0) + P_{X_0 X_1 C}(1, 1, 0) \\
 &\quad + P_{X_0 X_1 C}(0, 0, 1) + P_{X_0 X_1 C}(1, 1, 1) \\
 &= P_{X_0 X_1 C}(0, 1, 0) + P_{X_0 X_1 C}(1, 0, 0) \\
 &\quad + P_{X_0 X_1 C}(1, 0, 1) + P_{X_0 X_1 C}(0, 1, 1) \\
 &= \Pr[X_0 \oplus X_1 = 1].
 \end{aligned}$$

Hence,  $X_0 \oplus X_1$  is uniformly distributed.

The other direction is slightly more complicated. Let  $X_0 \oplus X_1$  be uniformly distributed. We choose

$$P_{C \mid X_0, X_1}(0 \mid x_0, x_1) := \frac{\min(P_{X_0 X_1}(x_0, 0), P_{X_0 X_1}(x_0, 1))}{P_{X_0 X_1}(x_0, x_1)}.$$

For  $C = 0$  and  $x_0 \in \{0, 1\}$ , we have

$$\begin{aligned} P_{X_0 X_1 C}(x_0, 0, 0) &= P_{X_0 X_1}(x_0, 0) \cdot P_{C|X_0 X_1}(0 | x_0, 0) \\ &= \min(P_{X_0 X_1}(x_0, 0), P_{X_0 X_1}(x_0, 1)) \\ &= P_{X_0 X_1 C}(x_0, 1, 0). \end{aligned}$$

Since  $X_0 \oplus X_1$  is uniformly distributed, we have

$$P_{X_0 X_1}(0, 0) - P_{X_0 X_1}(0, 1) = P_{X_0 X_1}(1, 0) - P_{X_0 X_1}(1, 1),$$

which implies that for  $C = 1$  and  $x_1 \in \{0, 1\}$ ,

$$\begin{aligned} P_{X_0 X_1 C}(0, x_1, 1) &= P_{X_0 X_1}(0, x_1) \cdot (1 - P_{C|X_0 X_1}(0 | 0, x_1)) \\ &= P_{X_0 X_1}(0, x_1) - \min(P_{X_0 X_1}(0, 0), P_{X_0 X_1}(0, 1)) \\ &= \max(0, P_{X_0 X_1}(0, x_1) - P_{X_0 X_1}(0, 1 - x_1)) \\ &= \max(0, P_{X_0 X_1}(1, x_1) - P_{X_0 X_1}(1, 1 - x_1)) \\ &= P_{X_0 X_1 C}(1, x_1, 1). \end{aligned}$$

Hence, for  $c \in \{0, 1\}$  and  $x_c \in \{0, 1\}$ ,

$$P_{X_{1-C} X_C C}(0, x_c, c) = P_{X_{1-C} X_C C}(1, x_c, c) = \frac{1}{2} P_{X_C C}(x_c, c).$$

Therefore,  $X_{1-C}$  is uniform with respect to  $(C, X_C)$ .  $\square$

**Lemma 6.4.** *If a protocol  $\mathbf{F}$  implements  $(\varepsilon, \varepsilon)$ -WOT in the malicious model, then it implements  $\binom{2}{1}$ -ROT<sup>1</sup> secure in the malicious model, with an error of at most  $\varepsilon/2$ .*

*Proof.* Let  $\mathcal{A} = \{\mathbf{B}\}$ . From Lemma 2.6 follows that there exists  $(X'_0, X'_1)$ , such that

$$\Delta((X_0, X_1, V), (X'_0, X'_1, V)) \leq \varepsilon/2$$

and  $X'_0 \oplus X'_1$  is uniform with respect to  $V$ . We choose  $P_{C|X'_0, X'_1, V}$  as proposed in Lemma 6.3.  $X'_{1-C}$  is uniform with respect to  $(C, X'_C, V)$ , and, therefore,  $X_{1-C}$  is  $\varepsilon/2$ -close to uniform with respect to  $(C, X_C, V)$ .

Let  $\mathcal{A} = \{\mathbf{A}\}$ . From Lemma 2.6 follows that  $C$  is  $\varepsilon/2$ -close to uniform with respect to  $U$ .

The lemma follows now from Theorem 4.2.  $\square$

### 6.1.3 Relation to Previous Definitions

**Difference to WOT from [DKS99, DFMS04].** Besides the fact that we only consider a randomized version of WOT, the difference of our definition of  $(p, q, \varepsilon)$ -WOT to the definitions used in [DKS99, DFMS04] is that we do not specify exactly what a malicious player may receive, but we only require that his output should not give too much information about the bits  $X_{1-C}$  and  $C$ . This means that a malicious player may, for example, always receive whether an error occurred in the transmission or not, if that information is independent of the inputs. The most important difference is, however, that our definitions do not require that the error must occur independently of the event that a player gets side information, which is very important when we want to apply it.

Lemmas 2.8 and 2.9 imply that our definitions still are quite close to the definitions from [DKS99, DFMS04], because there exist events with probability  $1 - p$  and  $1 - q$ , such that, if they occur, then the adversary does not get any side information.

**Connection to GWOT from [DFMS04].** In [DFMS04], *Generalized WOT* (GWOT) was introduced to improve the achievable range of the reductions. It was shown in Lemma 3 in [DFMS04] that in the reductions they used, WOT can be replaced by a GWOT, if the probability to guess the bits  $X_{1-C}$  and  $C$ , respectively, remain the same for the adversary. Since we defined WOT over the advantage to guess these values, Lemma 3 in [DFMS04] is not needed anymore, and therefore, at least for the moment, the use of GWOT does not give any advantage over WOT.

## 6.2 Impossibility Results

In this section we prove the impossibility result stated in [DKS99], that WOT cannot be amplified if  $p + q + 2\varepsilon \geq 1$ . Note that the proof does not work for the definition of WOT used in [DKS99, DFMS04]. We start with the protocol  $\text{SimWOT}_{(p,q)}(\text{Comm})$  that implements  $(p, q, \varepsilon)$ -WOT for  $p + q + 2\varepsilon = 1$  in the semi-honest model.

**Protocol 5.**  $\text{SimWOT}_A$ :

1. Choose  $(x'_0, x'_1) \in \{0, 1\}^2$  uniformly at random.
2. With probability  $q$ , send  $a = (x'_0, x'_1)$  to Comm. Otherwise, send  $a = \perp$  to Comm.
3. Receive  $b$ .
4. If  $b = \perp$  then output  $(x_0, x_1) := (x'_0, x'_1)$ . Otherwise,  $b = (c, y) \in \{0, 1\}^2$ . Output  $(x_0, x_1)$ , where  $x_c := y$  and  $x_{1-c} := x'_{1-c}$ .

SimWOT<sub>B</sub>:

1. Choose  $(c', y') \in \{0, 1\}^2$  uniformly at random.
2. Receive  $a$ .
3. If  $a = \perp$  then output  $(c, y) := (c', y')$  and send with probability  $p/(1-q)$  the value  $(c', y')$  to Comm, and  $\perp$  otherwise. Otherwise,  $a = (x'_0, x'_1) \in \{0, 1\}^2$ . Send  $\perp$  to Comm and outputs  $(c, y) := (c', x'_{c'})$ .

**Lemma 6.5.** *Protocol SimWOT<sub>(p,q)</sub>(Comm) securely implements  $(p, q, (1-p-q)/2)$ -WOT in the semi-honest model.*

*Proof.* Let  $E := Y \oplus X_C$ . With probability  $q$ , **B** will adjust his output such that  $Y = X_C$ , and with probability  $(1-q) \cdot p/(1-q) = p$ , **A** will adjust her output such that  $X_C = Y$ . With probability  $1-p-q$ , the values  $(X_0, X_1)$  and  $(C, Y)$  will be chosen uniformly at random. Therefore, we have

$$\Pr[Y \neq X_C] = (1-p-q)/2.$$

When SimWOT<sub>A</sub> sends  $\perp$  to Comm, then the value  $X_{1-C}$  is uniform with respect  $(V, E)$ . From Lemma 2.9 follows that

$$\text{PredAdv}(X_{1-C} \mid V, E) \leq q.$$

When SimWOT<sub>B</sub> sends  $\perp$  to Comm, then the value  $C$  is uniform with respect  $(U, E)$ . From Lemma 2.9 follows that

$$\text{PredAdv}(C \mid U, E) \leq p.$$

□



We need the following well-known fact.

**Lemma 6.6.** *There cannot exist a protocol  $\mathbf{P}(\text{Comm})$  that securely implements  $\binom{2}{1}\text{-OT}^1$  in the weak semi-honest model.*

**Theorem 6.1.** *For any  $p, q$ , and  $\varepsilon$  with  $p + q + 2\varepsilon \geq 1$  and for any  $n$ , there cannot exist a protocol  $\mathbf{P}((p, q, \varepsilon)\text{-WOT}^{\parallel n} \parallel \text{Comm})$  that securely implements  $\binom{2}{1}\text{-OT}^1$  in the semi-honest or the malicious model.*

*Proof.* From Lemma 3.1 follows that  $\mathbf{P}$  is secure in the weak semi-honest model. Therefore, it would follow from Lemma 6.5 and Theorem 3.3 that the protocol

$$\mathbf{P}(\text{SimWOT}_{(p,q)}(\text{Comm})^{\parallel n} \parallel \text{Comm})$$

would implement  $\binom{2}{1}\text{-OT}^1$  from scratch in the weak semi-honest model, which contradicts Lemma 6.6.  $\square$

## 6.3 Basic Protocols for WOT Amplification

We now present the three basic protocols that we use to implement ROT from WOT. The protocol R-Reduce allows for reducing the parameter  $p$ , and the protocol S-Reduce is used to reduce the parameter  $q$ . Both reductions were already used in [CK88, DKS99, DFMS04, Hai04], as well as in [HKN<sup>+</sup>05, MPW07] for building OT combiners. The protocol E-Reduce is used to reduce the parameter  $\varepsilon$ . Whereas the other two protocols are secure in both models, E-Reduce is merely secure in the semi-honest model. The same protocol was also used in [Hai04] and is the one-way variant of the protocol E-Reduce presented in [DKS99]. Notice that since we defined WOT to be a *randomized* primitive, we are not able to choose the input, which makes the protocols slightly more complicated.

We first present all protocols in the semi-honest model, and later give the proofs for the malicious model.

### 6.3.1 In the Semi-Honest Model

The protocol R-Reduce( $\text{WOT}^{\parallel n} \parallel \text{Comm}$ ) is defined as follows.

**Protocol 6.** R-Reduce<sub>A</sub>:

1. Receive  $(x_{0,i}, x_{1,i})$  from the  $i$ th WOT, for all  $i \in \{0, \dots, n-1\}$ .
2. Receive  $d^{n-1} = (d_0, \dots, d_{n-2})$  from Comm. Set  $d_{n-1} := 0$ .
3. Output  $(x_0, x_1) := (\bigoplus_{i=0}^{n-1} x_{d_i,i}, \bigoplus_{i=0}^{n-1} x_{d_i \oplus 1,i})$ .

R-Reduce<sub>B</sub>:

1. Receive  $(c_i, y_i)$  from the  $i$ th WOT, for all  $i \in \{0, \dots, n-1\}$ .
2. Send  $d^{n-1} = (d_0, \dots, d_{n-2})$  to Comm, where  $d_i := c_{n-1} \oplus c_i$ .
3. Output  $(c, y) := (c_{n-1}, \bigoplus_{i=0}^{n-1} y_i)$ .

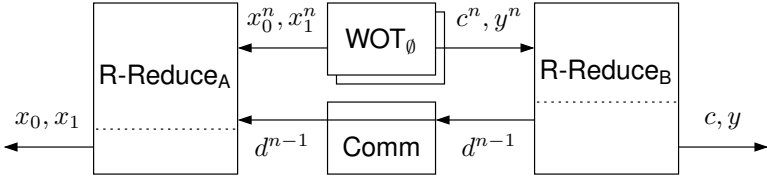

**Lemma 6.7.** *The protocol R-Reduce $((p, q, \varepsilon)$ -WOT $^{\parallel n}$  || Comm) securely implements  $(p', q', \varepsilon')$ -WOT in the semi-honest model, where  $p' = 1 - (1 - p)^n \leq np$ ,  $q' = q^n \leq e^{-n(1-q)}$ , and  $\varepsilon' = (1 - (1 - 2\varepsilon)^n)/2 \leq n\varepsilon$ .*

*Proof.* Let  $E_i := Y_i \oplus X_{C_i, i}$ , and  $E := Y \oplus X_C$ . We have

$$E = Y \oplus X_C = \bigoplus_{i=0}^{n-1} Y_i \oplus \bigoplus_{i=0}^{n-1} X_{C \oplus D_i, i} = \bigoplus_{i=0}^{n-1} (Y_i \oplus X_{C_i, i}) = \bigoplus_{i=0}^{n-1} E_i .$$

Let  $A = \emptyset$ . Since  $\Pr[E_i = 1] \leq \varepsilon$ , it follows from Lemma A.8 that

$$\Pr[E = 1] \leq \frac{1 - (1 - 2\varepsilon)^n}{2} \leq n\varepsilon .$$

Let  $A = \{B\}$ , and let  $V_i$  be the auxiliary output to B from the  $i$ th instance of  $WOT_{\{B\}}$ . The auxiliary output of the protocol to B is  $V := V^n$ . Since

$$X_{1-C} := \bigoplus_{i=0}^{n-1} X_{1-D_i \oplus C, i} = \bigoplus_{i=0}^{n-1} X_{1-C_i, i} ,$$

and because  $E$  is a function of  $E^n$ , it follows from Lemmas 2.7, 2.10 and A.4 that

$$\begin{aligned} \text{PredAdv}(X_{1-C} | V, E) &\leq \text{PredAdv}(X_{1-C} | V^n, E^n) \\ &= \prod_{i=0}^{n-1} \text{PredAdv}(X_{1-C_i, i} | V_i, E_i) \\ &\leq q^n \leq e^{-n(1-q)}. \end{aligned}$$

Let  $\mathcal{A} = \{\mathbf{A}\}$ , and let  $U_i$  be the auxiliary output to  $\mathbf{A}$  from the  $i$ th instance of  $\text{WOT}_{\{\mathbf{A}\}}$ . The auxiliary output of the protocol to  $\mathbf{A}$  is  $U := (U^n, D^{n-1})$ . Because  $E$  is a function of  $E^n$ , Lemmas 2.7, 2.11 and A.9 imply that

$$\begin{aligned} \text{PredAdv}(C | U, E) &\leq \text{PredAdv}(C | U^n, E^n, D^{n-1}) \\ &\leq 1 - \prod_{i=0}^{n-1} (1 - \text{PredAdv}(C_i | U_i, E_i)) \\ &\leq 1 - (1 - p)^n \leq np. \end{aligned}$$

□

We will also need a protocol **S-Reduce** that reduces the error  $p$ . To achieve this, we can simply use the protocol **R-Reduce** in the opposite direction, together with the protocol **ROT**. We need the fact that Protocol **ROT**(**WOT**) implements **WOT** in the inverse direction.

**Lemma 6.8.** *Protocol **ROT**(( $p, q, \varepsilon$ )-**WOT**) implements ( $q, p, \varepsilon$ )-**WOT** in the opposite direction, secure in the semi-honest model.*

*Proof.* Let  $(X'_0, X'_1, C', Y')$  be the output of  $\text{ROT}_\emptyset$ , and let  $(X_0, X_1, C, Y)$  be the output of **ROT**. Let  $U'$  be the auxiliary output to  $\mathbf{A}$  by  $\text{ROT}_{\{\mathbf{A}\}}$ , and let  $V'$  be the auxiliary output to  $\mathbf{B}$  by  $\text{ROT}_{\{\mathbf{B}\}}$ . The auxiliary output output to  $\mathbf{A}$  by **ROT** is  $V = U'$ , and the auxiliary output to  $\mathbf{B}$  by **ROT** is  $U = V'$ .

Let  $E := Y \oplus X_C$ . It is easy to verify that  $E' = Y' \oplus X'_{C'} = E$ , and therefore that the correctness condition is satisfied. From Lemma 2.12 follows that

$$\begin{aligned} \text{PredAdv}(X_{1-C} | V, E) &= \text{PredAdv}(X_{1-C} \oplus (E \oplus Y) | V, E) \\ &= \text{PredAdv}(X_{1-C} \oplus X_C | V, E') \\ &= \text{PredAdv}(C' | U', E') \leq p \end{aligned}$$

and

$$\begin{aligned}
\text{PredAdv}(C \mid U, E) &= \text{PredAdv}(X'_0 \oplus X'_1 \mid V', E') \\
&= \text{PredAdv}(X'_{1-C'} \oplus X'_{C'} \mid V', E') \\
&= \text{PredAdv}(X'_{1-C'} \mid V', E') \leq q.
\end{aligned}$$

□

We can, therefore, implement S-Reduce in the following way: We apply ROTOR to all  $n$  instances of WOT, then use R-Reduce in the opposite direction, and finally apply ROTOR to the resulting WOT. We get

**Lemma 6.9.** *The protocol S-Reduce( $(p, q, \varepsilon)$ -WOT $^{\parallel n}$  || Comm) securely implements  $(p', q', \varepsilon')$ -WOT in the semi-honest model, where  $q' = 1 - (1 - q)^n \leq nq$ ,  $p' = p^n \leq e^{-n(1-p)}$ , and  $\varepsilon' = (1 - (1 - 2\varepsilon)^n)/2 \leq n\varepsilon$ .*

Protocol E-Reduce(WOT $^{\parallel n}$  || Comm) reduces the error  $\varepsilon$ , and is defined as follows.

**Protocol 7. E-Reduce<sub>A</sub>:**

1. Receive  $(x_{0,i}, x_{1,i})$  from the  $i$ th WOT, for all  $i \in \{0, \dots, n-1\}$ .
2. Receive  $d^{n-1} = (d_0, \dots, d_{n-2})$  from Comm.
3. Send  $(s_0^{n-1}, s_1^{n-1}) = ((s_{0,0}, \dots, s_{0,n-2}), (s_{1,0}, \dots, s_{1,n-2}))$  to Comm, where  $s_{j,i} := x_{d_i \oplus j, i} \oplus x_{j, n-1}$ .
4. Output  $x_0 := x_{0, n-1}$  and  $x_1 := x_{1, n-1}$ .

E-Reduce<sub>B</sub>:

1. Receive  $(c_i, y_i)$  from the  $i$ th WOT, for all  $i \in \{0, \dots, n-1\}$ .
2. Send  $d^{n-1} = (d_0, \dots, d_{n-2})$  to Comm, where  $d_i := c_{n-1} \oplus c_i$ .
3. Receive  $(s_0^{n-1}, s_1^{n-1})$  from Comm.
4. Output  $(c, y) := (c_{n-1}, \text{maj}(\{\bar{y}_i\}))$  where  $\bar{y}_i := y_i \oplus s_{c_{n-1}, i}$  for  $i \in \{0, \dots, n-2\}$  and  $\bar{y}_{n-1} := y_{n-1}$ .

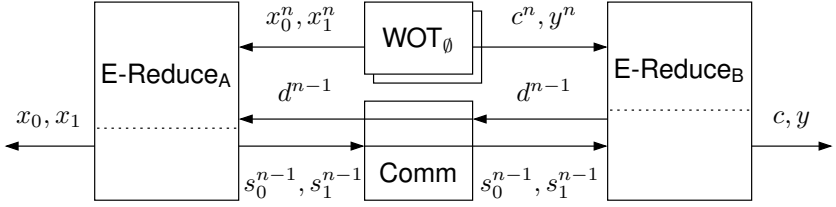

**Lemma 6.10.** *Protocol  $E\text{-Reduce}((p, q, \varepsilon)\text{-WOT}^{\parallel n} \parallel \text{Comm})$  securely implements  $(p', q', \varepsilon')\text{-WOT}$  in the semi-honest model, where  $p' = 1 - (1 - p)^n \leq np$ ,  $q' = 1 - (1 - q)^n \leq nq$  and*

$$\varepsilon' = \sum_{i=\lceil n/2 \rceil}^n \binom{n}{i} \varepsilon^i (1 - \varepsilon)^{n-i} \leq e^{-2n(1/2-\varepsilon)^2}.$$

*Proof.* Let  $E_i := Y_i \oplus X_{C_i, i}$ , and  $E := Y \oplus X_C$ .

Let  $\mathcal{A} = \emptyset$ . We have  $\Pr[E_i = 1] \leq \varepsilon$ . Since for  $i \in \{0, \dots, n-2\}$

$$\begin{aligned} \bar{Y}_i &= Y_i \oplus S_{C_{n-1}, i} = Y_i \oplus X_{D_i \oplus C_{n-1}, i} \oplus X_{C_{n-1}, n-1} \\ &= Y_i \oplus X_{C_i, i} \oplus X_C = E_i \oplus X_C, \end{aligned}$$

it follows from Lemma A.10 that the protocol satisfies correctness with an error of at most

$$\varepsilon' = \sum_{i=\lceil n/2 \rceil}^n \binom{n}{i} \varepsilon^i (1 - \varepsilon)^{n-i} \leq e^{-2n(1/2-\varepsilon)^2}.$$

Let  $\mathcal{A} = \{\mathbf{B}\}$ . Let  $V_i$  be the auxiliary output to  $\mathbf{B}$  from the  $i$ th instance of  $\text{WOT}_{\{\mathbf{B}\}}$ . The auxiliary output to  $\mathbf{B}$  is  $V = (D^{n-1}, S_0^{n-1}, S_1^{n-1}, V^n)$ . Note that  $D^{n-1}$  is a function of  $V^n$ . Furthermore,  $S_C^{n-1}$  is a function of  $(V^n, E^n)$ , because

$$\begin{aligned} S_{C, i} &= X_{D_i \oplus C_{n-1}, i} \oplus X_{C_{n-1}, n-1} = X_{C_i, i} \oplus X_{C_{n-1}, n-1} \\ &= Y_i \oplus E_i \oplus Y_{n-1} \oplus E_{n-1}, \end{aligned}$$

for all  $i$ . Since

$$X_{1-C} = X_{1-C, n-1} = S_{1-C, i} \oplus X_{1-D_i \oplus C, i} = S_{1-C, i} \oplus X_{1-C_i, i},$$

Lemmas 2.7, 2.11 and A.9 imply

$$\begin{aligned} \text{PredAdv}(X_{1-C} \mid V, E) &\leq \text{PredAdv}(X_{1-C} \mid V^n, E^n, S_{1-C}^{n-1}) \\ &\leq 1 - \prod_{i=0}^{n-1} (1 - \text{PredAdv}(X_{1-C_i, i} \mid V_i, E_i)) \\ &\leq 1 - (1 - q)^n \leq nq . \end{aligned}$$

Let  $\mathcal{A} = \{\mathbf{A}\}$ , and let  $U_i$  be the auxiliary output to  $\mathbf{A}$  from the  $i$ th instance of  $\text{WOT}_{\{\mathbf{A}\}}$ . The auxiliary output of the protocol to  $\mathbf{A}$  is  $U := (U^n, D^{n-1})$ . Because  $E$  is a function of  $E^n$ , it follows from Lemmas 2.7, 2.11 and A.9 that

$$\begin{aligned} \text{PredAdv}(C \mid U, E) &\leq \text{PredAdv}(C \mid U^n, E^n, D^{n-1}) \\ &\leq 1 - \prod_{i=0}^{n-1} (1 - \text{PredAdv}(C_i \mid U_i, E_i)) \\ &\leq 1 - (1 - p)^n \leq np . \end{aligned}$$

□

### 6.3.2 In the Malicious Model

We will now show that the protocols R-Reduce and S-Reduce are also secure in the malicious model, for the same parameters as in the semi-honest model.

**Lemma 6.11.** *Protocol R-Reduce( $(p, q)$ -WOT $^{\parallel n} \parallel \text{Comm}$ ) securely implements  $(p', q')$ -WOT in the malicious model, where  $p' = 1 - (1 - p)^n \leq np$  and  $q' = q^n \leq e^{-n(1-q)}$ .*

*Proof.* Let  $\mathcal{A} = \emptyset$ . It is easy to verify that  $X_0$ ,  $X_1$ , and  $C$  are uniformly distributed. Further, we have

$$Y = \bigoplus_{i=0}^{n-1} Y_i = \bigoplus_{i=0}^{n-1} X_{C_i, i} = \bigoplus_{i=0}^{n-1} X_{D_i \oplus C, i} = X_C .$$

Hence, the protocol achieves correctness.

Let  $\mathcal{A} = \{\mathbf{A}\}$ , and let  $U_i$  be the transcript of the interaction with player  $\mathbf{A}$  by the  $i$ th instance of WOT. The transcript of the interaction with  $\mathbf{A}$  of the protocol is  $U := (U^n, D^{n-1})$ . From Lemma 2.11 and A.9 follows that

$$\begin{aligned} \text{PredAdv}(C \mid U) &\leq \text{PredAdv}(C \mid U^n, D^{n-1}) \\ &\leq 1 - \prod_{i=0}^{n-1} (1 - \text{PredAdv}(C_i \mid U_i)) \\ &\leq 1 - (1 - p)^n \leq np. \end{aligned}$$

Let  $\mathcal{A} = \{\mathbf{B}\}$ , and let  $V_i$  be the transcript of the interaction with player  $\mathbf{B}$  by the  $i$ th instance of WOT. The transcript of the interaction with  $\mathbf{B}$  of the protocol is  $V := (V^n, D^{n-1})$ . Note that since  $D^{n-1}$  is a probabilistic function of  $V$  it can be ignored. It follows from Lemmas 2.10 and A.4 that

$$\begin{aligned} \text{PredAdv}(X_0 \oplus X_1 \mid V) &\leq \text{PredAdv}\left(\bigoplus_{i=0}^{n-1} X_{D_i \oplus 0, i} \oplus \bigoplus_{i=0}^{n-1} X_{D_i \oplus 1, i} \mid V^n\right) \\ &\leq \text{PredAdv}\left(\bigoplus_{i=0}^{n-1} (X_{0, i} \oplus X_{1, i}) \mid V^n\right) \\ &= \prod_{i=0}^{n-1} \text{PredAdv}(X_{0, i} \oplus X_{1, i} \mid V_i) \\ &\leq q^n \leq e^{-n(1-q)}. \end{aligned}$$

□

The proof that ROTOR(WOT) implements WOT in the opposite direction is very simple.

**Lemma 6.12.** *ROTOR( $(p, q, \varepsilon)$ -WOT) implements  $(q, p, \varepsilon)$ -WOT in the opposite direction, secure in the malicious model.*

*Proof.* It is easy to verify that the correctness condition is satisfied. Furthermore, we have

$$\begin{aligned} \text{PredAdv}(X_0 \oplus X_1 \mid U) &= \text{PredAdv}(C' \mid U) \leq p \\ \text{PredAdv}(C \mid V) &= \text{PredAdv}(X'_0 \oplus X'_1 \mid V) \leq q. \end{aligned}$$

□

In the same way as in the passive case, we can implement S-Reduce by first applying ROTOR to all  $n$  instances of WOT, then use R-Reduce in the opposite direction, and by finally applying ROTOR. We get

**Lemma 6.13.** *Protocol S-Reduce( $(p, q)$ -WOT $^{\parallel n}$  || Comm) securely implements  $(p', q')$ -WOT in the semi-honest model, where  $q' = 1 - (1 - q)^n \leq nq$  and  $p' = p^n \leq e^{-n(1-p)}$ .*

## 6.4 WOT Amplification if $\varepsilon = 0$

We will now present several protocols that implement ROT from WOT. We start with the special case where  $p, q > 0$ , but  $\varepsilon = 0$ . In [DKS99], a protocol for this case is presented that works for all values  $p$  and  $q$  if  $p + q < 1$ , which is optimal. We present a slightly simplified protocol and give a more detailed analysis of its efficiency.

The main part of the reduction is the following lemma, which shows that we can implement a  $(p', q')$ -WOT out of 4 instances of  $(p, q)$ -WOT, where the value  $1 - (1 - p - q)^2$  is squared.

**Lemma 6.14.** *Let  $f(p, q) := 1 - (1 - p - q)^2$ , and let  $p + q < 1$ . We can securely implement  $(p', q')$ -WOT out of 4 instances of  $(p, q)$ -WOT with*

$$f(p', q') \geq f^2(p, q) ,$$

*secure in the semi-honest and the malicious model.*

*Proof.* It suffices to show that

$$1 - p' - q' \geq \sqrt{2 - (1 - p - q)^2} \cdot (1 - p - q) ,$$

since then

$$\begin{aligned} f(p', q') &= 1 - (1 - p' - q')^2 \\ &\leq 1 - (2 - (1 - p - q)^2)(1 - p - q)^2 \\ &= f^2(p, q) . \end{aligned}$$

Twice, we apply either the protocol R-Reduce(WOT $^{\parallel 2}$  || Comm) or protocol S-Reduce(WOT $^{\parallel 2}$  || Comm), such that each time the larger of the two parameter gets reduced.



Since the protocols are symmetric, we can assume that  $p > q$ . Therefore, the first protocol that will be applied is **S-Reduce**. We have to distinguish between two cases. If  $p^2 \geq 1 - (1 - q)^2 = 2q - q^2$ , then also the second protocol is **S-Reduce**, and, therefore,

$$p' = p^4, \quad q' = 1 - (1 - q)^4.$$

Let

$$\begin{aligned} f_1(p, q) &:= \frac{1 - p' - q'}{1 - p - q} = \frac{(1 - q)^4 - p^4}{1 - p - q} \\ &= p^3 + p^2(1 - q) + (1 - q)^2 p + (1 - q)^3 \end{aligned}$$

and

$$g_1(p, q) := f_1(p, q) - (1 + p - q) = (p^2 - 2q + q^2)(1 + p - q).$$

We will now show that  $f_1(p, q) \geq \sqrt{2 - (1 - p - q)^2}$  if  $p^2 \geq 2q - q^2$ . Since for  $0 < p < 1$  and  $0 < q < 1$ , we have  $1 + p - q > 0$ . It follows that  $g_1(p, q) \geq 0$  for all  $p$  and  $q$  that satisfy  $p^2 \geq 2q - q^2$  and, therefore, also

$$f_1(p, q) \geq 1 + p - q$$

for all these values. Hence, it suffices to show that

$$1 + p - q \geq \sqrt{2 - (1 - p - q)^2}$$

for  $p^2 \geq 2q - q^2$ .

Let us fix the value  $d := 1 - p - q$ . We have  $1 + p - q = 2p + d$ , and thus  $1 + p - q$  is minimal for  $p^2 = 2q - q^2$ . It is taken on by the values  $q_0$  and  $p_0 = \sqrt{2q_0 - q_0^2}$ , which can be calculated by solving the equation  $\sqrt{2q_0 - q_0^2} + q_0 = 1 - d$ , which is equal to  $2q_0^2 - (4 - 2d)q_0 + (1 - 2d + d^2) = 0$ . We get

$$q_0 = \frac{(4 - 2d) - \sqrt{(4 - 2d)^2 - 4 \cdot 2 \cdot (1 - 2d + d^2)}}{4} = \frac{2 - d - \sqrt{2 - d^2}}{2}.$$

So, for  $p + q = 1 - d$ , we have

$$f_1(p, q) \geq 1 + (1 - d - q_0) - q_0 = 2 - d - (2 - d - \sqrt{2 - d^2}) = \sqrt{2 - d^2}.$$

If  $p^2 < 2q - q^2$ , the second protocol will be R-Reduce, and, therefore,

$$\begin{aligned} p' &= 1 - (1 - p^2)^2 = 2p^2 - p^4, \\ q' &= (1 - (1 - q)^2)^2 = 4q^2 - 4q^3 + q^4. \end{aligned}$$

Let

$$\begin{aligned} f_2(p, q) &:= \frac{1 - p' - q'}{1 - p - q} = \frac{1 - 2p^2 + p^4 - 4q^2 + 4q^3 - q^4}{1 - p - q} \\ &= q^3 - 3q^2 - q^2p + q + 2qp + qp^2 + 1 + p - p^2 - p^3. \end{aligned}$$

We will now show that  $f_2(p, q) \geq \sqrt{2 - d^2}$  for  $p^2 \leq 2q + q^2$ . Let

$$g_2(p, q) := f_2(p, q) - (1 + p - q) = (p^2 - 2q + q^2)(q - p - 1),$$

which is equal to 0 if  $p^2 = 2q + q^2$ . Therefore, we have

$$f_2(p, q) = 1 + p - q = f_1(p, q)$$

for all  $p$  and  $q$  that satisfy  $p^2 = 2q + q^2$ . Again, let us fix  $d := 1 - p - q$  and let

$$\begin{aligned} h_2(q) &:= f_2(1 - d - q, q) \\ &= 4q^3 - (12 - 6d)q^2 + (8 - 12d + 4d^2)q + 4d - 4d^2 + d^3. \end{aligned}$$

We differentiate  $h_2(q)$  twice, and get

$$\begin{aligned} h_2'(q) &= 12q^2 - (24 - 12d)q + 8 - 12d + 4d^2, \\ h_2''(q) &= 24q - 24 - 12d. \end{aligned}$$

Since  $h_2''(q) \leq 24q - 24 < 0$  for  $q < 1$ ,  $h_2(q)$  is concave for  $0 \leq q \leq 1$  and  $p^2 \leq 2q + q^2$ . It will therefore take on its minimum on a point on the bound. On one side, we have  $p^2 = 2q - q^2$ , and therefore  $q_0$  (see above) is the value on the bound, for which we have  $h_2(q_0) = \sqrt{2 - d^2}$ . On the other side,  $q_1 = (1 - d)/2$  is the value on the bound, for which we have

$$h_2((1 - d)/2) = \frac{3 - d^2}{2}.$$

For all  $d$  we have

$$\frac{3 - d^2}{2} = \sqrt{\frac{(d^2 - 1)^2}{4} + (2 - d^2)} \geq \sqrt{2 - d^2},$$

so the minimum is always in  $q_0$ . Therefore, both  $f_1(p, q)$  and  $f_2(p, q)$  take on their minimum in  $(1 - d - q_0, q_0)$ , and are always larger than  $\sqrt{2 - d^2}$ . The statement follows.  $\square$

**Theorem 6.2.** *Let  $p(k)$  and  $q(k)$  be functions computable in time  $\text{poly}(k)$  such that  $p(k) + q(k) < 1$  for all  $k$ .  $(2^{-k}, 2^{-k})$ -WOT can efficiently be implemented using*

$$\frac{2 \cdot k^2}{(1 - p(k) - q(k))^4}$$

*instances of  $(p, q)$ -WOT, secure in the semi-honest and the malicious model.*

*Proof.* We apply  $t$  times Lemma 6.14, which gives us a  $(p', q')$ -WOT with  $f(p', q') \leq f^{(2^t)}(p, q)$ . Using Lemmas A.4 and A.5, we get

$$\begin{aligned} p' + q' &= 1 - \sqrt{1 - f(p', q')} \leq 1 - \sqrt{1 - f^{(2^t)}(p, q)} \leq f^{(2^t)}(p, q) \\ &\leq \exp(-2^t(1 - f(p, q))) = \exp(-2^t(1 - p - q)^2). \end{aligned}$$

To satisfy  $p' + q' \leq 2^{-k}$ , we choose

$$t := \left\lceil \log \left( \frac{-\ln(2^{-k})}{(1 - p - q)^2} \right) \right\rceil \leq \log \left( \frac{\ln(2) \cdot k}{(1 - p - q)^2} \right) + 1.$$

Our protocol requires

$$4^t \leq \frac{4 \cdot \ln^2(2) \cdot k^2}{(1 - p - q)^4} \leq \frac{2 \cdot k^2}{(1 - p - q)^4}$$

instances of  $(p, q)$ -WOT. □

**OT-Combiners.** As shown in [HKN<sup>+</sup>05, MPW07], Theorem 6.2 can be used to implement an efficient  $(\alpha, \beta; n)$ -robust oblivious transfer combiner. We have  $n$  different implementations of OT, out of which  $\alpha$  are secure for the sender, and  $\beta$  are secure for the receiver, where  $\alpha + \beta > n$ . Choosing randomly one of these  $n$  different implementations of OT and using random inputs implements a  $(p, q)$ -WOT for  $p = (n - \beta)/n$ , and  $q = (n - \alpha)/n$ . Since  $1 - p - q \geq 1/n$ , we can implement a  $(2^{-k}, 2^{-k})$ -WOT using  $2k^2n^4$  instances of the weak implementations of OT, and common randomness.

## 6.5 WOT Amplification if $p = 0$ or $q = 0$

We will now look at the special case where  $\varepsilon > 0$ , but either  $p = 0$  or  $q = 0$ . This special case has not been considered in [DKS99]. There is a

strong connection of this problem to the one-way key-agreement problem studied in [HR05, Hol06], as well as to the statistical-distance polarization problem studied in [SV99, Vad99].

We will make the amplification in two steps. First, in Lemma 6.15 (which is related to Lemma 4.13 in [Hol06]), we implement a WOT with constant errors. In Lemma 6.16 (related to Lemma 4.1 in [SV99]), we show how the error can be made arbitrarily small.

**Lemma 6.15.** *Let  $q(k)$  and  $\varepsilon(k)$  be functions computable in time  $\text{poly}(k)$  such that  $\sqrt{q(k)} + 2\varepsilon(k) < 1$  for all  $k$ . Let*

$$\lambda := \max \left( 1, \frac{1}{\log((1 - 2\varepsilon)^2/q)} \right).$$

*Then  $(0, 1/3, 1/50)$ -WOT can efficiently be implemented using at most*

$$\frac{128\lambda}{(1 - 2\varepsilon)^{(12\lambda)}}$$

*instances of  $(0, q, \varepsilon)$ -WOT secure in the semi-honest model.*

*Proof.* Let  $\alpha = 1 - 2\varepsilon$  and  $\beta = \max(q, \alpha^2/2)$ . Note that  $\lambda = 1/\log(\alpha^2/\beta)$ . We use

$$\mathbf{G} = \mathbf{R}\text{-Reduce}(\mathbf{F}^{\parallel s} \parallel \text{Comm}),$$

$$\mathbf{H} = \mathbf{E}\text{-Reduce}(\mathbf{G}^{\parallel r} \parallel \text{Comm})$$

for  $s := \lceil 5\lambda \rceil$  and  $r := \lceil 1/(4\beta^s) \rceil$ . Notice that  $s < 5\lambda + 1 \leq 6\lambda$ . Further, since  $s > 5/\log(\alpha^2/\beta) > 5/\log(1/\beta) = \log_\beta(1/32)$ , we get

$$r < \frac{1}{4\beta^s} + 1 = \frac{1 + 4\beta^s}{4\beta^s} < \frac{1 + 4/32}{4\beta^s} = \frac{9}{32\beta^s} < \frac{1}{3\beta^s}.$$

Using Lemmas 6.7 and 6.10, we get that  $\mathbf{G}$  is a  $(0, \beta', (1 - \alpha')/2)$ -WOT with  $\beta' = \beta^s$  and  $\alpha' = \alpha^s$ , and  $\mathbf{H}$  is a  $(0, q'', \varepsilon'')$ -WOT with

$$\begin{aligned} \varepsilon'' &\leq \exp \left( -2r \left( \frac{1}{2} - \frac{1 - \alpha'}{2} \right)^2 \right) \leq \exp \left( -r \frac{\alpha^{2s}}{2} \right) \\ &\leq \exp \left( -\frac{\alpha^{2s}}{8\beta^s} \right) = \exp \left( -\frac{1}{8} \left( \frac{\alpha^2}{\beta} \right)^s \right) \\ &\leq \exp \left( -\frac{1}{8} 2^{\log(\alpha^2/\beta) \frac{5}{\log(\alpha^2/\beta)}} \right) = \exp(-32/8) < 1/50 \end{aligned}$$

and, using that  $r < 1/(3\beta^s)$ , we get  $q'' \leq r\beta' \leq r\beta^s < 1/3$ .

Finally, the number of instances used is  $s \cdot r$ , which is at most

$$6\lambda \cdot \frac{1}{3\beta^{6\lambda}} = \frac{2\lambda}{\beta^{6\lambda}} = \frac{128\lambda}{\alpha^{12\lambda}},$$

since  $2^{1/\lambda} = \alpha^2/\beta$  and thus  $\beta^{6\lambda} = \alpha^{12\lambda}/64$ .  $\square$

**Lemma 6.16.**  $(0, 2^{-k}, 2^{-k})$ -WOT can efficiently be implemented using

$$116 \cdot \log(20k) \cdot k^{\log 3+1} = O(k^{2.6})$$

instances of  $(0, 1/3, 1/11)$ -WOT secure in the semi-honest model.

*Proof.* Let  $\beta = 1/3$ , and  $\alpha = 1 - 2 \cdot 1/11 = 9/11$ . Let  $\ell = \lceil \log(4k + 4 \log k) \rceil$  and  $m = 3^\ell/2$ . We use the reductions

$$\mathbf{G} = \text{R-Reduce}(\mathbf{F}^{\parallel \ell} \parallel \text{Comm}),$$

$$\mathbf{H} = \text{E-Reduce}(\mathbf{G}^{\parallel m} \parallel \text{Comm}),$$

$$\mathbf{I} = \text{R-Reduce}(\mathbf{H}^{\parallel k} \parallel \text{Comm}).$$

Using Lemmas 6.7 and 6.10 and since  $\mathbf{F}$  is a  $(0, \beta, (1 - \alpha)/2)$ -WOT,  $\mathbf{G}$  is a  $(0, \beta', (1 - \alpha')/2)$ -WOT, where  $\beta' = \beta^\ell$  and  $\alpha' = \alpha^\ell$ .  $\mathbf{H}$  is a  $(0, \beta'', \varepsilon'')$ -WOT with

$$\beta'' \leq m\beta' = 3^\ell/2 \cdot (1/3)^\ell = 1/2$$

and, since  $3 \cdot \alpha^2 > 2$ ,

$$\begin{aligned} \varepsilon'' &\leq \exp\left(-2m \left(\frac{1}{2} - \frac{1 - \alpha'}{2}\right)^2\right) = \exp\left(-3^\ell \cdot \frac{(\alpha^\ell)^2}{4}\right) \\ &= \exp\left(-\frac{3 \cdot \alpha^2}{4}\right)^\ell \leq \exp\left(-\frac{2^\ell}{4}\right) \leq \exp(-k - \log k) < 2^{-k - \log k}. \end{aligned}$$

Finally,  $\mathbf{I}$  is a  $(0, \beta''', \varepsilon''')$ -WOT with  $\varepsilon''' \leq k2^{-k - \log k} = 2^{-k}$  and  $\beta''' \leq 2^{-k}$ .

From Lemma A.4 follows that

$$4k + 4 \log k = 4k + 4 \ln(k)/\ln(2) \leq 4k + (4k - 1)/\ln(2) \leq 10k.$$

The number of instances used is, using Lemma A.4,

$$\begin{aligned} \ell \cdot m \cdot k &\leq (\log(4k + 4 \log k) + 1) \cdot 3^{\log(4k + 4 \log k) + 1} \cdot k \\ &\leq (\log(10k) + 1) \cdot 3 \cdot (10k)^{\log 3} \cdot k \\ &\leq 116 \cdot \log(20k) \cdot k^{\log 3 + 1} = O(k^{2.6}) . \end{aligned}$$

□

Combining Lemma 6.15 and Lemma 6.16, we get the following theorem.

**Theorem 6.3.** *Let  $q(k)$  and  $\varepsilon(k)$  be functions computable in time  $\text{poly}(k)$  such that  $\sqrt{q(k)} + 2\varepsilon(k) < 1$  for all  $k$ . Let*

$$\lambda := \max \left( 1, \frac{1}{\log((1 - 2\varepsilon)^2/q)} \right) .$$

$(0, 2^{-k}, 2^{-k})$ -WOT can efficiently be implemented using at most

$$O \left( \frac{k^{2.6} \lambda}{(1 - 2\varepsilon)^{(12\lambda)}} \right)$$

instances of  $(0, q, \varepsilon)$ -WOT secure in the semi-honest model.

Since R-Reduce and S-Reduce are symmetrical, we immediately get

**Corollary 6.1.** *Let  $p(k)$  and  $\varepsilon(k)$  be functions computable in time  $\text{poly}(k)$  such that  $\sqrt{p(k)} + 2\varepsilon(k) < 1$  for all  $k$ . Let*

$$\lambda := \max \left( 1, \frac{1}{\log((1 - 2\varepsilon)^2/p)} \right) .$$

$(2^{-k}, 0, 2^{-k})$ -WOT can efficiently be implemented using at most

$$O \left( \frac{k^{2.6} \lambda}{(1 - 2\varepsilon)^{(12\lambda)}} \right)$$

instances of  $(p, 0, \varepsilon)$ -WOT secure in the semi-honest model.

Since any protocol (using our basic protocols) for the special cases where either  $p = 0$  or  $q = 0$  can directly be translated into a one-way key-agreement protocol for distributions studied in [HR05], it follows from Theorem 4 in [HR05] that using our basic protocols, this is the best bound that we can achieve. However, it is not clear whether other reductions, would be able to achieve a better bound.

## 6.6 WOT Amplification if $p, q, \varepsilon > 0$ .

To find an optimal protocol for the general case where all three parameters are non-zero turns out to be much harder than the other three special cases. It is still unknown what the exact bound is in this case. In this section we present some partial results.

We start with the case where all values are non-zero, but smaller than  $1/50$ .

**Lemma 6.17.**  $(2^{-k}, 2^{-k}, 2^{-k})$ -WOT can efficiently be implemented using

$$175 \cdot k^{2+\log(3)} \leq 175 \cdot k^{3.6}$$

instances of  $(1/50, 1/50, 1/50)$ -WOT secure in the semi-honest model.

*Proof.* We set  $\mathbf{F}_0 := (p, q, \varepsilon)$ -WOT and iterate the reduction

$$\mathbf{F}_{i+1} := \text{S-Reduce}(\text{R-Reduce}(\text{E-Reduce}(\mathbf{F}_i^{\parallel 3} \parallel \text{Comm})^{\parallel 2} \parallel \text{Comm})^{\parallel 2} \parallel \text{Comm}),$$

until  $\mathbf{F}_j$  is a  $(p_j, q_j, \varepsilon_j)$ -WOT with  $\max(p_j, q_j, \varepsilon_j) \leq 2^{-k}$ . In every iteration, we have  $p_{i+1} \leq (2 \cdot (3p_i))^2 = 36p_i^2$ ,  $q_{i+1} \leq 2 \cdot ((3q_i)^2) = 18q_i^2$ , and  $\varepsilon_{i+1} \leq 2 \cdot 2 \cdot (3\varepsilon^2 - 2\varepsilon^3) \leq 12\varepsilon^2$ , from which follows that

$$\max(p_j, q_j, \varepsilon_j) \leq 36^{2^j-1} \cdot \frac{1}{50^{2^j}} = \frac{1}{36} \left( \frac{36}{50} \right)^{2^j} \leq \left( \frac{36}{50} \right)^{2^j}.$$

To achieve  $\max(p_j, q_j, \varepsilon_j) \leq 2^{-k}$ , we choose

$$j := \left\lceil \log \frac{k}{\log(50/36)} \right\rceil \leq \log(2.1101 \cdot k) + 1 = \log(4.2202 \cdot k).$$

To implement one instance of  $\mathbf{F}_j$ , we need at most

$$12^j \leq (4.2202 \cdot k)^{\log(12)} \leq 175 \cdot k^{2+\log(3)} \leq 175 \cdot k^{3.6}$$

instances of  $\mathbf{F}_0$ . □

We will now give a similar bound as in Lemma 5 in [DKS99], which was  $p + q + 2\varepsilon \leq 0.45$ . But since our protocol E-Reduce is different, we are only able to achieve a smaller bound. As in [DKS99], we are only able

to obtain our bound using a simulation. Our simulation works as follows: Let  $l_i(p, q)$  be a function such that for all  $p, q$  and  $\varepsilon < l_i(p, q)$ ,  $(1/50, 1/50, 1/50)$ -WOT can be implemented using  $(p, q, \varepsilon)$ -WOT. Using  $l_i(p, q)$ , we define

$$l_{i+1}(p, q) := \max(S_\varepsilon^{-1}(l_i(S_p(p), S_q(q))), R_\varepsilon^{-1}(l_i(R_p(p), R_q(q))), \\ E_\varepsilon^{-1}(l_i(E_p(p), E_q(q)))) ,$$

where

$$S_p(p) := p^2, \quad S_q(q) := 1 - (1 - q)^2, \quad S_\varepsilon^{-1}(\varepsilon) := (1 - \sqrt{1 - 2\varepsilon})/2,$$

$$R_p(p) := 1 - (1 - p)^2, \quad R_q(q) := q^2, \quad R_\varepsilon^{-1}(\varepsilon) := (1 - \sqrt{1 - 2\varepsilon})/2,$$

$$E_p(p) := 1 - (1 - p)^3, \quad E_q(q) := 1 - (1 - q)^3,$$

and  $E_\varepsilon^{-1}(\varepsilon)$  is the inverse of  $E_\varepsilon(\varepsilon) := 3\varepsilon^2 - 2\varepsilon^3$ .

Now, for all  $p, q$  and  $\varepsilon < l_{i+1}(p, q)$ ,  $(1/50, 1/50, 1/50)$ -WOT can be implemented using  $(p, q, \varepsilon)$ -WOT, since applying one of the three protocols S-Reduce( $(p, q, \varepsilon)$ -WOT $^{\|2\|}$ Comm), R-Reduce( $(p, q, \varepsilon)$ -WOT $^{\|2\|}$ Comm), or E-Reduce( $(p, q, \varepsilon)$ -WOT $^{\|3\|}$ Comm) gives us an instance of  $(p', q', \varepsilon')$ -WOT with  $\varepsilon' < l_i(p', q')$ , from which  $(1/50, 1/50, 1/50)$ -WOT can be implemented.

Obviously,  $l_0(p, q) := (0.02 - p - q)/2$  satisfies our condition. Iterating 8 times, we get  $l_8(p, q)$ , where for all  $p, q$  we have  $l_8(p, q) \geq (0.15 - p - q)/2$ . Using  $l'_0(p, q) := (0.15 - p - q)/2$  and iterating 11 times, we get  $l'_{11}(p, q)$ , where for all  $p, q$  we have  $l'_{11}(p, q) \geq (0.24 - p - q)/2$  (See also Figure 6.2).

**Lemma 6.18.** *If  $p + q + 2\varepsilon \leq 0.24$ , then  $(1/50, 1/50, 1/50)$ -WOT can efficiently be implemented using  $O(1)$  instances of  $(p, q, \varepsilon)$ -WOT, secure in the semi-honest model.*

We will now further extend this result and give bounds for the cases where one of the three values is large, while the others are small.

**Lemma 6.19.** *If  $p + 22q + 44\varepsilon < 1$ , then  $(p', q', \varepsilon')$ -WOT with  $p' + q' + 2\varepsilon' \leq 0.24$  can efficiently be implemented using  $4/(1 - p)$  instances of  $(p, q, \varepsilon)$ -WOT, secure in the semi-honest model.*



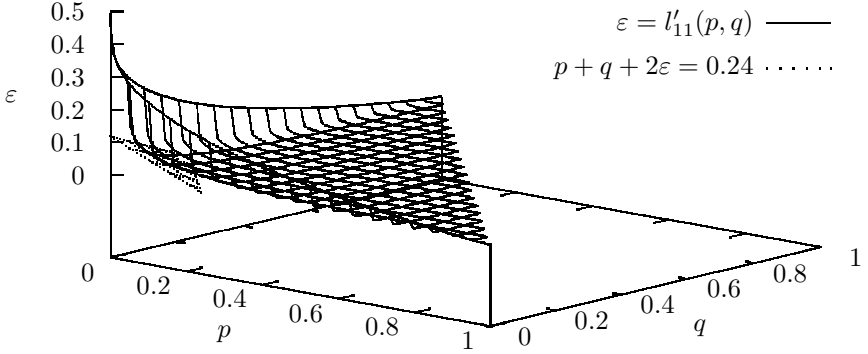

**Figure 6.2:** Plot of the bounds  $\varepsilon = l'_{11}(p, q)$  and  $p + q + 2\varepsilon = 0.24$ .

*Proof.* We apply

$$\mathbf{F} = \text{S-Reduce}((p, q, \varepsilon)\text{-WOT}^{\|n}\|\text{Comm})$$

for an  $n > 0$  such that  $\mathbf{F}$  is a  $(p', q', \varepsilon')$ -WOT with  $p' + q' + 2\varepsilon' \leq 0.24$ . Using Lemma 6.9, we need to find a value  $n$  and constants  $\alpha$  and  $\beta$  with  $\alpha + \beta \leq 0.24$ , such that  $e^{-n(1-p)} \leq \alpha$  and  $nq + 2n\varepsilon \leq \beta$ , which is equivalent to  $n(1-p) \geq \ln(1/\alpha)$  and  $q + 2\varepsilon \leq \beta/n$ . We can choose

$$n := \left\lceil \frac{\ln(1/\alpha)}{1-p} \right\rceil \leq \frac{\ln(1/\alpha)}{1-p} + 1 \leq \frac{\ln(1/\alpha) + 1}{1-p}.$$

The first inequality is satisfied by definition of  $n$ , and the second if

$$q + 2\varepsilon \leq \frac{\beta(1-p)}{\ln(1/\alpha) + 1},$$

which is equivalent to

$$\frac{\ln(1/\alpha) + 1}{\beta}(q + 2\varepsilon) + p \leq 1.$$

Choosing  $\alpha = 0.05$ , and  $\beta = 0.19$ , we get  $(\ln(1/\alpha) + 1)/\beta \leq 22$ . Our protocol needs  $n \leq 4/(1-p)$  instances.  $\square$

In the same way, we get

**Lemma 6.20.** *If  $22p + q + 44\varepsilon < 1$ , then  $(p', q', \varepsilon')$ -WOT with  $p' + q' + 2\varepsilon' \leq 0.24$  can efficiently be implemented using  $4/(1 - q)$  instances of  $(p, q, \varepsilon)$ -WOT, secure in the semi-honest model.*

The proof of Lemma 6.20 is omitted, as it can be done in the same way as the proof of Lemma 6.19.

**Lemma 6.21.** *If  $7\sqrt{p+q} + 2\varepsilon < 1$ , then  $(p', q', \varepsilon')$ -WOT with  $p' + q' + 2\varepsilon' \leq 0.24$  can efficiently be implemented using  $3(1/2 - \varepsilon)^{-2}$  instances of  $(p, q, \varepsilon)$ -WOT, secure in the semi-honest model.*

*Proof.* We apply

$$\mathbf{F} = \text{E-Reduce}((p, q, \varepsilon)\text{-WOT}^{\parallel n} \parallel \text{Comm})$$

for an  $n > 0$  such that  $\mathbf{F}$  is a  $(p', q', \varepsilon')$ -WOT with  $p' + q' + 2\varepsilon' \leq 0.24$ . Using Lemma 6.10, we need to find a value  $n$  and constants  $\alpha$  and  $\beta$  with  $2\alpha + \beta \leq 0.24$ , such that  $e^{-2n(1/2-\varepsilon)^2} \leq \alpha$  and  $np + nq \leq \beta$ , which is equivalent to  $2n(1/2 - \varepsilon)^2 \geq \ln(1/\alpha)$  and  $p + q \leq \beta/n$ . Furthermore, we need  $\varepsilon < \frac{1}{2}$ . We choose

$$n := \left\lceil \frac{\ln(1/\alpha)}{2(1/2 - \varepsilon)^2} \right\rceil \leq \frac{\ln(1/\alpha)}{2(1/2 - \varepsilon)^2} + 1 \leq \frac{\ln(1/\alpha) + 1/2}{2(1/2 - \varepsilon)^2}.$$

The last inequality follows from the fact that  $2(1/2 - \varepsilon)^2 \leq 1/2$ . The first inequality is satisfied by definition of  $n$ , and the second if

$$p + q \leq \frac{2\beta(1/2 - \varepsilon)^2}{\ln(1/\alpha) + 1/2},$$

which is equivalent to

$$\sqrt{\frac{2\ln(1/\alpha) + 1}{\beta}} \sqrt{p+q} + 2\varepsilon < 1.$$

Choosing  $\alpha = 0.02$  and  $\beta = 0.20$ , we get

$$\sqrt{\frac{2\ln(1/\alpha) + 1}{\beta}} \leq 7.$$

Our protocol needs  $n \leq 3(1/2 - \varepsilon)^{-2}$  instances. □

Theorem 6.4 summarizes all the partial results we obtained in this section.

**Theorem 6.4.** *Let  $p(k)$ ,  $q(k)$  and  $\varepsilon(k)$  be functions computable in time  $\text{poly}(k)$  such that*

$$p + q + 2\varepsilon \leq 0.24 ,$$

or

$$\min(p + 22q + 44\varepsilon, 22p + q + 44\varepsilon, 7\sqrt{p+q} + 2\varepsilon) < 1$$

for all  $k$ . Then  $(2^{-k}, 2^{-k}, 2^{-k})$ -WOT can efficiently be implemented using

$$O\left(\frac{k^{3.6}}{(1-p)(1-q)(1/2-\varepsilon)^2}\right)$$

instances of  $(p, q, \varepsilon)$ -WOT secure in the semi-honest model.

*Proof.* Follows directly from Lemmas 6.18, 6.19, 6.20, and 6.21. □

Since Theorem 6.2 gives us a bound on the number of instances used, we can also bound the error probability, and therefore, we can extend the result of Theorem 6.2 to allow for a (small) error.

**Corollary 6.2.** *Let  $p(k)$ ,  $q(k)$  and  $\varepsilon(k)$  be functions computable in time  $\text{poly}(k)$  such that*

$$(1 - p - q)^4 < -178 \cdot \log(1 - 2\varepsilon)$$

for all  $k$ . Then  $(2^{-k}, 2^{-k}, 2^{-k})$ -WOT can efficiently be implemented using

$$O\left(\frac{k^{3.6}}{(1-p-q)^4}\right)$$

instances of  $(p, q, \varepsilon)$ -WOT, secure in the semi-honest model.

*Proof.* We apply the reduction used in Theorem 6.2 for  $k = 5$ . We get  $p' \leq 2^{-5}$ ,  $q' \leq 2^{-5}$ , and  $\varepsilon' \leq (1 - (1 - 2\varepsilon)^n)/2$ , for  $n = 50 \cdot (1 - p - q)^{-4}$ . We have

$$\begin{aligned} \log(1 - 2\varepsilon') &= n \log(1 - 2\varepsilon) = 50 \cdot (1 - p - q)^{-4} \cdot (1 - p - q)^4 / -178 \\ &= -50/178 \end{aligned}$$

and therefore

$$p' + q' + 2\varepsilon' \leq 2 \cdot 2^{-5} + (1 - 2^{-50/178}) < 0.24 .$$

The statement follows now by applying Lemmas 6.17 and 6.18. □

## 6.7 Discussion and Open Problems

We have presented several protocols that implement ROT from many instances of WOT. For the special case where  $\varepsilon = 0$ , we were able to achieve the optimal bound, and when either  $p = 0$  or  $q = 0$ , we were at least able to give protocols which achieve the optimal bound for the basic protocols that we use.

However, for the general case, we still do not have very satisfactory results. One of the main difficulties is that we do not know exactly which of the basic protocols needs to be applied in which situation. To be able to do that, we would need a better understanding of how these protocols work together.

There are still many open problems concerning WOT amplification. Here are some of them:

- Can we improve the impossibility bound?
- For what parameters of WOT can we implement ROT with our basic protocols? How many instances do we need?
- Are there other basic protocols that give better bounds? Is it possible to use (a modified version of) the protocol **E-Reduce** from [DKS99]? Is it possible to reduce two parameters at the same time?
- Is there a (simple) way to make **E-Reduce** secure in the malicious model?
- Can **GWOT** be used to improve WOT amplification?
- Is it possible to define WOT in another, more general way?
- How do we have to define WOT in a multi-party setting?

## Chapter 7

# Computational Weak Oblivious Transfer

In this chapter we show how an OT which may contain errors and which is only *mildly computationally secure* for the two players can be amplified to a computationally-secure OT. In particular, we show in Theorem 7.2 — using Holenstein’s uniform hard-core lemma [Hol05, Hol06], which is a uniform variant of Impagliazzo’s hard-core lemma [Imp95] — that if WOT can be amplified to ROT in the information-theoretic setting, then also the corresponding computational version of WOT can be amplified to a computationally-secure ROT, *using the same protocol*.

Our results generalize the results presented in [Hai04], as we cover a much larger region for the values  $p$ ,  $q$  and  $\varepsilon$ , and in our case the security for both players may be computational.

## 7.1 Preliminaries

In the following,  $k \in \mathbb{N}$  is always the security parameter. We say that a function  $f : \mathbb{N} \rightarrow \mathbb{N}$  is *polynomial in  $k$* , denoted by  $\text{poly}(k)$ , if there exist constants  $c > 0$  and  $k_0$ , such that  $f(k) \leq k^c$  for all  $k \geq k_0$ . A function  $f : \mathbb{N} \rightarrow [0, 1]$  is *negligible in  $k$* , denoted by  $\text{negl}(k)$ , if for all constant  $c > 0$

there exists a constant  $k_0$ , such that  $f(k) \leq k^{-c}$  for all  $k \geq k_0$ . A function  $f : \mathbb{N} \rightarrow [0, 1]$  is *noticeable* if there exist constants  $c > 0$  and  $k_0$  such that  $f(k) \geq k^{-c}$  for all  $k \geq k_0$ . An algorithm  $B$  which has oracle access to an algorithm  $A$  will be denoted by  $B^A$ .

We will need the following lemmas, which are, when put together, the computational version of Lemma 2.6.

**Lemma 7.1.** *Let functions  $f : \{0, 1\}^k \rightarrow \{0, 1\}^\ell$ ,  $P : \{0, 1\}^k \rightarrow \{0, 1\}$ , and a distribution  $P_W$  over  $\{0, 1\}^k$  be given. There is an oracle algorithm  $B^{(\cdot)}$  such that, for any algorithm  $A$  where*

$$\Pr[A(f(W), P(W)) = 1] - \Pr[A(f(W), U) = 1] = \varepsilon ,$$

where  $W$  is distributed according to  $P_W$  and  $U$  is uniformly distributed, algorithm  $B^A$  satisfies

$$\Pr[B^A(f(W)) = P(W)] = \frac{1}{2} + \varepsilon ,$$

does one oracle call to  $A$ , and computes one XOR.

*Proof.* On input  $f(w)$ , let algorithm  $B^A$  choose a bit  $u$  uniformly at random and output  $A(f(w), u) \oplus u \oplus 1$ . Let

$$g(w, u) := \Pr[A(f(w), u) = 1] .$$

The output of  $B^A$  is correct either if  $U = P(W)$  and the output of  $A$  is 1, or  $U \neq P(W)$  and the output of  $A$  is 0. We get

$$\begin{aligned} & \Pr[B^A(f(W)) = P(W)] \\ &= \sum_w P_W(w) \left( \frac{g(w, P(w))}{2} + \frac{1 - g(w, 1 - P(w))}{2} \right) \\ &= \frac{1}{2} + \sum_w P_W(w) \frac{g(w, P(w)) - g(w, 1 - P(w))}{2} \\ &= \frac{1}{2} + \sum_w P_W(w) \left( g(w, P(w)) - \frac{g(w, P(w)) - g(w, 1 - P(w))}{2} \right) \\ &= \frac{1}{2} + \Pr[A(f(W), P(W)) = 1] - \Pr[A(f(W), U) = 1] \\ &= \frac{1}{2} + \text{Adv}^A(f(W), P(W)), (f(W), U) . \end{aligned}$$

□

**Lemma 7.2.** *Let functions  $f : \{0, 1\}^k \rightarrow \{0, 1\}^\ell$ ,  $P : \{0, 1\}^k \rightarrow \{0, 1\}$ , and a distribution  $P_W$  over  $\{0, 1\}^k$  be given. There is an oracle algorithm  $A^{(\cdot)}$  such that, for any algorithm  $B$  where*

$$\Pr[B(f(W)) = P(W)] = \frac{1}{2} + \varepsilon,$$

we have

$$\text{Adv}^{A^B}(f(W), P(W)), (f(W), U) = \varepsilon,$$

where  $W$  is distributed according to  $P_W$  and  $U$  is uniformly distributed, does one oracle call to  $A$ , and computes one XOR.

*Proof.* On input  $(f(w), b)$ , let Algorithm  $A$  output  $B(f(w)) \oplus b \oplus 1$ . If  $b$  is a uniform random bit, then we have  $\Pr[A^B(f(w), b) = 1] = 1/2$ , and if  $b = P(w)$ , then  $\Pr[A^B(f(w), b) = 1] = 1/2 + \varepsilon$ . Therefore, we have  $\text{Adv}^{A^B}((f(W), P(W)), (f(W), U)) = \varepsilon$ .  $\square$

## 7.2 Pseudo-Randomness Extraction

In this section we state a *pseudo-randomness extraction theorem*, Theorem 7.1, that we need later to prove our main theorem of this chapter, Theorem 7.2. Theorem 7.1 is based on the *uniform hard-core lemma* [Hol05, Hol06], which is a uniform variant of the hard-core lemma from [Imp95].

**Lemma 7.3** (Uniform hard-core lemma [Hol05, Hol06]). *Let the functions  $f : \{0, 1\}^k \rightarrow \{0, 1\}^\ell$ ,  $P : \{0, 1\}^k \rightarrow \{0, 1\}$ ,  $\delta : \mathbb{N} \rightarrow [0, 1]$  and  $\gamma : \mathbb{N} \rightarrow [0, 1]$  computable in time  $\text{poly}(k)$  be given, such that  $\gamma$  and  $\delta$  are noticeable. Assume that there is no polynomial time algorithm  $B$  such that*

$$\Pr[B(f(W)) = P(W)] \geq 1 - \frac{\delta}{2} + \frac{\gamma^2 \delta^5}{8192},$$

where  $W$  is chosen uniformly at random from  $\{0, 1\}^k$ , for infinitely many  $k$ . Then, there is no polynomial time oracle algorithm  $A^{(\cdot)}$ <sup>1</sup> such that for infinitely many  $k$  the following holds: For any set  $\mathcal{S} \subseteq \{0, 1\}^k$  with  $|\mathcal{S}| \geq \delta 2^k$ ,

$$\Pr[A^{\chi_{\mathcal{S}}}(f(W)) = P(W)] \geq \frac{1 + \gamma}{2},$$

---

<sup>1</sup> $A^{(\cdot)}$  has oracle access to the characteristic function  $\chi_{\mathcal{S}}$  of the set  $\mathcal{S}$ , which is defined as  $\chi_{\mathcal{S}}(w) := 1$  if  $w \in \mathcal{S}$  and  $\chi_{\mathcal{S}}(w) := 0$  otherwise.

where  $W$  is chosen uniformly at random from  $\mathcal{S}$  and the queries of  $A$  to  $\chi_{\mathcal{S}}$  are computed independently of the input  $f(W)$ .

Theorem 7.1 is a modified version of Theorem 7.3 in [Hol06] and differs from it in two points. First, we simplified it by omitting the function  $q(w)$  that indicates whether  $w$  is valid, because in our setting all  $w$  are valid. Second, we allow the functions  $\text{Ext}$  and  $\text{Leak}$  to depend on the value  $Z^n$ , and not only on  $X^n$ . The proof of Theorem 7.1 is basically the same as the proof of Theorem 7.3 in [Hol06]. Notice that in the proof of Theorem 7.3 in [Hol06] there is a step missing before equation (7.8), which is fixed in our proof.

The main difference of Theorem 7.3 in [Hol06] and our Theorem 7.1 compared to the (implicit) extraction lemma in [Hås90, HILL99] and the extraction lemma in [HHR06] is that it allows the adversary to gain some additional knowledge during the extraction, expressed by the function  $\text{Leak}$ .

**Theorem 7.1** (Pseudo-randomness extraction theorem, [Hol06]). *Let the functions  $f : \{0, 1\}^k \rightarrow \{0, 1\}^\ell$ ,  $P : \{0, 1\}^k \rightarrow \{0, 1\}$ , and  $\beta : \mathbb{N} \rightarrow [0, 1]$ , all computable in time  $\text{poly}(k)$ , be given, and let  $1 - \beta(k)$  be noticeable. Assume that every polynomial time algorithm  $B$  satisfies*

$$\Pr[B(f(W)) = P(W)] \leq \frac{1 + \beta(k)}{2}$$

for all but finitely many  $k$ , for a uniform random  $W \in \{0, 1\}^k$ . Further, let also functions  $n(k)$ ,  $s(k)$ ,

$$\begin{aligned} \text{Ext} : \{0, 1\}^{\ell \cdot n} \times \{0, 1\}^n \times \{0, 1\}^s &\rightarrow \{0, 1\}^t, \\ \text{Leak} : \{0, 1\}^{\ell \cdot n} \times \{0, 1\}^n \times \{0, 1\}^s &\rightarrow \{0, 1\}^{t'} \end{aligned}$$

be given which are computable in time  $\text{poly}(k)$ , and satisfy the following: For any distribution  $P_{XZ}$  over  $\{0, 1\} \times \{0, 1\}^\ell$  where  $\text{PredAdv}(X | Z) \leq \beta(k)$ ,  $\text{Ext}(Z^n, X^n, R)$  is  $\varepsilon(k)$ -close to uniform with respect to  $\text{Leak}(Z^n, X^n, R)$ , for  $R \in \{0, 1\}^s$  chosen uniformly at random. Then, no polynomial time algorithm  $A$ , which gets as input

$$\text{Leak}((f(W_0), \dots, f(W_{n-1})), (P(W_0), \dots, P(W_{n-1})), R),$$

(where  $(W_1, \dots, W_n)$  is chosen uniformly at random) distinguishes

$$\text{Ext}((f(W_0), \dots, f(W_{n-1})), (P(W_0), \dots, P(W_{n-1})), R)$$



from a uniform random string of length  $t$  with advantage  $\varepsilon(k) + \gamma(k)$ , for any non-negligible function  $\gamma(k)$ .

*Proof.* Let us assume there exists an algorithm  $A$  that contradicts our assumption. We will use  $A$  to construct an oracle algorithm  $\bar{A}^{\chi_S}$  for which the following holds for infinitely many  $k$  for a noticeable function  $\gamma'$ . For any set  $\mathcal{S} \subseteq \{0, 1\}^k$  with  $|\mathcal{S}| \geq (1 - \beta(k))2^k$ , we have

$$\Pr[\bar{A}^{\chi_S}(f(W)) = P(W)] \geq \frac{1 + \gamma'}{2},$$

where the probability is over the randomness of  $\bar{A}^{\chi_S}$ ,  $W$  is chosen uniformly at random from  $\{0, 1\}^k$ , and  $\bar{A}^{\chi_S}$  calls  $\chi_S$  only with queries which are computed independently of the input.

Since  $\gamma(k)$  is non-negligible, there exists a constant  $c$ , such that  $\gamma(k) \geq k^{-c}$  for infinitely many  $k$ . Let  $\gamma^*(k) := k^{-c}$ .  $\gamma^*(k)$  is a noticeable function with  $\gamma^*(k) \leq \gamma(k)$  for infinitely many  $k$ .

For any fixed  $j \in \{0, \dots, n\}$  and any fixed set  $\mathcal{S} \subseteq \{0, 1\}^k$  with  $|\mathcal{S}| \geq (1 - \beta)2^k$ , we define the following values. For all  $i \in \{0, \dots, n-1\}$ , we choose  $w_i \in \{0, 1\}^k$  and  $u_i \in \{0, 1\}$  uniformly at random. Then we compute

$$y_i := \begin{cases} P(w_i) & \text{if } i \geq j \text{ or } w_i \notin \mathcal{S}, \\ u_i & \text{otherwise,} \end{cases} \quad (7.1)$$

$$e_j := \text{Ext}((f(w_1), \dots, f(w_n)), y^n, r), \quad \text{and} \quad (7.2)$$

$$\ell_j := \text{Leak}((f(w_1), \dots, f(w_n)), y^n, r), \quad (7.3)$$

where  $r \in \{0, 1\}^s$  is chosen uniformly at random.

Let  $P_{E_j L_j}$  be the distribution of  $(e_j, \ell_j)$ . From our assumption follows that

$$\text{Adv}^A((E_0, L_0), (U, L_0)) \geq \varepsilon + \gamma^*$$

for infinitely many  $k$ , where  $U \in \{0, 1\}^t$  is chosen uniformly at random. On the other hand, for  $j = n$ , with probability  $1 - \beta$  (over the choice of  $w_i$ ) we have  $y_i = u_i$ , and therefore, by Lemma 2.8,  $\text{PredAdv}(Y_i | f(W_i)) \leq \beta$ . The information-theoretic requirement on the functions  $\text{Ext}$  and  $\text{Leak}$  imply that  $E_n$  is  $\varepsilon$ -close to uniform with respect to  $L_n$  and therefore

$$\text{Adv}^A((E_n, L_n), (U, L_n)) \leq \varepsilon.$$

The triangle inequality implies

$$\text{Adv}^A((E_0, L_0), (E_n, L_n)) + \text{Adv}^A((U, L_0), (U, L_n)) \geq \gamma^*$$

for infinitely many  $k$ . It follows that at least one of the four inequalities  $\Pr[A(E_0, L_0) = 1] - \Pr[A(E_n, L_n) = 1] \geq \gamma^*/2$ ,  $\Pr[A(E_n, L_n) = 1] - \Pr[A(E_0, L_0) = 1] \geq \gamma^*/2$ ,  $\Pr[A(U, L_0) = 1] - \Pr[A(U, L_n) = 1] \geq \gamma^*/2$ , or  $\Pr[A(U, L_n) = 1] - \Pr[A(U, L_0) = 1] \geq \gamma^*/2$  holds for infinitely many  $k$ , from which follows that there exists an algorithm  $A'$  such that

$$\Pr[A'(E_0, L_0) = 1] - \Pr[A'(E_n, L_n) = 1] \geq \frac{\gamma^*}{2}$$

for infinitely many  $k$ . For a  $J \in \{0, \dots, n-1\}$  chosen uniformly at random, we have

$$\Pr[A'(E_J, L_J) = 1] - \Pr[A'(E_{J+1}, L_{J+1}) = 1] \geq \frac{\gamma^*}{2n}$$

for infinitely many  $k$ . We can now give an implementation of a distinguisher which distinguishes  $(f(W), P(W))$  from  $(f(W), U)$  with advantage  $\gamma^*/(2n)$  for infinitely many  $k$ , if  $W$  is chosen uniformly from  $\mathcal{S}$  and  $U$  is a uniform random bit, as long as oracle access to  $\chi_{\mathcal{S}}$  is given. Let  $(f(w), b)$  be the input to the distinguisher. It chooses  $j \in \{0, \dots, n-1\}$ , and for all  $i \in \{0, \dots, n-1\}$  the values  $w_i \in \{0, 1\}^k$  and  $u_i \in \{0, 1\}$  uniformly at random. Then, for all  $i \in \{0, \dots, n-1\}$ , it computes the values  $f(w_i)$ ,  $P(w_i)$  and  $y_i$  as in (7.1). If  $w_j \in \mathcal{S}$ , it replaces  $f(w_j)$  with  $f(w)$  and  $y_j$  with  $b$ . Then, it computes  $e_j$  and  $\ell_j$  as in (7.2) and (7.3). If  $b$  is a uniform bit, then this process gives random variables  $(E_j, L_j)$  distributed according to  $P_{E_{j+1}L_{j+1}}$ , otherwise it gives random variables distributed according to  $P_{E_jL_j}$ . Therefore,  $A'$  distinguishes  $(f(W), P(W))$  from  $(f(W), U)$  with advantage  $\gamma^*/(2n)$  for infinitely many  $k$ , if  $W$  is chosen uniformly at random from  $\mathcal{S}$ . From Lemma 7.1 follows that there exists a polynomial time algorithm that predicts  $P(W)$  from  $f(W)$ , where  $W$  is chosen uniformly at random from  $\mathcal{S}$ , with probability at least  $1/2 + \gamma^*/(2n)$  for infinitely many  $k$ . We can now apply Lemma 7.3 for  $\gamma := \gamma^*/n$  and  $\delta := 1 - \beta$  to obtain the statement.  $\square$

### 7.3 Definition of Computational WOT

In order to define security in the computational setting, i.e., where the running time of the adversary is bounded by a polynomial, we need to

introduce a security parameter  $k$  on which the players agree beforehand. We consider the *uniform* model, that is, we require the same protocols to run on all security parameters, which they get as a separate input. Additionally, we require the security parameter to be larger than the sum of the length of all the inputs and outputs of the protocol. The security in the *computational semi-honest model* is very similar to the (information-theoretic) semi-honest model (Definition 3.3). The only differences are that we require the distinguishers to be efficient, i.e., to run in time  $\text{poly}(k)$ , and we require the advantage of these distinguishers to be negligible in  $k$ . Furthermore, we require that the simulator is efficient, i.e., runs in time  $\text{poly}(k)$ .

We say that  $X(k)$  and  $Y(k)$  are *computationally indistinguishable*, denoted by  $X \stackrel{c}{\equiv} Y$ , if  $\text{Adv}^{\mathcal{D}}(X, Y) \leq \text{negl}(k)$ , where  $\mathcal{D}$  is the set of all distinguishers that run in time  $\text{poly}(k)$ .

**Definition 7.1.** A protocol  $\mathbf{P}(\mathbf{F}) = (\mathbf{P}_A \parallel \mathbf{P}_B)(\mathbf{F})$  *securely implements*  $\mathbf{G}$  in the *computational semi-honest model*, if

- (Correctness)  $\mathbf{P}(\mathbf{F}_\emptyset) \stackrel{c}{\equiv} \mathbf{G}_\emptyset$ .
- (Security for A) There exists a system  $\mathbf{S}_B$  (called *the simulator for B*), that runs in time  $\text{poly}(k)$  and only modifies the auxiliary interfaces, such that

$$(\mathbf{P}_A \parallel \underline{\mathbf{P}}_B)(\mathbf{F}_{\{\widehat{B}\}}) \stackrel{c}{\equiv} \mathbf{S}_B(\mathbf{G}_{\{\widehat{B}\}}).$$

- (Security for B) There exists a system  $\mathbf{S}_A$  (called *the simulator for A*), that runs in time  $\text{poly}(k)$  and only modifies the auxiliary interfaces, such that

$$(\underline{\mathbf{P}}_A \parallel \mathbf{P}_B)(\mathbf{F}_{\{\widehat{A}\}}) \stackrel{c}{\equiv} \mathbf{S}_A(\mathbf{G}_{\{\widehat{A}\}}).$$

The primitive  $(p, q, \varepsilon)$ -compWOT denotes the computational version of  $(p, q, \varepsilon)$ -WOT. The difference to the definition of WOT is that we require the algorithm that guesses  $X_{1-C}$  or  $C$  to be efficient.

**Definition 7.2** (Computational WOT, semi-honest model). Let functions  $\varepsilon : \mathbb{N} \rightarrow [0, 1/2]$ ,  $p : \mathbb{N} \rightarrow [0, 1]$ , and  $q : \mathbb{N} \rightarrow [0, 1]$  computable in time  $\text{poly}(k)$  be given. Let  $\mathbf{F} = (\mathbf{F}_\emptyset, \mathbf{F}_{\{\widehat{A}\}}, \mathbf{F}_{\{\widehat{B}\}})$  be a collection of systems in the computational semi-honest model. On input  $k$ ,  $\mathbf{F}$  outputs  $(X_0, X_1)$  to A and  $(C, Y)$  to B. Let  $U$  be the auxiliary output to A by  $\mathbf{F}_{\{\widehat{A}\}}$  and  $V$

be the auxiliary output to **B** by  $\mathbf{F}_{\{\widehat{\mathbf{B}}\}}$ . Let  $E := X_C \oplus Y$ .  $\mathbf{F}$  implements  $(p(k), q(k), \varepsilon(k))$ -compWOT in the computational semi-honest model, if

- (Efficiency)  $\mathbf{F}$  can be executed in time  $\text{poly}(k)$ .
- (Correctness)  $\Pr[E = 1] \leq \varepsilon(k)$  for all  $k$ .
- (Security for **A**) All polynomial time algorithms  $A$  satisfy

$$\Pr[A(V, E) = X_{1-C}] \leq \frac{1 + q(k)}{2}$$

for all but finitely many  $k$ .

- (Security for **B**) All polynomial time algorithms  $A$  satisfy

$$\Pr[A(U, E) = C] \leq \frac{1 + p(k)}{2}$$

for all but finitely many  $k$ .

Lemma 7.4 is the computational version of Lemma 6.2.

**Lemma 7.4.** *A collection of systems  $\mathbf{F}$  that securely implements*

$$(\text{negl}(k), \text{negl}(k), \text{negl}(k))\text{-compWOT}$$

*also securely implements  $\binom{2}{1}$ -ROT<sup>1</sup> in the computational semi-honest model.*

*Proof.* From the (computational) security conditions for **A** follows that  $C$  is (statistically)  $\text{negl}(k)$ -close to uniform with respect to  $(X_0, X_1)$ . Otherwise, it could easily and efficiently be distinguished from uniform. Similarly, it follows from the security condition for **B** that  $X_{1-C}$  is  $\text{negl}(k)$ -close to uniform with respect to  $(C, X_C)$ . From Lemma 6.1 follows that  $(C, X_0, X_1)$  is  $\text{negl}(k)$ -close to uniform. Together with the correctness condition, we get

$$\mathbf{F}_{\emptyset} \equiv_{\text{negl}(k)} \text{ROT}_{\emptyset}.$$

Let  $\mathbf{F}_{\{\mathbf{B}\}}$  produce the output distribution  $P_{X_0 X_1 C Y V}$ , and let  $P_{\overline{X_0 X_1 C Y}}$  be the output distribution of ROT. We define  $\mathbf{S}_{\mathbf{B}}$  as follows. After receiving  $(c, y)$  from ROT, it simulates  $\mathbf{F}_{\{\mathbf{B}\}}$ , which outputs  $(c', y', v')$ , until  $c' = b$  and  $y' = y$ . It outputs  $v'$ .

From the correctness condition follows that  $(C', Y')$  is  $\text{negl}(k)$ -close to uniform, and, therefore, the probability  $C' = c$  and  $Y' = y$  is at least  $1/4 - \text{negl}(k)$ . The expected number of iterations<sup>2</sup> is therefore constant and the simulator is efficient since the system  $\mathbf{F}$  is efficient.

Let us assume that there exists an algorithm  $A$  with

$$\text{Adv}^A(X_0 X_1 C Y V, \overline{X_0 X_1 C Y V'}) \geq \gamma(k),$$

for a non-negligible function  $\gamma(k)$ . There exists a constant  $c$ , such that  $\gamma(k) \geq k^{-c}$  for infinitely many  $k$ . Let  $\gamma^*(k) := k^{-c}$ .  $\gamma^*(k)$  is a noticeable function with  $\gamma^*(k) \leq \gamma(k)$  for infinitely many  $k$ .

Since  $(C, X_C, Y, V)$  is  $\text{negl}(k)$ -close to  $(\overline{C}, \overline{X_C}, \overline{Y}, V')$ , and  $\overline{X_{1-\overline{C}}}$  is uniform with respect to  $(\overline{C}, \overline{X_C}, \overline{Y}, V')$ , we have

$$\text{Adv}^A(RC X_C Y V, \overline{X_{1-\overline{C}}} \overline{C X_C Y V'}) \leq \text{negl}(k),$$

where  $R$  is chosen uniformly at random. It follows that

$$\text{Adv}^A(RC X_C Y V, X_{1-C} C X_C Y V) \geq \gamma^*(k) - \text{negl}(k)$$

for infinitely many  $k$ , and therefore either

$$\Pr[A(RC X_C Y V) = 1] - \Pr[A(X_{1-C} C X_C Y V) = 1] \geq \gamma^*(k) - \text{negl}(k)$$

for infinitely many  $k$ , or

$$\Pr[A(X_{1-C} C X_C Y V) = 1] - \Pr[A(RC X_C Y V) = 1] \geq \gamma^*(k) - \text{negl}(k)$$

for infinitely many  $k$ . Note that  $(C, Y)$  is a function of  $V$  and  $E = X_C \oplus Y$ . In both cases, it follows from Lemma 7.1 that there exists an algorithm that can predict  $X_{1-C}$  with probability  $1/2 + \gamma^*(k) - \text{negl}(k)$  for infinitely many  $k$ , which contradicts our assumption that no such algorithm exists.

The proof for the security of  $\mathbf{B}$  can be done the same way.  $\square$

## 7.4 Computational-WOT Amplification

In [Hol05], Lemma 7.3 was used to show that any information-theoretic key-agreement protocol can also be used in the computational setting.

<sup>2</sup>If we want the algorithm to be worst-case polynomial, we simply abort after a polynomial amount of simulations.

We will use a very similar proof to show that any protocol that efficiently implements ROT out of many instances of WOT in the semi-honest model can be used to implement ROT out of many instances of compWOT in the computational semi-honest model.

**Theorem 7.2.** *Let the functions  $\varepsilon(k)$ ,  $p(k)$ ,  $q(k)$  and  $n(k)$  computable in time  $\text{poly}(k)$  be given. Let a protocol  $\mathbf{P}(\text{Comm})$  achieve  $(p, q, \varepsilon)$ -compWOT. Further, let an efficient protocol  $\mathbf{Q}((p, q, \varepsilon)\text{-WOT}^{\parallel n} \parallel \text{Comm})$  be given which takes  $k$  as input and securely implements  $(\text{negl}(k), \text{negl}(k), \text{negl}(k))$ -WOT in the semi-honest model. Then the protocol<sup>3</sup>  $\mathbf{Q}(\mathbf{P}(\text{Comm})^{\parallel n} \parallel \text{Comm})$  implements  $(\text{negl}(k), \text{negl}(k), \text{negl}(k))$ -compWOT in the computational semi-honest model.*

*Proof.* Let  $W = (W_A, W_B)$  be the randomness used in  $\mathbf{P}(\text{Comm})$  by the sender and the receiver, and let  $Z$  be the communication. The honest protocols  $\mathbf{P}_A$  and  $\mathbf{P}_B$  output  $(X_0, X_1)$  and  $(C, Y)$ , respectively, while the semi-honest protocols  $\underline{\mathbf{P}}_A$  and  $\underline{\mathbf{P}}_B$  additionally have the auxiliary outputs  $U = (X_0, X_1, Z, W_A)$  and  $V = (C, Y, Z, W_B)$ , respectively. Let  $E := Y \oplus X_C$ . All these values are functions of  $W$ .

$\mathbf{Q}_A$  receives  $(X_0^n, X_1^n)$  from  $\mathbf{P}(\text{Comm})^{\parallel n}$  and outputs  $(X_0^*, X_1^*)$ .  $\mathbf{Q}_B$  receives  $(C^n, Y^n)$  from  $\mathbf{P}(\text{Comm})^{\parallel n}$  and outputs  $(C^*, Y^*)$ . Let  $R = (R_A, R_B)$  be the randomness used in  $\mathbf{Q}$  by both players, and let  $Z'$  be the communication sent over  $\text{Comm}$  in  $\mathbf{Q}$ . Let  $E^* := Y^* \oplus X_{C^*}^*$ . The values  $E^*$ ,  $X_0^*$ ,  $X_1^*$ ,  $C^*$ ,  $Y^*$  and  $Z'$  are functions of  $(X_0^n, X_1^n, C^n, Y^n, R)$ .

First of all, the resulting protocol  $\mathbf{Q}(\mathbf{P}(\text{Comm})^{\parallel n} \parallel \text{Comm})$  will be correct and efficient, as every outcome of  $\mathbf{P}(\text{Comm})$  satisfies  $\Pr[Y \neq X_C] \leq \varepsilon$ .

For the security for  $A$ , we define the following functions: let  $f(W) := (V, E)$  and  $P(W) := X_{1-C}$ . Since  $X_C = E \oplus Y$ , it is possible to simulate the protocol  $\mathbf{Q}$  using the values  $(V, E)^n$ ,  $(X_{1-C})^n$ , and  $R$ . Therefore, we can define

$$\text{Ext}((V, E)^n, (X_{1-C})^n, R) := X_{1-C}^*$$

and

$$\text{Leak}((V, E)^n, (X_{1-C})^n, R) := (E^*, C^*, Y^*, V^n, Z', R_B).$$

$\mathbf{Q}$  implements  $(\text{negl}(k), \text{negl}(k), \text{negl}(k))$ -WOT. It follows from Lemma 7.2 that the functions  $\text{Ext}$  and  $\text{Leak}$  satisfy the extraction requirements from

<sup>3</sup>This is an execution of  $\mathbf{Q}$ , where all calls to WOT are replaced by independent executions of  $\mathbf{P}$ .

Theorem 7.1 with  $\varepsilon(k) = \text{negl}(k)$ . Furthermore, Ext and Leak can be computed efficiently, since the protocol **Q** is efficient. From the security condition of compWOT follows that every polynomial-time algorithm  $B$  satisfies

$$\Pr[B(f(W)) = P(W)] = \Pr[B(V, E) = X_{1-C}] \leq \frac{1 + q(k)}{2}$$

for all but finitely many  $k$ , for  $W$  chosen uniformly at random. Theorem 7.1 tells us that no polynomial time algorithm  $A$ , which gets as input  $\text{Leak}((V, E)^n, (X_{1-C})^n, R)$  distinguishes  $\text{Ext}((V, E)^n, (X_{1-C})^n, R)$  from a uniform random bit with advantage  $\text{negl}(k) + \gamma(k)$ , for any non-negligible function  $\gamma(k)$ . The security for **A** follows now from Lemma 7.2.

For the security for **B**, we define the following functions: let  $f(W) := (U, E)$  and  $P(W) := C$ . Since  $X_C = E \oplus Y$ , it is possible to simulate the protocol **Q** using the values  $(U, E)^n, C^n$ , and  $R$ . Therefore, we can define

$$\text{Ext}((U, E)^n, C^n, R) := C^*,$$

and

$$\text{Leak}((U, E)^n, C^n, R) := (E^*, X_0^*, X_1^*, U^n, Z', R_A).$$

**Q** implements  $(\text{negl}(k), \text{negl}(k), \text{negl}(k))$ -WOT. It follows from Lemma 7.2 that the functions Ext and Leak satisfy the extraction requirements from Theorem 7.1 with  $\varepsilon(k) = \text{negl}(k)$ . Furthermore, Ext and Leak can be computed efficiently, since the protocol **Q** is efficient. From the security condition of compWOT follows that every polynomial time algorithm  $A$  satisfies

$$\Pr[A(f(W)) = P(W)] = \Pr[A(U, E) = C] \leq \frac{1 + p(k)}{2}$$

for all but finitely many  $k$ , for  $W$  chosen uniformly at random. Theorem 7.1 tells us that no polynomial time algorithm  $B$ , which gets as input  $\text{Leak}((U, E)^n, C^n, R)$  distinguishes  $\text{Ext}((U, E)^n, C^n, R)$  from a uniform random bit with advantage  $\text{negl}(k) + \gamma(k)$ , for any non-negligible function  $\gamma(k)$ . The security for **B** follows now from Lemma 7.2.  $\square$

Together with the information-theoretic reductions presented in Chapters 4 and 6, we get a protocol that securely amplifies  $(p, q, \varepsilon)$ -compWOT to  $\binom{1}{2}$ -OT<sup>1</sup> in the computational semi-honest model.

**Corollary 7.1.** *Let the functions  $\varepsilon(k)$ ,  $p(k)$ , and  $q(k)$ , computable in time  $\text{poly}(k)$ , be given, where either for all  $k$*

$$\varepsilon = 0 \wedge p + q < 1 - 1/\text{poly}(k) ,$$

$$p + q + 2\varepsilon \leq 0.24 ,$$

or

$$\min(p + 22q + 44\varepsilon, 22p + q + 44\varepsilon, 7\sqrt{p+q} + 2\varepsilon) < 1 - 1/\text{poly}(k) ,$$

or, for constant functions  $p(k)$ ,  $q(k)$  and  $\varepsilon(k)$ ,

$$p = 0 \wedge \sqrt{q} + 2\varepsilon < 1 ,$$

$$q = 0 \wedge \sqrt{p} + 2\varepsilon < 1 ,$$

or

$$(1 - p - q)^4 < -178 \cdot \log(1 - 2\varepsilon) .$$

If there exists a protocol  $\mathbf{P}(\text{Comm})$  that securely implements  $(p, q, \varepsilon)$ -*compWOT* in the computational semi-honest model, then there exists a protocol  $\mathbf{Q}(\text{Comm})$  that implements  $\left(\frac{1}{2}\right)$ -*OT*<sup>1</sup> in the computational semi-honest model.

## 7.5 Discussion and Open Problems

We have shown that Holenstein's hard-core lemma [Hol05, Hol06] can also be applied in the setting of two-party computation, and presented a new computational assumption, namely *computational weak oblivious transfer*, under which oblivious transfer and hence any two-party computation is possible in a computationally secure way.

The *pseudo-randomness extraction theorem* presented in [Hol06] turned out not to be general enough for our application. It would be interesting to know whether our generalization is also useful in other applications.

A very interesting open problem is whether our results can be used to improve the results from [Hai04], i.e., whether it is possible to implement computationally-secure OT from weaker requirements on trapdoor permutations.



# Bibliography

- [AC93] R. Ahlswede and I. Csiszár. Common randomness in information theory and cryptography – part I: Secret sharing. *IEEE Transactions on Information Theory*, 39(4):1121–1132, 1993.
- [AIR01] W. Aiello, Y. Ishai, and O. Reingold. Priced oblivious transfer: How to sell digital goods. In *Advances in Cryptology — EUROCRYPT '01*, Lecture Notes in Computer Science, pages 119–135. Springer-Verlag, 2001.
- [BBCM95] C. H. Bennett, G. Brassard, C. Crépeau, and U. Maurer. Generalized privacy amplification. *IEEE Transactions on Information Theory*, 41, 1995.
- [BBCS92] C. H. Bennett, G. Brassard, C. Crépeau, and H. Skubiszewska. Practical quantum oblivious transfer. In *Advances in Cryptology — CRYPTO '91*, volume 576 of *Lecture Notes in Computer Science*, pages 351–366. Springer, 1992.
- [BBR88] C. H. Bennett, G. Brassard, and J.-M. Robert. Privacy amplification by public discussion. *SIAM Journal on Computing*, 17(2):210–229, 1988.
- [BC97] G. Brassard and C. Crépeau. Oblivious transfers and privacy amplification. In *Advances in Cryptology — EUROCRYPT '97*, volume 1233 of *Lecture Notes in Computer Science*, pages 334–347. Springer-Verlag, 1997.
- [BCR86] G. Brassard, C. Crépeau, and J.-M. Robert. Information theoretic reductions among disclosure problems. In *Proceed-*

- ings of the 27th Annual IEEE Symposium on Foundations of Computer Science (FOCS '86)*, pages 168–173, 1986.
- [BCS96] G. Brassard, C. Crépeau, and M. Sántha. Oblivious transfers and intersecting codes. *IEEE Transactions on Information Theory, special issue on coding and complexity*, 42(6):1769–1780, 1996.
- [BCW03] G. Brassard, C. Crépeau, and S. Wolf. Oblivious transfers and privacy amplification. *Journal of Cryptology*, 16(4):219–237, 2003.
- [Bea89] D. Beaver. Multiparty protocols tolerating half faulty processors. In *Advances in Cryptology — CRYPTO '89*, volume 435 of *Lecture Notes in Computer Science*, pages 560–572. Springer-Verlag, 1989.
- [Bea92] D. Beaver. Foundations of secure interactive computing. In *Advances in Cryptology — CRYPTO '91*, volume 1233 of *Lecture Notes in Computer Science*, pages 377–391. Springer-Verlag, 1992.
- [Bea95] D. Beaver. Precomputing oblivious transfer. In *Advances in Cryptology — EUROCRYPT '95*, volume 963 of *Lecture Notes in Computer Science*, pages 97–109. Springer-Verlag, 1995.
- [BGW88] M. Ben-Or, S. Goldwasser, and A. Wigderson. Completeness theorems for non-cryptographic fault-tolerant distributed computation. In *Proceedings of the 21st Annual ACM Symposium on Theory of Computing (STOC '88)*, pages 1–10. ACM Press, 1988.
- [BM90] M. Bellare and S. Micali. Non-interactive oblivious transfer and applications. In *Advances in Cryptology — CRYPTO '89*, volume 435 of *Lecture Notes in Computer Science*. Springer-Verlag, 1990.
- [BPW03] M. Backes, B. Pfitzmann, and M. Waidner. A universally composable cryptographic library. <http://eprint.iacr.org/2003/015>, 2003.
- [Cac98] C. Cachin. On the foundations of oblivious transfer. In *Advances in Cryptology — EUROCRYPT '98*, volume 1403 of

- Lecture Notes in Computer Science*, pages 361–374. Springer-Verlag, 1998.
- [Can96] R. Canetti. *Studies in Secure Multiparty Computation and Applications*. PhD thesis, Weizmann Institute of Science, Israel, 1996.
- [Can00] R. Canetti. Security and composition of multiparty cryptographic protocols. *Journal of Cryptology*, 13(1):143–202, 2000.
- [Can01] R. Canetti. Universally composable security: A new paradigm for cryptographic protocols. In *Proceedings of the 42th Annual IEEE Symposium on Foundations of Computer Science (FOCS '01)*, pages 136–145, 2001. Updated Version at <http://eprint.iacr.org/2000/067>.
- [CCD88] D. Chaum, C. Crépeau, and I. Damgård. Multiparty unconditionally secure protocols (extended abstract). In *Proceedings of the 21st Annual ACM Symposium on Theory of Computing (STOC '88)*, pages 11–19. ACM Press, 1988.
- [CDvdG88] D. Chaum, I. Damgård, and J. van de Graaf. Multiparty computations ensuring privacy of each party's input and correctness of the result. In *Advances in Cryptology — CRYPTO '87*, volume 293 of *Lecture Notes in Computer Science*, pages 87–119. Springer-Verlag, 1988.
- [CF01] R. Canetti and M. Fischlin. Universally composable commitments. In *Advances in Cryptology — CRYPTO '01*, volume 576 of *Lecture Notes in Computer Science*, pages 19–40. Springer-Verlag, 2001.
- [Che52] H. Chernoff. A measure of asymptotic efficiency for tests of a hypothesis based on the sum of observations. *Annals of Mathematical Statistics*, 23:493–507, 1952.
- [CK88] C. Crépeau and J. Kilian. Achieving oblivious transfer using weakened security assumptions (extended abstract). In *Proceedings of the 29th Annual IEEE Symposium on Foundations of Computer Science (FOCS '88)*, pages 42–52, 1988.
- [CLOS02] R. Canetti, Y. Lindell, R. Ostrovsky, and A. Sahai. Universally composable two-party and multi-party secure

- computation. In *Proceedings of the 34th Annual ACM Symposium on Theory of Computing (STOC '02)*, pages 494–503. ACM Press, 2002. Full version available at <http://eprint.iacr.org/2002/140>.
- [CMW04] C. Crépeau, K. Morozov, and S. Wolf. Efficient unconditional oblivious transfer from almost any noisy channel. In *Proceedings of Fourth Conference on Security in Communication Networks (SCN)*, volume 3352 of *Lecture Notes in Computer Science*, pages 47–59. Springer-Verlag, 2004.
- [Cré88] C. Crépeau. Equivalence between two flavours of oblivious transfers (abstract). In *Advances in Cryptology — CRYPTO '87*, volume 293 of *Lecture Notes in Computer Science*, pages 350–354. Springer-Verlag, 1988.
- [Cré90] C. Crépeau. Verifiable disclosure of secrets and applications. In *Advances in Cryptology — CRYPTO '89*, volume 434 of *Lecture Notes in Computer Science*, pages 181–191. Springer-Verlag, 1990.
- [Cré97] C. Crépeau. Efficient cryptographic protocols based on noisy channels. In *Advances in Cryptology — CRYPTO '97*, volume 1233 of *Lecture Notes in Computer Science*, pages 306–317. Springer-Verlag, 1997.
- [CS91] C. Crépeau and M. Sántha. On the reversibility of oblivious transfer. In *Advances in Cryptology — EUROCRYPT '91*, volume 547 of *Lecture Notes in Computer Science*, pages 106–113. Springer, 1991.
- [CS06] C. Crépeau and G. Savvides. Optimal reductions between oblivious transfers using interactive hashing. In *Advances in Cryptology — EUROCRYPT '06*, volume 4004 of *Lecture Notes in Computer Science*, pages 201–221. Springer-Verlag, 2006.
- [CSSW06] C. Crépeau, G. Savvides, C. Schaffner, and J. Wullschlegler. Information-theoretic conditions for two-party secure function evaluation. In *Advances in Cryptology — EUROCRYPT '06*, volume 4004 of *Lecture Notes in Computer Science*, pages 538–554. Springer-Verlag, 2006. Full version available at <http://eprint.iacr.org/2006/183>.

- [CvdGT95] C. Crépeau, J. van de Graaf, and A. Tapp. Committed oblivious transfer and private multi-party computation. In *Advances in Cryptology — CRYPTO '95*, Lecture Notes in Computer Science, pages 110–123. Springer-Verlag, 1995.
- [CW79] J. L. Carter and M. N. Wegman. Universal classes of hash functions. *Journal of Computer and System Sciences*, 18:143–154, 1979.
- [DFMS04] I. Damgård, S. Fehr, K. Morozov, and L. Salvail. Unfair noisy channels and oblivious transfer. In *Theory of Cryptography Conference — TCC '04*, volume 2951 of *Lecture Notes in Computer Science*, pages 355–373. Springer-Verlag, 2004.
- [DFR<sup>+</sup>06] I. Damgård, S. Fehr, R. Renner, L. Salvail, and C. Schaffner. A tight high-order entropic uncertainty relation with applications in the bounded quantum-storage model. In preparation, 2006.
- [DFSS06] I. Damgård, S. Fehr, L. Salvail, and C. Schaffner. Oblivious transfer and linear functions. In *Advances in Cryptology — CRYPTO '06*, volume 4117 of *Lecture Notes in Computer Science*. Springer-Verlag, 2006.
- [DKS99] I. Damgård, J. Kilian, and L. Salvail. On the (im)possibility of basing oblivious transfer and bit commitment on weakened security assumptions. In *Advances in Cryptology — EUROCRYPT '99*, volume 1592 of *Lecture Notes in Computer Science*, pages 56–73. Springer-Verlag, 1999.
- [DM99] Y. Dodis and S. Micali. Lower bounds for oblivious transfer reductions. In *Advances in Cryptology — EUROCRYPT '99*, volume 1592 of *Lecture Notes in Computer Science*, pages 42–55. Springer-Verlag, 1999.
- [EGL85] S. Even, O. Goldreich, and A. Lempel. A randomized protocol for signing contracts. *Commun. ACM*, 28(6):637–647, 1985.
- [Fis06] M. Fischlin. Universally composable oblivious transfer in the multi-party setting. In *RSA Security Cryptographer's Track 2006*, volume 3860 of *Lecture Notes in Computer Science*, pages 332–349. Springer-Verlag, 2006.

- [GL91] S. Goldwasser and L. A. Levin. Fair computation of general functions in presence of immoral majority. In *Advances in Cryptology — CRYPTO '90*, Lecture Notes in Computer Science, pages 77–93. Springer-Verlag, 1991.
- [GMR85] S. Goldwasser, S. Micali, and C. Rackoff. The knowledge complexity of interactive proof-systems. In *Proceedings of the 17th Annual ACM Symposium on Theory of Computing (STOC '85)*, pages 291–304. ACM Press, 1985.
- [GMW87] O. Goldreich, S. Micali, and A. Wigderson. How to play any mental game. In *Proceedings of the 21st Annual ACM Symposium on Theory of Computing (STOC '87)*, pages 218–229. ACM Press, 1987.
- [GMY04] J. Garay, P. MacKenzie, and K. Yang. Efficient and universally composable committed oblivious transfer and applications. In *Theory of Cryptography Conference — TCC '04*, volume 2951 of *Lecture Notes in Computer Science*, pages 297–316. Springer-Verlag, 2004.
- [Gol04] O. Goldreich. *Foundations of Cryptography*, volume II: Basic Applications. Cambridge University Press, 2004.
- [GV88] O. Goldreich and R. Vainish. How to solve any protocol problem - an efficiency improvement. In *Advances in Cryptology — CRYPTO '87*, Lecture Notes in Computer Science, pages 73–86. Springer-Verlag, 1988.
- [Hai04] I. Haitner. Implementing oblivious transfer using collection of dense trapdoor permutations. In *Theory of Cryptography Conference — TCC '04*, volume 2951 of *Lecture Notes in Computer Science*, pages 394–409. Springer-Verlag, 2004.
- [Hås90] J. Håstad. Pseudo-random generators under uniform assumptions. In *Proceedings of the 22st Annual ACM Symposium on Theory of Computing (STOC '90)*, pages 395–404. ACM Press, 1990.
- [HHR06] I. Haitner, D. Harnik, and O. Reingold. On the power of the randomized iterate. In *Advances in Cryptology — CRYPTO '06*, volume 4117 of *Lecture Notes in Computer Science*, pages 21–40. Springer-Verlag, 2006.

- [HILL99] J. Håstad, R. Impagliazzo, L. A. Levin, and M. Luby. A pseudorandom generator from any one-way function. *SIAM J. Comput.*, 28(4):1364–1396, 1999.
- [HKN<sup>+</sup>05] D. Harnik, J. Kilian, M. Naor, O. Reingold, and A. Rosen. On robust combiners for oblivious transfer and other primitives. In *Advances in Cryptology — EUROCRYPT '05*, volume 3494 of *Lecture Notes in Computer Science*, pages 96–113, 2005.
- [Hoe63] W. Hoeffding. Probability inequalities for sums of bounded random variables. *Journal of the American Statistical Association*, 58(301):13–30, 1963.
- [Hol05] T. Holenstein. Key agreement from weak bit agreement. In *Proceedings of the 37th ACM Symposium on Theory of Computing (STOC '05)*, pages 664–673. ACM Press, 2005.
- [Hol06] T. Holenstein. *Strengthening key agreement using hard-core sets*. PhD thesis, ETH Zurich, Switzerland, 2006. Reprint as vol. 7 of *ETH Series in Information Security and Cryptography*, Hartung-Gorre Verlag.
- [HR05] T. Holenstein and R. Renner. One-way secret-key agreement and applications to circuit polarization and immunization of public-key encryption. In *Advances in Cryptology — CRYPTO '05*, volume 3621 of *Lecture Notes in Computer Science*, pages 478–493. Springer-Verlag, 2005.
- [ILL89] R. Impagliazzo, L. A. Levin, and M. Luby. Pseudorandom generation from one-way functions. In *Proceedings of the 21st Annual ACM Symposium on Theory of Computing (STOC '89)*, pages 12–24. ACM Press, 1989.
- [IMN06] H. Imai, K. Morozov, and A. Nascimento. On the oblivious transfer capacity of the erasure channel. In *Proceedings of 2006 IEEE International Symposium on Information Theory (ISIT '06)*, pages 1428–1431, 2006.
- [Imp95] R. Impagliazzo. Hard-core distributions for somewhat hard problems. In *Proceedings of the 36th Annual IEEE Symposium on Foundations of Computer Science (FOCS '95)*, pages 538–545. IEEE Computer Society, 1995.

- [IMQNW04] H. Imai, J. Müller-Quade, A. Nascimento, and A. Winter. Rates for bit commitment and coin tossing from noisy correlation. In *Proceedings of the IEEE International Symposium on Information Theory (ISIT '04)*, 2004.
- [IR89] R. Impagliazzo and S. Rudich. Limits on the provable consequences of one-way permutations. In *Proceedings of the 21st Annual ACM Symposium on Theory of Computing (STOC '89)*, pages 186–208. ACM Press, 1989.
- [Kil88] J. Kilian. Founding cryptography on oblivious transfer. In *Proceedings of the 20th Annual ACM Symposium on Theory of Computing (STOC '88)*, pages 20–31. ACM Press, 1988.
- [KM01] V. Korjik and K. Morozov. Generalized oblivious transfer protocols based on noisy channels. In *Proceedings of the International Workshop MMM ACNS*, volume 2052 of *Lecture Notes in Computer Science*, pages 219–229. Springer-Verlag, 2001.
- [LC97] H. K. Lo and H. F. Chau. Is quantum bit commitment really possible? *Physical Review Letters*, 78:3410–3413, 1997.
- [Mau93] U. Maurer. Secret key agreement by public discussion. *IEEE Transaction on Information Theory*, 39(3):733–742, 1993.
- [Mau06] U. Maurer. Lecture notes information security, 2006.
- [May97] D. Mayers. Unconditionally secure quantum bit commitment is impossible. *Physical Review Letters*, 78:3414–3417, 1997.
- [Mor05] K. Morozov. *On Cryptographic Primitives Based on Noisy Channels*. PhD thesis, University of Aarhus, Denmark, 2005.
- [MPW07] R. Meier, B. Przydatek, and J. Wullschleger. Robuster combiners for oblivious transfer. In *Theory of Cryptography Conference — TCC '07*, *Lecture Notes in Computer Science*. Springer-Verlag, 2007.
- [MR92] S. Micali and P. Rogaway. Secure computation (abstract). In *Advances in Cryptology — CRYPTO '91*, volume 576 of *Lecture Notes in Computer Science*, pages 392–404. Springer-Verlag, 1992.



- [MT98] B. Moldovanu and M. Tietzel. Goethe's second-price auction. *The Journal of Political Economy*, 106(4):854–859, 1998.
- [NP01] M. Naor and B. Pinkas. Efficient oblivious transfer protocols. In *Proceedings of the 12th annual ACM-SIAM symposium on Discrete algorithms (SODA '01)*, pages 448–457. Society for Industrial and Applied Mathematics, 2001.
- [NW06] A. Nascimento and A. Winter. On the oblivious transfer capacity of noisy correlations. In *Proceedings of the IEEE International Symposium on Information Theory (ISIT '06)*, 2006.
- [OVY93] R. Ostrovsky, R. Venkatesan, and M. Yung. Fair games against an all-powerful adversary. In *Advances in Computational Complexity Theory*, volume 13 of *AMS DIMACS Series in Discrete Mathematics and Theoretical Computer Science*, pages 155–169. AMS, 1993.
- [PW01] B. Pfitzmann and M. Waidner. A model for asynchronous reactive systems and its application to secure message transmission. In *Proceedings of the 2001 IEEE Symposium on Security and Privacy (SP '01)*, page 184, 2001. Also available at <http://eprint.iacr.org/2000/066>.
- [Rab81] M. O. Rabin. How to exchange secrets by oblivious transfer. Technical Report TR-81, Harvard Aiken Computation Laboratory, 1981.
- [RB89] T. Rabin and M. Ben-Or. Verifiable secret sharing and multiparty protocols with honest majority. In *Proceedings of the 21st Annual ACM Symposium on Theory of Computing (STOC '89)*, pages 73–85. ACM Press, 1989.
- [Rén61] A. Rényi. On measures of information and entropy. In *Proceedings of the 4th Berkeley Symposium on Mathematics, Statistics and Probability*, pages 547–561, 1961.
- [Ren05] R. Renner. *Security of Quantum Key Distribution*. PhD thesis, ETH Zurich, Switzerland, 2005. Available at <http://arxiv.org/abs/quant-ph/0512258>.
- [RK05] R. Renner and R. König. Universally composable privacy amplification against quantum adversaries. In

- Theory of Cryptography Conference — TCC '05*, volume 3378 of *Lecture Notes in Computer Science*, pages 407–425. Springer-Verlag, 2005. Also available at <http://arxiv.org/abs/quant-ph/0403133>.
- [RW05] R. Renner and S. Wolf. Simple and tight bounds for information reconciliation and privacy amplification. In *Advances in Cryptology — ASIACRYPT 2005*, volume 3788 of *Lecture Notes in Computer Science*, pages 199–216. Springer-Verlag, 2005.
- [Sho94] P. Shor. Algorithms for quantum computation: discrete logarithms and factoring. In *Proceedings of the 35th Annual IEEE Symposium on Foundations of Computer Science (FOCS '94)*, pages 124–134, 1994.
- [SV99] A. Sahai and S. Vadhan. Manipulating statistical difference. In *Randomization Methods in Algorithm Design (DIMACS Workshop '97)*, volume 43 of *DIMACS Series in Discrete Mathematics and Theoretical Computer Science*, pages 251–270. American Mathematical Society, 1999.
- [Vad99] S. Vadhan. *A study of statistical zero-knowledge proofs*. PhD thesis, Massachusetts Institute of Technology, USA, 1999.
- [Wie83] S. Wiesner. Conjugate coding. *SIGACT News*, 15(1):78–88, 1983.
- [Wul07] J. Wullschleger. Oblivious-transfer amplification. In *Advances in Cryptology — EUROCRYPT '07*, *Lecture Notes in Computer Science*. Springer-Verlag, 2007.
- [WW04] S. Wolf and J. Wullschleger. Zero-error information and applications in cryptography. In *Proceedings of 2004 IEEE Information Theory Workshop (ITW '04)*, 2004.
- [WW06] S. Wolf and J. Wullschleger. Oblivious transfer is symmetric. In *Advances in Cryptology — EUROCRYPT '06*, volume 4004 of *Lecture Notes in Computer Science*, pages 222–232. Springer-Verlag, 2006.
- [Yao82] A. C. Yao. Protocols for secure computations. In *Proceedings of the 23rd Annual IEEE Symposium on Foundations of Computer Science (FOCS '82)*, pages 160–164, 1982.

## Appendix A

# Appendix

### A.1 Formal Technicalities

**Lemma A.1** (Chernoff/Hoeffding Bound [Che52, Hoe63]). *Let  $P_{X_0 \dots X_n} = P_X^n$  be a product distribution with  $X_i \in [0, 1]$ . Let  $X := \frac{1}{n} \sum_{i=0}^{n-1} X_i$ , and  $\mu = E[X]$ . Then, for any  $\varepsilon > 0$ ,*

$$\begin{aligned}\Pr [X \geq \mu + \varepsilon] &\leq e^{-2n\varepsilon^2}, \\ \Pr [X \leq \mu - \varepsilon] &\leq e^{-2n\varepsilon^2}.\end{aligned}$$

**Lemma A.2** (Cauchy-Schwartz). *For all  $x_0, \dots, x_{n-1}, y_0, \dots, y_{n-1} \in \mathbb{R}$ , we have*

$$\left( \sum_{i=0}^{n-1} x_i y_i \right)^2 \leq \left( \sum_{i=0}^{n-1} x_i^2 \right) \cdot \left( \sum_{i=0}^{n-1} y_i^2 \right).$$

**Lemma A.3.** *For all  $a_0, \dots, a_{n-1} \in \mathbb{R}$ , we have*

$$\left( \sum_{i=0}^{n-1} a_i \right)^2 \leq n \cdot \sum_{i=0}^{n-1} a_i^2.$$

*Proof.* The statement follows from Lemma A.2, choosing  $x_i := 1$  and  $y_i := a_i$ .  $\square$

**Lemma A.4.** For all  $x \in \mathbb{R}$ , we have  $\ln(x+1) \leq x \leq e^{x-1}$ .

*Proof sketch.* The function  $\ln(x+1)$  is convex, and goes through the point  $(0, 0)$  with slope 1, and the function  $e^{x-1}$  is concave, and goes through the point  $(1, 1)$  with slope 1. Hence, we have  $\ln(x+1) \leq x \leq e^{x-1}$ .  $\square$

**Lemma A.5.** For  $0 \leq x \leq 1$ , we have  $1 - \sqrt{1-x} \leq x$ .

*Proof.* From  $(1-x)^2 \leq 1-x$  follows that  $1-x \leq \sqrt{1-x}$ , and hence  $1 - \sqrt{1-x} \leq x$ .  $\square$

**Lemma A.6.** For all  $x, y \in \mathbb{R}$ , we have

$$\left| x - \frac{x+y}{2} \right| + \left| y - \frac{x+y}{2} \right| = |x-y|$$

*Proof.* If  $x \geq y$ , we have

$$\left| x - \frac{x+y}{2} \right| + \left| y - \frac{x+y}{2} \right| = x - \frac{x+y}{2} + \frac{x+y}{2} - y = x - y = |x-y|.$$

The same holds for  $y > x$ .  $\square$

**Lemma A.7.** Let  $X_0$  and  $X_1$  be two independent binary random variables with  $\Pr[X_0 = 1] \leq (1 - \alpha_0)/2$  and  $\Pr[X_1 = 1] \leq (1 - \alpha_1)/2$ , where  $\alpha_0, \alpha_1 \geq 0$ . Then  $\Pr[X_0 \oplus X_1 = 1] \leq (1 - \alpha_0 \alpha_1)/2$ .

*Proof.* For  $\Pr[X_0 = 1] = (1 - \alpha'_0)/2$  and  $\Pr[X_1 = 1] = (1 - \alpha'_1)/2$ , we have

$$\Pr[X_0 \oplus X_1 = 1] = \frac{1 + \alpha'_0}{2} \cdot \frac{1 - \alpha'_1}{2} + \frac{1 - \alpha'_0}{2} \cdot \frac{1 + \alpha'_1}{2} = \frac{1 - \alpha'_0 \alpha'_1}{2}.$$

The lemma follows from the fact that

$$\frac{1 - \alpha'_0 \alpha'_1}{2} \geq \frac{1 - \alpha_0 \alpha_1}{2}$$

for all  $\alpha'_0 \in [\alpha_0, 1]$  and  $\alpha'_1 \in [\alpha_1, 1]$ .  $\square$

**Lemma A.8.** For  $i \in \{0, \dots, n-1\}$ , let  $X_i$  be independent binary random variables where  $\Pr[X_i = 1] \leq \alpha$ , for  $\alpha \leq 1/2$ . Then

$$\Pr[X_0 \oplus \dots \oplus X_{n-1} = 1] \leq \frac{1 - (1 - 2\alpha)^n}{2} \leq n\alpha.$$

*Proof.* The first inequality follows by induction from Lemma A.7, and the second by the union bound, since

$$\Pr[X_0 \oplus \cdots \oplus X_{n-1} = 1] \leq \Pr[\exists i : X_i = 1] \leq n\alpha .$$

□

**Lemma A.9.** For  $i \in \{0, \dots, n-1\}$ , let  $X_i \in \{0, 1\}$  be independently distributed with  $\Pr[X_i = 1] \leq \alpha$ . We have

$$\Pr[X_0 = 1 \vee \cdots \vee X_{n-1} = 1] \leq 1 - (1 - \alpha)^n \leq n\alpha .$$

*Proof.* Follows directly from the union bound.

□

**Lemma A.10.** For  $i \in \{0, \dots, n-1\}$ , let  $X_i \in \{0, 1\}$  be independently distributed with  $\Pr[X_i = 1] \leq \alpha$ . We have

$$\Pr \left[ \sum_{i=0}^{n-1} X_i \geq n/2 \right] \leq \sum_{i=\lceil n/2 \rceil}^n \binom{n}{i} \alpha^i (1 - \alpha)^{n-i} \leq e^{-2n(1/2-\alpha)^2} .$$

*Proof.* We apply Lemma A.1 for  $\mu := \alpha$  and  $\varepsilon := 1/2 - \alpha$ .

□