

On the validity of entropy production principles for linear electrical circuits

Stijn Bruers, Christian Maes¹

Instituut voor Theoretische Fysica, K.U.Leuven

and

Karel Netočný²

Institute of Physics AS CR, Prague

Keywords: entropy production, variational principles, nonequilibrium fluctuations.

Abstract: We discuss the validity of close-to-equilibrium entropy production principles in the context of linear electrical circuits. Both the minimum and the maximum entropy production principle are understood within dynamical fluctuation theory. The starting point are Langevin equations obtained by combining Kirchoff's laws with a Johnson-Nyquist noise at each dissipative element in the circuit. The main observation is that the fluctuation functional for time averages, that can be read off from the path-space action, is in first order around equilibrium given by an entropy production rate.

That allows to understand beyond the schemes of irreversible thermodynamics (1) the validity of the least dissipation, the minimum entropy production, and the maximum entropy production principles close to equilibrium; (2) the role of the observables' parity under time-reversal and, in particular, the origin of Landauer's counterexample (1975) from the fact that the fluctuating observable there is odd under time-reversal; (3) the critical remark of Jaynes (1980) concerning the apparent inappropriateness of entropy production principles in temperature-inhomogeneous circuits.

1. INTRODUCTION

Fluctuation theory is a standard topic in equilibrium thermostatics, and its relation to thermodynamic variational principles is very well understood. In nonequilibrium these studies stem from the fundamental work of Onsager and Machlup, and its various generalizations are nowadays a hot topic, [1, 4, 9]. The existence of a link between variational principles like that of least dissipation and the Onsager-Machlup Langrangians has been known for a long time. However, recent progress in better understanding the role of time-reversal symmetry and its breaking (cf. fluctuation theorems, Jarzynski identity etc., see e.g. Refs. [4, 13]) allows to analyze this in a fresh and more systematic way, and to clean up some old ambiguities and to reinterpret some

¹<http://itf.fys.kuleuven.be/~christ/>

²email: netocny@fzu.cz

of the existing formulations. That is the motivation of the present paper.

A traditional way of illustrating how entropy production principles characterize the behavior of (non)equilibrium systems goes via the study of linear electrical circuits. The reason is that they provide physically clear and mathematically simple testing grounds for these hypotheses. The minimum and maximum entropy production principles have a reputation of being vague or of being at best only sometimes valid. In fact a well known counter example was discussed by Landauer in 1975 showing that the minimum entropy production (MinEP) principle may not be satisfied even close to equilibrium, [10, 11]. A more general criticism was exposed by Jaynes, starting with the remark that the MinEP does not even work when in a network the resistors are kept at different temperatures, [8]. Surprisingly, it has not stopped people from applying MinEP in a variety of contexts and from inventing new proofs for it, see e.g. [17] for a critical review.

In the present paper we illustrate our new understanding of these principles via dynamical fluctuation theory. No longer is it solely a matter of verifying these entropy principles but of explaining their origin and their approximate nature. More mathematical details are in [16]. There are two particular steps in our analysis. First we connect the discussion with more recent work in nonequilibrium statistical mechanics, in particular as described in [14, 13]. We construct a Lagrangian governing the distribution of system trajectories; the entropy production is identified with the source term of time-reversal breaking in that Lagrangian. Secondly, we explain how the entropy production principles can be derived from the fluctuation theory constructed from the Lagrangian. The basic input is the observation that the rate function for certain stationary dynamical fluctuations is in a direct relation with the entropy production rate, when close to equilibrium and under specific conditions. This yields an extension of the classical work by Onsager and Machlup [18] which enables to systematically generate various variational characterizations of the stationary state. Among these we discuss the validity of both the MinEP and of its counterpart in the maximum entropy production principle (MaxEP). In particular we revisit Landauer's counter example and we show why the conditions for the validity of the MinEP are not verified.

The plan of the paper is as follows. In the next section we introduce the general framework and formulate the main questions for which we give general answers. Afterwards we discuss some generic linear electrical circuits to illustrate the main points of the theory.

The paper is part of a series of papers in which the entropy production principles are revisited and extended, also in the light of recent advances in nonequilibrium statistical mechanics, [15, 16, 2].

The number of references on entropy production principles is enormous, mostly however within the formalism of irreversible thermodynamics. We mention some but only a tiny fraction of them in the course of the paper. As is well known, much of the pioneering work was of course done by Ilya Prigogine, see Refs. [19, 6]. As a discussion of some conceptual points, we mention Refs. [8, 12].

2. SET-UP AND GENERAL STRATEGY

In the present paper we explain when entropy production principles can be expected to yield correct physical information. That will be illustrated in the context of linear electrical circuits. Given such a network there is often an immediate phenomenological expression of the entropy production rate $\dot{S}(X, \dot{X})$ as a function of the relevant variables $X = (X_\alpha)$ (potentials, currents), their time-derivatives \dot{X} , and in terms of the network parameters (values of the electrical elements). From $\dot{S}(X, \dot{X})$ we can still construct other entropy production variables, e.g. by substituting a dynamical law for \dot{X} one obtains a *typical* entropy production rate at state X . The question is now when and why the correct physical values for the potentials and/or the currents minimize or perhaps maximize these entropy production rates, in whatever form. The question and part of the answer will become more clear below. We will then give examples of networks, write down the relevant entropy production and show how it can serve, if at all, as a variational functional.

Our treatment of electrical circuits relies on the use of Kirchoff equations that themselves assume a quasi-stationary regime of the Maxwell equations, thus forgetting about the dynamics of the electromagnetic field. The resulting differential equations are well known and their stationary solutions are in the standard textbooks. Obviously our goal is not to study linear electrical networks; in the present paper we use them merely as an example to illustrate why and how nonequilibrium behavior can or cannot be obtained from variational principles for the entropy production. We refer to e.g. [7] for other and further illustrations of the use of electrical networks in studies of nonequilibrium physics, also using stochastic methods.

For that purpose, Kirchoff's differential equations will be embedded in stochastic equations whose averaged behavior reproduces the deterministic equation. Not only does that enable the use of stochastic methods but there is also a good physical reason to include extra noise. In accord with the fluctuation-dissipation theorem, the thermal agitations in a resistor are related to the distribution of the random electric field acting upon the electrons. As a consequence, a random voltage

emerges and can be measured at the ends of the resistor (Johnson effect). That voltage can be described as a random process U_t^f given by the Nyquist formula:

$$U_t^f dt = \sqrt{\frac{2R}{\beta}} dW_t, \quad \text{or} \quad U_t^f = \sqrt{\frac{2R}{\beta}} \xi_t \quad (2.1)$$

with R the resistance, W_t a standard Wiener process and more formally, ξ_t a standard white noise; the prefactor is of course very small by the presence of Boltzmann's constant in $\beta^{-1} = k_B T$, at least when compared to macroscopic voltage values. Hence, every 'real' resistor can be equivalently represented as an ideal resistor in series with the random voltage source U_t^f . Using such a representation for all resistors present, we can study fluctuations in an arbitrary electrical circuit. The resistors in the network are the only source of fluctuations and of steady dissipation. Apart from the transient contributions coming from capacitances or inductances, each resistor R through which a current I flows and which is kept in thermal contact with a reservoir at temperature β^{-1} , contributes a steady term $\beta R I^2$ to the entropy production. Having thus determined the entropy production rate $\dot{S}(X, \dot{X})$ for the electrical circuit, we must understand how it gives rise to a variational principle for the variables in the network.

The following can be skipped at first reading and one can choose to go directly to the examples in Section 3.

The line of reasoning will be as follows. For a given electrical circuit we write down (first law) the conservation of charge, that the sum of all currents equals zero at every node, and (second law) the conservation of energy, that the sum of all potential(differences) over any loop equals zero. In those we take care to add with every resistor the random process U_t^f for an additional fluctuating potential difference. The basic variables are then the potentials and the currents satisfying linear stochastic differential equations of the generic form

$$\dot{X}_\alpha(t) = f_\alpha + \sum_\gamma c_{\alpha,\gamma} X_\gamma(t) + \sqrt{\frac{2}{v_\alpha}} \xi_\alpha(t) \quad (2.2)$$

where the $\xi_\alpha(t)$ are mutually independent standard white noises; the X_α represent the fluctuating variables (currents and potentials that can be chosen freely); the constants $v_\alpha, c_{\alpha,\gamma}$ are determined from Kirchoff's laws and from the Nyquist formula (2.1) and the f_α is the external "force" (such as from an external source or battery). We will see equation (2.2) specified in (3.2), (3.8), (3.16), and (3.24).

That stochastic dynamics induces a probability distribution \mathbf{P} on histories ω , where for each time t , $\omega_t = (X_\alpha(t))_\alpha$ states the values of the potentials and of the currents. The action in \mathbf{P} is readily computed

from Itô-stochastic analysis:

$$\mathbf{P}(\omega) \propto \exp\left[-\int dt \mathcal{L}(\omega_t, \dot{\omega}_t)\right]$$

with Onsager-Machlup Lagrangian, formally,

$$\mathcal{L}(X, \dot{X}) = \frac{1}{4} \sum_{\alpha} v_{\alpha} (\dot{X}_{\alpha} - f_{\alpha} - \sum_{\gamma} c_{\alpha,\gamma} X_{\gamma})^2 \quad (2.3)$$

From a mathematical point of view, such expressions are justified within the Freidlin-Wentzell theory of stochastic perturbations of deterministic evolutions [3]. Observe that $v_{\alpha} = O(\beta)$ in the electrical circuits and $v_{\alpha} f_{\alpha}^2$ is a very high frequency for not too high temperatures; therefore the typical trajectories are $\dot{X}_{\alpha} = f_{\alpha} + \sum_{\gamma} c_{\alpha,\gamma} X_{\gamma}$ and β^{-1} can be taken as a perturbation parameter in the theory.

Each time in the examples below, we will explicitly write down that Lagrangian, see (3.4), (3.9), (3.17), and (3.25).

When applying the general model (2.2) to a particular physical problem, we always have to satisfy a consistency condition: that the antisymmetric term under time-reversal in \mathcal{L} is the physically correct entropy production $\dot{S}(X, \dot{X})$, usually *a priori* known from the context. It means the entropy production must satisfy

$$\mathcal{L}(\varepsilon X, -\varepsilon \dot{X}) - \mathcal{L}(X, \dot{X}) = \dot{S}(X, \dot{X}) \quad (2.4)$$

with $(\varepsilon X)_{\alpha} = \varepsilon_{\alpha} X_{\alpha}$ for parities $\varepsilon_{\alpha} = \pm 1$, labelling the (anti)symmetry under kinematical time-reversal. E.g., $\varepsilon_{\alpha} = 1$ (or -1) if X_{α} is a voltage (or current). In our linear electrical circuits, that is ensured by satisfying the fluctuation-dissipation relation by taking (2.1) as noise terms, in combination with a suitable choice of variables or of the level of description. The latter point is subtle: using a too coarse grained level of description one can easily ‘become blind’ to some contributions to the total entropy production. Relation (2.4) will be checked in each example below, see (3.7), (3.13), (3.18), and (3.25).

When there is no driving (no external force nor battery nor differences in temperature,...) the dynamics certainly reduces to that of an equilibrium system in which case the entropy production rate (2.4) must be a total time derivative:

$$\int_{t_0}^{t_1} dt \dot{S}(X(t), \dot{X}(t)) = \beta [H(X(t_1)) - H(X(t_0))] \quad (2.5)$$

for some energy function $H(X)$ and some inverse temperature β . The equation (2.5) formulates the condition of detailed balance.

2.1. Transient entropy production principles. For the purpose of obtaining variational principles, we must look back at the Lagrangian (2.3). We can for example fix a history $(X_{\alpha}(s))$ for times $s \leq t$ before some fixed t and ask what is the most probable immediate future.

Clearly, it amounts to finding the $(\dot{X}_\alpha(t))$ that minimize $\mathcal{L}(X(t), \dot{X}(t))$, i.e., to minimize

$$\mathcal{D}_1(X, \dot{X}) = \frac{1}{4} \sum_{\alpha} v_{\alpha} [\dot{X}_{\alpha}^2 - 2\dot{X}_{\alpha}(f_{\alpha} + \sum_{\gamma} c_{\alpha,\gamma} X_{\gamma})] \quad (2.6)$$

That is traditionally called the least dissipation principle because when all variables are even, $\varepsilon_{\alpha} = 1$, it is easily checked that

$$2\mathcal{D}_1(X, \dot{X}) = \frac{1}{2} \sum_{\alpha} v_{\alpha} \dot{X}_{\alpha}^2 - \dot{S}(X, \dot{X}) \quad (2.7)$$

which can be traced back to mechanical and equilibrium analogues given by Rayleigh and Onsager, see [18]; the expression

$$\mathcal{D}(\dot{X}) = \sum_{\alpha} v_{\alpha} \dot{X}_{\alpha}^2 \quad (2.8)$$

is sometimes called the dissipation function. The typical behavior $\dot{X}_{\alpha} = f_{\alpha} + \sum_{\gamma} c_{\alpha,\gamma} X_{\gamma}$ as expected from (2.2), can thus be characterized as the one minimizing (2.7) (still under the condition that all $\varepsilon_{\alpha} = 1$). We can rewrite that as a (transient) maximum entropy production principle (discussed in e.g. Ref. [20]). Indeed, minimizing (2.7) over the \dot{X} (for given X) is equivalent with maximizing $\dot{S}(X, \dot{X})$ under the additional constraint that $\mathcal{D}(\dot{X}) = \dot{S}(X, \dot{X})$.

Alternatively, we can fix the \dot{X}_{α} 's in (2.3) and we collect the free variable part of (2.3) in what we call \mathcal{D}_2 ; we must then find the X_{α} 's minimizing

$$\begin{aligned} \mathcal{D}_2(X, \dot{X}) = & \frac{1}{4} \sum_{\alpha} v_{\alpha} [(\sum_{\gamma} c_{\alpha,\gamma} X_{\gamma})^2 \\ & - 2(\dot{X}_{\alpha} - f_{\alpha}) \sum_{\gamma} c_{\alpha,\gamma} X_{\gamma}] \end{aligned} \quad (2.9)$$

The solution will give us the typical X_{α} 's. When now all the variables are odd, $\varepsilon_{\alpha} = -1$, that reduces to minimizing

$$2\mathcal{D}_2(X, \dot{X}) = \frac{1}{2} \sum_{\alpha} v_{\alpha} (\sum_{\gamma} c_{\alpha,\gamma} X_{\gamma})^2 - \dot{S}(X, \dot{X}) \quad (2.10)$$

With the definition of typical (or expected) entropy production

$$\sigma(X) = \dot{S}(X, \dot{X} = f + \sum_{\gamma} c_{\cdot,\gamma} X_{\gamma}) \quad (2.11)$$

the expression (2.10) can be rewritten as

$$2\mathcal{D}_2(X, \dot{X}) = \frac{1}{2} \sigma(X) - \dot{S}(X, \dot{X}) \quad (2.12)$$

which we have to minimize over the X_α 's or, alternatively, $\dot{S}(X, \dot{X})$ has to be maximized under the constraint $\dot{S}(X, \dot{X}) = \sigma(X)$.

Remark that if either a) all variables are even and driving forces arbitrary, or b) all variables are odd and the forces absent, $f_\alpha \equiv 0$, then both the variational principles $\mathcal{D}(\dot{X})/2 - \dot{S}(\cdot, \dot{X}) = \min$ (2.7) and $\sigma(X)/2 - \dot{S}(X, \cdot) = \min$ (2.12) are valid and in a sense dual. The reason is that they are both corresponding to a relaxation to equilibrium with Lagrangian taking the symmetric form

$$2\mathcal{L}(X, \dot{X}) = \frac{1}{2}\mathcal{D}(\dot{X}) - \dot{S}(X, \dot{X}) + \frac{1}{2}\sigma(X) \quad (2.13)$$

a scenario originally considered by Onsager and Machlup [18]. However, that structure needs a modification when a true nonequilibrium driving is present and/or when even and odd variables mix with each other. (There was already an example above when all variables were odd and a driving force was switched on.)

In applications, most interesting is the stationary regime for which $\dot{X} = 0$. We discuss that at large in the next section.

2.2. Stationary entropy production principles. For the stationary regime, we obtain a variational functional by simply putting $\dot{X}_\alpha = 0$ in the Lagrangian (2.3) to get

$$\mathcal{J}(X) = \frac{1}{4} \sum_\alpha v_\alpha (f_\alpha + \sum_\gamma c_{\alpha,\gamma} X_\gamma)^2 \quad (2.14)$$

A more fundamental point is that \mathcal{J} is the large deviation rate function for empirical averages $\int_0^T X(t) dx/T$ when $T \uparrow \infty$, i.e.,

$$\mathbf{P} \left[\frac{1}{T} \int_0^T X(t) dt = x \right] \simeq \exp[-T\mathcal{J}(x)] \quad (2.15)$$

The mathematical theory of such large deviations was initiated by Donsker and Varadhan, see [5, 3]. Equation (2.15) resembles Einstein's formula for equilibrium fluctuations from which various variational characterizations of equilibrium follow, in terms of entropy and related potentials, see also Ref. [15]. Our line of thinking is similar here: a systematic way to obtain meaningful nonequilibrium variational principles is to consider dynamical large deviations. That point of view gets of course more interesting when the stationary state is less explicit, like for mesoscopic systems or for more general Markov processes [16] far from equilibrium, possibly with time-dependent driving etc.

2.2.1. *Even variables.* When all fluctuating variables are even under time-reversal (all $\varepsilon = +1$), then it is easy to verify that

$$\mathcal{J}(X) = \frac{1}{4}\sigma(X) \quad (2.16)$$

see e.g. (2.13). Thus, in that case, we get the typical (equilibrium) values for the X by minimizing the entropy production $\sigma(X)$, which becomes zero in equilibrium. The most basic example is in Section 3.1.

2.2.2. *Odd variables.* Including variables that are odd under time-reversal is necessary in order to obtain a truly nonequilibrium stationary state in the present framework. We first investigate what happens when we have *only* odd variables.

The basic idea is always that we must minimize $\mathcal{J}(X)$ but now it differs from the physical entropy production. That is in accord with a general observation that for odd variables the minimum entropy production principle does not apply. Instead, minimizing $\mathcal{J}(X)$ can now be understood as a certain maximum entropy production principle. The reason is that for odd variables

$$2\mathcal{J}(X) = \frac{1}{2}\sigma(X) - \dot{S}(X, 0) + \frac{1}{2}\sum_{\alpha} v_{\alpha} f_{\alpha}^2 \quad (2.17)$$

Hence, we need to minimize

$$\frac{1}{2}\sigma(X) - \dot{S}(X, 0) \quad (2.18)$$

In the stationary case, we have $\sigma(X) = \dot{S}(X, 0)$. Thence, minimizing $\mathcal{J}(X)$ amounts to maximizing the entropy production $\sigma(X)$ under the constraint that $\sigma(X) = \dot{S}(X, 0)$. That repeats the discussion after (2.12), but this time for the stationary case $\dot{X} = 0$.

The required modification of the MinEP (to minimizing (2.18)) when dealing with odd variables is also how Landauer's counter example [10, 11] should be understood. The details are in Section 3.2.

2.2.3. *Even and odd.* The above equations (2.16, 2.17) have been obtained for dynamical variables that are either all even or all odd under time-reversal. We can make that more general. Suppose our Lagrangian includes both time-reversal even and odd variables: $\{X_{\alpha}\} = \{X_i^+, X_i^-\}$, where it is understood that the X_i^+ are even and that the X_i^- are odd under time-reversal. The Lagrangian (2.3) now takes the form (in obvious notation):

$$\begin{aligned} \mathcal{L}(X, \dot{X}) = & \frac{1}{4}\sum_{i+} v_i^+ (\dot{X}_i^+ - f_i^+ - \sum_{j+} c_{ij}^{++} X_j^+ - \sum_{j-} c_{ij}^{+-} X_j^-)^2 \\ & + \frac{1}{4}\sum_{i-} v_i^- (\dot{X}_i^- - f_i^- - \sum_{j+} c_{ij}^{-+} X_j^+ - \sum_{j-} c_{ij}^{--} X_j^-)^2 \end{aligned} \quad (2.19)$$

Remember that from the beginning we restrict ourselves to external driving forces which are even under time-reversal; for odd driving forces already (2.4) needs a modification but an analogous reasoning applies.

Let us first consider the entropy production rates. After some calculation, we find for the expected entropy production (2.11):

$$\begin{aligned} \sigma(X^+, X^-) &= \sum_{i^+} v_i^+ (f_i^+ + \sum_{j^+} c_{ij}^{++} X_j^+)^2 \\ &\quad + \sum_{i^-} v_i^- (\sum_{j^-} c_{ij}^{--} X_j^-)^2 \end{aligned} \quad (2.20)$$

From this we can further construct a function of the even and a function of the odd variables. We thus get two additional, even and odd, expected entropy production rates $\sigma^+(X^+)$ and $\sigma^-(X^-)$ given as

$$\begin{aligned} \sigma^+(X^+) &= \sigma(X^+, X^-(X^+)) \\ \sigma^-(X^-) &= \sigma(X^+(X^-), X^-) \end{aligned} \quad (2.21)$$

where for the first (even) case we insert $X^- = X^-(X^+)$ from solving the stationary condition

$$f_i^- + \sum_{j^+} c_{ij}^{-+} X_j^+ + \sum_{j^-} c_{ij}^{--} X_j^- = 0$$

and likewise, for the second (odd) case we substitute $X^+ = X^+(X^-)$ as found from

$$f_i^+ + \sum_{j^+} c_{ij}^{++} X_j^+ + \sum_{j^-} c_{ij}^{+-} X_j^- = 0$$

That will be explicitly visible and done in (3.22).

The large deviation rate function (2.14) can also be calculated:

$$\begin{aligned} 4\mathcal{J}(X^+, X^-) &= \sum_{i^+} v_i^+ [(f_i^+ + \sum_{j^+} c_{ij}^{++} X_j^+)^2 + (\sum_{j^-} c_{ij}^{+-} X_j^-)^2 \\ &\quad + 2(f_i^+ + \sum_{j^+} c_{ij}^{++} X_j^+) (\sum_{j^-} c_{ij}^{+-} X_j^-)] \\ &\quad + \sum_{i^-} v_i^- [(f_i^- + \sum_{j^+} c_{ij}^{-+} X_j^+)^2 + (\sum_{j^-} c_{ij}^{--} X_j^-)^2 \\ &\quad + 2(f_i^- + \sum_{j^+} c_{ij}^{-+} X_j^+) (\sum_{j^-} c_{ij}^{--} X_j^-)] \end{aligned}$$

To simplify the structure, we make here the (nontrivial) assumption that the even and the odd variables do not mix in \mathcal{J} . Hence, we require that

$$\mathcal{J}(X^+, X^-) = \mathcal{J}^+(X^+) + \mathcal{J}^-(X^-) \quad (2.22)$$

(i.e., the cross terms are zero), with

$$\begin{aligned}
4\mathcal{J}^+(X^+) &= \sum_{i+} v_i^+ (f_i^+ + \sum_{j+} c_{ij}^{++} X_j^+)^2 \\
&\quad + \sum_{i-} v_i^- (f_i^- + \sum_{j+} c_{ij}^{-+} X_j^+)^2
\end{aligned} \tag{2.23}$$

and analogously for $\mathcal{J}^-(X^-)$, see below in (2.25). That decoupling of the even from the odd variables in the rate function \mathcal{J} , implies the relation

$$4\mathcal{J}^+(X^+) = \sigma^+(X^+) \tag{2.24}$$

which is a generalization of (2.16).

Remember now that we must minimize \mathcal{J} (here of the form (2.22)) to obtain the typical stationary values. Hence, if indeed the time-symmetric and time-antisymmetric variables in \mathcal{J} decouple, then (2.24) tells that we should minimize the expected entropy production σ^+ . We will see an example below in Section 3.3.

There is also a MaxEP principle in the above setting. Write \mathcal{J}^- as

$$\begin{aligned}
4\mathcal{J}^- &= \sum_{i+} v_i^+ \left(\sum_{j-} c_{ij}^{+-} X_j^- \right)^2 + \sum_{i-} v_i^- \left(\sum_{j-} c_{ij}^{--} X_j^- \right)^2 \\
&\quad + 2 \sum_{i+} v_i^+ f_i^+ \sum_{j-} c_{ij}^{+-} X_j^- + 2 \sum_{i-} v_i^- f_i^- \sum_{j-} c_{ij}^{--} X_j^- \\
&= \sigma^-(X^-) - 2\mathcal{P}(f, X^-)
\end{aligned} \tag{2.25}$$

where \mathcal{P} can be interpreted as the power input from the external forces f . Suppose we take the constraint $\sigma^- = \mathcal{P}$ meaning that the delivered work is completely dissipated and there is no accumulation of internal energy (true indeed in the stationary state when $\dot{X} = 0$). Minimizing $\mathcal{J}^-(X^-)$ under the constraint $\sigma^- = \mathcal{P}$ is equivalent to maximizing σ^- under the same constraint. That MaxEP principle was used similarly in Ref. [21].

3. EXAMPLES

We demonstrate the above general theory on a few simple examples of linear circuits. In particular we will see that close to equilibrium the rate function \mathcal{J} can indeed be split in the even and odd parts, and hence, depending on the choice of variables, we obtain MinEP or MaxEP principle.

3.1. RC in series. Consider a resistance R in series with a capacity C and with a steady voltage source E . Write $U = U_t$ for the variable potential difference over the capacitor. Kirchhoff's second law reads

$$RC\dot{U} = E - U + U^f \tag{3.1}$$

By inserting the white noise ξ_t following (2.1), we are to study the Langevin equation

$$\dot{U}_t = \frac{E - U_t}{RC} + \sqrt{\frac{2}{\beta RC^2}} \xi_t \quad (3.2)$$

There is no other free variable apart from U ; in particular, the current $I = C\dot{U}$. A standard reasoning proves the consistency of this model: with the battery removed, $E = 0$, the dynamics is reversible with respect to the Gibbs distribution at inverse temperature β and with energy function $H(U) = CU^2/2$. In particular, $\lim_{t \rightarrow \infty} \langle U_t^2 \rangle = (\beta C)^{-1}$, in accordance with the equipartition theorem.

Heuristically, the entropy production rate $\sigma(U)$ as a function of the voltage U on the capacitor is simply the Joule heating in the resistor R :

$$\sigma(U) = \beta \frac{(E - U)^2}{R} \quad (3.3)$$

Apparently, its minimizer $U^* = E$ coincides with the correct value for the stationary voltage, verifying the MinEP principle.

We can understand that within our general framework. The Onsager-Machlup Lagrangian $\mathcal{L}(U, \dot{U})$ of the process U_t is

$$\mathcal{L}(U, \dot{U}) = \frac{\beta RC^2}{4} \left(\dot{U} - \frac{E - U}{RC} \right)^2 \quad (3.4)$$

From \mathcal{L} we can derive the fluctuations of the empirical voltage $U_T = \int_0^T U_t dt / T$. The stationary ($T \uparrow +\infty$) fluctuations of U_T are given by (2.14)-(2.15):

$$\mathbf{P}[U_T \simeq u] \propto \exp[-T\mathcal{J}(u)] \quad (3.5)$$

with rate function

$$\mathcal{J}(U) = \mathcal{L}(U, 0) = \frac{1}{4}\sigma(U) \quad (3.6)$$

The fluctuation law (3.5) thus gives a variational principle for the stationary voltage just coinciding with the MinEP principle: the most probable value for the time-averaged voltage is obtained by minimizing $\mathcal{J}(U) = \sigma(U)/4$.

In fact, this is just a particular example of the relation (2.16). To see that we still have to check that our model is consistent with relation (2.4). Indeed,

$$\dot{S}(U, \dot{U}) = \mathcal{L}(U, -\dot{U}) - \mathcal{L}(U, \dot{U}) = \beta C \dot{U} (E - U) \quad (3.7)$$

is the physical entropy production rate, and its typical value (2.11) equals

$$\dot{S}(U, \dot{U} = \frac{E - U}{RC}) = \sigma(U)$$

verifying (3.3) above. Hence, from the fluctuation point of view, the manifest validity of the MinEP principle for this RC-circuit is nothing

but a consequence of the invariance of the voltage (or charge) with respect to time-reversal.

3.2. RL in series. If the capacity in the previous section is replaced with an inductance L , the situation remarkably changes. In that case, Kirchhoff's second law for the current I becomes

$$RI - U^f + L \frac{dI}{dt} = E$$

(where the minus sign is chosen for convenience only), or, inserting the white noise ξ_t from (2.1),

$$\dot{I}_t = \frac{E - RI_t}{L} + \sqrt{\frac{2R}{\beta L^2}} \xi_t \quad (3.8)$$

That is again a linear Langevin equation, but now the fluctuations concern the current I_t which is odd under time-reversal.

We can try to repeat the same as in the previous section. The Lagrangian now equals

$$\mathcal{L}(I, \dot{I}) = \frac{\beta L^2}{4R} \left(\dot{I} - \frac{E - RI}{L} \right)^2 \quad (3.9)$$

The construction of the fluctuation rate $\mathcal{J}(I)$ for the empirical current $\int_0^T I_t dt / T$ can again be done following (2.14)-(2.15) with the result

$$\mathcal{J}(I) = \mathcal{L}(I, \dot{I} = 0) = \frac{\beta R}{4} \left(I - \frac{E}{R} \right)^2 \quad (3.10)$$

As generally true, the minimum of \mathcal{J} over I is given by the correct stationary value. However, that \mathcal{J} clearly differs from the physical entropy production the expected rate of which is now

$$\sigma(I) = \beta R I^2 \quad (3.11)$$

So while we can find the most probable current $I^* = E/R$ by minimizing $\mathcal{J}(I)$, it does not correspond to a minimization of the entropy production. Indeed, our RL-circuit is the classical example first given by Landauer through which we see that the MinEP principle is not generally valid and 'not reliable' when applied to macroscopic systems, even in the linear irreversible regime. We can now however understand what is the real cause of that effect.

Similarly to (3.6)-(3.7), the variational functional $\mathcal{J}(I)$ of (3.10) for the stationary current satisfies

$$\mathcal{J}(I) = \frac{1}{4} [\mathcal{L}(I, -\dot{I}) - \mathcal{L}(I, \dot{I})] \Big|_{\dot{I} = \frac{E - RI}{L}} \quad (3.12)$$

but $\mathcal{L}(I, -\dot{I}) - \mathcal{L}(I, \dot{I})$ does not longer coincide with the variable entropy production \dot{S} . Since the current is odd under time reversal, the latter is rather, see (2.4),

$$\dot{S}(I, \dot{I}) = \mathcal{L}(-I, \dot{I}) - \mathcal{L}(I, \dot{I}) = \beta I(E - L\dot{I}) \quad (3.13)$$

in accordance with the phenomenology; note that the equilibrium dynamics (i.e. (3.8) with $E = 0$) satisfies detailed balance with energy function $H(I) = LI^2/2$.

Via our fluctuation approach we thus understand the origin of the problem: the MinEP principle is generally valid only for Markovian dynamical systems described via a collection of observables that are symmetric under time-reversal. The Markovian property refers to the first order (in time) of the dynamical equation and indicates that the variable in question thus satisfies an autonomous equation.

Observe that we now see appear the ‘true’ variational principle for the stationary current as was explained under (2.17)-(2.18): for odd observables the above argument proposes a different functional that replaces the entropy production $\sigma(I)$ and that can here be chosen as

$$\frac{1}{2}\sigma(I) - \dot{S}(I, 0)$$

as follows from (3.10) written in the form

$$\mathcal{J}(I) = \frac{1}{4}\sigma(I) - \frac{1}{2}\dot{S}(I, 0) + \frac{\beta E^2}{4R}$$

As the stationary value I^* satisfies $\sigma(I^*) = S(I^*, 0)$, we can also state the above variational principle as a maximum entropy production principle: we must maximize $\sigma(I)$ subject to the condition that $\dot{S}(I, 0) = \sigma(I)$.

3.3. RR in series. Consider an electrical circuit consisting of a battery E coupled to resistors in series. Appending an independent Nyquist random voltage source U_k^f to all resistances R_k , we get that the current I fluctuates according to

$$I \sum_k R_k = E + \sum_k U_k^f \quad (3.14)$$

Here, the current follows a *singular* Markov process of the form of a white noise. We can however modify that singular dynamics so that it becomes a regular Markov process and so that the (averaged) stationary current remains unchanged. An important addition to the discussion is to see the effect of assigning different temperatures β_k to the individual resistors, as it was claimed that such an extension would again yield a counter example to the MinEP, [8].

For regularization we choose to add an inductance in series with the resistors so that a non-trivial transient regime can arise. However, adding only an inductance gives a too coarse grained description, because as

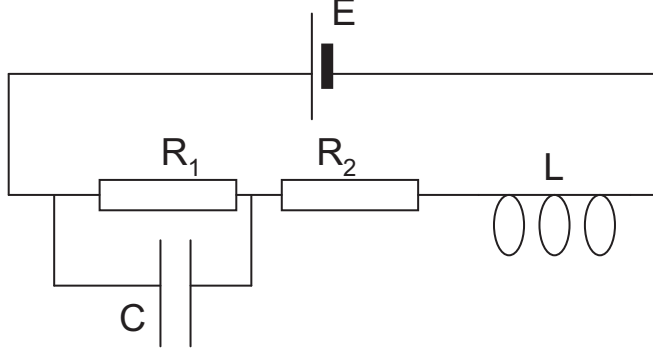

FIGURE 1. The regularized RR-circuit.

one can check, then (2.4) would not be satisfied with the correct expression for the entropy production. That can be solved by adding a capacitance in parallel with one of the resistors, see Fig. 1. We thus have an effective RLC-circuit with two resistors in series and one external voltage. The two independent free variables are the potential U over the first resistor and the current I through the second resistor. The variational functional (2.14) or the expected entropy production (2.11) will not depend on the auxiliary inductance L or on the capacitance C .

The dynamical equations are given by Kirchoff's laws:

$$\begin{aligned}\dot{U} &= \frac{I}{C} - \frac{U}{R_1 C} + \frac{U_1^f}{R_1 C} \\ \dot{I} &= \frac{E - R_2 I - U}{L} + \frac{U_2^f}{L}\end{aligned}\tag{3.15}$$

where always from (2.1), $U_{1,2}^f dt = \sqrt{2R_{1,2}\beta_{1,2}^{-1}} dW_t$. The equilibrium dynamics ($E = 0, \beta_1 = \beta_2 = \beta$ in (3.15)) can be written as

$$\begin{aligned}\dot{U} &= \frac{1}{LC} \frac{\partial H}{\partial I} - \gamma_1 \frac{\partial H}{\partial U} + \sqrt{\frac{2\gamma_1}{\beta}} \xi_1 \\ \dot{I} &= -\frac{1}{LC} \frac{\partial H}{\partial U} - \gamma_2 \frac{\partial H}{\partial I} + \sqrt{\frac{2\gamma_2}{\beta}} \xi_2\end{aligned}\tag{3.16}$$

for energy function $H(U, I) = (CU^2 + LI^2)/2$ and friction coefficients $\gamma_1 = 1/(R_1 C^2)$, $\gamma_2 = R_2/L^2$; the ξ_1 and ξ_2 are independent standard white noises. The first terms on the right hand-side of (3.16) specify a Hamiltonian dynamics for the pair (U, I) , while the other terms balance the dissipation and the random forcing.

The (nonequilibrium) Lagrangian is obtained from (3.15) as

$$\begin{aligned}\mathcal{L}(U, I; \dot{U}, \dot{I}) &= \frac{\beta_1 R_1 C^2}{4} \left(\dot{U} - \frac{I}{C} + \frac{U}{R_1 C} \right)^2 \\ &\quad + \frac{\beta_2 L^2}{4R_2} \left(\dot{I} + \frac{R_2 I}{L} - \frac{E - U}{L} \right)^2\end{aligned}\tag{3.17}$$

and the variable entropy production (2.4) is

$$\begin{aligned}\dot{S}(U, I; \dot{U}, \dot{I}) &= \mathcal{L}(U, -I; -\dot{U}, \dot{I}) - \mathcal{L}(U, I; \dot{U}, \dot{I}) \\ &= \beta_1 U(I - C\dot{U}) + \beta_2 I(E - U - L\dot{I})\end{aligned}\tag{3.18}$$

as it should. One recognizes indeed the dissipation in each resistor; $I - C\dot{U}$ is the current through resistor 1 and $E - U - L\dot{I}$ is the voltage at resistor 2. Thus, the expected entropy production (2.11) is

$$\sigma(U, I) = \beta_1 \frac{U^2}{R_1} + \beta_2 R_2 I^2\tag{3.19}$$

On the other hand, the true variational functional (2.14)-(2.15) is directly obtained from (3.17):

$$\begin{aligned}4\mathcal{J}(U, I) &= \sigma(U, I) + \beta_1 R_1 I^2 + \beta_2 \frac{(E - U)^2}{R_2} \\ &\quad - 2[\beta_1 U I + \beta_2 (E - U) I]\end{aligned}\tag{3.20}$$

and differs from the entropy production because we have both an even (the potential U) and an odd (the current I) degree of freedom; compare with (2.16) and (2.17) valid in the case of only even respectively only odd variables. So now we have to go to the formalism with mixed variables as in (2.19)–(2.25). Although \mathcal{J} does not exactly split into even and odd parts as in (2.22), it does approximately close to equilibrium: if $\beta = \beta_1 = \beta_2 + \epsilon$, we have

$$\begin{aligned}4J(U, I) &= \beta \left[\frac{U^2}{R_1} + \frac{(E - U)^2}{R_2} \right] + \beta(R_1 + R_2)I^2 \\ &\quad - 2\beta EI + O(\epsilon)\end{aligned}\tag{3.21}$$

which is of the form (2.22). Since the even and the odd versions (2.21) of the entropy production rate are

$$\sigma^+(U) = \beta_1 \frac{U^2}{R_1} + \beta_2 \frac{(E - U)^2}{R_2} = \beta \left[\frac{U^2}{R_1} + \frac{(E - U)^2}{R_2} \right] + O(\epsilon)\tag{3.22}$$

and

$$\sigma^-(I) = \beta_1 R_1 I^2 + \beta_2 R_2 I^2 = \beta(R_1 + R_2)I^2 + O(\epsilon)\tag{3.23}$$

the minimization of \mathcal{J} provides us with the next two variational principles:

First, the stationary voltage U^* is obtained from minimizing $\mathcal{J}^+(U) =$

$\sigma^+(U)/4$, which is a (generalized) MinEP principle (2.24). Second, minimizing $\mathcal{J}^-(I) = \sigma^-(I) - 2\beta EI$ or, equivalently, maximizing σ^- under the constraint $\sigma^-(I) = \beta EI$ yields the stationary current I^* ; this is an example on the MaxEP principle (2.25).

An important remark is that the above derivation of the MinEP and the MaxEP principles was based not only on the assumption that the temperature is approximately homogenous but also on the linearity of the stochastic model(s) under consideration. They should be really taken as a (linear) approximation around detailed balance. In particular, also the current I and the forces U and E should be considered of order $O(\epsilon)$, together with the assumed $\beta_2 = \beta_1 + O(\epsilon)$. The above then means that the MinEP and MaxEP principles are only valid up to order $O(\epsilon^2)$, i.e. within the linear irreversible regime; see [16] for some more details.

In view of this remark we understand better why these principles do not carry over to temperature-inhomogeneous circuits: in our simple circuits the temperature gradients are *redundant* thermodynamic forces in the sense that they do not generate electric currents by themselves; they only modify the dynamics of fluctuations. Hence, these gradients yield corrections of order $o(\epsilon^2)$, beyond the resolution of the MinEP/MaxEP principles. This solves the remarks by Jaynes [8]. Apparently, the picture would get completely changed by adding e.g. a thermocouple into the network.

3.4. RR in parallel. For the sake of completeness, we finally consider two resistors in parallel and coupled with an external voltage source E . The independent variables are the currents I_1 and I_2 through the two resistors. To have a dynamics consistent with our condition (2.4) we again need a regularization and for that we add two inductances in series with the resistances. The resulting stochastic dynamics is

$$\begin{aligned} L_1 \dot{I}_1 &= E - R_1 I_1 + U_1^f \\ L_2 \dot{I}_2 &= E - R_2 I_2 + U_2^f \end{aligned} \quad (3.24)$$

The Lagrangian, the entropy production rate, its expectation, and the stationary variational functional are subsequently as follows:

$$\begin{aligned} 4\mathcal{L} &= \frac{\beta_1}{R_1} (L_1 \dot{I}_1 + R_1 I_1 - E)^2 + \frac{\beta_2}{R_2} (L_2 \dot{I}_2 + R_2 I_2 - E)^2 \\ \dot{S}(I_1, I_2; \dot{I}_1; \dot{I}_2) &= \beta_1 I_1 (E - L_1 \dot{I}_1) + \beta_2 I_2 (E - L_2 \dot{I}_2) \\ \sigma(I_1, I_2) &= \beta_1 R_1 I_1^2 + \beta_2 R_2 I_2^2 \\ 4\mathcal{J}(I_1, I_2) &= \sigma(I_1, I_2) - 2\dot{S}(I_1, I_2, 0, 0) + \beta_1 \frac{E^2}{R_1} + \beta_2 \frac{E^2}{R_2} \end{aligned} \quad (3.25)$$

If $\beta_1 = \beta_2 + \epsilon$, minimizing the rate function \mathcal{J} results in minimizing $\sigma(I_1, I_2) - 2\beta E(I_1 + I_2)$ up to order ϵ . Note that this splits into two independent variational problems for I_1 respectively I_2 which comes as no surprise: the two currents are entirely dynamically decoupled. Yet, one can again formulate a single MaxEP principle in this case: the stationary currents are obtained by maximizing the expected entropy production rate σ under the constraint $\sigma(I_1, I_2) = \beta E(I_1 + I_2)$, the right hand side being just the total power input. This formulation is equivalent with the MaxEP principle in [21]. Analogous remarks as in Section 3.2 apply here.

4. CONCLUSIONS

Fluctuation theory naturally identifies the specific structure of dynamical fluctuations as the underlying reason for the (variational) entropy production principles as well as their validity conditions and limitations; just as the equilibrium fluctuation theory explains the maximum entropy principle and its derivations. It also provides a natural and systematic way how to search for new variational principles beyond trial-and-error methods, not available within pure thermodynamics.

We summarize our findings within that more general perspective:

- Both MinEP and MaxEP principles have various forms (for hydrodynamic models in local equilibrium, for discrete networks, for various types of Markov processes,...), but there is no essential difference between them up to the crucial restriction to the close-to-equilibrium regime. All attempts for their exact justification beyond the linear regime are highly doubtful. In particular, thermodynamics itself has little to say here about possible generalizations except via some trial-and-error methods. We expect that dynamical fluctuation theory will present a more systematic avenue for evaluating nonequilibrium behavior via variational methods.
- There is no fundamental difference between the nature and validity of the MinEP and the MaxEP principles. Which one is to be used depends on the choice of thermodynamic variables, whether they are symmetric or antisymmetric with respect to time-reversal. That clear observation is a first concrete result that the fluctuation/statistical approach provides.
- The set-up in the pioneering works of Prigogine [19] concerning MinEP typically refers to some canonical thermodynamic structure. Yet, it is useful to broaden the view on these variational principles; the MinEP principle is valid for mesoscopic systems (Markovian, both with discrete and with continuous

state space) where one does not *a priori* recognize some canonical structure as is usually written in terms of forces and currents.

Acknowledgment

K. N. is grateful to the Instituut voor Theoretische Fysica, K. U. Leuven for kind hospitality. He also acknowledges the support from the Grant Agency of the Czech Republic (Grant no. 202/07/0404). C. M. benefits from the Belgian Interuniversity Attraction Poles Programme P6/02.

REFERENCES

- [1] L. Bertini, A. De Sole, D. Gabrielli, G. Jona-Lasinio and C. Landim, Minimum dissipation principle in stationary non equilibrium states, *J. Stat. Phys.* **116**: 831 (2004).
- [2] S. Bruers, Classification and discussion of macroscopic entropy production principles. arXiv:cond-mat/0604482.
- [3] A. Dembo and O. Zeitouni. *Large Deviation Techniques and Applications*. Jones and Barlett Publishers, Boston (1993).
- [4] B. Derrida, Non equilibrium steady states: fluctuations and large deviations of the density and of the current, arXiv:cond-mat/0703762v1.
- [5] M. D. Donsker, S. R. Varadhan, Asymptotic evaluation of certain Markov process expectations for large time, I. *Comm. Pure Appl. Math.*, **28**:1 (1975).
- [6] S. R. de Groot, P. Mazur. *Non-equilibrium Thermodynamics*. North Holland Publishing Company (1969).
- [7] A. Hjelmfelt and J. Ross, Thermodynamic and stochastic theory of electrical circuits, *Phys. Rev. A*, **45**:2201 (1992).
- [8] E. T. Jaynes, The minimum entropy production principle, *Ann. Rev. Phys. Chem.*, **31**:579–601 (1980).
- [9] A. N. Jordan, E. V. Suhorukov and S. Pilgram, Fluctuation statistics in networks: a stochastic path integral approach, *J. Math. Phys.*, **45**:4386 (2004).
- [10] R. Landauer, Inadequacy of entropy and entropy derivatives in characterizing the steady state, *Phys. Rev. A*, **12**:636–638 (1975).
- [11] R. Landauer, Stability and entropy production in electrical circuits, *J. Stat. Phys.*, **13**:1–16 (1975).
- [12] R. Landauer, Statistical physics of machinery: forgotten middle-ground, *Physica A*, **194**:551–562 (1993).
- [13] C. Maes, On the origin and the use of fluctuation relations for the entropy. *Séminaire Poincaré*, **2**:29–62, Eds. J. Dalibard, B. Duplantier and V. Rivasseau, Birkhäuser, Basel (2003).
- [14] C. Maes and K. Netočný, Time-reversal and entropy. *J. Stat. Phys.*, **110**:269–310 (2003).
- [15] C. Maes and K. Netočný, Static and Dynamical Nonequilibrium Fluctuations, arXiv:cond-mat/0612525.
- [16] C. Maes and K. Netočný, Minimum entropy production principle from a dynamical fluctuation law, arXiv:math-ph/0612063.
- [17] L. M. Martyushev, A. S. Nazarova, and V. D. Seleznev, On the problem of the minimum entropy production in the nonequilibrium stationary state, *J. Phys. A: Math. Theor.*, **40**: 371-380 (2007).

- [18] L. Onsager and S. Machlup, Fluctuations and irreversible processes. *Phys. Rev.*, **91**:1505–1512 (1951).
- [19] I. Prigogine, *Introduction to Non-Equilibrium Thermodynamics*, Wiley-Interscience, New York (1962).
- [20] H. Ziegler, *An Introduction to Thermomechanics*, North-Holland, Amsterdam (1983).
- [21] P. Županović, D. Juretić and S. Botrić, Kirchhoff's loop law and the maximum entropy production principle, *Phys. Rev. E*, **70**:056108 (2004).