

Coulomb-blockade-induced bound quasiparticle states in a double-island qubit

D. A. Pesin and A. V. Andreev

Physics Department, University of Colorado, Boulder, CO 80309

(Dated: November 10, 2018)

We study the low temperature thermodynamic properties of a superconducting double-island qubit. For an odd number of electrons in the device, the ground state corresponds to the intrinsic quasiparticle bound to the tunneling contact. The ground state is separated from the continuum of excited states by a finite gap of order of the Josephson energy E_J . The presence of the bound quasiparticle state results in a nonmonotonic temperature dependence of the width of the transition region between Coulomb blockade plateaus. The minimum width occurs at the ionization temperature of the bound state, $T_i \sim E_J / \ln(\sqrt{\Delta E_J} / \delta)$, with Δ and δ being respectively the superconducting gap and single particle mean level spacing in the island. For an even number of electrons in the system, we show that the Coulomb enhancement of the Josephson energy can be significantly stronger than that in the case of a single grain coupled to a superconducting lead. If the electrostatic energy favors a single broken Cooper pair, the resulting quasiparticles are bound to the contact with an energy that is exponentially small in the inverse dimensionless conductance.

PACS numbers: 73.23.Hk, 74.50.+r, 85.35.Gv

Some of the most promising qubit realizations are based on superconducting nanodevices [1, 2, 3, 4, 5, 6]. These include charge [1, 2, 3, 4, 5] and phase [6] qubits. A charge qubit consists of a small superconducting island coupled by a tunneling contact either to another superconducting grain or a bulk superconducting lead. At low temperatures quantum fluctuations of the island charge strongly influence the properties of such devices.

We study the effect of quantum charge fluctuations on the thermodynamic properties of a double-island qubit [4, 5]. The device is schematically depicted in Fig. 1. It consists of two superconducting islands coupled to each other by a tunnelling contact and capacitively coupled to external gates. In a typical experimental realization the probability of electron tunneling between the qubit and the surrounding environment on the experimental time scale is negligible. Accordingly we consider the total number of electrons in the device to be fixed [7]. This number may either be even or odd and can be randomly changed by heating the device.

In the absence of tunnelling between the grains the

electron number on each island is quantized and changes abruptly at the charge degeneracy lines in the V_{g1} - V_{g2} plane. Depending on the values of the pairing gap and the charging energy electrons can be transferred between in the islands either one by one or in pairs. At finite tunnelling between the grains quantum charge fluctuations lead to rounding of Coulomb blockade steps in the voltage dependence of the island charge. This phenomenon was studied theoretically [8, 9, 10, 11, 12] and experimentally [13] for different single electron devices.

In this paper we determine the gate voltage dependence of the island charge for a double-island qubit. We also study the Coulomb enhancement of the energy of Josephson coupling between the grains. For a fixed total number of electrons in the qubit the Hamiltonian of the system can be written as

$$H = H_C + H_t + H_0, \quad (1a)$$

$$H_C = E_C(\hat{n} - N)^2, \quad (1b)$$

$$H_t = \sum_{kp\sigma} t_{kp} a_{k,\sigma}^\dagger a_{p,\sigma} + h.c., \quad (1c)$$

where t_{kp} are the tunneling matrix elements, $\sigma = \pm 1$ is the spin index, and $a_{p/k,\sigma}$ is the annihilation operator for an electron in state k, σ in the left island or state p, σ in the right island respectively. The operator of the electron number difference (in units of electron charge) between the left and right islands is denoted by \hat{n} , E_C is the corresponding charging energy, and the dimensionless parameter N is given by the appropriate linear combination of the voltages on the left and right gates. Finally, H_0 denotes the Hamiltonian of the two grains in the absence of tunneling and charging interaction. For simplicity we consider H_0 to be of the BCS form and assume that both islands have identical pairing gaps, Δ , and single particle mean level spacings, δ .

We assume that $\langle |t_{kp}|^2 \rangle_{kp} / \delta^2 \ll 1$, where $\langle \dots \rangle_{kp}$ denotes averaging over the Fermi surfaces of both islands. Then the dimensionless conductance $g = \frac{h}{e^2 R} =$

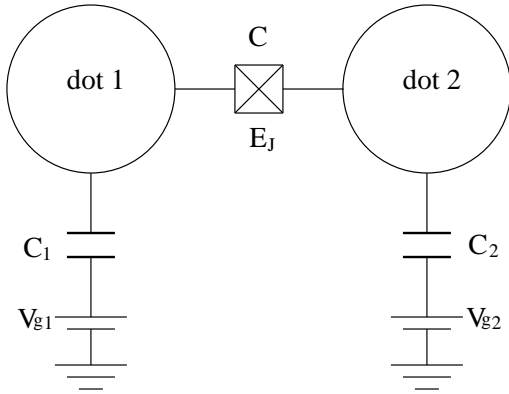

FIG. 1: The two islands of the qubit are coupled to the gates which are maintained at the voltages V_{g1} and V_{g2} .

$8\pi^2 \frac{\langle |t_{kp}|^2 \rangle_{kp}}{\delta^2}$ of the tunneling contact, with R being its normal state resistance, obeys the condition $g \ll 8\pi^2$. Further, we restrict our analysis to low temperatures, $T < T^* = \Delta / \ln(\Delta/\delta)$, where no thermal quasiparticles are present [14].

First we consider the case of an odd number of electrons in the device. To be specific we assume it to be equal to unity and study the gate voltage dependence of the average island charge difference $\langle \hat{n} \rangle$ for $|N| \ll 1$. In this regime the charge states with $n = \pm 1$ are nearly degenerate and quantum charge fluctuations are strong.

In the absence of tunneling the eigenstates of the Hamiltonian, Eq. (1) are characterized by n and the momenta and spins of the quasiparticles present in the islands. For an odd number of electrons there is precisely one quasiparticle in the qubit at $T < T^*$. We denote the states with $n = 1$ and the quasiparticle in state k, σ in the left island by $|k, \sigma; 0\rangle$ and those with $n = -1$ and the quasiparticle in state p, σ in the right island by $|0; p, \sigma\rangle$.

For weak tunneling the most straightforward way to proceed is to use perturbation theory. In second order in tunneling scattering matrix elements between states $|0; p, \sigma\rangle$ and $|0; p', \sigma\rangle$, and $|k, \sigma; 0\rangle$ and $|k', \sigma; 0\rangle$, appear.

Their magnitude $\sim \frac{\langle |t_{kp}|^2 \rangle_{kp}}{\delta} \sqrt{\frac{\Delta}{E_C N}}$ significantly exceeds the energy distance between such states, $\sim \delta^2/\Delta$, even far from the charge degeneracy point. Thus in contrast to the case of a normal grain [8] virtual tunneling processes strongly mix different quasiparticle states even for $\langle |t_{kp}|^2 \rangle_{kp}/\delta^2 \ll 1$. For $|N| \ll 1$ only the two nearly degenerate charge states need be considered. In the spirit of degenerate perturbation theory [15] we look for the ground state wave function in the form of a linear combination of low energy states

$$|\Psi\rangle = \sum_{p,\sigma} C_{p,\sigma} |0; p, \sigma\rangle + \sum_{k,\sigma} C_{k,\sigma} |k, \sigma; 0\rangle. \quad (2)$$

We rewrite the tunneling Hamiltonian (1c) in terms of the quasiparticle creation and annihilation operators with the aid of the Bogolubov transformation $a_{p(k),\sigma} = u_{p(k)}\alpha_{p(k),\sigma} + \sigma v_{p(k)}\alpha_{-p(k),-\sigma}^\dagger$ (here $u_{p(k)}$ and $v_{p(k)}$ are the standard BCS coherence factors) and project it onto the subspace of low energy states given by Eq. (2). The energy spectrum of the resulting problem can be determined exactly. The density of states in the continuum is unaffected by the presence of tunneling. In addition to the continuum states one bound state below the continuum appears. Though its wave function, Eq. (2), depends on the specific form of the tunneling matrix elements t_{kp} its energy in the weak tunneling approximation can be expressed in terms of the dimensionless conductance of the tunneling contact, g . We obtain for the ground state energy

$$E_0(N) = E_C(1 + N^2) + \Delta - \sqrt{4E_C^2 N^2 + E_J^2}, \quad (3)$$

where $E_J = g\Delta/8$ is the Ambegaokar-Baratoff [16] expression for the Josephson energy. The binding energy,

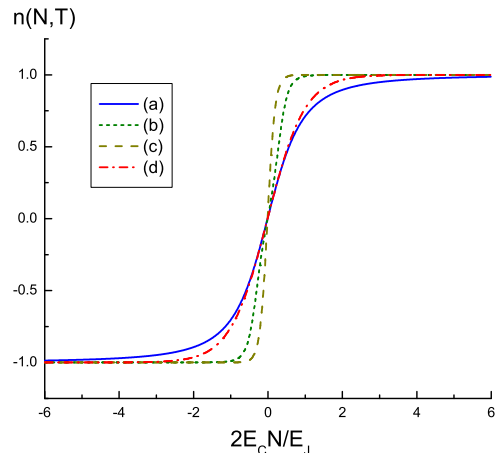

FIG. 2: The dependence of the island charge difference on the rescaled gate voltage $2E_C N/E_J$ for temperatures $T = 0$ (a), $T = 0.08E_J$ (b), $T = 0.2E_J$ (c), $T = E_J$ (d). The temperature dependence of the step width is clearly non-monotonic.

i.e. the gap between the bound state energy and the bottom of the continuum is given by

$$\epsilon_B = E_J \left(-|\tilde{N}| + \sqrt{\tilde{N}^2 + 1} \right), \quad (4)$$

where we introduced a rescaled gate voltage $\tilde{N} = \frac{2E_C}{E_J} N$.

Using the obtained energy spectrum we calculate the free energy F and find the gate voltage dependence of the island charge difference $n(N, T) = \langle \hat{n} \rangle = -\frac{1}{2E_C} \frac{\partial F}{\partial N} + N$, where $\langle \dots \rangle$ denotes the thermodynamic average. The results are conveniently expressed in terms of the rescaled temperature $\tilde{T} = T/E_J$, binding energy $\tilde{\epsilon}_B = \epsilon_B/E_J$ and gate voltage \tilde{N} . Denoting the zero temperature result by $n(N, 0) = n_0(\tilde{N})$,

$$n_0(\tilde{N}) = \frac{\tilde{N}}{\sqrt{\tilde{N}^2 + 1}}, \quad (5)$$

we can express the island charge difference as

$$n(N, T) = \frac{2 \sinh\left(\frac{\tilde{N}}{\tilde{T}}\right) e^{-|\tilde{N}|/\tilde{T}} + n_0(\tilde{N}) e^{\tilde{\epsilon}_B/\tilde{T} - \alpha}}{2 \cosh\left(\frac{\tilde{N}}{\tilde{T}}\right) e^{-|\tilde{N}|/\tilde{T}} + e^{\tilde{\epsilon}_B/\tilde{T} - \alpha}}. \quad (6)$$

Here we introduced the notation $\alpha = \frac{1}{2} \ln \frac{8\pi\Delta E_J \tilde{T}}{\delta^2}$.

The gate voltage dependence of the island charge is plotted in Fig. 2 for several temperatures and typical experimental parameters [4], $\Delta \approx 2K$, $g \approx 1$, $\delta \approx 10^{-4}K$. Remarkably, the temperature dependence of the step width is non-monotonic and shows a minimum at the ionization temperature of the bound state $T_i \sim E_J/\alpha$. Qualitatively, the non-monotonic temperature dependence of the step width can be understood as follows. At $T < T_i$ the quasiparticle resides predominantly in the bound

state, and the width of the step is determined by the binding energy, $\delta N \sim E_J/E_C$. At $T > T_i$ the quasiparticles reside in the continuum, and the width of the step is determined by the temperature, $\delta N \sim T/E_C$. Since according to the Saha rule the ionization temperature T_i is smaller than the binding energy E_J the temperature dependence of the step width is nonmonotonic.

We now turn to the case of an even number of electrons in the device, which we take to be 2 to be specific. For brevity we set $T = 0$ from here on.

First we study the dependence of the strength of the Josephson coupling between the grains on $\Delta - 2E_C$ for $\Delta > 2E_C$. We consider the vicinity of the degeneracy point ($|N| \ll 1$) between the two charge states, $n = \pm 2$, with one extra Cooper pair in the system. For $\Delta > 2E_C$ the energies of these two states lie below the bottom of the continuum of states with $n = 0$ and one quasiparticle in each island, see Fig 3.

For $\Delta - 2E_C$ sufficiently large the Josephson energy can be obtained from perturbation theory in tunneling [17]:

$$\tilde{E}_J = E_J \frac{4}{\pi^2} \int_0^\infty \frac{d\xi_k}{\varepsilon_k} \int_0^\infty \frac{d\xi_p}{\varepsilon_p} \frac{\Delta}{(\varepsilon_k + \varepsilon_p - 4E_C)}, \quad (7)$$

where $\varepsilon_{k(p)} = \sqrt{\xi_{k(p)}^2 + \Delta^2}$.

At $\Delta \rightarrow 2E_C$ the integral in Eq. (7) diverges logarithmically. This divergence arises from tunneling through the states of the continuum with $\xi_{k(p)} \ll \Delta$. These states become strongly hybridized with the two discrete states with $n = \pm 2$. To find the Josephson energy with logarithmic accuracy we look for the wave function in the form of a linear combination of the low energy states,

$$|\Psi\rangle = \Psi_{20}|2,0\rangle + \Psi_{02}|0,2\rangle + \sum_{k,p,\sigma} C_{p,k,\sigma}|k,\sigma;p,-\sigma\rangle. \quad (8)$$

Here $|2,0\rangle$ and $|0,2\rangle$ denote the states with $n = 2$ and $n = -2$ respectively, and $|k,\sigma;p,-\sigma\rangle$ denotes the $n = 0$ state with quasiparticles in state k, σ in the left dot and $p, -\sigma$ in the right one. Solving the Schrödinger equation with this wavefunction is straightforward. The continuum spectrum is unaffected by the presence of tunneling. The energies E of discrete spectrum can be found from the equation

$$E = \frac{E_{20} + E_{02}}{2} + \frac{\pi(E - E_{20})(E - E_{02})}{8E_J \ln \frac{E_{11} + 2\Delta - E}{E_{11} + 3\Delta - E}}. \quad (9)$$

Here $E_{11} = E_C N^2$ is the electrostatic energy of the $|k,\sigma;p,-\sigma\rangle$ states, and $E_{20(02)} = E_C(2 \mp N)^2$ are those of the $|2,0\rangle$ and $|0,2\rangle$ states respectively. For $\Delta > 2E_C$ this equation has two solutions. The Josephson energy \tilde{E}_J is given by the energy splitting between these states at the degeneracy point $N = 0$,

$$\tilde{E}_J = \frac{8}{\pi} E_J \ln \frac{\Delta}{\max\{E_J, \Delta - 2E_C\}}, \quad (10)$$

where E_J is the Ambegaokar-Baratoff expression for the Josephson energy defined below Eq. (3).

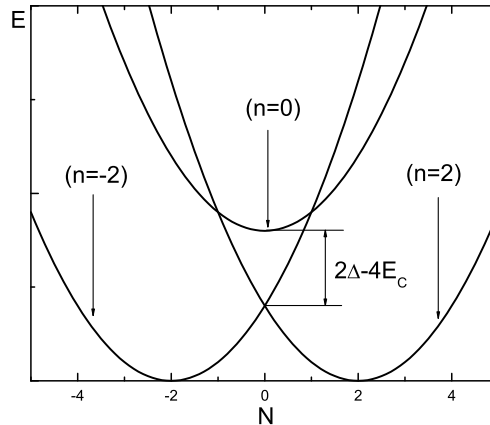

FIG. 3: Energy diagram for the Josephson energy calculation. Electrostatic energies of the relevant charge states are plotted as a function of N . The states with $n = \pm 2$ are coupled by tunneling via the continuum of states with $n = 0$.

For $E_J < \Delta - 2E_C \ll \Delta$ this expression reproduces the logarithmic asymptotic of the perturbative result (7). For $0 < \Delta - 2E_C \lesssim E_J$ perturbation theory breaks down and the Coulomb enhancement factor of the Josephson energy saturates for small g at the value

$$\frac{\tilde{E}_J}{E_J} = \frac{8}{\pi} \ln \frac{8}{g}. \quad (11)$$

Equation (10) shows that the Coulomb enhancement factor of the Josephson energy in a double-island qubit can be much larger than that for a single grain connected to a bulk lead [17, 18], which cannot exceed 1.3. This agrees with the recent experimental observation of an enhancement by a factor of ~ 3 in double-island qubits [4].

For $\Delta - 2E_C < 0$ the discrete level with the higher energy disappears as a result of merging with the continuum, whereas the lower level continues to be separated by a finite gap from the continuum and represents the ground state of the system. The gate voltage dependence of its energy, which can in principle be obtained by solving Eq. (9), determines the island charge difference at zero temperature, $n(N, 0)$.

For $-E_J \lesssim \Delta - 2E_C < 0$ the gap between the ground state and the bottom of the continuum is of order E_J . The gate voltage dependence of the ground state energy and the island charge remain qualitatively the same as those for $\Delta - 2E_C > 0$. In particular, the charge plateaus with $n = \pm 2$ are joined by a smooth curve that lacks an intermediate plateau at $n = 0$.

If Δ decreases even further, $\Delta - 2E_C < -E_J$, the island charge difference develops a plateau, $n(N, 0) \approx 0$ for $|N| < 1 - \Delta/2E_C$. In this regime the ground state corresponds to a bound state of two quasiparticles, one in each island, with the gap between the ground state and

the bottom of the continuum being exponentially small, $E_{11} + 2\Delta - E \approx \Delta \exp\left(-\frac{\pi(E_{20}-E_{11})(E_{02}-E_{11})}{4E_J(E_{20}+E_{20}-2E_{11})}\right)$. Near the charge degeneracy points $N_{\pm} = \pm\left(1 - \frac{\Delta}{2E_C}\right)$ between the states with $n = 0$ and $n = \pm 2$ Eq. (9) simplifies. As a result the island charge difference can be found from the implicit relation,

$$\frac{n}{2-n} + \ln \frac{n}{(2-n)} = \frac{\pi N^*}{2} + \ln \frac{2\pi}{g}. \quad (12)$$

Here we assumed N to be positive and denoted by $N^* = \frac{2E_C}{E_J}\left(N - 1 + \frac{\Delta}{2E_C}\right)$ a rescaled gate voltage distance from the charge degeneracy point. For $N < 0$ the island charge difference can be obtained by noting that n is an odd function of N . Away from the charge degeneracy point, i.e. for $|N^*| \gg 1$, we obtain the approximate expressions for the island charge difference: $n = \frac{4\pi}{g} \exp\left(-\frac{\pi|N^*|}{2}\right)$ for $N^* < 0$, and $n = 2 - \frac{4}{\pi N^*}$ for $N^* > 0$.

In summary, we have studied the low temperature thermodynamic properties of a double-island qubit in the limit of the vanishing single particle mean level spacing. We have shown that the ground state of the system is always separated from the continuum of excited states by a finite gap, and determined the gate voltage dependence of the island charge.

For an odd number of electrons in the device the ground state corresponds to a bound state of the intrinsic quasiparticle. The binding energy of this state is given by Eq. (4). It attains its biggest value given by the Josephson energy E_J at the charge degeneracy point. The gate voltage dependence of the island charge is given by Eqs. (5) and (6). The presence of the bound state leads to a non-monotonic temperature dependence of the width of the Coulomb blockade step. The minimal

width is achieved at the ionization temperature of the bound quasiparticle state $T_i \sim E_J / \left(\frac{1}{2} \ln \frac{8\pi\Delta E_J}{\delta^2}\right)$.

For an even number of electrons the gate voltage dependence of the ground state energy and the island charge difference are determined by Eqs. (9) and (12) respectively. For $\Delta < 2E_C$ and $|N| < 1 - \Delta/2E_C$ the two intrinsic quasiparticles are bound to the tunneling contact. The binding energy is exponentially small, see discussion above Eq. (12). For $\Delta > 2E_C$ the Coulomb stimulation of the Josephson energy in the double-island system can significantly exceed that for a single grain coupled to a bulk electrode, see Eqs. (10) and (11). This is in agreement with the experimental findings of Ref. [4].

In deriving our results we neglected virtual transitions to higher energy states, such as the non-resonant charge states and states with more than one quasiparticle in the system. Such transitions lead to corrections that remain small at the charge degeneracy point and amount to renormalization of the charging energy of the system [10, 19]. Thus E_C should be understood as the renormalized charging energy.

Our results can be directly tested by sensitive charge measurements techniques that became available recently [13, 20]. The bound quasiparticle state is also present in a single superconducting grain coupled to a superconducting lead when the electrostatic energy favors an odd number of particles in the grain [21]. However in contrast to the latter case [10] the gate voltage dependence of the island charge in the double-island qubit has no discontinuity at the charge degeneracy point. This difference is due to the absence of thermal quasiparticles in the double-island system at low temperatures.

This work was supported by the NSF Grant DMR-9984002 and by the David and Lucille Packard Foundation. We are grateful to L. I. Glazman and K. W. Lehnert for fruitful discussions.

-
- [1] V. Bouchiat, D. Vion, P. Joyez, D. Esteve, and M. H. Devoret, *Phys. Scr.* **T76**, 165 (1998).
 [2] J. E. Mooij et al., *Science* **285**, 1036 (1999).
 [3] Y. Nakamura, Yu. A. Pashkin, and J. S. Tsai, *Nature (London)* **398**, 786 (1999); Y. Nakamura and J. S. Tsai, *J. of Low Temp. Physics*, **118**, 765 (2000).
 [4] E. Bibow, P. Lafarge, and L. P. Lévy, *Phys. Rev. Lett.* **88**, 017003 (2002).
 [5] A. Blais, *et al.*, *cond-mat/0402216*.
 [6] J. M. Martinis, S. Nam, J. Aumentado, and C. Urbina *Phys. Rev. Lett.* **89**, 117901 (2002)
 [7] This assumption is not true for the experiments of Ref. [4], where the two islands were coupled to two superconducting electrodes by highly resistive tunneling contacts. In this setup the total number of electrons in the qubit can be kept fixed by adjusting the pairing gap Δ and the corresponding gate voltages appropriately.
 [8] K. A. Matveev, *Sov. Phys. JETP* **72**, 892 (1991).
 [9] K. A. Matveev, *Phys. Rev. B* **51**, 1743 (1995)
 [10] K. A. Matveev and L. I. Glazman, *Phys. Rev. Lett.* **81**, 3739 (1998).
 [11] H. Schöller and G. Schön, *Phys. Rev. B* **50**, 18436 (1994).
 [12] G. Göppert *et al.*, *Phys. Rev. Lett.* **81**, 2324 (1998).
 [13] K. W. Lehnert *et al.*, *Phys. Rev. Lett.* **91**, 106801 (2003).
 [14] M. Tinkham, *Introduction to superconductivity*, (McGraw Hill, New York 1996).
 [15] L. D. Landau and E. M. Lifshitz, *Quantum mechanics*, (Butterworth-Heinemann, Oxford, 1976).
 [16] V. Ambegaokar and A. Baratoff, *Phys. Rev. Lett.* **10**, 486 (1963).
 [17] K. A. Matveev, M. Gissel-fält, L. I. Glazman, M. Jonson and R. I. Shekhter, *Phys. Rev. Lett.* **70**, 2940 (1993).
 [18] P. Joyez, P. Lafarge, A. Filipe, D. Esteve, and M. H. Devoret, *Phys. Rev. Lett.* **72**, 2458 (1994).
 [19] A. I. Larkin and Yu. N. Ovchinnikov, *Phys. Rev. B* **28**, 6281 (1983).
 [20] R. J. Schoelkopf et. al., *Science* **280**, 1238 (1998).
 [21] P. Lafarge *et al.*, *Z. Phys. B* **85**, 327 (1991).