

# The CRESST II Dark Matter Search

Leo Stodolsky<sup>1</sup>, G Angloher<sup>1</sup>, M Bauer<sup>3</sup>, I Bavykina<sup>1</sup>, A Bento<sup>1,5</sup>, C Bucci<sup>4</sup>, C Ciemniak<sup>2</sup>, G Deuter<sup>3</sup>, F v Feilitzsch<sup>2</sup>, D Hauff<sup>1</sup>, P Huff<sup>1</sup>, C Isaila<sup>2</sup>, J Jochum<sup>3</sup>, M Kiefer<sup>1</sup>, M Kimmerle<sup>3</sup>, J C Lanfranchi<sup>2</sup>, S Pfister<sup>2</sup>, F Petricca<sup>1</sup>, W Potzel<sup>2</sup>, F Pröbst<sup>1</sup>, F Reindl<sup>1</sup>, S Roth<sup>2</sup>, K Rottler<sup>3</sup>, C Sailer<sup>3</sup>, K Schöffner<sup>1</sup>, J Schmalzer<sup>1</sup>, S Scholl<sup>3</sup>, W Seidel<sup>1</sup>, M v Sivers<sup>2</sup>, C Strandhagen<sup>3</sup>, R Strauss<sup>2</sup>, A Tanzke<sup>1</sup>, I Usherov<sup>3</sup>, S Wawoczny<sup>2</sup>, M Willers<sup>2</sup> and A Zöller<sup>2</sup>

<sup>1</sup> Max-Planck-Institut für Physik, Föhringer Ring 6, D-80805 München, Germany

<sup>2</sup> Physik-Department E15, Technische Universität München, D-85747 Garching, Germany

<sup>3</sup> Eberhard-Karls-Universität Tübingen, D-72076 Tübingen, Germany

<sup>4</sup> INFN, Laboratori Nazionali del Gran Sasso, I-67010 Assergi, Italy

<sup>5</sup> CI, Physics Department, University of Coimbra, P-3004 516 Coimbra, Portugal

E-mail: les@mpp.mpg.de

**Abstract.** Direct Dark Matter detection with cryodetectors is briefly discussed, with particular mention of the possibility of the identification of the recoil nucleus. Preliminary results from the CRESST II Dark Matter search, with 730 kg-days of data, are presented. Major backgrounds and methods of identifying and dealing with them are indicated.

## 1. Introduction

CRESST II is a cryogenic Dark Matter search operating in the Gran Sasso laboratory and is a collaboration between the Max-Planck-Institute, the Technical University of Munich, the University of Tübingen, and the Laboratori Nazionali del Gran Sasso.

CRESST is distinguished by the presence of two cryogenic readout channels. One is for heat or phonons. This provides a very good measurement of the total energy of an event. The other channel is for the scintillation light produced in the target material, which is the scintillating crystal  $CaWO_4$ . This light signal is used to greatly reduce the electron-photon backgrounds. For the nuclear recoils it also provides some information on which nucleus is recoiling, which can play an important role in the analysis.

## 2. Why Cryodetectors?

The proposal to look for direct detection of dark matter was stimulated by the suggestion of using cryodetectors for weak processes [1] and it might be helpful to recall the motivation for using cryodetectors. We are looking for ‘WIMP’-induced nuclear recoils. The big problem in detecting this process is the small energy expected for the recoil.

As one sees from the example illustrated in Fig 1 with a 50 GeV WIMP, the recoil energy spectrum drops radically with energy. And the situation is even more dramatic with light WIMPs, as we see in Fig 2 with a 10 GeV WIMP.

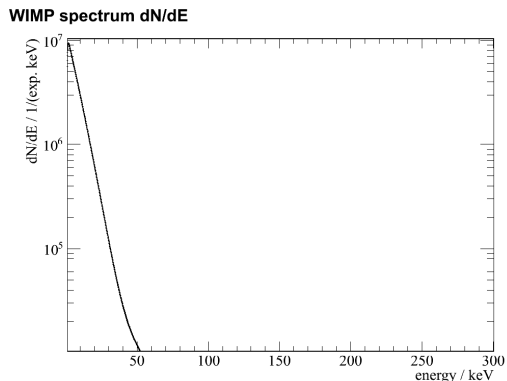

**Figure 1.** Recoil energy spectrum expected in CRESST ( $CaWO_4$ ) for a  $M=50$  GeV WIMP.

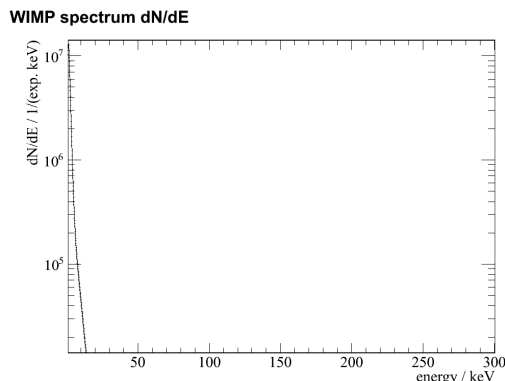

**Figure 2.** Recoil energy spectrum expected in CRESST ( $CaWO_4$ ) for a  $M=10$  GeV WIMP.

It is evident that an optimal dark matter detector should be able to see and resolve small ( $\leq keV$ ) energies. However, most classical particle detection methods are barely able to get down to this range, and when employed for dark matter detection are operating on the ragged edge of their capabilities. For this reason many detector projects, not employing low temperatures, are effectively operating way out on the tail of the distributions, or in a regime where a special understanding of the detector is necessary. This difficulty, as we see from the figures, is especially present for light WIMPs.

### 2.1. Energy Threshold and Resolution

On the other hand cryodetectors are well adapted to this problem. The reason may be understood in terms of energy scales [2]. In conventional detectors, whether using liquids, gases, or solid state devices, via ionization or scintillation, the detection process starts by activating or ejecting an electron in some way. As is familiar from atomic or solid state physics, the energy unit for such processes is the electron volt. On the other hand with cryo-devices we are dealing with much smaller energies. For superconductivity for example, the typical energy unit is the energy to break a Cooper pair, which is  $\sim 1^\circ K \sim 10^{-4}eV$  for classical superconductors and can be even less, as for the tungsten thermometers in CRESST. Thus one has considerably more and finer excitations for our few keV, implying a much higher accuracy in the final measurement.

Fig 3 shows the principle of a CRESST detector. A superconducting film thermometer, held at the superconducting-normal transition, has a resistance which is sensitive to very small temperature changes  $\Delta T$ . These changes are read out by Squid electronics as in Fig 4.

The beautiful energy resolution of these detectors is illustrated [3] in Fig 5. One notes, around 46 KeV, the onset of a  $\gamma - \beta$  feature due to the presence of a small  $^{210}Pb$  impurity. This onset is very sharp, showing the fine energy resolution. The other features of the spectrum are also understood.

There are two points to be noted here. One is the low energy *threshold*, which allows one to get down to the main part of the expected recoil energy spectrum. Secondly, there is the very good energy *resolution*. It will be appreciated from Figs 1 and 2 that, due to the very rapid variation with energy, even a small error in an energy determination can lead to a very big error in the rate to be expected. Thus even in the absence of a positive signal, where we are just setting upper limits, a good understanding of the energy resolution is necessary to quantitatively determine what WIMP parameters are being excluded. This is especially true for light WIMPs.

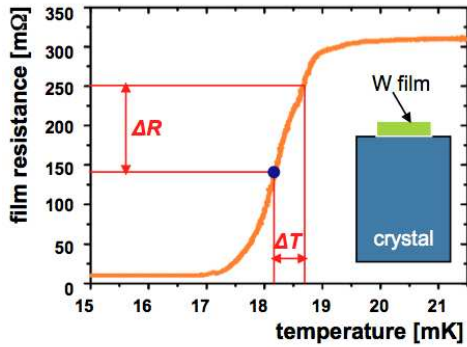

**Figure 3.** Principle of a CRESST detector with a superconducting thermometer deposited on a crystal ( $\text{CaWO}_4$ ).

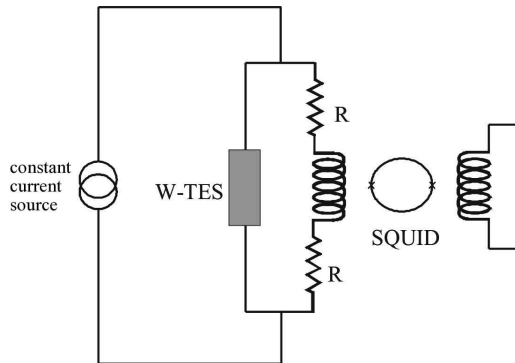

**Figure 4.** Readout circuit for the superconducting thermometer (TES).

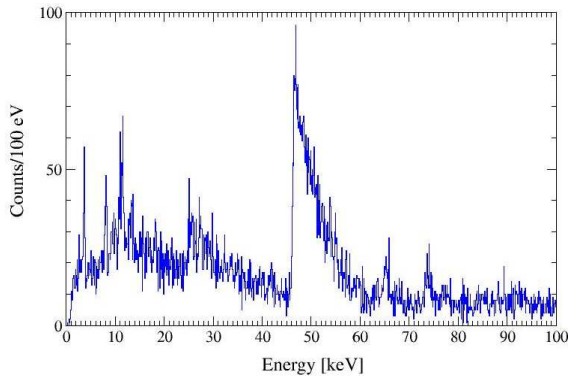

**Figure 5.** Spectrum from a CRESST detector illustrating the very good energy resolution, as exhibited by the features due to small impurities.

## 2.2. Multi-element targets

There is another advantage to cryodetectors. The cryo-technique is well adapted to studying different nuclear targets at the same time; that is, in parallel in the same setup. For example, in CRESST we have oxygen, calcium, and tungsten nuclei present simultaneously and their recoils are read out at the same time by the same system. In addition, the superconducting thermometer, or perhaps another cryo-sensor, can be applied onto various materials. These features are in strong contrast to detectors using only one element, such as a noble gas or liquid, which are designed around the properties of that one element. While such detectors have certain advantages, the multi-target aspect is definitely missing.

This ability to compare different nuclei gives valuable extra information and could play an important role in verifying a positive signal. Given the suggestion of a positive signal, there will always be the suspicion that it is due to some unsuspected background, and this fear may not be unfounded, given the very low rates involved and the rather unspecific nature of the WIMP signal. It would therefore be very helpful to have some features of the data which are characteristic of the sought-for WIMP signal.

A good, and one of the few, possibilities for something characteristic would be the comparison of the properties of the signal on different nuclei. This should vary in a definite way as we look at different nuclei, something not in general true for most backgrounds.

*2.2.1. Recoil Spectrum* One of the simplest features concerns the shape of the recoil energy spectrum. Since the incoming WIMP flux is evidently the same for all our target nuclei, the shape of the recoil energy spectrum should vary in a well defined way from nucleus to nucleus. This shape is just given by the mass and velocity spectrum of the incoming WIMPs, which is the same for all nuclei, and the mass and form factor of the nucleus. In addition to the mass, the form factor is the only quantity varying with the nucleus. It is however, a well known quantity, and for the small recoils where most of the rate is concentrated, depends on only one parameter, the radius of the nucleus.

Thus the shape of the recoil spectra on different nuclei should be in agreement with each other, once a mass for the WIMP is assumed, and observation of the correct behavior would go a long way towards making a WIMP signal convincing.

We stress the shape of the recoil spectrum and not its absolute level or total rate. The absolute rate can of course vary from nucleus to nucleus, depending on the quantum numbers of the WIMP and the number of neutrons and protons in the nucleus, and whether we have coherent or spin-dependent interactions. In fact such absolute variations could be used to disentangle the composition of the WIMP[5]. But the shape is governed by the simple factors just mentioned.

### *2.3. Annual variation*

Similarly the annual variation effect[6], coming from the different velocities the earth has with respect to the galactic halo in summer and winter, is due to a simple variation of the incoming flux and should be essentially the same for all nuclei. Thus here also the observation of the same percentage variation on the different nuclei of a target material would help greatly in establishing the effect.

### *2.4. Fast neutrons*

A particular difficulty would be a fast neutron background. Fast neutrons would induce a recoil spectrum like that from the nuclear form factor. And if an annual variation effect is due to fast neutrons created by cosmic muons, these would also show the same relative variation for different nuclei. However—and here we again see the advantage of being able to distinguish which nucleus is recoiling—fast neutrons undergo diffraction scattering and diffraction scattering shows a characteristic variation from one nucleus to another, different from that expected for WIMPs. This is discussed in ref [4] and in table 1 we illustrate the point by showing for different nuclei the rate, relative to that on oxygen, for coherently scattering WIMPs and for diffractively scattering neutrons. One notes different patterns in the variation with nucleus. This could be used to distinguish WIMPs from neutrons.

## 3. The Light Channel

In CRESST, information about the nature of the recoil is obtained via the scintillation light, the “light channel”. Fig 6 shows a module with the target crystal and light detector, all surrounded by a reflecting and scintillating foil.

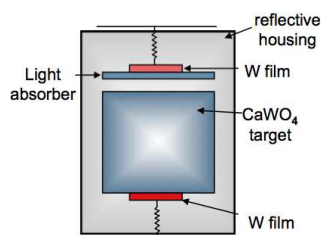

**Figure 6.** A module with main detector and light detector, surrounded by a reflecting and scintillating housing.

**Table 1.** The differential scattering rate on various nuclei in the diffractive ‘black disc’ limit, at  $E_r = 20$  keV and  $E_r = 30$  keV. The same rate for a coherently scattering WIMP at  $E_r = 20$  keV for masses 10 and 50 GeV is also shown. One notes different patterns of A behavior for neutrons and WIMPs. All values are per nucleus and normalized to that for oxygen. From ref [4].

<i>Element</i>	<i>A</i>	neutron $E_r = 20$ keV	neutron $E_r = 30$ keV	WIMP M=10 GeV	WIMP M=50 GeV
O	16	1	1	1	1
F	19	1.5	1.5	1.3	1.8
Na	23	2.2	2.2	1.6	3.3
Si	28	3.4	3.3	1.8	6.7
Ar	40	7.0	6.4	1.1	19
Ca	40	7.0	6.4	1.1	19
Ge	74	19	13	$\sim 0$	93
I	127	20	5.1	$\sim 0$	200
Xe	132	18	3.9	$\sim 0$	240
W	184	2.6	1.6	$\sim 0$	230

The distinction as to the type of recoil particle is based on the fact that the ratio (light output/energy of the event) is high for fast, light, particles and low for slow, heavy, particles. This distinction is quantified in term of the ‘‘quenching factor’’, QF, which is defined as the ratio of the light output from a given nucleus to that for an electron of the same energy. The QF has been extensively studied by the CRESST collaboration, with the values  $QF_\alpha \approx 0.22$ ,  $QF_O \approx 0.10$ ,  $QF_{Ca} \approx 0.064$ ,  $QF_W \approx 0.040$ , in  $CaWO_4$ . There are in general large fluctuations around these average values, as one sees in the plots below. Events from a run are plotted in the (energy, light yield) plane, where ‘light yield’ is defined as the light output relative to that for 122 keV photons from a  $^{57}Co$  source used for calibration.

First of all, the light channel is used to separate the very large electron-photon background from nuclear recoils. This seems to work quite well, as we illustrate by comparing a run with a neutron test source Fig 7, and a run without the test source Fig 8, from ref [3]. One sees that in the latter the neutron-induced nuclear recoils have disappeared. WIMP candidates will thus appear on such plots as events with low energy and low light yield.

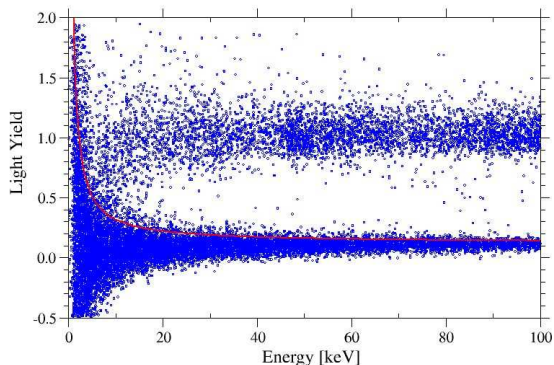

**Figure 7.** Events in the light yield-energy plane with a neutron source present. Two bands are seen, one for  $e/\gamma$  events, the other for neutron-induced nuclear recoils.

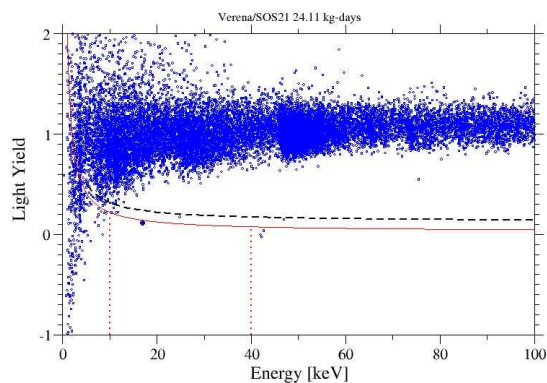
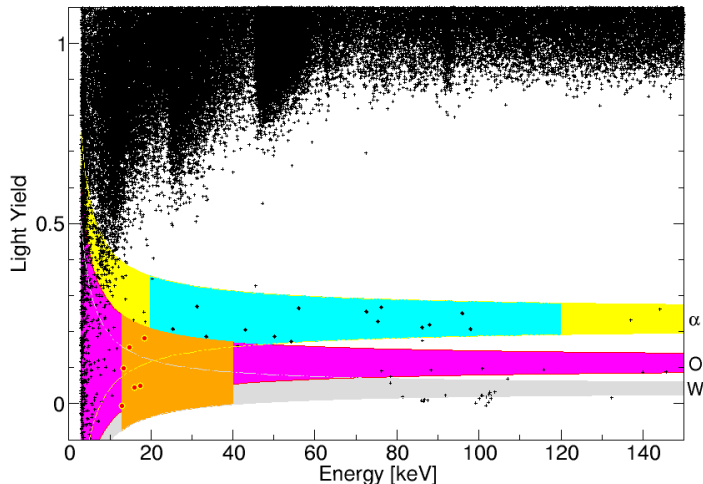

**Figure 8.** The same with the neutron source removed. The lower band is now absent. The event marked with a larger dot would be a WIMP candidate. ‘Light yield’ is defined as the light output relative to that for a 122 keV photon in the same detector.

With the present detectors, the separation of the recoils of the different nuclei from each other is not as clear as it is for the  $e - \gamma$  band. Since the QF get small, there is little light and the separation becomes difficult at low energy.

#### 4. Results from 730 kg-days

In the data analysis of a dark matter run an acceptance region at low energy and light yield is defined. This is shown for one module in Fig 9. The lower boundary in energy is set so that



**Figure 9.** Events in the light yield-energy plane from one of the modules from a long dark matter run, with a total of 730 kg-days for all 8 modules. The acceptance region for WIMP scattering candidates is colored orange and for this module contains 6 events (red dots). Also shown are the expected (90%) bands for  $\alpha$ 's, and oxygen and tungsten nuclei. The calcium band is not shown but is included in the analysis.

only one “leakage” event from the  $e - \gamma$  band is expected; the upper boundary is set at 40 keV, where according to calculations as in Fig 1, negligible WIMP rates are expected. The boundaries in light yield are chosen to include oxygen, calcium, and tungsten recoils. In all, from eight modules, the acceptance regions are found to contain 67 events.

#### 5. Background

The question then is: can all the events in the acceptance regions can be explained as background? Three forms of background are evident in Fig 9. First there is the “leakage” from the  $e - \gamma$  band, whose expected value has been used to set the lower boundary of the acceptance region. Secondly and thirdly there are  $\alpha$ 's and  $Pb$  ions from the decay  $^{210}Po \rightarrow ^{206}Pb (103 keV) + \alpha (5.3 MeV)$ . We believe these originate in the clamps holding the crystals. The  $\alpha$ 's and  $Pb$  ions can lose energy on their way out of the clamps and so possibly ‘leak’ down into the acceptance region. The probability of this occurring can be estimated by taking the observed events outside the acceptance region and extrapolating into the acceptance region. For example the blue region in Fig 9 is used to determine the  $\alpha$  spectrum.

Finally there is a fourth and perhaps most difficult background, one not seen on the plot: neutrons. The scattering of neutrons on nuclei can resemble that expected from WIMPs [4]. But there is one important difference. Neutrons, being strongly interacting, are expected to multiple scatter, while WIMPs, of course, should not. The neutron possibility was examined in two ways. One was with a neutron test source, as in Fig 7. The other was using the muon veto. CRESST has a muon veto used to exclude events which are in coincidence with an incoming muon. However one may also use some of these coincidences to see the effects of neutrons induced by muons. From both of these methods, the neutron source or the muon coincidences, one may determine the ratio of multiple hits in different detector modules to single hits. Given this information one may use the number of multiple hits found in the dark matter run to scale up to the number of WIMP-like single hits to be expected from neutrons. In the total dark

**Table 2.** Backgrounds and possible WIMP signal resulting from maximum likelihood fits.

	M1	M2
$e/\gamma$ -events	$8.00 \pm 0.05$	$8.00 \pm 0.05$
$\alpha$ -events	$11.5^{+2.6}_{-2.3}$	$11.2^{+2.5}_{-2.3}$
neutron events	$7.5^{+6.3}_{-5.5}$	$9.7^{+6.1}_{-5.1}$
Pb recoils	$14.8^{+5.3}_{-5.2}$	$18.7^{+4.9}_{-4.7}$
signal events	$29.4^{+8.5}_{-7.7}$	$24.2^{+8.1}_{-7.2}$
$m_\chi$ [GeV]	25.3	11.6
$\sigma_{WIMP}$ [pb]	$1.6 \cdot 10^{-6}$	$3.7 \cdot 10^{-5}$

matter run there were three events with multiple hits, which when scaled up, imply relatively few neutrons.

The sum of the estimates for the backgrounds does not appear to be able to explain all the events. In the analysis we thus also include a possible WIMP signal, assuming coherent scattering for the WIMP, as throughout. The results of an elaborate maximum likelihood analysis is shown in table 2.

The fitting procedure finds two minima M1 and M2 for the likelihood function, both of about the same strength (4.7 and 4.2  $\sigma$ ), with WIMP masses of 25 GeV and 12 GeV respectively. The WIMP cross section for M1 can be appreciably smaller than for M2 since the heavier mass allows the scattering on the tungsten to be above threshold and the coherence  $A^2$  factor has a large effect.

It must be said that maximum likelihood analyses should be appreciated with care. The analysis takes place within the context of an assumed model, and the resulting  $\sigma$ 's characterize how sharply the parameters used in the model are determined. It is thus perfectly possible to have a bad model with a good sigma. For this reason some kind of additional 'goodness of fit' characterization is needed. We have examined the "p-value" [8] which estimates how probable it is that the model parameters found from the maximum likelihood fit would give rise to the actually observed data. The value of p turns out to be the not very small 0.35, which appears acceptable.

## 6. Future Plans

Further analysis using other procedures is underway, and these may yield somewhat different results. But it is intriguing that the obvious backgrounds do not seem to entirely explain the data. To clarify the situation, a further CRESST run, in which it is hoped there will be substantially reduced backgrounds, is in preparation. Since it is believed that the  $^{210}\text{Po}$  background mentioned above originates in the clamps holding the crystals, a special effort is devoted to producing clamps of highly pure material.

Also the installation of a further layer of polyethylene in the inner region around the detectors is being studied in order to provide additional shielding against neutrons originating in the inner parts of the setup.

Finally, efforts aimed at improvement of the light detection, which as discussed above, could play an important role in the identification of the recoil nucleus, continue to be a focus of detector development.

## References

- [1] "Detectability of Certain Dark Matter Candidates," M. W. Goodman and E. Witten, Phys. Rev. D **31**, 3059 (1985).

- [2] For a general introduction to the problems and ideas of detecting low energy interactions and using low temperatures see: L. Stodolsky, *Questions in the Detection of Very Low Energy Interactions*, in the Workshop on Theoretical and Phenomenological Aspects of Underground Physics, L'Aquila, Italy *TAUP 89*, A. Bottino and P. Monacelli eds. Editions Frontières, Gif-sur-Yvette (1989); and *Neutrino and Dark Matter Detection at Low Temperature* in *Physics Today*, August, 1991.
- [3] From “Commissioning Run of the CRESST-II Dark Matter Search,” G. Angloher, M. Bauer, I. Bavykina, A. Bento, A. Brown, C. Bucci, C. Ciemniak and C. Coppi *et al.*, *Astropartphys.* **31**, 270 (2009). arXiv:0809.1829 [astro-ph].
- [4] L. Stodolsky, “Features of Fast Neutrons in Dark Matter Searches,” *Astropart. Phys.* **35**, 114 (2011) [arXiv:1009.3791 [astro-ph.IM]].
- [5] See Fig 24 of “Light neutralinos as dark matter in the unconstrained minimal supersymmetric standard model,” A. Gabutti, M. Olechowski, S. Cooper, S. Pokorski and L. Stodolsky, *Astropart. Phys.* **6**, 1 (1996), [hep-ph/9602432].
- [6] “Detecting Cold Dark Matter Candidates,” A. K. Drukier, K. Freese and D. N. Spergel, *Phys. Rev. D* **33**, 3495 (1986).
- [7] “Results from 730 kg days of the CRESST-II Dark Matter Search,” G. Angloher, M. Bauer, I. Bavykina, A. Bento, C. Bucci, C. Ciemniak, G. Deuter and F. von Feilitzsch *et al.*, arXiv:1109.0702 [astro-ph.CO].
- [8] “p-values for model evaluation,” F. Beaujean, A. Caldwell, D. Kollar and K. Kroninger, *Phys. Rev. D* **83**, 012004 (2011).