

# Light Virtualization: a proof-of-concept for hardware-based virtualization

Francesco Ciruolo  
Boston University, USA  
fciraolo@bu.edu

Mattia Nicolella  
Boston University, USA  
mnico@bu.edu

Denis Hoornaert  
TU München, Germany  
denis.hoornaert@tum.de

Marco Caccamo  
TU München, Germany  
marco.caccamo@tum.de

Renato Mancuso  
Boston University, USA  
rmancuso@bu.edu

## ABSTRACT

Virtualization has become widespread across all computing environments, from edge devices to cloud systems. Its main advantages are resource management through abstraction and improved isolation of platform resources and processes. However, there are still some important tradeoffs as it requires significant support from the existing hardware infrastructure and negatively impacts performance. Additionally, the current approaches to resource virtualization are inflexible, using a model that doesn't allow for dynamic adjustments during operation. This research introduces Light Virtualization (LightV), a new virtualization method for commercial platforms. LightV uses programmable hardware to direct cache coherence traffic, enabling precise and seamless control over which resources are virtualized. The paper explains the core principles of LightV, explores its capabilities, and shares initial findings from a basic proof-of-concept module tested on commercial hardware.

### ACM Reference Format:

Francesco Ciruolo, Mattia Nicolella, Denis Hoornaert, Marco Caccamo, and Renato Mancuso. 2025. Light Virtualization: a proof-of-concept for hardware-based virtualization. In *Proceedings of ACM Conference (Conference'17)*. ACM, New York, NY, USA, 6 pages. <https://doi.org/10.1145/nnnnnnnn.nnnnnnnn>

## 1 INTRODUCTION

Virtualization is a staple of modern computing systems. In the last decade, support and use cases for hardware-aided virtualization have substantially proliferated, touching a wide range of real-world deployment from large-scale enterprise

Permission to make digital or hard copies of all or part of this work for personal or classroom use is granted without fee provided that copies are not made or distributed for profit or commercial advantage and that copies bear this notice and the full citation on the first page. Copyrights for components of this work owned by others than ACM must be honored. Abstracting with credit is permitted. To copy otherwise, or to publish, to post on servers or to redistribute to lists, requires prior specific permission and/or a fee. Request permissions from [permissions@acm.org](mailto:permissions@acm.org).

*Conference'17, July 2017, Washington, DC, USA*

© 2025 Association for Computing Machinery.

ACM ISBN 978-x-xxxx-xxxx-x/YY/MM...\$15.00

<https://doi.org/10.1145/nnnnnnnn.nnnnnnnn>

and cloud infrastructure [14], to general-purpose consumer computing [12], to embedded systems [3, 5]. Indeed, virtualization support offers flexible hardware provisioning, allows abstracting away resources, managing their visibility to guest OS's, and isolating them as needed to achieve multi-tenant/multi-domain setups with spatial and performance isolation properties.

Unfortunately, the virtualization superpower comes with a hefty price. First, the need to introduce one (or more) layers of software and hardware often comes with noticeable overheads [4]. Moreover, the additional software layers add complexity and widen the security attack surface [9]. Second, current support for virtualization is "binary", i.e., either everything or nothing in a system is virtualized. Although some hypervisors can be dynamically activated after boot [8], once a hypervisor is active, there is little to no control over what resources are virtualized and which ones are not. For instance, any memory page accessed by a guest OS must be mapped to physical memory by the hypervisor.

The aforementioned shortcomings of traditional memory and I/O virtualization technology arise from its reliance on page table-based address translation. However, what if one could *steer* address translation using arbitrary logic? In this case, intermediate-to-physical address resolution could be dynamically defined on the fly.

In this paper, we demonstrate that this is already possible in commercial hardware by surgically interacting with the cache coherence traffic originating from a CPU cluster. We refer to one such approach to enact resource virtualization as *Light Virtualization*, or LightV for short. LightV enables us to re-think virtualization support and opens the doors to untapped resource management paradigms. To this end, we present the proof-of-concept implementation of a hardware module capable of providing basic LightV primitives and the preliminary results we obtained on an initial single-page virtualization use case.

## 2 ANCILLARY CONCEPTS

This section covers fundamental concepts that are key to understanding LightV. The terminology used in this section

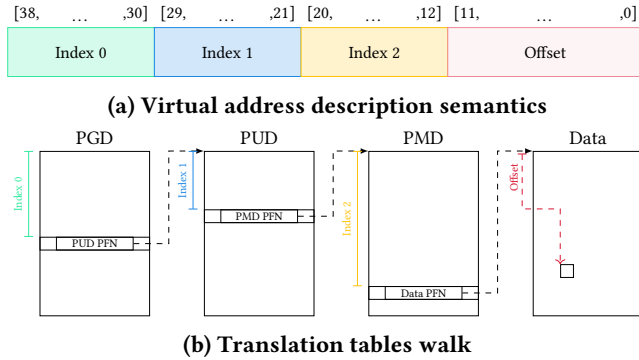

**Figure 1: VA to PA translation in AArch64, 4 KB page granularity and 4<sup>th</sup> level of translation folded.**

is based on AArch64 systems to ease the transition between the description of the concepts and our prototype.

**Address Translation.** Virtual memory is ubiquitous in modern general-purpose Operating System (OS). Its objective is to map a contiguous set of Virtual Addresses (VA) seen by a process to a set of Physical Addresses (PA) that may not be contiguous at a given granule (page) size.

To allow for the implementation of arbitrary mappings, virtualization is achieved via page tables, i.e., a  $l$ -level  $n$ -ary radix tree walked by segmenting the VA in several indices. Fig. 1 illustrates how a page table walk is performed on AArch64 systems. A page table is looked up using said indices, shown in green, blue, or orange in Fig. 1. At each translation step, the content of the Page Table Entry (PTE) is a *pointer* to the following translation step or a leaf page. Specifically, the PTE contains the Page Frame Number (PFN) of the next page table or of the final mapped data page. Page table walks are handled in hardware by the Memory Management Unit (MMU) upon each CPU-originated VA memory access. As translations may occur frequently and are time costly, MMUs are often equipped with multiple levels of Translation Look-aside Buffer (TLB) to cache translation results. Usually, the MMUs can access the same cache hierarchy as the CPU load/store unit.

**Type 1 Hypervisors.** The terminology “*Type 1 Hypervisors*” refers to a class of bare-metal hypervisors that directly interfaces a hosted Virtual Machine (VM) with the hardware layer. They can partition system resources (memory, I/O devices) to the VMs by leveraging specialized hardware support that introduces yet another level of indirection between VAs as translated by VMs and real PAs. Similarly to the VA-to-PA translation described above, a secondary translation stage is introduced, leveraging page tables again. In this case, OSes in VMs are said to translate VAs to Intermediate Physical Addresses (IPAs) whereas, hypervisor-side page tables translate IPAs to PAs. Of course, this extra translation layer introduces additional overheads, as up to two full page

table walks may be performed for a single VA memory access. Moreover, hypervisor bookkeeping operations and the handling of VM exits steal CPU time from the hosted VMs.

**Cache Coherence.** In modern multi-processors SoCs where the cache hierarchy is a key performance enabler, ensuring a consistent view of the memory to all attached PEs is crucial. Snoop-based coherence is a common coherence paradigm. The core idea is to attach a few bits to each cache line to encode its state (e.g., *Modified, Shared, Invalid*) in the cache hierarchy. The state of each cache line in the hierarchy is continuously updated as they are accessed by the PEs.

Under snoop-based coherence, PE-originated read/write requests prompt a coherence controller (e.g., interconnect) to broadcast commands to all other attached PEs. These commands directly affect the state of the targeted cache lines in the PEs’ caches. For instance, a read-miss event from PE1 will prompt the controller to broadcast a snoop request. If the snoop results in a hit in PE2’s cache, the line state in PE2’s cache will be altered—e.g., (i) from clean and exclusive to clean and shared or (ii) from modified and exclusive to invalid [7]. Conversely, in case of a miss in the cache of all the other coherent PEs, the request is forwarded to the next level of the cache hierarchy (e.g., another cache level or main memory), and the line is allocated in PE1’s cache.

On AArch64 SoCs, the AXI Coherency Extension (ACE) is an established bus-level interface to implement snoop-based coherence protocols. For instance, ACE-enabled CPU-side cache controllers and interconnects (e.g., ARM CCI-400 [13]) are the basic components of a coherent multi-cluster big.LITTLE architecture [2, 6].

**Coherence Backstabbing.** Simply put, the idea behind *Coherence Backstabbing* as originally proposed in [10] is to hijack the coherence protocol for purposes other than maintaining coherence among a multi-PE system where one of the PEs is a coherent FPGA [1]. Coherence backstabbing leverages the idea that a coherent PE can *pretend* to have ownership of a cache line, fabricate its content, and feed it to the other PE. In other words, by “*placing itself on the back of the coherence protocol*” [10], a custom user-defined hardware module can seamlessly intercept, modify, and reroute any coherent traffic—e.g., cache line refills.

### 3 SWITCHING TO A LIGHTER WEAPON

As an alternative approach to traditional virtualization, we propose Light Virtualization (LightV). LightV is a paradigm to implement hardware modules that build atop the concept of coherence backstabbing [10] to arbitrarily manipulate VA-to-PA translation in a manner that remains seamless to software components. LightV can achieve *transparent, temporary, and on-demand* control over the translation process. This is achieved through observation and selective

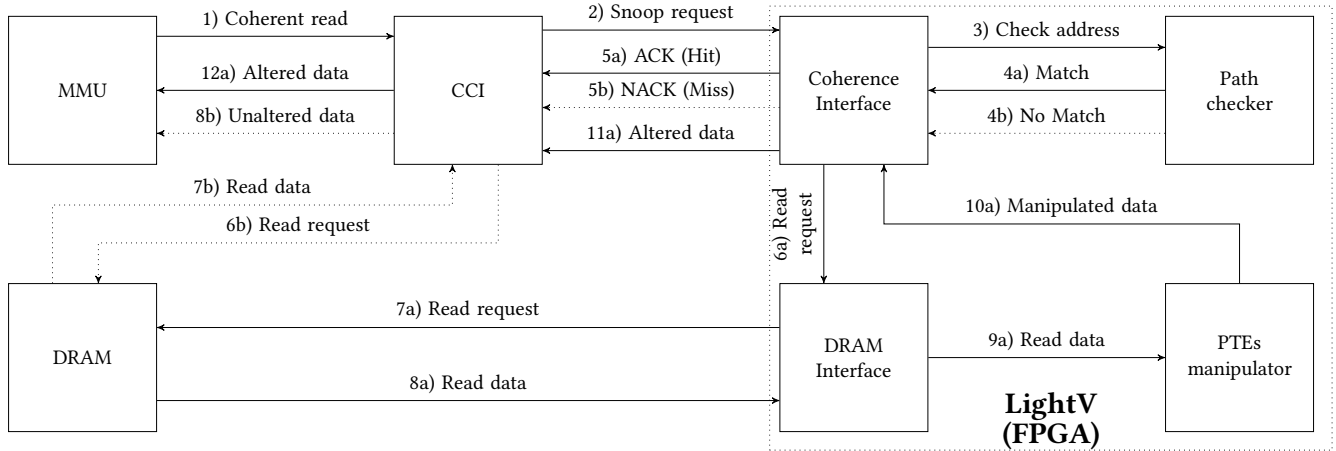

Figure 2: Skeleton and fundamental operations of a basic LightV module

manipulation of the data payloads returned via coherence in response to MMU-generated snoops during the page table walk. This level of control allows for a “true” in-hardware virtualization with little support required from the vendors.<sup>1</sup>

### 3.1 System Model

A few features are required for LightV to be deployed on a SoC. The system must include one or more PEs (*e.g.*, CPU, CPUs cluster, GPU) supporting memory virtualization (*i.e.*, equipped with an MMU and TLBs). The PE-side cache must be capable of handling coherence and be connected to a coherent controller (*e.g.*, coherent interconnect) employing a snoop-based protocol. The latter interfaces the coherence domain with main memory. MMU-originated accesses to PTEs during page table walks are treated as cacheable, and therefore generate snoops that are broadcasted to all other coherent PEs upon a PE-side cache miss.

We make no assumptions on whether the module is implemented as soft-logic in a programmable logic fabric (as in [10]) or as a fixed dedicated piece of hardware. To illustrate the basic principle, however, we hereby make the following simplifying assumptions. We discuss in Sec. 3.3 how these can be substantially relaxed.

- (1) No PTEs are cached. All MMU-originated accesses miss in the PE-side cache and the corresponding snoops are broadcasted to the other coherent PEs.
- (2) The target VA range is *isolated* and *pre-mapped*. *I.e.*, no other valid VAs share the same first index, and all the intermediate PTEs have been pre-populated before LightV is activated.
- (3) The PGD of the target address space that contains the target VAs is known before LightV is activated.

- (4) The new destination PAs and desired mapping attributes are provided by the end-user.

### 3.2 LightV Operation

As shown in Fig. 2, the LightV module activates each time it receives a snoop command. This command is analyzed and compared (step (3)) to determine if the snoop command results from a PTE access that was missed in the cache. At the very beginning, *i.e.*, right after the LightV module has been activated, the check is performed against the known PGD address plus possible offsets. Later, the check will also include any intermediate PFNs of valid page tables obtained in the previous translation steps for the VAs of interest.

If the snooped address indicates access to a PTE of interest, the LightV module acknowledges the request (step (5a)), indicating to the cache coherent interconnect (CCI) that it has the most up-to-date data payload. From then on, the latter waits for the data to be served at step (11a). Meanwhile, the LightV module fetches from main memory the payload of the requested PTE (steps (7a) and (7b)). The payload is passed (step (9a)) to the PTEs manipulator. Here, it can be altered as necessary following arbitrary logic before being fed to the coherent controller (step (11a)) and eventually the MMU (step (12a)). Note that, in parallel to this process, the LightV module internally maintains a *context cache* within the translation path checker. This is useful for storing additional metadata about the current translation.

Conversely, if the snoop is not relevant for the translation of any of the VAs of interest (step (4b)), the LightV module provides a negative acknowledgment to the CCI (step (5b)). From there, a “text-book” access to the page tables is performed by fetching the non-altered tables directly from main memory (steps (6b) and (7b)).

<sup>1</sup>Although, the model can be further simplified and improved if additional support is provided in hardware, as discussed in Sec. 5.2.

Note that, with no PTEs cached on the PE side, the routine will be repeated once per active page table level to complete a full-page table walk—*e.g.*, up to four times in AArch64.

### 3.3 Relaxing LightV Assumptions

The assumptions listed in Sec. 3.1 are representative of the various technical challenges that remain to be addressed. This section explains the rationale behind each assumption and how they can be enforced or relaxed.

**Assumption (1).** Disabling the caching of PTEs in the cache hierarchy is undesirable, as it is crucial to hide costly translation latencies. On the other hand, if intermediate PTEs passed to the PE might be cached, then not all the MMU-generated PTE accesses will result in PE-side cache misses and snoops. This *partial observability* means that LightV is oblivious to the walks' progress and, thus, cannot determine how to appropriately alter the translations when the next relevant PTE miss occurs.

Fortunately, the PTE addresses returned by the LightV module do not have to be valid PAs—because accesses to them will be intercepted when later snooped. Thus, we can inject a *watermark* in the payload of all the manipulated PTEs served to the PE. In addition to encoding the translation step number, the watermark can be looked up in the internal context cache (Sec. 3.2) to recover several other attributes necessary for proper LightV operation.

**Assumption (2).** The reason for **Assumption (2)** is to avoid that also neighbor VAs sharing intermediate page tables could trigger the same issue raised if Assumption (3) was lifted. Thus, it can be relaxed if Assumption (3) is lifted.

**Assumption (3).** Assuming pre-populated VA mappings before LightV is activated is a simplifying assumption because Linux employs demand paging. In brief, if the LightV module serves a manipulated PTE but no subsequent page is allocated (present bit is cleared), the MMU generates a fault. When handling the fault, the kernel retrieves the potentially invalid PA of the PTE and might attempt to populate it. However, as the address is invalid and only makes sense when looked up in the context cache, it might cause a kernel-side page fault. This problem can be solved with an LightV module capable of consistently manipulating both user-space and kernel-space VA-to-PA translations.

### 3.4 Enabling Virtualization at All Levels

The proposed approach does not preclude the system from running a hypervisor. In fact, the mechanism presented earlier can be extended to hypervisor translations, too. Instead of intervening only during the VA-to-PA translation, LightV could also monitor and alter IPA-to-PA translations.

## 4 ON THE BATTLEFIELD

We have implemented a first prototype of LightV as outlined in Sec. 3 on the Zynq UltraScale+ MPSoC ZCU102 development board. This board features a SoC composed of four ARM64 Cortex-A53 CPU cores and a coherent FPGA which hosts our LightV prototype. This initial prototype implements the watermarking feature discussed in Sec. 3.3 to address Assumption (1). However, the prototype still requires an isolated target VA, as per Assumption (2) and that the VA mappings are pre-populated—Assumption (3). This prototype focuses on virtualizing a subset of pages in a Linux user-space process. This section presents early results w.r.t. measured overhead introduced by LightV.

### 4.1 Overhead

Linux	Passive SNV	Active SNV	Jailhouse
$2.39 \pm 0.035s$	$2.4 \pm 0.052s$	$2.38 \pm 0.04s$	$2.38 \pm 0.034s$

**Table 1: Avg/min/max runtime of the histogram benchmark. "Active LightV" has single-page virtualization.**

To measure the overheads of single-page virtualization, the RGB histogram benchmark was chosen, with an  $\sim 55.6$  MB input image. This application is characterized by a large pool of cold pages for the image data, warmer pages for the code itself, and a single hot page for the aggregated data of the histogram; the VA of the latter is the target for LightV.

The benchmark is executed under three scenarios, shown in Table 1: **Linux**: Linux without LightV being implemented in the FPGA, averaging  $2.39 \pm 0.035s$ ; **Passive LightV**: our LightV module is instantiated in the FPGA as a coherent master but it has no target VAs, averaging  $2.38 \pm 0.04s$ ; **Active LightV**: LightV implemented and enabled to virtualize a single page, averaging  $2.38 \pm 0.04s$ . Comparing the **Linux** and **Passive LightV** cases captures the overhead introduced by adding a master to the coherence domain. As reported in Table 1, the overhead is negligible. Indeed, **Active LightV** introduces overheads that are in line with the 1% figure reported by previous works [5] for common type-1 hypervisors—*e.g.*, Jailhouse, which we also evaluate in Table 1.

### 4.2 Ascertained Novel Features

**Selective Virtualization.** Our technology allows virtualizing just what is needed with the granularity of a single process/OS page. Unlike traditional virtualization, any translation outside the range of interest will be minimally impacted since no additional steps are added in this case—step (5b) in Fig. 2. Moreover, since the LightV machinery is synthesized in FPGA, no virtualization management cost, in the form of



extra instructions to be executed on the CPU, needs to be paid. Finally, no additional main memory will be allocated for 1:1 flat translations.

**Dynamic Translation Semantics.** As noted previously, the content of traditional translation tables can be changed at any time, allowing more sophisticated mapping. Usually, however, this is an expensive operation, and use cases beyond allocation/deallocation of new areas are seldom performed. Conversely, under LightV, the rule-based, dynamic translation is more lightweight, and arbitrarily complex semantics can be implemented in the FPGA.

## 5 NEXT STEPS

While the proof-of-concept prototype presented in this paper is a promising stepping stone toward full-fledged LightV, much more research is needed to fully explore the many new avenues opened by this technique.

On the one hand, our immediate future work is focused on tackling the key challenges discussed in Sec. 3.3. To this end, we aim to design a LightV module capable of providing virtualization for an arbitrarily large portion of the virtual addressing space of a user-space application running in a typical OS, e.g., Linux. On the other hand, we envision that several potential paradigms are within reach after that, as summarized below.

### 5.1 Future Paradigms Enabled by LightV

**Seamless pages migration.** Migrating one or more pages of a user process or guest OS is not uncommon and done for multiple reasons—e.g., moving a page closer to the physical core in a NUMA configuration, exploiting faster/non-volatile memory. Nonetheless, page migration is an expensive operation, requiring the processes involved to be blocked while busy-copy or DMA operations are performed and the affected page table(s) are updated.

With LightV, it is possible to seamlessly migrate pages. Upon migration, (i) a DMA operation is issued to copy a given page; simultaneously, (ii) any TLB entry for the page is invalidated by the LightV module, which (iii) manipulates future translations to target the new page location. Before the DMA operation completes, (iv) any access performed by the **running** processes is captured at the coherence level and replied with the data of the source page. (v) Once the DMA completes, the old page can be reclaimed, and accesses to the new page are not captured anymore.

**Multiple Hypervisors Coexistence.** State-of-the-art virtualization support allows for, at most, a single type-1 hypervisor active in the system. By leveraging LightV, it is also possible to manipulate hypervisor-side translations. Thus, it

is foreseeable that multiple type-1 hypervisors could be allowed to operate simultaneously on the same physical platform.

**I/O Device Sharing.** Type-1 hypervisors can statically assign a given I/O resource in pass-through mode to a single VM. Exporting the same device to multiple VMs requires device emulation or advanced support like SR-IOV [11].

We envision that LightV could enable I/O device virtualization in two ways. (i) First, one could replace the physical PFN of the I/O device's control registers and buffers with dedicated addresses in the FPGA aperture while having a hardware module in charge of selectively forwarding commands and data to the true aperture of the memory-mapped I/O device. (ii) Second, one could change the attribute set of the mapped physical device aperture to mark any page within that as cacheable. This way, accessing them will cause snoops that can be intercepted and manipulated. In this case, cache maintenance operations are also issues on the coherence interface to prevent stale data from being retained in any CPU-side caches.

The main advantage of scenario (i) is that it provides deterministic and direct knowledge of a VMs' access to the device's registers. Indeed, the intercepted read/write bus transaction contains the exact target register address and the same width. Conversely, in scenario (ii), a cache line snoop can only target a cache line size-aligned address. Also, recovering the type of access (read vs. write) could prove challenging. On the other hand, approach (ii) allows a more compact design and seamless interaction without dedicating a portion of the FPGA address range to the virtualized device.

**Code Execution and Interrupt Virtualization.** For LightV to ultimately offer full-fledged virtualization support, the ability to execute management code on the CPU is also desirable, as typical in type-1 hypervisors. It might appear that LightV only allows some address translation *tricks*. Nonetheless, the translation tricks can be leveraged to unlock code execution in LightV. This is because, by carefully steering the physical translation of instruction fetches, LightV can direct the execution flow of the CPU to any code in memory.

But that's not all. A LightV module could simply replace, at the coherence level, the payload of the next cache line of instructions that is about to be executed by the CPU, by hijacking the corresponding snoop request. The instructions served instead might be fetched from memory or procedurally generated on the fly as needed. Remarkably, by applying this approach when interrupt handling routines are executed, interrupt virtualization in LightV can be achieved as well.

## 5.2 On the vendors

While our solution is thought to be seamless and transparent to be integrates within existing off-the-shelf systems, there is some hardware support that could be easily implemented by the vendors and could make the development easier and the tool more powerful. Some of the most relevant challenges depend on *guessing* the intention of the main CPU cluster – core or MMU – with a given snoop request; in fact, the latter misses information about the exact address requested and even the nature – read or write – of the access.

Especially in the optic of the close approach of the Compute Express Link standard, it could be valuable to have some additions to the coherence protocol: the snoop requests should have information related to the (i) memory access direction, (ii) the offset – in the cache line – of the requested data and (iii) the source of the request – *i.e.*, the core or MMU ID – in a standard way; also, as an optional feature, (iv) even in the case of a cache hit, at any level, a snoop should be performed and potentially waited for, so that the coherent hardware hypervisor can apply a veto and replace the content of the cache line.

## REFERENCES

- [1] G. Alonso, T. Roscoe, D. Cock, M. Ewaida, Kaan Kara, Dario Korolija, D. Sidler, and Ze ke Wang. Tackling hardware/software co-design from a database perspective. In *Conference on Innovative Data Systems Research (CIDR)*, Amsterdam, Netherlands, Jan. 2020.
- [2] Hongsuk Chung, Munsik Kang, and Hyun-Duk Cho. Heterogeneous multi-processing solution of exynos 5 octa with arm big. little technology. *Samsung White Paper*, 2012.
- [3] Gernot Heiser. The role of virtualization in embedded systems. In *Proceedings of the 1st Workshop on Isolation and Integration in Embedded Systems, IIES '08*, page 11–16, New York, NY, USA, 2008. Association for Computing Machinery.
- [4] Zheng Li, Maria Kihl, Qinghua Lu, and Jens A. Andersson. Performance overhead comparison between hypervisor and container based virtualization. In *2017 IEEE 31st International Conference on Advanced Information Networking and Applications (AINA)*, pages 955–962, 2017.
- [5] José Martins and Sandro Pinto. Shedding light on static partitioning hypervisors for arm-based mixed-criticality systems. In *2023 IEEE 29th Real-Time and Embedded Technology and Applications Symposium (RTAS)*, pages 40–53, 2023.
- [6] Arm Limited or its affiliates. Processing Architecture for Power Efficiency and Performance. Technical report, 2022.
- [7] Mark S. Papamarcos and Janak H. Patel. A low-overhead coherence solution for multiprocessors with private cache memories. *SIGARCH Comput. Archit. News*, 12(3):348–354, January 1984.
- [8] Ralf Ramsauer, Jan Kiszka, Daniel Lohmann, and Wolfgang Mauerer. Look mum, no vm exits! (almost). In *Proceedings of the 13th Workshop on Operating Systems Platforms for Embedded Real-Time Applications (OSPERT)*, 2017.
- [9] Andrew R. Riddle and Soon M. Chung. A survey on the security of hypervisors in cloud computing. In *2015 IEEE 35th International Conference on Distributed Computing Systems Workshops*, pages 100–104, 2015.
- [10] Shahin Roozkhosh, Denis Hoornaert, and Renato Mancuso. CAESAR: Coherence-Aided Elective and Seamless Alternative Routing via on-chip FPGA. In *Proceedings of the Real-Time Systems Symposium (RTSS)*, 2022.
- [11] Jun Suzuki, Yoichi Hidaka, Junichi Higuchi, Teruyuki Baba, Nobuharu Kami, and Takashi Yoshikawa. Multi-root share of single-root i/o virtualization (sr-iov) compliant pci express device. In *2010 18th IEEE Symposium on High Performance Interconnects*, pages 25–31, 2010.
- [12] C. Wolf and E.M. Halter. *Virtualization: From the Desktop to the Enterprise*. Books for Professionals by Professionals. Apress, 2006.
- [13] Xilinx. ARM® CoreLink™ CCI-400 Cache Coherent Interconnect. Technical report, 2015.
- [14] Yuping Xing and Yongzhao Zhan. Virtualization and cloud computing. In Ying Zhang, editor, *Future Wireless Networks and Information Systems*, pages 305–312, Berlin, Heidelberg, 2012. Springer Berlin Heidelberg.