

Multi-Granularity Tibetan Textual Adversarial Attack Method Based on Masked Language Model

Xi Cao

School of Information Science and Technology, Tibet University;
Collaborative Innovation Center for Tibet Informatization by MOE and Tibet Autonomous Region
Lhasa, Xizang, China
metaphor@outlook.com

Nuo Qun*

School of Information Science and Technology, Tibet University;
Collaborative Innovation Center for Tibet Informatization by MOE and Tibet Autonomous Region;
Engineering Research Center of Tibetan Information Technology,
Ministry of Education
Lhasa, Xizang, China
q_nuo@utibet.edu.cn

Quzong Gesang

School of Information Science and Technology, Tibet University;
Collaborative Innovation Center for Tibet Informatization by MOE and Tibet Autonomous Region
Lhasa, Xizang, China
gsqz1212@qq.com

Yulei Zhu

School of Information Science and Technology, Tibet University;
Engineering Research Center of Tibetan Information Technology,
Ministry of Education
Lhasa, Xizang, China
zhuyulei@utibet.edu.cn

Trashi Nyima

School of Information Science and Technology, Tibet University;
Collaborative Innovation Center for Tibet Informatization by MOE and Tibet Autonomous Region;
Engineering Research Center of Tibetan Information Technology,
Ministry of Education
Lhasa, Xizang, China
nmzx@utibet.edu.cn

ABSTRACT

In social media, neural network models have been applied to hate speech detection, sentiment analysis, etc., but neural network models are susceptible to adversarial attacks. For instance, in a text classification task, the attacker elaborately introduces perturbations to the original texts that hardly alter the original semantics in order to trick the model into making different predictions. By studying textual adversarial attack methods, the robustness of language models can be evaluated and then improved. Currently, most of the research in this field focuses on English, and there is also a certain amount of research on Chinese. However, there is little research targeting Chinese minority languages. With the rapid development of artificial intelligence technology and the emergence of Chinese minority language models, textual adversarial attacks become a new challenge for the information processing of Chinese minority languages. In response to this situation, we propose a

multi-granularity Tibetan textual adversarial attack method based on masked language models called *TSTricker*. We utilize the masked language models to generate candidate substitution syllables or words, adopt the scoring mechanism to determine the substitution order, and then conduct the attack method on several fine-tuned victim models. The experimental results show that *TSTricker* reduces the accuracy of the classification models by more than 28.70% and makes the classification models change the predictions of more than 90.60% of the samples, which has an evidently higher attack effect than the baseline method.

CCS CONCEPTS

- **Computing methodologies** → **Natural language processing;**
- **Security and privacy** → **Systems security.**

KEYWORDS

Textual Adversarial Attack, Language Model, Robustness, Tibetan

ACM Reference Format:

Xi Cao, Nuo Qun, Quzong Gesang, Yulei Zhu, and Trashi Nyima. 2024. Multi-Granularity Tibetan Textual Adversarial Attack Method Based on Masked Language Model. In *Companion Proceedings of the ACM Web Conference 2024 (WWW '24 Companion)*, May 13–17, 2024, Singapore, Singapore. ACM, New York, NY, USA, 9 pages. <https://doi.org/10.1145/3589335.3652503>

*Corresponding author.

Permission to make digital or hard copies of all or part of this work for personal or classroom use is granted without fee provided that copies are not made or distributed for profit or commercial advantage and that copies bear this notice and the full citation on the first page. Copyrights for components of this work owned by others than the author(s) must be honored. Abstracting with credit is permitted. To copy otherwise, or republish, to post on servers or to redistribute to lists, requires prior specific permission and/or a fee. Request permissions from permissions@acm.org.
WWW '24 Companion, May 13–17, 2024, Singapore, Singapore.

© 2024 Copyright held by the owner/author(s). Publication rights licensed to ACM.
ACM ISBN 979-8-4007-0172-6/24/05...\$15.00
<https://doi.org/10.1145/3589335.3652503>

1 INTRODUCTION

Textual adversarial attack refers to an attack method in which the attacker adds perturbations to the original text that almost do not affect the original semantics, resulting in the incorrect prediction of the language model. The samples generated by the textual adversarial attack are called adversarial texts. Studying textual adversarial attack methods can evaluate the robustness of the language model and expose its security vulnerabilities. Using adversarial texts to train the language model can achieve the effect of improving the model's robustness and actively defending against attacks.

Szegedy et al. [17] first found that adding imperceptible noise to the original picture can make the neural network's prediction wrong. Initially, research on adversarial attacks was limited to the image domain [5, 17]. Later, Jia and Liang [7] found that language models are also vulnerable to adversarial attacks. For the reading comprehension system, adding interfering statements to the original paragraph can make the model understand incorrectly. So far, research on textual adversarial attacks mostly focuses on English [3, 4, 8, 12, 14, 21]. Wang et al. [19] first utilized homophonic word substitution to generate Chinese adversarial texts, and since then some research on textual adversarial attack methods for Chinese has appeared [6, 11, 23]. Most of the Chinese textual adversarial attacks have considered the characteristics of the Chinese language itself. For example, a simplified Chinese character can be converted into a traditional Chinese character, rewritten into Chinese Pinyin, or split into Chinese character components. Moreover, native Chinese speakers have a certain degree of tolerance towards Chinese characters that are similar in pronunciation or shape. However, there is currently little relevant research on Chinese minority languages.

With the development of artificial intelligence technology and the construction of informatization in Tibetan areas of China, PLMs (pre-trained language models) targeting or including Tibetan have appeared in the past two years, such as monolingual models TibetanBERT [22] and TiBERT [13], and multilingual models CINO [20], MiLMo [2] and CMPT [9], etc. Tibetan language models obtained through the paradigm of "PLMs + Fine-tuning" can achieve good results in downstream tasks. Recently, Cao et al. [1] proposed the first textual adversarial attack method targeting Tibetan and called attention to the robustness and security of Chinese minority language models. They used cosine similarity to generate candidate substitution syllables and implemented their attack method on one kind of language model. Textual adversarial attack is a new challenge for the information processing of Chinese minority languages. The study of textual adversarial attack methods targeting the Tibetan language is of practical significance for the informatization construction and stable development of Tibetan areas in China.

The main contributions of this paper are as follows:

(1) This paper proposes a multi-granularity Tibetan textual adversarial attack method based on masked language models called *TStricker* which can attack from syllable and word granularity. The attack effect is significantly stronger than the baseline method.

(2) This paper implements the attack method on the BERT-based monolingual model targeting Tibetan and the XLMRoBERTa-based multilingual model including Tibetan. The experimental results show the vulnerability of these language models in terms of robustness.

(3) This paper finds that using publicly available PLMs can effectively carry out textual adversarial attacks on language models in downstream tasks, providing theoretical guidance for active defense in the future.

(4) This paper calls more attention to the security issues in the information processing of Chinese minority languages. In order to facilitate further research, we make the models involved in this paper publicly available on Hugging Face (<https://huggingface.co/UTibetNLP>) and the code involved in this paper publicly available on GitHub (<https://github.com/UTibetNLP/TStricker>).

2 PRELIMINARIES

2.1 Textual Adversarial Attacks on Text Classification

For a text classification task, let x be the original input text ($x \in X$, X includes all possible input texts), F be the classifier, and the output label of F on x be y ($y \in Y$, Y includes all possible output labels), denoted as

$$F(x) = \arg \max_{y^* \in Y} P(y^* | x) = y. \quad (1)$$

Let δ be the perturbation on x and x' be the input text after the perturbation, then $x' = x + \delta$. By elaborately designing δ , the attacker makes the semantics of the input text basically unchanged. The attacker achieves a successful textual adversarial attack when

$$F(x') = \arg \max_{y^* \in Y} P(y^* | x') \neq y. \quad (2)$$

2.2 Characteristics of Tibetan Script

Tibetan is a phonetic script composed of 30 consonant letters and 4 vowel letters, each of which has its corresponding Unicode. These letters are spelled into Tibetan syllables by strict rules, and one or more Tibetan syllables form Tibetan words, separated by Tibetan separators called Tsheg. Therefore, the granularity of Tibetan script, from small to large, is divided into letters [or Unicodes], syllables, and words, which is different from English (letters [or Unicodes], words) and Chinese (characters [or Unicodes], words). Figure 1 illustrates the structure of a Tibetan word clearly. Let the syllable in the original input text x be s (ignore Tsheg) and the word be w , then

$$x = s_1 s_2 \dots s_i \dots s_m, \quad (3)$$

$$x = w_1 w_2 \dots w_j \dots w_n. \quad (4)$$

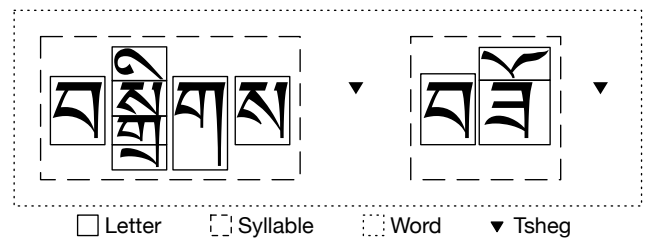

Figure 1: Structure of Tibetan Word Programming

3 ATTACK METHOD

In this section, we will detail the *TStricker* algorithm, a multi-granularity Tibetan textual adversarial attack method based on masked language models. We utilize the masked language models to generate candidate substitution syllables or words and adopt the scoring mechanism to determine substitution order.

3.1 Generate Substitutions

Tibetan-BERT¹ [22] and TiBERT² [13] are both BERT-based Tibetan monolingual PLMs, but their tokenizers are different. The tokenizer granularity of Tibetan-BERT is syllable and sub-syllable, while the tokenizer granularity of TiBERT is word, sub-word, and syllable (including Tsheg). Tibetan-BERT and TiBERT as masked language models can well predict the missing syllables and words of the text, respectively, and make the semantics unobstructed. In this work, we use Tsheg and the word segmentation tool TibetSegEYE³ to segment the original input text into syllables and words.

For each syllable s and word w in the original input text x , we use Tibetan-BERT and TiBERT to predict the possible top- k syllables and words other than the original syllable and word as the set of candidate substitution syllables C_s and the set of candidate substitution words C_w , respectively. In our experiment, k is set to 50 by default, and syllables are filtered out for the prediction results of Tibetan-BERT and words are filtered out for the prediction results of TiBERT. After that, we iterate over the syllable s' in C_s or the word w' in C_w , then

$$x' = s_1 s_2 \dots s_i' \dots s_m \text{ or } x' = w_1 w_2 \dots w_j' \dots w_n, \quad (5)$$

and calculate

$$\Delta P = P(y|x) - P(y|x'). \quad (6)$$

After the iteration is completed, the syllable s^* or the word w^* can be always found, and

$$x^* = s_1 s_2 \dots s_i^* \dots s_m \text{ or } x^* = w_1 w_2 \dots w_j^* \dots w_n, \quad (7)$$

at which point,

$$\begin{aligned} \Delta P^* &= P(y|x) - P(y|x^*) \\ &= \max\{\Delta P_k\}_{k=1}^{\text{size}(C_s \text{ or } C_w)} \\ &= \max\{P(y|x) - P(y|x'_k)\}_{k=1}^{\text{size}(C_s \text{ or } C_w)}, \end{aligned} \quad (8)$$

$$\begin{aligned} s^* \text{ or } w^* &= \arg \max_{\substack{s' \in C_s \\ w' \in C_w}} \{\Delta P_k\}_{k=1}^{\text{size}(C_s \text{ or } C_w)} \\ &= \arg \max_{\substack{s' \in C_s \\ w' \in C_w}} \{P(y|x) - P(y|x'_k)\}_{k=1}^{\text{size}(C_s \text{ or } C_w)}. \end{aligned} \quad (9)$$

It means that substituting the syllable s with s^* or the word w with w^* can result in the largest decrease in classification probability and the best attack effect. Figure 2 illustrates this process.

3.2 Determine Substitution Order

Li et al. [10] proposed *word saliency*, which refers to the drop value of the classification probability after setting a word in the original input text to unknown. We use this metric to calculate the saliency of a syllable or word. Let

$$\hat{x} = s_1 s_2 \dots \text{unk} \dots s_m \text{ or } \hat{x} = w_1 w_2 \dots \text{unk} \dots w_n, \quad (10)$$

$$S = P(y|x) - P(y|\hat{x}). \quad (11)$$

Ren et al. [16] further proposed *probability weighted word saliency* and the metric is as follows:

$$H = \text{Softmax}(S) \cdot \Delta P^*, \quad (12)$$

which takes into account the saliency of both the substituted word and the substitution word. We use this metric to decide the order of substituting syllables or words. After sorting all the scores $\{H_1, H_2, \dots\}$ corresponding to the original input text x in descending order, we sequentially substitute the syllable s_i with s_i^* or substitute the word w_j with w_j^* until the output label changes, then the attack succeeds. Otherwise, the attack fails. Figure 3 illustrates this process.

3.3 Pseudocode

The pseudocode of the syllable-level *TStricker* algorithm is as shown in Algorithm 1.

4 EXPERIMENT

4.1 Victim Language Models

We use the paradigm of “*PLMs + Fine-tuning*” to construct victim language models. We divide each dataset in the downstream tasks into a training set, a validation set, and a test set according to the ratio of 8:1:1. On the training set, we fine-tune the PLMs to generate the victim language models, and on the test set, we conduct the attack method on the victim language models. We select the Tibetan news title classification dataset TNCC-title [15] and the Tibetan sentiment analysis dataset TU_SA [24]. We select Tibetan-BERT [22], a monolingual PLM targeting Tibetan, and CINO series [20], a series of multilingual PLM including Tibetan. At last, 8 victim language models are constructed which we make them publicly available on Hugging Face (<https://huggingface.co/UTibetNLP>) for future research. Table 1 lists the detailed information of the datasets. Table 2 lists the hyperparameters of the fine-tuning. Table 3 and Table 4 respectively list the performance of the models on TNCC-title and TU_SA. Figure 4 also presents the performance of these victim language models in the form of radar charts. The following is a brief introduction to the datasets and the PLMs.

4.1.1 Datasets.

- **TNCC-title⁴**. A Tibetan news title classification dataset. Qun et al. [15] collect the dataset from the China Tibet Online website (<http://tb.tibet.cn>). This dataset contains a total of 9,276 Tibetan news titles, which are divided into 12 classes: politics, economics, education, tourism, environment, language, literature, religion, arts, medicine, customs, and instruments.

¹https://huggingface.co/UTibetNLP/tibetan_bert

²<http://tibet.cmlil-nlp.com/>

³<https://github.com/yjspho/TibetSegEYE>

⁴<https://github.com/FudanNLP/Tibetan-Classification>

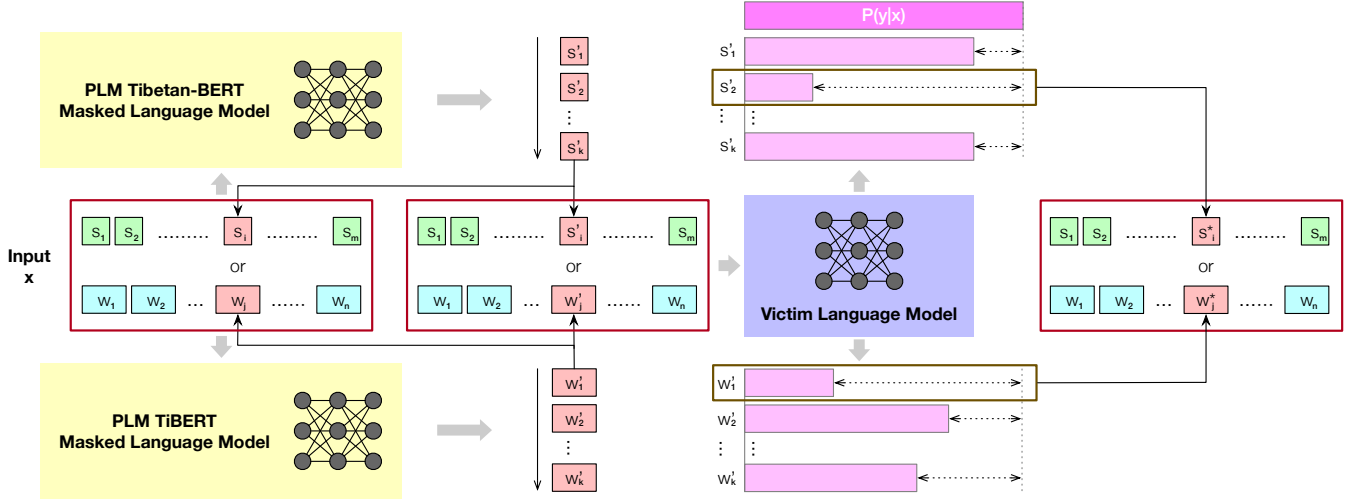

Figure 2: Process of Generating Substitutions

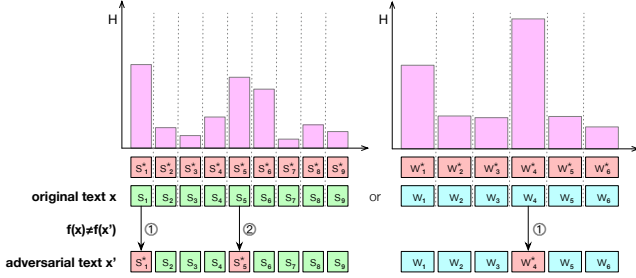

Figure 3: Process of Determining Substitution Order

- **TU_SA**⁵. A Tibetan sentiment analysis dataset. Zhu et al. [24] build the dataset by translating and proofreading 10,000 sentences from two public simplified Chinese sentiment analysis datasets weibo_senti_100k and ChnSentiCorp (<https://github.com/SophonPlus/ChineseNlpCorpus>). In this dataset, negative and positive classes each account for 50%.

4.1.2 PLMs.

- **Tibetan-BERT**⁶. A BERT-based monolingual PLM targeting Tibetan. Zhang et al. [22] propose and release the first Tibetan BERT PLM, which achieves a good result on the specific downstream Tibetan text classification dataset.
- **CINO**^{7,8,9}. A XLMRoBERTa-based multilingual PLM including Tibetan. Yang et al. [20] propose and release the first multilingual PLM for Chinese minority languages, covering Standard Chinese, Yue Chinese and six ethnic minority languages. It achieves SOTA performance on multiple monolingual or multilingual text classification datasets.

⁵https://github.com/UTibetNLP/TU_SA
⁶https://huggingface.co/UTibetNLP/tibetan_bert
⁷<https://huggingface.co/hfl/cino-small-v2>
⁸<https://huggingface.co/hfl/cino-base-v2>
⁹<https://huggingface.co/hfl/cino-large-v2>

Algorithm 1: Syllable-Level TStricker Algorithm

```

Input: Classifier  $F$ .
Input: Original text  $x = s_1 s_2 \dots s_i \dots s_m$ .
Output: Adversarial text  $x'$ .
1 for  $i \leftarrow 1$  to  $m$  do
2   // Prepare to calculate  $\text{Softmax}(S_i)$  in line 15.
3    $\hat{x}_i \leftarrow s_1 s_2 \dots \text{unk} \dots s_m$  // Equation 10
4    $S_i \leftarrow P(y|x) - P(y|\hat{x}_i)$  // Equation 11
5 end
6 Init  $L$  as an empty list.
7 for  $i \leftarrow 1$  to  $m$  do
8   Get  $C_{s_i}$ , the set of candidate substitution syllables,
   according to Tibetan-BERT.
9   foreach  $s_i'$  in  $C_{s_i}$  do
10     $x_i' \leftarrow s_1 s_2 \dots s_i' \dots s_m$  // Equation 5
11     $\Delta P_i \leftarrow P(y|x) - P(y|x_i')$  // Equation 6
12  end
13   $\Delta P_i^* \leftarrow \max\{\Delta P_{ik}\}_{k=1}^{\text{len}(C_{s_i})}$  // Equation 8
14   $s_i^* \leftarrow \arg \max_{s_i' \in C_{s_i}} \{\Delta P_{ik}\}_{k=1}^{\text{len}(C_{s_i})}$  // Equation 9
15   $H_i \leftarrow \text{Softmax}(S_i) \cdot \Delta P_i^*$  // Equation 12
16  Append  $(s_i^*, H_i)$  into  $L$ .
17 end
18 Sort  $L$  by the second parameter in descending order.
19 foreach  $(s_i^*, H_i)$  in  $L$  do
20    $x' \leftarrow s_1 s_2 \dots s_i^* \dots s_m$ 
21   if  $F(x') \neq F(x)$  then
22     Attack succeeds and return  $x'$ .
23   end
24 end
25 Attack fails and return.

```

Table 1: Information of Datasets

Dataset	Task	#Classes	#Average Syllables	#Average Letters	#Total Samples	#Training Samples	#Validation Samples	#Test Samples
TNCC-title	news title classification	12	15.5031	63.6196	9,276	7,422	927	927
TU_SA	sentiment analysis	2	27.8724	108.1897	10,000	8,000	1,000	1,000

Table 2: Hyperparameters of Fine-tuning

Model	Dataset	Batch Size	Epochs	Learning Rate	Warmup Ratio	Metric for Best Model
Tibetan-BERT	TNCC-title & TU_SA	32	20	5e-5	0.0	Macro-F1 & F1
CINO-small-v2	TNCC-title & TU_SA	32	40	5e-5	0.1	Macro-F1 & F1
CINO-base-v2	TNCC-title & TU_SA	32	40	5e-5	0.1	Macro-F1 & F1
CINO-large-v2	TNCC-title & TU_SA	32	40	3e-5	0.1	Macro-F1 & F1

Table 3: Model Performance on TNCC-title

Model	Accuracy	Macro-F1	Macro-Precision	Macro-Recall	Weighted-F1	Weighted-Precision	Weighted-Recall
Tibetan-BERT	0.6462	0.6057	0.6251	0.5956	0.6423	0.6450	0.6462
CINO-small-v2	0.7023	0.6839	0.6918	0.6819	0.7016	0.7069	0.7023
CINO-base-v2	0.6764	0.6488	0.6523	0.6556	0.6772	0.6853	0.6764
CINO-large-v2	0.7044	0.6759	0.6898	0.6672	0.7025	0.7062	0.7044

Bold and underlined values represent the best performance.

Bold values represent the second best performance.

Table 4: Model Performance on TU_SA

Model	Accuracy	F1	Precision	Recall
Tibetan-BERT	0.7070	0.6913	0.7305	0.6560
CINO-small-v2	0.7550	0.7818	0.7047	0.8780
CINO-base-v2	0.7530	0.7748	0.7119	0.8500
CINO-large-v2	0.7970	0.7992	0.7906	0.8080

Bold and underlined values represent the best performance.

Bold values represent the second best performance.

4.2 Evaluation Metrics

- **Accuracy Drop Value (ADV)**. *ADV* refers to the drop value of the model accuracy post-attack compared to pre-attack, as defined in Equation 13, with which we evaluate the attack effectiveness and the model robustness. The larger *ADV*, the more effective the attack, and the less robust the model.

$$ADV = Accuracy_{pre} - Accuracy_{post} \quad (13)$$

- **Attack Success Ratio (ASR)**. *ASR* refers to the ratio of the number of changes in model predictions before and after the attack, as defined in Equation 14, which we use to evaluate the attack effectiveness and the model robustness. The larger *ASR*, the more effective the attack, and the less robust the

model.

$$ASR = \frac{Num_{F(x) \neq F(x')}}{Num_{total}} \quad (14)$$

- **Levenshtein Distance (LD)**. *LD* between the original text and the adversarial text is the minimum number of single-letter edits (insertions, deletions, or substitutions) required to change one text into the other, as defined in Equation 15. We use this metric to evaluate the quality of the adversarial text, and the smaller *LD*, the better the quality of the adversarial text.

$$LD_{x,x'}(i, j) = \begin{cases} \max(i, j) & \text{if } \min(i, j) = 0, \\ LD_{x,x'}(i-1, j-1) & \text{if } x_i = x'_j, \\ 1 + \min \begin{cases} LD_{x,x'}(i-1, j) \\ LD_{x,x'}(i, j-1) \\ LD_{x,x'}(i-1, j-1) \end{cases} & \text{otherwise.} \end{cases} \quad (15)$$

4.3 Experiment Results

Cao et al. [1] propose the first Tibetan textual adversarial attack method called *TSAAttacker*, which we use as a baseline method for comparison. Table 5 and Table 6 list the performance of involved attack methods against the victim language models on the TNCC-title and TU_SA datasets, respectively. *TSTricker-s* represents syllable-level *TSTricker*, and *TSTricker-w* represents word-level *TSTricker*.

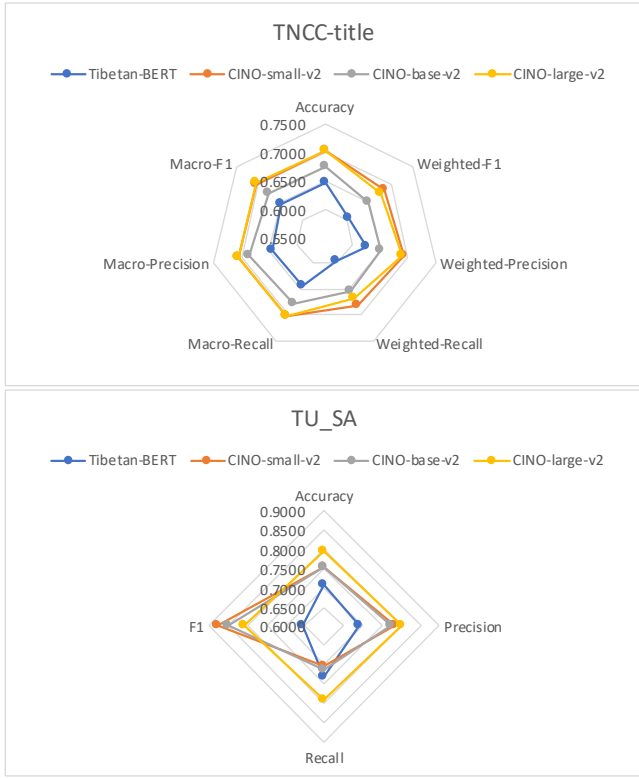

Figure 4: Performance of Victim Language Models

Figure 5 clearly depicts the attack performance. Table 7 lists several generated adversarial text.

From the perspective of ADV and ASR, *TSTricker* has a significant improvement in attack effect compared with *TSAttacker*, and both syllable-level and word-level *TSTricker* can make the model change the predictions of more than 90% of the samples. From the perspective of LD, *TSAttacker* and *TSTricker-s* are syllable-level attacks, while *TSTricker-w* is a word-level attack, so a larger attack granularity leads to a larger LD. As introduced in Subsection 2.2, the granularity of Tibetan script, from small to large, is divided into letters [or Unicodes], syllables, and words, therefore the granularity of word-level attacks is larger than syllable-level attacks. In Table 7, on TNCC-title, *TSTricker-s* and *TSTricker-w* both change the Tibetan word “traveling”, and on TU_SA, *TSTricker-s* and *TSTricker-w* both change the Tibetan word “cute”. Native Tibetan speakers find the semantics of the *TSTricker-s* generated adversarial texts not changed, while the semantics of the *TSTricker-w* generated adversarial texts changed. Also, word-level *TSTricker* depends on the effectiveness of the segmentation tool. In summary, *TSTricker-s* is a good attack method with a high attack effect and fewer perturbations, while *TSTricker-w* has larger perturbation granularity and may cause semantics change.

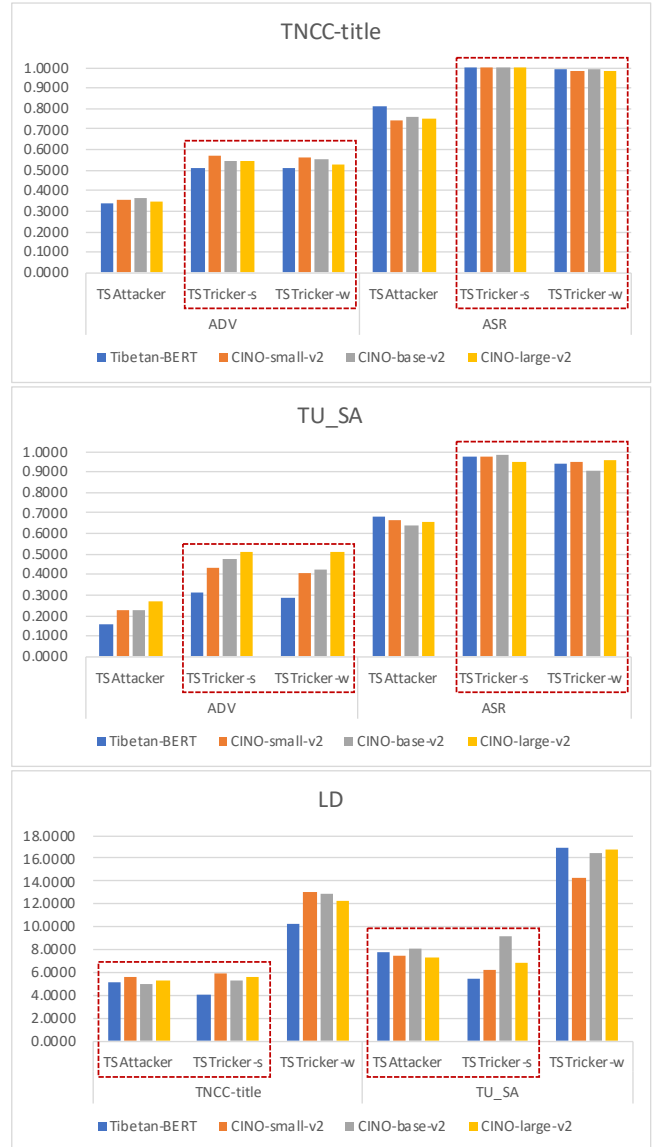

Figure 5: Performance of Attacks

5 DISCUSSION

5.1 Adversarial Attack in Social Media

In social media, neural network models have been used for hate speech detection, pornographic content detection, etc., and have achieved good results. However, adversarial content is still ubiquitous on the internet, and adversarial content can always evade detection by various means. Studying adversarial attacks in social media is crucial to purify the network. Wang et al. [18] evaluate the adversarial robustness of ChatGPT and find that even for ChatGPT, its absolute performance is far from perfection. Therefore, there is still enormous exploration room for research on the robustness and interpretability of neural network models.

Table 5: Attack Performance on TNCC-title

Metric	Attack	Tibetan-BERT	CINO-small-v2	CINO-base-v2	CINO-large-v2
ADV	TSAttacker	0.3420	0.3592	0.3646	0.3430
	TSTricker-s	<u>0.5124</u>	<u>0.5685</u>	<u>0.5414</u>	<u>0.5426</u>
	TSTricker-w	<u>0.5124</u>	<u>0.5588</u>	<u>0.5566</u>	<u>0.5286</u>
ASR	TSAttacker	0.8090	0.7400	0.7605	0.7487
	TSTricker-s	<u>0.9968</u>	<u>0.9989</u>	<u>0.9989</u>	<u>0.9978</u>
	TSTricker-w	<u>0.9957</u>	<u>0.9806</u>	<u>0.9935</u>	<u>0.9817</u>
LD	TSAttacker	<u>5.2000</u>	<u>5.6210</u>	<u>5.0638</u>	<u>5.3386</u>
	TSTricker-s	<u>4.0671</u>	<u>5.8856</u>	<u>5.3402</u>	<u>5.6865</u>
	TSTricker-w	10.2492	13.0297	12.9511	12.3374

Bold and underlined values represent the best performance.

Bold values represent the second best performance.

Table 6: Attack Performance on TU_SA

Metric	Attack	Tibetan-BERT	CINO-small-v2	CINO-base-v2	CINO-large-v2
ADV	TSAttacker	0.1570	0.2260	0.2240	0.2660
	TSTricker-s	<u>0.3080</u>	<u>0.4300</u>	<u>0.4730</u>	<u>0.5060</u>
	TSTricker-w	<u>0.2870</u>	<u>0.4050</u>	<u>0.4200</u>	<u>0.5100</u>
ASR	TSAttacker	0.6810	0.6640	0.6380	0.6570
	TSTricker-s	<u>0.9740</u>	<u>0.9780</u>	<u>0.9870</u>	<u>0.9520</u>
	TSTricker-w	<u>0.9390</u>	<u>0.9470</u>	<u>0.9060</u>	<u>0.9560</u>
LD	TSAttacker	<u>7.7298</u>	<u>7.4533</u>	<u>8.0769</u>	<u>7.3369</u>
	TSTricker-s	<u>5.4887</u>	<u>6.2495</u>	<u>9.2057</u>	<u>6.8813</u>
	TSTricker-w	16.9542	14.2365	16.5066	16.7699

Bold and underlined values represent the best performance.

Bold values represent the second best performance.

5.2 Robustness of Chinese Minority Language Models

Due to the lag of Chinese minority natural language processing technology, the conditions for studying the robustness of Chinese minority language models have just matured. Textual adversarial attack is a new challenge. China is a unified multi-ethnic country, and studying textual adversarial attacks plays an important role in the informatization construction and stable development of ethnic minority areas in China.

6 CONCLUSION AND FUTURE WORK

This paper proposes a multi-granularity Tibetan textual adversarial attack method based on masked language models called *TSTricker*, which can reduce the accuracy of the victim models by more than 28.70% and make the victim models change the predictions of more than 90.60% of the samples. This attack method has an evidently higher attack effect than the baseline method. In particular, syllable-level *TSTricker* performs excellently in attack effectiveness, perturbation ratio, and semantics preservation. However, word-level *TSTricker* may not perform well at the level of perturbation ratio and semantics preservation. It does not mean that adversarial attacks closer to real attack scenarios are more useful, as white-box

adversarial attacks and soft-label black-box adversarial attacks have been used to reinforce models before they go live. Accordingly, we believe that *TSTricker-s* can be well applied to Tibetan NLP models' reinforcement scenarios.

We will divide future work into two parts. Part of it is active defense, and we will explore more Tibetan textual adversarial attack methods to generate a Tibetan adversarial dataset and construct a Tibetan textual adversarial attack toolkit. On the one hand, the dataset can be used to evaluate the robustness of Tibetan language models, and on the other hand, the toolkit can be used for adversarial training to improve the robustness of Tibetan language models. The other part is to explore hard-label or more efficient textual adversarial attack methods, providing theoretical guidance for active defense.

7 ETHICS STATEMENT

This paper aims to demonstrate the effectiveness of our attack method and the vulnerability in the robustness of the models involved. We hope to drive the active defense of related language models and hope that this attack method is not abused. We call more attention to the security issues in the information processing of Chinese minority languages.

Table 7: Several Generated Adversarial Texts

Dataset	Text	Class
TNCC-title	Original Text: ལྷོ་མི་ལུ་ཡར་ལྷོད་པའི་ཀྱང་གོ་བའི་བས་བོད་ལྗོངས་སུ་ཡུལ་ལྷོད་བྱེད་སྐབས་ཀྱི་ཕྱིང་ཚར་བཞིན་པ།	Tourism (99.5900%)
	English Translation: Chinese in Australia talking about their feelings when traveling in Xizang.	
	TSTricker-s Generated Adversarial Text: ལྷོ་མི་ལུ་ཡར་ལྷོད་པའི་ཀྱང་གོ་བའི་བས་བོད་ལྗོངས་སུ་ཡུལ་ལྷོད་བྱེད་སྐབས་ཀྱི་ཕྱིང་ཚར་བཞིན་པ།	Politics (55.0304%)
	TSTricker-w Generated Adversarial Text: ལྷོ་མི་ལུ་ཡར་ལྷོད་པའི་ཀྱང་གོ་བའི་བས་བོད་ལྗོངས་སུ་མ་བྱེད་སྐབས་ཀྱི་ཕྱིང་ཚར་བཞིན་པ།	Politics (94.4312%)
TU_SA	Original Text: མེ་དབུང་ལན་གྱི་མཚོན་རྟགས་རང་བཞིན་གྱི་སྐྱ་ལ་བལྟས་མ་གཤམས་མོང་འདྲི་དག་ནི་ལྷུ་མེ་དང་པའི་ཚོགས་པའི་ནང་གི་གྲོགས་མོ་ཡིན་ནམ། ཉ་ཉ་ཟ་ཟ་བ་བཞིན་འདུག་ལྷོད་མོ་འདུག།	Positive (99.9726%)
	English Translation: Yanglan Mei’s iconic hair is evident at a glance. Are these the best friends in the First Lady circle? Haha, everyone is eating, it’s incredibly cute.	
	TSTricker-s Generated Adversarial Text: མེ་དབུང་ལན་གྱི་མཚོན་རྟགས་རང་བཞིན་གྱི་སྐྱ་ལ་བལྟས་མ་གཤམས་མོང་འདྲི་དག་ནི་ལྷུ་མེ་དང་པའི་ཚོགས་པའི་ནང་གི་གྲོགས་མོ་ཡིན་ནམ། ཉ་ཉ་ཟ་ཟ་བ་བཞིན་འདུག་ལྷོད་མོ་འདུག།	Negative (99.6808%)
	TSTricker-w Generated Adversarial Text: མེ་དབུང་ལན་གྱི་མཚོན་རྟགས་རང་བཞིན་གྱི་སྐྱ་ལ་བལྟས་མ་གཤམས་མོང་འདྲི་དག་ནི་ལྷུ་མེ་དང་པའི་ཚོགས་པའི་ནང་གི་གྲོགས་མོ་ཡིན་ནམ། ཉ་ཉ་ཟ་ཟ་བ་བཞིན་འདུག་དམོ་འདུག།	Negative (99.8371%)

ACKNOWLEDGMENTS

We would like to express our sincere gratitude to the following funding sources for their support of this article: the “New Generation Artificial Intelligence” Major Project of Science and Technology Innovation 2030 (No. 2022ZD0116100), the Key Project of Natural Science Foundation of Tibet Autonomous Region “Research on Adversarial Attack and Defense for Tibetan Natural Language Processing Models” in 2024, and the Graduate “High-level Talents Cultivation Program” Project of Tibet University (No. 2021-GSP-S125).

REFERENCES

- [1] Xi Cao, Dolma Dawa, Nuo Qun, and Trashi Nyima. 2023. Pay Attention to the Robustness of Chinese Minority Language Models! Syllable-level Textual Adversarial Attack on Tibetan Script. In *Proceedings of the 3rd Workshop on Trustworthy Natural Language Processing (TrustNLP 2023)*, Anaëlia Ovalle, Kai-Wei Chang, Ninareh Mehrabi, Yada Pruksachatkun, Aram Galystan, Jwala Dhamala, Apurv Verma, Trista Cao, Anoop Kumar, and Rahul Gupta (Eds.). Association for Computational Linguistics, Toronto, Canada, 35–46. <https://doi.org/10.18653/v1/2023.trustnlp-1.4>
- [2] Junjie Deng, Hanru Shi, Xinhe Yu, Wugede Bao, Yuan Sun, and Xiaobing Zhao. 2023. MiLMo: Minority Multilingual Pre-Trained Language Model. In *2023 IEEE International Conference on Systems, Man, and Cybernetics (SMC)*. 329–334. <https://doi.org/10.1109/SMC53992.2023.10393961>
- [3] Javid Ebrahimi, Anyi Rao, Daniel Lowd, and Dejing Dou. 2018. HotFlip: White-Box Adversarial Examples for Text Classification. In *Proceedings of the 56th Annual Meeting of the Association for Computational Linguistics (Volume 2: Short Papers)*, Iryna Gurevych and Yusuke Miyao (Eds.). Association for Computational Linguistics, Melbourne, Australia, 31–36. <https://doi.org/10.18653/v1/P18-2006>
- [4] Steffen Eger, Gözde Gül Şahin, Andreas Rücklé, Ji-Ung Lee, Claudia Schulz, Mohsen Mesgar, Krishnkant Swarnkar, Edwin Simpson, and Iryna Gurevych. 2019. Text Processing Like Humans Do: Visually Attacking and Shielding NLP Systems. In *Proceedings of the 2019 Conference of the North American Chapter of the Association for Computational Linguistics: Human Language Technologies, Volume 1 (Long and Short Papers)*, Jill Burstein, Christy Doran, and Thamar Solorio (Eds.).

- Association for Computational Linguistics, Minneapolis, Minnesota, 1634–1647. <https://doi.org/10.18653/v1/N19-1165>
- [5] Ian J. Goodfellow, Jonathon Shlens, and Christian Szegedy. 2015. Explaining and Harnessing Adversarial Examples. In *3rd International Conference on Learning Representations, ICLR 2015, San Diego, CA, USA, May 7-9, 2015, Conference Track Proceedings*, Yoshua Bengio and Yann LeCun (Eds.). <http://arxiv.org/abs/1412.6572>
- [6] Ziyi Han, Wei Wang, and Shichang Xuan. 2023. Chinese Adversarial Example Generation Guided by Multi-constraints. *Journal of Chinese Information Processing* 37, 2 (2023), 41–52. <http://jcip.cipsc.org.cn/CN/Y2023/V37/I2/41>
- [7] Robin Jia and Percy Liang. 2017. Adversarial Examples for Evaluating Reading Comprehension Systems. In *Proceedings of the 2017 Conference on Empirical Methods in Natural Language Processing*, Martha Palmer, Rebecca Hwa, and Sebastian Riedel (Eds.). Association for Computational Linguistics, Copenhagen, Denmark, 2021–2031. <https://doi.org/10.18653/v1/D17-1215>
- [8] Di Jin, Zhijing Jin, Joey Tianyi Zhou, and Peter Szolovits. 2020. Is BERT Really Robust? A Strong Baseline for Natural Language Attack on Text Classification and Entailment. In *The Thirty-Fourth AAAI Conference on Artificial Intelligence, AAAI 2020, The Thirty-Second Innovative Applications of Artificial Intelligence Conference, IAAI 2020, The Tenth AAAI Symposium on Educational Advances in Artificial Intelligence, EAAI 2020, New York, NY, USA, February 7-12, 2020*. AAAI Press, 8018–8025. <https://doi.org/10.1609/AAAI.V34I05.6311>
- [9] Bin Li, Yixuan Weng, Bin Sun, and Shutao Li. 2022. A Multi-tasking and Multi-stage Chinese Minority Pre-trained Language Model. In *Machine Translation - 18th China Conference, CCMT 2022, Lhasa, China, August 6-10, 2022, Revised Selected Papers (Communications in Computer and Information Science, Vol. 1671)*, Tong Xiao and Juan Pino (Eds.). Springer, 93–105. https://doi.org/10.1007/978-981-19-7960-6_10
- [10] Jiwei Li, Will Monroe, and Dan Jurafsky. 2016. Understanding Neural Networks through Representation Erasure. *CoRR* abs/1612.08220 (2016). [arXiv:1612.08220](http://arxiv.org/abs/1612.08220) <http://arxiv.org/abs/1612.08220>
- [11] Xiangge Li, Hong Luo, and Yan Sun. 2023. Adversarial Sample Generation Method Based on Chinese Features. *Journal of Software* 34, 11 (2023), 5143–5161. <https://doi.org/10.13328/j.cnki.jos.006744>
- [12] Han Liu, Zhi Xu, Xiaotong Zhang, Xiaoming Xu, Feng Zhang, Fenglong Ma, Hongyang Chen, Hong Yu, and Xianchao Zhang. 2023. SSPAttack: A Simple and Sweet Paradigm for Black-Box Hard-Label Textual Adversarial Attack. In *Thirty-Seventh AAAI Conference on Artificial Intelligence, AAAI 2023, Thirty-Fifth Conference on Innovative Applications of Artificial Intelligence, IAAI 2023, Thirteenth Symposium on Educational Advances in Artificial Intelligence, EAAI 2023, Washington, DC, USA, February 7-14, 2023*, Brian Williams, Yiling Chen, and

- Jennifer Neville (Eds.). AAAI Press, 13228–13235. <https://doi.org/10.1609/AAAI.V37I11.26553>
- [13] Sisi Liu, Junjie Deng, Yuan Sun, and Xiaobing Zhao. 2022. TiBERT: Tibetan Pre-trained Language Model. In *2022 IEEE International Conference on Systems, Man, and Cybernetics (SMC)*. 2956–2961. <https://doi.org/10.1109/SMC53654.2022.9945074>
- [14] Rishabh Maheshwary, Saket Maheshwary, and Vikram Pudi. 2021. Generating Natural Language Attacks in a Hard Label Black Box Setting. In *Thirty-Fifth AAAI Conference on Artificial Intelligence, AAAI 2021, Thirty-Third Conference on Innovative Applications of Artificial Intelligence, IAAI 2021, The Eleventh Symposium on Educational Advances in Artificial Intelligence, EAAI 2021, Virtual Event, February 2-9, 2021*. AAAI Press, 13525–13533. <https://doi.org/10.1609/AAAI.V35I15.17595>
- [15] Nuo Qun, Xing Li, Xipeng Qiu, and Xuanjing Huang. 2017. End-to-End Neural Text Classification for Tibetan. In *Chinese Computational Linguistics and Natural Language Processing Based on Naturally Annotated Big Data - 16th China National Conference, CCL 2017, - and - 5th International Symposium, NLP-NABD 2017, Nanjing, China, October 13-15, 2017, Proceedings (Lecture Notes in Computer Science, Vol. 10565)*, Maosong Sun, Xiaojie Wang, Baobao Chang, and Deyi Xiong (Eds.). Springer, 472–480. https://doi.org/10.1007/978-3-319-69005-6_39
- [16] Shuhuai Ren, Yihe Deng, Kun He, and Wanxiang Che. 2019. Generating Natural Language Adversarial Examples through Probability Weighted Word Saliency. In *Proceedings of the 57th Annual Meeting of the Association for Computational Linguistics*, Anna Korhonen, David Traum, and Lluís Màrquez (Eds.). Association for Computational Linguistics, Florence, Italy, 1085–1097. <https://doi.org/10.18653/v1/P19-1103>
- [17] Christian Szegedy, Wojciech Zaremba, Ilya Sutskever, Joan Bruna, Dumitru Erhan, Ian J. Goodfellow, and Rob Fergus. 2014. Intriguing properties of neural networks. In *2nd International Conference on Learning Representations, ICLR 2014, Banff, AB, Canada, April 14-16, 2014, Conference Track Proceedings*, Yoshua Bengio and Yann LeCun (Eds.). <http://arxiv.org/abs/1312.6199>
- [18] Jindong Wang, Xixu Hu, Wenxin Hou, Hao Chen, Runkai Zheng, Yidong Wang, Linyi Yang, Haojun Huang, Wei Ye, Xiubo Geng, Binxing Jiao, Yue Zhang, and Xing Xie. 2023. On the Robustness of ChatGPT: An Adversarial and Out-of-distribution Perspective. *CoRR* abs/2302.12095 (2023). <https://doi.org/10.48550/ARXIV.2302.12095> arXiv:2302.12095
- [19] Wenqi Wang, Run Wang, Lina Wang, and Benxiao Tang. 2019. Adversarial examples generation approach for tendency classification on Chinese texts. *Journal of Software* 30, 8 (2019), 2415–2427. <https://doi.org/10.13328/j.cnki.jos.005765>
- [20] Ziqing Yang, Zihang Xu, Yiming Cui, Baoxin Wang, Min Lin, Dayong Wu, and Zhigang Chen. 2022. CINO: A Chinese Minority Pre-trained Language Model. In *Proceedings of the 29th International Conference on Computational Linguistics*, Nicoletta Calzolari, Chu-Ren Huang, Hansaem Kim, James Pustejovsky, Leo Wanner, Key-Sun Choi, Pum-Mo Ryu, Hsin-Hsi Chen, Lucia Donatelli, Heng Ji, Sadao Kurohashi, Patrizia Paggio, Nianwen Xue, Seokhwan Kim, Younggyun Hahm, Zhong He, Tony Kyungil Lee, Enrico Santus, Francis Bond, and Seung-Hoon Na (Eds.). International Committee on Computational Linguistics, Gyeongju, Republic of Korea, 3937–3949. <https://aclanthology.org/2022.coling-1.346>
- [21] Muchao Ye, Chenglin Miao, Ting Wang, and Fenglong Ma. 2022. TextHoaxer: Budgeted Hard-Label Adversarial Attacks on Text. In *Thirty-Sixth AAAI Conference on Artificial Intelligence, AAAI 2022, Thirty-Fourth Conference on Innovative Applications of Artificial Intelligence, IAAI 2022, The Twelfth Symposium on Educational Advances in Artificial Intelligence, EAAI 2022 Virtual Event, February 22 - March 1, 2022*. AAAI Press, 3877–3884. <https://doi.org/10.1609/AAAI.V36I4.20303>
- [22] Jiangyan Zhang, Deji Kazhuo, Luosang Gadeng, Nyima Trashi, and Nuo Qun. 2022. Research and Application of Tibetan Pre-training Language Model Based on BERT. In *Proceedings of the 2nd International Conference on Control and Intelligent Robotics, ICCIR 2022, Nanjing, China, June 24-26, 2022*. ACM, 519–524. <https://doi.org/10.1145/3548608.3559255>
- [23] Shunxiang Zhang, Houyue Wu, Guangli Zhu, Xin Xu, and Mingxing Su. 2023. Character-level Adversarial Samples Generation Approach for Chinese Text Classification. *Journal of Electronics & Information Technology* 45, 6 (2023), 2226–2235. <https://doi.org/10.11999/JEIT220563>
- [24] Yulei Zhu, Kazhuo Deji, Nuo Qun, and Tashi Nyima. 2023. Sentiment Analysis of Tibetan Short Texts Based on Graphical Neural Networks and Pre-training Models. *Journal of Chinese Information Processing* 37, 2 (2023), 71–79. <http://jcip.cipsc.org.cn/CN/Y2023/V37/I2/71>