

An Exploratory Study on Fine-Tuning Large Language Models for Secure Code Generation

Junjie Li · Fazle Rabbi · Cheng Cheng ·
Aseem Sangalay · Yuan Tian · Jinqiu Yang

Received: date / Accepted: date

Abstract AI-powered coding assistants such as GitHub’s Copilot and OpenAI’s ChatGPT have achieved notable success in automating code generation. However, these tools rely on pre-trained Large Language Models (LLMs) that are typically trained on human-written code sourced from open-source project hosting sites like GitHub, which often contains inherent security vulnerabilities. These vulnerabilities may then be mirrored in the code generated by these LLMs, a critical risk revealed and highlighted by recent empirical studies. In this work, we present an exploratory study on whether fine-tuning pre-trained LLMs on datasets of vulnerability-fixing commits can promote secure code generation.

We explored two parameter-efficient fine-tuning techniques (LoRa and IA3) on two pre-trained LLMs for code generation. We crawled a fine-tuning dataset (14,622 C/C++ files) for secure code generation by collecting code fixes of confirmed vulnerabilities from open-source repositories. Our evaluation dataset comprises 52 vulnerability scenarios designed to cover the top most dangerous C/C++ Common Weakness Enumerations (CWEs). Each scenario is a prompt that may

Junjie Li
Concordia University
E-mail: ljunjie@encs.concordia.ca

Fazle Rabbi
Concordia University
E-mail: fazle.rabbi@mail.concordia.ca

Cheng Cheng
Concordia University
E-mail: cheng.cheng@concordia.ca

Aseem Sangalay
Delhi Technological University
E-mail: aseemsangalay@gmail.com

Yuan Tian
Queen’s University
E-mail: y.tian@queensu.ca

Jinqiu Yang
Concordia University
E-mail: jinqiu.yang@concordia.ca

induce LLMs to generate vulnerable code. Our exploration reveals that fine-tuning LLMs can improve secure code generation by 6.4% in C language and 5.4% in C++ language. We further experimented with fine-tuning LLMs using different versions of the collected secure code dataset (block, function, and line). We found that fine-tuning with function-level and block-level datasets achieves the best secure code generation performance, compared to the alternatives (file-level and line-level). In addition, we investigate the impact of the size of the fine-tuning dataset on secure code generation. With the increasing size of the fine-tuning dataset, the model can produce more valid and secure code. Finally, our experiment shows that the LLMs fine-tuned for secure code generation do not have performance degradation in terms of generating correct code. For CodeLlama, we even observed an improvement of 2% in terms of the PASS@1 under the HumanEval CPP benchmark with secure fine-tuning.

Keywords Code Generation · Cybersecurity · Artificial Intelligence (AI) · Common Weakness Enumerations (CWEs) · Large Language Models (LLMs)

1 Introduction

Large Language Models (LLMs) trained on huge corpus are significantly advancing various software engineering tasks, including code and comment generation [2, 28], program repair [20, 21], and bug detection [46]. Specifically in code generation, GPT-4 Turbo has achieved a score of 85.4% on the pass@1 metric of the widely recognized HumanEval [6] code generation benchmark. Similarly, a recent open-source LLM, MagicoderS-CL, has scored a pass@1 of 70.7% on the same benchmark [44].

Despite the great success of LLMs for code generation, researchers have found many quality concerns with such automatically generated code. One of the most severe concerns is that automatically-generated code by LLMs often contains vulnerabilities. Pearce et al. [33] found that 40% of the generated code snippets by Copilot are vulnerable in a benchmark of security-sensitive scenarios. Security-sensitive scenarios are incomplete code snippets and may trigger LLMs to generate vulnerable code when completing these code snippets. Figure 1a shows an example of a security-sensitive scenario (prompt). This scenario is manually crafted for illustrating CWE-787 (Out-of-bounds Write)¹. Figure 1b and Figure 1c are two code snippets generated by Copilot based on the prompt shown in Figure 1a.² Figure 1b shows an example of secure code, where the string format “%2.3f” limits the length of a floating-point number, mitigating the risk of an out-of-bounds vulnerability. Conversely, the code in Figure 1c does not limit the length of a floating-point number, making it vulnerable. As AI programming assistant tools

¹ This CWE is one of the most dangerous software weaknesses. It occurs when the software writes the data past the end, or before the beginning of the intended buffer. Usually, this unintended overwrite can result in the corruption of data, program crashes, or incorrect execution of code [1].

² Copilot’s configuration allows users to set the number of candidate suggestions it provides, with a default of one. In this instance, the setting is configured to 25, ensuring that Copilot generates a diverse set of top 25 code candidates for each scenario. The two samples shown were selected from these 25 candidates.

```

1 int main(int argc, char *argv[]) {
2     //generate 3 random floats
3     float a = (float)rand() / (float)RAND_MAX;
4     float b = (float)rand() / (float)RAND_MAX;
5     float c = (float)rand() / (float)RAND_MAX;
6
7     //convert to string

```

(a) An example scenario for evaluating if LLMs may generate vulnerable code.

```

1 char f1[30], f2[30], f3[30];
2 sprintf(f1, "%2.3f", a);
3 sprintf(f2, "%2.3f", b);
4 sprintf(f3, "%2.3f", c);

```

(b) A non-vulnerable case generated by Copilot.

```

1 char str_a[20], str_b[20], str_c[20];
2 sprintf(str_a, "%f", a);
3 sprintf(str_b, "%f", b);
4 sprintf(str_c, "%f", c);

```

(c) A vulnerable case generated by Copilot

Fig. 1: An example prompt with vulnerable and non-vulnerable code generated by Copilot.

like Copilot become increasingly popular and have been integrated into developers' workflows, it is critical to improve the quality of code generation by LLMs, particularly regarding security.

There have been several attempts to promote the generation of secure code by LLMs. Classic vulnerability detection and repair techniques can be applied to detect and fix vulnerabilities [8]. An alternative direction is to improve LLMs through fine-tuning techniques. He et al. [17] propose a fine-tuning technique based on prefix tuning for LLMs that aims to reduce the generation of vulnerable code. This work is limited to one LLM, i.e., CodeGen [31] with 2.7B parameters, and considers specific vulnerabilities (only 9 CWEs) for evaluation. Our prior work [26] fine-tuned GPT-J using the 4,900 vulnerability-fixing commits. However, the full potential of fine-tuned LLMs for secure code generation has not yet been extensively explored. In particular, our previous study was limited in scope, focusing only on a single model and dataset. Therefore, there is a need for further research to (1) experiment with a variety of fine-tuning techniques, (2) experiment with diverse LLMs, (3) investigate the impact of fine-tuning datasets in terms of granularity and size on the performance of fine-tuned LLMs, and (4) validate whether the fine-tuned LLMs for better security still have comparable performance in terms of functional correctness. In other words, fine-tuning LLMs for security purposes does not compromise their ability to generate functionally correct code. To address these gaps, the work aim to provide a comprehensive understanding of whether fine-tuning LLMs would lead to secure code generation in this work. We extend our previous reserach by experimenting with two LLMs (CodeGen2 and CodeLlama) for code generation and leveraging two fine-tuning techniques, i.e., LoRA [19] and IA3 [27]. Additionally, we try different granularities of the fine-tuning sets. They are file-level, function-level, and block-level, and line-level.

To achieve our goal, we followed a five-step process. *First*, we curated a dataset of 4,900 vulnerability-fixing commits from 580 open-source projects, sourcing from three widely-used vulnerability datasets [3, 5, 11] as our fine-tuning dataset. *Second*, we chose CodeLlama [36], and CodeGen2 [30] as the base LLMs for our study and fine-tuned these models using two parameter-efficient fine-tuning (PEFT) techniques, i.e., LoRA and IA3. *Third*, to evaluate the LLMs’ capability in generating secure code, we created 29 security-sensitive scenarios, in addition to reusing the 23 scenario dataset proposed by Pearce et al. [33]. In total, there are 52 security-sensitive scenarios. These scenarios cover the top 11 CWE (MITRE’s Common Weakness Enumerations) from the “2022 CWE Top 25 Most Dangerous Software Weaknesses” list³. *Fourth*, we utilized a static vulnerability detection tool, CodeQL [8], to identify vulnerabilities in the generated code by LLMs. After getting the vulnerability results, we conducted a comparative evaluation between the pre-trained and their fine-tuned versions. Furthermore, we assessed the impact of different fine-tuning datasets, specifically focusing on granularity and size, on the performance of the fine-tuned LLMs in generating secure code. *Finally*, we evaluated the functional correctness of code generated by the pre-trained and fine-tuned models using the HumanEval_CPP benchmark [49]. Our exploratory study addresses the following four research questions (RQs):

- **RQ1: Can fine-tuning LLMs with secure source code reduce vulnerable code by LLMs?** We leveraged two popular PEFT techniques, LoRA and IA3 to fine-tune CodeLlama and CodeGen2. Our experiment reveals that fine-tuned LLMs have an improved secure ratio for code generation in C and C++. For example, CodeGen2 (fine-tuned by LoRa) improves the percentage of secure code from 56% to 62.4%.
 - **RQ2: How the granularity of fine-tuning dataset may impact fine-tuning LLMs for secure code generation?** For each LLM and PEFT technique, we experimented with four fine-tuning datasets with diverse granularity, i.e., file-level, method-level, block-level, and line-level, to fine-tuning the model. We found that by using block-level and function-level fine-tuning datasets the two models achieve the highest secure ratio with 60.7% and 65.1% for C and C++ in the fine-tuned CodeLlama.
 - **RQ3: How the size of fine-tuning dataset may impact fine-tuning LLMs for secure code generation?** Similar to RQ2, we evaluated whether fine-tuning datasets of different sizes will yield fine-tuned LLMs with different performances in secure code generation. We find that, by increasing the size of the dataset, the models can generate more secure code snippets from 62.5% to 79.2% in C using LoRa for CodeGen2.
 - **RQ4: Does fine-tuning LLMs for security impact the performance of LLMs in generating correct code?** We evaluated the performance of the fine-tuned LLMs in generating correct code using the HumanEval_CPP dataset [49]. We found that the fine-tuned LLMs for secure code generation do not have significant performance degradation in generating correct code. Several of the fine-tuned LLMs from CodeGen2 for C++ even show improvements on PASS@1.
- Our work makes the following contributions.
- We present a comprehensive exploration on using fine-tuning techniques for improving the security aspect of LLM-based code generation.

³ https://cwe.mitre.org/top25/archive/2022/2022_cwe_top25.html

- We experimented with a variety of dataset versions (in terms of granularity and size) to fine-tune LLMs and evaluate the impacts on generating secure and functionally correct code. We found that using LoRa to fine-tune block-level and function-level data sets achieves the highest performance in C and C++ languages, with 6.7% and 5.4% improvements, respectively. Besides, the functional correctness of our fine-tuned models does not have a significant decrease compared to the pre-trained ones.
- We release a replication package⁴

The rest of the paper is organized as follows: Section 2 presents the related work. Section 3 presents in detail our selected subjects (the LLMs and the datasets selected for fine-tuning, and the prompt dataset for evaluation) in this work. In Section 4, we overview our experiment design and describe the detailed configurations/settings we used for fine-tuning LLMs and using the fine-tuned LLMs for secure code generation. Section 5 presents the motivation, approach, and results of three research questions. Section 6 discusses the internal and external threats in this study. Finally, Section 7 concludes the entire study with findings.

2 Background and Related Work

2.1 Large Language Models (LLMs) for Code Generation

There has been increasing interest in using pre-trained LLMs for code generation and completion. So far, three types of LLMs have been adopted to generate and complete code automatically, namely decoding-only language models, masked language models (MLMs), and encoder-decoder models. One of the most popular examples in decoding-only models is GPT and its series (GPT2, GPT-3, GPT-3.5, and GPT-4) by OpenAI. Besides, GPT-J (6B) [40], Codex (12B) [6], CodeGen [31, 30] and CodeLLaMA [36] are decoding-only models, which generate the code according to the previously given tokens. CuBERT (345B) [22], CodeBERT (125M) [12], and InCoder [13] are MLMs, which target on predicting the masked code according to the code context around the masked pieces. CodeT5 (220M) [43] is an encoder-decoder model, where an input sequence was read in entirety and encoded to an internal representation and decoded to generate an output sequence leveraging a decoding-only model.

2.2 Security Issue in LLM-generated Code

Although LLMs offer significant potential for automating code generation, they are mostly trained on unsanitized data from open-source repositories hosted on GitHub. This practice neglects explicit considerations for security, thereby increasing the risk of propagating existing security vulnerabilities through the generated code. Researchers have highlighted the security risks associated with code generated by LLMs. For instance, Pearce et al. [33] evaluated GitHub Copilot, which is based on the OpenAI Codex model, and reported that approximately 40% of the generated code was insecure. Khoury et al. [23] analyzed security-relevant coding

⁴ https://github.com/SecureLLM/Secure_LLM

scenarios with ChatGPT, finding that it produced insecure code in 16 cases, of which only 7 were corrected after further interaction with the model. Moreover, Perry et al. [34] indicated that developers assisted by AI models tend to introduce more security vulnerabilities than those who do not use such tools.

To mitigate these problems, recent studies have focused on using security-aware prompts to improve the models’ ability to detect and rectify vulnerabilities in generated code. Hajipour et al. [16] proposed a method to systematically study the security issues of code language models to assess their susceptibility to generating vulnerable code via prompts. Pearce et al. [33] demonstrated that with carefully designed prompts, models are capable of generating secure fixes for identified bugs. Similarly, Wang et al. [42] designed another prompt template where problem descriptions emphasize the importance of recognizing and addressing the vulnerability in the code. However, these approaches have limitations, as they heavily depend on the user’s ability or the LLM’s ability to identify and describe the security issues accurately. He and Vechev[17] introduced SVEN, an advanced prompting method, i.e., prefix-tuning, that uses property-specific continuous vectors (prefixes) within prompts to steer code generation towards desired security properties. The training of SVEN optimizes these continuous vectors by enforcing specialized loss terms on different regions of code, using a carefully curated high-quality dataset. However, as these methods do not alter model parameters, they do not address the underlying challenge of improving the model’s intrinsic capability of generating secure code. Li et al. [26] proposed an approach to fine-tune one LLM by using the vulnerability-fixing commits. However, they only considered one LLM and did not explore the other fine-tuning techniques i.e., parameter efficient fine-tuning.

2.3 Parameter-Efficient Fine-Tuning LLMs

When applying LLMs on specific downstream tasks, there are two general approaches: 1) *fine-tuning*: continuously train the LLM on the dataset of the downstream task for a few more epochs, and 2) *in-context learning (ICL)*: instructing the model on what it is expected to do, and if necessary, adding a few examples in the instruction to make the task clearer. While ICL showcases the emerging capabilities of LLMs, the technique’s full potential often becomes more apparent through fine-tuning [35]. ICL operates during model inference and does not adjust task-specific parameters, which can limit the model’s ability to grasp detailed task nuances, potentially diminishing effectiveness. Moreover, it is highly sensitive to the quality of the instructions (prompts). In contrast, fine-tuning tailors the LLM to specific tasks by updating model parameters, enabling it to acquire and integrate detailed contextual information, producing more relevant content. However, fine-tuning is computationally intensive. Full fine-tuning updates all parameters of an LLM, requiring substantial computational power, particularly for models with billions of parameters. To mitigate these demands, *Parameter-Efficient Fine-Tuning (PEFT)* techniques have been developed, offering a cost-effective alternative while allowing the model to adapt to task-specific nuances. Specifically, PEFT techniques optimize the fine-tuning process of LLMs by selectively updating a subset of parameters instead of updating the entire model’s parameters.

Research in LLM-based code intelligence [7, 41, 45] has shown that PEFT often outperforms complete fine-tuning across various applications.

PEFT techniques optimize learning by adjusting a minimal set of parameters specifically for the intended task. This is achieved through various methods, such as integrating additional layers [18], inserting prepended tokens [25], or breaking down weight gradients into specific matrices [19]. The most popular and representative PEFT method is LOw-Rank Adaptation of LLMs (LoRA) [19], which minimizes trainable parameters by freezing the existing model weights and incorporating low-rank matrices that are trainable into the attention mechanisms of the Transformer architecture. We employ LoRA as one of our considered PEFT techniques since it has been widely used in NLP [39] and, more recently, code generation [45] and showed promising performance. Additionally, we implement IA3 [27], which builds on LoRA’s principles to further minimize the number of trainable parameters, aiming for even more efficient model adaptation.

2.4 Datasets of Vulnerabilities and Fixes

Vulnerability databases play a crucial role in analyzing vulnerabilities and evaluating automated approaches (e.g., vulnerability detection and repair) as they collect, maintain, and disseminate information on security vulnerabilities. The National Vulnerability Database (NVD) [32] is the most comprehensive publicly accessible repository of vulnerabilities. NDV is built upon Common Vulnerability and Exposures (CVE) [9] entries, which provide a unique identifier for each security flaw, facilitating the sharing of information across different entities. Many studies leverage NVD reports and CVE entries to create datasets for data-driven approaches to vulnerability detection and prediction [37]. Additionally, the Common Weakness Enumeration (CWE) [10], maintained by MITRE, categorizes types of weaknesses in software and hardware, using a tree-like architecture to link related vulnerabilities. In NDV, the identified CVE of one project can be linked to CWE to indicate the category of weakness.

Several datasets have been curated for automated vulnerability repair [14, 15] to train and evaluate these technologies. In this study, we consider the most widely used and recent vulnerability-fixing datasets, including BigVul [11], CVEfixes [3], and AndroidCVEfixes [5]. The BigVul dataset [11] includes 3,754 code vulnerabilities from 348 projects, detailing vulnerabilities and code changes over a period from 2002 to 2019. The dataset was collected from open-source GitHub projects and the NVD CVE database, linking code changes with CVE descriptive information. The other two datasets were created using a similar methodology. CVEfixes [3] offers a comprehensive view of vulnerabilities up to the source code level, with entries categorized by CWE types and CVSS severity scores, covering records up to June 2021. The AndroidCVEfixes [5] dataset focuses on the Android Open Source Project (AOSP), encompassing over 1,900 vulnerabilities complete with detailed metadata and patches.

3 Study Subjects and Datasets

In this section, we describe the study subjects and datasets in detail, including two LLMs for code generation (i.e., CodeLlama, and CodeGen2), a collection of real-world secure code (i.e., vulnerability fixes) as the fine-tuning dataset, and an evaluation dataset for evaluating the security aspects of LLM-based code generation.

3.1 Selected Large Language Models

Among the many LLMs [43, 47] available for code generation, we select two representative medium-size LLMs with around 7 billion parameters: CodeGen2-7B[30], and CodeLlama-7B[36]. These models are designed for code generation and strike a balance between computational efficiency and performance.

CodeGen2 [30] is a family of autoregressive language models that focus on the program synthesis, trained on a dataset named “The Stack” [24]. The authors provide four versions (1B, 3.7B, 7B, and 16B) of CodeGen2. We select the 7B version of CodeGen2 in this study.

CodeLlama [36] has the same architecture as Llama 2 [38] but is further trained specifically on code, infilling code, and human instruction datasets by Meta, aiming at programming tasks. It also supports long input contexts with 100,000 tokens. It provides three versions of parameters (7B, 13B, 34B) with three different variants (i.e., CodeLlama base model for general code generation, CodeLlam-Python for Python code, and CodeLlam-Instruct for safely using in coding assistant). We select the 7B version of CodeLlama in this study.

3.2 A Dataset of Secure Code for Fine-Tuning

The key idea of our approach is to compile a dataset of secure coding practices to enable LLMs to learn and replicate these patterns effectively. A source code file without vulnerabilities doesn’t necessarily contribute to teaching secure practices, especially if it lacks vulnerability-prone code or APIs. For instance, a C file comprised solely of `printf` statements, while free of vulnerabilities, offers no insight into secure coding techniques. Therefore, **when creating the dataset used for fine-tuning, we target source code files from open-source projects that specifically include fixes for known vulnerabilities.** This approach ensures that the dataset directly enhances the LLMs’ capability to generate secure code.

We create our fine-tuning datasets by combining information from three widely used and most recent vulnerability-fixing datasets, i.e., BigVul [11], CVEfixes [3], and AndroidCVEfixes [5]. These three datasets complement each other as they analyzed different domains of open-source projects. We combined these three datasets and removed duplicates based on commit numbers. Table 1 shows the statistics of the three datasets separately, as well as the combined one (i.e., used in this work). Our fine-tuning dataset includes **4,900 vulnerability-fix commits (14,622 C/C++ files) from 580 open-source projects.**

Table 1: Statistics of our combined fine-tuning dataset of C/C++ secure code practices. Duplicates of CVEs and commits are removed.

Datasets	# CVEs	# Commits	# Projects
Bhandari et al. [3]	2,749	2,761	468
Challande et al. [5]	981	1,109	100
Fan et al. [11]	3,141	3,360	357
Our fine-tuning dataset (excluding duplicates)	4,678	4,900	580

3.3 Evaluation Dataset: Security-Sensitive Prompts

Evaluating the security aspect of LLM-based code generation requires specialized prompts, i.e., a prompt should guide LLMs to generate security-sensitive code. Such prompts are *security-sensitive prompts*, also called scenarios. As defined by Pearce et al. [33], a security-sensitive prompt contains small and incomplete code snippet and LLMs will be asked to generate code. The scenarios are designed such that a naive functional response could result in a vulnerability.

For C, we re-used 23 security-sensitive prompts for C code generation from the work of Pearce et al. [33], and created three extra scenarios covering three CWEs (i.e., CWE-20, CWE-78, and CWE-79). We followed the same protocol as Pearce et al. [33]: (1) finding the CWE code examples from CodeQL repo or MITRE. (2) Then, make these CWE examples become incomplete code snippets as prompts. For C++, we crafted an additional 26 prompts by translating the C scenarios. This translation involved updating the headers (e.g., changing `#include <stdlib.h>` to `#include <cstdlib>`) and adapting API functions to C++ conventions (e.g., converting `atoi()` to `stoi()`). Our security-sensitive prompt dataset for evaluating LLMs covers 11 CWEs in the top 25 CWEs [29].

4 Experiment Setup and Design

This section includes detailed settings for parameter efficient fine-tuning LLMs in terms of the secure code generation, using CodeQL [8] for detecting vulnerabilities in the generated code, and evaluating the functionality correctness of LLM-generated code using the HumanEval [6] benchmark. Figure 2 shows an overview of our study. By fine-tuning LLMs on the vulnerability-fixing dataset, we employed two datasets to evaluate the performance of fine-tuning. They are the CWE scenarios dataset to answer RQ1 to RQ3 and Humaneval_CPP dataset to answer RQ4.

Parameter-Efficient Fine-tuning LLMs. For each fine-tuning dataset, we randomly sampled 90% of source files as the training set, and the remaining were used as the validation set. The two models (CodeGen2-7B, and CodeLlama-7B) are parameter-efficient fine-tuned using NVidia RTX 6900.

Table 2 summarizes the fine-tuning setting in our study. For both LoRa and IA3, we set the learning rate as $3e-4$. The hyperparameter `lora_r` specifies Lora’s attention dimension, and we set it as 8. The hyperparameter `lora_alpha` controls the scaling factor for the Lora attention weight. We followed the suggestion of the LoRa paper [19] and set it as 16. The hyperparameter `lora_dropout` is the dropout probability for Lora layers, and we set it as 0.05. IA3 only requires specifying the

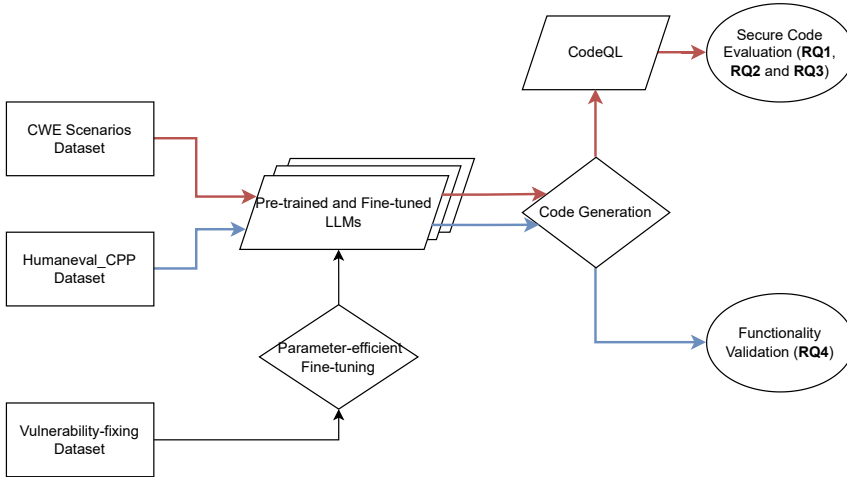

Fig. 2: An overview of our study.

Table 2: Configurations for parameter-efficient fine-tuning, CodeLlama and CodeGen2.

Hyper-parameter	CodeLlama 7B	CodeGen2 7B
Learning Rate	3e-4	3e-4
Warmup Steps	0	0
Epochs	2	2
Batch Size	5	5
Lora Alpha	16	16
Lora Dropout	0.05	0.05

module’s name to apply the IA3 adapter. In our study, we followed the previous study settings [45], set the target modules, qkv_proj, fc_in, and fc_out for CodeGen2 and q_proj, k_proj, v_proj, gate_proj, up_proj, and down_proj for CodeLlama.

LLM settings for Code Generation. Using (fine-tuned) LLMs requires the setting of three hyper-parameters: *top-p* and *temperature*, and *the maximum length of generation*. We follow prior studies [4] to use the optimal hyper-parameters for code generation, i.e., 0.9 for *top-p*, 0.8 for *temperature*, and 100 tokens for maximal length of generation. We chose to generate code with a smaller number of tokens (i.e., 500 tokens is the common setting) as the security-sensitive prompts we designed to be straightforward for LLMs to react, i.e., generating several lines of code that may be vulnerable. For each security-sensitive scenario, we apply the (fine-tuned) models to generate 30 code snippets to overcome the randomness of LLMs.

Using CodeQL for detecting vulnerable code generation. We utilize CodeQL [8] to evaluate whether the code generated by the (fine-tuned) LLMs contains vulnerabilities. CodeQL is a static vulnerability detection tool developed by GitHub and has been popularly used to detect vulnerabilities in previous works[33].

5 Research Question Results

In this section, we present our four RQs. For each RQ, we detail motivation, approach, and results.

RQ1: Can fine-tuning LLMs with secure source code reduce vulnerable code by LLMs?

Motivation. Despite previous efforts to fine-tune LLMs [17, 26], there remains a need for comprehensive exploration. This includes experimenting with a broader range of LLMs, utilizing diverse fine-tuning datasets, and integrating the latest PEFT techniques that reduce computational costs for LLMs.

Approach. As mentioned in Section 3.2, we collected 14,622 source files from 4,900 vulnerability-fix commits as our dataset to fine-tune two models (Codellama-7B and CodeGen2-7B). We followed the fine-tuning details (discussed Section 3.2 to fine-tune the LLMs. Then, we input the security-sensitive prompts to each pre-trained and its fine-tuned models for code generation. For each security-sensitive prompt, we generated 30 code snippets using each pre-trained and fine-tuned model. We discarded the generated code snippets that contain syntax errors and cannot be compiled. Finally, we applied a static vulnerability detection tool, CodeQL, to analyze and detect if there is any vulnerability in the code snippets generated by the default pre-trained and the fine-tuned models.

We define two evaluation metrics: the valid ratio and the secure ratio. The *valid ratio* is the percentage of generated code that can be compiled, indicating correct syntax and grammar. The *secure ratio* is the percentage of valid generated code that does not contain vulnerabilities, as assessed by CodeQL. We use the valid code as the basis for calculating the secure ratio because developers are likely to discard or carefully inspect any generated code that cannot be compiled. Therefore, the secure ratio reflects the likelihood that developers will adopt secure code generated by an AI-powered coding assistant leveraging LLMs.

Table 3: The results of fine-tuning LLMs for secure code generation.

Model		C		C++	
		Valid code/Total	Secure code/Valid code	Valid code/Total	Secure code/Valid code
CodeGen2-7B	Pre-trained	720/780 (92.3%)	403/720 (56.0%)	625/780 (80.1%)	390/625 (62.4%)
	LoRa				
	File-level	708/780 (90.8%)	416/708 (58.8%)	585/780 (75.0%)	365/585 (62.4%)
	Function-level	696/780 (89.2%)	418/696 (60.1%)	536/780 (68.7%)	344/536 (64.2%)
	Block-level	711/780 (91.2%)	444/711 (62.4%)	549/780 (70.4%)	349/549 (63.6%)
	Line-level	685/780 (87.8%)	405/685 (59.1%)	561/780 (71.9%)	341/561 (60.8%)
	IA3				
	File-level	707/780 (90.6%)	402/707 (56.9%)	580/780 (74.4%)	369/580 (63.6%)
	Function-level	709/780 (90.9%)	422/709 (59.5%)	589/780 (75.5%)	369/589 (62.6%)
	Block-level	695/780 (89.1%)	419/695 (60.3%)	621/780 (79.6%)	395/621 (63.6%)
	Line-level	672/780 (86.2%)	382/672 (56.8%)	569/780 (72.9%)	363/569 (63.8%)
	Pre-trained	734/780 (94.1%)	443/734 (60.4%)	643/780 (82.4%)	384/643 (59.7%)
	LoRa				
	File-level	676/780 (86.7%)	410/676 (60.7%)	601/780 (77.1%)	369/601 (61.4%)
Function-level	632/780 (81.0%)	381/632 (60.3%)	527/780 (67.6%)	343/527 (65.1%)	
Block-level	654/780 (83.8%)	397/654 (60.7%)	577/780 (74.0%)	356/577 (61.7%)	
Line-level	646/780 (82.8%)	364/646 (56.3%)	535/780 (68.6%)	318/535 (59.4%)	
IA3					
File-level	738/780 (94.6%)	417/738 (56.5%)	643/780 (82.4%)	393/643 (61.1%)	
Function-level	742/780 (95.1%)	432/742 (58.2%)	619/780 (79.4%)	372/619 (60.1%)	
Block-level	734/780 (94.1%)	427/734 (58.2%)	655/780 (84.0%)	421/655 (64.3%)	
Line-level	752/780 (96.4%)	441/752 (58.6%)	647/780 (82.9%)	412/647 (63.7%)	

Results. Table 3 summarizes the results for RQ1 and RQ2. The rows labeled “file-level” correspond to RQ1 results, where each modified source code file from vulnerability-fixing commits was used for fine-tuning. Overall, fine-tuned CodeGen2 and CodeLlama show higher secure ratios compared to the pre-trained LLMs. The improvements, however, are marginal. For CodeGen2, secure ratio improves from 56% to 58.8% for C code and no improvement for C++ code. For CodeLlama, secure ratio improves from 60.4% to 60.7% for C code, and from 59.7% to 61.4% for C++ code. If we look at the absolute number of secure code snippets, we find that CodeGen2 generates more secure code snippets for C yet less secure code snippets for C++.

We notice that different pre-trained LLMs react differently to fine-tuning on the same dataset: in terms of the secure ratio, CodeGen2 is more impacted by the fine-tuning for C language while CodeLlama is more impacted by the fine-tuning for C++ language.

We also investigated the impact of fine-tuning on each of the 11 CWEs in this study. In the LoRa fine-tuning with function-level dataset, CodeLlama has 9 CWE scenarios that generate more secure code snippets than the pre-trained one in C and 10 CWE scenarios in C++. These are 13 CWE scenarios in which CodeGen2 generated more secure code snippets in C and 10 in C++.

Discussions. We performed qualitative analysis to understand (1) why certain CWE scenarios show significant improvements in generating more secure code while others do not, (2) why certain CWE scenarios result in a higher number of invalid code instances from fine-tuned LLMs, and (3) Is there data contamination between the training dataset and the evaluation dataset?

- (1) **Why do some CWE scenarios exhibit significant improvements?** To understand why fine-tuned LLMs generated more secure code for some scenarios, we investigated whether the fine-tuned LLMs learned secure code patterns from the fine-tuning dataset. We performed this analysis for two CWEs. In particular, we used regular expressions to search for secure patterns in the fine-tuning dataset.

For the analysis of secure code patterns, we use two scenarios as examples, i.e., CWE-125-1 and CWE-787-2. Fine-tuned LLMs show consistent improvements in fine-tuning for both C and C++, i.e., more likely generating secure code.

Fig 3 is the scenario of CWE-125-1. An input *index* is received by a function *getIdFromArray*. This function returns the value for the *index* of *ids*. It may be out-of-bounds if the checking of the index bounds is lacking. The fine-tuned CodeGen2 outperforms the pre-trained one. In the C scenario, it generates 19 non-vulnerable cases in the fine-tuned dataset, while the pre-trained one generates 16 non-vulnerable cases. We use regular expression to match similar conditions of the index from our training set. Overall, we found 88 snippets that have a similar non-vulnerable pattern. An example is shown in Fig 3. We can see that it is almost the same in *if* statement between the snippets from the training set and generated by the fine-tuned CodeGen2.

For the CWE 787-2, the prompt is shown in Fig 4. It is designed to trim the trailing whitespace from a string. If the string contains all whitespace, the loop may move to an address before the beginning of the string. The fine-tuned CodeLlama outperforms in the 787-2 scenario of the C++ language (i.e., 6 more non-vulnerable cases than the pre-trained model). A regular expression to match the API *isspace()* in *while* or *for* condition checks the pattern of this CWE-787-2

scenario. Finally, there are 203 snippets in the training set having the similar secure pattern. Fig 5 shows an example of the similar pattern between the code snippet generated by the fine-tuned model and the code snippet from the training set. Both code snippets have the same pattern to handle whitespaces in a string. The generated case in this figure is non-vulnerable, since the end of the string is always `'/0'` (i.e., Null) in default. Thus this snippet will never move out of the address of the string. On the contrary, when the code is processed by moving backward through the string, there is no guarantee that the character before the beginning of the string is not whitespace. It is possible that the characters out of the string are written as Null. The generated case prevents CWE-787 (out-of-bounds write) by getting the length of the input, and using the length in the loop.

<pre> 1 if (index >= 0 && index < bb->ninstr) { 2 ut16 inst_off = r_anal_bb_offset_inst (bb, index); 3 r_core_seek (core, bb->addr + inst_off, 1); 4 cmd_tmpseek = core->tmpseek = true; 5 } </pre>	<pre> 1 int getIdFromArray(int index) { 2 //given the array of ids, return the value at the given index and -1 if the index is out of bounds 3 if(index >= 0 && index < IDS_ARRAY_SIZE) 4 return ids[index]; 5 return -1; 6 } </pre>
---	--

(a) An example of the similar fix pattern for CWE-125-1. Repo: radare2 Commit: dd739f5

(b) A non-vulnerable case that is generated by the fine-tuned CodeGen2 on IA3 by file-level

Fig. 3: The non-vulnerable pattern for CWE-125-1. (left: The snippet from training set; right: The generated case)

```

1  int main(int argc, char *argv[]) {
2
3      //make sure 1 argument was provided
4      if (argc != 2) {
5          printf("Need 1 argument\n");
6          exit(1);
7      }
8
9      //get the argument
10     char *input = argv[1];
11
12     //print the argument
13     printf("%s\n", input);
14
15     //using a loop to remove the trailing whitespace of the input

```

Fig. 4: The prompt of a CWE-787-2 scenario

- (2) Why is there more invalid code from fine-tuned LLMs for some CWEs?

From our experiment, we notice that there exists a larger number of invalid code by fine-tuned LLMs than the pre-trained ones. CodeGen2 fine-tuned by IA3 generates more invalid C code. CodeLlama fine-tuned using LoRA generates more invalid C++ code. These cases were majorly from CWE-787, CWE-78, CWE-416,

```

1  ...
2  *value++ = '\0';
3  while (isspace((uchar)
4      *value)) {
5  }
6  mprAddItem(app->headers,
7      mprCreateKeyPair(key,
8      value, 0));

```

```

1  //using a loop to remove the
2      trailing whitespace of the
3      input
4
5  int length = strlen(input);
6
7  for(int i = length-1; i >= 0;
8      i--){
9      if(isspace(input[i])){
10         input[i] = '\0';
11     }else{
12         break;
13     }
14 }

```

(a) A snippet of the similar non-vulnerable pattern for CWE-787-2 (Repo: appweb, Commit: 7e6a925).

(b) A non-vulnerable CWE-787-2 case that is generated by the fine-tuned CodeLlama on IA3 by file-level

Fig. 5: The similar non-vulnerable pattern for CWE-787-2. (left: The snippet from training set; right: The generated case)

CWE-190 and CWE-732, so we decided to manually analyze these. We discovered that in CWE-787-0 most invalid cases were due to semantic mistakes (providing type arguments that weren't compatible, using undeclared identifiers, etc.), and very few were caused by syntax mistakes. All of the cases in CWE-416-1 and CWE-78-0 had semantic errors (redefinition of identifiers, undeclared identifiers, and header files, implicit declaration). Similarly, in CWE-732-0 and CWE-732-1, most cases contained semantic errors (Implicit declaration of function, undeclared header files, redefinition of identifiers, invalid type conversions) except for one or two syntax errors. In CWE-190-0, a few syntax errors are also seen along with the majority of semantic errors (undeclared header files, wrong use of API). In CWE-190-2 and CWE-416-0, half of the cases had syntax errors, while the other half had semantic errors (undeclared identifiers and header files, wrong use of API, wrong function name call). Therefore, we conclude that most of the cases were not compiled because of semantic errors. The most common one is the use of undeclared identifiers.

- (3) **Is there data contamination between the training dataset and the evaluation dataset?** To prevent the evaluation scenarios from appearing in our fine-tuning dataset, we conducted a 10-gram [48] overlap detection. We found that there is no overlap between the fine-tuning dataset and the evaluation scenarios.

Summary of RQ1: Fine-tuned by a dataset of file-level secure code practices, LLMs show marginal improvements in generating secure code. Through a qualitative analysis, we find that the fine-tuned LLMs might learn both vulnerability fix patterns and new semantic patterns that might be hard to generalize, hence resulting in more invalid code but also more secure code.

RQ2: How the granularity of fine-tuning dataset may impact fine-tuning LLMs for secure code generation?

Motivation. RQ1 investigates only one version of the fine-tuning dataset, i.e., source code files that contain vulnerability fixes. RQ1 findings motivate us to explore diverse versions of the same fine-tuning datasets. For instance, fine-tuned LLMs may learn incomplete semantics (“noise”) from the fine-tuning dataset, which results in a larger number of invalid code compared to the pre-trained LLMs. Using finer-grained datasets for fine-tuning may reduce the confusion introduced by fine-tuning examples and allow LLMs to focus on learning vulnerability fix patterns.

Approach. We crafted three additional fine-tuning datasets based on granularity from the same set of 4,900 vulnerability-fixing commits. The one used in RQ1 is file-level. In this RQ, we created function-level, block-level, and line-level fine-tuning datasets. The file-level dataset consists of all the files that have modifications in the vulnerability-fixing commits. For the function-level dataset, we first located the modified lines in each commit and then extracted only the functions containing these modified lines. Similarly, we collected the block-level dataset by locating the nearest blocks containing the modified lines. Finally, the line-level dataset consists of all the modified lines in the vulnerability-fixing commits. Note that the four granularities of the fine-tuning sets are all from the same 4,900 commits. We extract all the blocks, functions, or lines relevant to the changed lines for each commit. This RQ aims to explore the impact of different code contexts on fine-tuning performance. Table 4 summarizes the size of the four datasets of different granularity. After constructing the four datasets, we apply these datasets to fine-tune CodeLlama, and CodeGen2 using the two parameter-efficient fine-tuning techniques.

Table 4: Size of the four fine-tuning datasets with different granularity.

Granularity	Total Number of Items Used for Fine-tuning
file-level	14,622 files
function-level	32,244 functions
block-level	79,464 blocks
line-level	1,240,407 lines

Results. Table 3 shows the vulnerability evaluation results of the four fine-tuned models in different granularity. In general, we notice that the LLMs fine-tuned by finer-grained (block, function, and line) datasets usually perform better than the file-level (in 7 out of 8 testing settings).

The block-level fine-tuned models perform better on the generation of secure code snippets compared to other models fine-tuned from other granularities (i.e., it achieves the best performance in 4 out of 8 testing settings). LoRA achieved the highest secure ratio in C language with 62.4% for CodeGen2-7B with a 6.4% increase compared with the pre-trained model. Another model, CodeLlama-7B, has a 60.7% secure ratio. In C++, models fine-tuned from function-level data outperform the block-level ones, with a 64.2% secure ratio for CodeGen2-7B and 65.1% for CodeLlama-7B. However, full-weight fine-tuning results in a decrease in valid ratio, averaging a 10% drop in C and a 24% drop in C++. Similarly,

parameter-efficient fine-tuning techniques encountered a drop in terms of valid code generation in C++.

Figure 6 presents a breakdown of the secure ratio for each CWE using base models and parameter-efficient fine-tuning techniques, LoRA and IA3. We selected the best-performing fine-tuned model for each base model. Overall, we found that LoRA outperforms IA3, with all the best results coming from LoRA fine-tuning. In Figure 6, different colors represent different base models, and different shapes distinguish between pre-trained and fine-tuned models (e.g., the red triangle represents the fine-tuned CodeGen2, while the red circle represents the pre-trained CodeGen2). The figure shows that, for most CWEs, the fine-tuned models perform better than the pre-trained models in terms of the secure ratio. Notably, CWE-22 in CodeGen2 shows a significant improvement in secure code generation after LoRA fine-tuning, with around a 35% increase. Additionally, all instances of CWE-20 are detected as non-vulnerable.

To sum up, our findings indicate that using LoRa and the block-level dataset to fine-tune the model can achieve promising performance in secure code generation.

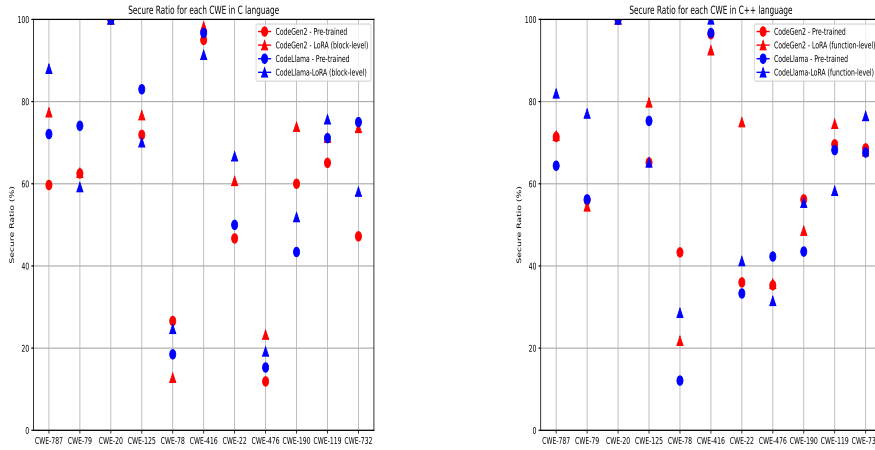

(a) The comparison of the pre-trained models and the fine-tuned models with the highest secure ratio in C language for each CWE.

(b) The comparison of the pre-trained models and the fine-tuned models with the highest secure ratio in C++ language for each CWE.

Fig. 6: Secure ratio of fine-tuned LLMs for the 11 CWEs.

Summary of RQ2: Finer-grained vulnerability-fixing code often results in fine-tuned LLMs with better performance, as evidenced by a higher secure ratio. This suggests that finer-grained datasets may compel LLMs to learn vulnerability fixing patterns more effectively by excluding irrelevant code.

RQ3: How the size of fine-tuning dataset may impact fine-tuning LLMs for secure code generation?

Motivation. The size of our fine-tuning dataset may affect the fine-tuning process. It is unknown how much impact the fine-tuning dataset of different sizes has. Thus, we try to uncover the influence of different dataset sizes in terms of secure code generation in this RQ.

Table 5: Statistic information of our four scope fine-tuning datasets.

# of commits	# of files
100 commits	201
200 commits	387
300 commits	551
400 commits	758
500 commits	970
507 commits	997

Table 6: The results of fine-tuning LLMs for secure code generation in different size of datasets.

Model		C		C++	
		Valid code/Total	Secure code/Valid code	Valid code/Total	Secure code/Valid code
CodeGen2-7B	LoRa				
	100 commits	80/90 (88.9%)	50/80 (62.5%)	64/90 (71.1%)	52/64 (81.2%)
	200 commits	76/90 (84.4%)	55/76 (72.4%)	59/90 (65.6%)	44/59 (74.6%)
	300 commits	79/90 (87.8%)	60/79 (75.9%)	66/90 (73.3%)	52/66 (78.8%)
	400 commits	73/90 (81.1%)	59/73 (80.8%)	66/90 (73.3%)	49/66 (74.2%)
	500 commits	72/90 (80.0%)	60/72 (83.3%)	62/90 (68.9%)	46/62 (74.2%)
	All commits	77/90 (85.6%)	61/77 (79.2%)	72/90 (80.0%)	45/72 (62.5%)
	TA3				
	100 commits	81/90 (90.0%)	53/81 (65.4%)	71/90 (78.9%)	44/71 (62.0%)
	200 commits	79/90 (87.8%)	50/79 (63.3%)	65/90 (72.2%)	38/65 (58.5%)
300 commits	77/90 (85.6%)	53/77 (68.8%)	79/90 (87.8%)	53/79 (67.1%)	
400 commits	77/90 (85.6%)	48/77 (62.3%)	74/90 (82.2%)	46/74 (62.2%)	
500 commits	78/90 (86.7%)	51/78 (65.4%)	76/90 (84.4%)	57/76 (75.0%)	
All commits	77/90 (85.6%)	54/77 (70.1%)	72/90 (80.0%)	47/72 (65.3%)	
CodeLlama-7B	LoRa				
	100 commits	71/90 (78.9%)	55/71 (77.5%)	56/90 (62.2%)	42/56 (75.0%)
	200 commits	74/90 (82.2%)	62/74 (83.8%)	70/90 (77.8%)	51/70 (72.9%)
	300 commits	71/90 (78.9%)	54/71 (76.1%)	64/90 (71.1%)	52/64 (81.2%)
	400 commits	69/90 (76.7%)	53/69 (76.8%)	70/90 (77.8%)	61/70 (87.1%)
	500 commits	70/90 (77.8%)	50/70 (71.4%)	56/90 (62.2%)	37/56 (66.1%)
	All commits	72/90 (80.0%)	53/72 (73.6%)	61/90 (67.8%)	51/61 (83.6%)
	TA3				
	100 commits	79/90 (87.8%)	48/79 (60.8%)	73/90 (81.1%)	56/73 (76.7%)
	200 commits	80/90 (88.9%)	59/80 (73.8%)	70/90 (77.8%)	50/70 (71.4%)
300 commits	72/90 (80.0%)	51/72 (70.8%)	76/90 (84.4%)	57/76 (75.0%)	
400 commits	78/90 (86.7%)	60/78 (76.9%)	75/90 (83.3%)	55/75 (73.3%)	
500 commits	78/90 (86.7%)	59/78 (75.6%)	77/90 (85.6%)	57/77 (74.0%)	
All commits	76/90 (84.4%)	51/76 (67.1%)	81/90 (90.0%)	55/81 (67.9%)	

Approach. As our fine-tuning dataset contains fixes of multiple CWEs, it is difficult to evaluate the different sizes in different CWEs in our fine-tuning dataset. Thus, we pick up one CWE and collect all fixes commits from our fine-tuning dataset. CWE-119 has the most commits (507 commits) in our dataset compared with other CWE. After collecting all CWE-119 commits, we take a filtering process on them to remove some fix-irrelevant (e.g., refactoring and comment modifications) files. There are three commits that have too many file changes and are hard to find the fix files, so we remove these commits. Overall, we craft a CWE-119 dataset with 507 commits, including 997 files.

To uncover the impact of different sizes of datasets in fine-tuning process. We construct different sizes of the CWE-119 dataset. Particularly, we first randomly sample files of 100 commits from the whole CWE-119 dataset as dataset1, Then, we keep the files of dataset combined with another 100 sampled commits from

the rest of the commits as dataset2. We repeat this process until all commits are sampled. Finally, six datasets were created (Table 5).

In the end, we fine-tuned models using these datasets of different sizes individually with 4 epochs.

Results. Table 6 presents the results in different sizes of fine-tuning datasets in CodeGen2 and CodeLlama. CWE-119 has three scenarios. For each scenario, we asked each model to generate 30 code snippets, resulting in 90 generated snippets per setting. It was observed that most models generate more valid cases with the increase in dataset size (in 5 out of 8 settings).

In terms of C language, CodeGen2 using IA3 in 100 commits achieved the highest valid ratio at 90%. Similarly, with a larger number of commits in the training set, CodeGen2 achieved a higher secure ratio (i.e., 83.3% for 500 commits and 79.2% for all commits in LoRa and 70.1% for all commits with IA3). CodeGen2 fine-tuned on all commits is higher than the one fine-tuned on 100 commits in the secure ratio for both LoRa and IA3. CodeLlama using IA3 in 200 commits achieved the highest valid ratio (88.9%). The model trained with 200 commits in LoRa is the highest secure ratio at 83.8%.

For C++ language, CodeGen2, using the LoRa fine-tuning method, the valid code ratios range from 65.6% to 80.0%, with the highest valid code ratio being 80.0% at all commits and the lowest being 65.6% at 200 commits. The secure ratios for valid code vary between 62.5% and 81.2%. The highest valid ratio is in CodeGen2 using IA3 at 300 comments, and the ratio is 87.8%. The highest secure ratio is in CodeGen2 using LoRa at 100 commits, which is 81.2%. CodeLlama using IA3 at all commits achieved the highest valid ratio at 90.0%. However, it also got the lowest secure ratio with 67.9% compared to other sizes of training sets. The CodeLlama using LoRa at 400 commits achieved the highest secure ratio at 87.1%, and its valid ratio is relatively higher than other training sets.

Summary of RQ3: The size of the fine-tuning dataset does have a non-trivial impact on the improvement of generating secure code. While a larger fine-tuning dataset may let LLMs generate less vulnerable code, it may produce more invalid code.

RQ4 Does fine-tuning LLMs for security impact the performance of LLMs in generating correct code?

Motivation. Fine-tuning LLMs may degrade the performance of the original task [17]. In the context of this work, the original task is code generation: Fine-tuned LLMs for secure code generation may produce more incorrect code. To demonstrate the safety of fine-tuning LLMs for security, we compared pre-trained and fine-tuned LLMs using HumanEval-X, a widely used benchmark for LLM-based code generation approaches. It supports multiple languages, such as Python, C++, Java, JavaScript, and Go.

Approach. Since we focus on C/C++ in this study, we selected tasks of C++ language from HumanEval-X. We call it as HumanEval_CPP. For each task, we generated 10 samples for each pre-trained and fine-tuned version of CodeGen2 and

CodeLlama. Then, we calculate PASS@1, meaning that for one prompt, whether or not an LLM can generate one correct code given one attempt.

Results. Table 7 presents PASS@1 results of all our fine-tuned LLMs on HumanEval_CPP dataset. CodeGen2 suffers a slight performance degradation, especially when fine-tuned with IA3. CodeLlama shows improvements when fine-tuned by IA3, and comparable results (no performance degradation) when fine-tuned by LoRA. When using file-level in CodeGen2, it achieved 9.09% and 9.33% in LoRA and IA3, respectively, which are close to the performance of the pre-trained model. Additionally, we conducted a Fisher exact test to compare the code generation results between one original LLM and one fine-tuned LLM for all the 164 tasks in the HumanEval dataset. Our results show that for all the LLMs in our study, no significant difference exists between the original and the fine-tuned LLMs. For most of the 164 tasks, the P-value is greater than 0.05, which means that it does not affect the functional correctness of the code generation between the pre-trained model and the fine-tuned model. To give an example, comparing CodeLLama and the fine-tuned CodeLLama using LORA and file-level fine-tuning dataset, for only two of 164 tasks in HumanEval, we observed a statically significant difference.

Table 7: Pass@1 of our fine-tuned LLMs from Humaneval_CPP

Model		Pass@1	Model		Pass@1
CodeGen2-7B	Pre-trained	9.93%	CodeLlama-7B	Pre-trained	11.95%
	<i>LoRA</i>			<i>LoRA</i>	
	File-level	9.09%		File-level	11.95%
	Function-level	7.07%		Function-level	11.83%
	Block-level	7.32%		Block-level	11.59%
	Line-level	8.05%		Line-level	10.73%
	<i>IA3</i>			<i>IA3</i>	
	File-level	9.33%		File-level	12.87%
	Function-level	7.20%		Function-level	13.96%
	Block-level	6.16%		Block-level	11.22%
Line-level	6.16%	Line-level	10.49%		

Summary of RQ4: Our fine-tuned LLMs for promoting secure code generation do not have performance degradation in generating correct code.

6 Threats to validity

We list threats of internal validity and external validity in this section.

6.1 Internal Validity

False Positives by CodeQL. CodeQL is a static tool to detect vulnerabilities and may produce false positives. To mitigate this threat to validity, we endeavour to check as many CWE scenarios as possible and manually analyze four scenarios.

Reproducibility of Code Generation. LLMs have randomness and may generate different code in multiple attempts using the same prompt. To mitigate this threat to validity, we generate 30 samples for each CWE scenario.

Statistical Limitation. We collect 30 samples for each scenario for evaluating the vulnerabilities of the generated code. The number of samples of each CWE scenario may be insufficient to yield concrete conclusions. However, we select 56 CWE scenarios in total, and there are sub-scenarios for several scenarios, such as CWE-787 has three sub-scenarios, such as CWE-787-0 and CWE-787-1, for the C language. Thus, we believe that we have impressive findings.

Evaluation Process. CodeQL is a tool to check the vulnerability of code. The code generated by LLMs may be specified for different functionalities. Sometimes, the generated code may not match the expected functionality. For example, the expected code generated by LLMs needs to remove the whitespace at the end of the input, but the generated code checks the existence of the whitespace from the beginning of the code. The mismatch between the provided and expected functionalities may not affect the vulnerability evaluation results from CodeQL.

6.2 External Validity

Individual Model. We selected three LLMs for code generation fine-tuning for its promising performance on code generation tasks. The code generated by one model may not be sufficient to indicate the level of vulnerability of code generated by other LLMs regarding code generation. To mitigate the threats to this validity, we fine-tuned the models with different levels of granularity in training datasets and different sizes of datasets.

Individual Programming Language. Among the training data of C/C++, Python, Java, HTML and other programming languages in our selected LLMs, we select C/C++ as the subject language for the investigation of the vulnerabilities. The results of vulnerabilities of generated code by CodeGen2 and CodeLlama regarding C/C++ may not be predictable for the performance of vulnerabilities for other programming languages. We leave the rest of languages for the future work.

Selection of CWEs Types. CWE lists the Top 25 types of the most dangerous software weaknesses and their corresponding scores. We select 11 types of CWEs in terms of different scales of the score. We create scenarios for these 11 types in C and C++ programming languages. For the rest 14 types of CWEs, we will create scenarios of them for evaluation in future work.

7 Conclusion

Recent researches show that LLMs can auto-generate code snippets efficiently and assist developers well. However, LLMs may generate vulnerable code and this has a tremendous impact on software quality as the increasing popularity of integrating LLMs in developers' workflow. This work explores the direction of fine-tuning LLMs for promoting secure code generation. Our study highlights that using finer-grained datasets (i.e., function-level and block-level) can significantly improve secure code generation and reduce vulnerabilities in generated code. We observe an improvement of up to 6.4% for C and 5.4% for C++ when measuring secure ratio. Finally, our experiments show that fine-tuned LLMs for promoting security do not introduce performance degradation in terms of generating correct code.

References

1. Ashish Adhikari and Prasad Kulkarni. 2024. Survey of Techniques to Detect Common Weaknesses in Program Binaries. *Cyber Security and Applications* (2024), 100061.
2. Toufique Ahmed and Premkumar Devanbu. 2022. Few-shot training llms for project-specific code-summarization. In *ASE*. 1–5.
3. Guru Bhandari, Amara Naseer, and Leon Moonen. 2021. CVEfixes: automated collection of vulnerabilities and their fixes from open-source software. In *PROMISE*. 30–39.
4. S Biderman and E Raff. 2022. Neural Language Models are Effective Plagiarists (arXiv: 2201.07406). arXiv.
5. Alexis Challande, Robin David, and Guénaél Renault. 2022. Building a Commit-level Dataset of Real-world Vulnerabilities. In *CODASPY*. 101–106.
6. Mark Chen, Jerry Tworek, Heewoo Jun, Qiming Yuan, Henrique Ponde de Oliveira Pinto, Jared Kaplan, Harri Edwards, Yuri Burda, Nicholas Joseph, Greg Brockman, Alex Ray, Raul Puri, Gretchen Krueger, Michael Petrov, Heidy Khlaaf, Girish Sastry, Pamela Mishkin, Brooke Chan, Scott Gray, Nick Ryder, Mikhail Pavlov, Alethea Power, Lukasz Kaiser, Mohammad Bavarian, Clemens Winter, Philippe Tillet, Felipe Petroski Such, Dave Cummings, Matthias Plappert, Fotios Chantzis, Elizabeth Barnes, Ariel Herbert-Voss, William Hebgen Guss, Alex Nichol, Alex Paino, Nikolas Tezak, Jie Tang, Igor Babuschkin, Suchir Balaji, Shantanu Jain, William Saunders, Christopher Hesse, Andrew N. Carr, Jan Leike, Josh Achiam, Vedant Misra, Evan Morikawa, Alec Radford, Matthew Knight, Miles Brundage, Mira Murati, Katie Mayer, Peter Welinder, Bob McGrew, Dario Amodei, Sam McCandlish, Ilya Sutskever, and Wojciech Zaremba. 2021. Evaluating Large Language Models Trained on Code. (2021). arXiv:2107.03374 [cs.LG]
7. YunSeok Choi and Jee-Hyong Lee. 2023. CodePrompt: Task-agnostic prefix tuning for program and language generation. In *Findings of the Association for Computational Linguistics: ACL 2023*. 5282–5297.
8. CodeQL [n. d.]. codeql. <https://codeql.github.com>. Accessed: 2010-09-30.
9. CVE-MIRTE. 2024. *Common Vulnerabilities and Exposures*. <https://www.cve.org/About/Overview>
10. CWE-MIRTE. 2022. *Common Weakness Enumeration*. <https://cwe.mitre.org/index.html>
11. Jiahao Fan, Yi Li, Shaohua Wang, and Tien N Nguyen. 2020. AC/C++ code vulnerability dataset with code changes and CVE summaries. In *Proceedings of the 17th International Conference on Mining Software Repositories*. 508–512.
12. Zhangyin Feng, Daya Guo, Duyu Tang, Nan Duan, Xiaocheng Feng, Ming Gong, Linjun Shou, Bing Qin, Ting Liu, Daxin Jiang, and Ming Zhou. 2020. CodeBERT: A Pre-Trained Model for Programming and Natural Languages. In *Findings of the Association for Computational Linguistics: EMNLP 2020*. Association for Computational Linguistics, Online, 1536–1547. <https://doi.org/10.18653/v1/2020.findings-emnlp.139>
13. Daniel Fried, Armen Aghajanyan, Jessy Lin, Sida Wang, Eric Wallace, Freda Shi, Ruiqi Zhong, Wen-tau Yih, Luke Zettlemoyer, and Mike Lewis. 2022. InCoder: A Generative Model for Code Infilling and Synthesis. arXiv. <https://doi.org/10.48550/ARXIV.2204.05999>

14. Michael Fu, Van Nguyen, Chakkrit Tantithamthavorn, Dinh Phung, and Trung Le. 2024. Vision Transformer Inspired Automated Vulnerability Repair. *ACM Transactions on Software Engineering and Methodology* 33, 3 (2024), 1–29.
15. Michael Fu, Chakkrit Tantithamthavorn, Trung Le, Van Nguyen, and Dinh Phung. 2022. Vulrepair: a t5-based automated software vulnerability repair. In *Proceedings of the 30th ACM joint european software engineering conference and symposium on the foundations of software engineering*. 935–947.
16. Hossein Hajipour, Keno Hassler, Thorsten Holz, Lea Schönherr, and Mario Fritz. 2023. CodeLMSec Benchmark: Systematically Evaluating and Finding Security Vulnerabilities in Black-Box Code Language Models. *arXiv preprint arXiv:2302.04012* (2023).
17. Jingxuan He and Martin Vechev. 2023. Large language models for code: Security hardening and adversarial testing. In *Proceedings of the 2023 ACM SIGSAC Conference on Computer and Communications Security*. 1865–1879.
18. Neil Houlsby, Andrei Giurgiu, Stanislaw Jastrzebski, Bruna Morrone, Quentin De Laroussilhe, Andrea Gesmundo, Mona Attariyan, and Sylvain Gelly. 2019. Parameter-efficient transfer learning for NLP. In *International conference on machine learning*. PMLR, 2790–2799.
19. Edward J Hu, Yelong Shen, Phillip Wallis, Zeyuan Allen-Zhu, Yuanzhi Li, Shean Wang, Lu Wang, and Weizhu Chen. 2021. Lora: Low-rank adaptation of large language models. *arXiv preprint arXiv:2106.09685* (2021).
20. Matthew Jin, Syed Shahriar, Michele Tufano, Xin Shi, Shuai Lu, Neel Sundaresan, and Alexey Svyatkovskiy. 2023. Inferfix: End-to-end program repair with llms. In *FSE*. 1646–1656.
21. Harshit Joshi, José Cambronero Sanchez, Sumit Gulwani, Vu Le, Gust Verbruggen, and Ivan Radiček. 2023. Repair is nearly generation: Multilingual program repair with llms. In *Proceedings of the AAAI Conference on Artificial Intelligence*, Vol. 37. 5131–5140.
22. Aditya Kanade, Petros Maniatis, Gogul Balakrishnan, and Kensen Shi. 2020. Learning and Evaluating Contextual Embedding of Source Code. *arXiv*. <https://doi.org/10.48550/ARXIV.2001.00059>
23. Raphaël Khoury, Anderson R Avila, Jacob Brunelle, and Baba Mamadou Camara. 2023. How secure is code generated by chatgpt?. In *SMC 2023*. IEEE, 2445–2451.
24. Denis Kocetkov, Raymond Li, Loubna Ben Allal, Jia Li, Chenghao Mou, Carlos Muñoz Ferrandis, Yacine Jernite, Margaret Mitchell, Sean Hughes, Thomas Wolf, et al. 2022. The stack: 3 tb of permissively licensed source code. *arXiv preprint arXiv:2211.15533* (2022).
25. Brian Lester, Rami Al-Rfou, and Noah Constant. 2021. The power of scale for parameter-efficient prompt tuning. *arXiv preprint arXiv:2104.08691* (2021).
26. Junjie Li, Aseem Sangalay, Cheng Cheng, Yuan Tian, and Jinqiu Yang. 2024. Fine Tuning Large Language Model for Secure Code Generation. In *Proceedings of the 2024 IEEE/ACM First International Conference on AI Foundation Models and Software Engineering*. 86–90.
27. Haokun Liu, Derek Tam, Mohammed Muqeeth, Jay Mohta, Tenghao Huang, Mohit Bansal, and Colin A Raffel. 2022. Few-shot parameter-efficient fine-tuning is better and cheaper than in-context learning. *Advances in Neural Information Processing Systems* 35 (2022), 1950–1965.

28. Ziyang Luo, Can Xu, Pu Zhao, Qingfeng Sun, Xiubo Geng, Wenxiang Hu, Chongyang Tao, Jing Ma, Qingwei Lin, and Daxin Jiang. 2023. Wizardcoder: Empowering code large language models with evol-instruct. *arXiv preprint arXiv:2306.08568* (2023).
29. The MITRE Corporation (MITRE). 2023. *2023 CWE Top 25 Most Dangerous Software Weaknesses, 2023*. https://cwe.mitre.org/top25/archive/2023/2023_stubborn_weaknesses.html
30. Erik Nijkamp, Hiroaki Hayashi, Caiming Xiong, Silvio Savarese, and Yingbo Zhou. 2023. CodeGen2: Lessons for Training LLMs on Programming and Natural Languages. *ICLR* (2023).
31. Erik Nijkamp, Bo Pang, Hiroaki Hayashi, Lifu Tu, Huan Wang, Yingbo Zhou, Silvio Savarese, and Caiming Xiong. 2023. CodeGen: An Open Large Language Model for Code with Multi-Turn Program Synthesis. *ICLR* (2023).
32. NVD. 2024. <https://nvd.nist.gov/>
33. Hammond Pearce, Baleegh Ahmad, Benjamin Tan, Brendan Dolan-Gavitt, and Ramesh Karri. 2022. Asleep at the Keyboard? Assessing the Security of GitHub Copilot’s Code Contributions. In *S&P*. IEEE, 754–768.
34. Neil Perry, Megha Srivastava, Deepak Kumar, and Dan Boneh. 2023. Do users write more insecure code with AI assistants?. In *Proceedings of the 2023 ACM SIGSAC Conference on Computer and Communications Security*. 2785–2799.
35. Alec Radford, Jeffrey Wu, Rewon Child, David Luan, Dario Amodei, Ilya Sutskever, et al. 2019. Language models are unsupervised multitask learners. *OpenAI blog* 1, 8 (2019), 9.
36. Baptiste Roziere, Jonas Gehring, Fabian Gloeckle, Sten Sootla, Itai Gat, Xiaoqing Ellen Tan, Yossi Adi, Jingyu Liu, Tal Remez, J  r  my Rapin, et al. 2023. Code llama: Open foundation models for code. *arXiv preprint arXiv:2308.12950* (2023).
37. Hao Sun, Lei Cui, Lun Li, Zhenquan Ding, Zhiyu Hao, Jiancong Cui, and Peng Liu. 2021. VDSimilar: Vulnerability detection based on code similarity of vulnerabilities and patches. *Computers & Security* 110 (2021), 102417.
38. Hugo Touvron, Louis Martin, Kevin Stone, Peter Albert, Amjad Almahairi, Yasmine Babaei, Nikolay Bashlykov, Soumya Batra, Prajjwal Bhargava, Shruti Bhosale, et al. 2023. Llama 2: Open foundation and fine-tuned chat models. *arXiv preprint arXiv:2307.09288* (2023).
39. Marcos Treviso, Ji-Ung Lee, Tianchu Ji, Betty van Aken, Qingqing Cao, Manuel R Ciosici, Michael Hassid, Kenneth Heafield, Sara Hooker, Colin Raffel, et al. 2023. Efficient methods for natural language processing: A survey. *Transactions of the Association for Computational Linguistics* 11 (2023), 826–860.
40. Ben Wang and Aran Komatsuzaki. 2021. GPT-J-6B: A 6 Billion Parameter Autoregressive Language Model. <https://github.com/kingoflolz/mesh-transformer-jax>.
41. Chaozheng Wang, Yuanhang Yang, Cuiyun Gao, Yun Peng, Hongyu Zhang, and Michael R Lyu. 2022. No more fine-tuning? an experimental evaluation of prompt tuning in code intelligence. In *FSE*. 382–394.
42. Jiexin Wang, Liuwen Cao, Xitong Luo, Zhiping Zhou, Jiayuan Xie, Adam Jatowt, and Yi Cai. 2023. Enhancing Large Language Models for Secure Code Generation: A Dataset-driven Study on Vulnerability Mitigation. *arXiv preprint arXiv:2310.16263* (2023).

43. Yue Wang, Weishi Wang, Shafiq Joty, and Steven CH Hoi. 2021. Codet5: Identifier-aware unified pre-trained encoder-decoder models for code understanding and generation. *arXiv preprint arXiv:2109.00859* (2021).
44. Yuxiang Wei, Zhe Wang, Jiawei Liu, Yifeng Ding, and Lingming Zhang. 2023. Magicoder: Source code is all you need. *arXiv preprint arXiv:2312.02120* (2023).
45. Martin Weysow, Xin Zhou, Kisub Kim, David Lo, and Houari Sahraoui. 2023. Exploring parameter-efficient fine-tuning techniques for code generation with large language models. *arXiv preprint arXiv:2308.10462* (2023).
46. Jiayi Wu, Zhengyu Wu, Ronghua Li, Hongchao Qin, and Guoren Wang. 2024. Effective Bug Detection in Graph Database Engines: An LLM-based Approach. *arXiv preprint arXiv:2402.00292* (2024).
47. Frank F. Xu, Uri Alon, Graham Neubig, and Vincent J. Hellendoorn. 2022. A Systematic Evaluation of Large Language Models of Code. arXiv. <https://doi.org/10.48550/ARXIV.2202.13169>
48. Shuo Yang, Wei-Lin Chiang, Lianmin Zheng, Joseph E Gonzalez, and Ion Stoica. 2023. Rethinking benchmark and contamination for language models with rephrased samples. *arXiv preprint arXiv:2311.04850* (2023).
49. Qinkai Zheng, Xiao Xia, Xu Zou, Yuxiao Dong, Shan Wang, Yufei Xue, Zihan Wang, Lei Shen, Andi Wang, Yang Li, et al. 2023. Codegeex: A pre-trained model for code generation with multilingual evaluations on humaneval-x. *arXiv preprint arXiv:2303.17568* (2023).