

# Survey for Landing Generative AI in Social and E-commerce Recsys – the Industry Perspectives

Da Xu  
LinkedIn  
Sunnyvale, California, USA  
dxu2@linkedin.com

Danqing Zhang  
Amazon  
Palo Alto, California, USA  
danqinz@amazon.com

Guangyu Yang  
Tiktok  
Santa Clara, California, USA  
guangyu.yang@tiktok.com

Bo Yang  
Amazon  
Palo Alto, California, USA  
byyng@amazon.com

Shuyuan Xu  
Rutgers University  
New Brunswick, New Jersey, USA  
shuyuan.xu@rutgers.edu

Lingling Zheng  
Microsoft  
Redmond, Washington, USA  
linzheng@microsoft.com

Cindy Liang  
LinkedIn  
Sunnyvale, California, USA  
cliang@linkedin.com

## ABSTRACT

Recently, generative AI (GAI), with their emerging capabilities, have presented unique opportunities for augmenting and revolutionizing industrial recommender systems (Recsys). Despite growing research efforts at the intersection of these fields, the integration of GAI into industrial Recsys remains in its infancy, largely due to the intricate nature of modern industrial Recsys infrastructure, operations, and product sophistication. Drawing upon our experiences in successfully integrating GAI into several major social and e-commerce platforms, this survey aims to comprehensively examine the underlying system and AI foundations, solution frameworks, connections to key research advancements, as well as summarize the practical insights and challenges encountered in the endeavor to integrate GAI into industrial Recsys. As pioneering work in this domain<sup>1</sup>, we hope outline the representative developments of relevant fields, shed lights on practical GAI adoptions in the industry, and motivate future research.

## KEYWORDS

Generative AI, Recommender System, Large Language Model, LLMs, Retrieval-augmented Generation, Autonomous Agent, Evaluation, Human-AI Alignment, Trust and Safety, Responsible AI

## 1 INTRODUCTION

**Motivation** – the last two years have been a thrilling journey for generative AI (GAI) and its emerging capabilities, revolutionizing and reshaping the technology landscape across major domains [8, 146]. Recommendation systems (Recsys) have not been left behind, as the field experiences a surge of innovative ideas and research works that leverage GAI to augment or replace existing system components and layers [35, 84, 138]. Nonetheless, landing these innovations in the real world systems, especially those for social and e-commerce recommendations [118, 132], poses significant challenges. In particular, industrial Recsys are powered by

sophisticated and compound AI systems that encompass not only AI models but also infrastructure, operational processes, as well as business and product considerations. Effectively integrating new technologies requires a holistic approach in practice.

Our work emerges at a crucial juncture to provide an *up-to-date*, *application-centric*, and *interdisciplinary* survey tailored for the industry and Recsys community.

### 1.1 Outline

The first part of the survey aims to offer a concise overview of existing industrial recsys and several key deficiencies, and the major advancements in GAI with a specific focus on GAI production fundamentals and LLMs. Expanding upon these fundamentals, the structure of our survey can be depicted as in Figure 1.

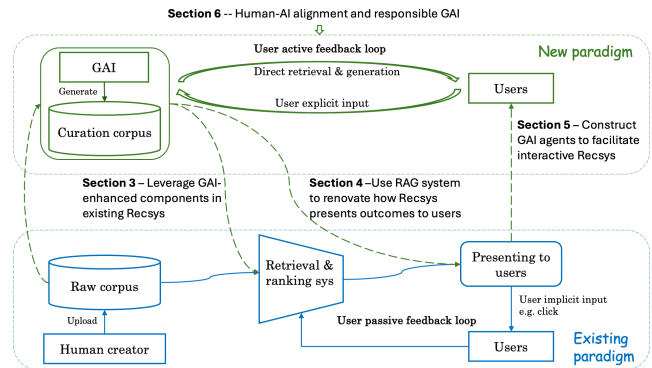

Figure 1: Structure of the survey.

In Section 3, we start with mapping the opportunity landscape of using GAI usecases to enhance **personalized recommendation** – the cornerstone of user satisfaction in the existing Recsys paradigm [109]. After exploring the opportunities and initiatives, we address practical considerations and solutions for integrating the promising ones into real-world production systems.

<sup>1</sup>Subsequent versions of this manuscript will be released with additional real-world examples and solution details after clearing the review process.

In Section 4, we delve deeper beyond personalized retrieval and ranking, focusing on the utilization of GAI for **Recsys curation**. This new landscape entails such as re-purposing raw contents, curating from external knowledge, and generating explanations to precisely address users' varied information need and enhance transparency and trustworthiness – the other crucial dimensions of user satisfaction in social and e-commerce Recsys [45, 93, 125]. Drawing from our experience in deploying these strategies on real-world platforms, we present systematic approaches to facilitate **retrieval-augmented generation** (RAG) within Recsys accompanied by detailed solutions pertaining to AI modeling, serving, LLMOps, and other practical considerations.

Section 5 is devoted to equipping Recsys with **AI agents** to facilitate **interactive recommendation** and **active feedback** loops, marking a departure from the prevailing passive feedback paradigm. By harnessing more advanced tool-using and sequential reasoning-acting capabilities [123, 148], Recsys agents can be engineered to not only suggest items and offer content curation and explanation, but also processing and responding to the explicit, free-form user asks and preference statements. This approach serves to bridge existing gaps and potentially exceed the capabilities and user experiences offered by contemporary conversational Recsys [56].

In Section 6, we review two pivotal challenges associated with deploying GAI in customer-facing applications: **responsible GAI** and **human-AI alignment** [65, 163]. We present the strategies employed by industry applications to navigate the intricate landscape and address the multifaceted aspects of these challenges. Subsequently, in Section 7, we summarize and discuss the practical challenges and problems that have surfaced during our endeavors to land GAI in Recsys.

## 1.2 Key Contributions and Distinguishing from Related Works

While several academic surveys have been conducted on the research intersection between LLM/GAI and Recsys [35, 81, 84, 138], there has *not* yet been a review addressing the integration and development of GAI within real-world Recsys. This survey work goes beyond previous works by not only covering new aspects such as *system architecture*, *LLMOps*, *GAI production framework design*, but also establishes links between practical application and a broader spectrum of GAI topics such as human-AI alignment and responsible AI practices. Additionally, we explore the unresolved challenges faced in real-world practice outside the confines of research labs.

## 2 BACKGROUND AND FUNDAMENTALS

This section aims to offer a concise overview of the foundational components of industrial Recsys and the merging GAI ecosystem, with an emphasis on the practical *operational* aspects inherent in real-world compound AI systems.

### 2.1 Industrial Recsys in a Nutshell

For all major social and e-commerce platforms, user satisfaction and commercial value growth often hinge upon the efficacy of Recsys in meeting increasingly challenging business goals [2, 92, 150, 156]. As we illustrate in Figure 2, modern industrial Recsys have evolved into *compound AI systems*, comprising of multiple components that

exhibit intricate interplay. The necessity of using compound AI systems stems from several factors.

- The business and performance goals of industrial Recsys are *dynamic* and *vary widely*. Compound AI systems can adapt quickly due to their modular structure and operational flexibility.
- For a wide array of real-world tasks, constructing components and managing their interplay within the existing system often lead to *simpler* and more *cost-effective* solutions.
- Compound AI systems offer *finer levels of control* throughout the product lifecycle, including development, integration, testing, trouble shooting, and maintenance.

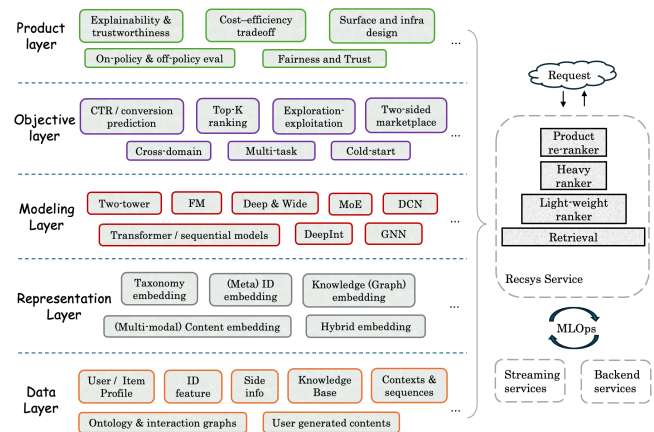

**Figure 2: Overview of the key components employed by modern industrial social and e-commerce Recsys. The modeling stack typically consists of data, representation, modeling, objective, and product layers. The infra stack often comprises diverse serving, streaming, backend serveries orchestrated using MLOps techniques.**

As subsequently demonstrated in this survey, incorporating GAI solutions also necessitates a holistic approach with *system thinking*. This entails considering the current system architecture, infrastructural limitations, operational capabilities, and product/service-level agreements to avoid unintended consequences. Conversely, GAI solutions can capitalize on the mature solutions including reusable components and design patterns inherent in existing Recsys.

### 2.2 Major Deficiencies of Existing Systems

GAI and foundation models can effectively address several major Deficiencies presented in many existing industrial Recsys:

- **Insufficient open-world memorization and generalization** – the memorization and generalization (which are the foundations of personalization) of most social and e-comm Recsys relies primarily on members' in-app/web data and engagements.
- **Lack of active content curation** – industrial social and e-comm Recsys are typically designed to passively retrieve and rank raw contents, with minimum focus on repurposing and curating contents to meet user's highly diversified information indeed.
- **Absence of interactive reasoning** – the majority of industrial Recsys operate within the one-shot engagement paradigm and

are unable to facilitate interactive reasoning regarding the scene, context, user need, explanation, etc.

### 2.3 Building GAI Foundation and LLMops

Developing and serving GAI can involve *modeling*, *infrastructure*, and *operational* components that are not readily available in Recsys. We provide a comprehensive overview in Figure 3 and 4 that is in accordance with the scope of this tutorial.

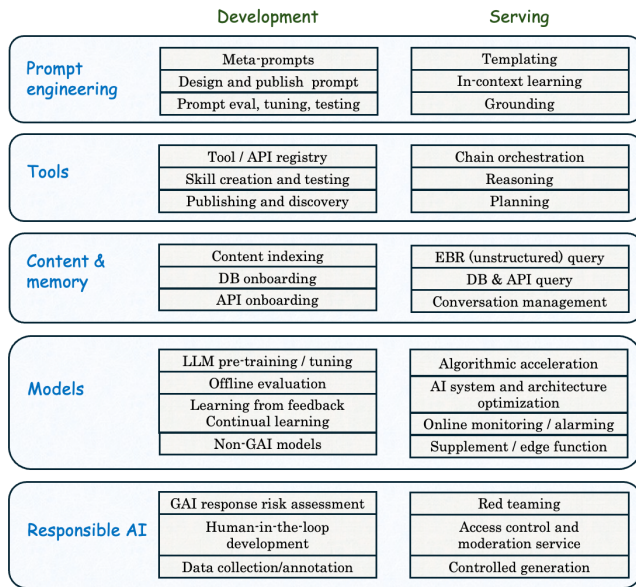

Figure 3: Illustration of the GAI foundations that will be the focus areas of our tutorial.

2.3.1 *GAI ecosystem*. Prompt engineering is an effective approach to direct LLM towards producing desired outcome for specific tasks. Prompting LLM and applying relevant techniques like in-context learning, chain-of-thought, and other enhancements has rapidly become essential for adopting LLM for specific tasks [84, 91, 127, 131, 158]. Figure 3 provides a summary of the elements required for implementing prompt engineering solutions in production, which we will elucidate throughout the remainder of this survey.

Prompting LLMs can be further endowed with *tool-using* capabilities [113, 145], enabling them to address compositional tasks through chains of *reasoning and action* [148]. This also catalyzed the development of LLM-based autonomous agents that integrate planning, memory (including content comprehension), and tool utilization [12, 123, 140]. In Figure 3, we illustrate the requisite services and functions for accessing the internal and external services, tools, and memory within production systems.

While prompt engineering has demonstrated reasonable proof-of-concept results across various tasks, scaling up and ensuring sustainability of GAI solutions often requires **GAI model optimization**, which is a key direction to address cost, latency, and the effective usage of proprietary data and domain knowledge. Fortunately, task-specific GAI model development is often simpler through effective fine-tuning [49, 79] and learning from human

feedback [96, 104]. Training GAI solutions from scratch is often less undesired [11, 105]. Serving up GAI deployment usually involves a collaborative refinement of the algorithm (e.g. through model compression, sparsity, operator fusion, distillation, pruning, efficient decoding techniques [60, 94, 102, 152]) and the AI system architecture (e.g. with quantization, PagedAttention, parallel computation [71, 90]). Finally, we mention that non-GAI models will remain essential in the ecosystem as *supplement and edge functions*.

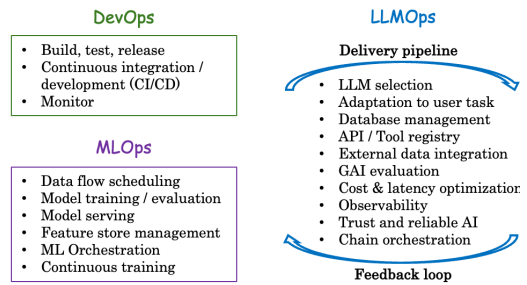

Figure 4: Overview of DevOps, MLOps, and LLMops. The key LLMops terms will be clarified in the rest of this survey.

2.3.2 *LLMops*. Similar to other internet applications, delivering GAI products that can meet client expectations remains a significant challenge unless the workflows can be effectively automated and operationalized. This is addressed within the domain of LLMops (as we outlined in Figure 4), which represents an evolution of *development operations* (DevOps) and *machine learning operations* (MLOps) [55, 70]. In addition to leveraging insights from the previous generation of software and machine learning product development, there are several new practices and concepts crucial for harnessing and managing the power of GAI. The most critical ones include *GAI evaluation* and the *trust and responsible GAI* [6, 18], which will be further elaborated in the next sections.

### 2.4 Classification Framework of GAI in Recsys

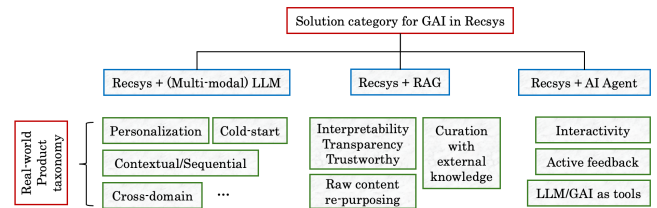

Figure 5: Real-world product taxonomy of social/e-commerce Recsys and they best fit into the major solution categories of GAI in Recsys solutions.

Emphasizing *practicality* and *feasibility* in real-world deployment, our taxonomy and classification framework (depicted in Figure 5) is organized by: 1). real-world production tasks of social and e-commerce Recsys, 2). their *optimal realization* through three primary categories of GAI methods. Notably, our framework is *application-centric*, thus facilitating a comprehensive examination of the deployment of GAI in real-world Recsys.

### 3 GAI-ENHANCED DATA, FEATURE, AND MODELING FOR RECSYS

For most existing social and e-commerce Recsys, the goal of recommendation is to identify good matches and tailor contents and experiences to best align with *personalized preferences* [109]. Given GAI's unprecedented capability to process complex multi-modal user-item information/context/sequences [75, 112, 151], solve cold-start/few-shot problems [33, 47], and serve as various other components outlined in Figure 2, several preliminary studies have recognized the potential of GAI to augment personalized recommendation.

#### 3.1 Research Progress

In Figure 6, we present a comprehensive overview of the predominant trends in existing efforts, where the *data and feedback processing* and *feature engineering* stages are also taken into account. The key advancements in applying GAI for data and feedback processing include enriching user/item profile extraction and tagging [10, 73], comprehending user intent and interests [23], condensing and augmenting data [137], integrating external knowledge [20, 149], and simulating and generating records [124]. We note that there is a growing body of literature on using Agent as Recsys user simulator [124, 153, 155], which represents an alternative application of agents to the one we will present in Section 5.

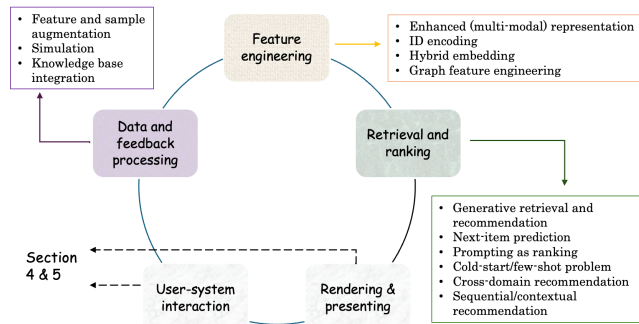

**Figure 6: Overview of the predominant trends of using GAI to improve personalized retrieval and ranking in social and e-commerce Recsys. We also include rendering and interaction stages in the circle for completeness.**

For *feature engineering*, Recsys primarily utilize sparse categorical features and their representations. Through not entirely GAI-driven, the advent of LLM has presented opportunities to further improve representation learning especially for textual features and multi-modal data [108, 112, 160]. Graph data has also been introduced to enhance LLM's capability to generate high-quality representations [133, 141]. Recent studies have proposed using LLM for ID-based representation of users and items [41, 50].

GAI techniques have also been explored for *retrieval and ranking tasks*. Generative retrieval and recommendation has emerged as a promising domain where GAI directly generates item IDs as output [106, 117, 142]. Some studies also follow NLP approaches to use GAI for top-K recommendation [27]. Other major directions include context-aware recommendation where GAI's world knowledge can

serve as important background information [44, 139]. For a more detailed examination of this subject, please refer to the comprehensive surveys of Lin et al. [81] and Wu et al. [138].

#### 3.2 Solution Framework and Practical Considerations

Since the subject matter addressed in this section usually represent the initial attempts of adopting GAI to the offline development of real-world Recsys, investing in GAI foundation and LLMOps (especially the offline elements described in Figure 3 and 4) can substantially expedite GAI-in-the-loop endeavors in the future. During this stage, latency is typically not a significant obstacle for batch offline inference, and prompt engineering/fine-tuning LLM can often deliver tangible improvements across various tasks [84]. Furthermore, the existing metrics and frameworks for offline and online Recsys evaluation are still applicable [17, 69], as the final forms of recommendation remains unchanged.

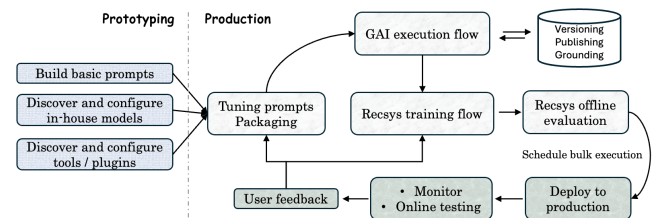

**Figure 7: A standard workflow for productionizing prompt engineering solution for enhancing Recsys training.**

Nevertheless, while leveraging prompt engineering for the development of novel features may seem straightforward, ensuring the seamless transition of temporary prototypes to large-scale production necessitates *operational strategies* (see Figure 7). This process entails the construction of an end-to-end pipeline that facilitates effectively prompt tuning and evaluation [86], versioning and publishing prompts [136], and grounding and monitoring to ensure the correct services and contexts are triggered and utilized.

In practice, we have observed that using "small" in-house and task-specific GAI models can offer cost and performance advantage over using the open "large-model" solutions. This finding is substantiated by the fact that many smaller-scale applications usually do not require GAI excelling at both task specialization and generation [8, 114]. Nevertheless, ensuring the efficacy of "small" models often require model fine-tuning and alignment with proprietary data, as well as the development of instruction, demonstration, and in-context learning strategies [84, 86, 91]. These important aspects are also revealed from the recent industrial efforts [26, 35].

Lastly, we note that personalized recommendation has been extensively studied in the past two decades, leading to many practical and effective domain methods [67, 99]. Considering the maturity and efficacy of many time-tested industrial Recsys, the potential value of integrating GAI may be more pronounced in domains where existing RecSys exhibit limitations. These areas will be explored in detail in the subsequent sections.

## 4 AUGMENTING THE CURATION CAPABILITY OF RECSYS

Beyond enhancing personalized retrieval and ranking, GAI-powered curator allows Recsys to transcend the limitation of only showing human-generated contents. It enables **re-purposing**, **explaining**, and **curating contents using external knowledge** to meet diversified needs and elevate transparency and trust [125, 126, 128].

However, using GAI to directly generate customer-facing contents can suffer from *inadequate knowledge* of both the user and subject matter, *limited task expertise*, *lack of control of the output*, and various other *trust and safety issues* that cannot be fully addressed through improving prompting or model tuning techniques [15, 52, 100]. As our earlier discussions suggest, building compound AI system can be a pragmatic approach to systematically address the above challenges, which leads to our introduction of the *retrieval-augmented generation* (RAG) – a technique that integrates external data retrieval into the generative process [72, 74].

### 4.1 Research Progress

Until not long ago, Recsys' curation capability (e.g. explanation generation) primarily relies on the efficacy of templates and manual curation [77], which often lack richness and in-depth context comprehension and knowledge. RAG systems combine the strengths of retrieval-based and GAI-based methods to enhance the accuracy, credibility, and relevance of the GAI outputs for various Recsys usages [32]. The scope of retrieval can extend beyond user-generated content to, for example, behavioral sequences [82]. We provide a concise overview of RAG system in Figure 8.

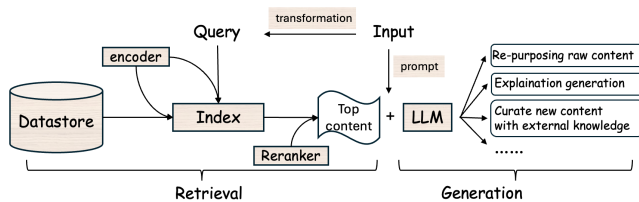

**Figure 8: Illustration of a typical RAG system marked with the areas that can be optimization within the system.**

RAG is a rapidly developing technique (with variants such as self-RAG, auto-RAG, Corrective RAG) where the workflow is further improved by adding components like retrieval result verification and re-ranking [78, 143, 161], adaptive retrieval [59], and query rewrite [88]. Typically, incoming requests are first parsed into queries and prompts. The queries are directed to the retrieval and re-ranking service (with pre-trained encoder and datastore index) to retrieve the most relevant contents. The contents are subsequently leveraged to improve generation by such as *enriching/augmenting* the input prompts and *correcting* LLM's output.

It is noteworthy that the output of RAG can be *multi-modal*, including images (including attribute change of existing images and stylized images) and videos, through the integration of diffusion and CLIP models [103, 110]. The *adaptability* and *versatility* of RAG have positioned it as a prominent GAI solution, particularly suited for tasks requiring integration with excessive knowledge. [38]. As

we will demonstrate in the subsequent section, RAG also holds promise for effective utilization by AI agents.

### 4.2 Solutions Framework and Practical Considerations

Despite that RAG shares several common building blocks with Recsys and holds promising benchmark results [19], implementing and integrating RAG into Recsys presents significant challenges in practice. We summarize them into three folds as below, and present an overview of the solution framework in Figure 9. Generally, addressing these challenges requires system-level solutions.

- (1) **evaluation** – unlike evaluating item recommendations, assessing curation outcome in Recsys is often feasible only during runtime, and the metric taxonomy for *natural language generation* (NLG) differs from that of RecSys [111, 159];
- (2) **deployment** – deploying RAG within the service-level agreement (SLA) of Recsys necessitate optimizations across algorithm, AI system, and the serving infrastructure;
- (3) **building and refining RAG** involve fostering synergies among multiple interacting components, both offline and online.

**4.2.1 Evaluating RAG performance offline.** RAG system is difficult to evaluate offline because of the dependency on real-time and operation contexts. We have found the application of *canary testing*, a technique derived from DevOps practices [119], along with synthetic generation to be effective. Canary testing enables the real-time performance tracking of RAG by replicating online requests within the same context without impacting user experience. Leveraging the tracked events, we can synthesize records and conduct various NLG evaluations, such as employing BLEU, ROUGE, and other hallucination metrics [39, 57], and performing risk assessment (refer to Section 6 for further detail).

In contrast to traditional NLG tasks like translation, summarization, and open-book Q&A, there lacks well-established evaluation solutions for such as *explanation generation* for Recsys. Our practical experience suggests that expert evaluation, even on a modest scale, proves highly effective. Nonetheless, it is crucial to establish explicit standards and guidelines to minimize ambiguities and misunderstandings during expert evaluation [48]. Lastly, standard relevance metrics such as precision@k and recall@k can be helpful for specific tasks where ground truth is available.

**4.2.2 Development.** For **building** the initial RAG solution, a typical roadmap involves two phases:

- **offline** – constructing data stores along with the development of the encoder and index for each data store [64];
- **online** – setting up execution flows for query processing, chunk re-rank/process/consolidate, and prompting LLM [9, 43].

Following these phases, the RAG system can be encapsulated as a standalone service module, responsible for managing incoming requests from the RecSys (as illustrated in Figure 9).

**4.2.3 Deployment.** Given that social and e-commerce Recsys often adhere to stringent SLA [66], may encounter challenges in meeting these SLAs when handling inputs or outputs of moderate lengths. As elaborated in Section 2, optimizing LLM inference typically involves a combination of algorithmic and AI system enhancements

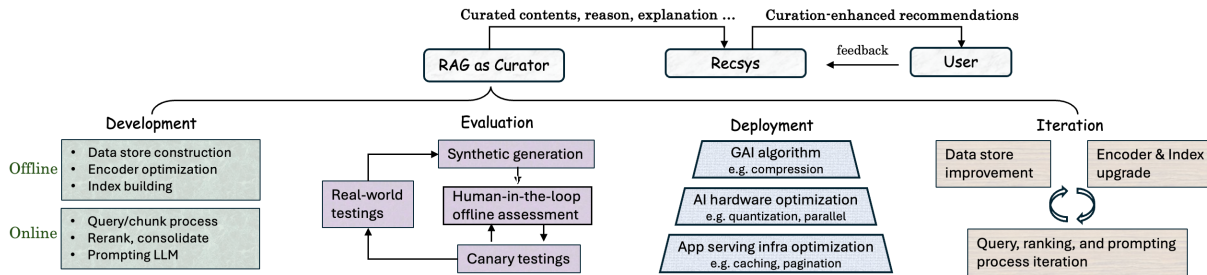

Figure 9: Taxonomies and overview of the solution framework for building RAG as GAI curator in Recsys.

[90]. Each of these methods entails its own trade-offs, so their efficacy should be discussed case-by-case. In practice, we have found adopting traditional web service optimization techniques, such as dynamic caching and pagination, proves valuable for circumventing the SLA [14, 36]. Furthermore, these techniques have been adapted to specifically support LLM applications [5].

4.2.4 *Iteration.* Iterating and refining RAG solution post-launch often involve encoder and index update through sequential and asynchronised/batch training, improving the data store, and optimizing the querying process, chunk processing logic, and prompting strategies [54]. These components are also highlighted in Figure 8.

However, it is noteworthy that directly optimizing RAG based on *implicit* feedback from the recommendations, such as clicks, can be challenging due to the feedback being attributed to a combination of raw and curated contents. Consequently, establishing explicit and active feedback loops for *richer* user feedback can benefit the optimization of GAI curator in Recsys. This topic will be further explored in the next two sections.

## 5 FACILITATING ACTION AND REASONING FOR INTERACTIVE RECSYS

Within the current Recsys paradigm, user engagement is generally facilitated via single-round, passive interactions through a constrained set of predefined mechanisms, including item icon clicks or search bar queries [2, 109]. This framework is tailored for scenarios in which passive feedback is considered sufficient for both user satisfaction and business objectives.

However, such Recsys often lack ability to drive active interactions or leverage external tools (e.g. to access external knowledge bases) to further engage and satisfy users. Consequently, their applicability is restricted, and cannot generalize across recommendation scenarios or to meet emerging user demands for **interactivity** and participating in **active feedback** loops. To address these shortcomings, we advocates for the augmenting RecSys with autonomous AI agent, harnessing their robust natural language reasoning capabilities and tool utilization proficiency [123, 140], in conjunction with the GAI solution frameworks discussed in Section 3 and 4.

### 5.1 Research Progress

From Section 3 and 4, we see that GAI can indeed enable interactive recommendations by curating human-like responses for various tasks such as direct recommendation, preference refinement, recommended follow-up questions, and recommendation justification

[51, 56]. AI agents can be employed to manage and orchestrate these interactive components [30, 129]. In fact, the RAG system introduced in Section 4 can be considered a simple AI agent with retrieval and generation modules.

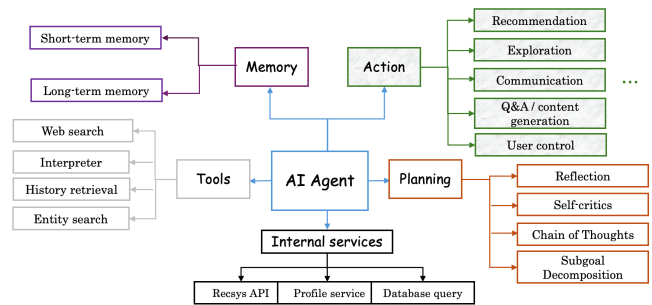

Figure 10: Illustration of the components and capabilities of an AI agent for typical social and e-commerce scenarios.

LLM-powered AI agents can utilize LLM to reason through problems, create plans, produce text-based outputs and actions, and interact with external tools via API calls. The *planning* aspect can be facilitated by either providing the agent with a predefined reasoning graph, as discussed in [144], by harnessing LLM’s reasoning abilities to dynamically generate the reasoning path [131]. For *actions*, the agent can generate textual outputs following the decision-making processes regarding whether and how to engage with a particular tool [113]. Recent research has delved into both of these capabilities for Recsys [53, 129].

### 5.2 Solution Framework and Practical Considerations

We start by conceptualizing an AI Agent (as shown in Figure 10) that is equipped with a diverse array of capabilities to facilitate interactive recommendation processes. Depending on the product design and requirement, the planning module can be one of the two types, where the main difference lies in how planning is executed: *predefined* or *generated in real time*.

5.2.1 *Agent with pre-defined reasoning graph.* We outline one example in Figure 11 where the pre-defined reasoning graph is applied, and the role of LLM is to make decisions on how to navigate the graph and use tools to execute each step along the sequence. This

type of Agent is designed to minimize latency, cost, and *operation overhead* – instead relying on LLM to generate outputs for a function call, we apply rules and light-weight supplement models for decision-making. However, this approach is mostly suitable for simpler applications with small action spaces. Also, creating a predefined reasoning graph also requires domain expertise, and many not be applicable in certain scenarios.

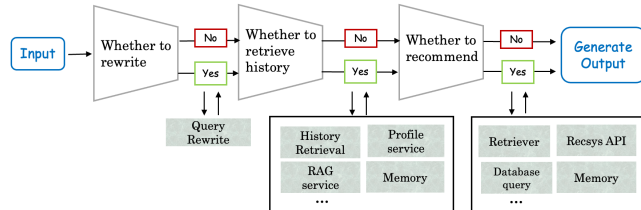

Figure 11: Example of Type-1 GAI agent with pre-defined reasoning graph for in-session recommendation tasks.

5.2.2 *Agent that uses GAI for planning.* Techniques like chain-of-thoughts [131] or tree-of-thoughts [147] can be adopted to prompt LLM to generate reasoning paths on-the-fly. GAI planning can effectively *supplement* pre-defined reasoning for the long-tail behaviors and events. For further illustration, in Figure 12 and the following paragraphs, we outline an interactive Recsys agent that enables seamless user engagements and active feedback.

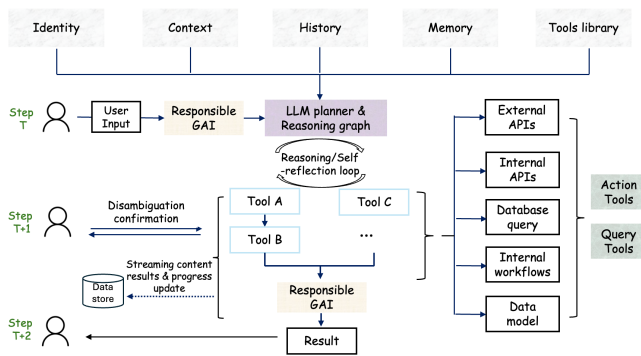

Figure 12: Overview of a real-world Recsys agent for multi-round interactive social recommendation. The Responsible GAI component will be discussed in Section 6.

Depending on the product and task requirements, there are practical considerations for setting up the action phase.

- **Database query and Recsys API call** – we discovered significant efficacy in developing LLM-oriented domain-specific language (DSL) [89] that can be effectively translated into appropriate text2sql queries and API calls. When combined with standard few-shot learning and in-context learning/retrieval in run-time, the tool-using performance notably surpasses alternative options for getting data and recommendations.
- **LLM tools** – to enable input augmentation, text summarization, and response generations, with "small" LLM such as *Llama-7B* [121] and *Mistral-7B* [58] typically being sufficient for these tasks.

- **RAG tools** – to facilitate the various Recsys curation functionalities described in Section 4.
- **Intent and ambiguity classification models** – ambiguities in user input can lead to failures in agents' planning process in practice. Using supplement models to characterize intents and ambiguity can enable agents to communicate with users for precise instructions.
- **Internal workflow and session data models** – for real-time accessing and acting on the serving infrastructure such as data store (cache), schemas, streaming services, and more.

Lastly, the evaluation and continual optimization of Recsys agents involve more elements than what we outlined for RAG in Section 4.2. Many of the aspects require thorough examination, and we will elaborate them in the next sections.

## 6 RESPONSIBLE GAI AND HUMAN-AI ALIGNMENT

In social and e-commerce platforms, *trust* and *safety* stand out as the top product requirements for incorporating and serving LLM, RAG, and AI agents in Recsys. Subsequent changes are introduced to the offline evaluation and AI improvement strategies. In particular, *risk assessment* of the generative outputs adds more dimensions to the traditional metrics like relevance, and *aligning* GAI to user preferences also necessitates a considerable expansion of the current serving and offline training strategies of Recsys.

### 6.1 Trust and Responsible AI

Several identified attributes of GAI outputs can violate the trust and responsible AI principles, especially concerning *bias* and *toxicity* [40], *privacy* [15], and *hallucination* [107]. It has also been found that LLM are subject to adversarial attacks with crafted inputs, e.g. *jailbreak prompts*, to trigger undesired output [163].

There are active investigations on the causes and modeling and data solutions of these issues [28, 115, 130, 135]. But as we mentioned in Section 1, compound AI system has natural advantages in improving control and trust, and our tutorial will focus on introducing **system-level** solutions, especially:

- Adopting **Red Teaming**, which uses a "Red LLM" to regulate the behavior of the target LLM [98], has been demonstrated highly effective to alleviate both the bias and toxicity issues as well as preventing adversarial attacks and privacy leakage [16, 37].
- Incorporating system layers that use RAG (with knowledge base) or domain LLM and expert tools can often provide practical solutions to mitigate the hallucination problems [120, 157].

In practice, the above solutions and related components constitute the **Trust & Responsible GAI service**, which we elaborate in Figure 13. After integrated with the existing API and environment manager, the service will apply to both the input and output stage of the generation process and is responsible for communicating with the clients through response handling.

### 6.2 GAI response risk assessment

Alongside the service-time guardrails solutions to ensure responsible GAI, offline risk assessment of the generated contents is also

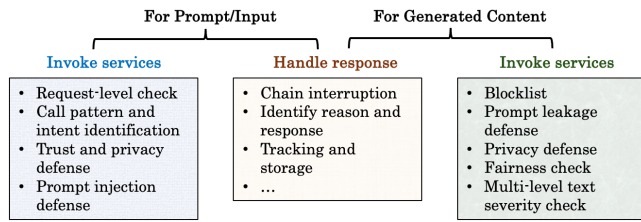

**Figure 13: Core components of the Trust & Responsible GAI service to support the various system-level solutions to bias, toxicity, privacy and adversarial attach issues.**

critical for safeguarding prompting, RAG, and agent solutions in Recsys by ensuring *reliability* and *trustworthiness* [18, 154].

We specifically focus on assessing the risk perspective of GAI including ethical and bias issues and trust violations, given their crucial importance as product safeguards. Both conventional NLP testing approaches and innovative multifaceted exploration has been conducted to evaluate GAI’s toxicity, social bias, and trustworthiness vulnerabilities [31, 40, 97, 122, 162].

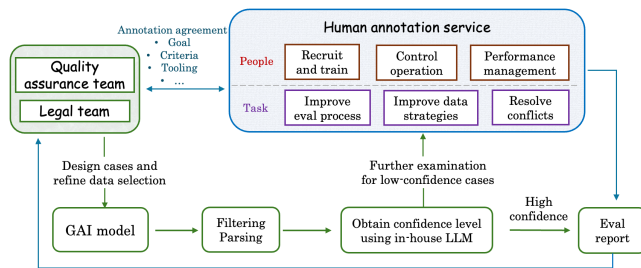

**Figure 14: Workflow of human-in-the-loop response risk assessment for RAG and AI agent in Recsys. It can be applied to generic natural language generation evaluation [48, 159].**

While those research probe the problem from different angles, a common consensus underscores the necessity of *dedicated* evaluation datasets and *human-in-the-loop* assessments [18]. In Figure 14, we characterize a typical industrial service workflow for human-in-the-loop evaluation of GAI response risk assessment.

### 6.3 Human-AI alignment for GAI in Recsys

In the course to machine learning, AI alignment has shown up explicitly before in the field of Recsys and information retrieval where learning-to-rank from bandit feedback and user preference have been studied intensively [1, 61, 76, 85]. As we summarized in Figure 15, there is non-trivial overlap between the Recsys and GAI methodological topics in the broader human-AI alignment domain.

However, there are fundamental differences – for GAI, alignment problems are generally refer to *behavior alignment*, aiming create an agent that behaves in accordance with human instructions and values [65, 96]. For Recsys, the alignment emphasizes more on matching and exploring human preferences and interests.

Clearly, introducing new criteria, objectives, and techniques from GAI will be beneficial. For example, the *Helpful, Honest, Harmless* criteria proposed by Lin et al. [83], the adoption of *reinforcement*

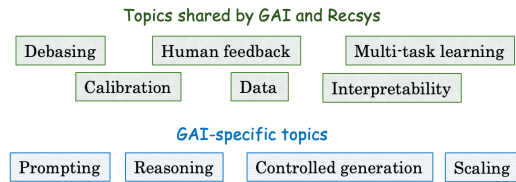

**Figure 15: Some key directions for improving Human-AI alignment for GAI in Recsys.**

*learning from human feedback* (RLHF) and *direct preference optimization* (DPO) to achieve these criteria [4, 104], and the various technical directions outlined in Bai et al. [4]. Another crucial aspect lies in **user interface design** and **communication strategies** [134], as they can influence, regulate, incentivize, and direct users towards providing explicit preferences for continual learning through the aforementioned methods.

Understanding the cause of *misalignment* in GAI can also go a long way. Specifically, the emerging GAI capabilities are often attributed to the scaling law and extensive pre-training corpus [12, 63], so building insights to the data and model scaling properties can be critical for diagnosing issues and identifying opportunities [7, 34, 46]. A comprehensive solution can therefore incorporate both the traditional wisdom of *data cleaning*, *debiasing*, *multi-task learning*, as well as contemporary GAI techniques like calibration of prompting [158] and reasoning with self-consistency [127]. Additionally, enforcing *controlled generation* by such as Red Teaming is also a practical approach for human-AI alignment.

## 7 OPEN PROBLEMS

In the course of landing GAI in Recsys, we have faced several universal challenges on top of the application-specific problems outlined in the previous sections. Here, we emphasize a selection of these that hold particular practical significance and opportunity.

**Effective in-house GAI serving stack** – for industrial systems, GAI *cost* and *latency* (especially those from the long input and token generation) significantly impact the experience of both developers and users when adopting GAI at the scale of Recsys, and within the constraints of existing service-level agreements. [21, 25, 95, 102]. Developing a systematic solution remains challenging despite the recent research advances in LLM serving [90].

**Imitating LLM on proprietary data and models** – constructing compact models that strikes a balance between *task imitation* with proprietary model and structured data, alongside LLM’s *generation capability*, can be instrumental for overcoming the computational and resource challenges while ensuring optimal efficiency and effectiveness for specific applications [24, 42, 62].

**High-quality human data** – high quality data is the fuel for all stages in the GAI and Recsys development cycles. Unlike Recsys which can leverage a wide range of user feedback, the majority of task-specific labeled data for GAI training and evaluation is obtained through *human annotation*, including tasks such as classification or RLHF labeling for LLM alignment training. While numerous machine learning techniques can contribute to enhancing data quality, human data collection fundamentally relies on attention to detail and careful execution [3, 13, 29, 101].



**Online evaluation and monitoring for GAI in Recsys** – while the Recsys community has developed mature and sophisticated solutions for online controlled experiments [68–70], with the introduction of GAI, measuring online performance is confronted with challenges such as overcoming brittle metrics, measuring generative task performance at scale, ensuring reproducibility, and coming up with the appropriate monitoring and experimental designs for both user satisfaction and system efficiency [22, 80, 87, 116].

## 8 CONCLUSION

In this survey, we provide a comprehensive review of the promising initial attempts at integrating GAI into social and e-commerce Recsys. We traverse the landscape of industrial Recsys and GAI fundamentals, existing solution frameworks, their connections to research advancements, and the practical insights and challenges encountered. As a pioneering contribution in this field, our survey also serves as a guide for incorporating GAI into a broader range of industrial Recsys. Moreover, it benefits scholars and practitioners in both the GAI and Recsys communities by delineating clear practical roadmaps for embedding GAI into real-world applications.

## REFERENCES

- [1] M Mehdi Afsar, Trafford Crump, and Behrouz Far. 2022. Reinforcement learning based recommender systems: A survey. *Comput. Surveys* 55, 7 (2022), 1–38.
- [2] Charu C Aggarwal et al. 2016. *Recommender systems*. Vol. 1. Springer.
- [3] Lora Aroyo and Chris Welty. 2015. Truth is a lie: Crowd truth and the seven myths of human annotation. *AI Magazine* 36.1 (2015).
- [4] Yuntao Bai, Andy Jones, Kamal Ndousse, Amanda Askell, Anna Chen, Nova DasSarma, Dawn Drain, Stanislav Fort, Deep Ganguli, Tom Henighan, et al. 2022. Training a helpful and harmless assistant with reinforcement learning from human feedback. *arXiv preprint arXiv:2204.05862* (2022).
- [5] Fu Bang. 2023. GPTCache: An open-source semantic cache for LLM applications enabling faster answers and cost savings. In *Proceedings of the 3rd Workshop for Natural Language Processing Open Source Software (NLP-OSS 2023)*. 212–218.
- [6] Kathy Baxter and Yoav Schlesinger. 2023. Managing the Risks of Generative AI. <https://hbr.org/2023/06/managing-the-risks-of-generative-ai>. (2023).
- [7] Emily M Bender, Timnit Gebru, Angelina McMillan-Major, and Shmargaret Shmitchell. 2021. On the dangers of stochastic parrots: Can language models be too big?. In *Proceedings of the 2021 ACM conference on fairness, accountability, and transparency*. 610–623.
- [8] Rishi Bommasani, Drew A Hudson, Ehsan Adeli, Russ Altman, Simran Arora, Sydney von Arx, Michael S Bernstein, Jeannette Bohg, Antoine Bosselut, Emma Brunskill, et al. 2021. On the opportunities and risks of foundation models. *arXiv preprint arXiv:2108.07258* (2021).
- [9] Sebastian Borgeaud, Arthur Mensch, Jordan Hoffmann, Trevor Cai, Eliza Rutherford, Katie Millican, George Bm Van Den Driessche, Jean-Baptiste Lespiau, Bogdan Damoc, Aidan Clark, et al. 2022. Improving language models by retrieving from trillions of tokens. In *International conference on machine learning*. PMLR, 2206–2240.
- [10] Alexander Brinkmann, Roece Shraga, Reng Chiz Der, and Christian Bizer. 2023. Product Information Extraction using ChatGPT. *arXiv preprint arXiv:2306.14921* (2023).
- [11] Tom Brown, Benjamin Mann, Nick Ryder, Melanie Subbiah, Jared D Kaplan, Prafulla Dhariwal, Arvind Neelakantan, Pranav Shyam, Girish Sastry, Amanda Askell, et al. 2020. Language models are few-shot learners. *Advances in neural information processing systems* 33 (2020), 1877–1901.
- [12] Sébastien Bubeck, Varun Chandrasekaran, Ronen Eldan, Johannes Gehrke, Eric Horvitz, Ece Kamar, Peter Lee, Yin Tat Lee, Yuanzhi Li, Scott Lundberg, et al. 2023. Sparks of artificial general intelligence: Early experiments with gpt-4. *arXiv preprint arXiv:2303.12712* (2023).
- [13] Chris Callison-Burch. 2009. Fast, cheap, and creative: Evaluating translation quality using Amazon’s Mechanical Turk. *Proceedings of conference on empirical methods in natural language processing* (2009).
- [14] Pei Cao, Jin Zhang, and Kevin Beach. 1998. Active cache: Caching dynamic contents on the web. In *Middleware’98: IFIP International Conference on Distributed Systems Platforms and Open Distributed Processing*. Springer, 373–388.
- [15] Nicholas Carlini, Florian Tramèr, Eric Wallace, Matthew Jagielski, Ariel Herbert-Voss, Katherine Lee, Adam Roberts, Tom Brown, Dawn Song, Ulfar Erlingsson, et al. 2021. Extracting training data from large language models. In *30th USENIX Security Symposium (USENIX Security 21)*. 2633–2650.
- [16] Stephen Casper, Jason Lin, Joe Kwon, Gatien Culp, and Dylan Hadfield-Menell. [n. d.]. Explore, Establish, Exploit: Red Teaming Language Models from Scratch, June 2023b. URL <http://arxiv.org/abs/2306.09442> ([n. d.]).
- [17] Pablo Castells and Alistair Moffat. 2022. Offline recommender system evaluation: Challenges and new directions. *AI magazine* 43, 2 (2022), 225–238.
- [18] Yupeng Chang, Xu Wang, Jindong Wang, Yuan Wu, Linyi Yang, Kaijie Zhu, Hao Chen, Xiaoyuan Yi, Cunxiang Wang, Yidong Wang, et al. 2023. A survey on evaluation of large language models. *ACM Transactions on Intelligent Systems and Technology* (2023).
- [19] Jiawei Chen, Hongyu Lin, Xianpei Han, and Le Sun. 2023. Benchmarking large language models in retrieval-augmented generation. *arXiv preprint arXiv:2309.01431* (2023).
- [20] Jiao Chen, Luyi Ma, Xiaohan Li, Nikhil Thakurdesai, Jianpeng Xu, Jason HD Cho, Kaushiki Nag, Evren Korpeoglu, Sushant Kumar, and Kannan Achan. 2023. Knowledge graph completion models are few-shot learners: An empirical study of relation labeling in e-commerce with llms. *arXiv preprint arXiv:2305.09858* (2023).
- [21] Lingjiao Chen, Matei Zaharia, and James Zou. 2023. Frugalgpt: How to use large language models while reducing cost and improving performance. *arXiv preprint arXiv:2305.05176* (2023).
- [22] Lingjiao Chen, Matei Zaharia, and James Zou. 2023. How is ChatGPT’s behavior changing over time? *arXiv preprint arXiv:2307.09009* (2023).
- [23] Konstantina Christakopoulou, Alberto Lalama, Cj Adams, Iris Qu, Yifat Amir, Samer Chucr, Pierce Vollucci, Fabio Soldo, Dina Beseio, Sarah Scodel, et al. 2023. Large language models for user interest journeys. *arXiv preprint arXiv:2305.15498* (2023).
- [24] Hyung Won Chung, Le Hou, Shayne Longpre, Barret Zoph, Yi Tay, William Fedus, Yunxuan Li, Xuezhi Wang, Mostafa Dehghani, Siddhartha Brahma, et al. 2022. Scaling instruction-finetuned language models. *arXiv preprint arXiv:2210.11416* (2022).
- [25] MLOps Community. 2023. LLM in production responses. <https://docs.google.com/spreadsheets/d/13wdBwkX8vZrYKuvF4h2egPh0LYSn2GQSwUaLV4GUNAUEdit#gid=501618501>. (2023).
- [26] Zeyu Cui, Jianxin Ma, Chang Zhou, Jingren Zhou, and Hongxia Yang. 2022. M6-rec: Generative pretrained language models are open-ended recommender systems. *arXiv preprint arXiv:2205.08084* (2022).
- [27] Sunhao Dai, Ninglu Shao, Haiyuan Zhao, Weijie Yu, Zihua Si, Chen Xu, Zhongxiang Sun, Xiao Zhang, and Jun Xu. 2023. Uncovering chatgpt’s capabilities in recommender systems. In *Proceedings of the 17th ACM Conference on Recommender Systems*. 1126–1132.
- [28] Sumanth Dathathri, Andrea Madotto, Janice Lan, Jane Hung, Eric Frank, Piero Molino, Jason Yosinski, and Rosanne Liu. 2019. Plug and play language models: A simple approach to controlled text generation. *arXiv preprint arXiv:1912.02164* (2019).
- [29] Mark Diaz Davani, Aida Mostafazadeh and Vinodkumar Prabhakaran. 2022. Dealing with disagreements: Looking beyond the majority vote in subjective annotations. *Transactions of the Association for Computational Linguistics* 10 (2022).
- [30] Yang Deng, An Zhang, Yankai Lin, Xu Chen, Ji-Rong Wen, and Tat-Seng Chua. 2024. Large Language Model Powered Agents in the Web. *learning* 2 (2024), 20.
- [31] Jwala Dhamala, Tony Sun, Varun Kumar, Satyapriya Krishna, Yada Pruk-sachatkun, Kai-Wei Chang, and Rahul Gupta. 2021. Bold: Dataset and metrics for measuring biases in open-ended language generation. In *Proceedings of the 2021 ACM conference on fairness, accountability, and transparency*. 862–872.
- [32] Dario Di Palma. 2023. Retrieval-augmented recommender system: Enhancing recommender systems with large language models. In *Proceedings of the 17th ACM Conference on Recommender Systems*. 1369–1373.
- [33] Hao Ding, Yifei Ma, Anoop Deoras, Yuyang Wang, and Hao Wang. 2021. Zero-shot recommender systems. *arXiv preprint arXiv:2105.08318* (2021).
- [34] Jesse Dodge, Maarten Sap, Ana Marasović, William Agnew, Gabriel Ilharco, Dirk Groeneveld, Margaret Mitchell, and Matt Gardner. 2021. Documenting large webtext corpora: A case study on the colossal clean crawled corpus. *arXiv preprint arXiv:2104.08758* (2021).
- [35] Wenqi Fan, Zihuai Zhao, Jiatong Li, Yunqing Liu, Xiaowei Mei, Yiqi Wang, Jiliang Tang, and Qing Li. 2023. Recommender systems in the era of large language models (llms). *arXiv preprint arXiv:2307.02046* (2023).
- [36] Todd Fredrich. 2012. Restful service best practices. *Recommendations for Creating Web Services* (2012), 1–34.
- [37] Deep Ganguli, Liane Lovitt, Jackson Kernion, Amanda Askell, Yuntao Bai, Saurav Kadavath, Ben Mann, Ethan Perez, Nicholas Schiefer, Kamal Ndousse, et al. 2022. Red teaming language models to reduce harms: Methods, scaling behaviors, and lessons learned. *arXiv preprint arXiv:2209.07858* (2022).
- [38] Yunfan Gao, Yun Xiong, Xinyu Gao, Kangxiang Jia, Jinliu Pan, Yuxi Bi, Yi Dai, Jiawei Sun, and Haofen Wang. 2023. Retrieval-augmented generation for large language models: A survey. *arXiv preprint arXiv:2312.10997* (2023).

- [39] Albert Gatt and Emiel Krahmer. 2018. Survey of the state of the art in natural language generation: Core tasks, applications and evaluation. *Journal of Artificial Intelligence Research* 61 (2018), 65–170.
- [40] Samuel Gehman, Suchin Gururangan, Maarten Sap, Yejin Choi, and Noah A Smith. 2020. Realtoxicityprompts: Evaluating neural toxic degeneration in language models. *arXiv preprint arXiv:2009.11462* (2020).
- [41] Shijie Geng, Shuchang Liu, Zuohui Fu, Yingqiang Ge, and Yongfeng Zhang. 2022. Recommendation as language processing (rlp): A unified pretrain, personalized prompt & predict paradigm (p5). In *Proceedings of the 16th ACM Conference on Recommender Systems*. 299–315.
- [42] Arnav Gudibande, Eric Wallace, Charlie Snell, Xinyang Geng, Hao Liu, Pieter Abbeel, Sergey Levine, and Dawn Song. 2023. The false promise of imitating proprietary llms. *arXiv preprint arXiv:2305.15717* (2023).
- [43] Kelvin Guu, Kenton Lee, Zora Tung, Panupong Pasupat, and Mingwei Chang. 2020. Retrieval augmented language model pre-training. In *International conference on machine learning*. PMLR, 3929–3938.
- [44] Jesse Harte, Wouter Zorgdrager, Panos Louridas, Asterios Katsifodimos, Dietmar Jannach, and Marios Fragkoulis. 2023. Leveraging large language models for sequential recommendation. In *Proceedings of the 17th ACM Conference on Recommender Systems*. 1096–1102.
- [45] Taha Hassan. 2019. Trust and trustworthiness in social recommender systems. In *Companion proceedings of the 2019 world wide web conference*. 529–532.
- [46] Tom Henighan, Jared Kaplan, Mor Katz, Mark Chen, Christopher Hesse, Jacob Jackson, Heewoo Jun, Tom B Brown, Prafulla Dhariwal, Scott Gray, et al. 2020. Scaling laws for autoregressive generative modeling. *arXiv preprint arXiv:2010.14701* (2020).
- [47] Yupeng Hou, Junjie Zhang, Zihan Lin, Hongyu Lu, Ruobing Xie, Julian McAuley, and Wayne Xin Zhao. 2024. Large language models are zero-shot rankers for recommender systems. In *European Conference on Information Retrieval*. Springer, 364–381.
- [48] David M Howcroft, Anya Belz, Miruna Clinciu, Dimitra Gkatzia, Sadid A Hasan, Saad Mahamood, Simon Mille, Emiel Van Miltenburg, Sashank Santhanam, and Verena Rieser. 2020. Twenty years of confusion in human evaluation: NLG needs evaluation sheets and standardised definitions. In *13th International Conference on Natural Language Generation 2020*. Association for Computational Linguistics, 169–182.
- [49] Edward J Hu, Yelong Shen, Phillip Wallis, Zeyuan Allen-Zhu, Yuanzhi Li, Shean Wang, Lu Wang, and Weizhu Chen. 2021. Lora: Low-rank adaptation of large language models. *arXiv preprint arXiv:2106.09685* (2021).
- [50] Wenyue Hua, Shuyuan Xu, Yingqiang Ge, and Yongfeng Zhang. 2023. How to index item ids for recommendation foundation models. In *Proceedings of the Annual International ACM SIGIR Conference on Research and Development in Information Retrieval in the Asia Pacific Region*. 195–204.
- [51] Chengkai Huang, Tong Yu, Kaige Xie, Shuai Zhang, Lina Yao, and Julian McAuley. 2024. Foundation Models for Recommender Systems: A Survey and New Perspectives. *arXiv preprint arXiv:2402.11143* (2024).
- [52] Lei Huang, Weijiang Yu, Weitao Ma, Weihong Zhong, Zhangyin Feng, Haotian Wang, Qianglong Chen, Weihua Peng, Xiaocheng Feng, Bing Qin, et al. 2023. A survey on hallucination in large language models: Principles, taxonomy, challenges, and open questions. *arXiv preprint arXiv:2311.05232* (2023).
- [53] Xu Huang, Jianxun Lian, Yuxuan Lei, Jing Yao, Defu Lian, and Xing Xie. 2023. Recommender ai agent: Integrating large language models for interactive recommendations. *arXiv preprint arXiv:2308.16505* (2023).
- [54] Gautier Izacard, Patrick Lewis, Maria Lomeli, Lucas Hosseini, Fabio Petroni, Timo Schick, Jane Dwivedi-Yu, Armand Joulin, Sebastian Riedel, and Edouard Grave. 2022. Atlas: Few-shot learning with retrieval augmented language models. *arXiv preprint arXiv:2208.03299* (2022).
- [55] Ramtin Jabbari, Nauman bin Ali, Kai Petersen, and Binish Tanveer. 2016. What is DevOps? A systematic mapping study on definitions and practices. In *Proceedings of the scientific workshop proceedings of XP2016*. 1–11.
- [56] Dietmar Jannach, Ahtsham Manzoor, Wanling Cai, and Li Chen. 2021. A survey on conversational recommender systems. *ACM Computing Surveys (CSUR)* 54, 5 (2021), 1–36.
- [57] Ziwei Ji, Nayeon Lee, Rita Frieske, Tiezheng Yu, Dan Su, Yan Xu, Etsuko Ishii, Ye Jin Bang, Andrea Madotto, and Pascale Fung. 2023. Survey of hallucination in natural language generation. *Comput. Surveys* 55, 12 (2023), 1–38.
- [58] Albert Q Jiang, Alexandre Sablayrolles, Arthur Mensch, Chris Bamford, Devendra Singh Chaplot, Diego de las Casas, Florian Bressand, Gianna Lengyel, Guillaume Lample, Lucile Saulnier, et al. 2023. Mistral 7B. *arXiv preprint arXiv:2310.06825* (2023).
- [59] Zhengbao Jiang, Frank F Xu, Luyu Gao, Zhiqing Sun, Qian Liu, Jane Dwivedi-Yu, Yiming Yang, Jamie Callan, and Graham Neubig. 2023. Active Retrieval Augmented Generation. In *Proceedings of the 2023 Conference on Empirical Methods in Natural Language Processing*. 7969–7992.
- [60] Xiaoqi Jiao, Yichun Yin, Lifeng Shang, Xin Jiang, Xiao Chen, Linlin Li, Fang Wang, and Qun Liu. 2019. Tinybert: Distilling bert for natural language understanding. *arXiv preprint arXiv:1909.10351* (2019).
- [61] Thorsten Joachims, Adith Swaminathan, and Tobias Schnabel. 2017. Unbiased learning-to-rank with biased feedback. In *Proceedings of the tenth ACM international conference on web search and data mining*. 781–789.
- [62] Jean Kaddour, Joshua Harris, Maximilian Mozes, Herbie Bradley, Roberta Raileanu, and Robert McHardy. 2023. Challenges and applications of large language models. *arXiv preprint arXiv:2307.10169* (2023).
- [63] Jared Kaplan, Sam McCandlish, Tom Henighan, Tom B Brown, Benjamin Chess, Rewon Child, Scott Gray, Alec Radford, Jeffrey Wu, and Dario Amodei. 2020. Scaling laws for neural language models. *arXiv preprint arXiv:2001.08361* (2020).
- [64] Vladimir Karpukhin, Barlas Oguz, Sewon Min, Patrick Lewis, Ledell Wu, Sergey Edunov, Danqi Chen, and Wen-tau Yih. 2020. Dense passage retrieval for open-domain question answering. *arXiv preprint arXiv:2004.04906* (2020).
- [65] Zachary Kenton, Tom Everitt, Laura Weidinger, Iason Gabriel, Vladimir Mikulik, and Geoffrey Irving. 2021. Alignment of language agents. *arXiv preprint arXiv:2103.14659* (2021).
- [66] Barrie Kersbergen and Sebastian Schelter. 2021. Learnings from a Retail Recommendation System on Billions of Interactions at bol. com. In *2021 IEEE 37th International Conference on Data Engineering (ICDE)*. IEEE, 2447–2452.
- [67] Hyeoung Ko, Suyeon Lee, Yoonseo Park, and Anna Choi. 2022. A survey of recommendation systems: recommendation models, techniques, and application fields. *Electronics* 11, 1 (2022), 141.
- [68] Ron Kohavi, Randal M Henne, and Dan Sommerfield. 2007. Practical guide to controlled experiments on the web: listen to your customers not to the hippo. In *Proceedings of the 13th ACM SIGKDD international conference on Knowledge discovery and data mining*. 959–967.
- [69] Ron Kohavi, Diane Tang, and Ya Xu. 2020. *Trustworthy online controlled experiments: A practical guide to a/b testing*. Cambridge University Press.
- [70] Dominik Kreuzberger, Niklas Kühl, and Sebastian Hirschl. 2023. Machine learning operations (mlops): Overview, definition, and architecture. *IEEE access* (2023).
- [71] Woosuk Kwon, Zhuohan Li, Siyuan Zhuang, Ying Sheng, Lianmin Zheng, Cody Hao Yu, Joseph Gonzalez, Hao Zhang, and Ion Stoica. 2023. Efficient memory management for large language model serving with pagedattention. In *Proceedings of the 29th Symposium on Operating Systems Principles*. 611–626.
- [72] Patrick Lewis, Ethan Perez, Aleksandra Piktus, Fabio Petroni, Vladimir Karpukhin, Naman Goyal, Heinrich Küttler, Mike Lewis, Wen-tau Yih, Tim Rocktäschel, et al. 2020. Retrieval-augmented generation for knowledge-intensive nlp tasks. *Advances in Neural Information Processing Systems* 33 (2020), 9459–9474.
- [73] Chen Li, Yixiao Ge, Jiayong Mao, Dian Li, and Ying Shan. 2023. Taggpt: Large language models are zero-shot multimodal taggers. *arXiv preprint arXiv:2304.03022* (2023).
- [74] Huayang Li, Yixuan Su, Deng Cai, Yan Wang, and Lemao Liu. 2022. A survey on retrieval-augmented text generation. *arXiv preprint arXiv:2202.01110* (2022).
- [75] Jiacheng Li, Ming Wang, Jin Li, Jimmiao Fu, Xin Shen, Jingbo Shang, and Julian McAuley. 2023. Text is all you need: Learning language representations for sequential recommendation. In *Proceedings of the 29th ACM SIGKDD Conference on Knowledge Discovery and Data Mining*. 1258–1267.
- [76] Lihong Li, Wei Chu, John Langford, and Robert E Schapire. 2010. A contextual-bandit approach to personalized news article recommendation. In *Proceedings of the 19th international conference on World wide web*. 661–670.
- [77] Lei Li, Yongfeng Zhang, and Li Chen. 2020. Generate neural template explanations for recommendation. In *Proceedings of the 29th ACM International Conference on Information & Knowledge Management*. 755–764.
- [78] Xiaonan Li, Changtai Zhu, Linyang Li, Zhangyue Yin, Tianxiang Sun, and Xipeng Qiu. 2023. Llretrieval: Llm-verified retrieval for verifiable generation. *arXiv preprint arXiv:2311.07838* (2023).
- [79] Xiang Lisa Li and Percy Liang. 2021. Prefix-tuning: Optimizing continuous prompts for generation. *arXiv preprint arXiv:2101.00190* (2021).
- [80] Percy Liang, Rishi Bommasani, Tony Lee, Dimitris Tsipras, Dilara Soylu, Michihiro Yasunaga, Yian Zhang, Deepak Narayanan, Yuhuai Wu, Ananya Kumar, et al. 2022. Holistic evaluation of language models. *arXiv preprint arXiv:2211.09110* (2022).
- [81] Jianghao Lin, Xinyi Dai, Yunjia Xi, Weiwen Liu, Bo Chen, Xiangyang Li, Chenxu Zhu, Huifeng Guo, Yong Yu, Ruiming Tang, et al. 2023. How can recommender systems benefit from large language models: A survey. *arXiv preprint arXiv:2306.05817* (2023).
- [82] Jianghao Lin, Rong Shan, Chenxu Zhu, Kounianhua Du, Bo Chen, Shigang Quan, Ruiming Tang, Yong Yu, and Weinan Zhang. 2023. Rella: Retrieval-enhanced large language models for lifelong sequential behavior comprehension in recommendation. *arXiv preprint arXiv:2308.11131* (2023).
- [83] Stephanie Lin, Jacob Hilton, and Owain Evans. 2021. Truthfulqa: Measuring how models mimic human falsehoods. *arXiv preprint arXiv:2109.07958* (2021).
- [84] Pengfei Liu, Weizhe Yuan, Jinlan Fu, Zhengbao Jiang, Hiroaki Hayashi, and Graham Neubig. 2023. Pre-train, prompt, and predict: A systematic survey of prompting methods in natural language processing. *Comput. Surveys* 55, 9 (2023), 1–35.
- [85] Tie-Yan Liu et al. 2009. Learning to rank for information retrieval. *Foundations and Trends® in Information Retrieval* 3, 3 (2009), 225–331.

- [86] Xiao Liu, Kaixuan Ji, Yicheng Fu, Weng Lam Tam, Zhengxiao Du, Zhilin Yang, and Jie Tang. 2021. P-tuning v2: Prompt tuning can be comparable to fine-tuning universally across scales and tasks. *arXiv preprint arXiv:2110.07602* (2021).
- [87] Yao Lu, Max Bartolo, Alastair Moore, Sebastian Riedel, and Pontus Stenetorp. 2021. Fantastically ordered prompts and where to find them: Overcoming few-shot prompt order sensitivity. *arXiv preprint arXiv:2104.08786* (2021).
- [88] Xinbei Ma, Yeyun Gong, Pengcheng He, Hai Zhao, and Nan Duan. 2023. Query Rewriting in Retrieval-Augmented Large Language Models. In *Proceedings of the 2023 Conference on Empirical Methods in Natural Language Processing*, 5303–5315.
- [89] Marjan Mernik, Jan Heering, and Anthony M Sloane. 2005. When and how to develop domain-specific languages. *ACM computing surveys (CSUR)* 37, 4 (2005), 316–344.
- [90] Xupeng Miao, Gabriele Oliaro, Zhihao Zhang, Xinhao Cheng, Hongyi Jin, Tianqi Chen, and Zhihao Jia. 2023. Towards efficient generative large language model serving: A survey from algorithms to systems. *arXiv preprint arXiv:2312.15234* (2023).
- [91] Sewon Min, Xinxu Lyu, Ari Holtzman, Mikel Artetxe, Mike Lewis, Hannaneh Hajishirzi, and Luke Zettlemoyer. 2022. Rethinking the role of demonstrations: What makes in-context learning work? *arXiv preprint arXiv:2202.12837* (2022).
- [92] Maxim Naumov, Dheevatsa Mudigere, Hao-Jun Michael Shi, Jianyu Huang, Narayanan Sundaraman, Jongsoo Park, Xiaodong Wang, Udit Gupta, Carole-Jean Wu, Alisson G Azzolini, et al. 2019. Deep learning recommendation model for personalization and recommendation systems. *arXiv preprint arXiv:1906.00091* (2019).
- [93] Mehrbakhsh Nilashi, Dietmar Jannach, Othman bin Ibrahim, Mohammad Dalvi Esfahani, and Hossein Ahmadi. 2016. Recommendation quality, transparency, and website quality for trust-building in recommendation agents. *Electronic Commerce Research and Applications* 19 (2016), 70–84.
- [94] Wei Niu, Jiexiong Guan, Yanzhi Wang, Gagan Agrawal, and Bin Ren. 2021. DNN-Fusion: accelerating deep neural networks execution with advanced operator fusion. In *Proceedings of the 42nd ACM SIGPLAN International Conference on Programming Language Design and Implementation*. 883–898.
- [95] OpenAI. 2023. Chat gpt 4 painfully slow. <https://community.openai.com/t/chat-gpt-4-painfully-slow/117996>. (2023).
- [96] Long Ouyang, Jeffrey Wu, Xu Jiang, Diogo Almeida, Carroll Wainwright, Pamela Mishkin, Chong Zhang, Sandhini Agarwal, Katarina Slama, Alex Ray, et al. 2022. Training language models to follow instructions with human feedback. *Advances in neural information processing systems* 35 (2022), 27730–27744.
- [97] Alicia Parrish, Angelica Chen, Nikita Nangia, Vishakh Padmakumar, Jason Phang, Jana Thompson, Phu Mon Htut, and Samuel R Bowman. 2021. BQ: A hand-built bias benchmark for question answering. *arXiv preprint arXiv:2110.08193* (2021).
- [98] Ethan Perez, Saffron Huang, Francis Song, Trevor Cai, Roman Ring, John Aslanides, Amelia Glaese, Nat McAleese, and Geoffrey Irving. 2022. Red teaming language models with language models. *arXiv preprint arXiv:2202.03286* (2022).
- [99] Saverio Perugini and Marcos André Gonçalves. 2002. Recommendation and personalization: a survey. *Journal of Intelligent Information Systems* (2002).
- [100] Fabio Petroni, Tim Rocktäschel, Patrick Lewis, Anton Bakhtin, Yuxiang Wu, Alexander H Miller, and Sebastian Riedel. 2019. Language models as knowledge bases? *arXiv preprint arXiv:1909.01066* (2019).
- [101] et al Pleiss, Geoff. 2020. Identifying mislabeled data using the area under the margin ranking. *Advances in Neural Information Processing Systems* 33 (2020).
- [102] Reiner Pope, Sholto Douglas, Aakanksha Chowdhery, Jacob Devlin, James Bradbury, Jonathan Heek, Kefan Xiao, Shivani Agrawal, and Jeff Dean. 2023. Efficiently scaling transformer inference. *Proceedings of Machine Learning and Systems* 5 (2023).
- [103] Alec Radford, Jong Wook Kim, Chris Hallacy, Aditya Ramesh, Gabriel Goh, Sandhini Agarwal, Girish Sastry, Amanda Askell, Pamela Mishkin, Jack Clark, et al. 2021. Learning transferable visual models from natural language supervision. In *International conference on machine learning*. PMLR, 8748–8763.
- [104] Rafael Rafailov, Archit Sharma, Eric Mitchell, Christopher D Manning, Stefano Ermon, and Chelsea Finn. 2024. Direct preference optimization: Your language model is secretly a reward model. *Advances in Neural Information Processing Systems* 36 (2024).
- [105] Colin Raffel, Noam Shazeer, Adam Roberts, Katherine Lee, Sharan Narang, Michael Matena, Yanqi Zhou, Wei Li, and Peter J Liu. 2020. Exploring the limits of transfer learning with a unified text-to-text transformer. *Journal of machine learning research* 21, 140 (2020), 1–67.
- [106] Shashank Rajput, Nikhil Mehta, Anima Singh, Raghunandan Hulikal Keshavan, Trung Vu, Lukas Heldt, Lichan Hong, Yi Tay, Vinh Tran, Jonah Samost, et al. 2024. Recommender systems with generative retrieval. *Advances in Neural Information Processing Systems* 36 (2024).
- [107] Vipula Rawte, Amit Sheth, and Amitava Das. 2023. A survey of hallucination in large foundation models. *arXiv preprint arXiv:2309.05922* (2023).
- [108] Xubin Ren, Wei Wei, Lianghao Xia, Lixin Su, Suqi Cheng, Junfeng Wang, Dawei Yin, and Chao Huang. 2023. Representation learning with large language models for recommendation. *arXiv preprint arXiv:2310.15950* (2023).
- [109] Francesco Ricci, Lior Rokach, and Bracha Shapira. 2010. Introduction to recommender systems handbook. In *Recommender systems handbook*. Springer, 1–35.
- [110] Robin Rombach, Andreas Blattmann, Dominik Lorenz, Patrick Esser, and Björn Ommer. 2022. High-resolution image synthesis with latent diffusion models. In *Proceedings of the IEEE/CVF conference on computer vision and pattern recognition*. 10684–10695.
- [111] Ananya B Sai, Akash Kumar Mohankumar, and Mitesh M Khapra. 2022. A survey of evaluation metrics used for NLG systems. *ACM Computing Surveys (CSUR)* 55, 2 (2022), 1–39.
- [112] Rohan Sarkar, Navaneeth Bodla, Mariya I Vasileva, Yen-Liang Lin, Anurag Beniwal, Alan Lu, and Gerard Medioni. 2023. Outfittransformer: Learning outfit representations for fashion recommendation. In *Proceedings of the IEEE/CVF Winter Conference on Applications of Computer Vision*. 3601–3609.
- [113] Timo Schick, Jane Dwivedi-Yu, Roberto Dessi, Roberta Raileanu, Maria Lomeli, Eric Hambro, Luke Zettlemoyer, Nicola Cancedda, and Thomas Scialom. 2024. Toolformer: Language models can teach themselves to use tools. *Advances in Neural Information Processing Systems* 36 (2024).
- [114] Timo Schick and Hinrich Schütze. 2020. It's not just size that matters: Small language models are also few-shot learners. *arXiv preprint arXiv:2009.07118* (2020).
- [115] Timo Schick, Sahana Udupa, and Hinrich Schütze. 2021. Self-diagnosis and self-debiasing: A proposal for reducing corpus-based bias in nlp. *Transactions of the Association for Computational Linguistics* 9 (2021), 1408–1424.
- [116] Aarohi Srivastava, Abhinav Rastogi, Abhishek Rao, Abu Awal Md Shoeb, Abubakar Abid, Adam Fisch, Adam R Brown, Adam Santoro, Aditya Gupta, Adria Garriga-Alonso, et al. 2022. Beyond the imitation game: Quantifying and extrapolating the capabilities of language models. *arXiv preprint arXiv:2206.04615* (2022).
- [117] Weiwei Sun, Lingyong Yan, Zheng Chen, Shuaiqiang Wang, Haichao Zhu, Pengjie Ren, Zhumin Chen, Dawei Yin, Maarten Rijke, and Zhaochun Ren. 2024. Learning to tokenize for generative retrieval. *Advances in Neural Information Processing Systems* 36 (2024).
- [118] Jiliang Tang, Xia Hu, and Huan Liu. 2013. Social recommendation: a review. *Social Network Analysis and Mining* 3 (2013), 1113–1133.
- [119] Alexander Tarvo, Peter F Sweeney, Nick Mitchell, VT Rajan, Matthew Arnold, and Ioana Baldini. 2015. CanaryAdvisor: a statistical-based tool for canary testing. In *Proceedings of the 2015 International Symposium on Software Testing and Analysis*. 418–422.
- [120] SM Tonmoy, SM Zaman, Vinija Jain, Anku Rani, Vipula Rawte, Aman Chadha, and Amitava Das. 2024. A comprehensive survey of hallucination mitigation techniques in large language models. *arXiv preprint arXiv:2401.01313* (2024).
- [121] Hugo Touvron, Thibaut Lavril, Gautier Izacard, Xavier Martinet, Marie-Anne Lachaux, Timothée Lacroix, Baptiste Rozière, Naman Goyal, Eric Hambro, Faisal Azhar, et al. 2023. Llama: Open and efficient foundation language models. *arXiv preprint arXiv:2302.13971* (2023).
- [122] Boxin Wang, Weixin Chen, Hengzhi Pei, Chulin Xie, Mintong Kang, Chenhui Zhang, Chejian Xu, Zidi Xiong, Ritik Dutta, Rylan Schaeffer, et al. 2023. Decodingtrust: A comprehensive assessment of trustworthiness in gpt models. *arXiv preprint arXiv:2306.11698* (2023).
- [123] Lei Wang, Chen Ma, Xueyang Feng, Zeyu Zhang, Hao Yang, Jingsen Zhang, Zhiyuan Chen, Jiakai Tang, Xu Chen, Yankai Lin, et al. 2023. A survey on large language model based autonomous agents. *arXiv preprint arXiv:2308.11432* (2023).
- [124] Lei Wang, Jingsen Zhang, Xu Chen, Yankai Lin, Ruihua Song, Wayne Xin Zhao, and Ji-Rong Wen. 2023. Recagent: A novel simulation paradigm for recommender systems. *arXiv preprint arXiv:2306.02552* (2023).
- [125] Shoujin Wang, Xiuzhen Zhang, Yan Wang, and Francesco Ricci. 2022. Trustworthy recommender systems. *ACM Transactions on Intelligent Systems and Technology* (2022).
- [126] Wenjie Wang, Xinyu Lin, Fuli Feng, Xiangnan He, and Tat-Seng Chua. 2023. Generative recommendation: Towards next-generation recommender paradigm. *arXiv preprint arXiv:2304.03516* (2023).
- [127] Xuezhi Wang, Jason Wei, Dale Schuurmans, Quoc Le, Ed Chi, Sharan Narang, Aakanksha Chowdhery, and Denny Zhou. 2022. Self-consistency improves chain of thought reasoning in language models. *arXiv preprint arXiv:2203.11171* (2022).
- [128] Yan Wang, Zhixuan Chu, Xin Ouyang, Simeng Wang, Hongyan Hao, Yue Shen, Jinjie Gu, Siqiao Xue, James Y Zhang, Qing Cui, et al. 2023. Enhancing recommender systems with large language model reasoning graphs. *arXiv preprint arXiv:2308.10835* (2023).
- [129] Yancheng Wang, Ziyang Jiang, Zheng Chen, Fan Yang, Yingxue Zhou, Eunah Cho, Xing Fan, Xiaojiang Huang, Yanbin Lu, and Yingzhen Yang. 2023. Recmind: Large language model powered agent for recommendation. *arXiv preprint arXiv:2308.14296* (2023).
- [130] Alexander Wei, Nika Haghtalab, and Jacob Steinhardt. 2024. Jailbroken: How does llm safety training fail? *Advances in Neural Information Processing Systems* 36 (2024).

- [131] Jason Wei, Xuezhi Wang, Dale Schuurmans, Maarten Bosma, Fei Xia, Ed Chi, Quoc V Le, Denny Zhou, et al. 2022. Chain-of-thought prompting elicits reasoning in large language models. *Advances in neural information processing systems* 35 (2022), 24824–24837.
- [132] Kangning Wei, Jinghua Huang, and Shaohong Fu. 2007. A survey of e-commerce recommender systems. In *2007 international conference on service systems and service management*. IEEE, 1–5.
- [133] Wei Wei, Xubin Ren, Jiabin Tang, Qinyong Wang, Lixin Su, Suqi Cheng, Junfeng Wang, Dawei Yin, and Chao Huang. 2024. Llmrec: Large language models with graph augmentation for recommendation. In *Proceedings of the 17th ACM International Conference on Web Search and Data Mining*, 806–815.
- [134] Justin D Weisz, Jessica He, Michael Muller, Gabriela Hoefler, Rachel Miles, and Werner Geyer. 2024. Design Principles for Generative AI Applications. *arXiv preprint arXiv:2401.14484* (2024).
- [135] Johannes Welbl, Amelia Glaese, Jonathan Uesato, Sumanth Dathathri, John Mellor, Lisa Anne Hendricks, Kirsty Anderson, Pushmeet Kohli, Ben Coppin, and Po-Sen Huang. 2021. Challenges in detoxifying language models. *arXiv preprint arXiv:2109.07445* (2021).
- [136] ChengHo Wu, Chih-Yu Chou, and Hsin Pang Tsai. 2023. A Framework for PromptOps in GenAI Application Development Lifecycle. (2023).
- [137] Jiahao Wu, Qijiong Liu, Hengchang Hu, Wenqi Fan, Shengcai Liu, Qing Li, Xiao-Ming Wu, and Ke Tang. 2023. Leveraging Large Language Models (LLMs) to Empower Training-Free Dataset Condensation for Content-Based Recommendation. *arXiv preprint arXiv:2310.09874* (2023).
- [138] Likang Wu, Zhi Zheng, Zhaopeng Qiu, Hao Wang, Hongchao Gu, Tingjia Shen, Chuan Qin, Chen Zhu, Hengshu Zhu, Qi Liu, et al. 2023. A survey on large language models for recommendation. *arXiv preprint arXiv:2305.19860* (2023).
- [139] Yunjia Xi, Weiwen Liu, Jianghao Lin, Jieming Zhu, Bo Chen, Ruiming Tang, Weinan Zhang, Rui Zhang, and Yong Yu. 2023. Towards open-world recommendation with knowledge augmentation from large language models. *arXiv preprint arXiv:2306.10933* (2023).
- [140] Zhiheng Xi, Wenxiang Chen, Xin Guo, Wei He, Yiwen Ding, Boyang Hong, Ming Zhang, Junzhe Wang, Senjie Jin, Enyu Zhou, et al. 2023. The rise and potential of large language model based agents: A survey. *arXiv preprint arXiv:2309.07864* (2023).
- [141] Han Xie, Da Zheng, Jun Ma, Houyu Zhang, Vassilis N Ioannidis, Xiang Song, Qing Ping, Sheng Wang, Carl Yang, Yi Xu, et al. 2023. Graph-aware language model pre-training on a large graph corpus can help multiple graph applications. In *Proceedings of the 29th ACM SIGKDD Conference on Knowledge Discovery and Data Mining*. 5270–5281.
- [142] Shuyuan Xu, Wenyue Hua, and Yongfeng Zhang. 2023. Openp5: Benchmarking foundation models for recommendation. *arXiv preprint arXiv:2306.11134* (2023).
- [143] Shi-Qi Yan, Jia-Chen Gu, Yun Zhu, and Zhen-Hua Ling. 2024. Corrective Retrieval Augmented Generation. *arXiv preprint arXiv:2401.15884* (2024).
- [144] Jingfeng Yang, Haoming Jiang, Qingyu Yin, Danqing Zhang, Bing Yin, and Diyi Yang. 2022. SEQZERO: Few-shot Compositional Semantic Parsing with Sequential Prompts and Zero-shot Models. In *Findings of the Association for Computational Linguistics: NAACL 2022*. 49–60.
- [145] Rui Yang, Lin Song, Yanwei Li, Sijie Zhao, Yixiao Ge, Xiu Li, and Ying Shan. 2024. Gpt4tools: Teaching large language model to use tools via self-instruction. *Advances in Neural Information Processing Systems* 36 (2024).
- [146] Zhengyuan Yang, Linjie Li, Kevin Lin, Jianfeng Wang, Chung-Ching Lin, Zicheng Liu, and Lijuan Wang. 2023. The dawn of llms: Preliminary explorations with gpt-4v (ision). *arXiv preprint arXiv:2309.17421* 9, 1 (2023), 1.
- [147] Shunyu Yao, Dian Yu, Jeffrey Zhao, Izhak Shafran, Tom Griffiths, Yuan Cao, and Karthik Narasimhan. 2024. Tree of thoughts: Deliberate problem solving with large language models. *Advances in Neural Information Processing Systems* 36 (2024).
- [148] Shunyu Yao, Jeffrey Zhao, Dian Yu, Nan Du, Izhak Shafran, Karthik Narasimhan, and Yuan Cao. 2022. React: Synergizing reasoning and acting in language models. *arXiv preprint arXiv:2210.03629* (2022).
- [149] Bin Yin, Junjie Xie, Yu Qin, Zixiang Ding, Zhichao Feng, Xiang Li, and Wei Lin. 2023. Heterogeneous knowledge fusion: A novel approach for personalized recommendation via llm. In *Proceedings of the 17th ACM Conference on Recommender Systems*. 599–601.
- [150] Rex Ying, Ruining He, Kaifeng Chen, Pong Eksombatchai, William L Hamilton, and Jure Leskovec. 2018. Graph convolutional neural networks for web-scale recommender systems. In *Proceedings of the 24th ACM SIGKDD international conference on knowledge discovery & data mining*. 974–983.
- [151] Zheng Yuan, Fajie Yuan, Yu Song, Youhua Li, Junchen Fu, Fei Yang, Yunzhu Pan, and Yongxin Ni. 2023. Where to go next for recommender systems? id-vs. modality-based recommender models revisited. In *Proceedings of the 46th International ACM SIGIR Conference on Research and Development in Information Retrieval*. 2639–2649.
- [152] Ofir Zafrir, Guy Boudoukh, Peter Izsak, and Moshe Wasserblat. 2019. Q8bert: Quantized 8bit bert. In *2019 Fifth Workshop on Energy Efficient Machine Learning and Cognitive Computing-NeurIPS Edition (EMC2-NIPS)*. IEEE, 36–39.
- [153] An Zhang, Leheng Sheng, Yuxin Chen, Hao Li, Yang Deng, Xiang Wang, and Tat-Seng Chua. 2023. On generative agents in recommendation. *arXiv preprint arXiv:2310.10108* (2023).
- [154] Jizhi Zhang, Keqin Bao, Yang Zhang, Wenjie Wang, Fuli Feng, and Xiangnan He. 2023. Is chatgpt fair for recommendation? evaluating fairness in large language model recommendation. In *Proceedings of the 17th ACM Conference on Recommender Systems*. 993–999.
- [155] Junjie Zhang, Yupeng Hou, Ruobing Xie, Wenqi Sun, Julian McAuley, Wayne Xin Zhao, Leyu Lin, and Ji-Rong Wen. 2023. Agentf: Collaborative learning with autonomous language agents for recommender systems. *arXiv preprint arXiv:2310.09233* (2023).
- [156] Shuai Zhang, Lina Yao, Aixin Sun, and Yi Tay. 2019. Deep learning based recommender system: A survey and new perspectives. *ACM computing surveys (CSUR)* 52, 1 (2019), 1–38.
- [157] Yue Zhang, Yafu Li, Leyang Cui, Deng Cai, Lemaou Liu, Tingchen Fu, Xinting Huang, Enbo Zhao, Yu Zhang, Yulong Chen, et al. 2023. Siren’s song in the AI ocean: a survey on hallucination in large language models. *arXiv preprint arXiv:2309.01219* (2023).
- [158] Zihao Zhao, Eric Wallace, Shi Feng, Dan Klein, and Sameer Singh. 2021. Calibrate before use: Improving few-shot performance of language models. In *International conference on machine learning*. PMLR, 12697–12706.
- [159] Kaitlyn Zhou, Su Lin Blodgett, Adam Trischler, Hal Daumé III, Kaheer Suleman, and Alexandra Olteanu. 2022. Deconstructing NLG evaluation: Evaluation practices, assumptions, and their implications. *arXiv preprint arXiv:2205.06828* (2022).
- [160] Yaochen Zhu, Liang Wu, Qi Guo, Liangjie Hong, and Jundong Li. 2023. Collaborative large language model for recommender systems. *arXiv preprint arXiv:2311.01343* (2023).
- [161] Shengyao Zhuang, Bing Liu, Bevan Koopman, and Guido Zuccon. 2023. Open-source Large Language Models are Strong Zero-shot Query Likelihood Models for Document Ranking. In *Findings of the Association for Computational Linguistics: EMNLP 2023*. 8807–8817.
- [162] Terry Yue Zhuo, Yujin Huang, Chunyang Chen, and Zhenchang Xing. 2023. Red teaming chatgpt via jailbreaking: Bias, robustness, reliability and toxicity. *arXiv preprint arXiv:2301.12867* (2023).
- [163] Andy Zou, Zifan Wang, J Zico Kolter, and Matt Fredrikson. 2023. Universal and transferable adversarial attacks on aligned language models. *arXiv preprint arXiv:2307.15043* (2023).