

FineWAVE: Fine-Grained Warning Verification of Bugs for Automated Static Analysis Tools

HAN LIU, East China Normal University, China

JIAN ZHANG, Nanyang Technological University, Singapore

CEN ZHANG, Nanyang Technological University, Singapore

XIAOHAN ZHANG, Xidian University, China

KAIXUAN LI, East China Normal University, China

SEN CHEN, Tianjin University, China

SHANG-WEI LIN, Nanyang Technological University, Singapore

YIXIANG CHEN, East China Normal University, China

XINGHUA LI, Xidian University, China

YANG LIU, Nanyang Technological University, Singapore

Automated Static Analysis Tools (ASATs) have evolved over time to assist in detecting bugs. However, the excessive false warnings can impede developers' productivity and confidence in the tools. Previous research efforts have explored learning-based methods to validate the reported warnings. Nevertheless, their coarse granularity, focusing on either long-term warnings or function-level alerts, which are insensitive to individual bugs. Also, they rely on manually crafted features or solely on source code semantics, which is inadequate for effective learning.

In this paper, we propose FineWAVE, a learning-based approach that verifies bug-sensitive warnings at a fine-grained granularity. Specifically, we design a novel LSTM-based model that captures multi-modal semantics of source code and warnings from ASATs and highlights their correlations with cross-attention. To tackle the data scarcity of training and evaluation, we collected a large-scale dataset of 280,273 warnings. We conducted extensive experiments on the dataset to evaluate FineWAVE. The experimental results demonstrate the effectiveness of our approach, with an F1-score of 97.79% for reducing false alarms and 67.06% for confirming actual warnings, significantly outperforming all baselines. Moreover, we have applied our FineWAVE to filter out about 92% warnings in four popular real-world projects, and found 25 new bugs with minimal manual effort.

CCS Concepts: • **Software and its engineering** → **Software maintenance tools**; • **General and reference** → **Reliability**.

Additional Key Words and Phrases: static analysis tools, warnings verification, bug-sensitive warnings

Authors' addresses: Han Liu, East China Normal University, Shanghai, China, hanliu@stu.ecnu.edu.cn; Jian Zhang, Nanyang Technological University, Singapore, Singapore, jian_zhang@ntu.edu.sg; Cen Zhang, Nanyang Technological University, Singapore, Singapore, cen001@e.ntu.edu.sg; Xiaohan Zhang, Xidian University, Xi'an, China, zhangxh@stu.xidian.edu.cn; Kaixuan Li, East China Normal University, Shanghai, China, kaixuanli@stu.ecnu.edu.cn; Sen Chen, Tianjin University, Tianjin, China, senchen@tju.edu.cn; Shang-wei Lin, Nanyang Technological University, Singapore, Singapore, shang-wei.lin@ntu.edu.sg; Yixiang Chen, East China Normal University, Shanghai, China, yxchen@sei.ecnu.edu.cn; Xinghua Li, Xidian University, Xi'an, China, xhli1@mail.xidian.edu.cn; Yang Liu, Nanyang Technological University, Singapore, Singapore, yangliu@ntu.edu.sg.

Permission to make digital or hard copies of all or part of this work for personal or classroom use is granted without fee provided that copies are not made or distributed for profit or commercial advantage and that copies bear this notice and the full citation on the first page. Copyrights for components of this work owned by others than ACM must be honored. Abstracting with credit is permitted. To copy otherwise, or republish, to post on servers or to redistribute to lists, requires prior specific permission and/or a fee. Request permissions from permissions@acm.org.

© 2018 Association for Computing Machinery.

Manuscript submitted to ACM

Manuscript submitted to ACM

1

ACM Reference Format:

Han Liu, Jian Zhang, Cen Zhang, Xiaohan Zhang, Kaixuan Li, Sen Chen, Shang-wei Lin, Yixiang Chen, Xinghua Li, and Yang Liu. 2018. FineWAVE: Fine-Grained Warning Verification of Bugs for Automated Static Analysis Tools. 1, 1 (April 2018), 22 pages. <https://doi.org/XXXXXXXX.XXXXXXX>

1 INTRODUCTION

In the rapidly evolving software landscape, where complexity continues to grow, the eradication of bugs has become a paramount concern for developers. Numerous methodologies have been adopted to address this issue, including fuzzy testing [6, 64, 69], deep learning [5, 41, 70], and static analysis [2, 11, 14, 60]. Among them, static analysis has emerged as the preferred technique for a significant proportion of developers. As such, automated static analysis tools (ASATs) have become an instrumental resource for bug detection. However, they suffer from an inherent drawback - in their manually defined rules/patterns for uncovering bugs, they often generate excessive warnings. This situation presents a significant challenge for developers as they are burdened with the task of identifying real issues from a large number of reported alerts. In reality, recent research reveals that nearly 90% of these warnings may be false positives [27], implying that a substantial volume of these alerts might not contribute to the detection of actual bugs [19].

To address the problem, existing studies have proposed approaches for reducing false positives of ASATs. Earlier research primarily focuses on identifying actionable warnings that are likely to disappear over a long development process (i.e., 3–6 months), with the aim to filter out the false positives [20, 22, 23, 32, 50, 61, 62, 65, 67]. This approach typically adopts a machine learning-based classifier and requires manually extracted features of ASAT-generated warnings, source code [20], historical data [61, 62], and file attributes [67]. For instance, Wang et al. summarized a set of 23 critical attributes, dubbed as “Golden Features”, which proved effective in recognizing actionable warnings with an AUC score up to 95% [61]. However, as Kang et al. pointed out, there exist issues like data leakage and duplication that severely undermine the reliable identification of truly actionable warnings [27]. On the contrary, Kharkar et al. introduced an alternative approach from the perspective of bug prediction. They employed a transformer-based deep learning model to mitigate false positive warnings by predicting whether there are bugs given the source code of an entire function [28]. This approach demonstrated potential in improving the precision of static analysis tools, with a notable 17.5% increase.

Unfortunately, despite the progress made, several limitations persist in existing work. (**L1: Granularity**) The use of function-level bug prediction for filtering warnings suffers from a coarse granularity, which could lead to mislabeling critical warnings. In practice, a single function may have multiple warnings, consisting of both true and false positives. Consequently, attempting to predict a single label for all these warnings (regardless of whether they are buggy or not) is not a quite feasible solution. Furthermore, even when the model successfully detects a bug, developers would still need to invest significant effort to locate the true warning related to the bug within the function. For identifying actionable warnings, it is simply dependent on the long development history which involves various functional commits (e.g., refactoring, and function alteration). As a result, they may not reflect the remediation of bugs and thus have limited effectiveness for improving ASATs. (**L2: Semantics**) The previous work fails to capture semantics from code and warnings adequately. Kharkar et al.’s approach totally ignores warning messages [28], let alone considering the alignment between code semantics and warning semantics. Feature-based methods require the manual gathering of what is referred to as “golden features”. However, these features may still overlook significant semantic elements, e.g., warnings and interactions within the code. The inadequate semantics may lead to a performance bottleneck for recognizing true or false positives. (**L3: Scale**) Existing studies only evaluate the proposed approaches on a small

number of selected projects. It remains unknown whether these approaches can effectively generalize to a diverse range of projects at a large scale.

In this paper, we proposed a Fine-grained Warning Verification approach, FineWAVE, for verifying warnings at a fine granularity which we call *bug-sensitive warnings*. More formally, a bug-sensitive warning is one individual warning from ASATs that appears in the buggy version but disappears right after its corresponding fixed version. These warnings are fine-grained because they are not only derived from bug-fixing commits, but also are treated separately instead of as a group for one function. Additionally, the line number information and possible symptoms from warnings, allow us to more easily locate the verified bugs. However, automatically verifying fine-grained warnings poses challenges due to both the scarcity of the training data and the complexities of semantics involved.

(C1: Dataset) Currently, only a small number of datasets containing actionable or function-level warnings exist, none of which are suitable for the task at hand. To bridge the gap, we constructed a large-scale dataset of bug-sensitive warnings from 32.1k real-world projects on GitHub, namely BSWarnings. Following previous studies [27, 61, 62], we also specifically focus on SpotBugs, which is a successor of the popular ASAT FindBugs. We collected 607,259 bug-fixing commits through keyword filtering following [21]. Then we used SpotBugs to scan both the buggy and fixed versions of these commits. As defined, we obtained bug-sensitive warnings by comparing the differences in the scan results of the two versions. In total, BSWarnings contains 280,273 warnings, of which 20,100 are bug-sensitive warnings. It is the largest of its kind, being ten times larger than the existing ones. The collection process involved a considerable effort, comprising 1,214,518 compilation and scanning tasks, which spanned over 5,000 consecutive hours on three servers to complete.

(C2: Multi-modal Semantics) The complex nature of bugs and the variety of warnings need careful design to capture their semantics and correlations in multi-modality (i.e., source code of one function, attributes, and natural language of one warning). To tackle it, FineWAVE uses a multi-faceted representation that combines code context encoding, warning information encoding, and a cross-attention mechanism to distinguish between bug-sensitive warnings and bug-insensitive warnings.

Specifically, FineWAVE first parses the input class code and warning message, extracting relevant functions within the class code. Then, two Long Short-Term Memory (LSTM) networks are employed to encode the function code and warning message. To capture the correlations, we design a cross-attention mechanism between function code and warning messages. It enables the model to focus on the most relevant parts and learn the complex relationships between them. On top of that, it is also essential to gather both sufficient and precise context to accurately verify the warnings associated with the functions. At the code level, we introduce warning-aware slicing that can exclude the noise caused by unrelated statements or arbitrary naming. We perform intra-procedure forward and backward slicing on the extracted functions based on the lines that trigger the warning, considering both control and data flow. As an added benefit, this process converts the code to the Jimple representation, a typed 3-address intermediate representation (IR) which provides a more standardized and simplified view of observing program behavior. From a broader perspective, the fields within a class may contain additional context (e.g., the definition of a class variable), which can further aid the model in understanding the function. Hence, we take the slices and fields into consideration by applying LSTMs on them. At the warning level, we extract and encode the information of the warning to the vector, including the message and attributes (i.e., rule, category, rank, and confidence features), which are necessary for warning verification. Finally, we concatenate all the context vectors with feature vectors of warning attributes and classify them as bug-sensitive or bug-insensitive warnings. By pinpointing bug-sensitive warnings and distinguishing them from bug-insensitive ones, developers can prioritize their efforts and efficiently address potential issues in the code.

We conducted extensive experiments on BSWarnings to evaluate our approach. The results indicate that FineWAVE is highly effective in dealing with false alarms, filtering out as much as 98.51% of those warnings with an impressive precision rate of 97.08%. In terms of confirming bug-sensitive warnings, FineWAVE demonstrates its proficiency in identifying 60.31% of bug-sensitive warnings with a precision of 75.52%. Moreover, compared to existing state-of-the-art (SOTA) methods, including “23 golden feature [61]”, “DeepInferEnhance [28]”, and “FRUGAL [56]”, FineWAVE showed improved performance, with a precision increase of 8.36%, and an F1-score boost of 11.97%. Additionally, we implemented FineWAVE on four popular real-world projects with over 1.5k stars (i.e., *itext7*, *metadata-extractor*, *poi*, and *pdfbox*). FineWAVE helps filter out 92.38% of the warnings with potential false alarms. Furthermore, through minimal manual effort, we discovered 25 new bugs based on the filtered warnings in these projects, 4 of which have been confirmed and fixed by developers.

In summary, this paper makes the following contributions:

- We provided BSWarnings, a dataset of 280,273 warnings including 20,100 bug-sensitive warnings constructed from 607,259 commits. This is the largest warning-related dataset to date, ten times larger than the currently largest dataset. We spent 6 months finishing 1,214,518 scanning tasks.
- We proposed FineWAVE, a novel neural approach to fine-grained warning verification of bugs for ASATs. We incorporate warning-aware slicing, warning information encoding, and cross-attention mechanisms for capturing complex semantics. To the best of our knowledge, we are the first to consider fine-grained warning verification and make it more practical for developers to confirm bugs.
- Experiments show that FineWAVE can reduce false alarms with an F1-score of 97.79%, and identify bug-sensitive warnings with 67.06%. Compared to eight baselines, FineWAVE can improve 8.36% in precision, and 11.97% in F1-score. Moreover, with the help of FineWAVE, we filter out around 92% of warnings and found 25 new bugs in four popular real-world projects.

2 PRELIMINARY

2.1 Automated Static Analysis Tools

Automated Static Analysis Tools (ASATs), popular in software development, are designed to analyze code for bugs and code smells without execution. Notable examples include SonarQube [53], SpotBugs [54] (formerly FindBugs [24]), and Infer [11]. In particular, SpotBugs [54] is an open-source static code analysis tool utilized in software development for bug detection in Java code. As the direct successor to FindBugs [24], it is among the most highly regarded tools in its domain. SpotBugs carries forward the same fundamental technology but with continuous support and improvements.

While ASATs are effective in bug detection during software development stages [8, 43, 57, 58], they depend on human-made rules or established patterns to identify known errors. The tendency of ASATs to generate an overwhelming number of warnings to cover potential bugs limits their usefulness in large software projects [7, 9, 19, 25, 37, 55]. To mitigate the occurrence of false alarms in ASATs, various methodologies have been proposed to identify truly beneficial warnings. One focal point of these studies is actionable warnings, i.e., warnings that developers would rectify over time. Such studies contemplate multiple features of the warnings and the accompanying code [20, 61, 62, 67]. However, there exist issues like data leakage and duplication that severely undermine the reliable identification of truly actionable warnings [27]. Moreover, actionable warnings may not reflect the remediation of bugs since it is based on the long span of commit history where the source code evolves greatly. Alternatively, Kharkar et al. utilized a learning method to minimize false positives [28]. They apply CodeBERTa as the foundation model to verify the function of related

warnings whether there is a bug and show an improved accuracy. Clearly, this method operates at a coarse granularity that considers only the entire function.

2.2 Motivating Example

When dealing with vast and numerous projects, developers often find themselves overwhelmingly burdened by a large number of the warnings reported by ASATs [19]. Hence, it is necessary to reduce the false alarm of the warnings. However, existing work can easily encounter problems due to the predefined features or the coarse granularity. They cannot effectively distinguish the individual warnings, which may result in mislabeling.

The following commit¹ is from project DongTai-agent-java of organization HXSecurity. It fixed a bug caused by `data.getBytes()` when the platform’s default charset is not compatible with the data being sent. Since the `CONTENT_LENGTH` header is not always necessary in a POST request, the fixed version has commented Line 5 out, and let the request automatically handle the content length.

```

1 private static StringBuilder sendRequest(...) throws Exception{
2     ...
3     if (HttpMethods.POST.equals(method)) {
4         ...
5         - connection.setRequestProperty(REQUEST_HEADER_CONTENT_LENGTH, Integer.toString(data.getBytes().length));
6         + //connection.setRequestProperty(REQUEST_HEADER_CONTENT_LENGTH, Integer.toString(data.getBytes().length));
7         ...
8     }
9     ...
10    InputStream is = connection.getInputStream();
11    BufferedReader rd = new BufferedReader(new InputStreamReader(is));
12    ...
13 }

```

Listing 1. A motivating example from DongTai-agent-java

SpotBugs reported a warning related to reliance on default encoding at line 5, which disappeared in the revised version. As such, it qualifies as a bug-sensitive warning. Meanwhile, SpotBugs issued a similar warning at line 13, involving the same function. Here, however, the `InputStream (is)` involves raw byte data obtained from the server response, which is then decoded into characters using the default charset. This operation actually functions correctly because the server’s response is encoded using a charset compatible with the default. Accordingly, we identified this as a bug-insensitive warning. Given that the two warnings originated from the same function, existing function-level learning-based warning verification methods and feature-based methods would consider the same input, potentially leading to mislabeling. Hence, to distinguish these bug-sensitive warnings from the bug-insensitive warnings and lower human effort when finding bugs using ASATs, a finer granularity method for the warning verification method is imperative.

2.3 Problem Definition

Our task is to facilitate developers to identify the bug-sensitive warnings, allowing us to reduce the burden on developers of sifting through potentially large numbers of irrelevant warnings, and instead focus their efforts on addressing bugs that have been identified with high confidence. We formally define the task as follows.

Let the space of the code snippet of a project be denoted as C and the set of all possible warnings as \mathcal{W} . In this context, the static analysis process can be defined as: $C \rightarrow \mathcal{W}$. Then, a bug-sensitive warning can be defined as follows:

¹<https://github.com/HXSecurity/DongTai-agent-java/commit/2822534>

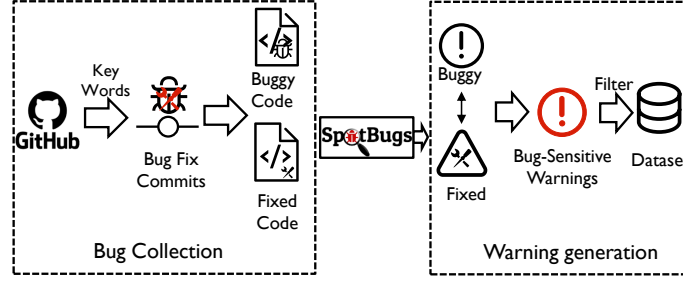

Fig. 1. The process of the data collection

$W_b = \{w \in \mathcal{W} \mid \exists (C_b, C_f) \in H : w \in SA(C_b) \text{ and } w \notin SA(C_f)\}$, in which (C_b, C_f) represents a bug in code C_b that is fixed in the corresponding code C_f .

With the warnings $\mathcal{W} = \{w_1, w_2, \dots, w_N\}$ and the corresponding code snippet $C = \{c_1, c_2, \dots, c_N\}$ as the input, the target is to distinguish the warning is bug-sensitive or bug-insensitive. Alternatively, a classifier model F may learn the mapping $C \times \mathcal{W} \rightarrow \mathcal{Y}$, where $y_i \in 0, 1$ indicates if the warning is bug-sensitive or bug-insensitive.

3 METHODOLOGY

3.1 Overview

In this section, we introduce FineWAVE, a deep learning-based (DL-based) approach to verifying bug-sensitive warnings of bugs for ASATs. Different from existing feature-based [61, 65] and learning-based approaches [28], FineWAVE is designed to automatically capture more comprehensive semantic information from the code, warnings and their interaction, applying it across a broader scope and with finer granularity warning verification.

3.2 Data Collection

Considering that current datasets of warnings are limited by coarse granularity, either in the dimension of time (i.e., actionable warnings) or code (i.e., function level), they do not align with our requirement for bug-sensitive warning verification, which demands a finer granularity. In addition, the scale of the existing datasets is limited to the specific projects. Hence, to construct an automated approach that verifies warnings of bugs via deep learning, our initial step involves creating a dataset, BSWarnings, gathering a large number of bug-sensitive warnings. The process of the collection is present in Figure 1.

Our process starts with a search for as many Java projects as possible. BSWarnings aims to be a high-quality dataset, so we filter the projects by GitHub stars to obtain the top 3% projects (i.e., around 32.1k Java projects). Then, we identify the manual bug-fixing commits within these projects to obtain a pair of buggy code and fixed code. Following previous work [21], we apply keyword filtering to the commit messages from these projects to identify the bug-fixing commits. Specifically, to be identified as such, a commit message must contain the word “fix” along with other bug-related words such as “bug”, “defect”, “error”, “fault”, “issue”, or bug classification words like “null pointer dereference”, “resource leak” etc. Using this filtering process, we collected a total of 607,259 related commits.

Subsequently, we cloned each corresponding project separately and switched to the bug version and fixed versions for further scanning. We compiled the projects and utilized SpotBugs on both two versions. Next, we make a comparison of the warnings generated from the relevant files in both the buggy and fixed versions of the commits. If the warning

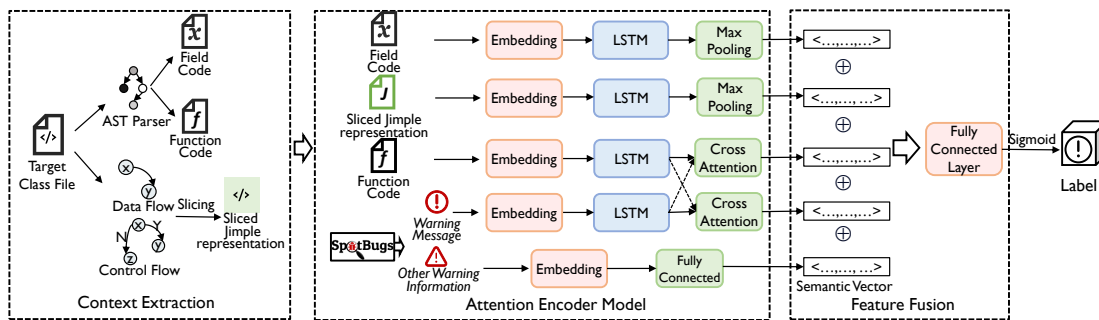

Fig. 2. The framework of our approach

disappears in the fixed version, we mark it as a bug-sensitive warning. Conversely, we interpreted that such a warning had no correlation to the specific bug, designating it as a bug-insensitive warning. Given that a single file might contain multiple bugs, which may not necessarily be fixed in a single commit, our collection faced a challenge. Some warnings may have been flagged repeatedly in the bug-insensitive warnings, as the bugs they refer to might not all be resolved simultaneously. To address this, we carried out a thorough data filtering and cleaning process. We implemented a criterion whereby once a warning is identified as bug-sensitive in any commit, it retains this classification, even if it appears in the bug-insensitive warnings for subsequent commits. As a part of this process, we also eliminated all duplicated warnings of bug-insensitive warnings. This process culminated in the creation of BSWarnings, comprising a total of 280,273 warnings, inclusive of 20,100 bug-sensitive warnings. To the best of our knowledge, this dataset represents the largest collection of warning-related data, dwarfing the size of the previously largest dataset by nearly ten times. We spent over 6 months on the process of running scanning tasks on three servers.

3.3 Fine-grained Warning Verification

Now we present our DL-based approach to bug-sensitive warning verification. Our approach includes four main components, i.e., code context extraction, warning information extraction, attention encoder model, and feature fusion. The framework of our approach is shown in Figure 2. Firstly, we extract the code context and warning information from the target class reported by specific warnings. Then, based on the code context and warning information, we design an attention encoder model on them to obtain a unified vector representation. The vector is finally used to determine whether the warning is bug-sensitive or not.

3.3.1 Code Context Extraction. The step of code context extraction consists of three key parts: warning function extraction, field of class extraction, and warning-aware slicing. The warnings provide the potential bugs present in a specific class and function with the specific lines. Due to the multi-modal sources involved in one warning, such as code, messages, and rules, it becomes necessary to extract sufficient and precise context for the model to effectively verify the warnings. Considering that the length of input for a neural model is typically limited, our context extraction of the code is within the target class.

Warning Function Extraction. To provide more related information for the network, we first focus on the function (i.e., method) on which the specific warning is reported. As described before, each warning points to the class where the bugs may exist, so we can locate the file for further extraction. However, due to the likelihood that the warning is missing the function name, in addition, there may be function overloading in the specific class, we extract the function

with the following criteria: (1) If the warning is reported with lines, we use the lines to locate the unique function. If the lines are not a specific function, we recognize the context of this warning is the whole class. (2) If the warning is reported with a function name, we locate all the functions with the same name as the context. Otherwise, we use the class as the context of the warning. In this step, we use ANTLR4 [44] to build the abstract syntax tree (AST) for the buggy file and then obtain the function. If we cannot find the function corresponding to the line number, or if there is no line number available, we use the entire class content to fill in this input.

Field of Class Extraction. In addition, considering the characteristics of the Java language, Java fields, i.e., member variables in a class [42], which are declared inside a class, but outside any method, constructor, or block, can be related to all functions. Java fields have a unique attribute that distinguishes them from local variables and parameters. They are object-specific and have potentially different values for different objects of the same class. Fields can be categorized as public, private, or protected, which are visibility modifiers that define how and from where these fields can be accessed. This external context might also hold key clues related to various potential errors. For instance, issues like incorrect field initialization could lead to unexpected application behavior, while null pointer exceptions might arise from fields not being properly instantiated. We start with the AST constructed by the code file. Then, we locate the root of the class and traversal the class. If the node is the definition of variables and does not belong to any function method, we classify it as a part of the fields. Finally, we obtain all the field codes in the related class.

Warning-Aware Slicing. Although we have pinpointed the exact function where the warning was issued, the data fed into our model might be noisy, e.g., the data dependency does not influence the specific bugs, arbitrary names of local variables, hindering its ability to concentrate on the specific buggy lines and their directly related fragments. To mitigate this, we introduce a warning-aware slicing on the function. The slicing aims to (1) isolate all relevant dependencies, thereby ensuring the model’s focus remains strictly on the essential elements related to the bug; (2) restructure the program and unify variable names.

```

1 $stack61 = virtualinvoke data.<java.lang.String: byte[] getBytes()>()
2 $stack62 = lengthof $stack61
3 $stack63 = staticinvoke <java.lang.Integer: java.lang.String toString(int)>($stack62)
4 virtualinvoke connection.<java.net.HttpURLConnection: void setRequestProperty(java.lang.String, java.lang.String)>("
   Content-Length", $stack63)

```

Listing 2. An example of Jimple

Specifically, we set the lines that warning reported as the slice criteria, and do the backward and forward slice according to the slice criteria. We first use Soot [1] as the analysis framework and construct the program dependency graph (PDG) of the project. For the backward slice, we focus on the variable read in the slice criteria and find all nodes in the PDG that are directly or indirectly dependent on the specified program point starting from the slice criteria. As for the forward slice, we focus on the variable written in the slice criteria and still find all nodes that are directly or indirectly dependent. Note that our slices are confined to the function’s scope, as interactions between the function and class are intricate. These interactions could involve semantics associated with other warnings, thereby leading to the potential misguidance of our model. Finally, we obtain the sliced function code originally in the form of the IR in Soot, i.e., Jimple. Jimple is a typed 3-address IR. It provides a more standardized and simplified view of observing program behavior, which can assist the model understanding the semantics of complex statements (e.g., multiple calls) and excluding the interference from the semantics of some local variables.

As shown in the Listing 2, the code snippet is Jimple representation of the Java code Line 5 in Listing 1. The original Java code has been converted to three typed 3-address statements. The statements break down complex expressions

Table 1. The details of the warning Information

Information	Description
Message	Error message generated by SpotBugs for warning description.
Rule	The scanning rule for triggering the warning.
Category	The category of the rule belongs to (e.g., CORRECTNESS).
Rank	A specified bug severity rank of warning.
Confidence	A particular bug confidence of warning reported.

and statements into simpler ones that perform a single operation and have at most one side effect. For example, the original code Line 5, involves many assignments (e.g., `length`) and function invoke (e.g., `getBytes`, `toString`, and `setRequestProperty`). The Jimple code divided the code in Line 5 into several different statements. In addition, the intermediate variables are simplified (e.g., `stack61`). Hence, by unifying the local variables, splitting the complex semantics, Jimple representation can guide the model more effectively to locate the bugs from the given function and messages. Again, if there is no corresponding function, we use the entire class’s Jimple as a filler.

3.3.2 Warning Information Extraction. Besides the code context we mentioned, some warning Information needs to be provided to the model. First of all, we collect the messages of each warning, which include the details of the potential bugs and can serve as a filter for the model to identify the buggy semantics. Then, we gather the rule and category attributes for the model to distinguish different types of potential bugs. Finally, we also collect the rank and confidence of the warning for the model to judge the risk of potential bugs and possible concerns of the ASATs. The details of the warning attributes used are shown in Table 1.

3.3.3 Attentional Encoder Model. Unlike existing learning-based warning verification methods that apply pre-trained large models like CodeBERT and GPT-C, our method applies a relatively lightweight model. This enables us to explore dedicated strategies for capturing more precise semantics. In particular, we design an attention encoder model, including five embedding layers, four LSTM models, two max-pooling layers, two cross-attention modules and two fully connected layers. The five embedding layers and four LSTM models separately encode the function code, the field code, the sliced Jimple representation, the warning message, and warning attributes (i.e., rule, category, rank, and confidence features). This rationale for choosing LSTM is supported by prior research [15, 34, 71], which has demonstrated their effectiveness in similar contexts. Considering that the message information describes semantics in the code and that the semantics in the code may be contained in the warning message, we perform cross-attention on the sliced function code and warning message separately. After encoding the field code, the sliced Jimple representation, and warning attributes through max pooling and full connection, we obtain five semantic vectors.

Formally, let f denote the sequence of words w_1, w_2, \dots, w_n in a specific function, and an embedding layer is applied to initialize the sequence by vectors:

$$f_i = W_e^\top w_i, i \in [1, n], \quad (1)$$

where n is the length of the sequence (i.e function f), W_e is the embedding matrix. Then, we employ a Long Short-Term Memory (LSTM) [68] to encode the sequence of vectors $F = \{f_1, f_2, \dots, f_n\}$ into hidden states $H_f = \{h_1, h_2, \dots, h_n\}$. To capture the semantics before and after the current position, we further use a Bidirectional LSTM (Bi-LSTM) [52] on it. In this step, we formalized the result is

$$h_j = Bi-LSTM(f_j, h_{j-1}) \quad (2)$$

Similarly, we obtain the hidden states of field code, sliced Jimple representation, and warning message by three new Bi-LSTMs. For ease of illustration, we mark them as H_{fc} , H_J and H_m respectively.

After encoding all the code and message, we design a cross-attention mechanism on the vector representations of function code and warning message. Given the hidden states of function code are $H_f = h_{f_1}, h_{f_2}, \dots, h_{f_n}$, we first calculate the query vector q_f by max pooling H_f as follows:

$$q_f = \text{maxpooling}(H_f) \quad (3)$$

The context vector V_f is computed using the following formula:

$$V_f = \sum_{i=1}^n \alpha_i \cdot h_{m_i} \quad (4)$$

where n is the number of hidden states in the function code, and α_i is the attention weight for each hidden state h_{m_i} , calculated as follows:

$$\alpha_i = \frac{\exp(q_s \cdot h_{m_i})}{\sum_{j=1}^n \exp(q_s \cdot h_{m_j})} \quad (5)$$

The context vector V_f is the weighted sum of the hidden states based on their attention weights, allowing the model to focus on the most relevant semantics of the warning message. For simplicity, we notate the process as $V_f = \text{Attention}(q_f, H_m)$. In this way, we depict the relationships between the whole semantics of the sliced function and the words in the warning message.

Following the process, we can obtain the context vector of the message V_m , which captures the relationships within the sliced function through a query vector q_m . That is, $V_m = \text{Attention}(q_m, H_f)$. By computing the attention weights in a mutual manner, we can better acquire the correlations between the sliced code and the warning message.

For the field code vector, H_{fc} , we apply a max pooling on it, to achieve a semantics vector by $V_{fc} = \text{maxpooling}(h_{fc})$. Similarly, for the sliced Jimple representation, we obtain a semantics vector V_J by max pooling. Besides, to leverage other attributes of warnings, we encode these attributes separately as vectors. Suppose that the t -th attributes is a_t , where W_{e_t} is the weight of the attributes t , we first embed it into $x_t = W_{e_t}^\top a_t$, $t \in [1, 4]$ and then apply a fully connected layer on it. That is, $V_{a_t} = W_a^\top x_t + b_t$. These encoded attributes are then combined into an integrated feature vector, denoted as V_a . As a result, we obtain 5 vectors for the semantics from different aspects.

3.3.4 Feature Fusion. Based on the above calculations, we have obtained five semantic vectors, field code vector V_{fc} , function code vector V_f , sliced Jimple representation vector V_J , warning message vector V_m , and other warning attributes vector V_a . Further, we need to integrate these four vectors to obtain a single vector by concatenating the vector. The calculation is as follows:

$$V = V_{fc} \oplus V_f \oplus V_J \oplus V_m \oplus V_a \quad (6)$$

Finally, we employ a fully connected layer on the vector V to get the final vector V_l , the formula is shown as follows.

$$V_l = W_o^\top v_i + b_i \quad (7)$$

3.3.5 Focal Loss. Since ASAT will explode with a large number of warnings, the data we collected also face a situation where bug-sensitive warnings and bug-insensitive warnings samples are extremely imbalanced (i.e., close to 1:15). Therefore, during the training process, we used focal loss [36] to handle this situation. The Focal Loss function handles the issue of class imbalance in training exercises such as object detection. It modifies the cross entropy loss with a modulating term to concentrate on challenging instances of misclassification. The Focal Loss function is essentially

a cross-entropy loss that is scaled dynamically, where the scaling component reduces to zero as the certainty in the accurate class rises. Hence, training our method is to minimize the loss function:

$$FL(p_t) = -\alpha_t(1 - p_t)^\gamma \log(p_t) \quad (8)$$

$$p_t = \exp\left(\frac{1}{N} \sum_i -[y_i \log(p_i) + (1 - y_i) \log(1 - p_i)]\right) \quad (9)$$

where α and γ is the tunable focusing parameter, y_i is the label of i , p_i is the probability of predicting a bug-sensitive warning. To train the model, we apply the sigmoid activation function as the last linear layer for warning verification, and obtain the vector L , which represents the possibility that the corresponding warning is bug-sensitive. After optimizing all the parameters, the models are trained. They output probabilities L for different labels. Therefore, we obtain the prediction using the following equation:

$$\text{Prediction} = \begin{cases} \text{bug-sensitive,} & L > \delta \\ \text{bug-insensitive,} & L \leq \delta \end{cases} \quad (10)$$

where δ is the threshold.

4 EVALUATION

4.1 Dataset Evaluation

Since existing datasets are not applicable to our fine-grained warning verification task, we collected BSWarnings with 280,273 warnings according to our method. However, the quality of the dataset still may affect the validity of our methods. Although we have employed a keyword filter and warning comparison approach to avoid invalid warnings, it is possible to introduce some warnings with incorrect labels. Hence, we conduct a manual evaluation of the dataset. We sampled 384 warnings in BSWarnings according to a confidence level of 95%, including 27 bug-sensitive warnings and 357 bug-insensitive warnings following the original proportions in BSWarnings which can more effectively reflect the quality of the dataset. Then, we invited 3 experienced senior developers with frequent use of SpotBugs from our industry partner to evaluate the sampled data. To keep the quality of evaluations, the developers can receive a bonus after conducting effective evaluations. First, we asked three evaluators to individually assess the sampled data. For bug-sensitive warnings, evaluators should judge whether each warning is related to the specific bug. For bug-insensitive warnings, the evaluators should observe whether these warnings are completely useless or whether these warnings might contain other bugs. Based on this, we required the three evaluators to discuss and reach a consensus on each warning, confirming whether the labels of the warnings are correct. Ultimately, the three evaluators reported that among the 27 bug-sensitive warnings, 2 were mislabeled, and among the 357 bug-insensitive warnings, 13 were mislabeled. In conclusion, BSWarnings has an accuracy rate of 92.60% on bug-sensitive warnings and 96.36% on bug-insensitive warnings with a confidence of 95%.

4.2 Experiment Setup

We carried out the experiments on BSWarnings originally consisting of 280,273 warnings. For the purposes of training, validation, and testing, we divided BSWarnings in an 8:1:1 ratio. Additionally, we applied our trained model to four open-source projects to evaluate the performance of FineWAVE in real-world scenarios.

We implement FineWAVE based on pytorch 1.8.0. In the training process, we set the vocabulary size to 100,000, the embedding size to 512, and the hidden state size of LSTM to 512. We set the batch size to 64 and adopt the Adam [31]

as the optimizer. The learning rate is $5e-5$ with a decay when the F1-score for the bug-sensitive samples has stopped improving. The hyper-parameter of focal loss α and γ is set to 0.05, 2 respectively. All aforementioned hyper-parameters are chosen from a range of alternatives, based on their performance on the validation set. All the experiments are conducted on one Ubuntu 18.04 server with 48 cores CPU, 252GB RAM, and two NVIDIA RTX 3090 GPUs with 24GB memory.

4.3 Baselines

FineWAVE represents the first of its kind in verifying ASAT warnings at a fine-grained warning level. To demonstrate its effectiveness, we conducted a comparative analysis with existing representative methods of warning verification that operate at different levels of granularity. These methods include: “23 Golden Feature [61]”, “FRUGAL [56]”, and “DeepInferEnhance [28]”. Additionally, we also involve in other four methods including the GraphCodeBERT model, the transformer model, the LSTM model, and the N-grams model. In our comparisons, we adopted the default settings for these methods unless specified otherwise.

4.3.1 23 Golden Feature. Wang et al. and Yang et al. conduct a study on existing features to predict actionable warnings and identified key attributes as “23 golden features” [61] [65]. The features include 8 categories, involving file, history, code, and warnings. Based on this, Kang et al. continue the research on golden features and employ kNN ($k=1$) to achieve the best performance. Hence, we followed the settings of Kang’s method to replicate the feature-based approach.

4.3.2 FRUGAL. In addition to the aforementioned supervised learning method, there is a semi-supervised learning method, FRUGAL, for actionable warning verification. FRUGAL, was introduced by Tu et al. [56], and achieved nearly the same result with supervised learning in actionable warning verification. For this baseline, we use the code provided in their official repository.

4.3.3 DeepInferEnhance. This approach[28], introduced by Kharkar et al, employs a pre-trained model CodeBERTa to determine if code functions flagged by warnings indeed contain bugs. We specifically chose CodeBERT [16] for its superior performance, and establish it as a baseline for our study. In addition, as our work takes SpotBugs as input and carries out fine-grained warning prediction, we also made some modifications to the DeepInferEnhance model. We input both the warning message and code simultaneously and used a fully connected layer to fuse these two aspects, making it our baseline.

4.3.4 GraphCodeBERT Model. In addition to the aforementioned CodeBERT model in DeepInferEnhance, we also used another pre-trained model GraphCodeBERT [17]. This model incorporates data flow into the foundation of CodeBERT, resulting in superior semantic understanding compared to CodeBERT. There are some studies that use GraphCodeBERT to detect bugs and vulnerabilities [40, 63]. For this baseline, we used the same settings as CodeBERT. The input lengths of the code and the message are 512 and 32, respectively.

4.3.5 Transformer Model. We additionally use a common transformer [59] to replace the pre-trained model. Transformers can effectively extract semantic information from code and there are also some studies [4, 46] to predict bugs and vulnerabilities based on it. Samely, we concatenate the code and message together and use a fully connected layer to obtain the label. The input size of the code and message are 512 and 32. The hidden dimension of the transformer is 1024. The numbers of heads and encoders are 8 and 6, respectively.

Table 2. Results comparison for warning verification (DeepInferEnhanceWM refers to DeepInferEnhance with messages)

Methods	Bug-Sensitive Warnings			Bug-Insensitive Warnings			Overall		
	Precision (%)	Recall (%)	F1-Score (%)	Precision (%)	Recall (%)	F1-Score (%)	Precision (%)	Recall (%)	F1-Score (%)
23 Golden Feature	51.47	51.04	51.25	97.00	97.05	97.02	54.10	53.70	53.90
DeepInferEnhance	49.59	44.89	47.12	95.46	96.21	95.83	53.11	48.83	50.86
DeepInferEnhanceWM	59.51	47.86	53.05	95.74	97.29	96.51	62.29	51.65	56.38
GraphCodeBERT	59.30	47.00	52.44	95.67	97.32	96.49	62.09	50.86	55.82
FRUGAL	5.62	85.53	10.36	93.24	12.43	20.11	10.69	81.30	10.92
Transformer	51.03	51.99	51.51	95.89	95.73	95.81	54.57	55.44	55.00
LSTM	59.45	49.28	53.89	95.72	97.12	96.42	62.31	53.05	57.24
N-grams	66.49	39.96	49.92	95.22	98.34	96.76	68.67	44.39	53.48
FineWAVE	75.52	60.31	67.06	97.08	98.51	97.79	77.03	62.99	69.21

4.3.6 *LSTM Model.* In this model, we use LSTM [52, 68] as the encoder to replace the transformer. We encode the code and message separately and concatenate them. The hidden dimension of LSTM is 1024, and the n layers of LSTM is 1. Based on this, we apply a fully connected layer to obtain the label.

4.3.7 *N-grams Model.* Lastly, we used an n-grams[10] model as a baseline. N-grams are widely used in natural language processing and computational linguistics. We concatenate the code and message together as input to verify the validity of the warning (n=3). We built a vocabulary using TF-IDF [47] and applied a linear SVM as the machine learning method, ultimately obtaining our baseline.

4.4 Results and Discussion

We present the results of our experiments and delve into the analysis by answering the following research questions (RQs).

4.4.1 *RQ1: How effective is FineWAVE compared to the baseline models?* Table 2 presents a comparative analysis of FineWAVE and various baseline models in terms of their ability to verify warnings (i.e., bug-sensitive warnings & bug-insensitive warnings). The metrics used for comparison include precision, recall, and F1-score, calculated separately for bug-sensitive and bug-insensitive warnings. Additionally, overall values are computed using a weighted approach, where fewer test samples correspond to higher weights. The highest values across all columns are highlighted in bold. As depicted in Table 2, FineWAVE effectively reduces the cost of manually verifying warnings. It can verify 60.31% of bug-sensitive warnings with 75.52% precision and can also filter 98.51% bug-insensitive warnings with 97.08% precision. Overall, FineWAVE performs with 69.21% F1-score in the warning verification at a finer granularity.

Compared to other methods, FineWAVE generally outperforms the eight baseline models. The “23 golden feature” method, which previously performed well, appears to be less effective when dealing with more fine-grained bug-sensitive warnings, with an overall 53.90% F1-score. The primary reason is that fine-grained bug warning detection demands the capture of extensive semantic information. However, the method in question relies on a set of fixed features, which are insufficient to cover the diversity and complexity of bug semantics. The manually extracted semantics may provide identical features in certain scenarios that are challenging to distinguish, thereby making it difficult for the classifier to differentiate them and resulting in a notably low recall and precision. As shown in § 2.2, Listing 1 is a typical example where “23 golden feature” performs failed in the warning verification. Spotbugs reported a warning in the function sendRequest of line 5 and line 13 with the same warning type. Hence, the warning characteristic features and code

features can not distinguish them. In addition, because the codes are both introduced in the first commit of the project, the features of warning history also failed in finding differing aspects of them. Consequently, the classifier recognizes the two warnings are the same warnings and fails to verify these warnings.

Despite DeepInferEnhance undergoing pre-training on a large code corpus, it fails to meet the characteristics of this challenging task. A notable limitation arises when the input lacks a warning message; the original model struggles to accurately differentiate between various warnings within the same function. This leads to a modest F1-score of 50.86%. In contrast, incorporating warning messages into the analysis improves the F1-score by 5.52%. As for another pre-trained model, GraphCodeBERT, which have shown better performance than CodeBERT in other tasks, also struggles to accurately verify bug-sensitive warnings, with only 55.82% F1-score. While these pre-trained models are adept at understanding the general behaviors of code, they neither deal with the noise (e.g., some unrelated variable), nor depict the correlation between the code and the warning information. Additionally, these models break the identifiers down into sub-tokens, which makes it hard to capture the dependencies between those elements. This result is consistent with previous studies that acknowledged the limited advantage of pre-trained models in defect prediction [3].

FRUGAL, as a semi-supervised learning method, previously demonstrated comparable performance to supervised feature-based methods in actionable warning verification. However, its effectiveness significantly diminishes in the bug-sensitive warning verification, achieving only a 10.92% F1-score. One reason is the inherent challenge FRUGAL faces with extremely imbalanced datasets. In such scenarios, models may develop a bias towards the class with higher weight due to its more abundant information, leading to subpar predictions for the minority class [18, 45, 66]. In our experiments, to improve the F1-score for bug-sensitive warning verification, the model tended to over-predict bug-sensitive warnings. This approach increased recall but adversely affected precision. Additionally, this strategy also resulted in a decreased recall for bug-insensitive warnings. Another contributing factor to FRUGAL’s under-performance in finer granularity tasks is the potential inappropriateness of its original features for the nuanced requirements of bug-sensitive warning verification.

Regarding basic alternatives, their performance still falls short of adequacy. The transformer model, lacking pre-training, faces challenges in effectively learning code semantics and interpreting warning messages. This difficulty in training resulted in a suboptimal performance, achieving only a 55.00% F1-score. The n-gram method, another baseline, exhibits average performance, yet a little lower than “23 golden feature”. This suggests that while the n-gram model can capture related patterns, its performance is hampered by noise and inability to learn deep semantics. We also find that as the base component of FineWAVE, the LSTM model outperformed the pre-trained models. This can be partly attributed to its strict orderliness of encoding, which makes it easier to learn the naturalness of source code, thereby acquiring more sequential dependencies. Therefore, their performance was not as good as that of the LSTM.

In conclusion, FineWAVE considers more elements (including field code and warnings), integrates the function slicing to obtain rich while precise context and takes into account the interaction between warning messages and code. These enhancements allow FineWAVE to outperform the baseline models, underscoring its effectiveness in verifying warnings.

Answer to RQ1: *Compared with the eight baseline models, FineWAVE demonstrated superior performance, achieving improvements of at least 8.36% in precision, and 11.97% in F1-score. These results underscore the effectiveness of FineWAVE in verifying bug-sensitive warnings.*

4.4.2 RQ2: How effective are the individual components of FineWAVE? In this research question, we explore the impact of the key components of FineWAVE on its overall effectiveness. Our methodology primarily incorporates four components: warning-aware slicing, field code, cross-attention mechanism, and focal loss. To evaluate the significance of these

Table 3. Effectiveness of the main components of FineWAVE

Components	Precision (%)	Recall (%)	F1-score (%)
- Field Code	72.89	60.50	66.04
- Warning-Aware Slice	72.72	64.14	68.12
- Cross-Attention	68.67	66.71	67.67
- Focal Loss	71.94	64.18	67.81
LSTM→Transformer	69.38	62.08	65.50
FineWAVE	77.03	62.99	69.21

individual components, we conducted an ablation study of FineWAVE by removing each component and observing the consequent effects on performance. Moreover, to further assess the impact of our design choices, we experimented by substituting the LSTM in our encoder with a transformer architecture.

The impact of each individual component of FineWAVE on its effectiveness is detailed in Table 3. Our first step was to remove the Field Code component, which resulted in a 3.17% decrease in the F1-score. This decline can be attributed to the diminished ability of the model to fully understand certain function code statements in the absence of the class variable segment provided by the Field Code. Consequently, this led to the model missing warnings that may contain bugs, resulting in false positives and inaccurate verification.

Upon the removal of the slicing component, a decline in FineWAVE’s effectiveness was observed, with a 1.09% decrease in the F1-score. Without this component, the model can encounter some noises (e.g. unrelated data flow in the same function), which adversely affects the tool’s focus on locating the bug information. Consequently, the precision of warning verification decreases by a large margin. Similarly, when we removed the Cross-Attention component, there was a 1.54% decline in the F1-score, and notably, a substantial 8.36% drop in precision. As discussed earlier, the Cross-Attention mechanism is indeed important for facilitating the mutual integration of warning messages and code information. These results indicate that it is essential to consider precise semantics for the fine-grained warning verification.

We also assessed the impact of excluding the Focal Loss component, which was initially employed to manage the significant imbalance in BSWarnings, where only 7% of warnings are bug-sensitive. Removing this component led to a modest decrease in the F1-score by 1.40%. Specifically, replacing Focal Loss with Cross-Entropy Loss resulted in a decrease in precision by 5.09%, but there was an increase in recall by 1.19%. The results suggest that Focal Loss’s emphasis on less represented samples enhances the model’s ability to gather more bug-related information, thereby contributing to increased precision.

Finally, when we substituted the LSTM encoder in FineWAVE with a Transformer model, contrary to expectations, there was a decrease in performance, dropping to 65.50% while we expect the self-attention mechanism of the Transformer to enhance FineWAVE’s performance. The Transformer model processes tokens differently from LSTM, and this fundamental variance in semantic extraction could be the reason behind the diminished performance. Specifically, the self-attention mechanism of the Transformers may focus on too many irrelevant dependencies, which makes LSTM a more suitable choice for our specific application.

Answer to RQ2: *The effectiveness of each component of FineWAVE varies slightly, impacting performance by 1% to 4%. Field Code improves recall by broadening the context, while Warning-Aware Slicing and Cross-Attention enhance precision by focusing on more accurate semantics. Focal Loss slightly increases the F1-score and precision by better semantic extraction.*

4.4.3 RQ3: *What is the effectiveness of FineWAVE across different warning categories?* In this RQ, we analyze and discuss the effectiveness of FineWAVE in various categories of SpotBugs. Our classification comes from SpotBugs’ categorization of its detection rules. There are a total of 10 types of categories in SpotBugs, i.e., *Correctness* (apparent coding mistakes), *Experimental* (experimental bug pattern), *Internationalization*, *Malicious code*, *Multithreaded correctness*, *Bogus random noise*, *Performance*, *Security*, and *Bad Practice*. Because the *Bogus Random Noise* category intended to be useful as a control in data mining experiments, not in finding actual bugs in software, we excluded it from our analysis.

As shown in Table 4, FineWAVE achieves high performance in the *Bad Practice*, *Correctness*, and *Performance* categories, with overall F1-scores over 70%. *Bad Practice* warnings, often involving simpler bug patterns related to variable issues, are most effectively detected due to the model’s focus on field code and variable-related semantics. In the *Correctness* category, which includes a variety of potential coding errors, our tool performs well, though some complex bugs needing more information may not be detected. The *Performance* category, similar to *Bad Practices*, shows good results, especially in identifying issues like unused code and inefficient loops. However, our tool might not always catch performance issues that are indirectly linked to bugs.

For *Security* category, FineWAVE performs worst on it, only achieving an F1-score of 38.53%. It is worth noting that there are very few bug-sensitive warnings in this category. BSWarnings contains a limited number of bug-sensitive warnings in the *Security* category, totaling only 63 instances. This scarcity of examples for the model to learn from could be a contributing factor to its low performance in validating issues within this specific category. This phenomenon also aligns with the result in the Fluffy on the classification of unexpected path-traversal flow [12]. Besides, accurately determining if these rules align with specific security issues in the code demands consideration of external factors, like inter-procedure dependencies and the execution environment.

For the other five categories, FineWAVE’s performance hovers around a 65% F1-score, consistent with its overall effectiveness. Specifically, *Multithreaded Correctness* and *Experimental* exhibit similar levels of precision and recall which indicates that FineWAVE presents a balanced ability on them due to its components. The other three categories, however, show a stronger performance in precision. This pattern suggests that while FineWAVE is adept at the detailed analysis of code and warnings, it sometimes misses nuances related to specific bug dependencies. The results across these categories reflect the tool’s capability in handling a variety of code issues, though it also highlights areas for potential refinement in targeting bug-specific dependencies.

Answer to RQ3: *FineWAVE performs differently across various categories, with F1-scores ranging from 38.53% to 77.94%, precision ranging from 51.66% to 84.87%, and recall ranging from 31.04% to 72.36%. Among them, our model performs best in the Bad Practice category, and worst in the Security category mainly due to a small number of bug-sensitive warnings for it.*

4.4.4 RQ4: *How does our tool fare when applied to real-world scenarios?* In this RQ, we discuss how our model performs in the real world, and whether it can verify (in)valid warnings. To achieve this, we applied FineWAVE to 4 popular OSS projects which have over 1.5k stars, i.e., itext7, metadata-extractor, poi, and pdfbox. Initially, we compiled the code and used SpotBugs to scan them, respectively. By analyzing the SpotBugs reports, we totally obtained 7,235 warnings from 4 projects.

Table 4. Effectiveness of each category of FineWAVE

Categories	Precision (%)	Recall (%)	F1-score (%)
<i>Bad Practice</i>	84.87	72.23	77.94
<i>Correctness</i>	73.20	72.36	72.78
<i>Performance</i>	78.49	65.65	71.38
<i>Dodgy code</i>	76.92	59.95	67.24
<i>Malicious code</i>	77.11	59.51	67.09
<i>Experimental</i>	67.93	63.94	65.87
<i>Internationalization</i>	72.94	56.14	63.31
<i>Multithreaded correctness</i>	62.78	59.96	61.33
<i>Security</i>	51.66	31.04	38.53
FineWAVE	77.03	62.99	69.21

Then, we applied FineWAVE on these warnings to filter out the false positives (i.e. bug-insensitive warnings). In this step, there remained 551 warnings (7.62%) in all projects. Based on these filtered warnings, we performed a manual check on each warning. For each warning, we not only analyze the warning’s type and information to determine if the reported line is the root cause, but we also search for corresponding call issues based on the clues provided by each warning. This allows us to confirm whether the warning is part of the triggering chain of certain bugs. Finally, we totally found 25 bugs in the warnings validated by FineWAVE. We have submitted these bugs to the relevant developers and 4 of them have been confirmed and fixed by developers.

```

1 public void nextValidToken() throws java.io.IOException {
2   ...
3   else if (tokenValueEqualsTo(Obj)) {
4     assert n2 != null;
5     type = TokenType.Obj;
6     reference = Integer.parseInt(new String(n1));
7     generation = Integer.parseInt(new String(n2));
8     return;
9   }
10  ...
11 }

```

Listing 3. Bug example of nextValidToken method in itext7

Case Study: As shown in the Listing 3, after filtering through our tool, we obtained two warnings: “Found reliance on default encoding in lines 6 and 7”. We manually analyzed these two warnings and conducted an analysis of the entire function. We found that line 6 and line 7 could potentially lead to problems if the byte arrays contain data that is not compatible with the default charset. If the bytes do not represent valid characters in the default charset, the resulting string could contain unexpected or incorrect characters, which could then cause `Integer.parseInt()` to throw a “NumberFormatException”. To avoid this potential issue, it is generally recommended to specify a charset when converting bytes to a string. We have reported this issue to the developers.

Answer to RQ4: According to the result of applying FineWAVE on 4 OSS projects with over 1.5k stars (i.e., *itext7*, *metadata-extractor*, *poi*, *pdfbox*), FineWAVE can help remove 92.38% of the warnings with potential false alarms, and enable us to discover 25 new bugs in these projects, 4 of which have been confirmed and fixed by developers.

5 THREATS TO VALIDITY

5.1 External Validity

As detailed in § 3.2, our data collection process involved identifying bug-related keywords in commit messages from GitHub’s Java projects. However, due to potential inaccuracies in commit descriptions, some commits may not be bug fixes or may contain unrelated changes, impacting BSWarnings’s quality. Furthermore, the process of collecting warnings may also involve some poor-quality warnings which are not related to the specific bug. Hence, we manually sampled 384 warnings to assess BSWarnings, finding an accuracy rate of 92.60% for bug-sensitive warnings and 96.36% for bug-insensitive warnings, with a 95% confidence level.

5.2 Internal Validity

A potential threat to internal validity refers to the generalizability across ASATs. Following the existing research focusing on single ASATs [28, 61, 65], FineWAVE was initially evaluated using SpotBugs. To mitigate this threat and enhance the generalizability of our method, FineWAVE is intentionally designed not to depend on features unique to any specific ASATs. This strategic decision ensures that our method can be broadly applicable and effective across a range of ASATs, facilitating its direct adaptation to other tools. Moving forward, our future work will expand to include a wider variety of ASATs, further broadening the scope and applicability of our approach.

6 RELATED WORK

6.1 Learning-Based Method for Warning Verification

Most existing work on reducing false alarms focus on using feature involved in many aspects of warnings, code, and history information to predict actionable warnings. For example, Heckman et al. employed 51 features and evaluated 15 machine learning methods to achieve high accuracy [22]. Kim et al. used software change history to prioritize warning categories and proposed an algorithm for warning category prioritizing [29, 30]. Liang et al. proposed 3 impact factors as features on a new heuristic for identifying actionable warnings [35]. Ruthruff et al. applied a screening method on existing logistic regression models to achieve a cost-effectively built prediction model to predict actionable warnings. Hanam et. al proposed a method to distinguish actionable warnings by finding alerts with similar code patterns [20]. Based on these methods and features, Wang et al. proposed a “Golden Feature” of 23 key attributes to achieve an AUC over 0.95 using linear SVM [61, 65]. However, Kang et al. found that there are leaked features and data duplication in the data, which can lead to a sudden drop in effectiveness [27]. Moreover, Tu et al. tried to unlock the semi-supervised method for actionable warning verification. They proposed FRUGAL, a tuned semi-supervised method that executes on a simple optimization policy and outperforms the supervised learning methods for actionable warning verification. In addition, there is also another study to verify warnings at a function level. Kharkar et al. proposed a transformer-based learning approach to identify the false alarm on ASATs Infer [28].

Our work is quite different from theirs: (1) We focus on a new concept: bug-sensitive warnings, a finer granularity. Compared with existing methods, our method verifies warnings sensitive to bug fixing and can reduce labour costs on bug finding. (2) Compared to the feature-based method, our approach does not require manual extraction of semantics but aims to extract semantics by deep learning method automatically. Compared to the transformer-based method, our method considered more semantics in warnings while they ignored the semantics of warnings. (3) Our method applied a larger dataset and extensive adaptability on wider projects instead of specific projects. We collected BSWarnings with

280,273 warnings including 20,100 bug-sensitive warnings on 32.1k real-world projects. BSWarnings is 10 times larger than the existing one.

6.2 Reanalysis-based Methods for Improving ASATs

There are also some alternatives working towards a different direction for improving ASATs. Most of them tried to cut the unreachable path of the program. For example, Junker et al. presented a method which views static analysis as a model-checking problem to prune the infeasible path using SMT-solvers to reduce the false positive warnings [26]. Nguyen et al. applied deductive verification to eliminate false alarms [38, 39]. There are also some methods employing dynamic analysis to improve ASATs. For example, Li et al. proposed residual investigation, a dynamic analysis to predict errors in executions, to judge the validity of a warning [33]. Csallner et al. presented a method combined with ASATs with concrete test-case generation to identify the real warnings [13]. What's more, there are also some studies with the simplification of manual inspection. These methods tried to screen warnings by semi-automatically inspecting [48, 49], feedback-based pruning [51] and checklist based inspection [43]. Our work mainly applied deep learning to bug-sensitive warning prediction. Thus, there is a distinction from the above described tools.

7 CONCLUSION

In this paper, we formulate the problem of warning verification at a fine-grained level, focusing on bug-sensitive warnings. We first constructed BSWarnings, a dataset with 280,273 warnings, of which 20,100 warnings are bug-sensitive. To the best of our knowledge, this is the largest collection of data on warnings, ten times larger than the existing one. Then, we proposed FineWAVE, a novel LSTM-based model for fine-grained warning verification of bugs for ASATs. FineWAVE employs a multi-faceted representation which captures fine-grained semantics of source code and warnings from ASATs and focuses more on their correlations with cross-attention. With an extensive experiment, FineWAVE shows an F1-score of 97.79% for reducing false alarms and 67.06% for confirming effective warnings. Compared with baselines, FineWAVE outperforms 8.36% in precision, and 11.97% in F1-score. Moreover, we employed FineWAVE on four real-world projects to filter out about 92% warnings and then found 25 new bugs with minimal manual effort.

REFERENCES

- [1] 2023. Soot - A framework for analyzing and transforming Java and Android applications. <https://soot-oss.github.io/soot/> (Accessed on 01/12/2023).
- [2] Edward Aftandilian, Raluca Sauciu, Siddharth Priya, and Sundaresan Krishnan. 2012. Building Useful Program Analysis Tools Using an Extensible Java Compiler. In *2012 IEEE 12th International Working Conference on Source Code Analysis and Manipulation*. 14–23. <https://doi.org/10.1109/SCAM.2012.28>
- [3] Wasi Uddin Ahmad, Saikat Chakraborty, Baishakhi Ray, and Kai-Wei Chang. 2021. Unified pre-training for program understanding and generation. *arXiv preprint arXiv:2103.06333* (2021).
- [4] Miltiadis Allamanis, Henry Jackson-Flux, and Marc Brockschmidt. 2021. Self-supervised bug detection and repair. *Advances in Neural Information Processing Systems* 34 (2021), 27865–27876.
- [5] Lorena Arcega, Jaime Font, Øystein Haugen, and Carlos Cetina. 2021. Bug Localization in Model-Based Systems in the Wild. *ACM Trans. Softw. Eng. Methodol.* 31, 1, Article 10 (oct 2021), 32 pages. <https://doi.org/10.1145/3472616>
- [6] Andrea Arcuri, Man Zhang, and Juan Pablo Galeotti. 2024. Advanced White-Box Heuristics for Search-Based Fuzzing of REST APIs. *ACM Trans. Softw. Eng. Methodol.* (mar 2024). <https://doi.org/10.1145/3652157> Just Accepted.
- [7] Nathaniel Ayewah, William Pugh, David Hovemeyer, J. David Morgenthaler, and John Penix. 2008. Using Static Analysis to Find Bugs. *IEEE Software* 25, 5 (2008), 22–29. <https://doi.org/10.1109/MS.2008.130>
- [8] Vipin Balachandran. 2013. Reducing human effort and improving quality in peer code reviews using automatic static analysis and reviewer recommendation. In *2013 35th International Conference on Software Engineering (ICSE)*. 931–940. <https://doi.org/10.1109/ICSE.2013.6606642>
- [9] Pavol Bielik, Veselin Raychev, and Martin Vechev. 2017. Learning a static analyzer from data. In *Computer Aided Verification: 29th International Conference, CAV 2017, Heidelberg, Germany, July 24–28, 2017, Proceedings, Part I 30*. Springer, 233–253.
- [10] Peter F Brown, Vincent J Della Pietra, Peter V Desouza, Jennifer C Lai, and Robert L Mercer. 1992. Class-based n-gram models of natural language. *Computational linguistics* 18, 4 (1992), 467–480.
- [11] Cristiano Calcagno, Dino Distefano, Jeremy Dubreil, Dominik Gabi, Pieter Hooimeijer, Martino Luca, Peter O’Hearn, Irene Papakonstantinou, Jim Purbrick, and Dulma Rodriguez. 2015. Moving Fast with Software Verification. In *NASA Formal Methods*, Klaus Havelund, Gerard Holzmann, and Rajeev Joshi (Eds.). Springer International Publishing, Cham, 3–11. https://doi.org/10.1007/978-3-319-17524-9_1
- [12] Yiu Wai Chow, Max Schäfer, and Michael Pradel. 2023. Beware of the Unexpected: Bimodal Taint Analysis. In *Proceedings of the 32nd ACM SIGSOFT International Symposium on Software Testing and Analysis (Seattle, WA, USA.) (ISSTA 2023)*. Association for Computing Machinery, New York, NY, USA, 211–222. <https://doi.org/10.1145/3597926.3598050>
- [13] Christoph Csallner and Yannis Smaragdakis. 2005. Check’n’Crash: Combining static checking and testing. In *Proceedings of the 27th international conference on Software engineering*. 422–431.
- [14] Mohan Cui, Chengjun Chen, Hui Xu, and Yangfan Zhou. 2023. SafeDrop: Detecting Memory Deallocation Bugs of Rust Programs via Static Data-flow Analysis. *ACM Trans. Softw. Eng. Methodol.* 32, 4, Article 82 (may 2023), 21 pages. <https://doi.org/10.1145/3542948>
- [15] Jayati Deshmukh, K. M. Annervaz, Sanjay Podder, Shubhashis Sengupta, and Neville Dubash. 2017. Towards Accurate Duplicate Bug Retrieval Using Deep Learning Techniques. In *2017 IEEE International Conference on Software Maintenance and Evolution (ICSME)*. 115–124. <https://doi.org/10.1109/ICSME.2017.69>
- [16] Zhangyin Feng, Daya Guo, Duyu Tang, Nan Duan, Xiaocheng Feng, Ming Gong, Linjun Shou, Bing Qin, Ting Liu, Daxin Jiang, et al. 2020. Codebert: A pre-trained model for programming and natural languages. *arXiv preprint arXiv:2002.08155* (2020).
- [17] Daya Guo, Shuo Ren, Shuai Lu, Zhangyin Feng, Duyu Tang, Shujie Liu, Long Zhou, Nan Duan, Alexey Svyatkovskiy, Shengyu Fu, et al. 2020. Graphcodebert: Pre-training code representations with data flow. *arXiv preprint arXiv:2009.08366* (2020).
- [18] Lan-Zhe Guo and Yu-Feng Li. 2022. Class-Imbalanced Semi-Supervised Learning with Adaptive Thresholding. In *Proceedings of the 39th International Conference on Machine Learning (Proceedings of Machine Learning Research, Vol. 162)*, Kamalika Chaudhuri, Stefanie Jegelka, Le Song, Csaba Szepesvari, Gang Niu, and Sivan Sabato (Eds.). PMLR, 8082–8094. <https://proceedings.mlr.press/v162/guo22e.html>
- [19] Liu Han, Chen Sen, Feng Ruitao, Liu Chengwei, Li Kaixuan, Xu Zhengzi, Nie Liming, Liu Yang, and Chen Yixiang. 2023. A Comprehensive Study on Quality Assurance Tools for Java. In *Proceedings of the 32st ACM SIGSOFT International Symposium on Software Testing and Analysis (Seattle, United States) (ISSTA 2023)*. Association for Computing Machinery, New York, NY, USA, 13 pages. <https://doi.org/10.1145/3597926.3598056>
- [20] Quinn Hanam, Lin Tan, Reid Holmes, and Patrick Lam. 2014. Finding Patterns in Static Analysis Alerts: Improving Actionable Alert Ranking. In *Proceedings of the 11th Working Conference on Mining Software Repositories (Hyderabad, India) (MSR 2014)*. Association for Computing Machinery, New York, NY, USA, 152–161. <https://doi.org/10.1145/2597073.2597100>
- [21] Ahmed E. Hassan. 2008. Automated Classification of Change Messages in Open Source Projects. In *Proceedings of the 2008 ACM Symposium on Applied Computing (Fortaleza, Ceara, Brazil) (SAC ’08)*. Association for Computing Machinery, New York, NY, USA, 837–841. <https://doi.org/10.1145/1363686.1363876>
- [22] Sarah Heckman and Laurie Williams. 2009. A Model Building Process for Identifying Actionable Static Analysis Alerts. In *2009 International Conference on Software Testing Verification and Validation*. 161–170. <https://doi.org/10.1109/ICST.2009.45>
- [23] Sarah Heckman and Laurie Williams. 2011. A systematic literature review of actionable alert identification techniques for automated static code analysis. *Information and Software Technology* 53, 4 (2011), 363–387. <https://doi.org/10.1016/j.infsof.2010.12.007> Special section: Software Engineering track of the 24th Annual Symposium on Applied Computing.

- [24] David Hovemeyer and William Pugh. 2004. Finding Bugs is Easy. *SIGPLAN Not.* 39, 12 (dec 2004), 92–106. <https://doi.org/10.1145/1052883.1052895>
- [25] Brittany Johnson, Yoonki Song, Emerson Murphy-Hill, and Robert Bowdidge. 2013. Why don't software developers use static analysis tools to find bugs?. In *2013 35th International Conference on Software Engineering (ICSE)*. 672–681. <https://doi.org/10.1109/ICSE.2013.6606613>
- [26] Maximilian Junker, Ralf Huuck, Ansgar Fehnker, and Alexander Knapp. 2012. SMT-Based False Positive Elimination in Static Program Analysis. In *Formal Methods and Software Engineering*, Toshiaki Aoki and Kenji Taguchi (Eds.). Springer Berlin Heidelberg, Berlin, Heidelberg, 316–331.
- [27] Hong Jin Kang, Khai Loong Aw, and David Lo. 2022. Detecting False Alarms from Automatic Static Analysis Tools: How Far Are We?. In *Proceedings of the 44th International Conference on Software Engineering (Pittsburgh, Pennsylvania) (ICSE '22)*. Association for Computing Machinery, New York, NY, USA, 698–709. <https://doi.org/10.1145/3510003.3510214>
- [28] Anant Kharkar, Roshanak Zilouchian Moghaddam, Matthew Jin, Xiaoyu Liu, Xin Shi, Colin Clement, and Neel Sundaresan. 2022. Learning to Reduce False Positives in Analytic Bug Detectors. In *Proceedings of the 44th International Conference on Software Engineering (Pittsburgh, Pennsylvania) (ICSE '22)*. Association for Computing Machinery, New York, NY, USA, 1307–1316. <https://doi.org/10.1145/3510003.3510153>
- [29] Sunghun Kim and Michael D. Ernst. 2007. Prioritizing Warning Categories by Analyzing Software History. In *Fourth International Workshop on Mining Software Repositories (MSR'07:ICSE Workshops 2007)*. 27–27. <https://doi.org/10.1109/MSR.2007.26>
- [30] Sunghun Kim and Michael D. Ernst. 2007. Which Warnings Should I Fix First?. In *Proceedings of the the 6th Joint Meeting of the European Software Engineering Conference and the ACM SIGSOFT Symposium on The Foundations of Software Engineering (Dubrovnik, Croatia) (ESEC-FSE '07)*. Association for Computing Machinery, New York, NY, USA, 45–54. <https://doi.org/10.1145/1287624.1287633>
- [31] Diederik P. Kingma and Jimmy Ba. 2017. Adam: A Method for Stochastic Optimization. arXiv:1412.6980 [cs.LG]
- [32] Ugur Koc, Shiyi Wei, Jeffrey S. Foster, Marine Carpuat, and Adam A. Porter. 2019. An Empirical Assessment of Machine Learning Approaches for Triaging Reports of a Java Static Analysis Tool. In *2019 12th IEEE Conference on Software Testing, Validation and Verification (ICST)*. 288–299. <https://doi.org/10.1109/ICST.2019.00036>
- [33] Kaituo Li, Christoph Reichenbach, Christoph Csallner, and Yannis Smaragdakis. 2014. Residual investigation: Predictive and precise bug detection. *ACM Transactions on Software Engineering and Methodology (TOSEM)* 24, 2 (2014), 1–32.
- [34] Zhen Li, Deqing Zou, Shouhuai Xu, Xinyu Ou, Hai Jin, Sujuan Wang, Zhijun Deng, and Yuyi Zhong. 2018. Vuldeepecker: A deep learning-based system for vulnerability detection. *arXiv preprint arXiv:1801.01681* (2018).
- [35] Guangtai Liang, Ling Wu, Qian Wu, Qianxiang Wang, Tao Xie, and Hong Mei. 2010. Automatic Construction of an Effective Training Set for Prioritizing Static Analysis Warnings. In *Proceedings of the 25th IEEE/ACM International Conference on Automated Software Engineering (Antwerp, Belgium) (ASE '10)*. Association for Computing Machinery, New York, NY, USA, 93–102. <https://doi.org/10.1145/1858996.1859013>
- [36] Tsung-Yi Lin, Priya Goyal, Ross Girshick, Kaiming He, and Piotr Dollár. 2018. Focal Loss for Dense Object Detection. arXiv:1708.02002 [cs.CV]
- [37] Bailin Lu, Wei Dong, Liangze Yin, and Li Zhang. 2018. Evaluating and Integrating Diverse Bug Finders for Effective Program Analysis. In *Software Analysis, Testing, and Evolution*, Lei Bu and Yingfei Xiong (Eds.). Vol. 11293. Springer International Publishing, Cham, 51–67. https://doi.org/10.1007/978-3-030-04272-1_4 Series Title: Lecture Notes in Computer Science.
- [38] Thu-Trang Nguyen, Toshiaki Aoki, Takashi Tomita, and Iori Yamada. 2019. Multiple program analysis techniques enable precise check for SEI CERT C coding standard. In *2019 26th Asia-Pacific Software Engineering Conference (APSEC)*. IEEE, 70–77.
- [39] Thu Trang Nguyen, Pattaravut Maleehuan, Toshiaki Aoki, Takashi Tomita, and Iori Yamada. 2019. Reducing false positives of static analysis for sei cert c coding standard. In *2019 IEEE/ACM Joint 7th International Workshop on Conducting Empirical Studies in Industry (CESI) and 6th International Workshop on Software Engineering Research and Industrial Practice (SER&IP)*. IEEE, 41–48.
- [40] Chao Ni, Kaiwen Yang, Xin Xia, David Lo, Xiang Chen, and Xiaohu Yang. 2022. Defect Identification, Categorization, and Repair: Better Together. arXiv:2204.04856 [cs.SE]
- [41] Amin Nikanjam, Housseem Ben Braiek, Mohammad Mehdi Morovati, and Foutse Khomh. 2021. Automatic Fault Detection for Deep Learning Programs Using Graph Transformations. *ACM Trans. Softw. Eng. Methodol.* 31, 1, Article 14 (sep 2021), 27 pages. <https://doi.org/10.1145/3470006>
- [42] Oracle. 2022. Oracle Java Documentation. <https://docs.oracle.com/javase/tutorial/java/javaOO/variables.html>. (Accessed on 01/12/2023).
- [43] Sebastiano Panichella, Venera Arnaoudova, Massimiliano Di Penta, and Giuliano Antoniol. 2015. Would static analysis tools help developers with code reviews?. In *2015 IEEE 22nd International Conference on Software Analysis, Evolution, and Reengineering (SANER)*. 161–170. <https://doi.org/10.1109/SANER.2015.7081826>
- [44] Terence Parr and Sam Harwell. 2020. ANTLR 4. <https://www.antlr.org/>. (Accessed on 01/12/2023).
- [45] Maria Perez-Ortiz, P Tiño, Rafal Mantiuk, and César Hervás-Martínez. 2019. Exploiting synthetically generated data with semi-supervised learning for small and imbalanced datasets. In *Proceedings of the AAAI Conference on Artificial Intelligence*, Vol. 33. 4715–4722.
- [46] Chanathip Pornprasit and Chakkrit Kla Tantithamthavorn. 2022. Deeplinedp: Towards a deep learning approach for line-level defect prediction. *IEEE Transactions on Software Engineering* 49, 1 (2022), 84–98.
- [47] Juan Ramos et al. 2003. Using tf-idf to determine word relevance in document queries. In *Proceedings of the first instructional conference on machine learning*, Vol. 242. Citeseer, 29–48.
- [48] Xavier Rival. 2005. Abstract dependences for alarm diagnosis. In *Programming Languages and Systems: Third Asian Symposium, APLAS 2005, Tsukuba, Japan, November 2-5, 2005. Proceedings 3*. Springer, 347–363.
- [49] Xavier Rival. 2005. Understanding the origin of alarms in Astrée. In *Static Analysis: 12th International Symposium, SAS 2005, London, UK, September 7-9, 2005. Proceedings 12*. Springer, 303–319.

- [50] Joseph R. Ruthruff, John Penix, J. David Morgenthaler, Sebastian Elbaum, and Gregg Rothermel. 2008. Predicting Accurate and Actionable Static Analysis Warnings: An Experimental Approach. In *Proceedings of the 30th International Conference on Software Engineering (Leipzig, Germany) (ICSE '08)*. Association for Computing Machinery, New York, NY, USA, 341–350. <https://doi.org/10.1145/1368088.1368135>
- [51] Caitlin Sadowski, Jeffrey Van Gogh, Ciera Jaspan, Emma Soderberg, and Collin Winter. 2015. Tricorder: Building a program analysis ecosystem. In *2015 IEEE/ACM 37th IEEE International Conference on Software Engineering*, Vol. 1. IEEE, 598–608.
- [52] M. Schuster and K.K. Paliwal. 1997. Bidirectional recurrent neural networks. *IEEE Transactions on Signal Processing* 45, 11 (1997), 2673–2681. <https://doi.org/10.1109/78.650093>
- [53] SonarSource. 2022. Sonarqube. <https://www.sonarqube.org> (Accessed on 01/12/2023).
- [54] Spotbugs. 2022. Spotbugs. <https://spotbugs.github.io> (Accessed on 01/12/2023).
- [55] David A. Tomassi. 2018. Bugs in the wild: examining the effectiveness of static analyzers at finding real-world bugs. In *Proceedings of the 2018 26th ACM Joint Meeting on European Software Engineering Conference and Symposium on the Foundations of Software Engineering*. ACM, Lake Buena Vista FL USA, 980–982. <https://doi.org/10.1145/3236024.3275439>
- [56] Huy Tu and Tim Menzies. 2021. FRUGAL: Unlocking Semi-Supervised Learning for Software Analytics. In *2021 36th IEEE/ACM International Conference on Automated Software Engineering (ASE)*. 394–406. <https://doi.org/10.1109/ASE51524.2021.9678617>
- [57] Kristín Fjóra Tómasdóttir, Mauricio Aniche, and Arie van Deursen. 2017. Why and how JavaScript developers use linters. In *2017 32nd IEEE/ACM International Conference on Automated Software Engineering (ASE)*. 578–589. <https://doi.org/10.1109/ASE.2017.8115668>
- [58] Carmine Vassallo, Sebastiano Panichella, Fabio Palomba, Sebastian Proksch, Harald C Gall, and Andy Zaidman. 2020. How developers engage with static analysis tools in different contexts. *Empirical Software Engineering* 25 (2020), 1419–1457.
- [59] Ashish Vaswani, Noam Shazeer, Niki Parmar, Jakob Uszkoreit, Llion Jones, Aidan N Gomez, Lukasz Kaiser, and Illia Polosukhin. 2017. Attention is all you need. *Advances in neural information processing systems* 30 (2017).
- [60] Chengpeng Wang, Wenyang Wang, Peisen Yao, Qingkai Shi, Jinguo Zhou, Xiao Xiao, and Charles Zhang. 2023. Anchor: Fast and Precise Value-flow Analysis for Containers via Memory Orientation. *ACM Trans. Softw. Eng. Methodol.* 32, 3, Article 66 (apr 2023), 39 pages. <https://doi.org/10.1145/3565800>
- [61] Junjie Wang, Song Wang, and Qing Wang. 2018. Is There a "Golden" Feature Set for Static Warning Identification? An Experimental Evaluation. In *Proceedings of the 12th ACM/IEEE International Symposium on Empirical Software Engineering and Measurement (Oulu, Finland) (ESEM '18)*. Association for Computing Machinery, New York, NY, USA, Article 17, 10 pages. <https://doi.org/10.1145/3239235.3239523>
- [62] C.C. Williams and J.K. Hollingsworth. 2005. Automatic mining of source code repositories to improve bug finding techniques. *IEEE Transactions on Software Engineering* 31, 6 (2005), 466–480. <https://doi.org/10.1109/TSE.2005.63>
- [63] Hongjun Wu, Zhuo Zhang, Shangwen Wang, Yan Lei, Bo Lin, Yihao Qin, Haoyu Zhang, and Xiaoguang Mao. 2021. Peculiar: Smart contract vulnerability detection based on crucial data flow graph and pre-training techniques. In *2021 IEEE 32nd International Symposium on Software Reliability Engineering (ISSRE)*. IEEE, 378–389.
- [64] Wei-Cheng Wu, Bernard Nongpoh, Marwan Nour, Michaël Marozzi, Sébastien Bardin, and Christophe Hauser. 2023. Fine-Grained Coverage-Based Fuzzing. *ACM Trans. Softw. Eng. Methodol.* (mar 2023). <https://doi.org/10.1145/3587158> Just Accepted.
- [65] Xueqi Yang, Jianfeng Chen, Rahul Yedida, Zhe Yu, and Tim Menzies. 2021. Learning to Recognize Actionable Static Code Warnings (is Intrinsically Easy). *Empirical Softw. Engg.* 26, 3 (may 2021), 24 pages. <https://doi.org/10.1007/s10664-021-09948-6>
- [66] Yuzhe Yang and Zhi Xu. 2020. Rethinking the Value of Labels for Improving Class-Imbalanced Learning. In *Conference on Neural Information Processing Systems (NeurIPS)*.
- [67] Ulas Yüksel and Hasan Sözer. 2013. Automated Classification of Static Code Analysis Alerts: A Case Study. In *2013 IEEE International Conference on Software Maintenance*. 532–535. <https://doi.org/10.1109/ICSM.2013.89>
- [68] Wojciech Zaremba and Ilya Sutskever. 2015. Learning to Execute. arXiv:1410.4615 [cs.NE]
- [69] Cen Zhang, Xingwei Lin, Yuekang Li, Yinxiang Xue, Jundong Xie, Hongxu Chen, Xinlei Ying, Jiashui Wang, and Yang Liu. 2021. APICraft: Fuzz Driver Generation for Closed-source SDK Libraries. In *30th USENIX Security Symposium, USENIX Security 2021, August 11-13, 2021*, Michael Bailey and Rachel Greenstadt (Eds.). USENIX Association, 2811–2828. <https://www.usenix.org/conference/usenixsecurity21/presentation/zhang-cen>
- [70] Jian Zhang, Xu Wang, Hongyu Zhang, Hailong Sun, Kaixuan Wang, and Xudong Liu. 2019. A Novel Neural Source Code Representation Based on Abstract Syntax Tree. In *2019 IEEE/ACM 41st International Conference on Software Engineering (ICSE)*. 783–794. <https://doi.org/10.1109/ICSE.2019.00086>
- [71] Deqing Zou, Sujuan Wang, Shouhuai Xu, Zhen Li, and Hai Jin. 2021. VulDeePecker: A Deep Learning-Based System for Multiclass Vulnerability Detection. *IEEE Transactions on Dependable and Secure Computing* 18, 5 (2021), 2224–2236. <https://doi.org/10.1109/TDSC.2019.2942930>