

Privacy Preserving Decision Tree Training and Prediction via Fully Homomorphic Encryption with No Decryption

Hunjae Lee
Computer Science
Southern Methodist University

Corey Clark
Computer Science
Guildhall
Southern Methodist University

Abstract

With data-outsourcing becoming commonplace, there grows a need for secure outsourcing of data and machine learning models. Namely, data and model owners (client) often have a need for their information to remain private and secure against the potentially untrusted computing resource (server) to whom they want to outsource said data and models to. Various approaches to privacy-preserving machine learning (PPML) have been devised with different techniques and solutions introduced in the past. These solutions often involved one of two compromises: (1) client-server interactions to allow intermediary rounds of decryption and re-encryption of data or (2) complex architectures for multi-party computation. This paper devises a paradigm using Fully Homomorphic Encryption (FHE) that minimizes architectural complexity and removes client-side involvement during the training and prediction lifecycle of machine learning models. In addition, the paradigm proposed in this work achieves both model security as well as data security. To remove client-side involvement, the devised paradigm proposes a *no decryption* approach that allows the server to handle PPML in its entirety without rounds of decryption and re-encryption. To the best of our knowledge, this paradigm is the first to achieve privacy-preserving decision tree training with *no decryption* while maintaining a simple client-server architecture.

1 Introduction

Using decision trees as the model of choice, this work introduces a paradigm for performing privacy preserving machine learning (PPML) training and inference using Fully Homomorphic Encryption (FHE). FHE allows for computation on encrypted data without the need for decrypting it first [10]. This property of FHE includes arithmetic operations such as addition and multiplication and can extend to polynomial functions. However, FHE is not without its limitations. Namely, there is significant asymmetry between the advancement of machine learning and what machine learning with

FHE is capable of in its current state. Often, compromises have to be made to allow FHE to be compatible with a given machine learning architecture. These compromises include polynomial approximation of non-polynomial functions [19], using lookup tables [4] [16], and interaction protocols between client (data owners) and server (untrusted entity where all computation is done with FHE) to allow for some computation to be done on client-side with unencrypted, plaintext data [1] [12].

Decision trees are used as the machine learning model of choice in this work because they can be utilized in a diverse array of tasks. Furthermore, decision trees offer a great starting point for further machine learning research with FHE such as with random forests and even with neural networks as neural networks can be represented as decision trees [3]. The paradigm proposed in this work minimizes architectural complexity and removes client-side involvement. This privacy-preserving paradigm is devised such that the client can be offline as soon as encrypted data are sent to the server. The server then trains the decision tree model with both data and model privacy without interaction with the client or any other service. The fully trained privacy-preserving decision tree can then perform inference tasks on the server as is or be sent back to the client.

2 Related Work

There have been much progress made in the field of PPML and FHE in the last twenty years. Prior works [13], [14] constructed privacy-preserving logistic regression models using FHE with polynomial approximation of activation functions. Cryptonets [11] opened the door for neural network evaluation (inference/prediction) by successfully adopting FHE into the inference process of an already trained neural network. Later, Hesamifard et al. introduced CryptoDL [12], a framework that allows training and evaluation of deep neural networks with client-server interaction for noise reduction. Using TFHE (or FHE over the torus) [6], results indicating the feasibility of deep neural network inference with FHE were

shown [7]. The work from [7] uses *programmable bootstrapping* as part of their FHE scheme as opposed to *leveled mode* like others mentioned above. Using FHE with *leveled mode* allows for faster computation compared to *bootstrapped mode* but can only compute a predetermined number of products. This poses a problem with respect to scalability of models. On the other hand, FHE with *bootstrapped mode* enables noise reduction whenever noise reaches a certain threshold, allowing for evaluation of complex circuits and functions. It is this *programmable bootstrapping* technique that is used in this paper.

Concerning decision trees, the first attempt at privacy-preserving decision tree training involved secure multi-party computation [17]. The following prior works [8], [9] also considered multi-party computation techniques for decision tree learning. A method for training and inferring decision trees with a twin-cloud architecture using additive secret sharing was also explored in [18]. These approaches generally involve two or more parties adhering to strict security and privacy standards and can be made vulnerable if one or more participating parties collude with each other or break their security parameters. A simple client-server model where a bulk of privacy-preserving computations with FHE are conducted on the server was demonstrated in [1]. This approach greatly minimizes architectural complexity of the model when compared to prior works that employed multi-party computation. [1] also uses a client-server architecture similar to one employed in this work. However, the training protocol from [1] requires d -rounds of communication between client and server for tree depth of d where each round of communication with the client entails decryption and re-encryption of data to allow some computation to be handled in plaintext on client-side.

3 Preliminaries

This section goes over the terminology and concepts used in the process of actualizing the *no decryption* paradigm proposed in this work. Many of these concepts take advantage of bitwise properties of Boolean FHE and thus not applicable in other FHE schemas such as the CKKS scheme which uses floating-point arithmetic [5].

3.1 Fully Homomorphic Encryption

Mathematical proofs and definitions for FHE and relevant cryptographic functions from [10] are shown below.

A homomorphic encryption scheme \mathcal{E} is equipped with algorithms $KeyGen_{\mathcal{E}}$, $Encrypt_{\mathcal{E}}$, $Decrypt_{\mathcal{E}}$, and $Evaluate_{\mathcal{E}}$. In addition, the computational complexity of all of these algorithms must be polynomial in security parameter λ .

The inputs to this scheme are: public key pk , a circuit C from a permitted set $C_{\mathcal{E}}$ of circuits, and a tuple of ciphertexts $\Psi = \langle \psi_1, \dots, \psi_t \rangle$.

\mathcal{E} is correct for circuits in $C_{\mathcal{E}}$ if, for any key-pair (sk, pk) output by $KeyGen_{\mathcal{E}}(\lambda)$, any circuit $C \in C_{\mathcal{E}}$, any plaintexts π_1, \dots, π_t , and any ciphertexts $\Psi = \langle \psi_1, \dots, \psi_t \rangle$ with $\psi_i \leftarrow Encrypt_{\mathcal{E}}(pk, \pi_i)$, it is the case that:

$$\Psi \leftarrow Evaluate_{\mathcal{E}}(pk, C, \Psi) \Rightarrow C(\pi_1, \dots, \pi_t) = Decrypt_{\mathcal{E}}(sk, \Psi)$$

Formal definition for homomorphic encryption is as following: \mathcal{E} is homomorphic for circuits in $C_{\mathcal{E}}$ if \mathcal{E} is correct for $C_{\mathcal{E}}$ and $Decrypt_{\mathcal{E}}$ can be expressed as a circuit $D_{\mathcal{E}}$ of size $poly(\lambda)$. Furthermore, \mathcal{E} is fully homomorphic if it is homomorphic for all circuits.

3.2 FHE over the Boolean

In this work, we use a Boolean FHE scheme called TFHE, or FHE over the Torus [6]. Boolean FHE is a form of FHE that supports bitwise logical operations such as bitwise union and intersection. In addition, Boolean FHE offers a great degree of flexibility allowing for arithmetic as well as complicated logical operations to be constructed with Boolean circuits that are incompatible with integer or floating-point FHE schemes. These properties are necessary to establish a paradigm where the entirety of decision tree training and inference are conducted without any round of decryption. This does not mean that integer and floating-point data cannot be used with Boolean FHE, however. Integer or floating-point datatypes can be converted to binary representations to be used in this paradigm.

3.3 Boolean Circuits for logical and arithmetic operations

Boolean FHE supports bitwise AND (union), OR (intersection), and NOT (negation). Arithmetic operations like addition, multiplication, and even division can be represented with Boolean circuits with combinations of these three gates. Likewise, logical operations such as comparisons can also be represented with Boolean circuits. Prior works [2] and [20] outline ways of constructing two-bit and four-bit comparison circuits in digital logic, respectively. In other words, for given inputs A and B where both A and B are n bits long, a comparison circuit produces an output γ where γ is a one-bit Boolean indicator denoted 1 if A is greater than B and 0 if B is greater than A . Figure 1 shows full digital logic of a four-bit comparison circuit that also accounts for input equality.

With Boolean FHE, these Boolean circuits can be constructed and used with encrypted data, returning encrypted results. In many prior works, comparisons necessary for decision tree training such as with feature selection and threshold calculation were first sent back to the client to be decrypted and computed in plaintext [1]. The results of those comparisons would then be re-encrypted and sent back to the server for fur-

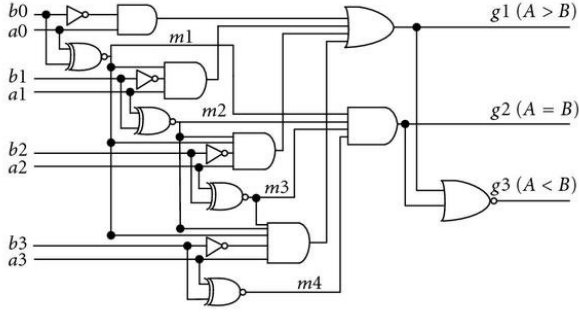

Figure 1: Digital Logic of 4-bit Comparator [21]

ther training. However, with a comparison circuit constructed with Boolean FHE, any comparison operation can be done in FHE space without decryption and re-encryption. The results of those comparisons are encrypted and thus do not violate any cryptographic principles, nor do they leak information about the inputs to the circuit. Because outputs of any circuit with Boolean FHE are encrypted, they cannot be evaluated directly and thus require blind evaluations such as in Equation 3.

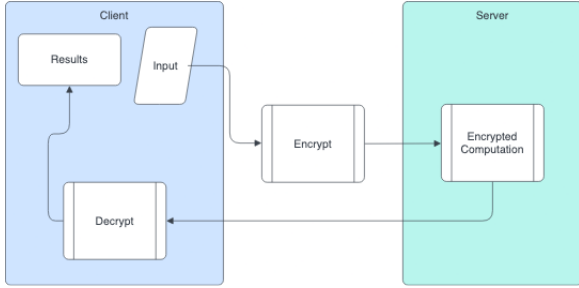

Figure 2: client-server architecture in FHE

3.4 Terminology

1. **Client:** Refers to the entity that possesses the private key of the encryption scheme, and has the authority to encrypt/decrypt data. The client is typically the data owners.
2. **Server:** Refers to computing entity that is unsecured and potentially malicious to whom encrypted data is outsourced. The server can perform arithmetic and logical operations on encrypted data with FHE such as decision tree training and inference. The server does not have access to the private key and therefore cannot decrypt or gain information from the data outsourced by the client. All server-side computations and operations are done without compromising the security and privacy of both the data and model.

3. **FHE accessible:** A particular variable/vector/matrix that is encrypted with FHE so that it can be used in encrypted bitwise operations with other encrypted data. Results of FHE evaluations are FHE accessible. Note that many Boolean FHE schemas only support bitwise operations between encrypted data and therefore it may not be possible to perform bitwise operations between ciphertext and plaintext.

3.5 Algorithmic Concepts

1. **Blind Comparison:** Refers to performing a comparison operation wherein inputs, results, and any intermediary data are unknown to the computing entity (i.e., the server) due to FHE. This is only made possible with Boolean FHE schemas as comparison circuits can be assembled using only primitive bitwise logical operators as shown below.

$$A > B \leftarrow A \wedge \neg B \quad (1)$$

$$A < B \leftarrow \neg A \wedge B$$

$$A = B \leftarrow (\neg A \wedge \neg B) \vee (A \wedge B)$$

Algorithm 1 Bitwise Blind Comparison

- 1: **gt** is 1 if $A > B$, 0 otherwise
 - 2: **lt** is 1 if $A < B$, 0 otherwise
 - 3: **procedure** BITWISEBLINDCOMPARISON($\mathcal{E}(A)$, $\mathcal{E}(B)$)
 - 4: $\mathcal{E}(gt) \leftarrow \mathcal{E}(A) \wedge \neg \mathcal{E}(B)$
 - 5: $\mathcal{E}(lt) \leftarrow \neg \mathcal{E}(A) \wedge \mathcal{E}(B)$
 - 6: **return** $\mathcal{E}(gt)$, $\mathcal{E}(lt)$
 - 7: **end procedure**
-

Blind comparisons preserve the cryptographic integrity of FHE since the results of comparisons remain encrypted with no way to evaluate any information from said results. Because outputs of blind comparisons are encrypted, they are FHE accessible. Programmatic paradigms can be established to make use of the outputs from blind comparisons without directly evaluating them.

2. **Collapsing:** Because results from blind comparisons are encrypted and their values cannot be inferred, conditional branching cannot be performed in a traditional sense. However, conditional branching can be simulated by executing all branches of a given condition and nullifying the results of all but the one branch that is correct. This can be achieved by chaining together the results of blind comparisons with desired branch operations using bitwise AND, resulting in the wrong branches collapsing to 0 while the correct branch retains its values.

Algorithm 2 Example of Conditional Branching

```
1: Input: A, B, X
2: Output: X modified based on comparison result
3:
4: if A > B then
5:   X ← X + 1
6: else
7:   X ← X - 1
8: end if
```

A polynomial equation representation of Algorithm 2 is shown below in Equation 2. Equation 3 is a modification of Equation 2 that uses FHE encrypted data using Algorithm 1 returning an encrypted result.

$$X \leftarrow X + (1 \times (A > B) + (-1 \times (B > A))) \quad (2)$$

$$\mathcal{E}(X) \leftarrow \mathcal{E}(X) + (1 \wedge \text{BLINDCOMPARISON}(\mathcal{E}(A), \mathcal{E}(B))) - (1 \wedge \text{BLINDCOMPARISON}(\mathcal{E}(B), \mathcal{E}(A))) \quad (3)$$

Because the evaluation of Equation 3 happens in FHE mode, there is no way to evaluate or even know which branches collapsed and which ones did not until the client uses the private key to decrypt the results.

3. Blind Swapping: Using blind comparison and bit manipulation techniques, one can swap two elements in a list in ascending or descending order. Note that this is done purely with bit manipulation using outputs of blind comparisons and thus does not give away any information about the data. Equation 4 demonstrates a blind swap of two one-bit values α and β in a list. Both α and β are modified in place during the swap meaning the resulting α may contain the value of β and vice versa. It is also true that their values may remain unchanged after the swap depending on the comparison result. Equation 5 is a modification of Equation 4 that allows swapping on multi-bit values. Blind swapping can also be used in iteration in a list, allowing for min/max calculations.

$$\begin{aligned} \mathcal{E}(gt), \mathcal{E}(lt) &= \text{BITWISEBLINDCOMPARISON}(\mathcal{E}(\alpha), \mathcal{E}(\beta)) \\ \mathcal{E}(\alpha) &= (\mathcal{E}(lt) \wedge \mathcal{E}(\beta)) \vee (\mathcal{E}(gt) \wedge \mathcal{E}(\alpha)) \\ \mathcal{E}(\beta) &= (\mathcal{E}(lt) \wedge \mathcal{E}(\alpha)) \vee (\mathcal{E}(gt) \wedge \mathcal{E}(\beta)) \end{aligned} \quad (4)$$

$$\begin{aligned} \mathcal{E}(gt), \mathcal{E}(lt) &= \text{BLINDCOMPARISON}(\mathcal{E}(\mathcal{A}), \mathcal{E}(\mathcal{B})) \\ \mathcal{E}(\mathcal{A}) &= (\mathcal{E}(lt) \wedge \mathcal{E}(\mathcal{B}_{1..n})) \vee (\mathcal{E}(gt) \wedge \mathcal{E}(\mathcal{A}_{1..n})) \\ \mathcal{E}(\mathcal{B}) &= (\mathcal{E}(lt) \wedge \mathcal{E}(\mathcal{A}_{1..n})) \vee (\mathcal{E}(gt) \wedge \mathcal{E}(\mathcal{B}_{1..n})) \end{aligned} \quad (5)$$

Algorithm 3 blind swapping

```
1: Output from blind comparison:  $\mathcal{E}(gt), \mathcal{E}(lt)$ 
2: Input: array[ $\mathcal{E}(A), \mathcal{E}(B)$ ] where both A and B are 4-bit binary numbers
3: Output: array[ $\mathcal{E}(?), \mathcal{E}(?)$ ]
4:
5: procedure BLINDSWAPPING(array)
6:    $\mathcal{E}(gt), \mathcal{E}(lt) = \text{BLINDCOMPARISON}(\mathcal{E}(A), \mathcal{E}(B))$ 
7:   for  $i \leftarrow 0$  to  $n$  do
8:     array[0][ $i$ ] =  $(\mathcal{E}(lt) \wedge \text{array}[1][i]) \vee (\mathcal{E}(gt) \wedge \text{array}[0][i])$ 
9:     array[1][ $i$ ] =  $(\mathcal{E}(lt)) \vee (\mathcal{E}(gt) \wedge \text{array}[1][i])$ 
10:  end for
11:
12:  return array
13: end procedure
```

4. Blind Sorting: Using blind comparisons and blind swapping techniques, a modified version of insertion sort algorithm can be assembled to sort an entire list of FHE data. Because conditional branching cannot be used on FHE values, all loops must be completely unrolled. Therefore, blind sorting will always perform the insertion sort equivalent of worst-case time-complexity. A simple version of blind sorting implementation is shown in Algorithm 4. Because there is no way to know if array[$j - 1$] is greater than or equal to array[j] in line 5, blind swapping has to be performed with every element pair at each iteration.

Algorithm 4 Blind Sorting

```
1: procedure BLINDSORTING(array)
2:   for  $i$  in  $0..array.length$  do
3:      $j = i$ 
4:     while  $j > 0$  do
5:       BLINDSWAPPING(array[ $j - 1$ ], array[ $j$ ])
6:        $j = j - 1$ 
7:     end while
8:   end for
9: end procedure
```

3.6 Decision Tree Training and Prediction

A decision tree is a tree that recursively partitions a given dataset based on input features and their corresponding labels in order to maximize classification or regression performance. Nodes of a decision tree and their corresponding partitions of data are often learned to fit the given dataset. As a result, decision trees are prone to overfitting. A simple outline for a decision tree training procedure is shown in Algorithm 5. Evaluation, or prediction, in a trained decision tree given an input x is performed by traversing the tree starting from root, using the partitioning rule at each node to select the

correct path at each level until a leaf node is reached. The specific label from the leaf node is then returned as the result. A simple outline for a decision tree evaluation protocol is shown in Algorithm 6

Algorithm 5 Decision Tree Training

```

1: X: feature data where  $X^i$  refers to column data
2: y: class labels
3: procedure TRAINDECISIONTREE(X, y)
4:   if all X belong to the same class then
5:     return a leaf node with that class label
6:   end if
7:   if  $X^i$  is empty then
8:     return a leaf node with the majority class label
      among remaining examples
9:   end if
10:  Choose the  $X^i$   $i$  that best splits the examples
11:  Create a new decision tree node  $N$  with attribute  $i$ 
12:  for all possible value  $V$  of attribute  $i$  do
13:     $X_v \leftarrow$  subset of examples where attribute  $i$  has
      value  $V$ 
14:    if  $X_v$  is empty then
15:      Attach a leaf node with the majority class label
      among remaining examples to node  $N$ 
16:    else
17:      Attach the subtree TRAINDECISIONTREE( $X_v$ ,
       $X^i - i$ ) to node  $N$ 
18:    end if
19:  end for
20:  return the root node  $N$  of the decision tree
21: end procedure

```

Algorithm 6 Decision Tree Evaluation

```

x: input data to be evaluated
procedure PREDICTION(node, x)
  if node is leaf node then
    return node.class-label
  end if
  if  $x.value <$  node.threshold then
    return PREDICTION(node.left, x)
  else
    return PREDICTION(node.right, x)
  end if
end procedure

```

4 Privacy-Preserving Decision Tree Training

In order to implement the privacy-preserving paradigm that achieves *no decryption* and zero-communication with the client during the training procedure, it is helpful to divide the training process into high-level steps. These steps can then be

tackled with techniques mentioned above in Algorithms 1 - 3. A flowchart outlining these steps is shown in figure 3. The first step is the feature selection phase, where the feature to be used as the root node is selected from the original dataset. Second, with the ideal feature selected as the root node, the data splitting phase is executed in order to proceed to the left and right child nodes of the root node. Next, the tree growing phase is initiated where the decision tree continues to recursively build and train using aspects of the feature selection phase and data splitting phase. Lastly, the training procedure is stopped and results returned to the client during termination phase when a chosen termination criteria are met. For simplicity, this paper assumes the dataset consists of binary categorical data and labels. However, this paradigm is applicable for any other data type (floating point numbers, integers, etc.) so long as they can be represented in binary format.

The approach of *no decryption* machine learning training protocol with FHE is a novel attempt aimed at demonstrating that this approach is a valid and implementable method of performing decision tree training and inference with privacy-preservation.

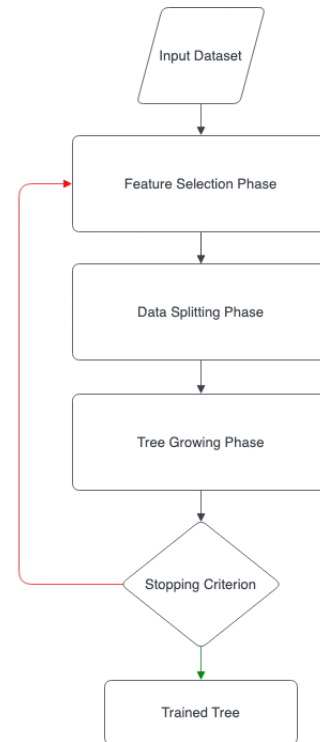

Figure 3: Training Flowchart

4.1 Feature Selection Phase

On a high level, the feature selection process works much the same as that of a regular decision tree training algorithm; the

end goal is to select a feature that minimizes expected classification errors. There are many algorithms that are used to help with feature selection. Gini index for one, calculates the expected frequency of incorrect classifications in each feature (called Gini impurity) in order to select the feature with the lowest impurity. Information gain, on the other hand, calculates the level of usefulness in each feature and selects the feature that offers the highest information gain. The paradigm proposed in this work is agnostic to feature selection algorithms.

Feature 1	Feature 2	Feature 3	Label
T	F	T	T
F	F	T	F
T	T	T	T
T	F	F	F

Feature 1	001	T	F	T	T
Feature 2	010	F	F	T	F
Feature 3	100	T	T	T	F

Figure 4: feature IDs and column vectors

To proceed with the feature selection phase, the dataset and supporting variables must be initialized properly in order to allow for the entire process to be handled without decryption and intermediary communication with the client. First, an FHE-encrypted unique binary identification number (in the form of One-Hot-Encoding, or OHE) is assigned to each feature in the dataset as shown in Figure 4 (here, feature can be thought of as column data represented by column name/index). For instance, the example demonstrated in the results section uses the Phishing Website Detector dataset where each row represents one website entry to be determined as a phishing website or not and each column is a feature that represents a particular property of that website entry such as the existence of valid IP address or DNS record. By using feature IDs to represent feature names in FHE form, the server is able to identify features for the feature selection phase. While column indices can be used to access features and their elements, they are not FHE accessible and cannot interact with other FHE data because indices of vectors and matrices are in plaintext. Next, using the label/target vector in conjunction with feature IDs and their corresponding column vectors, encrypted Gini index algorithm (or any other feature selection algorithm) is performed to compute the encrypted Gini impurity value for each feature. Then, for each feature, it's given ID, column vector, and Gini impurity score are stored in a tuple like structure. These tuples are then stored in a list. Iterative use of blind comparison from Algorithm 1 on the encrypted Gini impurity values in conjunction with tuple-wise blind swapping from Algorithm 3 across the list of tuples correctly identifies the tuple with the lowest Gini impurity. This is why FHE representations of feature IDs are necessary. Without feature IDs being swapped alongside their Gini impurity values with blind swapping, there would be no way to keep track of which Gini impurity values corresponded with which feature once blind min/maxing was done. Finally, selected feature is used

as the root node. Algorithm 7 gives a simple outline for this phase.

Algorithm 7 Feature Selection Phase

```

1: procedure FEATURESELECTION(dataset)
2:   for features in dataset do
3:      $gini_i \leftarrow giniImpurity(feature_i)$ 
4:      $tupleList \leftarrow (feature_i.ohe, feature_i.column, gini_i)$ 
5:   end for
6:    $BLINDSORTING(tupleList)$ 
7:   remove the feature corresponding to tupleList[0] from
   the dataset
8:   return tupleList[0]
9: end procedure

```

4.2 Data Partitioning Phase

With a feature selected for the root node, the next step is to split the rest of the dataset into left and right subsets for the left and right child nodes of the root, respectively. The split is based on the root node's selected feature or the threshold assigned to root node. However, due to the fact that comparative evaluations in FHE give encrypted (blind) results, a hard-partition of the dataset cannot be performed. Therefore, the training paradigm of this paper uses a soft-partition technique of the dataset to simulate the splitting of data into left and right branches. Namely, aspects of feature data from the root node calculation are collected into a vector denoted as FLAG and is passed down to the left and right branches along with the entire dataset. A similar approach to the soft-partition technique used in this work is also used in [1].

For each row of the FLAG vector, if it is encrypted false, then that row from the original dataset belongs to the left branch of the tree. If the column data at that row is encrypted true, then that row from the original dataset becomes a part of the right branch. If the dataset had continuous data instead, the split would happen based on the column data's position with respect to a chosen threshold for that node. In other words, to split the dataset into left and right subsets, a comparison operation needs to be performed on each row to determine which subset a given row belongs to. The solution we present, shown in Algorithm 8, is to simulate the splitting of the dataset by passing the original dataset to both left and right subsets identically along with the FLAG vector. Because the FLAG vector can be used to determine which branch a given row belongs to, collapsing technique from Equation 3 can be used to correctly evaluate feature selection calculations for both left and right branches of the root node. With this approach, all nodes on the same level of the tree will contain identical data encrypted with FHE but still compute their feature selection processes correctly using the FLAG vector. Not only does this approach provide a way to perform data splitting operations on the server without decryption, but it also ensures that the

nodes give away absolutely no information about size and imbalances of subsets as well as the structure of the tree since an empty node will still contain the same data as other nodes on the same level.

Algorithm 8 Data Partitioning Phase

```

procedure DATAPARTITIONING(dataset, node)
  selectedFeature  $\leftarrow$  FEATURESELECTION(dataset)
  node.threshold  $\leftarrow$  selected threshold for this feature
  flag  $\leftarrow$  selectedFeature.column
  node.left  $\leftarrow$  (dataset, flag)
  node.right  $\leftarrow$  (dataset, flag)
end procedure

```

4.3 Tree Growing Phase

With a feature selected for the root node and data splitting phase having been executed, the next step is to continue growing the tree by populating child nodes and branching out until some termination criterion is met. Gini calculations on the child nodes are calculated much the same as the root node. However, because the tree has to simulate working with the left and right subsets of the data for left and right branches, FLAG vectors are used to collapse Gini calculations on the rows that correspond to a different branch. Data splitting phase and feature selection phase that are slightly modified to support subset calculations are recursively performed for each child node at each level of the decision tree.

Algorithm 9 Tree Growing Phase

```

procedure TREEGROWING(dataset, flag, node)
  if termination criteria is met then
    return root
  end if
  perform feature selection and data partitioning phases
  TREEGROWING(dataset, flag, node.left)
  TREEGROWING(dataset, flag, node.right)
end procedure

```

4.4 Termination Phase

Decision trees are prone to overfitting and can overfit perfectly to training data unless some stopping criterion is employed to halt the training process. In the case of privacy-preserving decision tree paradigm proposed in this work, throughout the recursive process of tree growing phases, valid data entries (as determined by the FLAG vector) for each node in successive levels will grow smaller until every node in a given level no longer has any valid data left. Because of the nature of this paradigm, the training process will be blind to the fact that there is no valid data remaining to be trained and that the tree

expansion should be stopped. Therefore, stopping mechanism in the proposed FHE decision tree is necessary not only to minimize overfitting, but also to stop the tree from training indefinitely. There are many stopping criteria that can be employed to stop the training of decision trees. One of the most effective and straightforward methods is to simply set a maximum depth for a tree so that the tree stops training at a given depth even if further training can be done on remaining data. This method minimizes overfitting and can be implemented in a straightforward manner in the proposed FHE decision tree. An integer parameter denoting the maximum depth for the tree can be set by the client and passed to the server in plaintext to control the number of tree growing iterations performed during training. While providing this information in plaintext may appear to leak information about the tree, this information would already be known to the server if it was to perform inference with the decision tree, and therefore the solution proposed in this paper does not leak any information beyond what would already be known by the server.

4.5 Integrating the Phases

Having defined the different phases of the privacy-preserving decision tree training paradigm, they can be integrated into one unifying algorithm to demonstrate the proposed paradigm in full, as shown in Algorithm 10.

Algorithm 10 Privacy-Preserving Paradigm for Decision Tree Training

```

root: starting node, entry point for decision tree
procedure TRAININGALGORITHM(dataset)
  for features in dataset do
    ginii  $\leftarrow$  giniImpurity(featurei)
    tupleList  $\leftarrow$  (featurei.ohe, featurei.column, ginii)
  end for
  BLINDSORTING(tupleList)
  selectedFeature  $\leftarrow$  tupleList[0]
  remove the feature corresponding to tupleList[0] from the dataset
  root.threshold  $\leftarrow$  selected threshold for this feature
  flag  $\leftarrow$  selectedFeature.column
  if termination criteria is met then
    return root
  end if
  TREEGROWING(dataset, flag, root.left)
  TREEGROWING(dataset, flag, root.right)
end procedure

```

5 FHE Inference on Trained Tree

With the trained tree on the server, inference can be performed to evaluate new, incoming data. Although inference is not the

focal point of this paper and indeed many papers in the past have demonstrated decision tree inference with FHE, discussing inference in this paper is necessary to showcase how the decision tree trained using novel methodologies can be seamlessly transitioned for prediction. The prediction protocol takes a similar approach taken by [1] and converts the trained tree into a polynomial equation.

For prediction over binary, categorical data, threshold is also binary as it is in the case of Algorithm 11. In other words, For given $X^i \in X$, taking the right branch is correct if X^i is $\mathcal{E}(True)$ and taking the left branch is correct if X^i is $\mathcal{E}(False)$. Therefore, line 5 in Algorithm 11 ensures that the correct path of the tree continues with the prediction while the wrong path is collapsed in a manner similar to our collapsing algorithm shown in Algorithm 3.

Algorithm 11 Prediction Protocol: Binary

- 1: **predict**(*node*, *X*): where *node* refers to an FHE decision tree node containing feature information and *X* denoting the incoming validation data
 - 2: **if** *node* contains leaf value **then**
 - 3: **return** *node.leaf_value*
 - 4: **else**
 - 5: **return** $X^{node} \cdot \text{predict}(\text{node.right}, X) +$
 - 6: $X^{node} \cdot \text{predict}(\text{node.left}, X)$
 - 7: **end if**
 - 8:
-

Algorithm 12 Prediction Protocol: General

- 1: In the case where node and input are not binary, categorical data, requires threshold comparison to determine the correct evaluation path
 - 2:
 - 3: **if** *node* contains leaf value **then**
 - 4: **return** *node.leaf_value*
 - 5: **else**
 - 6: **return** $\text{BLINDCOMPARISON}(X^{node}, \text{node.threshold}) \cdot$
 - 7: $\text{predict}(\text{node.right}, X)$
 - 7: + $\text{BLINDCOMPARISON}(X^{node}, \text{node.threshold}) \cdot$
 - 7: $\text{predict}(\text{node.left}, X)$
 - 8: **end if**
-

For prediction in cases where it is necessary to have continuous or non-binary threshold values, one would need to employ Blind comparison from Algorithm 1 to compare the appropriate feature value from input data with the threshold value at any given node of the tree. This process is shown in Algorithm 12 where the results of blind comparisons are used for collapsing the prediction of wrong paths in the tree. This methodology of converting the trained decision tree into a polynomial equation representation and using the collapsing technique from Algorithm 3 ensures that correct result is obtained in prediction while maintaining privacy of data

Table 1: Validation accuracy of plaintext and encrypted models at 95% Confidence Interval

Tree Depth (d)	Plaintext Accuracy	Encrypted Accuracy
d = 1	47.9% ± 5.1%	42.9% ± 4.8%
d = 3	63.3% ± 5.2%	63.3% ± 5.6%

and even ensuring that the correct path is hidden to the server during runtime. This prediction protocol is independent of training protocol and can be used for any decision tree, plaintext or encrypted.

6 Results

Preliminary results were collected using the Phishing Website Detector dataset to showcase the validity of the training and prediction paradigm introduced in this paper. Rust library for TFHE from [22] is used for the code implementation of the training and prediction paradigm presented in this paper [15]. As of March 2023, [22] began supporting encrypted comparison and min/max operations using similar underlying techniques as Algorithm 1 and Algorithm 3 and these functions from [22] are used for implementation of this work. In addition, a completely plaintext version of the proposed paradigm is implemented in Python to benchmark the performance of the paradigm before introducing FHE. In order to alleviate computational complexity and costs, a primitive feature selection algorithm that measures class loss was implemented in place of Gini impurity at the cost of performance. Future work in this direction will focus on optimization of performance metrics of this privacy-preserving paradigm as well as efficiency in server-side computing as this paradigm is highly parallelizable. The preliminary results are shown in Table 1.

Validation accuracy for both plaintext and encrypted models were averaged after performing prediction on 30 batches of data as shown in Figure 5 and Figure 6, respectively. In addition, t-stat of 2.97×10^{-15} indicate that the plaintext and encrypted models are statistically consistent. This shows that this paradigm is a valid approach to decision tree training and prediction.

7 Conclusion

This work proposed a novel paradigm for performing privacy-preserving training and prediction with FHE. The proposed paradigm follows a *no-decryption* approach with no intermediary decryption or communication during both training and prediction. In addition, the paradigm keeps the architecture of the system streamlined by keeping with a client-server model without additional parties involved. The preliminary results gathered in this work confirms that this paradigm presents a

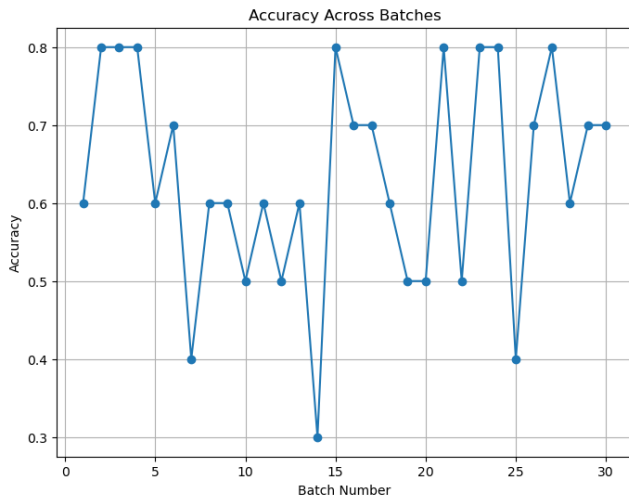

Figure 5: Plaintext Results

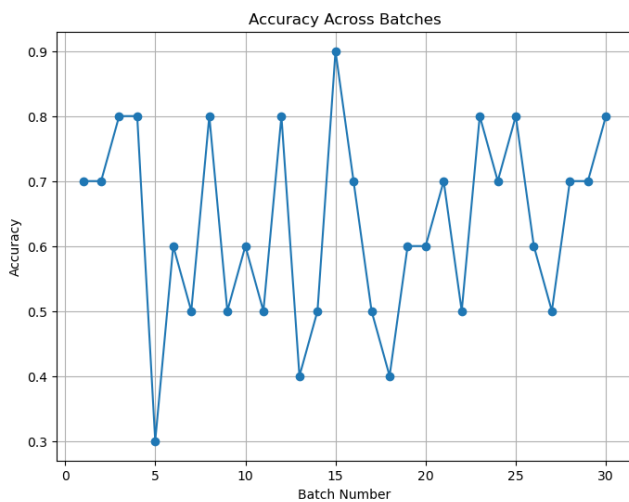

Figure 6: Encrypted Results

feasible approach to privacy-preserving decision trees as well as privacy-preserving machine learning as a whole.

The aim for future work is two-pronged. First, this research effort aims to address computational complexities and costs of this paradigm with parallelization techniques and more powerful computing units to make this paradigm trainable at a larger scale. Second objective is to introduce optimization efforts for performance metrics such as replacing primitive feature selection techniques with state-of-the-art algorithms and introducing cross-validation techniques into the paradigm.

Acknowledgment

This work was funded by BALANCED Media|Technology (BMT), a company that may potentially benefit from the research results. Corey Clark has an equity interest in BMT and also serves as the company’s chief technology officer. The terms of this arrangement have been reviewed and approved by the Southern Methodist University in accordance with its conflict of interest policies.

References

- [1] AKAVIA, A., LEIBOVICH, M., RESHEFF, Y. S., RON, R., SHAHAR, M., AND VALD, M. Privacy-preserving decision trees training and prediction. *ACM Transactions on Privacy and Security* 25, 3 (2022), 1–30.
- [2] ANJULI, S. A., AND SATJAJIT, A. 2-bit magnitude comparator design using different logic styles. *International Journal of Engineering Science Invention* 2, 1 (2013), 13–24.
- [3] AYTEKIN, C. Neural networks are decision trees. *arXiv preprint arXiv:2210.05189* (2022).
- [4] BOURA, C., GAMA, N., GEORGIEVA, M., AND JETCHEV, D. Chimera: Combining ring-lwe-based fully homomorphic encryption schemes. *Journal of Mathematical Cryptology* 14, 1 (2020), 316–338.
- [5] CHEON, J. H., KIM, A., KIM, M., AND SONG, Y. Homomorphic encryption for arithmetic of approximate numbers. In *Advances in Cryptology—ASIACRYPT 2017: 23rd International Conference on the Theory and Applications of Cryptology and Information Security, Hong Kong, China, December 3-7, 2017, Proceedings, Part I 23* (2017), Springer, pp. 409–437.
- [6] CHILLOTTI, I., GAMA, N., GEORGIEVA, M., AND IZABACHÈNE, M. Tffe: fast fully homomorphic encryption over the torus. *Journal of Cryptology* 33, 1 (2020), 34–91.
- [7] CHILLOTTI, I., JOYE, M., AND PAILLIER, P. Programmable bootstrapping enables efficient homomorphic inference of deep neural networks. Cryptology ePrint Archive, Paper 2021/091, 2021.
- [8] DE HOOGH, S., SCHOENMAKERS, B., CHEN, P., AND OP DEN AKKER, H. Practical secure decision tree learning in a tele-treatment application. In *Financial Cryptography and Data Security: 18th International Conference, FC 2014, Christ Church, Barbados, March 3-7, 2014, Revised Selected Papers 18* (2014), Springer, pp. 179–194.
- [9] DU, W., AND ZHAN, Z. Building decision tree classifier on private data.
- [10] GENTRY, C. Fully homomorphic encryption using ideal lattices. In *Proceedings of the forty-first annual ACM symposium on Theory of computing* (2009), pp. 169–178.

- [11] GILAD-BACHRACH, R., DOWLIN, N., LAINE, K., LAUTER, K., NAEHRIG, M., AND WERNING, J. Cryptonets: Applying neural networks to encrypted data with high throughput and accuracy. In *International conference on machine learning* (2016), PMLR, pp. 201–210.
- [12] HESAMIFARD, E., TAKABI, H., GHASEMI, M., AND WRIGHT, R. N. Privacy-preserving machine learning as a service. *Proc. Priv. Enhancing Technol.* 2018, 3 (2018), 123–142.
- [13] KIM, A., SONG, Y., KIM, M., LEE, K., AND CHEON, J. H. Logistic regression model training based on the approximate homomorphic encryption. *BMC medical genomics* 11, 4 (2018), 23–31.
- [14] KIM, M., SONG, Y., WANG, S., XIA, Y., JIANG, X., ET AL. Secure logistic regression based on homomorphic encryption: Design and evaluation. *JMIR medical informatics* 6, 2 (2018), e8805.
- [15] LEE, H. Privacy preserving decision tree training and prediction with no decryption - implementation, 2023. <https://github.com/timlee0131/Privacy-Preserving-Decision-Tree-Training-and-Prediction-with-No-Decryption—Implementation>.
- [16] LI, R., ISHIMAKI, Y., AND YAMANA, H. Fully homomorphic encryption with table lookup for privacy-preserving smart grid. In *2019 IEEE International Conference on Smart Computing (SMARTCOMP)* (2019), pp. 19–24.
- [17] LINDELL, Y., AND PINKAS, B. Privacy preserving data mining. In *Advances in Cryptology — CRYPTO 2000* (Berlin, Heidelberg, 2000), vol. 1880 of *Lecture Notes in Computer Science*, Springer.
- [18] LIU, L., CHEN, R., LIU, X., SU, J., AND QIAO, L. Towards practical privacy-preserving decision tree training and evaluation in the cloud. *IEEE Transactions on Information Forensics and Security* 15 (2020), 2914–2929.
- [19] LU, W.-J., HUANG, Z., HONG, C., MA, Y., AND QU, H. Pegasus: bridging polynomial and non-polynomial evaluations in homomorphic encryption. In *2021 IEEE Symposium on Security and Privacy (SP)* (2021), IEEE, pp. 1057–1073.
- [20] SINGH, P., AND JAIN, P. K. Design and analysis of low power, high speed 4-bit magnitude comparator. In *2018 International Conference on Recent Innovations in Electrical, Electronics & Communication Engineering (ICRIECE)* (2018), IEEE, pp. 1680–1683.
- [21] YOUNIS, M. I., AND ZAMLI, K. Z. A strategy for automatic quality signing and verification processes for hardware and software testing. *Advances in Software Engineering 2010* (2010).
- [22] ZAMA. TFHE-rs: A Pure Rust Implementation of the TFHE Scheme for Boolean and Integer Arithmetics Over Encrypted Data, 2022. <https://github.com/zama-ai/tfhe-rs>.

Notes