

EXPRESSIVE PARAGRAPH TEXT-TO-SPEECH SYNTHESIS WITH MULTI-STEP VARIATIONAL AUTOENCODER

Xuyuan Li^{♣†*}, Zengqiang Shang^{♣†*}, Jian Liu[♣], Hua Hua^{♣†}, Peiyang Shi^{♣†}, Pengyuan Zhang^{◇♣†}

♣ Laboratory of Speech and Intelligent Information Processing, Institute of Acoustics, CAS, China

† University of Chinese Academy of Sciences, China

ABSTRACT

Neural networks have been able to generate high-quality single-sentence speech with high expressiveness. However, it remains a challenge concerning paragraph-level speech synthesis due to the need for coherent acoustic features while delivering sentence styles. Meanwhile, training those models directly on over-length speech suffers from degrading synthesizing quality. This paper proposes a high-quality and expressive paragraph speech synthesis system with a multi-step variational autoencoder. Our approach employs multi-step latent variables to capture speech information and predicts them with text information separately at different grammatical levels. We also propose a three-step training method to promote the performance of the decoupling process. The proposed TTS model was trained on a single-speaker French audiobook corpus released at Blizzard Challenge 2023. Experimental results underscore the significant superiority of our system over baseline models.

Index Terms— Paragraph speech synthesis, Expressive speech synthesis, Text-to-speech, Multi-step VAE

1. INTRODUCTION

Thanks to the development of neural networks, the current Text-to-speech (TTS) models [1, 2, 3, 4] have found extensive application across domains such as human-computer interaction, voice broadcasting, and intelligent navigation where only the single-sentence speech synthesis is required. However, in contexts such as audiobooks, synthesizing long-time speech for paragraph text is necessary. Concurrently, expressing the change of emotion and style between sentences is also important to bring a good listening experience and draw attention to the emphasized information. Unfortunately, the sound quality and expression of speech synthesized by models trained on paragraph speech are still not as good as those trained on single-sentence speech.

The most common method of obtaining paragraph speech is directly splicing synthesized single sentences of speech together. To make the acoustic features consistent between the

spliced sentences, some early work [5, 6] spliced speech clips together with the post-adjustment of pitch, duration, and energy. MaskedSpeech [7] predicted the current sentence mel-spectrograms by before and after mel-spectrograms, but the invisible future information in the inference leads to a mismatch between training and inference. Another work[8] predicted the phonological style of the whole paragraph with context information, which can synthesize paragraph speech with coherent features at once. However, this method directly used the single sentence TTS model to capture information about the entire paragraph speech resulting in a degradation of speech quality. And it also neglects to model the change of emotion and style.

Previous expressive text-to-speech synthesis studies have paid little attention to paragraph speech synthesis. Therefore, we only present the development of single-sentence expressive speech synthesis. To enhance the expressiveness of speech in specific contexts, [9, 10] et al. used contextual linguistic information as the direct conditional input of their models. Furthermore, [11, 12, 13] demonstrated that introducing linguistic information in the form of grammatical structures is more helpful in modeling the emotion and style of single sentences than introducing linguistic information directly. However, these efforts either need to extract additional priori features or are limited by the posterior collapse problem of hierarchical variational autoencoder (HVAE), neither of which can be directly applied to paragraph text-to-speech synthesis.

In this paper, we propose an expressive paragraph speech synthesis system with a multi-step variational autoencoder (EP-MSTTS) to decouple and predict paragraph speech features in multiple grammatical dimensions. Our proposed network consists of three modules, i.e., a multi-step audio posterior encoder (MSAE), a multi-step text prior encoder (MSTE), and a multi-step decoder (MSD). In addition, a multi-step training strategy is designed to solve the posterior collapse problem automatically. Lastly, we conducted experiments to compare the proposed system with other mainstream paragraph TTS systems, both subjectively and objectively.

Our main contributions are summarized as follows:

- We develop EP-MSTTS, to our knowledge, the first framework generalizes high-quality and expressive speech

These authors * have contributed equally to this work.

◇ Correspondence: zhangpengyuan@hcl.ioa.ac.cn

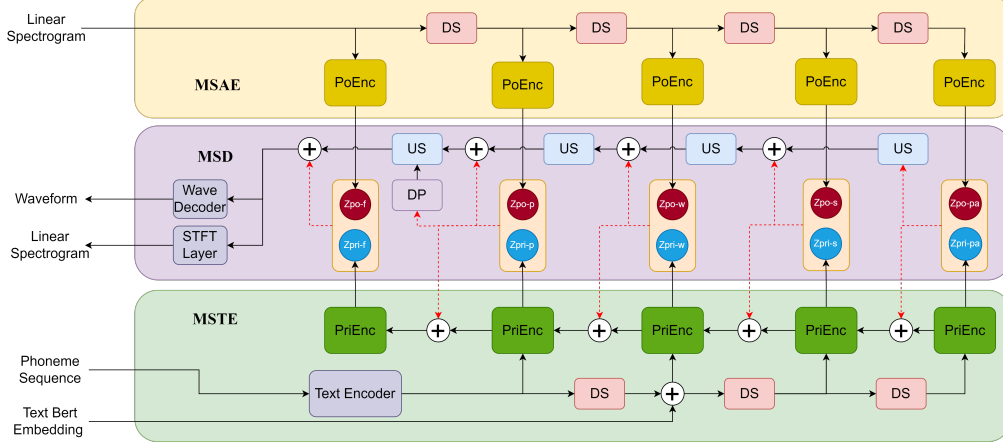

Fig. 1. The model architecture of EP-MSTTS. The DS, US, and DP denote "downsampling", "upsampling" and "duration prediction" operations; the PoEnc and PriEnc denote "Posterior Encoder" and "Prior Encoder" modules.

synthesis to paragraph text.

- We propose a multi-step training schedule that helps our model to better capture the speech information at paragraph and sentence levels.

2. METHOD

The overall architecture of our model is shown in Fig.1. It has a top-down five-layer structure including L_f , L_p , L_w , L_s , L_{pa} , which represent the frame layer, phoneme layer, word layer, sentence layer, and paragraph layer. It is worth mentioning that our structure is not an HVAE, which reconstructs the waveform using only the last layer of latent variables such as HierTTS [13]. Instead, each layer of latent variables in our model makes a direct contribution to waveform reconstruction, which means our model can decouple and precisely control the style of different words and sentences within a single paragraph.

2.1. Mutil-step Audio Encoder

In paragraph speech, there are large differences in emotion and style between different types of sentences and even the words in the same utterance can have large disparities. Thus, modeling the emotion and style information at different grammatical levels is appropriate. As shown at the top of Fig.1, the MSAE downsamples the fine-grained information step by step to obtain different levels of coarse-grained information. The information of each step is encoded into latent variables by the posterior prediction module G_{post} :

$$u_i, \sigma_i = G_{post}(H_{audio-i}) \quad (1)$$

where u_i and σ_i represent means and variances of the posterior latent variables, and $H_{audio-i}$ represents the audio information obtained by downsampling at step i . As the

HierTTS[13] mentioned, the information in the initial step is much larger than in the subsequent steps. For the frame level posterior encoder, we follow the posterior coding module mentioned in VITS [3], and for the other levels, we use a convolution layer plus a softplus activation function as the posterior predictor. Unlike the hierarchical audioencoder in [13], to avoid posterior latent variables learning useless information directly from the text, our MSAE only learns information from the audio, instead of adding textual information directly to aid the prediction of the posterior latent variables.

2.2. Mutil-step Text Encoder

Rough-to-fine iterative generation can produce better results than single-step generation[14]. In other words, the information from the higher level should guide the lower level information to fluctuate within a specific range. For example, sentence-level information can determine the average pitch of each word within this sentence, while word-level information controls the amount of pitch variation for each word. Based on this principle, we followed the multi-layer decoder from [13] and added a new paragraph text module on top as the architecture of our MSTE. As shown at the bottom of Fig. 1, the MSTE encodes textual prior information at different levels, starting from the paragraph level. The specific operation of each step is written as follows:

$$S_i, u_i, \sigma_i = G_{pri}(US(S_{i-1} + Z_{i+1}), H_{txt-i}) \quad (2)$$

The prior predictor G_{pri} predicts the means u_i and variances σ_i of prior latent variables with posterior latent variables Z_i , text information H_{txt-i} , and the hidden state of prior predictor S_{i-1} from the previous step. Specially, for the L_f , H_{txt-i} is None, and for the L_{pa} , $(S_{i+1} + Z_{i+1})$ is None. All prior predictors consist of feed-forward transformer (FFT) blocks [1].

2.3. Mutil-step Decoder

The middle part of Fig.1, shows the specific construction of the MSD. To make the Z at each step learn useful information and eliminate the cumulative error of multiple random samples in HVAE, we upsample the hidden variables h of the upper step and stitch it with Z at each step. The hidden variable for decoding at each layer is given by equation (3).

$$h_i = US(h_{i-1}) + Z_i \quad (3)$$

As for the structure of the final decoder step, we use the generator of [15] to reconstruct the speech waveform. Since the latent variables at each step all contribute to the reconstruction of the original waveform, the posterior collapse problem, which is more likely to occur as the number of layers of HVAE increases, is alleviated to some extent.

3. TRAINING SCHEDULE

We use the Multi-Period Discriminator [2] and the Multi-Resolution Discriminator [15] for adversarial training. The total loss of our generator is given by equation (4).

$$\mathcal{L}_{tot} = \lambda_g \mathcal{L}_g + \lambda_{s1} \mathcal{L}_{s1} + \lambda_{s2} \mathcal{L}_{s2} + \lambda_{kl} \mathcal{L}_{kl} + \lambda_d \mathcal{L}_d \quad (4)$$

$$\mathcal{L}_{kl} = \alpha_f \mathcal{L}_f + \alpha_p \mathcal{L}_p + \alpha_w \mathcal{L}_w + \alpha_s \mathcal{L}_s + \alpha_{pa} \mathcal{L}_{pa} \quad (5)$$

λ and α are the weighting coefficients of each loss. \mathcal{L}_g represents the adversarial training loss. \mathcal{L}_{s1} quantifies the fidelity of linear spectrogram feature reconstruction, while \mathcal{L}_{s2} pertains to the restoration of the waveform. \mathcal{L}_d calculates the Mean Square Error of two phoneme durations. The final term \mathcal{L}_{kl} represents the weighted sum of KL distances of prior and posterior variables for all steps.

In our experiments, we observed that directly training the total model would cause the decoder to tend to reconstruct the speech only from latent variables at the frame and word level due to the overpowering reconstruction capability of the decoder at the last step. This phenomenon underscores the necessity for a less potent decoder to force the encoder to supply more useful information. However, restructuring the waveform is difficult, and we cannot risk compromising the quality of the speech reconstruction by choosing a simple decoder structure. Inspired by MSMC-TTS [16], we design another task, predicting the linear spectrograms with a simple linear layer, at the final decode step. We also use the weight annealing [17] to ensure that our model has enough time to extract information from audio without text constraints. Specifically, our training strategy is divided into the following three steps:

1. First, the weight of \mathcal{L}_{kl} is set to a very small value. Only the MSAE and MSD are trained with the goal of reconstructing the linear spectrogram features.
2. λ_{kl} starts to increase slowly, and the training task of step 1 is continued.
3. The whole network gives up reconstructing the linear spectrogram features and instead reconstructs the speech waveform. Meanwhile, λ_{kl} increases to 1.

4. EXPERIMENTS

4.1. Dataset

In this work, we used a French audiobook dataset [18]. The dataset consists of 289 chapters of 5 audiobooks from Librivox read by a female native French speaker. The audio is encoded in the PCM format at a sampling rate of 22.05 kHz with transcribed text and aligned phoneme sequences.

4.2. Experiment settings

In our experiments, 150 sentences were selected for testing, and 150 sentences for validation, the remaining sentences were used for training. We used 512-dimensional linear spectrograms extracted with hop length of 13.6 ms and window length of 36.3 ms as the acoustic features.

The pre-trained ‘‘French Europeana BERT’’ model [19] released by Huggingface¹ was used to extract paragraph text embedding. Three models were implemented as comparison models, namely, VITS, VITS-BERT, and HierTTS. The BERT embedding which contains linguistic information of paragraph text, was added with phone embedding as a condition to assist the generation of latent variable in VITS-BERT. An additional paragraph layer, with the same structure as the original sentence layer, was added to the original HierTTS to model paragraph-level information. All generators of comparison models are identical to the final-step decoder of EP-MSTTS. As for other structures and parameters, we follow the setup described in the papers of VITS and HierTTS.

We used the same BERT model with a hidden size of 768 as VITS-BERT and HierTTS in our proposed model. The first and second steps of the training schedule were set to 10,000 and 30,000 respectively, and the λ_{kl} needed 100,000 steps to grow linearly to 1. The weights of each layer of KL loss α_f , α_p , α_w , α_s , and α_{pa} were set to 1, 0.25, 0.07, 0.01, and 0.005 respectively. A dynamic min batch size was used for all training, and the total length of each min batch of audio data was less than 218 seconds. All models were adequately trained on two NVIDIA V100 GPUs to fully converge.

4.3. Evaluation

4.3.1. Subjective Evaluation

We used the Mean Opinion Score (MOS) to evaluate the synthesized speech. 16 paragraphs² were randomly selected and synthesized by different models. Each audio was rated by 5

¹<https://github.com/huggingface/transformers>

²Our audio samples can be found at <https://lixuyuan102.github.io/EP-MSTTS/>.

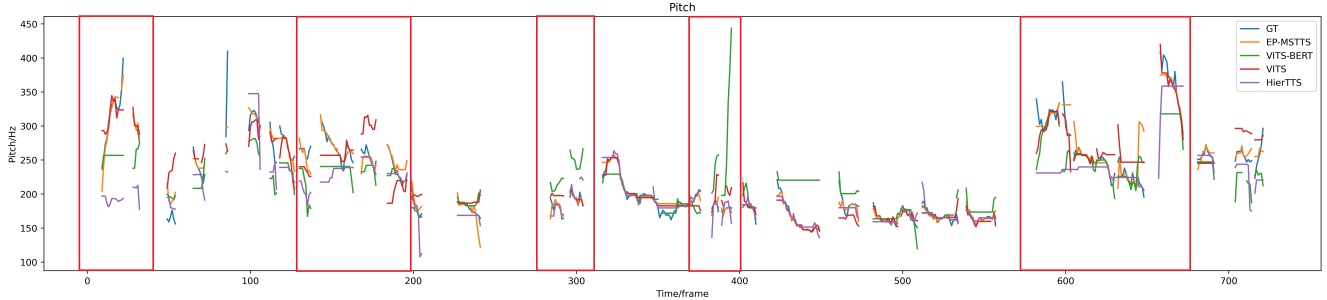

Fig. 2. Dynamic time-aligned pitch contours of passages in ground true audio and synthetic results for VITS, VITS-BERT, HierTTS, EP-MSTTS.

native French listeners in terms of speech quality, naturalness, coherence, and expressiveness on a scale from 1 to 5 with intervals of 0.5. The second column of Tab.1 shows the MOS with 95% confidence intervals. The speech synthesized by our method has the highest score, and the speech of HierTTS is the second highest. While the score of the speech synthesized by VITS-BERT and VITS was significantly lower than the former. This proves that our proposed model enhances the ability to capture the details of paragraph speech compared to single-sentence TTS models which solely rely on a phoneme layer. In terms of expressiveness, the speech style changes of EP-MSTTS are more obvious than VITS-BERT and HierTTS, which verifies that EP-MSTTS is better able to capture the changes in emotion and style at different grammatical levels.

Table 1. Subjective and objective comparison on test set

Metric	MOS ($\pm 95\%$ CI) \uparrow	MCD \downarrow	F0 RMSE \downarrow	E RMSE \downarrow
GT	4.32 \pm 0.113	-	-	-
VITS	2.98 \pm 0.141	5.3235	24.0328	0.7705
VITS-BERT	3.24 \pm 0.112	5.2504	23.8887	0.7567
HierTTS	3.78 \pm 0.126	5.3359	24.7375	0.7514
EP-MSTTS	4.02\pm0.121	5.1584	22.1857	0.7198

4.3.2. Objective Evaluation

We extracted the pitch of real and synthesized speech for a paragraph. All the pitch frequencies were stretched to the time scale of the real speech by the dynamic time alignment algorithm. As shown in the red boxes in Fig.2, the pitch curve of the speech synthesized by VITS, VITS-BERT, and HierTTS notably diverges from the curve of authentic speech. While our proposed method aligns more closely with real speech.

We further computed the mel-cepstrum distortion (MCD) and the Root Mean Square Error (RMSE) of F0 and energy.

The results are shown on the right side of Tab.1, where EP-MSTTS performs the best. Notably, HierTTS demonstrated an inferior performance compared to VITS in both MCD and F0-RMSE metrics, which can be attributed to the accumulation of errors due to the multiple random samples.

Table 2. Ablation test: Preferences of HierTTS and EP-MSTTS with or without our proposed training schedule.

Models	Left	On par	Right
EP-w/o & Hier-w/o	38.5	40.1	21.4
EP-w & EP-w/o	68.7	17.3	14.0

4.3.3. Ablation Experiment

Ultimately, we conducted preference tests to demonstrate the effectiveness of the proposed method. As shown in Tab.2, without using our proposed training strategy, our network focusing on paragraph speech obtains a preference of 38.5% compared to HierTTS. Furthermore, the preference significantly increased to 68.7% after using the proposed training schedule. This disparity hints our introduced training schedule effectively resolves the posterior collapse issue in deep multilayer VAE. Consequently, by effectively modeling audio information at different syntactic levels, we can obtain higher quality and expressive speech for passages.

5. CONCLUSION

In this paper, we propose a new multi-step variational autoencoder to model the acoustic features of paragraph speech. In addition, to decouple the acoustic features of paragraph speech into each layer, we propose a training schedule that progressively activates different network modules. Experiments demonstrate that the paragraph speech synthesized by our proposed network outperforms all the baseline models, and our proposed training scheme can help the network capture acoustic information at all grammatical levels.

6. REFERENCES

- [1] Yi Ren, Yangjun Ruan, Xu Tan, Tao Qin, Sheng Zhao, Zhou Zhao, and Tie-Yan Liu, “Fastspeech: Fast, robust and controllable text to speech,” *Advances in neural information processing systems*, vol. 32, 2019.
- [2] Jungil Kong, Jaehyeon Kim, and Jaekyoung Bae, “Hifigan: Generative adversarial networks for efficient and high fidelity speech synthesis,” *Advances in Neural Information Processing Systems*, vol. 33, pp. 17022–17033, 2020.
- [3] Jaehyeon Kim, Jungil Kong, and Juhee Son, “Conditional variational autoencoder with adversarial learning for end-to-end text-to-speech,” in *International Conference on Machine Learning*. PMLR, 2021, pp. 5530–5540.
- [4] Zengqiang Shang, Zihua Huang, Haozhe Zhang, Pengyuan Zhang, and Yonghong Yan, “Incorporating cross-speaker style transfer for multi-language text-to-speech,” in *Interspeech*, 2021, pp. 1619–1623.
- [5] Francesc Alias, Ignasi Iriondo, Lluís Formiga, Xavier Gonzalvo, Carlos Monzo, and Xavier Sevilla, “High quality spanish restricted-domain tts oriented to a weather forecast application,” in *Proc. of InterSpeech*, 2005, pp. 2573–2576.
- [6] Parakrant Sarkar and K Sreenivasa Rao, “Modeling pauses for synthesis of storytelling style speech using unsupervised word features,” *Procedia Computer Science*, vol. 58, pp. 42–49, 2015.
- [7] Ya-Jie Zhang, Wei Song, Yanghao Yue, Zhengchen Zhang, Youzheng Wu, and Xiaodong He, “Masked-speech: Context-aware speech synthesis with masking strategy,” *arXiv preprint arXiv:2211.06170*, 2022.
- [8] Liumeng Xue, Frank K Soong, Shaofei Zhang, and Lei Xie, “Paratts: Learning linguistic and prosodic cross-sentence information in paragraph-based tts,” *IEEE/ACM Transactions on Audio, Speech, and Language Processing*, vol. 30, pp. 2854–2864, 2022.
- [9] Jinlong Xue, Yayue Deng, Fengping Wang, Ya Li, Yingming Gao, Jianhua Tao, Jianqing Sun, and Jiaen Liang, “M 2-ctts: End-to-end multi-scale multi-modal conversational text-to-speech synthesis,” in *ICASSP 2023-2023 IEEE International Conference on Acoustics, Speech and Signal Processing (ICASSP)*. IEEE, 2023, pp. 1–5.
- [10] Yihan Wu, Xi Wang, Shaofei Zhang, Lei He, Ruihua Song, and Jian-Yun Nie, “Self-supervised context-aware style representation for expressive speech synthesis,” *arXiv preprint arXiv:2206.12559*, 2022.
- [11] Shubhi Tyagi, Marco Nicolis, Jonas Rohnke, Thomas Drugman, and Jaime Lorenzo-Trueba, “Dynamic prosody generation for speech synthesis using linguistics-driven acoustic embedding selection,” *arXiv preprint arXiv:1912.00955*, 2019.
- [12] Yi Lei, Shan Yang, Xincheng Wang, and Lei Xie, “Mse-motts: Multi-scale emotion transfer, prediction, and control for emotional speech synthesis,” *IEEE/ACM Transactions on Audio, Speech, and Language Processing*, vol. 30, pp. 853–864, 2022.
- [13] Zengqiang Shang, Peiyang Shi, Pengyuan Zhang, Li Wang, and Guangying Zhao, “Hiertts: Expressive end-to-end text-to-waveform using a multi-scale hierarchical variational auto-encoder,” *Applied Sciences*, vol. 13, no. 2, pp. 868, 2023.
- [14] Karol Gregor, Ivo Danihelka, Alex Graves, Danilo Rezende, and Daan Wierstra, “Draw: A recurrent neural network for image generation,” in *International conference on machine learning*. PMLR, 2015, pp. 1462–1471.
- [15] Won Jang, Dan Lim, Jaesam Yoon, Bongwan Kim, and Juntae Kim, “Univnet: A neural vocoder with multi-resolution spectrogram discriminators for high-fidelity waveform generation,” *arXiv preprint arXiv:2106.07889*, 2021.
- [16] Haohan Guo, Fenglong Xie, Xixin Wu, Frank K Soong, and Helen MengFellow, “Msmc-tts: Multi-stage multi-codebook vq-vae based neural tts,” *IEEE/ACM Transactions on Audio, Speech, and Language Processing*, 2023.
- [17] Samuel R. Bowman, Luke Vilnis, Oriol Vinyals, Andrew Dai, Rafal Jozefowicz, and Samy Bengio, “Generating sentences from a continuous space,” in *Proceedings of the 20th SIGNLL Conference on Computational Natural Language Learning*, Berlin, Germany, Aug. 2016, pp. 10–21, Association for Computational Linguistics.
- [18] Gérard Bailly, Olivier Perrotin, and Martin Lenglet, “Ressources for End-to-End French Text-to-Speech Blizzard challenge,” jan 2023.
- [19] Jacob Devlin, Ming-Wei Chang, Kenton Lee, and Kristina Toutanova, “Bert: Pre-training of deep bidirectional transformers for language understanding,” *arXiv preprint arXiv:1810.04805*, 2018.