

A Study on Robustness and Reliability of Large Language Model Code Generation

Li Zhong, Zilong Wang

University of California, San Diego

Abstract

Recently, the large language models (LLMs) have shown extraordinary ability in understanding natural language and generating programming code. It has been a common practice of software engineers to consult LLMs when encountering coding questions. Although efforts have been made to avoid syntax errors and align the code with the intended semantics, the reliability and robustness of the code generation from LLMs have not yet been thoroughly studied. The executable code is not equivalent to the reliable and robust code, especially in the context of real-world software development. The misuse of APIs in the generated code could lead to severe problem, such as resource leaks, program crashes, etc. To make things worse, the users of LLM code generation services are actually the developers that are most vulnerable to these code that seems right – They are always novice developers that are not familiar with the APIs that LLMs generate code for them. Therefore, they could hardly tell the misuse in the code generated by LLMs, which further facilitates the incorrect code applied in real-world software. Existing code evaluation benchmark and datasets focus on crafting small tasks such as programming questions in coding interviews, which however deviates from the problem that developers would ask LLM for real-world coding help. To fill the missing piece, in this work, we propose a dataset ROBUSTAPI for evaluating the reliability and robustness of code generated by LLMs. We collect 1208 coding questions from Stack Overflow on 24 representative Java APIs. We summarize the common misuse patterns of these APIs and evaluate them on current popular LLMs. The evaluation results show that even for GPT-4, 62% of the generated code contains API misuses, which would cause unexpected consequences if the code is introduced into real-world software.

Introduction

The new era of language modeling arrives when large language models (LLMs) show an extraordinary ability in understanding natural language and can even generate customized code according to the user’s needs (Ye et al. 2023; OpenAI 2023a; Anil et al. 2023). It is not surprising that more and more software engineers choose to query large language models for the answer to the coding questions, such as generating a code snippet of using APIs or detecting bugs

in a few lines of code. Large language models are able to retrieve more suitable and customized answer for the question compared with searching in the online programming forums, such as Stack Overflow¹.

Such fast pace conceals potential risks in the code generation of large language models. From the perspective of software engineering, the robustness and reliability of generated code have not yet been thoroughly studied even if numerous works have been made to avoid syntax errors and improve semantic understanding in the generated code (Chen et al. 2021; Shen et al. 2023a; Luo et al. 2023). Unlike the online programming forums, the generated code snippets are not reviewed by the community peers and thus suffer from API misuse, such as missing boundary checking in file reading and variable indexing, missing file I/O closing, failure in transaction completion, etc. Even if the code samples are executable or functionally correct, the misuse can trigger serious potential risks in products, such as memory leaks, program crashes, garbage collection failures, etc. To make things worse, the programmers asking these questions are the most vulnerable ones to the risk since they are more likely to be novice to the APIs and cannot tell the violations in the generated code snippets. Therefore, it is essential to contemplate the code reliability while evaluating the code generation by large language models.

To evaluate the code generation of large language models, most of the existing benchmarks focus on the functional correctness of the execution result from the generated code, which means the code is acceptable as long as it is functional for the user’s purpose (Chen et al. 2021; Yin et al. 2018; Lu et al. 2021). We argue that the correct execution result is important but it is not always the case in the software development scenario. What the engineers really need is a reliable code sample of the new APIs without potential risks in the long run. Moreover, the domain of most current programming questions are far from software engineering. The data source is mostly online coding challenge websites, such as Codeforces, Kattis, Leetcode, etc (Hendrycks et al. 2021; Austin et al. 2021). Although remarkable progresses have been made, we argue that they fail to substantially help the software development in practical scenarios.

To this end, we propose ROBUSTAPI, an comprehensive

¹<https://stackoverflow.com>

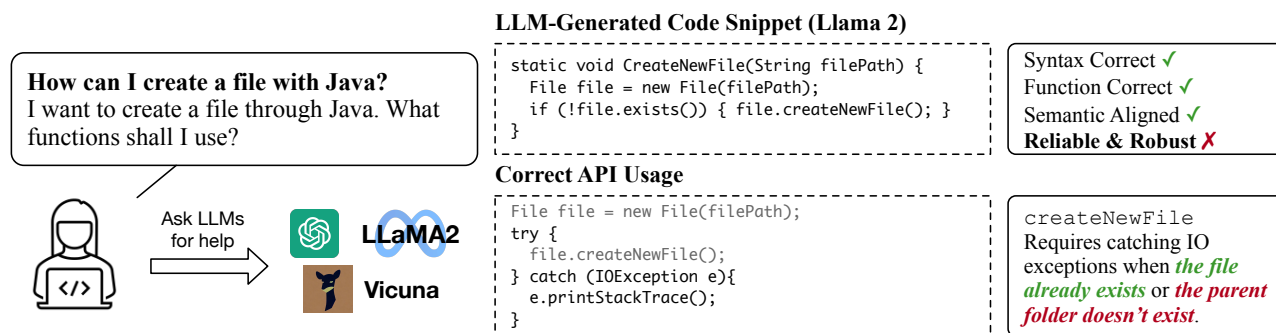

Figure 1: The scenario where software engineers consult large language models for the answer to the programming questions. The generated code snippet is not reliable and there exist potential risks in the software development.

benchmark to evaluate the reliability and robustness of code generated by large language models, including a dataset of coding questions and an evaluator using the abstract syntax tree (AST) (Fischer, Lusiardi, and Von Gudenberg 2007). In the dataset, we target at creating an evaluation setting which is close to the real software development. Thus we collect representative questions about Java from Stack Overflow. Java is one of the most popular programming languages and widely used in software development because of its *write once, run anywhere (WORA)* feature². For each question, we provide the detailed description and the related Java API. We design templates to trigger large language models to generate the code snippet and the corresponding explanation. We also provide an evaluator which analyzes the generated code snippets using the abstract syntax tree (AST) and compares them with the expected API usage patterns. Following Zhang et al. (2018), we formalize the API usage patterns into structured call sequences, as shown in FIGURE. The structured call sequences present how these APIs can be properly used to eliminate the potential system risks. Any violations of such structured call sequences would be considered as failure from the perspective of software engineering.

We collect 1208 real questions from Stack Overflow which involves 24 representative Java APIs. We run experiments on the close-sourced language models (GPT-3.5 and GPT-4 (OpenAI 2023a)) as well as the open-sourced language models (Llama-2 (Touvron et al. 2023), Vicuna-1.5 (Chiang et al. 2023)). We use the default hyper-parameter settings of the models without further extensive hyper-parameter tuning. We further design two experiment settings, zero-shot and one-shot, where none or one demonstration sample is provided in the prompt. We conduct comprehensive analysis of the generated code and study the common API misuse cases of current large language models. We would like to bring up the important issues of the API misuse in the code generation by large language models, and provide a new dimension to evaluate large language models other than the commonly-used functional correctness. The main purpose of this benchmark is not to evaluate the functional correctness of the generated code, but instead, we focus on the reliability and robustness. We hope this work

²[https://en.wikipedia.org/wiki/Java_\(programming_language\)](https://en.wikipedia.org/wiki/Java_(programming_language))

could facilitate future research on this topic and help create a more robust coding helper out of large language models to step further into the real artificial general intelligence. We will open-source our dataset and evaluator on GitHub. We summarize our contribution as follows.

- We propose a new benchmark, ROBUSTAPI, to evaluate the reliability and robustness of code generation by large language models. This is an important but not yet well studied perspective to evaluate the code quality apart from functional correctness.
- We provide a well formalized evaluation framework including a dataset of Stack Overflow questions and an API usage checker using AST. We report performance of popular large language models, including GPT-3.5, GPT-4, Llama-2, Vicuna-1.5.
- We conduct comprehensive analysis of the code generation performance of current large language models. We summarize the common API misuse for each model and point out the promising improvement direction for future research.

Related Work

Code Quality of LLM-Sythesized Code With the release of Copilot (Chen et al. 2021) and other commercial code assistant tools based on LLMs, the security and code quality of these tools gradually get the attention of research community. Yetistiren, Ozsoy, and Tuzun (2022) assesses the quality of LLM-generated code from the aspects of compilation correctness, functional correctness and code efficiency. Siddiq et al. (2022) studies code smells in code generated by LLMs, which is the poor design in code like unusually long method, or duplicated code. Poesia et al. (2022) shows that LLMs can make implementation errors in the code like syntax error or semantic errors deviating from users' intention. Jesse et al. (2023) studies simple, stupid bugs in Codex and other LLMs, which shows that AI code assistants can help avoid some of such simple bugs but have a higher change of introducing bugs that are hard to detect. As for security impact, Pearce et al. (2022) designs 89 security-sensitive scenarios for Copilot to complete the code for users, which shows approximately 40% of the code is

vulnerable. Perry et al. (2022) conducts the first large-scale user study to examine whether users interact with AI Code assistant write secure code. And they find that those users wrote significantly less secure code while they believe their code were secure. Sandoval et al. (2023) conducts user study to assess the security of low-level code with pointer and array manipulations generated by AI-based coding assistants. They find under this specific scenario, the assistants does not introduce more security bugs than human. Liu et al. (2023) enlarges HumanEval (Chen et al. 2021) by generating test cases with higher coverage which serve as an add-on to the existing programming benchmarks but the evaluation still focuses on the functional correctness and simple programming questions far from software development. Shen et al. (2023b) evaluates the reliability of ChatGPT³ by testing on adversarial examples, which however has a different meaning of ‘reliability’ in their context. In this paper, we refer reliability as the ability of code to be resisted to failure, high workload, and unexpected input.

Quality Assessment of Code in Online Forum Existing literature in software engineering field has investigated the quality of code from online forum and warn developers of the potential issues. Yang, Hussain, and Lopes (2016) finds that the majority of code examples given in Stack Overflow answers cannot be compiled. Zhou and Walker (2016) points out that 43% of the posts investigated by them contains deprecated APIs, while Fischer et al. (2017) find that 29% of the code contains security risks. In Zhang et al. (2018), the authors analyze the code by call sequence extraction and slicing, and compare to the manually validated API usage rules, which concludes that 31% of the code examples in Stack Overflow answers contains API misuse and could produce unexpected behaviors.

Methodology

In this section, we describe ROBUSTAPI, which is a comprehensive benchmark we build to thoroughly evaluate the reliability and robustness of LLM-generated code. We describe the process of data collection and prompt generation when constructing the dataset. Then we present the API misuse patterns evaluated in ROBUSTAPI and discuss the potential consequence of violations. Finally, we introduce the static analysis method in ROBUSTAPI for detecting the API usage violations which leverages the abstract syntax tree and achieves higher evaluation accuracy in evaluating the API misuse in code generated by LLMs compared to rule-based method such as keywords matching.

Data Collection

To take advantage of the existing research efforts in the software engineering field, we build ROBUSTAPI based on the dataset from ExampleCheck (Zhang et al. 2018) as our starting point. ExampleCheck is proposed to study the frequent Java API misuse in online Q&A forums. We select 23 popular Java APIs from the dataset as shown in Table 1. These 23 APIs cover 5 domains including string processing, data

structure, mobile development, crypto and database operation. Then we crawl questions relevant to these APIs from Stack Overflow. We only select the questions with online answers and we keep the questions whose provided answer contains API misuse. In this way, we guarantee that the questions in ROBUSTAPI are answerable and non-trivial so we can use them to effectively evaluate the LLMs’ ability in answering coding questions that *humans are prone to make mistakes*. After filtering, we get 1208 questions in total. The distribution of questions for each domain is shown in Table 1.

	API	Domain
1	StringTokenizer.nextToken	String
2	String.getBytes	Processing
3	JsonElement.getAsString	(307)
4	List.get	Data
5	Map.get	Structure
6	SortedMap.firstKey	(404)
7	Iterator.next	
8	ProgressDialog.dismiss	
9	Activity.findViewById	Mobile
10	TypedArray.getString	Development
11	ApplicationInfo.loadIcon	(75)
12	Activity setContentView	
13	Cipher.init	Crypto (10)
14	Mac.doFinal	
15	RandomAccessFile.read/write/close	
16	BufferedReader.readLine	
17	PrintWriter.read/write/close	
18	DataOutputStream.read/write/close	File I/O (390)
19	File.mkdirs	
20	InputStream.read	
21	File.createNewFile	
22	FileChannel.write	
23	SQLiteDatabase.query	Database (22)
	Total	(1208)

Table 1: 23 popular Java APIs in ROBUSTAPI. They are easily misused by developers according to the existing literature of software engineering (Zhang et al. 2018).

After collecting the questions, we convert them into the JSON format with the following fields: {id, api, question, origin}. id field contains the unique id we assign for each sample. api field contains the API that we specifically instruct the large language models to use as a question hint. question field contains the title and description of the Stack Overflow questions. origin field contains the original URL of this sample.

Prompt Generation

In ROBUSTAPI, we design a prompt template and fill it with samples from our dataset. We collect the response from LLMs and implement an API usage checker to evaluate the code reliability. In the prompt, we start with the task introduction and the required response format. Then we append the few-shot demonstrations when conducting experiments in the few-shot settings. The demonstration examples satisfy our provided response format. In our zero-shot setting,

³<https://chat.openai.com>

we skip this step. Next, we append the question and the corresponding API hint from one sample in our dataset. This prompt simulates a user asking coding questions without providing any additional hints from the API documentation which is a typical scenario when novice developers seek for help from language language models. Due to the chat completion nature of state-of-the-art LLMs, we wrap the question and answer with special tags to instruct LLMs to generate answers to the questions. Here is an example of the prompt:

Prompt:
 Please answer my code questions using the given API following this format:
 <<<api>>>: \$API
 <<<code>>>: \$CODE
 <<<explanation>>>: \$EXPLANATION
 [Few-shot samples if applicable...]
 Question: I have just started learning java for android. I set the TextVisibility of a textfield to GONE, I need the TextVisibilty to change to VISIBLE after 7 seconds from Button click.
 Please using this api Activity setContentView.
 Answer:

Demonstration Samples

Demonstration samples have been proven helpful to LLMs in understanding natural language. To thoroughly analysis LLMs' ability in code generation, we design two few-shot settings, One-shot-irrelevant and One-shot-relevant.

In the one-shot-irrelevant setting, we provide LLMs with an example using an irrelevant API (e.g. Arrays.stream). We assume this demonstration example would eliminate the syntax errors in the generated code. The irrelevant example we use in ROBUSTAPI is as follows:

One-shot-irrelevant Demo Example:
 Question: How can I calculate the sum of an array in Java?
 <<<api>>>: Arrays.stream
 <<<code>>>: int[] array = 1, 2, 3, 4, 5;
 int sum = Arrays.stream(array).sum();
 <<<explanation>>>: The sum() method of the IntStream class returns the sum of elements in this stream.

In the one-shot-relevant setting, we provide LLMs with an example using the same API as the given question. The provided example contains a pair of question and answer. The question in the demo example does not present in the testing dataset and we manually revise the answer to ensure that there is no API misuse in it and the semantics well align with the questions.

Java API Misuse

When using the APIs provided by language libraries, developers need to follow the API usage rules so that they can take full advantage of the ideal API effect. Violating these rules and misusing the APIs could result in unexpected behaviors in production. A typical example is the file operation. When opening and writing to a file through RandomAccessFile, two usage rules need to be enforced:

(1) Reading the file could throw exceptions. If the buffer limit is reached before expected bytes are read, the API would throw IndexOutOfBoundsException. Also, the file is concurrently closed by other processes, the API would throw ClosedChannelException. To deal with these exceptions, the correct implementation should enclose the API inside try-catch blocks. (2) The file channel should be closed after usage. Otherwise, if this code snippet is inside a long-lasting program that are concurrently running in multiple instances, the file resources could be run out. Therefore, the code need invoke close API after all file operations. The correct usage and possible misuse are shown as following:

Correct API Usage:

```
try {
  RandomAccessFile raf =
    new RandomAccessFile("/tmp/file.json", "r");
  byte[] buffer = new byte[1024 * 1024];
  int bytesRead = raf.read(buffer, 0, buffer.length);
  raf.close();
} catch(Exception e) {...}
```

Violation: Unhandled Exception

```
RandomAccessFile raf =
  new RandomAccessFile("/tmp/file.json", "r");
byte[] buffer = new byte[1024 * 1024];
int bytesRead = raf.read(buffer, 0, buffer.length);
raf.close();
```

Another example of API usage rules that are easily misused is TypedArray, a special data object that requires the developers to invoke recycle() to manually enable garbage collection. Otherwise, the garbage collection in Java virtual machine will not be triggered even after there are not further uses of this TypedArray. Using this API without garbage collection will result in unreleased memory consumption, which in production will degrade or even suspend the software system under large workload and high concurrency.

Correct API Usage:

```
TypedArray array = res.obtainTypedArray(R.array);
try {
  font_name = a.getString(R.styleable.font);
} finally {
  a.recycle();
}
```

Violation: Unreleased Resource

```
TypedArray array = res.obtainTypedArray(R.array);
font_name = a.getString(R.styleable.font);
```

In ROBUSTAPI, we summarized 40 API usage rules from the 23 APIs (see Appendix), which are validated in the documentations of these APIs (Zhang et al. 2018). These rules include: (1) The guard condition of a API, which should be checked before API calls. For example, check the result of File.exists() before File.createNewFile() (2) Required call sequence of a API, which should be called in specific order. For example, call close() after File.write(). (3) Control structures of a API. For example, enclose SimpleDateFormat.parse() with try-catch structure.

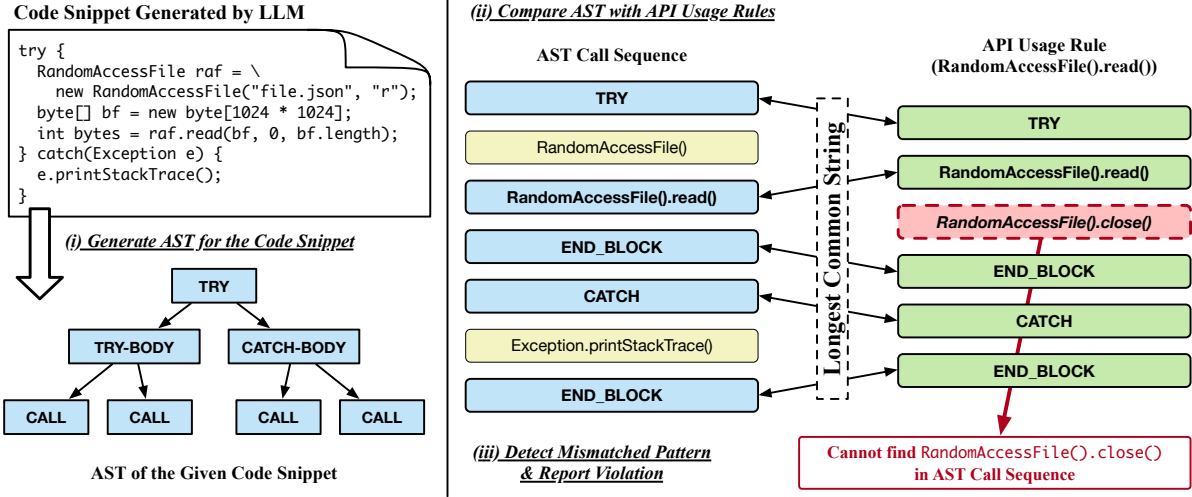

Figure 2: The Illustration of Our API Checker. The API checker uses the static analysis method and analyzes the generated code with the abstract syntax tree (AST). The API misuse is detected when the AST call sequence and the API usage rule do not match.

Detecting API Misuse

Existing research in evaluating the code generated by LLMs usually use test cases either written by human or by automatic test generation. However, this falls short when testing the reliability and robustness of code because even high-coverage test cases only cover the semantic correctness. It is hard to create the testing environment and unexpected input that can evaluate the reliability and robustness of the code, which however would happen when the code is deployed in production. To deal with this challenging problem, we use the method of static analysis, which analyze the code misuse by its code structure without running the tests. This guarantees a full coverage of the whole programs while provides higher efficiency compared to testing solutions.

To evaluate the API usage correctness in code, ROBUSTAPI detects the API misuses against the API usage rules by extracting call consequences and control structures from the code snippet, as shown in Figure 2. The code checker firstly check the code snippets to see whether it is a snippet of a method or a method of a class, so that it can enclose this code snippet and constructs abstract syntax tree (AST) from the code snippet. Then the checker traverses the AST to record all the method calls and control structures in order, which generate a call sequence. Next, the checker compare the call sequence against the API usage rules. It infers the instance type of each method calls and use the type and method as keys to retrieve corresponding API usage rules. Finally, the checker computes the longest common sequence between the call sequence and the API usage rules. If the call sequence does not match the expected API usage rules, the checker will report API misuses.

Experiment

Experiment Setup

In the experiments, we evaluate ROBUSTAPI on four LLMs: GPT-3.5 (OpenAI 2023a), GPT-4 (OpenAI 2023a), Llama-

2 (Touvron et al. 2023), Vicuna-1.5 (Chiang et al. 2023). The implementation details, including the checkpoints, the hyper-parameter, are included in Appendix due to the space limitation. We use the default hyper-parameter settings of each model without further extensive hyper-parameter tuning. For all models, we evaluate three experiment settings as introduced in Methodology:

- **Zero-shot:** No example is provided in the prompt. The prompt only contains the instruction, question.
- **One-shot-irrelevant:** ROBUSTAPI provides one example of a irrelevant task in the prompt.
- **One-shot-relevant:** ROBUSTAPI provides one example of the same API with the correct usage in the prompt.

The examples for shot generations are manually written and double-checked by the authors. Then they are evaluated against the API usage checkers to make sure they are aligned with the API usage rules.

Evaluation Metrics

To quantitatively evaluate the reliability of the generated code, we define the following values and our metrics are computed based on them. Supposing that we have N questions in our dataset, we divide them into three groups.

- N_{misuse} : The number of cases where our API usage checker detects the API usage violations.
- N_{pass} : The number of cases where our API usage checker does not detect the API usage violations.
- $N_{\text{non-exec}}$: The number of cases where the LLM fails to generated code or the generated code is not executable.

Based on the values, we define our metrics.

- **API Misuse Rate** = $N_{\text{misuse}} / (N_{\text{misuse}} + N_{\text{pass}})$: To analyze the proportion of misuse cases among the executable code snippets. It reveals how reliable the generated code is after the users filter out the non-executable cases.

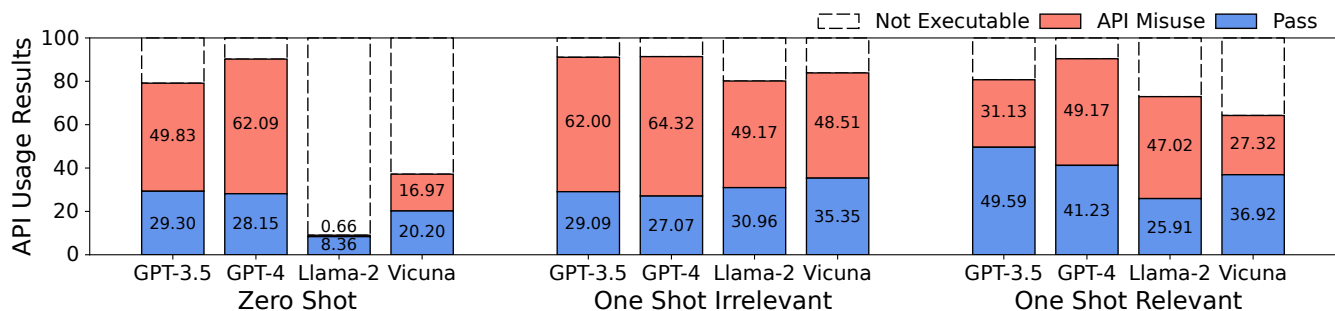

Figure 3: Result of Checking API Usage from LLMs. Red bars are the percentage of answers that contain API misuse, which is the *lower*, the *better*. The white bars in dot lines are the percentage of code answers that are not executable.

- **Executable Sample Percentage** = $(N_{\text{misuse}} + N_{\text{pass}}) / N$: To analyze the proportion of executable cases among all questions. It is necessary to consider the percentage of executable cases in order to eliminate the influence from the extreme situations, such as when only a few executable code snippets are generated.
- **Overall API Misuse Percentage** = N_{misuse} / N : To analyze the proportion of misuse cases among all questions.

Research Questions

We conduct a series of experiment on state-of-the-art LLMs based on ROBUSTAPI, which demonstrate the usability and effectiveness of ROBUSTAPI. The experiments provide insights on the ability of answering real-world coding questions, and the robustness and reliability of these answers regarding API misuse problem. In the experiment, we try to answer following questions:

- **Q1:** What are the API misuse rates in answering real-world coding questions by these LLMs?
- **Q2:** How do irrelevant shots affect the results?
- **Q3:** Can correct API usage examples reduce the misuse?
- **Q4:** Why does LLM-generated code fail the API usage check?

API Misuse Rate

Firstly, we present the API misuse rate of each models based on ROBUSTAPI in the left of Figure 3. In this figure, the higher the API misuse rate is, the worse of the code reliability and robustness for this large language model. The API misuse rate is calculated by dividing answers that can be compiled and contains API misuses by all the answers that can be compiled. From the evaluation results, all the evaluated models suffer from the API misuse problems, even for the state-of-the-art commercial models like GPT-3.5 and GPT-4. In zero-shot settings, Llama has the lowest API misuse rate. However, this is partially due to that most of Llama answers does not include any code. A counter-intuition finding is that GPT-4 actually has a higher API misuse rate than GPT-3.5, though the coding ability of GPT-4 is proved to be “40% more advanced than its predecessor, GPT-3.5” (OpenAI 2023b). This indicates that with the code generation

ability of large language models are largely improved nowadays, the reliability and robustness of code in real-world production rises as a unnoticed issue. And the space for improvement is huge for this problem.

Finding 1. *Answers to real-world coding questions from the state-of-the-art large language models widely have API misuse problems.*

One-Shot-Irrelevant Results

In this experiment, ROBUSTAPI gives a pair of question and answer as the example to show the model how to follow the template required by the instructions. The example contains no information that are relevant to the API usage checked by ROBUSTAPI. The result is shown in the middle of Figure 3. However, for most models, the irrelevant shot does not significantly reduce the API misuse rate but on the contrary slightly increase the misuse rate. One possible reason of this is the irrelevant shot provided to the large language models actually encourage the models to give a lengthy code solution, which increase the chance of API misuses. API misuse rate of Llama increases significantly after adding the irrelevant shot because it has more valid answers that contain code snippets. Overall, adding an irrelevant shot triggers the large language models to generate more valid answers, which enables a better evaluation on the code reliability and robustness.

Finding 2. *Among all the answers containing executable code, 57-70% of the code snippets in LLM answers contain API misuse, which could lead to severe consequence in production.*

Finding 3. *Irrelevant shot examples does not help decrease the API misuse rate but triggers more valid answers, which show to be effective for benchmarking the model performance.*

One-Shot-Relevant Results

In this experiment, ROBUSTAPI adds a manually-written shot in the prompt, which performs a different task but uses the same API. This gives hints to LLMs on how to use these APIs correctly. From the results, after adding the correct usage shot, the API misuse rates of GPT-3.5, GPT-4 and Vicuna significantly drop. This indicates a effective improve-

References

- Anil, R.; Dai, A. M.; Firat, O.; Johnson, M.; Lepikhin, D.; Passos, A.; Shakeri, S.; Taropa, E.; Bailey, P.; Chen, Z.; et al. 2023. Palm 2 technical report. *arXiv preprint arXiv:2305.10403*.
- Austin, J.; Odena, A.; Nye, M.; Bosma, M.; Michalewski, H.; Dohan, D.; Jiang, E.; Cai, C.; Terry, M.; Le, Q.; et al. 2021. Program synthesis with large language models. *arXiv preprint arXiv:2108.07732*.
- Chen, M.; Tworek, J.; Jun, H.; Yuan, Q.; Pinto, H. P. d. O.; Kaplan, J.; Edwards, H.; Burda, Y.; Joseph, N.; Brockman, G.; et al. 2021. Evaluating large language models trained on code. *arXiv preprint arXiv:2107.03374*.
- Chiang, W.-L.; Li, Z.; Lin, Z.; Sheng, Y.; Wu, Z.; Zhang, H.; Zheng, L.; Zhuang, S.; Zhuang, Y.; Gonzalez, J. E.; Stoica, I.; and Xing, E. P. 2023. Vicuna: An Open-Source Chatbot Impressing GPT-4 with 90%* ChatGPT Quality.
- Fischer, F.; Böttinger, K.; Xiao, H.; Stransky, C.; Acar, Y.; Backes, M.; and Fahl, S. 2017. Stack overflow considered harmful? the impact of copy&paste on android application security. In *2017 IEEE Symposium on Security and Privacy (SP)*, 121–136. IEEE.
- Fischer, G.; Lusiardi, J.; and Von Gudenberg, J. W. 2007. Abstract syntax trees-and their role in model driven software development. In *International Conference on Software Engineering Advances (ICSEA 2007)*, 38–38. IEEE.
- Hendrycks, D.; Basart, S.; Kadavath, S.; Mazeika, M.; Arora, A.; Guo, E.; Burns, C.; Puranik, S.; He, H.; Song, D.; et al. 2021. Measuring coding challenge competence with apps. *arXiv preprint arXiv:2105.09938*.
- Jesse, K.; Ahmed, T.; Devanbu, P. T.; and Morgan, E. 2023. Large Language Models and Simple, Stupid Bugs. *arXiv preprint arXiv:2303.11455*.
- Liu, J.; Xia, C. S.; Wang, Y.; and Zhang, L. 2023. Is your code generated by chatgpt really correct? rigorous evaluation of large language models for code generation. *arXiv preprint arXiv:2305.01210*.
- Lu, S.; Guo, D.; Ren, S.; Huang, J.; Svyatkovskiy, A.; Blanco, A.; Clement, C.; Drain, D.; Jiang, D.; Tang, D.; et al. 2021. Codexglue: A machine learning benchmark dataset for code understanding and generation. *arXiv preprint arXiv:2102.04664*.
- Luo, Z.; Xu, C.; Zhao, P.; Sun, Q.; Geng, X.; Hu, W.; Tao, C.; Ma, J.; Lin, Q.; and Jiang, D. 2023. WizardCoder: Empowering Code Large Language Models with Evol-Instruct. *arXiv preprint arXiv:2306.08568*.
- OpenAI. 2023a. GPT-4 Technical Report. *ArXiv*, abs/2303.08774.
- OpenAI. 2023b. GPT-4 Technical Report. *arXiv:2303.08774*.
- Pearce, H.; Ahmad, B.; Tan, B.; Dolan-Gavitt, B.; and Karri, R. 2022. Asleep at the keyboard? assessing the security of github copilot’s code contributions. In *2022 IEEE Symposium on Security and Privacy (SP)*, 754–768. IEEE.
- Perry, N.; Srivastava, M.; Kumar, D.; and Boneh, D. 2022. Do users write more insecure code with AI assistants? *arXiv preprint arXiv:2211.03622*.
- Poesia, G.; Polozov, O.; Le, V.; Tiwari, A.; Soares, G.; Meek, C.; and Gulwani, S. 2022. Synchromesh: Reliable code generation from pre-trained language models. *arXiv preprint arXiv:2201.11227*.
- Sandoval, G.; Pearce, H.; Nys, T.; Karri, R.; Garg, S.; and Dolan-Gavitt, B. 2023. Lost at c: A user study on the security implications of large language model code assistants. *arXiv preprint arXiv:2208.09727*.
- Shen, B.; Zhang, J.; Chen, T.; Zan, D.; Geng, B.; Fu, A.; Zeng, M.; Yu, A.; Ji, J.; Zhao, J.; et al. 2023a. PanGu-Coder2: Boosting Large Language Models for Code with Ranking Feedback. *arXiv preprint arXiv:2307.14936*.
- Shen, X.; Chen, Z.; Backes, M.; and Zhang, Y. 2023b. In chatgpt we trust? measuring and characterizing the reliability of chatgpt. *arXiv preprint arXiv:2304.08979*.
- Siddiq, M. L.; Majumder, S. H.; Mim, M. R.; Jajodia, S.; and Santos, J. C. 2022. An Empirical Study of Code Smells in Transformer-based Code Generation Techniques. In *2022 IEEE 22nd International Working Conference on Source Code Analysis and Manipulation (SCAM)*, 71–82. IEEE.
- Touvron, H.; Martin, L.; Stone, K.; Albert, P.; Almahairi, A.; Babaei, Y.; Bashlykov, N.; Batra, S.; Bhargava, P.; Bhosale, S.; et al. 2023. Llama 2: Open foundation and fine-tuned chat models. *arXiv preprint arXiv:2307.09288*.
- Yang, D.; Hussain, A.; and Lopes, C. V. 2016. From query to usable code: an analysis of stack overflow code snippets. In *Proceedings of the 13th International Conference on Mining Software Repositories*, 391–402.
- Ye, J.; Chen, X.; Xu, N.; Zu, C.; Shao, Z.; Liu, S.; Cui, Y.; Zhou, Z.; Gong, C.; Shen, Y.; et al. 2023. A comprehensive capability analysis of gpt-3 and gpt-3.5 series models. *arXiv preprint arXiv:2303.10420*.
- Yetistiren, B.; Ozsoy, I.; and Tuzun, E. 2022. Assessing the quality of GitHub copilot’s code generation. In *Proceedings of the 18th International Conference on Predictive Models and Data Analytics in Software Engineering*, 62–71.
- Yin, P.; Deng, B.; Chen, E.; Vasilescu, B.; and Neubig, G. 2018. Learning to mine aligned code and natural language pairs from stack overflow. In *Proceedings of the 15th international conference on mining software repositories*, 476–486.
- Zhang, T.; Upadhyaya, G.; Reinhardt, A.; Rajan, H.; and Kim, M. 2018. Are code examples on an online q&a forum reliable? a study of api misuse on stack overflow. In *Proceedings of the 40th international conference on software engineering*, 886–896.
- Zhou, J.; and Walker, R. J. 2016. API deprecation: a retrospective analysis and detection method for code examples on the web. In *Proceedings of the 2016 24th ACM SIGSOFT International Symposium on Foundations of Software Engineering*, 266–277.

Appendix

Rules Checked in ROBUSTAPI

The API usage patterns checked in ROBUSTAPI are shown in Table 3. It is summarized based on the existing research on API misuses (Zhang et al. 2018). Each pattern contains a sequence of control structures and method calls, separated by commas, which will be retrieved by the API usage checker and compare against the AST of code snippets.

To be more specific, `arg0` is a variable that indicates the first argument of the function call. `rcv` is also a variable corresponding to the object of the method call. `a@C` indicates that API `a` can only be invoked when condition `C` is satisfied.

For example, the pattern of `JsonElement.getAsString`:

```
try,getAsString()@rcv!=null,end,catch(Exception),end
```

indicates the API `JsonElement.getAsString` can be used only when the object of `getAsString()` is valid, and the API call should be enclosed within a try-catch block to handle potential exceptions.

More detailed explanation of each API usage rules is as follows.

1. **FileChannel.write:** Execute `write()` within a try-catch block to handle exceptions.
2. **FileChannel.write:** Execute `write()` within a try-catch for handling exceptions.
3. **FileChannel.write/close:** To execute `close()` after `write()`, handling exceptions.
4. **Activity.setContentView:** Ensure that `setContentView(View)` is called after `onCreate(Bundle)`.
5. **List.get:** Loop over the `get(int)` call while `arg0` is less than the instance's `size()`.
6. **RandomAccessFile.write/close:** Execute `close()` after execute `write(byte[])`, handling exceptions.
7. **PrintWriter.write:** Execute `write(String)` within try-catch for handling exceptions.
8. **PrintWriter.write/close:** Execute `close()` after `write(String)` within try-catch for handling exceptions.
9. **TypedArray.getString:** After calling `getString(int)`, make sure to call `recycle()`.
10. **StringTokenizer.nextToken:** Call `hasMoreTokens()` to check before calling `nextToken()`.
11. **Map.get:** Compare the return value of `get()`.
12. **File.createNewFile:** Execute `createNewFile()` within try-catch for handling exceptions.
13. **SQLiteDatabase.query:** After executing `query()`, make sure to call `close()`.
14. **JsonElement.getAsString:** Execute `getAsString()` within try-catch. Check the object is not null.
15. **JsonElement.getAsString:** Execute `getAsString()` within try-catch block. Check the object with `isJsonPrimitive()`.
16. **String.getBytes:** Execute `getBytes()` within try-catch for handling exceptions.
17. **ProgressDialog.dismiss:** Check the object of `dismiss()` against null.
18. **Cipher.init:** Execute `init()` within try-catch for handling exceptions.
19. **Cipher.init:** Execute `init()` before `getInstance()` and within try-catch for handling exceptions.
20. **File.mkdirs:** Call `exists()` before create a directory using `mkdirs()`.
21. **ApplicationInfo.loadIcon:** Execute `loadIcon()` within try-catch for handling exceptions.
22. **ApplicationInfo.loadIcon:** Call `getPackageManager()` before execute `loadIcon()`.
23. **BufferedReader.readLine:** Execute `readLine()` within try-catch for handling exceptions.
24. **BufferedReader.readLine:** Create a `BufferedReader` before execute `readLine()`.
25. **BufferedReader.readLine:** Create a `BufferedReader` before execute `readLine()` within try-catch for handling exceptions.
26. **BufferedReader.readLine:** Execute `readLine()` within try-catch and handle `Exception`.
27. **Iterator.next:** Call `next()` as long as the instance's `hasNext()` is true.

Table 3: API usage patterns checked in ROBUSTAPI.

API	Pattern
1 FileChannel.write	try, write(ByteBuffer), end, catch(Exception), end
2 FileChannel.write	try, getChannel(), write(ByteBuffer), end, catch(Exception), end
3 FileChannel.write/close	try, write(ByteBuffer), close(), end, catch(Exception), end
4 Activity setContentView	onCreate(Bundle), setContentView(View)
5 List.get	LOOP, get(int)@arg0<rcv.size(), end
6 RandomAccessFile.write/close	try, write(byte[]), close(), end, catch(Exception), end
7 PrintWriter.write	try, write(String), end, catch(Exception), end
8 PrintWriter.write/close	try, write(String), close(), end, catch(Exception), end
9 TypedArray.getString	getString(int), recycle()
10 StringTokenizer.nextToken	StringTokenizer.nextToken
11 Map.get	get(String), IF, end
12 File.createNewFile	try, createNewFile(), end, catch(Exception), end
13 SQLiteDatabase.query	query(String,String[],String,String[],String,String,String), close()
14 JsonElement.getAsString	try, getAsString()@rcv!=null, end, catch(Exception), end
15 JsonElement.getAsString	try, getAsString()@rcv.isJsonPrimitive(), end, catch(Exception), end
16 String.getBytes	getBytes(String)
17 ProgressDialog.dismiss	IF, dismiss()@rcv!=null, end
18 Cipher.init	try, init(int,Key), end, catch(Exception), end
19 Cipher.init	try, getInstance(String), init(int,Key), end, catch(Exception), end
20 File.mkdirs	exists(), mkdirs()
21 ApplicationInfo.loadIcon	try, loadIcon(PackageManager), end, catch(Exception), end
22 ApplicationInfo.loadIcon	getPackageManager(), loadIcon(PackageManager)
23 BufferedReader.readLine	try, readLine(), end, catch(Exception), end
24 BufferedReader.readLine	new BufferedReader(InputStreamReader), readLine()
25 BufferedReader.readLine	try, new BufferedReader(InputStreamReader), readLine(), end, catch(Exception), end
26 BufferedReader.readLine	try, readLine(), end, catch(IOException), end
27 Iterator.next	next()@rcv.hasNext()