

ALIGN WITH PURPOSE: OPTIMIZE DESIRED PROPERTIES IN CTC MODELS WITH A GENERAL PLUG-AND-PLAY FRAMEWORK

Eliya Segev* Maya Alroy* Ronen Katsir Noam Wies Ayana Shenhav Yael Ben-Oren

David Zar Oren Tadmor Jacob Bitterman Amnon Shashua Tal Rosenwein

OrCam Technologies LTD, Jerusalem, Israel

ABSTRACT

Connectionist Temporal Classification (CTC) is a widely used criterion for training supervised sequence-to-sequence (seq2seq) models. It enables learning the relations between input and output sequences, termed alignments, by marginalizing over perfect alignments (that yield the ground truth), at the expense of imperfect alignments. This binary differentiation of perfect and imperfect alignments falls short of capturing other essential alignment properties that hold significance in other real-world applications. Here we propose *Align With Purpose*, a **general Plug-and-Play framework** for enhancing a desired property in models trained with the CTC criterion. We do that by complementing the CTC with an additional loss term that prioritizes alignments according to a desired property. Our method does not require any intervention in the CTC loss function, enables easy optimization of a variety of properties, and allows differentiation between both perfect and imperfect alignments. We apply our framework in the domain of Automatic Speech Recognition (ASR) and show its generality in terms of property selection, architectural choice, and scale of training dataset (up to 280,000 hours). To demonstrate the effectiveness of our framework, we apply it to two unrelated properties: emission time and word error rate (WER). For the former, we report an improvement of up to 570ms in latency optimization with a minor reduction in WER, and for the latter, we report a relative improvement of 4.5% WER over the baseline models. To the best of our knowledge, these applications have never been demonstrated to work on a scale of data as large as ours. Notably, our method can be implemented using only a few lines of code¹, and can be extended to other alignment-free loss functions and to domains other than ASR.

1 INTRODUCTION

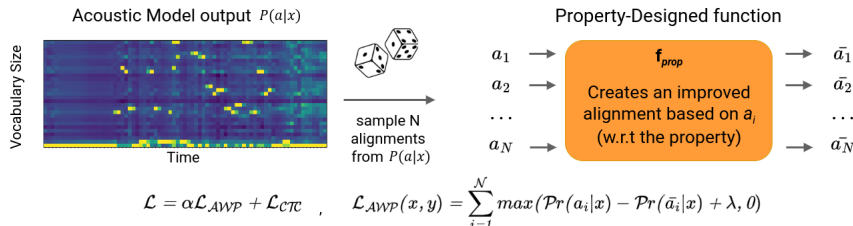

Figure 1: The Align With Purpose flow: N alignments are sampled from the output of a pre-trained CTC model, on which f_{prop} is applied, to create N pairs of alignments. Then, hinge loss with an adjustable weight is applied on the probabilities of each pair of alignments, trained jointly with a CTC loss. see full details in section 2.2

Sequence-to-sequence (seq2seq) tasks, in which the learner needs to predict sequence of labels from unsegmented input data, are prevalent in various domains, e.g. handwriting recognition (Graves & Schmidhuber, 2008), automatic speech recognition (Collobert et al., 2017; Hannun et al., 2014),

*Equally contributed. email: {first.last}@orcaml.com

¹The code will be made publicly available in the supplementary materials.

audio-visual speech recognition (Afouras et al., 2022), neural machine translation (Huang et al., 2022), and protein secondary structure prediction (Yang et al., 2022), to name a few. For many years, the segmentation issue was a bottleneck as finding the input-output relations, termed alignments, is the most difficult aspect of many seq2seq tasks (Graves, 2012).

Two main approaches were introduced to overcome the absence of explicit supervision of the input segmentation, namely soft and hard alignment. Soft alignment methods use attention mechanism (Chan et al., 2016; Vaswani et al., 2017) that softly predict the alignment using attention weights, while hard alignment methods learn in practice an explicit alignment (Graves et al., 2006; Graves, 2012; Collobert et al., 2017), by marginalizing over all alignments that create the ground truth labels.

As streaming audio and video become prevalent (Cisco, 2018), architectures that can work in a streaming fashion gain attention. Although soft alignment techniques can be applied in chunks for streaming applications (Bain et al., 2023), their implementation is not intuitive and less computationally efficient compared to hard alignment methods, which are naturally designed for streaming processing. Among the hard alignment methods, the CTC criterion (Graves et al., 2006) is a common choice due to its simplicity and interpretability. During training, CTC minimizes the negative log-likelihood of the ground truth (GT) sequence. To overcome the segmentation problem, CTC marginalizes over all possible input-GT output pairings, termed perfect alignments. This is done using an efficient and differentiable forward-backward algorithm, which is the core algorithm in CTC. Note that Zeyer et al. (2021) and Tian et al. (2023a) showed that the CTC posteriors tend to be peaky, and hence the posterior of one certain alignment is dominant over all others. Thus, as a by product, in practice CTC learns to predict an alignment without a direct supervision related to the alignment,

While convenient, the implicit alignment learning comes with the cost of inability to control desired properties of the learned alignment. This can be explained by the inherent nature of CTC that marginalizes solely over all perfect alignments. Therefore, the CTC does not induce further prioritization between perfect alignments, nor does it prioritize between imperfect alignments.

However, many real-world seq2seq applications may come with a property that induces, and sometimes requires, such prioritization. For example, in the contexts of ASR and OCR, a standard metric to test the quality of the system is the word error rate (WER). Therefore, prioritizing imperfect alignments with low WER can improve the performance of a system measured by this metric, and by that reduce the gap between the training and the testing criteria (Graves & Jaitly, 2014). Another example is a low-latency ASR system. Here, even a perfect CTC score can only guarantee a perfect transcription while completely ignoring the latency of the system. Clearly, under this setting, for an application that requires fast response, prioritizing alignments with fast emission time is crucial. Figure 2 visualizes the above mentioned properties.

Table 1: CTC score is not a good proxy for WER and latency of a system. Results shown on LibriSpeech test clean.

ASR Model Type	CTC Score	WER (%)	Latency (ms)
Offline	0.0033	4.28	0
Online	0.003	5.43	217

To exemplify the importance of prioritization, Table 1 shows that a CTC score is not a good proxy for some properties of the output alignment. It shows two different models with a similar training loss that have different WER and emission time, although trained on the same data. In general, there are many other properties that also necessitate prioritization between alignments, whether perfect or imperfect.

A similar phenomenon, where some property remains indistinguishable based on the training criteria, was also observed with the maximum likelihood criterion in natural language processing (NLP) domain. More specifically, Liu et al. (2022) suggested BRIO, a simple and elegant mitigation technique, that achieved state-of-the-art results in abstraction text summarization, overcoming the challenge of multiple ground-truths. Essentially, this technique adds an additional loss term that prioritizes sequences that have a high ROUGE (Lin, 2004) score.

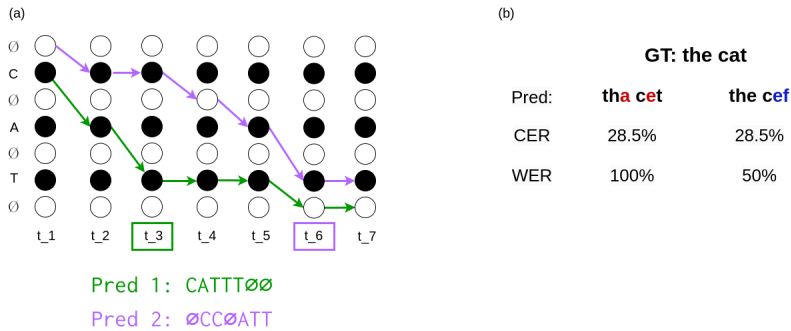

Figure 2: A visualization of two properties that are not captured by CTC. (a) Emission Time: Two alignments that yield the same text, but the green alignment emits the last token of CAT at timestamp 3 (t_3) while the purple alignment emits it at t_6. (b) Word-Error-Rate: two imperfect predictions with the same CER but different WER.

To complement the CTC with additional prioritization between alignments, we aim to control the learned alignments by taking inspiration from BRIO. To achieve such controllability, we propose *Align With Purpose (AWP)* - a **Plug-and-Play framework**, which allows enhancing a given property in the outputs of models that are trained using the CTC criterion, while maintaining the transcription abilities of the model. We add an additional loss term, L_{AWP} , that expresses a more subtle differentiation between alignment, so that the final loss becomes $L = L_{CTC} + \alpha L_{AWP}$. Specifically, for a given property, we design a function f_{prop} that receives an alignment as an input, and outputs an improved alignment, with respect to the property. Then, we sample N alignments based on the output probabilities of the pre-trained CTC model, apply f_{prop} on the sampled alignments, to create N pairs of alignments. Finally, we calculate the L_{AWP} using hinge loss over the N pairs, thus encouraging the model to increase the probability mass of the preferable alignments, as described in Figure 1. Our work can be seen as an extension of BRIO to the CTC case, in which we aim to control properties unrelated to the diversity of the target distribution.

The controllability goal for hard alignment criteria (such as CTC) was suggested in prior work, where many of these solutions involve intervention in the forward-backward algorithm (Tian et al., 2023a; Yu et al., 2021; Shinohara & Watanabe, 2022; Yao et al., 2023; Laptev et al., 2023). As a consequence, these methods do not allow to address the imperfect alignments, unlike AWP which supports it naturally. Additionally, this intervention requires good engineering and consumes a considerable amount of development time and optimization. Other methods that do address the imperfect alignments such as (Prabhavalkar et al., 2018; Graves & Jaitly, 2014) still suffer from the latter, unlike AWP which can be implemented using few lines of code.

To summarize, our main contributions are:

1. Align With Purpose - a simple and general Plug-and-Play framework to enhance a general property in the outputs of a CTC model.
2. We show promising results in two properties that are independent of each other: we report an improvement of up to 570ms in latency optimization, and a relative improvement of 4.5% WER over the baseline models for the minimum WER optimization.
3. We show the generality of our framework in terms of property selection, scale of training dataset, and architectural choice. To the best of our knowledge, these applications have never been demonstrated to work on a scale of data as large as ours.
4. The framework enables prioritization between perfect alignment, as well as between imperfect alignments.

We apply our approach to the ASR domain, specifically to models that are trained with CTC criterion. However, this method can be extended to other alignment-free objectives, as well as to other domains besides ASR.

2 CTC AND ALIGN WITH PURPOSE

The outline of this section is as follows: We will start with a description of the CTC loss in subsection 2.1, followed by a detailed explanation of the proposed "Align With Purpose" method in subsection 2.2, and finally we will showcase two applications: low latency in subsection 2.3 and mWER in subsection 2.4.

2.1 CTC

The Connectionist Temporal Classification criterion (Graves et al., 2006) is a very common choice for training seq2seq models, as it does not require input segmentation, i.e., frame-level alignment between transcript and audio pairs. To relax the requirement of segmentation, an extra blank token \emptyset that represents a null emission is added to the vocabulary V , so that $V' = V \cup \{\emptyset\}$.

Given a T length input sequence $\mathbf{x} = [x_1, \dots, x_T]$ (e.g. audio), the model outputs T vectors $\mathbf{v}_t \in \mathbb{R}^{|V'|}$, each of which is normalized using the softmax function, where \mathbf{v}_t^k can be interpreted as the probability of emitting the token k at time t . An alignment \mathbf{a} is a T length sequence of tokens taken from V' , and $P(\mathbf{a}|\mathbf{x})$ is defined by the product of its elements:

$$P(\mathbf{a}|\mathbf{x}) = \prod_{t=1}^T p(\mathbf{a}_t|\mathbf{x}). \quad (1)$$

The probability of a given target sequence \mathbf{y} (e.g. text) of length U , $\mathbf{y} = [y_1, \dots, y_U]$ where $U \leq T$, is the sum over the alignments that yield \mathbf{y} :

$$P(\mathbf{y}|\mathbf{x}) = \sum_{\mathbf{a}:\mathbf{a} \in \mathcal{B}^{-1}(\mathbf{y})} p(\mathbf{a}|\mathbf{x}), \quad (2)$$

where \mathcal{B} is the collapse operator that first removes repetition of tokens and then removes blank symbols.

The CTC objective function is to minimize the negative log-likelihood of the alignments that yield \mathbf{y} , as seen in Eq. 3

$$L_{CTC}(\mathbf{x}) = -\log P(\mathbf{y}|\mathbf{x}). \quad (3)$$

Therefore, by definition, the CTC criterion only takes into account perfect alignments, meaning that all imperfect alignments are equally bad as stated in Graves & Jaitly (2014). In addition, the CTC criterion does not prioritize between perfect alignments, as they are equally good as stated in Tian et al. (2023a).

2.2 ALIGN WITH PURPOSE

In this section, we present Align With Purpose (AWP), a method that aims to overcome the lack of controllability by the CTC criterion. AWP complements the CTC loss with an additional loss term that enables more subtle differentiation between alignments. Importantly, AWP is a general Plug-and-Play framework for enhancing a desired property in models trained with the CTC criterion, while maintaining the seq2seq capabilities of the model.

Specifically, given a desired property to enhance, one needs to design a property-specific function f_{prop} , that takes an alignment \mathbf{a} and improves it to obtain $\bar{\mathbf{a}}$, which is considered better w.r.t the property. During training, we sample random alignments according to the distribution induced by the output of the seq2seq model. Then we apply f_{prop} on the random alignments, to obtain $\bar{\mathbf{a}}$. Finally we prioritize $\bar{\mathbf{a}}$ over \mathbf{a} by applying hinge loss on their probabilities. See Fig. 1 for illustration of the proposed framework. As pointed out in previous works (Graves & Jaitly, 2014; Prabhavalkar et al., 2018), sampling from a randomly initialized model is less effective, as the outputs are completely random. Therefore, we train the model to some extent with a CTC loss as in Eq. 3, and proceed training with the proposed method.

Formally, we define the property-specific function that takes as input an alignment and returns an alignment with the same length: $f_{prop} : V^{T'} \rightarrow V^{T'}$. Then, at each training step we sample N random alignments according to the distribution induced by the output of the seq2seq model, such that $\mathbf{a}_t^i \sim \mathbf{v}_t$ for $t \in [1..T]$ and $i \in [1..N]$. We then apply $\bar{\mathbf{a}}^i = f_{prop}(\mathbf{a}^i)$ to obtain better alignments. This creates N pairs of alignments $(\mathbf{a}^i, \bar{\mathbf{a}}^i)$, such that \mathbf{a}^i is the least favored in each pair. Finally, to enhance the desired property we encourage the model to increase the probability mass of $\bar{\mathbf{a}}^i$, by applying hinge loss on the alignment pairs:

$$L_{AWP}(x) = \frac{1}{N} \sum_{i=1}^N \max\{P(\mathbf{a}^i|x) - P(\bar{\mathbf{a}}^i|x) + \lambda, 0\}, \quad (4)$$

where λ is the margin determined on a validation set.

To enable differentiation during the sampling process, we utilize Gumbel-Softmax sampling, as proposed by Jang et al. (2017).

Putting it all together, the training loss then becomes:

$$L(x) = L_{CTC}(x) + \alpha L_{AWP}(x), \quad (5)$$

where α is a tunable hyper-parameter that controls the trade-off between the desired property and the CTC loss.

2.3 APPLICATIONS: LOW LATENCY

Streaming ASR systems with low latency is an active research field, as it serves as a key component in many real world applications such as personal assistants, smart homes, real-time transcription of meetings, etc. (Song et al., 2023). To measure the overall latency of a system, three elements should be taken into account: data collection latency (**DCL**) which is the future context of the model, drift latency (**DL**), and computational latency (**CL**), as defined by Tian et al. (2023a). We leave the CL component out of the scope of this work, as it sensitive to architectural choice, hardware, and implementation. Thus, we denote by **TL=DCL+DL** the total latency of the system.

Several techniques were suggested to reduce the TL: input manipulation (Song et al., 2023), loss modification (Tian et al., 2023a), loss regularization (Yu et al., 2021; Yao et al., 2023; Shinohara & Watanabe, 2022; Tian et al., 2023b), and architectural choice (Pratap et al., 2020). These methods were specific to the low latency settings, or required intervention in the forward-backward algorithm, unlike AWP which is a general plug-and-play method.

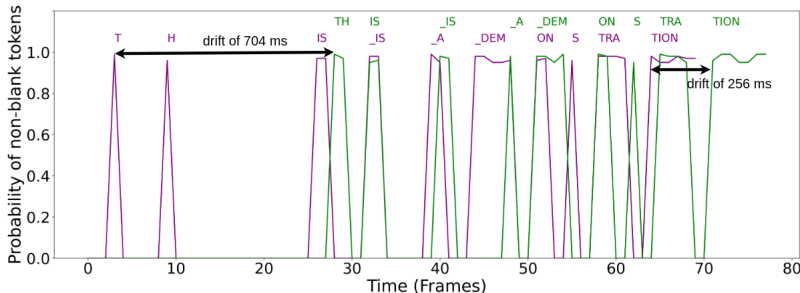

Figure 3: Drift in emission time in CTC model. Bottom purple text: An offline stacked resnet model with symmetric padding, and future (and past) context of 3.2 seconds. Top green text: An online stacked resnet with assymetric padding, with 430ms future context and 5.97 seconds past context. It can be seen that the output of the online model has a drift of more that 200 ms.

One way to reduce the DCL, is by limiting the future context of the model. In attention based models it can be achieved by left context attention layers (Yu et al., 2021), and in convolutional NN it can be achieved using assymetrical padding (Pratap et al., 2020). However, Pratap et al. (2020) have shown that training with limited future context results in a drift (delay) in the emission time of tokens (DL), as can be seen in Fig. 3. The cause of the drift was explained by Wang et al. (2020), who made the



Figure 4: Defining $f_{low_latency}$. To obtain \bar{a} , we shift the sampled alignment a one token to the left, starting from a random position (second char in this example) within the alignment, and pad \bar{a} with a trailing blank symbol, marked by a black rectangle

observation that less future context deteriorates performance. Therefore, by delaying the emission time, the model effectively gains more context, which in turn improves the performance.

To apply AWP for mitigating the drift effect (DL), given an alignment a , we sample a random position within it, and shift a one token to the left from that position, to obtain \bar{a} as seen in Fig. 4. Clearly, tokens emission time of \bar{a} is one time step faster than a , from the random position and on. By limiting the initial shift position to correspond to tokens that are repetitions, we ensure that the collapsed text of \bar{a} remains the same as a . To make \bar{a} a T length alignment, we pad it with a trailing blank symbol.

Formally, we define the function $f_{low_latency}$. Given an alignment a , define the subset of indices $[j_1, \dots, j_{T'}] \subseteq [2..T]$ as all the indices such that $a_{j_k} = a_{j_k-1}$, meaning that a_{j_k} is a repetition of the previous token. Then we sample a random position j from $[j_1, \dots, j_{T'}]$, and obtain \bar{a} in Eq. 6:

$$\bar{a}_t = \begin{cases} a_t & \text{if } t < j - 1 \\ a_{t+1} & \text{if } j - 1 \leq t < T \\ \emptyset & \text{if } t == T \end{cases} \quad (6)$$

2.4 APPLICATIONS: MINIMUM WORD ERROR RATE

The most common metric to asses an ASR system is the word error rate (WER). As pointed out by Graves & Jaitly (2014), there’s a gap between the training and testing criteria, as the CTC objective function does not prioritize between imperfect alignments. Therefore, it could improve the system’s performance to add such prioritization w.r.t their WER. Prior work addressed this issue. Graves & Jaitly (2014) suggested to approach it by minimizing the expected WER, and Prabhavalkar et al. (2018) suggested a similar objective for training with the cross entropy (CE) loss.

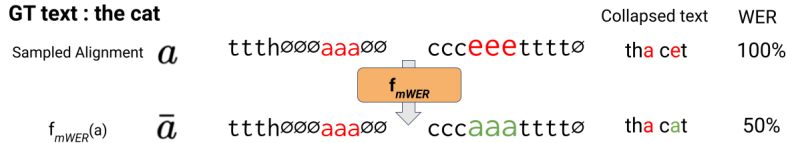

Figure 5: Defining f_{mWER} . Given a target transcription 'the cat', the (upper) sampled alignment yields the text 'tha cet', which has 100% WER. Substituting the occurrences of the token 'e' with the token 'a' produces the text 'tha cat', which has 50% WER.

As illustrated in Figure 5, to apply AWP for minimum WER (mWER) training, we define f_{mWER} . Given a sampled **imperfect** alignment a and a ground truth transcription y , to obtain \bar{a} , we select the word in the collapsed text $\mathcal{B}(a)$ which requires the minimum number of substitutions to correct. Then we fix the alignment of this word according to the ground truth, so that the number of word errors in $\mathcal{B}(\bar{a})$ is smaller by 1.

3 EXPERIMENTAL SETUP

Our proposed framework is evaluated on two end-tasks: low latency and mWER, by conducting experiments using multiple architectures and different scales of datasets. General settings are de-

tailed in Sec. 3.1, Sec. 3.2 describes the low latency experiment, and Sec. 3.3 describes the mWER experiment.

3.1 GENERAL SETTINGS

Datasets. To examine our framework on different scales of data, we train on small, medium, and large scale datasets.

For the small scale, we train models on the LibriSpeech dataset (Panayotov et al., 2015), which consists of 960 training hours (LS-960). For the medium scale, we train models on a 35K hours curated subset of LibriVox² (LV-35K), where samples with low confidence of a reference model were filtered out. For the large scale, we train models on an internal dataset of 280K hours of audio-transcript pairs (Internal-280K), which is, to the best of our knowledge, the largest dataset that was used to train either a low-latency model, or a model aiming directly to reduce the WER. We test our framework on the test splits of LibriSpeech. Audio is sampled at 16KHz, 16 bits/sample.

Architecture. We trained Stacked ResNet and Wav2Vec2 models (Baevski et al., 2020b).

We used a pretrained version of the base Wav2Vec2 model (90M parameters) available on Hugging-Face³. The model was pre-trained for 30 epochs on the 100K hours from VoxPopuli dataset (Wang et al., 2021). The model receives the raw audio as an input, and outputs 29 English lower-case characters, including apostrophe, space, and blank tokens.

Regarding the Stacked ResNet model, we extracted 80-channel Mel filter-banks features computed from a 32ms window with a stride of 16ms. For each frame, we stacked the filter banks with a first and second derivatives, resulting in a 240 dimensional input vector. We down-sample the audio input from 16ms to 32ms by applying MaxPool layer within the first layer of the first Stacked ResNet block, then stacked 20 ResNet blocks (He et al., 2016) with kernel size of 5. Skip connections are added every 4 ResNet blocks. The head of the model results in 29 English lower-case characters, including apostrophe, space, and blank tokens. The model consists of 66M parameters in total. This architecture induces a 6.4 seconds of context in total. Results shown are using an exponential moving average (EMA) model, which is aggregated alongside the model.

Decoding. Models were decoded using an in-house implementation of a beam search decoder described in (Graves & Jaitly, 2014), using a beam size of 100, and two language models: an open-source 5-gram language model⁴ (WordLM) trained on the Librispeech LM corpus, and a character-level language model (CharLM) that we trained on the same corpus. The beam search picks transcriptions y which maximize the quantity $L(y)$ defined by:

$$L(y) = P_{acoustic}(y|x) + \beta P_{CharLM}(y) + \gamma P_{WordLM}(y) \quad (7)$$

where $\beta = 0.8$ and $\gamma = 0.8$ are the CharLM and WordLM weights, respectively.

Text Normalization. We used an in-house implementation of text normalization to remain in a vocabulary of 29 English characters.

Sampling Method. To make the sampling process differentiable, we applied Gumbel-Softmax (Jang et al., 2017) during the sampling of alignments. Empirically, the Gumbel-softmax had no effect on results.

Training. To test the effectiveness of AWP, we train the models for several steps, and then apply our framework, namely adding the AWP loss to the CTC loss as stated in Eq. 5. The epoch in which we start to apply our framework is denoted as 'start epoch' in tables 2, 3. We repeated this process several times, each time with a different 'start epoch'.

3.2 LOW LATENCY

Architecture. All experiments (online and offline models) detailed in this section are conducted with a Stacked ResNet architecture mentioned in Sec. 3.1. This architecture can be implemented in

²<http://www.openslr.org/94/>

³<https://huggingface.co/facebook/wav2vec2-base-100k-voxpathuli>

⁴<https://www.openslr.org/11/>

a streaming manner and can be highly optimized for edge devices. Therefore, it’s a natural choice for a system that works in an online fashion in a low resources environment.

The offline model has 6.4 seconds of context in total, divided equally between past and future contexts. Although the model can be implemented in a streaming fashion, it would have a very large (3.2s) latency, due to its generous future context. The online model has a similar architecture and total context, but only 430 ms of the context relates to the future, which can be achieved by asymmetric padding as suggested in (Pratap et al., 2020). The small future context of the model makes it feasible to deploy as a streaming online ASR system.

Measuring DL. Measuring the DL of the online models is relative to the offline model. To measure the DL, we force-align the target (GT) transcript of the offline and online models independently and compare the first appearance of each token in the two force-aligned texts. Then, we take the average difference between the occurrences.

Training. When training AWP on LS-960, LV-35K, and Internal-280K, the hyper-parameters α and λ were set to 0.001, 0.001, 0.0005 and 0.01, 0, 0, respectively.

RAdam optimizer (Liu et al., 2020) with $\alpha = 0.9$, $\beta = 0.999$, and weight decay of 0.0001 was used. We set the LR to 0.001, with a ReduceLROnPlateau scheduler⁵. Models were trained for 20 epochs on LS-960 (small scale), 3 epochs on LV-35K (medium scale), and 1 epochs on Internal-280K (large scale).

3.3 MINIMUM WORD ERROR RATE

Architecture. In this setting, to verify that our framework is not architecture-specific, we trained Stacked ResNet model, as well as a Wav2Vec2 model as described in Sec. 3.1. The Stacked Resnet model that was used for enhancing mWER property is the same as the offline model described in subsection 3.2.

Training. The baseline Stacked Resnet model was pre-trained on the Internal-280K dataset. Then we continue its training solely on LS-960 for 4.3 epochs before we apply AWP. The AWP hyper-parameters were $\alpha = 0.1$, $\lambda = 0$. The baseline and the model with AWP were trained for 4.2 additional epochs, reaching 8.5 epochs in total. We used the RAdam optimizer (Liu et al., 2020) with the same hyper parameters as in Sec. 3.2.

The Wav2Vec2 baseline model was finetuned with SpecAugment (Park et al., 2019) (with $p=0.05$ for time masking and $p=0.0016$ for channel masking) solely on LS-960 for 2.3 epochs before we applied AWP, and both the baseline and the AWP models were trained for another 27.5 epochs. We used the Adam optimizer (Kingma & Ba, 2015) for this training, as well as a flat learning rate (LR) scheduler Baevski et al. (2020a). AWP hyper-parameters were set to $\alpha = 0.05$, $\lambda = 0$.

While training all models with AWP, we used a softmax temperature of 0.5 for the sampling of the N alignments.

4 RESULTS

In this section we present the results achieved by training using Align With Purpose framework on the low latency and mWER applications mentioned earlier.

4.1 LOW LATENCY

Table 2 shows the results when training on small, medium and large scales of data. We can see a clear trend across all scales where the AWP training successfully decreases the DL. More than that, it even manage to achieve a negative DL, thus decreasing the TL below the maximal TL expected by the architectural choice. In most cases, achieving such low TL solely by reducing the architectural future context using another padding optimization would not have been possible.

⁵https://pytorch.org/docs/stable/generated/torch.optim.lr_scheduler.ReduceLROnPlateau.html

In almost all the experiments, the WER increases with the latency reduction. This is a known trade-off between latency and accuracy as reported in prior work (Pratap et al., 2020). The choice of the operating point in terms of the balance between latency and accuracy can be determined by the weight of the AWP loss, α , and the scheduling of when we add the AWP loss ('start epoch').

We can also see that as the scale of the data increases, the WER decreases. This statement holds independently for the offline models and for the online models, and remains valid also after adding the AWP loss. This shows that AWP does not affect the ability of the model to improve its basic transcription capabilities using larger scales of data, which aligns with previous observations on large scale training Baevski et al., 2020a; Radford et al., 2022.

Table 2: Low Latency model training w/ & w/o AWP on different scales of data. results on Libri Test-Clean. Offline and online models have 3.2Kms and 430ms DCL, respectively. 'Start Epoch' denotes the step that we added AWP

Model	Training Data	Start Epoch	DL (ms)	TL (ms)	WER
Offline	LS-960	-	0	3.2K	3.55
Online	LS-960	-	221	651	4.06
+AWP	LS-960	9	-82	348	4.1
+AWP	LS-960	3.6	-104	326	4.13
Offline	LV-35K	-	0	3.2K	2.54
Online	LV-35K	-	345	775	2.91
+AWP	LV-35K	2.2	-130	300	3.43
+AWP	LV-35K	0.1	-225	205	3.51
Offline	Internal-280K	-	0	3.2K	2.34
Online	Internal-280K	-	200	540	2.89
+AWP ⁶	Internal-280K	5.7	60	400	2.62

4.2 MINIMUM WORD ERROR RATE

Table 3 shows a significant relative improvement of 4-4.5% in Word Error Rate (WER) when using AWP. This enhancement demonstrates the effectiveness of AWP in enhancing ASR performance.

Moreover, we observe that the degree of improvement is influenced by the difficulty level of the benchmark. As the benchmark becomes more challenging, the gain achieved by our method becomes more pronounced.

Furthermore, our proposed framework proves to be versatile, as it successfully operates on both streaming (Stacked ResNet) and offline (Wav2Vec2) architectures. The ability of our approach to adapt to different architectures highlights its applicability across various ASR systems.

Table 3: minimum WER model training w/ & w/o AWP. 'Start Epoch' denotes the step that we added AWP

Model	Start Epoch	% WER Libri Test-Clean (% Relative improvement)	% WER Libri Test-Other (% Relative improvement)
Stacked ResNet	-	2.63	7.46
+AWP	4.3	2.57 (2.2)	7.16 (4)
Wav2Vec	-	2.3	5.7
+AWP	2.3	2.25 (2.2)	5.44 (4.5)

⁶model is still training

5 DISCUSSION & FUTURE WORK

The results obtained from our study provide valuable insights regarding the potential for improvement in ASR models trained with CTC criterion. Although not tested, this framework could be easily applied to other hard-alignment criteria such as Transducer (Graves, 2012). Furthermore, by adapting and extending the concepts from our framework, it may be possible to enhance soft-alignment methods, even in domains beyond ASR.

In addition, an intriguing aspect for future research is the formalization of the properties that can be enhanced using Align With Purpose. By establishing a formal framework, researchers can systematically identify, define, and prioritize the properties to be enhanced. This can lead to targeted improvements and a deeper understanding of the impact of different properties on ASR performance. Finally, our study showcases the capability of enhancing a single property at a time. In some applications, multiple properties should be enhanced simultaneously, potentially leading to better performance.

6 LIMITATION & BROADER IMPACT

Although the AWP framework is relatively easy to use, its main limitation is that one needs to think carefully about the property function f_{prop} . When done in an elegant fashion, the implementation is straight forward.

The proposed AWP framework enables one to enhance a desired property of an ASR model trained with CTC. As mentioned in 5, this method can be applied or adapted to domains other than ASR. On the choice of the property to enhance, especially in generative AI, one should be thoughtful not to increase bias, malicious or racist content of models.

7 CONCLUSIONS

The binary differentiation of CTC between perfect and imperfect alignments highlights its limitation in capturing additional alignment properties, which is a key-requirement in many real-world applications. To overcome this limitation, we introduce Align With Purpose, a general Plug-and-Play framework designed to enhance specific properties in models trained using the CTC criterion. Our experimental results demonstrate promising outcomes in two key aspects: latency and minimum Word Error Rate (WER) optimization. Importantly, these optimizations are independent of each other, highlighting the versatility of our framework. The reduced latency achieved by our approach indicates faster transcription while maintaining transcription quality even with significantly reduced drift. Furthermore, using minimum WER (mWER) training emphasizes the importance of incorporating imperfect alignments, further enhancing the transcription quality of CTC systems. One of the strengths of our framework lies in its generality. It offers flexibility in selecting specific alignment properties, applies to large-scale training datasets, and is versatile to architectural choice. Our method does not require modifications to the CTC loss function and can be implemented using only a few lines of code.

REFERENCES

- Triantafyllos Afouras, Joon Son Chung, Andrew Senior, Oriol Vinyals, and Andrew Senior. Deep audio-visual speech recognition. *IEEE Transactions on Pattern Analysis and Machine Intelligence*, 44(12):8717–8727, dec 2022. doi: 10.1109/tpami.2018.2889052. URL <https://doi.org/10.1109%2Ftpami.2018.2889052>.
- Alexei Baevski, Henry Zhou, Abdelrahman Mohamed, and Michael Auli. wav2vec 2.0: A framework for self-supervised learning of speech representations, 2020a.
- Alexei Baevski, Yuhao Zhou, Abdelrahman Mohamed, and Michael Auli. wav2vec 2.0: A framework for self-supervised learning of speech representations. In H. Larochelle, M. Ranzato, R. Hadsell, M.F. Balcan, and H. Lin (eds.), *Advances in Neural Information Processing Systems*, volume 33, pp. 12449–12460. Curran Associates, Inc.,

- 2020b. URL https://proceedings.neurips.cc/paper_files/paper/2020/file/92d1e1eblcd6f9fba3227870bb6d7f07-Paper.pdf.
- Max Bain, Jaesung Huh, Tengda Han, and Andrew Zisserman. Whisperx: Time-accurate speech transcription of long-form audio. *INTERSPEECH 2023*, 2023.
- William Chan, Navdeep Jaitly, Quoc V. Le, and Oriol Vinyals. Listen, attend and spell: A neural network for large vocabulary conversational speech recognition. In *ICASSP*, 2016. URL <http://williamchan.ca/papers/wchan-icassp-2016.pdf>.
- Cisco. Vni complete forecast highlights, 2018. URL https://www.cisco.com/c/dam/en_us/solutions/service-provider/vni-forecast-highlights/pdf/Global_Device_Growth_Traffic_Profiles.pdf.
- Ronan Collobert, Christian Puhrsch, and Gabriel Synnaeve. Wav2letter: an end-to-end convnet-based speech recognition system, 2017. URL <https://openreview.net/forum?id=BkUDvt5gg>.
- Alex Graves. Sequence transduction with recurrent neural networks, 2012.
- Alex Graves and Navdeep Jaitly. Towards end-to-end speech recognition with recurrent neural networks. In Eric P. Xing and Tony Jebara (eds.), *Proceedings of the 31st International Conference on Machine Learning*, volume 32 of *Proceedings of Machine Learning Research*, pp. 1764–1772, Beijing, China, 22–24 Jun 2014. PMLR. URL <https://proceedings.mlr.press/v32/graves14.html>.
- Alex Graves and Jürgen Schmidhuber. Offline handwriting recognition with multidimensional recurrent neural networks. In D. Koller, D. Schuurmans, Y. Bengio, and L. Bottou (eds.), *Advances in Neural Information Processing Systems*, volume 21. Curran Associates, Inc., 2008. URL https://proceedings.neurips.cc/paper_files/paper/2008/file/66368270ffd51418ec58bd793f2d9b1b-Paper.pdf.
- Alex Graves, Santiago Fernández, Faustino Gomez, and Jürgen Schmidhuber. Connectionist temporal classification: labelling unsegmented sequence data with recurrent neural networks. In *Proceedings of the 23rd international conference on Machine learning*, pp. 369–376, 2006.
- Awni Hannun, Carl Case, Jared Casper, Bryan Catanzaro, Greg Diamos, Erich Elsen, Ryan Prenger, Sanjeev Satheesh, Shubho Sengupta, Adam Coates, and Andrew Y. Ng. Deep speech: Scaling up end-to-end speech recognition, 2014.
- K. He, X. Zhang, S. Ren, and J. Sun. Deep residual learning for image recognition. In *2016 IEEE Conference on Computer Vision and Pattern Recognition (CVPR)*, pp. 770–778, Los Alamitos, CA, USA, jun 2016. IEEE Computer Society. doi: 10.1109/CVPR.2016.90. URL <https://doi.ieeecomputersociety.org/10.1109/CVPR.2016.90>.
- Chenyang Huang, Hao Zhou, Osmar R Zaiane, Lili Mou, and Lei Li. Non-autoregressive translation with layer-wise prediction and deep supervision. In *Proceedings of the AAAI Conference on Artificial Intelligence*, volume 36, pp. 10776–10784, 2022.
- Eric Jang, Shixiang Gu, and Ben Poole. Categorical reparameterization with gumbel-softmax. In *International Conference on Learning Representations*, 2017. URL <https://openreview.net/forum?id=rkE3y85ee>.
- Diederik P. Kingma and Jimmy Ba. Adam: A method for stochastic optimization. In Yoshua Bengio and Yann LeCun (eds.), *3rd International Conference on Learning Representations, ICLR 2015, San Diego, CA, USA, May 7-9, 2015, Conference Track Proceedings*, 2015. URL <http://arxiv.org/abs/1412.6980>.
- Aleksandr Laptev, Vladimir Bataev, Igor Gitman, and Boris Ginsburg. Powerful and extensible WFST framework for rnn-transducer losses. In *ICASSP 2023 - 2023 IEEE International Conference on Acoustics, Speech and Signal Processing (ICASSP)*. IEEE, jun 2023. doi: 10.1109/icassp49357.2023.10096679. URL <https://doi.org/10.1109/2Ficassp49357.2023.10096679>.

- Chin-Yew Lin. ROUGE: A package for automatic evaluation of summaries. In *Text Summarization Branches Out*, pp. 74–81, Barcelona, Spain, July 2004. Association for Computational Linguistics. URL <https://aclanthology.org/W04-1013>.
- Liyuan Liu, Haoming Jiang, Pengcheng He, Weizhu Chen, Xiaodong Liu, Jianfeng Gao, and Jiawei Han. On the variance of the adaptive learning rate and beyond. In *International Conference on Learning Representations*, 2020. URL <https://openreview.net/forum?id=rkgz2aEKDr>.
- Yixin Liu, Pengfei Liu, Dragomir Radev, and Graham Neubig. BRIO: Bringing order to abstractive summarization. In *Proceedings of the 60th Annual Meeting of the Association for Computational Linguistics (Volume 1: Long Papers)*, pp. 2890–2903, Dublin, Ireland, May 2022. Association for Computational Linguistics. doi: 10.18653/v1/2022.acl-long.207. URL <https://aclanthology.org/2022.acl-long.207>.
- Vassil Panayotov, Guoguo Chen, Daniel Povey, and Sanjeev Khudanpur. Librispeech: An asr corpus based on public domain audio books. In *2015 IEEE International Conference on Acoustics, Speech and Signal Processing (ICASSP)*, pp. 5206–5210, 2015. doi: 10.1109/ICASSP.2015.7178964.
- Daniel S. Park, William Chan, Yu Zhang, Chung-Cheng Chiu, Barret Zoph, Ekin D. Cubuk, and Quoc V. Le. SpecAugment: A Simple Data Augmentation Method for Automatic Speech Recognition. In *Proc. Interspeech 2019*, pp. 2613–2617, 2019. doi: 10.21437/Interspeech.2019-2680. URL <http://dx.doi.org/10.21437/Interspeech.2019-2680>.
- Rohit Prabhavalkar, Tara N Sainath, Yonghui Wu, Patrick Nguyen, Zhifeng Chen, Chung-Cheng Chiu, and Anjuli Kannan. Minimum word error rate training for attention-based sequence-to-sequence models. In *2018 IEEE International Conference on Acoustics, Speech and Signal Processing (ICASSP)*, pp. 4839–4843. IEEE, 2018.
- Vineel Pratap, Qiantong Xu, Jacob Kahn, Gilad Avidov, Tatiana Likhomanenko, Awni Hannun, Vitaliy Liptchinsky, Gabriel Synnaeve, and Ronan Collobert. Scaling Up Online Speech Recognition Using ConvNets. In *Proc. Interspeech 2020*, pp. 3376–3380, 2020. doi: 10.21437/Interspeech.2020-2840. URL <http://dx.doi.org/10.21437/Interspeech.2020-2840>.
- Alec Radford, Jong Wook Kim, Tao Xu, Greg Brockman, Christine McLeavey, and Ilya Sutskever. Robust speech recognition via large-scale weak supervision, 2022.
- Yusuke Shinohara and Shinji Watanabe. Minimum latency training of sequence transducers for streaming end-to-end speech recognition. In *Proc. Interspeech 2022*, pp. 2098–2102, 2022. doi: 10.21437/Interspeech.2022-10989.
- Xingchen Song, Di Wu, Zhiyong Wu, Binbin Zhang, Yuekai Zhang, Zhendong Peng, Wenpeng Li, Fuping Pan, and Changbao Zhu. Trimtail: Low-latency streaming asr with simple but effective spectrogram-level length penalty. In *ICASSP 2023 - 2023 IEEE International Conference on Acoustics, Speech and Signal Processing (ICASSP)*, pp. 1–5, 2023. doi: 10.1109/ICASSP49357.2023.10097012.
- Jinchuan Tian, Brian Yan, Jianwei Yu, CHAO WENG, Dong Yu, and Shinji Watanabe. BAYES RISK CTC: CONTROLLABLE CTC ALIGNMENT IN SEQUENCE-TO-SEQUENCE TASKS. In *The Eleventh International Conference on Learning Representations*, 2023a. URL <https://openreview.net/forum?id=Bd7GueaTxUz>.
- Zhengkun Tian, Hongyu Xiang, Min Li, Feifei Lin, Ke Ding, and Guanglu Wan. Peak-first ctc: Reducing the peak latency of ctc models by applying peak-first regularization. In *ICASSP 2023 - 2023 IEEE International Conference on Acoustics, Speech and Signal Processing (ICASSP)*, pp. 1–5, 2023b. doi: 10.1109/ICASSP49357.2023.10095377.
- Ashish Vaswani, Noam Shazeer, Niki Parmar, Jakob Uszkoreit, Llion Jones, Aidan N Gomez, Łukasz Kaiser, and Illia Polosukhin. Attention is all you need. In I. Guyon, U. Von Luxburg, S. Bengio, H. Wallach, R. Fergus, S. Vishwanathan, and R. Garnett (eds.), *Advances in Neural Information Processing Systems*, volume 30. Curran Associates, Inc.,

2017. URL https://proceedings.neurips.cc/paper_files/paper/2017/file/3f5ee243547dee91fbd053c1c4a845aa-Paper.pdf.

Changhan Wang, Morgane Riviere, Ann Lee, Anne Wu, Chaitanya Talnikar, Daniel Haziza, Mary Williamson, Juan Pino, and Emmanuel Dupoux. VoxPopuli: A large-scale multilingual speech corpus for representation learning, semi-supervised learning and interpretation. In *Proceedings of the 59th Annual Meeting of the Association for Computational Linguistics and the 11th International Joint Conference on Natural Language Processing (Volume 1: Long Papers)*, pp. 993–1003, Online, August 2021. Association for Computational Linguistics. doi: 10.18653/v1/2021.acl-long.80. URL <https://aclanthology.org/2021.acl-long.80>.

Yongqiang Wang, Abdelrahman Mohamed, Due Le, Chunxi Liu, Alex Xiao, Jay Mahadeokar, Hongzhao Huang, Andros Tjandra, Xiaohui Zhang, Frank Zhang, Christian Fuegen, Geoffrey Zweig, and Michael L. Seltzer. Transformer-based acoustic modeling for hybrid speech recognition. In *ICASSP 2020 - 2020 IEEE International Conference on Acoustics, Speech and Signal Processing (ICASSP)*. IEEE, may 2020. doi: 10.1109/icassp40776.2020.9054345. URL <https://doi.org/10.1109%2Ficassp40776.2020.9054345>.

Wei Yang, Yang Liu, and Chunjing Xiao. Deep metric learning for accurate protein secondary structure prediction. *Knowledge-Based Systems*, 242:108356, 2022. ISSN 0950-7051. doi: <https://doi.org/10.1016/j.knosys.2022.108356>. URL <https://www.sciencedirect.com/science/article/pii/S0950705122001332>.

Zengwei Yao, Wei Kang, Fangjun Kuang, Liyong Guo, Xiaoyu Yang, Yifan Yang, Long Lin, and Daniel Povey. Delay-penalized ctc implemented based on finite state transducer, 2023.

Jiahui Yu, Chung-Cheng Chiu, Bo Li, Shuo-yiin Chang, Tara N. Sainath, Yanzhang He, Arun Narayanan, Wei Han, Anmol Gulati, Yonghui Wu, and Ruoming Pang. Fastemit: Low-latency streaming asr with sequence-level emission regularization. In *ICASSP 2021 - 2021 IEEE International Conference on Acoustics, Speech and Signal Processing (ICASSP)*, pp. 6004–6008, 2021. doi: 10.1109/ICASSP39728.2021.9413803.

Albert Zeyer, Ralf Schlüter, and Hermann Ney. Why does ctc result in peaky behavior?, 2021.