

Sustainable Adaptive Security

Liliana Pasquale*, Kushal Ramkumar*, Wanling Cai†, John McCarthy‡, Gavin Doherty†, Bashar Nuseibeh§

* Lero@University College Dublin

† Lero@Trinity College Dublin

‡ Lero@University College Cork

‡ Lero@University of Limerick

Abstract—With software systems permeating our lives, we are entitled to expect that such systems are secure by design, and that such security endures throughout the use of these systems and their subsequent evolution. Although adaptive security systems have been proposed to continuously protect assets from harm, they can only mitigate threats arising from changes foreseen at design time. In this paper, we propose the notion of *Sustainable Adaptive Security* (SAS) which reflects such enduring protection by augmenting adaptive security systems with the capability of mitigating newly discovered threats. To achieve this objective, a SAS system should be designed by combining automation (e.g., to discover and mitigate security threats) and human intervention (e.g., to resolve uncertainties during threat discovery and mitigation). In this paper, we use a smart home example to showcase how we can engineer the activities of the MAPE (Monitor, Analysis, Planning, and Execution) loop of systems satisfying sustainable adaptive security. We suggest that using anomaly detection together with abductive reasoning can help discover new threats and guide the evolution of security requirements and controls. We also exemplify situations when humans can be involved in the execution of the activities of the MAPE loop and discuss the requirements to engineer human interventions.

I. INTRODUCTION

Security threats are on the rise. Many recent critical cyber security incidents, such as log4j and SolarWinds, arose from newly discovered threats [1]. Therefore, there is a need to build systems that are secure by design, but that can also detect and mitigate newly discovered security threats over extended periods of time. Although adaptive security approaches [2], [3] have been proposed to mitigate evolving security threats, they only address threats arising from changes foreseen at design time. However, unanticipated changes, such as newly discovered assets and vulnerabilities or wrong domain assumptions, can bring new security threats and require security requirements and controls to evolve at runtime.

In this paper, we propose the notion of *Sustainable Adaptive Security* (SAS) which reflects the capability of adaptive security systems to preserve security requirements throughout their use and subsequent evolution. Systems satisfying sustainable adaptive security (hereafter referred to as SAS systems) should be capable of discovering changes that may bring unanticipated security threats and managing the evolution of security requirements and controls to mitigate such threats. Although autonomy is a desired property of SAS systems, human intervention can be beneficial to preserve security requirements in the long run, for example, by monitoring security-relevant data and supporting decision making [4]–[6].

We use an example of a smart home to motivate the need for sustainable security. We explain how we can engineer the activities of the MAPE (Monitor, Analysis, Planning, and Execution) loop [7] of SAS systems. We showcase that combining anomaly detection with abductive reasoning can help discover new security threats and guide the evolution of security requirements and controls to mitigate such threats. We also exemplify how humans can assist the SAS system in executing the activities of the MAPE loop. Using our example, we discuss three requirements (security, trust, and usability) to be considered when engineering human interventions. Finally, we conclude with a discussion of a future research agenda for the research community to develop SAS systems.

II. SMART HOME SECURITY EXAMPLE

Fig. 1 illustrates the plan of the smart home (on the left) and exemplifies some of the unexpected changes that can occur (on the right). The home has a WiFi router and a smart lock which secures the physical space of the home. Devices connected to the WiFi network can potentially control the smart lock [8] and send commands to open and close the door. A security goal [9] that we aim to maintain is the integrity of the smart home. This goal can be achieved by preventing unauthorised access to the smart home. Specifically, the smart lock should only lock or unlock the door when an authorised user (tenant) intends for the action to occur. We focus the scope of our research on a system that is currently deployed. This is because modern systems include components built by different vendors. Discovering threats during development may not be feasible because new threats can emerge depending on how a system is deployed and configured, e.g., depending on the type and location of the devices in the smart home.

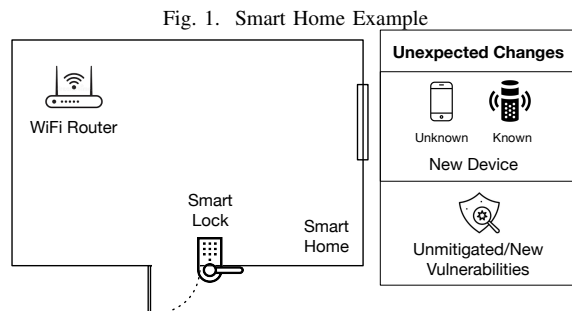

A new digital device can connect to the WiFi network. Such device may be unknown and can control the smart lock letting an outsider inside the house unaccompanied. In such case, a new security control should prevent the new device from controlling the smart lock. The presence of unknown devices connected to the WiFi network can indicate security misconfiguration (e.g., weak passwords, insecure encryption protocols) or new vulnerabilities in the WiFi router. Therefore, any security control initially selected by the system will not preserve security in the long run because it may not address the root cause of the problem.

A new device (e.g., smart speaker) connecting to the WiFi network may, instead, be known and trustworthy and require temporary authorisation to access the smart lock and other appliances in the smart home. However, adding a new device, can also bring new vulnerabilities. For example, a smart speaker may be authorised to control the smart lock, but may be vulnerable to ultrasonic voice command attacks that are inaudible [10]. This not only violates the security requirement from the example, but also puts other devices controllable by the smart speaker at risk.

If new devices connect too frequently to the WiFi network, an adaptive security system can learn that new devices should not be allowed to connect to the WiFi network. The system can also ask the tenant to confirm whether the security control should be enacted. However, an abrupt notification without any explanation of why such security control is necessary can decrease the trust in the system and in the security posture of the smart home. Also, the tenant may not have the expertise to understand whether the suggested security control is effective.

The smart home can also be vulnerable to attacks exploiting *unmitigated or new vulnerabilities*. Some vulnerabilities, although they are known, they are not mitigated due to insufficient security knowledge [11] or delayed updates [12]. For example, an unmitigated vulnerability in the smart lock (e.g., CVE-2022-32509) may enable man in the middle attacks and allow an outsider inside. Other vulnerabilities are new and a fix does not exist for them yet.

III. SUSTAINABLE SECURITY

In the system security community, sustainable security has been defined as the capability of an organisation to continuously secure a multitude of devices, running potentially outdated versions of software, for long periods of time [13]. It has also been considered as the property of a network intrusion detection system to ensure continuous reliable operation [14], or the capability of organisational processes to be more resilient to insider threats [15]. The notion of sustainable security is also related to cyberresilience [16], i.e. "the ability to prepare for and recover quickly from both known and unknown threats". Although cyberresilience metrics [17] have been defined to compare system design and prioritise upgrades and maintenance, previous work has not considered how to engineer systems that can address unknown threats and satisfy evolving security requirements over time, an extension of the concept of sustainability in software engineering [18], [19].

As systems are increasingly socio-technical, our definition of sustainable security considers both a system and a human perspective. We define sustainable security as *the capability of a system to preserve security requirements over sustained periods of time*. To achieve this aim, systems need to continuously identify and mitigate emerging threats by *adapting* their security controls or evolving the requirements specification. When mitigating threats they should identify short-term security controls that stop the malicious action, but also long-term controls that address the root-cause of the threat and prevent the recurrence of the same threat.

From a human perspective, sustainable security should refer to *the design of technology that enables interactions between the system and the humans to achieve cyberresilience*. To the best of our knowledge, the notion of cyberresilience has not been explored in the HCI community. Previous work has studied how technology plays a role in various forms of resilience to disaster and displacement [20]–[22], and also how individuals respond to mandated technology adoption [23]. Humans should complement the system functionality to support selection and execution of effective security controls that preserve security in the long run. Human participation can be sustained by engineering usable interactions that also increase trust in the system and its security posture. Usability can be achieved by avoiding obtrusiveness. Trust can be fostered by enabling humans to understand how the system operates and what is happening at the current moment.

IV. ENGINEERING SAS SYSTEMS

We revisit the activities of the MAPE loop to engineer Sustainable Adaptive Security (SAS) systems, as shown in Fig. 2. To discover new threats the monitoring activity not only should assess satisfaction of requirements and assumptions on the operating environment (domain assumptions) but should also detect unusual behaviours (anomalies), which can provide indicators that security requirements and controls should evolve. We assume that the SAS system can collect data about the user behaviour (e.g., entering, exiting, whether the door is locked or unlocked or whether new devices are present in the network). The analysis activity should diagnose unusual behaviour and assess whether new threats can materialise. The planning activity should identify how security requirements and controls should evolve, if necessary. The execution activity should enact security controls. We assume that the SAS system is separated from the system under protection (smart home), although it can observe/control the devices in the smart home.

Humans can be involved in the execution of the activities of the MAPE loop in capacities other than the traditional user [24], [25] such as security and software engineers. For example, during monitoring a user can provide information about data that cannot be observed by the SAS system (e.g., whether a device connected to the WiFi network is trustworthy). During analysis, information about a discovered anomaly can be provided to software/security engineers to diagnose the anomaly, if it cannot be done automatically. During planning, a user can confirm whether a security control can be enacted

Fig. 2. Sustainable Adaptive Security System

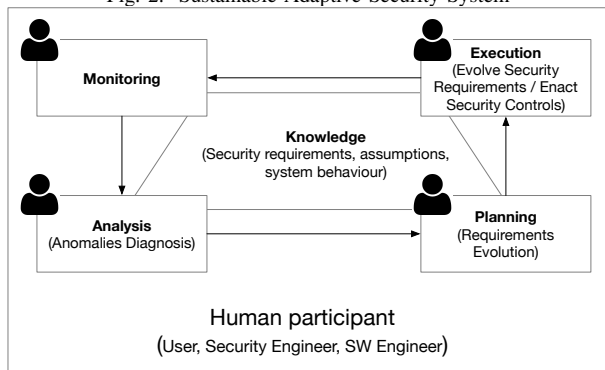

(e.g., forcing closure of the door of the smart home). Finally, humans can support execution of security controls (e.g., the tenant may be asked to return home).

Similarly to previous work on adaptive security [26], we use a goal modeling framework [27] to make security requirements refinements and dependencies on environment conditions explicit. We suggest that a representation of security requirements can help engineer the activities of the MAPE loop of a sustainable adaptive security system. Fig. 3 shows a simplified goal model of the smart home example. The root goal represents the security requirement related to the authorised access to the smart home. This requirement can be achieved by authenticating access to the smart lock and securing access to the WiFi network. Two-Factor authentication is used to access the smart lock. An 8 character password is used for the WiFi network and the length of the password is assumed to be sufficient to protect the network. We assume that a) trusted devices in the WiFi network do not let an outsider in the smart home unaccompanied; b) the smart lock cannot be tampered with; c) an outsider can only enter if the door is unlocked and d) the tenant always locks the door when they exit.

In the rest of this section we showcase how abductive reasoning can be used to diagnose whether an anomaly can lead to the violation of the authorisation requirement for the unexpected changes described in Section II. We encoded the goal model and the system functionalities (e.g., opening/closing door, entering/exiting) using Answer Set Programming and use clingo to perform abductive reasoning¹. As suggested by Alrajeh et al. [28], symbolic learning techniques can use traces of the system behaviour satisfying and violating the authorisation requirement to learn how security requirements and controls should evolve. We also exemplify how humans can participate in the activities of the MAPE loop.

A. New Device Connects to the WiFi Network

The monitoring activity detects that a new device is connected to the WiFi network. However, to diagnose the anomaly the SAS system needs to know whether the device is trustworthy, i.e. known to the tenant. If the device (`d1`) is not

¹For reasons of space, we omit information about the ASP models in this paper and refer the interested reader to <https://tinyurl.com/256tfktc>

trustworthy, the ASP model will be updated accordingly and will generate a trace showcasing how the authorisation requirement can be violated, as shown below.

```
exit(tenant,home,1), close(s1,2),
  open(d1,s1,3), enter(outsider,home,4),
  in(outsider,home,4).
```

After the tenant exits at time 1 and closes the door at time 2, the new device sends a command to the smart lock (`s1`) to open the door and lets an outsider inside.

The SAS system can learn to evolve the specification by, for example, preventing the new device from sending an open command to the smart lock as shown below.

```
X!d1 :- open(X,s1,T), net_device(X), T = 0..4.
```

In this case, human participation can be sought to understand whether the security control selected by the SAS system should be enacted. To foster trust, observability and transparency principles should be satisfied [29]. In other words, the SAS system should indicate that a network device that is not trustworthy was detected (observability) and that the suggested security control is necessary to prevent the new device from letting an offender inside unaccompanied (transparency). Alternatively, it may be desirable to evolve security controls differently, for example by removing the new device from the WiFi network. Although alternative security controls can be discovered automatically by the system, the tenant may not have the expertise to select one appropriately. Thus, intervention of the system/security engineer may be necessary to perform this task. If an engineer is required to modify security controls, the SAS system should also satisfy the intelligibility principle [29] by communicating in what ways security controls can be modified without introducing additional vulnerabilities.

However, the security controls identified above may not be sustainable if the new device is trustworthy. For example, the tenant may want to use a new smart speaker to send commands to the smart lock to open and close the door. Thus, the SAS system should ask the tenant whether the device is trustworthy, to avoid selecting ineffective security controls. To increase the likelihood that the tenant completes the task successfully, the SAS system should satisfy the feedforward principle [29] by providing the tenant with information about the detected device (e.g., type of device). Similarly to the previous example, to satisfy observability, the SAS system should indicate that a new device was detected. To satisfy transparency the SAS system should indicate that, if the device is trustworthy, access to the network and the home appliances will be granted.

Now, let us imagine that new devices keep connecting to the WiFi network frequently. To avoid sending frequent notifications to the tenant, the SAS system may learn that new devices should not be allowed in the WiFi network by default or can ask the tenant whether, from now on, they may want to prevent any new device from connecting to the network. In this case, the SAS system should satisfy observability by indicating that new devices are connected to the network too frequently. It should also satisfy transparency by explaining

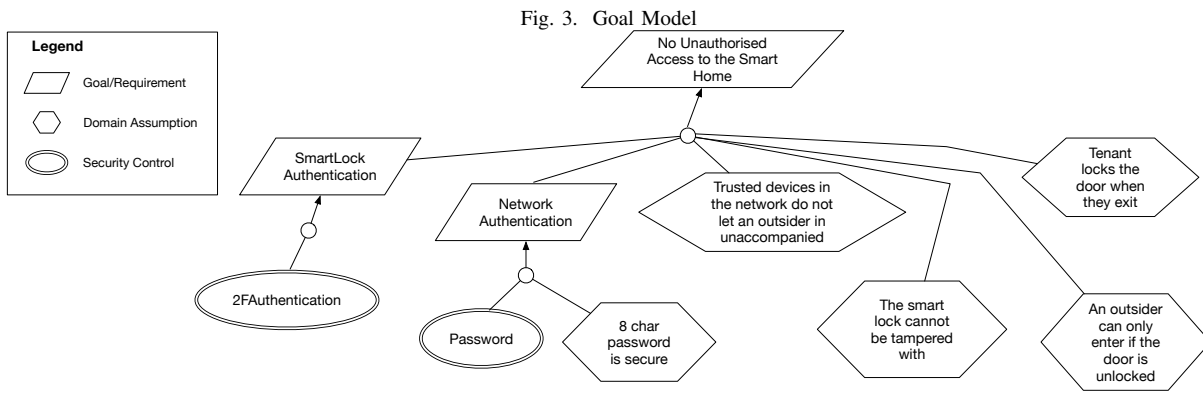

that forbidding access to new devices will require the tenant to manually grant access to the network when a new device will connect to the WiFi network in the future.

However, these security controls may not be sustainable, because they may not address the root cause of the problem, which can be that the network authentication is not effective. Thus, the SAS can use the structure of the goal model to identify which security control is responsible to regulate access to the network and, for example, evolve the domain assumption related to the password strength by increasing the minimum number of characters for a password to be considered strong. Changing the domain assumption will force the system to learn that a longer password needs to be enforced. In this case, human input should be sought to identify the minimum number of characters that a password should have. Since the tenant may not have the expertise to advise on the password length, a security/software engineer may need to be involved to perform this task.

B. New Vulnerabilities

If the monitoring activity measures the latency of requests and responses to and from appliances in the smart home it can discover unusual latencies that can indicate the presence of a man-in-the-middle attack. These types of attacks can be due to authentication vulnerabilities. For example, the Nuki Smart Lock was found to lack SSL/TLS certificate validation, allowing an attacker to perform a man-in-the-middle attack and intercept network traffic (CVE-2022-32509).

Such vulnerability cannot be diagnosed automatically and the SAS system needs to identify a security control that could prevent an attack from happening. In such a case, the domain assumption on the trusted devices in the network may no longer be valid. Removing that domain assumption from the ASP model makes the system identify a violating trace where a trusted device in the network could still let an outsider inside unaccompanied. This trace can be used to learn a security control that blocks any incoming traffic to the smart lock. This security control is not sustainable in the long run because it does not address the root cause of the problem. Intervention of a security/software engineer needs to be sought to confirm the presence of a vulnerability. If information about the vulnerability has already been disclosed (e.g., a CVE entry

is available) a patch needs to be identified and applied to the vulnerable device. Also, the requirement specification needs to be updated with an indication of the vulnerability and the fix. Alternatively, advice needs to be sought from the software/security engineer on how the disclosure of a new vulnerability and how to fix it.

V. RELATED WORK

Previous work on security requirements engineering [30]–[36] has focused on modelling and reasoning about security concerns to assess risks, identify security controls and estimate the impact of design choices on the protection of the critical assets of the system. These approaches typically require a complete model of the system and have not been designed to support requirements evolution. Other approaches [37], [38] trigger requirements evolution according to pre-defined rules, when security properties are violated. More recently, Drodzov et al. [39] have used symbolic-based learning to learn security policies from historical data produced by anomaly detectors. The authors adopt a domain-specific function to guide the learning process towards the best policies for anomaly detection. Although promising, this work has not been adopted to evolve security requirements at runtime.

In the adaptive security community, previous work has suggested to evolve the representation of threats based on the automated derivation of changing architectural system models from runtime and operational system artifacts [40]. Calo et al. [41] propose an approach to generate access control policies dynamically when the environment changes, assuming that a set of constraints associated with the resources to be accessed are satisfied. To the best of our knowledge, there is no systematic technique to detect and prevent/mitigate evolving threats brought by unexpected changes, such as vulnerabilities and ineffective security controls at runtime.

Explanations have been used to involve humans in the execution of the activities of an adaptive system [42], [43]. In the security domain, Nhlabatsi et al. [44] help users understand security decisions by establishing traceability relationships between requirements and security concerns (e.g., threats, attacks and vulnerabilities). More recently, Adepu et al. [45] characterise explanations in terms of content, effect, and cost (i.e. human effort necessary to understand the explanation).

The authors use probabilistic reasoning to determine when an explanation should be used to improve overall system utility. However, they do not configure the content of an explanation depending on the input required from the human participant. Models of human participants have been used to decide whether humans should be involved during the planning [46] or execution [47] activity of adaptation. Li et al. [48] propose a framework to reason about the usage of preparatory notifications in adaptive systems. Preparatory notifications can focus the attention of human participants on the task to be performed and help them understand its context before task execution. However, previous work has provided limited guidance on how human intervention should be requested and provided. Gil et al. [29] proposes a conceptual framework to characterise the cooperation between humans and autonomous cyber-physical systems and provide techniques for applying the framework to design human integration. However, this framework has not been applied in the context of an adaptive security system.

VI. RESEARCH AGENDA

A. Engineering Autonomy in SAS Systems

During monitoring SAS systems need to identify events that can be observed by the devices that can be controlled in the environment and those for which human intervention is necessary. For example, a combination of device fingerprinting and human intervention [49] can be used to identify new devices connected to the WiFi network.

During analysis, to detect the root cause of an anomaly, it will be necessary to identify parts of the requirements model that require revision. The devices and domain assumptions that are affected by the anomaly can be used to identify the parts of the model that require revision automatically. In our example, frequent connectivity of new devices to the WiFi network required us to revise the security controls protecting the network. If not possible, human intervention should be sought to select the parts of the model that need revision. There can also be situations when anomalies cannot be diagnosed, for example, when we have unanticipated or new vulnerabilities.

We will attempt to detect unanticipated vulnerabilities by referencing the behavioural pattern of the anomaly against an up-to-date knowledge database of attacks created from vulnerability disclosures and vulnerability databases. To detect and mitigate new vulnerabilities, it will be necessary to identify what type of information can be disclosed to software and security engineers to obtain meaningful input.

During planning there can be several ways in which security controls can evolve. This will depend on the examples that are used to perform the learning activity. One challenge to be addressed is the generation of examples and the identification of heuristics that can drive the learning towards the selection of security controls that are effective in the long run, while avoiding human intervention.

In this paper we assumed that the requirements, functionalities, and domain assumptions of the system to be protected are specified in advance. However, this may not always be possible, for example, when new components are added to the

system at runtime. Thus, it will be interesting to understand how the system functionalities, domain assumptions and security controls can be learnt from scratch. For example, transfer learning can be used to learn the behaviour of new components from similar ones. Online learning can be used to learn how heterogeneous components can interact when placed together. Then, neural symbolic learning [50] can be used to learn a model of the system behaviour. Finally symbolic learning can be used to learn the security controls that satisfy the system security requirements. Human input will be necessary to identify the security requirements and the security controls available, and to revise the model learnt from scratch.

B. Engineering Human Interventions

Engineering human interventions requires identifying the tasks to be performed by human participants. In this paper, we initially identified some of them (e.g., provisioning of monitoring information, hypothesis on the root cause of an anomaly, and selection/modification of security controls). However, it will be necessary to elicit such tasks in a more systematic way using a larger set of scenarios from different application domains (e.g., cloud computing). Once tasks are determined, it will be desirable to identify the roles and expertise of humans that can perform these tasks.

Moreover, SAS system should enable effective and usable interaction with humans. To achieve this aim, it will be necessary to consider the following aspects: (1) "who" – who will be involved in the task, (2) "when" – human or the system initiate the actions, and the level of automation or human control for performing the task [51] (e.g., some tasks can require selection but others can require modification of security controls); (3) "how" – human and the system can communicate with each others (4) what information should be exchanged between the human and the system. To foster trust the information exchanged should satisfy some of the properties of human-system integration [29].

Evaluating sustainable adaptive security systems also brings new research challenges. From a system perspective, properties such as timeliness and longevity are very relevant. Timeliness refers to how fast such systems can prevent threats from happening compared to traditional adaptive security systems. Longevity can refer to how long security requirements are satisfied. To evaluate SAS systems from a human perspective, we can consider assessing the successful completion of the task by the participants, but also evaluate sustainable security from an "experiential perspective" by assessing the perceived security level of the system experienced by human participants [52].

REFERENCES

- [1] Checkpoint. (2021) Check Point 2022 Security Report. [Online]. Available: <https://tinyurl.com/3vu8paav>
- [2] E. Yuan, N. Esfahani, and S. Malek, "A Systematic Survey of Self-Protecting Software Systems," *ACM Trans. Auton. Adapt. Syst.*, vol. 8, 2014.
- [3] G. Tziakouris, R. Bahsoon, and M. A. Babar, "A Survey on Self-Adaptive Security for Large-Scale Open Environments," *ACM Comput. Surv.*, vol. 51, 2018.

- [4] N. Görnitz, M. Kloft, K. Rieck, and U. Brefeld, "Active learning for network intrusion detection," in *Proc. of the 2nd ACM Workshop on Security and Artificial Intelligence*, 2009, p. 47–54.
- [5] K. Yang, J. Ren, Y. Zhu, and W. Zhang, "Active learning for wireless iot intrusion detection," *IEEE Wireless Comm.*, vol. 25, no. 6, pp. 19–25, 2018.
- [6] F. Franssen, R. Wolthuis, and N. el Ouajdi. (2019, January) Security at Machine Speed. [Online]. Available: <https://tinyurl.com/yc478pnz>
- [7] E. Lara, L. Aguilar, M. A. Sanchez, and J. A. García, "Adaptive Security Based on MAPE-K: A Survey," *Applied Decision-Making: Applications in Computer Sciences and Engineering*, pp. 157–183, 2019.
- [8] S. Veijalainen and T. Noreng Karlsson, "Evaluating the Security of a Smart Door Lock System," 2021.
- [9] C. P. Pfleeger, *Security in Computing*. Pearson Education India, 2009.
- [10] J. Mao, S. Zhu, X. Dai, Q. Lin, and J. Liu, "Watchdog: Detecting Ultrasonic-Based Inaudible Voice Attacks to Smart Home Systems," *IEEE Internet of Things Journal*, vol. 7, pp. 8025–8035, 2020.
- [11] E. Zeng, S. Mare, and F. Roesner, "End user security and privacy concerns with smart homes," in *Thirteenth Symp. on Usable Privacy and Security (SOUPS 2017)*, 2017, pp. 65–80.
- [12] F. Li and V. Paxson, "A large-scale empirical study of security patches," in *Proc. of the 2017 ACM SIGSAC Conf. on Computer and Comm. Security*, 2017, p. 2201–2215.
- [13] R. Anderson, "Making security sustainable," *Comm. of the ACM*, vol. 61, pp. 24–26, 2018.
- [14] G. Koutsandria, R. Gentz, M. Jamei, A. Scaglione, S. Peisert, and C. McParland, "A real-time testbed environment for cyber-physical security on the power grid," in *Proc of the First ACM Workshop on Cyber-Physical Systems-Security and/or PrivaCy*, 2015, p. 67–78.
- [15] M. Hanse, "Insider Threats" and "Supporting Sustainable Security" – Adding the Dimension of Privacy and Data Protection, Organizational Processes for Supporting Sustainable Security (Dagstuhl Seminar 12501)," *Dagstuhl Reports*, vol. 2, pp. 2192–5283, 2013.
- [16] Z. A. Collier, D. DiMase, S. Walters, M. M. Tehranipoor, J. H. Lambert, and I. Linkov, "Cybersecurity Standards: Managing Risk and Creating Resilience," *Computer*, vol. 47, no. 9, pp. 70–76, 2014.
- [17] I. Linkov, D. A. Eisenberg, K. Plourde, T. P. Seager, J. Allen, and A. Kott, "Resilience Metrics for Cyber Systems," *Environment Systems and Decisions*, vol. 33, pp. 471–476, 2013.
- [18] B. Penzenstadler, V. Bauer, C. Calero, and X. Franch, "Sustainability in software engineering: a systematic literature review," in *16th Int. Conf. on Evaluation & Assessment in Software Engineering (EASE 2012)*, 2012, p. 32 – 41.
- [19] C. Becker, R. Chitchyan, L. Duboc, S. Easterbrook, B. Penzenstadler, N. Seyff, and C. C. Venters, "Sustainability design and software: The karlskrona manifesto," in *Proc of the 37th Int. Conf. on Software Engineering*, 2015, pp. 467–476.
- [20] S. I. Ahmed, N. J. Mim, and S. J. Jackson, "Residual Mobilities: Infrastructural Displacement and Post-Colonial Computing in Bangladesh," in *Proc. of the 33rd Annual ACM Conf. on Human Factors in Computing Systems*, 2015, pp. 437–446.
- [21] G. Mark and B. Semaan, "Resilience in Collaboration: Technology as a Resource for New Patterns of Action," in *Proc. of the 2008 ACM Conf. on Computer Supported Cooperative work*, 2008, pp. 137–146.
- [22] G. J. Mark, B. Al-Ani, and B. Semaan, "Resilience Through Technology Adoption: Merging the Old and the New in Iraq," in *Proc. of the SIGCHI Conf. on human factors in Computing systems*, 2009, pp. 689–698.
- [23] N. Karusala, I. Holeman, and R. Anderson, "Engaging Identity, Assets, and Constraints in Designing for Resilience," *Proceedings of the ACM on Human-Computer Interaction*, vol. 3, no. CSCW, pp. 1–23, 2019.
- [24] E. P. Baumer, "Usees," in *Proc. of the 33rd Annual ACM Conf. on Human Factors in Computing Systems*, 2015, pp. 3295–3298.
- [25] E. P. Baumer and J. R. Brubaker, "Post-Userism," in *Proc. of the CHI Conf. on Human Factors in Computing Systems*, 2017, pp. 6291–6303.
- [26] M. Salehie, L. Pasquale, I. Omoronyia, R. Ali, and B. Nuseibeh, "Requirements-Driven Adaptive Security: Protecting Variable Assets at Runtime," in *2012 20th IEEE international requirements engineering conference (RE)*. IEEE, 2012, pp. 111–120.
- [27] A. Van Lamsweerde, *Requirements Engineering: From System Goals to UML Models to Software*. John Wiley & Sons, 2009, vol. 10.
- [28] D. Alrajeh, A. Cailliau, and A. van Lamsweerde, "Adapting requirements models to varying environments," in *2020 IEEE/ACM 42nd Int. Conf. on Software Engineering (ICSE)*, 2020, pp. 50–61.
- [29] M. Gil, M. Albert, J. Fons, and V. Pelechano, "Designing Human-in-the-Loop Autonomous Cyber-Physical Systems," *International journal of human-computer studies*, vol. 130, pp. 21–39, 2019.
- [30] L. Liu, E. Yu, and J. Mylopoulos, "Security and Privacy Requirements Analysis within a Social Setting," in *Proc. of 11th IEEE Int. Requirements Engineering Conference, 2003.*, 2003, pp. 151–161.
- [31] A. Van Lamsweerde, "Elaborating Security Requirements by Construction of Intentional Anti-Models," in *Proceedings. 26th International Conference on Software Engineering*. IEEE, 2004, pp. 148–157.
- [32] P. Giorgini, F. Massacci, J. Mylopoulos, and N. Zannone, "Modeling Security Requirements through Ownership, Permission and Delegation," in *Proc. of the 13th Int. Conf. on Req. Eng.*, 2005, pp. 167–176.
- [33] C. Haley, R. Laney, J. Moffett, and B. Nuseibeh, "Security Requirements Engineering: A Framework for Representation and Analysis," *IEEE Trans on Software Engineering*, vol. 34, pp. 133–153, 2008.
- [34] Y. Yu, V. N. Franqueira, T. T. Tun, R. J. Wieringa, and B. Nuseibeh, "Automated Analysis of Security Requirements through Risk-Based Argumentation," *Journal of Sys. and Softw.*, vol. 106, pp. 102–116, 2015.
- [35] L. Pasquale, P. Spoletini, M. Salehie, L. Cavallaro, and B. Nuseibeh, "Automating Trade-off Analysis of Security Requirements," *Requirements Engineering*, vol. 21, pp. 481–504, 2016.
- [36] S. Türpe, "The Trouble with Security Requirements," in *Proc. of the 25th Int. Requirement Engineering Conf.*, 2017, pp. 122–133.
- [37] G. Bergmann, F. Massacci, F. Paci, T. T. Tun, D. Varró, and Y. Yu, "A Tool for Managing Evolving Security Requirements," in *In Proc. of the 23rd International Conference on Advanced Information Systems Engineering Forum*. Springer, 2011, pp. 49–56.
- [38] J. Bürger, J. Jürjens, and S. Wenzel, "Restoring security of evolving software models using graph transformation," *International Journal on Software Tools for Technology Transfer*, vol. 17, pp. 267–289, 2015.
- [39] A. Drozdov, M. Law, J. Lobo, A. Russo, and M. W. Don, "Online Symbolic Learning of Policies for Explainable Security," in *Proc. of the 3rd Int. Conf. on Trust, Privacy and Security in Intelligent Systems and Applications*, 2021, pp. 269–278.
- [40] D. van Landuyt, L. Pasquale, L. Sion, and W. Joosen, "Threat Modeling at Run Time: The Case for Reflective and Adaptive Threat Management (NIER track)," in *2021 Int. Symp. on Software Engineering for Adaptive and Self-Managing Systems (SEAMS)*, 2021, pp. 203–209.
- [41] S. Calo, D. Verma, S. Chakraborty, E. Bertino, E. Lupu, and G. Circione, "Self-Generation of Access Control Policies," in *Proceedings of the 23rd ACM on Symposium on Access Control Models and Technologies*, 2018, pp. 39–47.
- [42] K. Welsh, N. Bencomo, P. Sawyer, and J. Whittle, "Self-Explanation in Adaptive Systems based on Runtime Goal-Based Models," in *Trans. on Computational Collective Intelligence*. Springer, 2014, pp. 122–145.
- [43] N. Li, S. Adepu, E. Kang, and D. Garlan, "Explanations for human-on-the-loop: A probabilistic model checking approach," in *Proceedings of the IEEE/ACM 15th International Symposium on Software Engineering for Adaptive and Self-Managing Systems*, 2020, pp. 181–187.
- [44] A. Nhlabatsi, T. Tun, N. Khan, Y. Yu, A. Bandara, K. M. Khan, and B. Nuseibeh, "Why Can't I Do That?": Tracing Adaptive Security Decisions," *EAI Endorsed Trans. on Self-Adaptive Systems*, vol. 1, no. 1, 2015.
- [45] S. Adepu, N. Li, E. Kang, and D. Garlan, "Modeling and Analysis of Explanation for Secure Industrial Control Systems," *ACM Trans. Auton. Adapt. Syst.*, vol. 17, no. 3–4, 2022.
- [46] E. Lloyd, S. Huang, and E. Tognoli, "Improving Human-in-the-Loop Adaptive Systems using Brain-Computer Interaction," in *Proc. of the 12th Int. Symp. on Software Engineering for Adaptive and Self-Managing Systems*, 2017, pp. 163–174.
- [47] J. Cámara, G. Moreno, and D. Garlan, "Reasoning About Human Participation in Self-Adaptive Systems," in *2015 IEEE/ACM 10th International Symposium on Software Engineering for Adaptive and Self-Managing Systems*. IEEE, 2015, pp. 146–156.
- [48] N. Li, J. Cámara, D. Garlan, B. Schmerl, and Z. Jin, "Hey! Preparing Humans to Do Tasks in Self-Adaptive Systems," in *Proc. of the 16th Int. Symp. on Software Engineering for Adaptive and Self-Managing Systems*, 2021, pp. 48–58.
- [49] T. O'Connor, R. Mohamed, M. Miettinen, W. Enck, B. Reaves, and A.-R. Sadeghi, "Homesnitch: Behavior transparency and control for smart home iot devices," in *Proc. of the 12th Conf. on Security and Privacy in Wireless and Mobile Networks*, 2019, p. 128–138.
- [50] A. d. Garcez, S. Bader, H. Bowman, L. C. Lamb, L. de Penning, B. Illumino, H. Poon, and C. G. Zaverucha, "Neural-Symbolic Learning

and Reasoning: A Survey and Interpretation,” *Neuro-Symbolic Artificial Intelligence: The State of the Art*, vol. 342, no. 1, 2022.

- [51] M. Muller and J. Weisz, “Extending a Human-AI Collaboration Framework with Dynamism and Sociality,” in *2022 Symposium on Human-Computer Interaction for Work*, 2022, pp. 1–12.
- [52] J. M. Haney, S. M. Furman, and Y. Acar, “Smart Home Security and Privacy Mitigations: Consumer Perceptions, Practices, and Challenges,” in *Proc. of the 2nd Int. Conf. on HCI for Cybersecurity, Privacy and Trust*, 2020, pp. 393–411.