

# **Ensoule:** A framework for the creation of self organizing intelligent ultra low power systems (SOULS) through evolutionary enerstatic networks.

Ty Roachford

Florida Atlantic University

Machine Perception and Cognitive Robotics (MPCR) Lab

[Ty@TyfoodsForThought.com](mailto:Ty@TyfoodsForThought.com)

## **Abstract**

Ensoule is a framework proposed for the purpose of creating technologies that create more technologies through the combined use of networks, and nests, of energy homeostatic (enerstatic) loops and open-ended evolutionary techniques. Generative technologies developed by such an approach serve as both simple, yet insightful models of thermodynamically driven complex systems and as powerful sources of novel technologies. “Self Organizing intelligent Ultra Low power Systems” (SOULS) is a term that well describes the technologies produced by such a generative technology, as well as the generative technology itself. The term is meant to capture the abstract nature of such technologies as being independent of the substrate in which they are embedded. In other words, SOULS can be biological, artificial or hybrid in form.

## **Motivation and Outline**

The contents of this paper are written with the intention of connecting topics that are believed to help provide insight into fundamental questions about life and intelligence as well as assist in motivating the particular approach that this paper takes to creating generative technologies. It is written at a high level and as such the precise technical details of certain topics are left out. This has been done for a number of reasons. The first is that this paper is meant to be rather concise. Many of the precise details of each topic are not necessary to understand the connection between topics. Secondly, it is meant to allow for those without specialized backgrounds to more easily follow the thread of discussion. This should make the paper as accessible as possible. Readers who wish for a deeper understanding can refer to the various references provided in this text.

The main questions that have motivated an evolutionary enerstatic network approach to building generative technologies are the following:

- How do components of naturally evolved systems come together to work towards a common interest? In other words, how does self-organization work?
- How do “embedded agents”, that is, agents that are made out of the same “stuff” as the environment they are in, make decisions under logical uncertainty (i.e. with limited spatiotemporal access to the environment and limited processing power)?
- How can one capture the complexity of nature in computer simulations without randomly searching the space of possible models, or solely using mathematical methods to create, tune and run highly parameterized biologically accurate models?

The major topics that this paper then synthesizes and proposes to explore are:

- Energy homeostatic (enerstatic) loops as powerful models
- The Free Energy Principle (FEP) as an informative description of such models

- Open ended evolution through energetically closed systems of enerstatic loops
- Assembly theory as an informative description of such closed systems.

Specifically, the paper is organized into eight sections as follows:

1. The **“Teleology, TAME and SOULS”** section, details why it is helpful to talk about systems as having “goals” as motivated by the free energy principle, cybernetics and the Technological Approach to Mind Everywhere (TAME) framework. In that same context, the term “SOULS” is then explained as being an ideal description of such substrate-independent phenomena.
2. The **“Open-Ended Evolution and Assembly Theory”** section describes what “Open-Ended Evolution” actually is, as it relates to one of the goals of the field of evolutionary programming. It further discusses open-ended evolution’s relationship to assembly theory and posits a “zoomed out” look at assembly systems in general.
3. The **”IOS Illusions: Motivating Modeling With Enerstatic Networks”** section motivates enerstatic loops, networks and nests as an ideal abstraction for modeling SOULS as opposed to an “Input Output” system based approach.
4. The **“Enerstatic Networks”** section discusses how an enerstatic loop works with a simple code explanation, and also outlines how it can be specialized to model neural networks in particular whose generalization served as the birth of abstract enerstatic networks.
5. The **“Evolving Enerstatic Networks”** section is the main contribution of this paper. It describes how open-ended evolution might be achieved through the use of energetically closed systems harboring enerstatic loops which naturally interact to form enerstatic networks and nests. As in the case of the “Enerstatic Networks” section, as much detail as possible is given without prescribing particular implementation details.
6. **“Thermodynamic Computing & Enerstatic Networks”** explains what thermodynamic computing is, and posits that enerstatic loops, networks and nests may serve as an extensible general model system for their development.
7. **“Taming SOULS”** explains enerstatic networks as enacting cooperative and competitive dynamics whose consequences drive behavior and discusses approaches towards understanding and controlling such dynamics. In particular, the “Test for Controlled Variable” is discussed along with general outlines for a “Test for Variable Controllability” and a “Test for Control Switch”.
8. **“Discussion: Research Directions, Speculations and Philosophy”** suggests possible research directions, speculates on the potential benefits of such research, and finally discusses the philosophical implications of deep scientific knowledge.

All sections are laid out in a way that follows a more conversational and “story-like” format, rather than “just” an academic style paper. Papers with more technical details and specific implementation methodologies along with empirical data from actual experiments are underway. It was deemed important to get these connections out there before the results from such experiments were completed in order to make the ideas behind such work readily accessible to both the scientific community, and the enthusiastic layman. The following is a small, but exciting step into the future of technology, technology made with SOULS.

## Teleology, TAME and SOULS

Any “thing” that exists for longer than 1 Planck length of time must be “doing something” that allows it to persist its existence. This is the most general form of the “Free Energy Principle” (FEP), which is a theory that was initially proposed by Karl Friston to explain the brain’s behavior before being extended to living and non-living “things”. In mathematical form, we say that a “thing” is a “dynamical system”, specifically a dynamical system in a “non-equilibrium steady state” (NESS), and that what the system is “doing” allows it to keep itself in that state [12]. The “something” that the system is “doing” can generally be called “self-evidencing”, a term that Carl Gustav Hempel introduced with respect to explanations for events. This is just what it sounds like, the verb form of something being “self-evident”. An explanation is self-evidencing if the event which it explains provides key evidence for the explanation [54, 22]. It turns out that a big part of the explanation for the persistent existence of every “thing” that we can observe can

be understood in terms of what it is doing. Simply put, if a “thing” wasn't engaging in this self-evidencing process to at least some degree, then it wouldn't persist.

A related argument in the same vein, is that for something to exist – despite not persisting its existence – it must necessarily have causal power. In other words, it must be exerting some sort of effect on its environment. This has been called the “Eleatic Principle”, which was first described in Plato's book “Sophist” [40]. FEP simply extends this to suggest that when looking at anything which is able to **persist** its existence, then one would find, upon measurement, that the causal power it is exerting must, on average, be self-evidencing.

**Dynamics of the fundamental particles create a structure. This structure's effect on the environment constitutes the ensemble's “causal power”, which biases the environment towards rebuilding it at every timestep. This causal power constitutes the structure's “actions” (i.e. what it “does” in order to exist).**



- Simplified illustration of “Self-Evidencing Causal Power”. An environmental fluctuation results in “too many” particles inside the boundary, resulting in one of the bound particles being ejected.
- A key phrase in the description is “biases the environment”. It's not necessarily the case that the structure is capable of guaranteeing its own self-creation. It may be that the structure only increases the probability that the environment will re-create the structure for some duration of time.

By establishing a formal connection between the particular dynamics of a “thing” and variational inference, the FEP allows us to speak of “things” created via some self-organizing process, teleologically [15]. That is, to speak about a “thing” with respect to its “goal”. The term “goal” can be understood in a strictly cybernetic sense. In a cybernetic system, the system's goal is to regulate the value of a certain variable just as a thermostat regulates the temperature. The system's regulatory behavior is considered to be “goal-directed”. Since the most primary variable that a “thing” must be regulating in order for it to persist its existence is its own particular dynamics, we can indeed speak of its behavior as being goal-directed. Thus, the FEP suggests that the primary goal of every “thing” is to self-evidence, regulate its particular dynamics, or most specifically, minimize its variational free energy through the process of variational inference. A detailed explanation on the mathematics behind how the aforementioned formal connection is made is outside the scope of this paper. Readers can refer to [15] for more information.

What is important about the construction of this formal connection between the particular dynamics of a “thing” and variational inference is that it serves as a guiding principle for better understanding the behavior of any “thing” whose intelligence and cognition is related to how well it can perform such self-evidencing variational inference. In other words, all “things” exhibit some degree of intelligence and cognition. Indeed, even the fundamental units, or particles, in any theory of everything must necessarily have this “self-evidencing through inference” characteristic in order to persist its existence through time and thus has in the most minimal sense, a degree of intelligence and cognition.

There are a few terms here that deserve further discussion, namely, definitions of intelligence and cognition, as well as arguments for why this paper prefers teleology over teleonomy. The definition of terms intelligence and cognition have been fraught with arguments in a way that is similar to what is meant by “consciousness” has. As such this paper provides no strict definition of the two that everyone has agreed upon. Instead, it takes an operational stance by defining them with respect to the mathematics of variational inference underwriting the FEP. When describing any “thing” the language of FEP speaks of its “beliefs”, which essentially constitute knowledge that the “thing” has about the causes of its “sensory perceptions”. It further suggests that any

“thing” must be “doing something”, that is, taking “actions”, upon its external environment, which are based on its “beliefs”. In this paper, the transformation of “sensory perceptions” and “beliefs” into “actions” upon an external environment, which are on average in the service of self-evidencing, is cognition. Cognition can then be measured via the degree to which that “thing” can “sense”, “believe” and “act”. In other words, cognition can be measured via the answer to questions such as: “What does it sense and to what level of detail? What seem to be its beliefs?”, and “What are the actions available to it?” respectively. Intelligence, then, is a quality of this “sense”, “believe”, “act” cycle. In particular, intelligence is the adaptive capacity of a “thing” to accomplish its “goal” of existence. In other words, if we see something that exists, then the closer that it can get to non-existence (“death”) in some particular way (i.e. the more “stressed” it can get) and pull itself back into a “healthy” state, the more intelligent we say that thing is. The ability of a “thing” to pull itself back into a “healthy state” from a “stressed state” necessarily entails the ability of that “thing” to update its “beliefs” and therefore change its actions. This is because it must necessarily do different things than that which resulted in that “stressed state”. Thus, when that “thing” becomes better by some measure at pulling itself back into a “healthy state” from a specific type of “stressed state”, then we will say that it has learned. The various ways that a “thing” can be “stressed” indicate the various ways in which a system has the opportunity to demonstrate intelligence, thus intelligence is a multi-dimensional characteristic of cognition.

Teleonomy is a term that was developed to distinguish between “things” that have “real goals” (teleological systems), like humans, and “things” that only look “as if” they have “real goals” (telenomic systems), like robots, or bacteria. This paper argues that this distinction is unnecessary based on the formal connection that the FEP made between a “thing’s” particular dynamics and inference, the application of the cybernetic sense of a “goal”, and on the following argument which focuses on the shared intrinsic characteristic of all things, existence.

#### **Argument for fundamental teleology:**

1. A “goal” is the desired result of a thing’s behavior.
2. Identification of something’s goal given its behavior is an unsolved, and in some cases potentially intractable, problem [5, 2, 24].
3. However, any “thing” that exists, must be exhibiting behavior which allows it to exist, in order to exist.
4. Thus, existence is a result of any “thing” that exists behavior.
5. The question is then: Does this “thing” “intend” to exist, is that its “desired” goal? – We want to know whether this is the case or not, because we can only measure intelligence by observing behavior with respect to some goal. There are only two possible answers:
  - a. Existence is its goal, in which case, observing its behavior allows us to measure its intelligence.
  - b. Existence is NOT its goal, in which case, observing its behavior allows us to measure its **incompetence**

While both answers to the “intentional existence” question posed in point 5 are equivalent in what they allow for with respect to measurement of a “thing’s” behavior, the interpretation that each allows is different. Only the first answer's interpretation properly aligns with what we commonly understand as “intelligence”.

Readers may have noticed that there is a potential problem with this definition of intelligence with respect to a “thing’s” existential goal. If you are observing some “thing” and it dies, does that mean it was necessarily incompetent in some way? Would that further suggest that “things” which die voluntarily are incompetent? For example, what about the case of a war hero who sacrifices himself to save his team? The answer is that one must broaden the lens through which they are observing. The definition of intelligence in this paper requires that one properly identify the “thing” of study, and in the case of a sacrificial war hero, such a sacrificial event cannot be properly understood outside of the context that it is embedded in. Instead of looking at the war hero as an individual “thing”, this paper suggests that, upon observation of such a sacrificial event, they must now be looked at in context of the team, or collective, they are embedded in, whose higher scale intelligence now becomes the “thing” of study. In this context the war hero would not necessarily be considered “incompetent” because they are operating as part of a larger organization, which may be the appropriate “thing” of study. An analogy can also be drawn between the protective skin cells of an organism, and the organism itself. The sacrificial behavior of skin doesn’t justify a judgment of incompetence.

This sort of existentially-based multi-scale analysis of intelligence has consequences for what it means to be a particular individual “thing”, or “self”.

You have a “self” when the components that make up any “thing” operate towards the same macro-level goal states [10, 49, 1]. Most importantly, these components come to operate together only through their natural physical behavior abiding by the path of least action [32]. An important part of establishing a coherent “self” is through the sharing of stress. The sharing of stress enforces cooperation over competition by making defection an impossibility. For example, in a situation where components are isolated from each other in terms of stress, it is possible for component A to stress component B without increasing its own stress levels. However, if stress is shared between components via physical forces, or molecules, then component A stressing any other component would increase that component’s own stress levels. The larger the degree to which stress is shared between components the more of an impossibility that defection becomes and the more coherent the “self”. This binding of individual “selves” through stress can lead towards more resources, and therefore computational power, being utilized towards the same aim [30, 29, 11]. This might be summed up in the following phrase: “When what stresses you, stresses me, we are a self”.

As we can see from our previous discussion, the concepts of “intelligence”, “cognition”, “goals”, “stress”, and “self” are all invariant across all “things” at every spatial scale from fundamental particles to humans, and beyond. Additionally, these concepts are completely naturalistic and operational in their definitions. In other words, not only are they useful concepts through which one can make measurements and perform engineering tasks, but they also do not require anything that’s not included in the laws of physics at the most fundamental level. It is in this sense that the evolution of the universe since its inception has been one in which these fundamental properties have been scaled up through the combination of various “things”.

The process through which more complex “things” arise can be thought of as a generalized form of evolution in which all “things”, rather than just “living organisms” specifically, are the object of natural selection. In this generalized evolution, we speak about the stability of “things” rather than the fitness of “things”. Rather than saying “Only the fittest survive”, we say “Only the most stable persist” [53]. In other words, “things” that are more stable “out compete” “things” that are less stable. This process of generalized evolution is well described by assembly theory in what is then called an “assembly process” which will be discussed in more detail in the “Open-Ended Evolution, Assembly Theory and Modeling” section [36].

Given that: (1) components of “things” come to operate together through their own behavior (2) such “things” as well as their components can be described as having “intelligence” (3) that the behavior of all things are only following the path of least action, it would seem that any “thing” that is assembled during an assembly process can be best described as **self organizing** in that its structure arises due to local interactions between its otherwise independent parts, **intelligent** with respect to its adaptive capacity to meet its existential goal, and **ultra low power** with respect to how much energy it requires to meet that same existential goal. This is why such structures are best described as Self Organizing intelligent Ultra Low power Systems, or SOULS.

This paper focuses on what we, as humans, can do to assist in the combination of “things” such that what we build results in practical technologies that can be used for both science and engineering. As previously seen, the invariant multi-scale characteristics intrinsic to all “things” break down discrete categories by placing “things” on a spectrum in which the experimenter, or engineer must ask “How much” and “What kind” of property does this “thing” that they are studying, or engineering with, have [30, 49, 29]? As such, the terminology being used to refer to the “thing” in question best reflects the goals of the observer rather than the intrinsic properties of the “thing” itself. “Things” can be called “structures”, “materials”, or “components”, in the case of engineering, “chemicals”, “organisms”, “life”, in the case of biology, or, as we will see in the case of Ensoul, enerstatic loops, networks and nests, which are abstractions of SOULS at different scales.

Technological Approach to Mind Everywhere (TAME) is a framework being developed by Dr. Michael Levin which aims to provide an experimentally-grounded framework for understanding diverse bodies and minds, or SOULS. The goal of the framework is to use such invariants as a mode of thinking about how we can both create, and engineer with, structures that have various levels of intelligence and cognition. An important concept in TAME is the “axis of persuadability”. Levin states: “Persuadability refers to the type of conceptual and practical tools that are optimal to rationally modify a given system’s behavior.” Some SOULS are more persuadable than others, and their persuadability is, in part, a function of what Levin describes as a SOULS’ “cognitive light cone” [30, 49, 29]. The cognitive light cone represents the spatiotemporal degree to which a SOULS’ intelligence, or problem solving ability, can take into account. For example, simple unicellular

organisms might “care” only about things like local sugar gradients, and events that occur on the order of milliseconds to perhaps seconds. In contrast, humans can care about what’s going to happen to the universe (huge space), in a few billion years (long time). Thus, the cognitive light cone of a human is much larger than that of a simple unicellular organism.

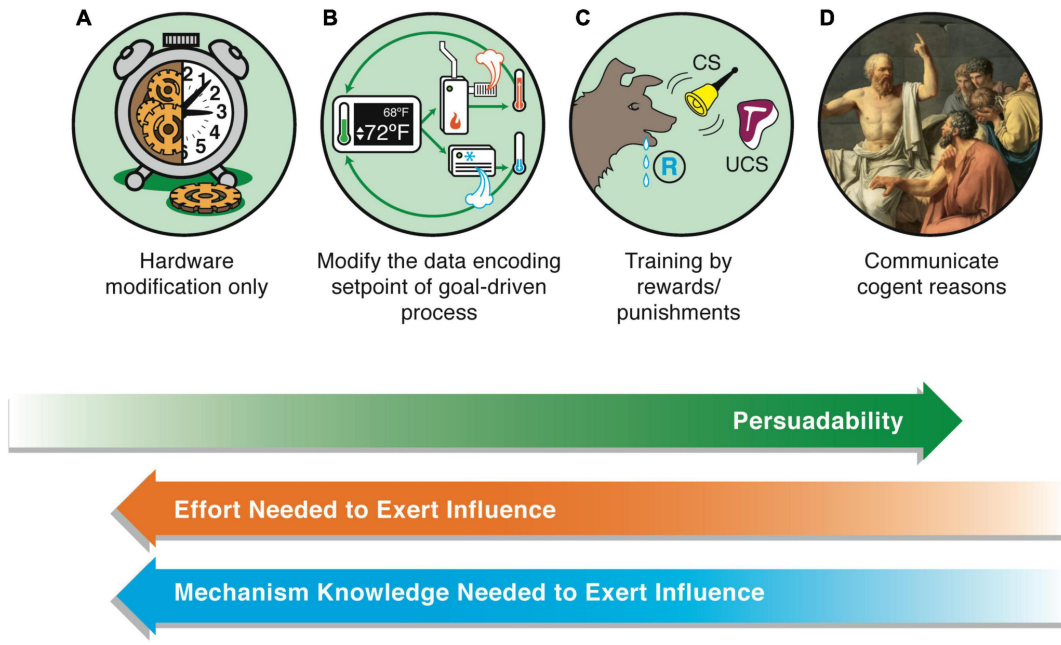

- "Figure adapted from Levin (2022), published in *Frontiers in Systems Neuroscience*, under the Creative Commons Attribution License (CC BY). Source: <https://www.frontiersin.org/articles/10.3389/fnsys.2022.768201/full>"

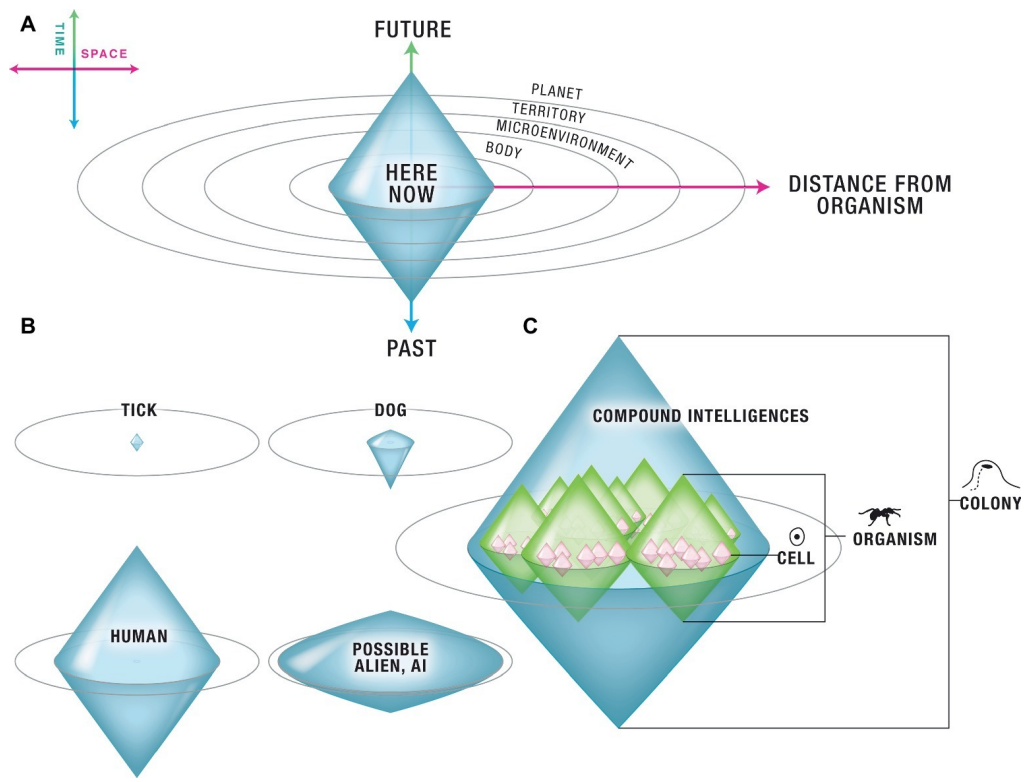

- "Figure adapted from Levin (2019), published in *Frontiers in Psychology*, under the Creative Commons Attribution License (CC BY). Source: <https://www.frontiersin.org/articles/10.3389/fpsyg.2019.02688/full>"

For practical purposes, it is helpful to define the axis of persuadability on a per-goal basis. Some SOULS are better than others depending on the goal independent of their persuadability. For example, if one’s goal is for the SOULS to bake cookies, a typical computer would need to be broken down into its constituent pieces and reconfigured perhaps into a small cookie making robot. This would be low on the axis of persuadability as it requires brute force micromanagement. However, a working chef would only need to be told what to make and perhaps convinced with some money. In this way, the axis of persuadability with respect to some goal is anti-parallel with the amount of information required to meet that goal. In other words, the amount of energy that must necessarily be expended by the TAMEer in order to have the SOULS meet some goal decreases as the SOULS’ position on the axis of persuadability moves to the right.



- Degree of persuadability vs the amount of energy, in the form of knowledge/effort, needed to get the SOULS to align with your goal.
- "Figure adapted from Levin (2022), published in *Frontiers in Systems Neuroscience*, under the Creative Commons Attribution License (CC BY). Source: <https://www.frontiersin.org/articles/10.3389/fnsys.2022.768201/full>"

It is important to recognize that the axis of persuadability is a spectrum. We covered the extreme left, micromanagement, and the extreme right, communication of cogent reasons, of the axis, but there are SOULS in the middle as well. Two examples illustrated in the axis of persuadability graphic are of a thermostat, and a dog. If one’s goal is to change the temperature of some room they are in, then the thermostat is a good bet, and you don’t need to micromanage all of its components in order to do so, you only need to change the set-point. Similarly, if one’s goal is to have a dog bring you a beer from the fridge, micromanaging all its muscles, or trying to control its neurons with a brain computer interface, is probably not the best way to do it. Instead, one can train the dog with treats (rewards). Intelligence is truly in the eye of the beholder here. One must recognize how one’s goals align with the goal of the SOULS that they are interacting with. The closer this alignment, the easier it is to “convince” the SOULS to do what you’d like. More of TAME and other tools for identifying the higher “non-existential” goals of a particular SOULS such that it can be modified and worked with are discussed in the “Taming SOULS” section. We first turn to other concepts related to the development of enerstatic networks as a tool for SOULS creation.

## Open-Ended Evolution and Assembly Theory

Despite the title, the field of evolutionary programming has not yet been able to capture the true open-ended evolution that we observe when we look around the universe. Dr. Kenneth Stanley suggests that the reason is because most evolutionary algorithms are still focused on optimization rather than divergence, and that the problem with optimization is that the most ambitious goals are deceptive with respect to their path to get there [28]. In other words, if your goal is to create something like Artificial General Intelligence (AGI), then the path there is not at all straight-forward. In actuality, there will be many deceptive looking sub-goals that appear to take you closer to your goal, but actually take you farther from it. We see hints of this when training a neural network to perform some task. The neural network can move into a local minima with the “belief” that it’s going in the right direction, but of course, this is actually taking it farther away from the global minima. A great practical example of deception is the example of training a bipedal robot to walk. You can either train it via an objective optimization approach where the goal is to get closer and closer to walking, or you can do this with a divergent explorative approach. Dr. Stanley employed both methods and found that the biped “trained” via divergent exploration actually ended up walking farther than the biped that was optimized towards walking specifically [28]. A more straight-forward example is that of training a

neural network to solve a maze. If you simply optimize for minimizing the distance between the agent and goal, then the following maze constitutes a deceptive example:

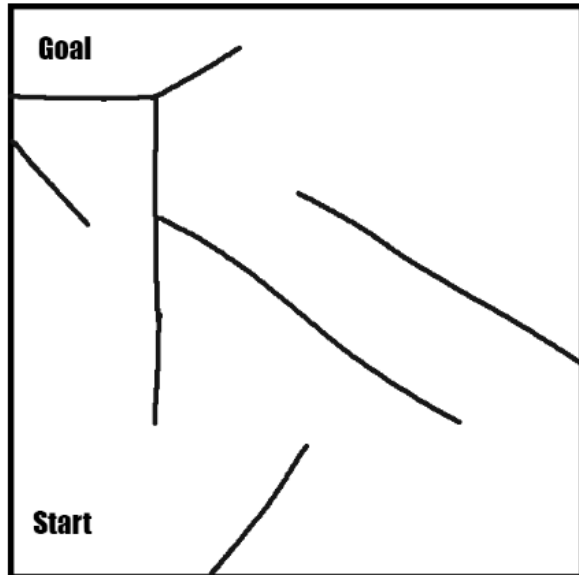

Most of technology has been focused on building machines, or programs, that have particular desired outputs. That is to say, creation of technology has mostly been focused on convergence, rather than divergence. It is this focus on convergence that makes most of technology today “evidence of life” rather than “life” itself. In assembly theory, “evidence of life” refers to structures with an “assembly index” that is higher than a certain threshold. The assembly index is an intrinsic measure of a structure’s complexity [35, 48, 37]. The idea is that high complexity structures have a dramatically smaller chance of being created through random unbiased processes, than through biased processes and thus constitute evidence of some stable constructor. That stable constructor would be considered “evidence of life” and indeed a living structure, or alternatively, a SOULS lying relatively far to the right on the cognitive continuum. The more complex the structure the SOULS is capable of constructing, the more “alive” that SOULS could be said to be. Thus, placing the notion of “alive” on a continuum.

Zooming out, in the context of assembly theory, life itself could be described as the process by which evidence of life, at potentially varying levels of complexity, is generated. In some sense then, our universe is “alive”. Since assembly theory is a physical theory, we can think about other possible universes that may be more or less “alive” than our universe. One could say that the level of “aliveness”, “interestingness”, or “intelligence” of a universe would depend on that universe’s trajectory through “assembly space”. Specifically, the most alive, interesting and intelligent universe would be one whose trajectory, on average, best maximizes the number of unique objects at each possible level of complexity. Interestingly, as a consequence of the FEPs description of the informational symmetry of physical interactions, the environment (i.e. the universe) of any structure must itself be considered an agent (which we will call “U”). Furthermore, as U gains copies of the various structures within it, it is better able to predict the behavior of those structures, and therefore it is better able to minimize its variational free energy (VFE) [13]. If one does indeed grant that intelligence is the capacity of an agent to minimize its VFE, thereby persisting its existence, then the most intelligent universe is one in which the number of copies of each existing unique object is maximized. A more rigorous treatment of measuring aforementioned qualities in assembly systems is outside the scope of this paper.



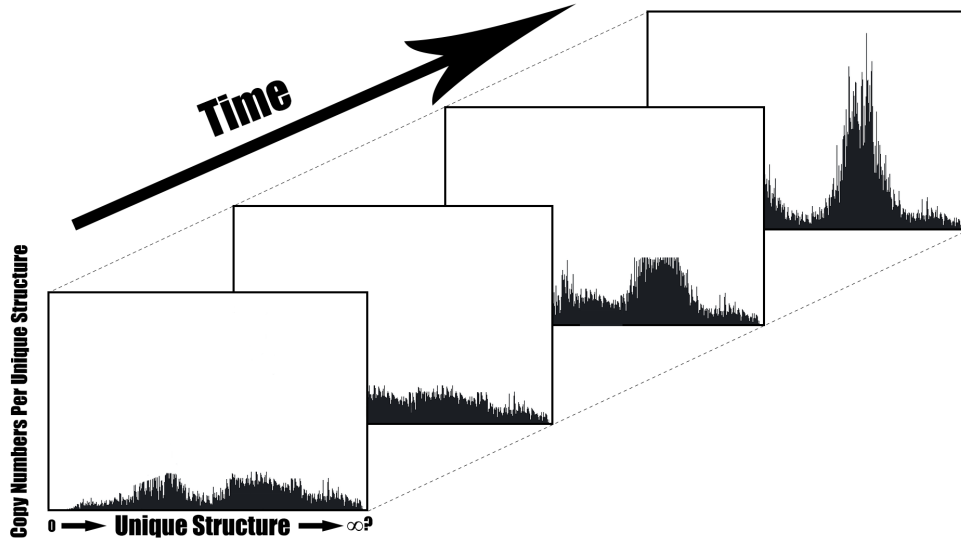

- Demonstrating what the trajectory of an intelligent universe through assembly space might look like. On the x-axis, we have indexes associated with each unique structure. On the y-axis, we have copy numbers associated with each unique structure I.E. how many of that structure is currently present. Each frame represents a different point in time. Each structure-index pair is ordered such that structures towards the right have a greater complexity than structures on the left. This forms a sort of “wave” where structures bootstrap the creation of more complex structures, which additionally represents resource constraints. In other words, under resource constraints, more complex structures preclude the existence of a high number of less complex structures (hence the wave). However, without resource constraints, this wave could in principle propagate forever; Hence the infinity symbol-question mark pair on the bottom right side of the graph. It should further be noted that such infinite propagation would not necessitate a decrease in less complex structures thus increasing perhaps, the “interestingness” and “aliveness” of the system; Interestingness being the diversity and amount of existing structures in general, and aliveness being the diversity and number of living structures, or stable constructors, specifically.

Life itself is thus the process through which SOULS assemble and recombine to create more SOULS of varying complexity (evidence of life that might itself be living). The suggestion here is that we should focus more on how to create technologies that create more technology. In other words, how to create intelligent, open-ended, evolutionary, life processes. This will help us avoid deceptive sub-goals, discover new technologies, and through the study of structures created by such a process, learn more about existing structures, or SOULS.

An interesting point to note here is that an assembly system itself exhibits **self-organization** with respect to consequences of its internal dynamics, **intelligence** with respect to its ability to create and sustain high complexity objects and **ultra low power** in that the “running” of its dynamics (i.e. execution of causal power by its components) require a total of 0 energy [52]. Thus, an assembly system itself can be considered a Self Organizing intelligent Ultra Low Power System, or SOULS.

The requirements for open-ended evolution have been strongly hinted at through biological experimentation and observation [49, 28], and are well described phenomenologically by assembly theory [48]. Evolution doesn’t just employ random mutation, but biased mutation through mechanisms including, but not limited to, enhanced epigenetic capacity, transposition, horizontal gene transfer, and hybridization. Such mechanisms allow organisms produced by evolution to essentially participate in their own evolution through increasingly intelligent mutation operations. This reciprocal biased process is well described by assembly theory.

According to assembly theory, there is information to be gained about a so-called “Assembly Space” by considering the discovery process of assembling novel objects, i.e. the rate at which new objects are discovered ( $k_d$ ) over some time (discover time scale -  $t_d$ ), and the rate of production of a specific object ( $k_p$ ) over some time (production time scale -  $t_p$ ). When the ratio  $k_d/k_p$  is much greater than one, this results in an explosion of unique objects with a low number of copies (low copy number), whereas when  $k_d/k_p$  is much higher than

one, we observe a high abundance of some common objects with high copy number. Either extreme leads to the absence of trajectories that grow more complex objects [48]. It can be demonstrated that the appearance of open-ended evolution in a physical system can be detected by a transition from  $k_p < k_d$  to  $k_d < k_p$ , in other words from no-bias towards what gets created next, to increasingly more bias towards what gets created next.

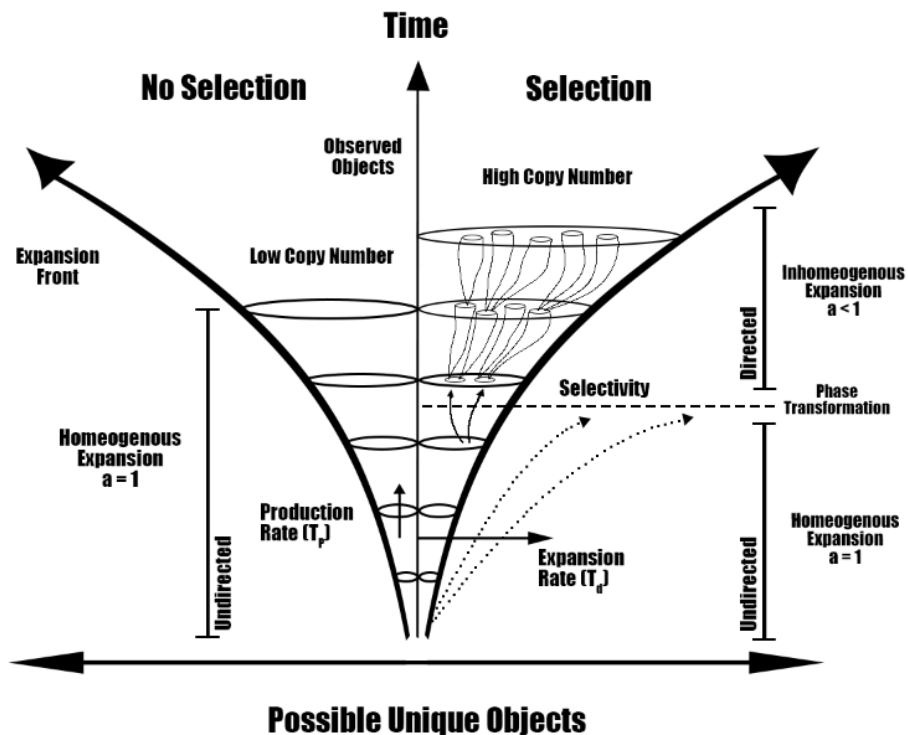

- Graphic demonstrating the transition from unbiased to biased complexity growth that occurs under selection. Figure has been recreated from “Assembly Theory Explains and Quantifies the Emergence of Selection and Evolution”, Source: <https://arxiv.org/ftp/arxiv/papers/2206/2206.02279.pdf> [48]

Essentially, assembly theory asserts that open-ended evolution algorithms follow the format: unbiased exploration to generate unique low-level building blocks which potentially limit the possibility of other low-level building blocks, followed by the combination of those low-level building blocks into “higher level building blocks”, some of which are capable of sustaining themselves across time through their intrinsic causal dynamics. The two questions that this raises are:

1. What are those low level-building blocks?
2. What is responsible for the combination, and selection, of those building blocks into higher level building blocks?

A helpful analogy is to see low-level building blocks as analogous to primitives in a programming language, and to see the entity responsible for combination, and selection, of those building blocks as analogous to software engineers constrained by the syntax, or rules, of the programming language. Software engineers combine these primitives into ever more complicated functions, which are then selected based on their usefulness and used to make ever more complicated pieces of software. Importantly, the programming language being used evolves and diversifies as do the ideas and models through which the software engineers operate. In actuality, this “analogy” is rather just a subset of a larger assembly process that is the evolution of the universe. The focus of this paper is how we can model an assembly process that captures the evolution of the universe “as it could be” using enerstatic loops. But first, we start by motivating why such loops are an ideal candidate for utilization as our low-level building blocks, explain how they work and show an example use case.

## IOS Illusions: Motivating Modeling With Enerstatic Loops

A consequence of the fact that all “things” that exist must be “doing something” in order to exist (I.E. self-evidencing) is that most “things” are not best described as “Input/Output Systems (IOS)” like most typical computers are. Instead, they are best described as SOULS that are regulating their own particular dynamics and in doing so, exert causal power on the environment which appears to be its output in response to some input.

The difference between IOS and SOULS is best illustrated by how each system solves the problems that are presented to them. IOS solve their problems using analytical solutions whereas SOULS solve their problems using non-analytical solutions. Analytical solutions to any given problem constitute modeling that problem explicitly where each “significant” part of the problem has a corresponding part in the model. In this case, the “thing” in question has an explicit model of the problem to be solved. Non-analytical solutions constitute lawful correspondence between a “thing” and its problem such that the natural dynamics of the parts that make up that “thing” solve the problem in question without explicit representation of that problem. In this case, the “thing” \*is\* a model of the problem to be solved. These two problem solving methods have also been referred to as “weak anticipation”, and “strong anticipation”, respectively [51].

A great example of these two very different problem solving methods is their application on the “outfielder problem”, which asks: “How do outfielders catch a fly ball?”

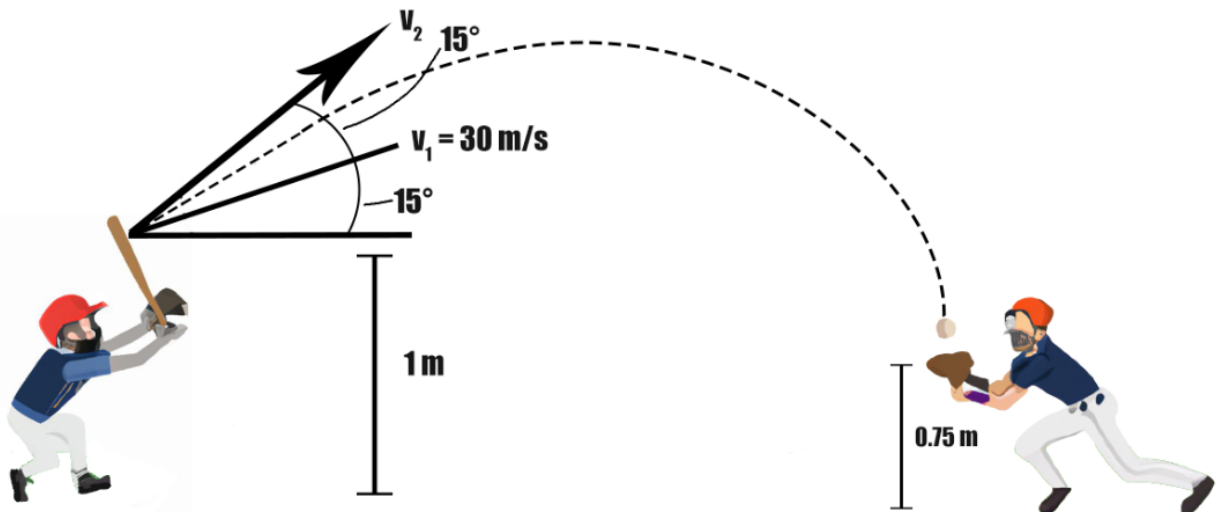

- Illustration of the “Outfielder problem” using an “analytical” solution where one measures the initial conditions of the baseball and calculates its trajectory using equations for projectile motion.

An analytical solution to this problem might constitute the creation of a mathematical model using representative equations. For example, a “thing” could estimate the force and angle at which the ball was hit by the baseball player, and plug those values into equations that represent projectile motion. In this scenario, the “thing” must represent each input variable for the aforementioned equation, as well as the equation itself, with corresponding physical parts. The dynamics of these parts would constitute the calculation of the output which would then have to be used to drive behavior.

A non-analytical approach to the outfielder problem would be to choose some particular aspect of the projectile motion of the baseball and control that variable such that its measured value remains fixed in such a way that leads to one’s desired result. For example, a “thing” could look at the ball flying through the air and attempt to keep the speed of the ball constant in their visual field such that the ball does not appear to speed up or slow down. The idea is that if the ball is accelerating, then it will land behind the “thing”, and if the ball is decelerating then it will land in front of the thing. In this scenario, the “thing” doesn’t require explicit representations; the “thing” only needs to be able to measure changes in speed, and use such changes as feedback for driving behaviors that result in decreased measured change. This proposed solution is called the “Optical Acceleration Cancellation” approach and was first put forward by Seville Chapman [7].

The distinction between an analytical and non-analytical approach is crucial when it comes to understanding

and modeling the “thing” in question. It shifts the focus from “What algorithms is this thing implementing?” to “What variables is this thing controlling?”. Indeed, treating a SOULS as if it is an IOS is a categorical error that can lead to frustration because it can lead one to believe that the behavior of the “thing” is highly variable either due to noise present in its input, or intrinsic non-determinism [32]. The benefits that natural systems receive for engaging in non-analytical methods over analytical methods are clear. Non-analytical methods are simpler, faster, more adaptive and less power hungry while still benefiting from much of the power that prediction has to offer [51]. They accomplish this by avoiding explicit representation of parts of the problem being solved and by avoiding using energy to calculate, and re-calculate, speculative analytical solutions. This suggests that SOULS, rather than IOS, are likely to be the more prevalent solution in nature [43].

Indeed, although IOS do exist in both nature [7] and technology, the parts that make up those IOS consist of a collection of SOULS whose “highly variable behavior” are squelched as much as possible so that they can in effect behave as an IOS. In computer engineering, this “highly variable behavior” goes under the name of “noise”, and comes in many different flavors such as thermal noise, flicker noise, shot noise and quantum noise. Combating such noise is an important part of building fast, reliable computers and thus techniques such as filtering, shielding, grounding, the addition of noise margins, error-correcting codes and clock synchronization are all used towards that end. Indeed, combatting noise due to thermal fluctuations is so important that it has been cited as the leading candidate for the ceasing of the exponentially accelerating rate of technological progress known as Moore’s law [26, 23].

This paper suggests that “highly variable behavior”, or “noise”, in a “thing”, whether that “thing” is a biological organism, or a circuit in a computer, is the observed result of a categorical error. In other words, it is the result of viewing a “thing” as an IOS, when it is better viewed as a SOULS. In this sense, IOS are illusions that are approximated to arbitrary degrees of reliability by SOULS in the same way that the “actual value” of some irrational number like  $\pi$  can only be approximated to arbitrary degrees of accuracy. This has been referred to as the “behavioral illusion” under “Perceptual Control Theory” (PCT) [44, 34, 33]. Does this mean that we should abandon the idea of an IOS-based approach in favor of a SOULS-based approach? This paper suggests otherwise. Instead, just as we appreciate the idea that concepts like “intelligence”, “cognition”, “goals”, “stress”, “self” and “life” lie on a continuum, so should we appreciate the spectrum between idealized SOULS and idealized IOS. We can refer to the degree to which something modifies its own input simply as “feedback”, with zero feedback representing an idealized IOS.

Here, “idealized SOULS” refers to a SOULS that perfectly regulates the variable it is controlling, such that the controlled variable simply cannot be perturbed because any possible perturbation has already been “predicted”. This is akin to mathematical models of anticipatory synchronization in which systems A and B are perfectly coupled such that A always predicts B no matter its behavior [51]. “Idealized IOS” refers to an IOS that is completely deterministic and perfectly reliable. The reference to “idealized” is an acknowledgement that there does seem to be noise in most systems whether they are IOS, or SOULS. For example, in the middle of this spectrum, we might imagine an odd thermostat. This thermostat controls the temperature of the space it is embedded in 50% of the time, while the other 50% of the time it forwards its computations to some other system that does who knows what.

This perspective suggests that when it comes to trying to understand any “thing”, we should first assess whether that “thing” is very much like a reliable IOS, or more like a SOULS. As with assessing the level of any “thing’s” intelligence, the scale of analysis at which this assessment is made, in addition to the careful partitioning of our observed sensory data into “things”, is critical to a proper understanding. A too detailed look at an IOS, no matter how reliable it is, will reveal SOULS-like behavior, in other words, one would observe a collection of “things” that are regulating their own dynamics – A failure of appropriate choice of scale. Similarly, paying attention only to particular pieces of a SOULS can result in the conclusion of simply a collection of noisy IOS – A failure of appropriate partitioning.

Given that SOULS, and not IOS, seem to capture things at the most fundamental level, and that IOS can be approximated arbitrarily well by a collection of SOULS, this paper suggests the usage of a simple abstraction of SOULS in order to model any “thing”. This simple abstraction is an energy homeostatic loop, or in other words, a cybernetic control system that is chiefly concerned with managing its own “energy level”. The big questions that explorations with this abstraction hopes to provide insight to are things like:

1. If everything is made up of one “thing” (energy), how and why do we come to observe distinct things?

2. How might a differing method of the partitioning of energy into “things” be helpful?
3. How do collections of energy homeostatic, or enerstatic loops, come to regulate variables at higher scales (i.e. measurable variables at larger spatial scales like the speed of a ball)?
4. To what degree is it possible to control and get along with such collectives?

## Enerstatic Loops, Networks and Nests.

The Ensoul approach is agnostic as to what form an enerstatic loop can take. The key is only to create a negative feedback system, or control system, that regulates its own “energy level” in such a way that exerts causal power on its environment. In other words, to create an enerstatic loop. The energy level is a partial representation of the state of the enerstatic loop, while the causal power is a representation of the particular energy exchange between the enerstatic loop and its environment, thus making such a loop a “thermodynamically open system”. We are not concerned with how enerstatic loops come to be, instead we make the observation that “nature builds where energy flows” and build our models accordingly. It is critical to not mistake the following specific example implementations as the final, and only way, of creating enerstatic loops. One can think of these only as thought experiments within the Ensoul framework that happen to be implementable as code on a computer.

An enerstatic loop can connect to other enerstatic loops via energy exchange which together constitute an enerstatic network. Those same networks, or singular loops, can be present inside of larger enerstatic loops, which constitute enerstatic nests. This captures the multi-scale fractal nature of reality, however, it can make the terminology confusing. Given such a multi-scale approach, we distinguish between the “main” enerstatic loop that is the subject of study/modeling, and the “lower level enerstatic loops” that are nested inside of our main loop, by calling such nested loops “structures”. We model with enerstatic loops, networks and nests using the following guidelines:

1. There is a flow of energy into the system that depends on the action of that system.
2. This energy flow results in the establishment of an energy distribution, where energy is higher and lower in different parts of the system in the form of other enerstatic loops, or “structures”. The establishment of this energy distribution represents the system starting out “alive” I.E. in a non-equilibrium steady state.
3. This energy flow results in the aforementioned energy distribution being modified in some way.
4. There is an inevitable loss of energy as the system generates entropy via exertion of causal power.
5. Structures can only be assembled in areas where energy density is high enough to support such assembly.
6. There are rules defining the space of possible structures available for assembly by our enerstatic loop
  - a. A structure is minimally composed of the following elements
    - i. Cost of assembling structure
    - ii. Cost of disassembling structure
    - iii. Position in space
    - iv. Causal Power of the structure
    - v. Cost of the causal power
      1. Causal power always has a cost and “eats up” energy based on the particular effect that the power has at every time step. Not meeting this energy requirement would result in the non-existence of the structure.

Causal power of a structure consists of the following properties:

- b.
  - i. Sensed Input Properties, this is the set of properties that the structure is “aware” of.
  - ii. Affected Output Properties, this is the set of properties that the structure exerts its causal power on. i.e.. properties that are modified by the structure.

- iii. The effective radius, this is the distance at which properties can be sensed, or affected. This may be different for different properties.

When the system is unable to perform actions that allow for an appropriate flow of energy, the system “dies” i.e. falls into equilibrium.

To get a better idea of how to meet all these guidelines, we will quickly fashion together a minimal enerstatic network consisting of minimal enerstatic loops. To begin with, we acknowledge that an enerstatic loop is a control system, which formally consists of four components: (1) A “control center”, which defines the ideal “set point”, or state, of the system (2) A “physiological variable”, or a “sense” of the variable to be regulated (3) “Sensors”, which are used to gain information about the environment (4) “Effectors”, which are mechanisms used to modify the environment. This takes us well on our way to meeting all our previous guidelines. The following is working javascript code for the most minimal enerstatic loop, where we can see all of these features reflected:

```
const timeStepToStopPerturbations = 500;
const energySetPoint = 0;
const energyConstant = 100;
const perturbationStrength = 10;
const nTrails = 1000;
const effectorCost = 10;
const effectorCount = 1;
function enerstaticNode(){
  //Energy set point defined by the "control center"
  let energyLevel = energySetPoint;
  for (let timeStep=0; timeStep<nTrails; timeStep+=1){
    console.log(`Energy at Trial ${timeStep}:`, energyLevel);
    if( isDivisibleBy(timeStep) && timeStep < timeStepToStopPerturbations ){
      //Perturbation "sensed" via causal effect on "action decision"
      energyLevel-=perturbationStrength;
    }
    //Action decision rules I.E.
    //Whether the "effector" exhibits causal power or not
    if(energyLevel > energySetPoint){
      energyLevel-=energyConstant * effectorCount; //"Effector" action
      continue;
    }
    if(energyLevel < energySetPoint){
      energyLevel+=energyConstant * effectorCount; //"Effector" action
      continue;
    }
  }
  if(energyLevel === 0) console.log("Enerstasis Reached"); //Lived
  else console.log("Failed to reach enerstasis."); //Died
}
enerstaticNode();
```

In our case, the “Set point”, or “Control Center” is 0 and represents energy, in other words, the energy level that the enerstatic loop wants to maintain is 0. Therefore, this value is both the setpoint and the physiological variable to be regulated. Our minimal enerstatic loop only has one sensor, and that is a sense of its physiological variable, its energy. It is implicitly a sense in that when the energy level changes, this has an effect on whether the “effectors” it has exhibit their causal power or not. The loop has a “sense” of its environment through the effect that the environment has on its physiological environment, and reacts as to remove the effects of this energetic perturbation.

# Minimal Enerstatic Node

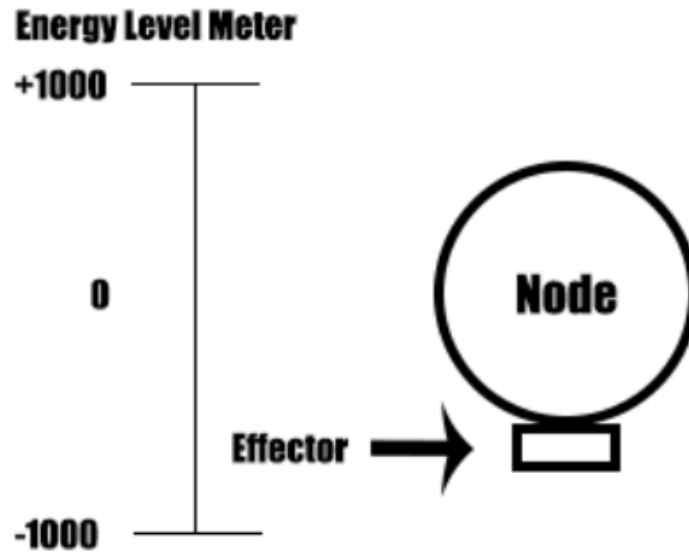

Our minimal enerstatic loop is lacking quite a few things to make it interesting/extensible, specifically:

1. There is only one loop in the environment
2. Its structure (i.e. its single effector) is fixed in that it cannot be added/removed.
3. The single effector doesn't have an assembly/disassembly and causal power cost
4. Death of the loop isn't explicitly defined
5. Cannot take active actions, and doesn't have any sort of learning capacity
6. The flow of energy into the system doesn't depend on the actions of that system
7. There no loss of energy as the loop operates

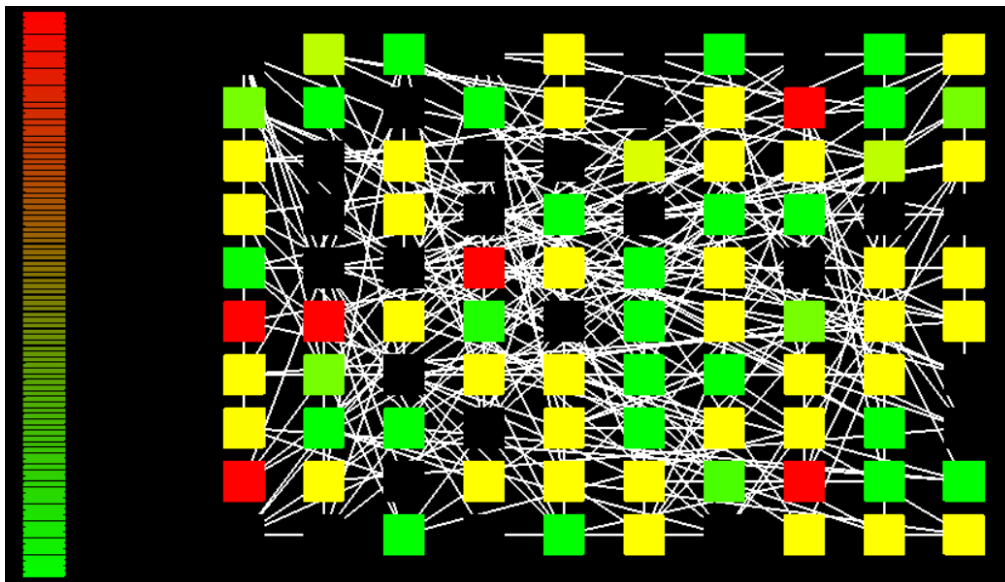

- Example of a Minimal Enerstatic Network (MEN): Loop health is represented according to the color of the loop. Towards red means that a loop is close to its fatal energy threshold, whether that's too much, or too little energy. The opacity/transparency of each loop moves towards clear when the loop is towards its negative energy threshold. Dead loops end up invisible, but their associated energy channels

do not. Each loop has 3 instances of a structure called an “Energy Channel”, whose causal powers shifts energy between origin and target loops based on the origin's energy level. Thus, each loop is randomly connected to 3 other loops. The network can then be perturbed in various ways to see whether or not it is able to adapt.

Addressing the specific code implementation of all these details is outside the scope of this paper, but javascript code implementing these aspects (used to generate the previous image), is available here: <https://github.com/Tyfoods/minimal-enerstatic-network>

At this point, there are a couple guidelines that may need a bit more clarity with respect to their motivation. The first is that idea that an enerstatic loop has a set of structures which it can assemble, and disassemble and the second is the nature of the structures themselves. The organizational nature of an enerstatic loop is meant to capture the idea from assembly theory that information about how to construct particular structures is embodied by what we would call living things. This information embodiment is what allows assembly theory to characterize life as that which produces a high copy of structures above a particular complexity threshold, and furthermore to place different living things on different points on the “life continuum”. Structures are an abstraction of enerstatic loops that allow one to specify the function of such loops without referring to the various control system details that we have previously discussed. We are allowed to do this because these structures represent enerstatic loops that are kept consistently at their homeostatic set point and thus exert the same causal power consistently. We take the assumption that the enerstatic loop that these structures are a part of considers structures outside of homeostasis to be “defunct” and thus disassembles them. What will be discussed next is what a learning algorithm could look like in an enerstatic network.

## Learning in Enerstatic Networks

In our minimal enerstatic network, each loop was extremely sensitive to any perturbations in its energy level. In other words, any fluctuation in internal energy resulted in “action” being exercised by the loop. In our case, this action was in the form of causal power exhibited by our single effector. There is another sort of action that can take place, and this action is with respect to the reconfiguration of the enerstatic loop. If we allow our enerstatic loop to reconfigure itself, and give it time to test the consequences of its new architecture, then we can employ some sort of learning algorithm.

A great way to give enerstatic loops time to test the consequences of their actions is through implementing two “windows”, or ranges, inside of its allowed energy levels. These two windows are the “stasis Window”, and the “action Window”. The stasis window is a set of numbers around the energy set point of the enerstatic window in which the loop’s architecture goes unchanged. The size of the window defines how much time, or tolerance, a loop has before it takes the action of reconfiguring its architecture. The action window is a set of numbers around the positive and negative bounds of the stasis window which indicate that the loop should attempt to reconfigure its architecture.



# Energy Level Meter

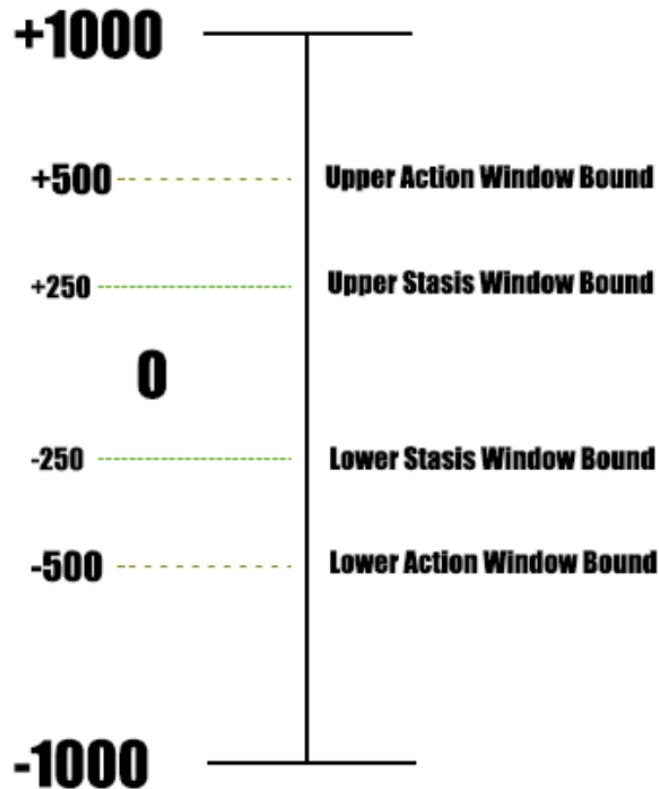

- Enerstatic window parsed into two separate windows: The stasis window in which no action is taken, thus the loop is considered stable, and the action window, in which the loop is considered unstable, and must take action to return to a stable state.

Now that we know when we will reconfigure the enerstatic loop, we are now tasked with defining under what particular modification/action will be made, how many of those modifications will be made and under what circumstances. A simple approach is to define a probability associated with each action, and to allow for only one action to be made per time step. In other words, when the loop is pushed into the action window, each possible action has a probability associated with it, which determines whether or not that action is the action selected on that time step. However, it is not necessarily true that an action **MUST** be taken on any given time step if a loop is in its action window. This can be left up to the programmer and isn't important for our conceptual discussion here.

The question the programmer must ask next is: "When and how should I update my beliefs, or probabilities?" In this example, we answer both of these questions by introducing yet another window, the "Change Action Probability" (CAP) window. Collectively, these windows are known as enerstatic windows. The CAP window allows for probabilities to be changed in a sort of last ditch effort to attain stasis. Since the goal is to change action probabilities in such a way that result in a return to stasis, it would be reasonable to come up with a complicated algorithm that attempts to predict what actions should be modified, however, inspired by plasticity mechanisms in neurons, we can opt for simple associative hebbian-like learning. During the action window, the loop can integrate the information, or series of steps that led to the loop being pushed into the CAP window. In particular, the loop can be made to remember the actions that were taken as well as what the energy level was when each action was taken. Instead of looking any deeper at the details of this data, our simple associative hebbian-like learning algorithm strengthens, or weakens all actions taken in the action window based on whether those actions led to the stasis window, or the CAP window. In this way, probabilistic sequences of actions that helped are strengthened, while probabilistic sequences of actions that

hurt, are weakened. Furthermore, the particular energy level at which the action was taken could be recorded to allow for an even more detailed belief updating.

While exploring the space of possible enerstatic networks is an interesting, and potentially valuable, task in its own right; Modeling physical phenomena is a powerful way to both gain insight into existing SOULS as well as build new even more heavily nature-inspired SOULS. As an example, we extend the concept of an enerstatic network to model the function of neurons.

## Modeling Neurons: Enerstatic Neural Networks

Before conceptually detailing how one might go about modeling neurons with enerstatic networks, it is important to understand the motivation behind the approach in the context of biology because it may apply generally to all cells. The goal of modeling cells as enerstatic networks is to investigate if such an idea can serve as a guiding principle to understanding the behavior of cellular collectives. In the particular case of neurons, understanding brains. Neurons were the main inspiration in the development of the enerstatic network due to the observation that neurons are, for the most part, lifelong cells that collectively take up 20% of the body's energy budget [14, 20]. The question that this provoked was: "Given that we see neurons that exist over the lifetime of an organism, what would that neuron's behavior have to be like in order for it to do so?" This paper suggests that the answer is "behavior which regulates the neuron's energy level within a certain homeostatic window".

Indeed a neuron with low enough levels of ATP will not even be able to carry out apoptosis and instead will undergo necrosis [57]. On the contrary, high levels of ATP in a neuron can facilitate cytotoxicity and ultimately cause cell death [16], or cause disruptions in protein synthesis, which can also lead to cell death [42]. This demonstrates the importance of ATP as the "physiological variable" that the "control system" that is the neuron, regulates.

If the primary objective of a neuron is to control its energy level, then one could say that "information processing" in a neuron is "built on top" of the mechanisms that a neuron uses to regulate its energy level. In this case, it would be the case that trying to understand the way neurons process information would be frustrated by the fact that neurons are energy management systems first, and information processors second. There is indeed evidence demonstrating an informative relationship between energy efficiency and function [39, 45]. More generally, if all cells that exist must meet this existential imperative, then it could often make sense to model and understand them with enerstatic networks. In this perspective, all cells don't know what "computations" they're involved in, or what their role is in the development and operation of the organism they are embedded in. Cells only try to exist for as long as possible given their environment. The purpose of the structures that cells assemble and maintain is primarily to allow those cells to maintain their energy within a homeostatic window. This frustration is indeed one and the same as that which is caused by the "Behavioral illusion" discussed in "IOS Illusions: Motivating Modeling With Enerstatic Loops". We now turn to an example of using enerstatic networks to model neurons.

Since computational experiments with enerstatic neural networks are currently in progress, and the purpose of this section is only to inspire ways of modeling biological SOULS with enerstatic networks, only the general conceptual details of the project will be discussed.

Enerstatic neural networks are just minimal enerstatic networks except for the fact that the structures that loops in an enerstatic neural network assemble are analogous to those in neurons to the programmers desired level of complexity. Using the requirements for an enerstatic network, we can specify our conceptual model as follows:

1. There is a flow of energy into the system that depends on the action of that system
  - Neurons receive blood flow, or energy, only when they are stimulated. This is inspired by neurovascular coupling (NVC).
2. This energy flow results in the establishment of an energy distribution, where energy is higher and lower in different parts of the system in the form of other enerstatic loops, or "structures". The establishment of this energy distribution represents the system starting out "alive" I.E. in a non-equilibrium steady state.
  - Each neuron starts out with a suite of structures such as ion channels, receptors, axons, dendrites, genes etc.... Each structure occupies a different point in space and costs a variable amount of

energy to create.

3. This energy flow results in the aforementioned internal energy distribution being modified in some way
  - Energy is captured and released by mitochondria which despite their motility, are unequally distributed about the neuron. This results in local pockets of high and low energy.
4. There is an inevitable loss of energy as the system generates entropy
  - Neurons have a “causal power” cost that is defined as a function of the structures they’ve assembled.
5. Structures can only be assembled at these energetic points
  - Only local areas with high enough energy are capable of assembling structures.
6. There are rules defining the space of possible structures.
  - As mentioned during our minimal enerstatic loop exercise, the cost of structure assembly, disassembly, and causal power are up to the programmer, but can be determined through empirical measurements. Similarly, conditions under which a structure exerts its causal power can be determined either way. Thus, for brevity, and because it is besides the point for this example, specific values/conditions have been left out.

- **Structures**

- **Macrostructures**

1. Genes - It is important to note that a genome doesn’t necessarily specify all possible structures in the space of our program.
  - **Structural Genes** - Produces a particular “physical” structure which modifies the loop’s architecture.
  - **Regulatory Genes** - Specifies how gene expression (causal power exertion) in one gene affects the expression of other genes.
2. Soma
  - Geometrically represented as a sphere with some diameter specified by the genes
  - Membrane potential specified by genes
3. Axons
  - Geometrically represented as a 2 or 3D lines
  - Membrane potential specified by genes
4. Dendrites
  - Geometrically represented as 2 or 3D lines
  - Membrane potential specified by genes

- **Microstructures**

1. Voltage Gated Ion Channels - Voltage sensitivity specified by genes. Activates when the membrane potential of the structure it is embedded in reaches a certain threshold. When activated, either depolarizes (raises), or hyperpolarizes (lowers) the membrane potential of the cell; the degree to which this lowering happens is specified by the genes.
2. Ligand Gated Ion Channels - Activated when in contact with some particular neurotransmitter specified by the genes. When activated, either depolarizes (raises), or hyperpolarizes (lowers) the membrane potential of the cell.
3. ATPase pumps - Consume a certain amount of energy per time step thus causing local energy demand.
4. Neurotransmitters - Upon contact, activates particular ligand gated ion channels as specified by the genes.

5. Mitochondria
    - Moves around according to energy gradients, preferentially going where energy is low.
    - Receives energy upon receiving blood flow and outputs energy to the local area.
  6. mRNA - Instructions sent out by the nucleus to ribosomes which detail which structure to assemble.
  7. Ribosomes
    - Moves according to energy gradients, preferentially going where energy is high.
    - Upon contact, and given sufficient local energy, translates mRNA into a structure.
7. When the system is unable to perform actions that allow for an appropriate flow of energy, the system dies I.E. falls into equilibrium.
- When neurons hit their fatal energy threshold, they undergo apoptosis and shut down shop. In particular, all their associated structures are removed from the program.

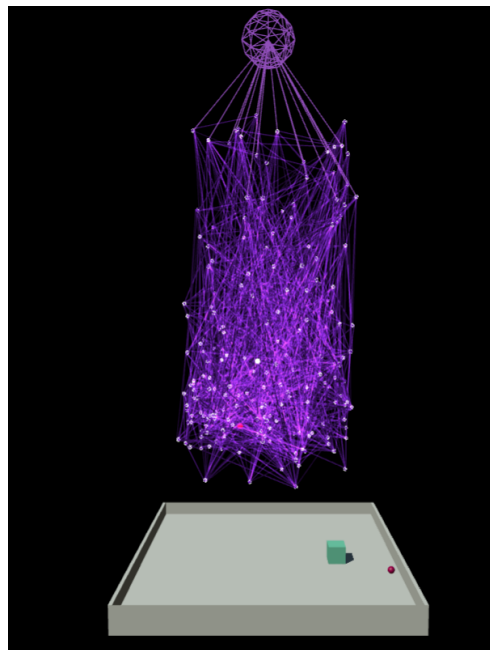

- Visualization of an ongoing experiment featuring an enerstatic neural network receiving visual inputs in the form of a “Sparse Distributed Representation (SDR)” [3]. The enerstatic neural network must control the ball and the camera embedded in the ball to accomplish two things: (1) Recognize food (2) Move towards food – Otherwise, it dies. This makes enerstatic networks a great candidate for open-ended evolution.

As mentioned, one can be as biophysically detailed with model parameters as they’d like. This may result in important insights as to the inner workings of their actual biological counterparts. However, when discussing the creation of technology, it has been evidenced by advances in artificial intelligence, that one needn't bother with setting all parameters, and structural details, as accurately as possible to yield something that is both technically useful, and worthy of scientific inquiry. Indeed, despite being dramatically simpler than real biological neural networks, Artificial Neural Networks have been used to gain insights into their behavior. Modeling physical phenomena with enerstatic networks thus potentially provides a way to both understand those phenomena and use the resulting technology to do something useful.

An interesting way to use enerstatic neural network models to generate more biologically relevant results, might be to map abstraction layers onto each other. For example, a Hodgkin Huxley Neuron (HHN) is less complicated than a biological neuron (BN), but empirical data can be used to fit a HHN to a BN. Similarly, one could then use empirical data generated by the HHN neuron to map onto yet an even simpler neuron

model. This may allow one's model to be much more relevant to experimental inquiry. Such abstraction layer mapping is part of the ongoing computational experiments involving enerstatic neural networks.

Further ongoing experiments are in the domain of applying open-ended evolutionary techniques to enerstatic networks in general. The advantage of using enerstatic networks as a tool for building technologies is its natural symbiosis with such techniques. As previously mentioned, open-ended evolution requires building blocks with a particular kind of dynamics which allow for an increase in complexity through the construction of ever larger building blocks as selected for by an intelligence which is itself constructed and amplified from within the system. This selection mechanism is built into enerstatic loops by default making them great candidates for open-ended evolution.

## Evolving Enerstatic Networks

The key properties that make enerstatic loops, and therefore enerstatic networks, symbiotic with open ended evolutionary techniques can be summed up in the following way: Enerstatic loops can only persist their existence if they are able to modify their architecture in real-time in such a way that they take in more energy than they lose.

If the only way that enerstatic loops can receive energy is by successfully organizing themselves in particular ways based on the environment that they are embedded in, then there is no need to specify particular rewards for particular tasks because such rewards are intrinsic to their nature. With currently available tools, this makes it difficult to engineer an enerstatic network to do exactly what you'd like it to do, but it does open the doors of opportunity to evolving networks that both achieve your desired behavior and exhibit behaviors you may have never come up with yourself.

The goal of open-ended evolution is to generate seemingly never-ending complexity as we observe in our universe. The challenge of developing a system with such behavior is centered around the environment-agent dilemma. The dilemma is that, as an agent embedded inside some environment becomes more complex, or intelligent. It essentially masters the environment thereby maxing out its own complexity and intelligence. Thus, arguments have been made for creating environments that complexify along with the agent that is embedded inside of it [55, 50]. While seemingly straightforward, the problem of how to continuously complexify the environment along with the agent, without periodic injection of some outside intelligence (I.E. programmer intervention), has been elusive.

A large part of the problem is how the encoding of the environment operates. Although, there exist universal encodings for certain domains like mazes, or 2D landscapes. The problem with expanding beyond particular environmental domains seems to persist. In their paper, the authors of Evolution through Large Models (ELM) propose that: "computer programs are a general and powerful encoding for continually expanding the richness of an existing environment." and takes a critical step towards demonstrating how use of raw computer programs could be used to ensure open-endedness indefinitely [27]. In their paper, they develop a particular methodology that results in a program that is able to conditionally output computer programs which they call an "invention pipeline". In short, the methodology consists of three steps:

1. Use any arbitrary large language model (LLM) to provide intelligent mutations to an evolutionary algorithm (In this case, the quality diversity (QD) algorithm, MAP-Elites) to generate training data in a domain where little, or none, exists.
2. Pre-train the LLM with aforementioned training data, such that it can now output similar data
3. Use reinforcement learning, and some additional tweaking, to fine tune the LLM such that it is able to produce data based on the condition that it is exposed to.

This methodology captures a few key elements that we believe are key to indefinite open-endedness, which are as follows:

1. Increasingly intelligent (correlated) mutations over indirect encodings, which are nonetheless, just code.
2. Generation of a diverse amount of novel structures without the use of a trained neural network.
3. The creation of an agent that is able to create structures conditionally based on its "needs".

Although different in form, It is these elements that evolutionary enerstatic networks aim to achieve.

## Energetically closed systems

Fundamentally, enerstatic networks are meant to capture the idea that any “thing” that exists is an “energetically open system”. An energetically open system is a system that takes as input some finite amount of energy, and outputs only a fraction of that amount of energy. Specifically our energetic open systems consisted of an extension of these three rules:

1. There must be a source of energy flowing into the system
2. There must be mechanisms that essentially trap energy inside the system.
3. There must be mechanisms responsible for energy flowing out of the system

In this setting, we had a rather static environment that was not capable of becoming much more complex in response to the complexity of our enerstatic network. However, we have mentioned that as a consequence of the information symmetry of the free energy principle, the environment must also be treated as an agent capable of, in a sense, increasing its complexity [13]. One way to realize this information symmetry is to treat the environment itself as an enerstatic loop. In this case, we now have an “energetically closed system”. This paper suggests that using such an approach, along with methods like ELM, is critical to the development of truly open-ended processes. Our energetically closed system follows these rules:

- Some finite amount of energy exists inside the system
- Energy cannot be created nor destroyed
- Energetically open system rules previously specified apply to all structures within the system\* (We’ll later see a small exception, but it’s mostly correct).
- Environment is modeled as an enerstatic loop that minimizes free energy (I.E. the energy not currently trapped within a structure)
- Environmental enerstatic loop (EEL) is responsible for building structures within it

In order to get a better grip on the approach being developed here, it is best to run a sort of simulation, or thought experiment, over what we could feasibly do within the bounds of our required specifications interspersed with motivations for why we might choose to do things in that particular way. Of course, there are many particular ways, much of which can be co-opted for application to energetically open systems. Following the theme of this paper: The following is a thought experiment whose iterations are currently in development – Consider this to be “food for thought” rather than a definitive “how to” guide.

### Causal Niches

At first, we only have an environmental enerstatic loop (EEL), whose "goal" is to minimize free energy. Since all energy is free at first, the first thing the loop "wants" to do is trap energy within structures. The first structure that it generates,  $S_0$ , must necessarily have causal power such that the environment recreates it. To actually implement this, we will require that our EEL has a property which details how much energy each structure inside it should be receiving each timestep. The default amount of energy is 0. Thus, in order to exist  $S_0$  must sense this particular property and set it equal to its requisite free energy demand (FED), or higher. There are three scenarios here for any given structure:

1. If the structure receives less than its FED, it ceases to exist.
2. If the structure receives exactly its FED, it persists its existence.
3. If the structure receives more than its FED, and this energy is not explicitly used, then this energy remains trapped unless explicitly moved by some other “thing”.
  - a. Importantly, the structure must receive less than its free energy limit (FEL), which places a bound on the amount of energy a structure can contain.

Recall that this dynamic is in alignment with our aforementioned reasoning with respect to structures inside of an enerstatic loop. Structures inside a loop are abstracted enerstatic loops that are kept consistently at their homeostatic set point and thus exert the same causal power consistently. We take the assumption that the enerstatic loop that these structures are a part of consider structures outside of homeostasis to be “defunkt” and thus disassemble them.

Importantly,  $S_0$  is **only** capable of interacting with EEL and no other structure ( $S_n$ ). This is due to the fact that it is not possible to explicitly specify an interaction of  $S_0$  with the unknown properties of a yet non-existent structure. However,  $S_0$  can interact with future structures indirectly through its effect on the environment. This restriction of only being able to interact with structures that have been previously generated remains true for every subsequent structure, which gives us a graph illustrating the causal niche of each generated structure. A causal niche is defined as the set of properties that a structure can sense and affect.

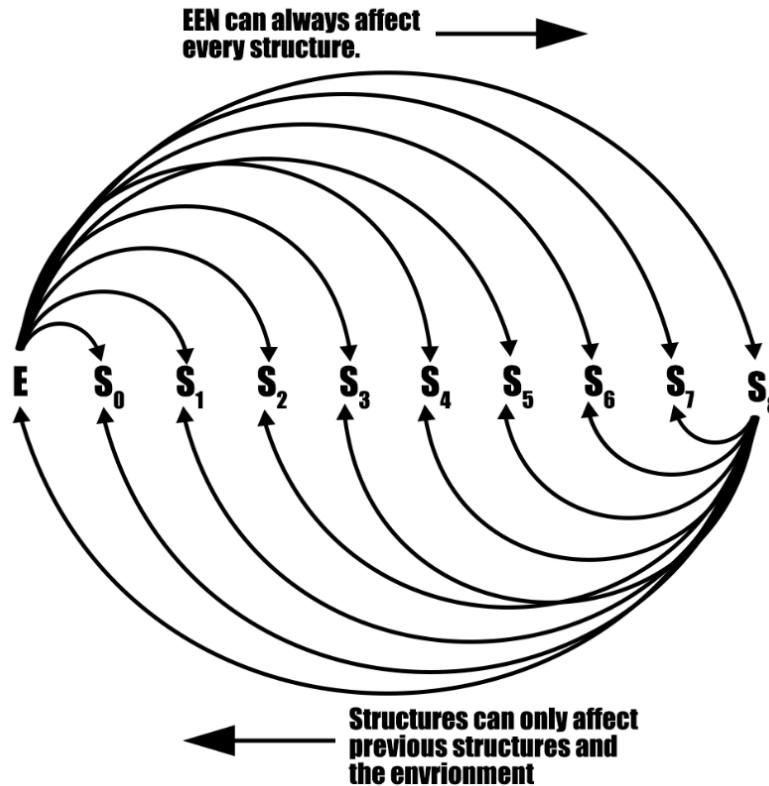

- Causal Niche Graph demonstrating that structures can only affect the environment and previous structures that have been created. Illustrated here are the arrows for structure 8 and the environment, which can always affect every structure.

The reason that structures are defined like this is because the alternative is intractable, or at minimum, much closer to the practice of inducting the laws of physics. The reasoning is as follows: In order to generate a structure that is capable of explicitly affecting a future structure, one needs to have a medium (i.e. universal method of communication) that is able to underwrite those particular specifications. This medium is what every structure “lives in” and operates through. A good analogy for better understanding is with the case of a physics engine. In a physics engine, we are typically only concerned with Newtonian physics, in other words, with the question of “What happens when object A bumps into object B?”. Since the underlying physics are known, one doesn’t need to worry about which object was created first in order to have the objects interact properly. The laws of physics that detail how forces act on objects in order to move them, are known. In our case, the laws of physics are not known, and thus the interaction between two “objects” need to be explicitly defined via code which defines the object's causal power.

The requirement of explicitly specified interactions is important for explainability. There have indeed been efforts for exploring possible open-ended evolutionary systems using basic universal rules which constitute the system’s “laws of physics”. Three notable systems are n-dimensional discrete cellular automata, continuous cellular automata, and hypergraphs. The issue here is that, not only can we not guarantee open-ended evolution, but that even if we managed to achieve it, it would be difficult to understand what is happening in a way that is human-interpretable. Therefore, using explicitly specified interactions via code, despite such a restriction, will be important for understanding both what is going on, and potentially, for how to inch closer to open-ended evolution in a principled manner.

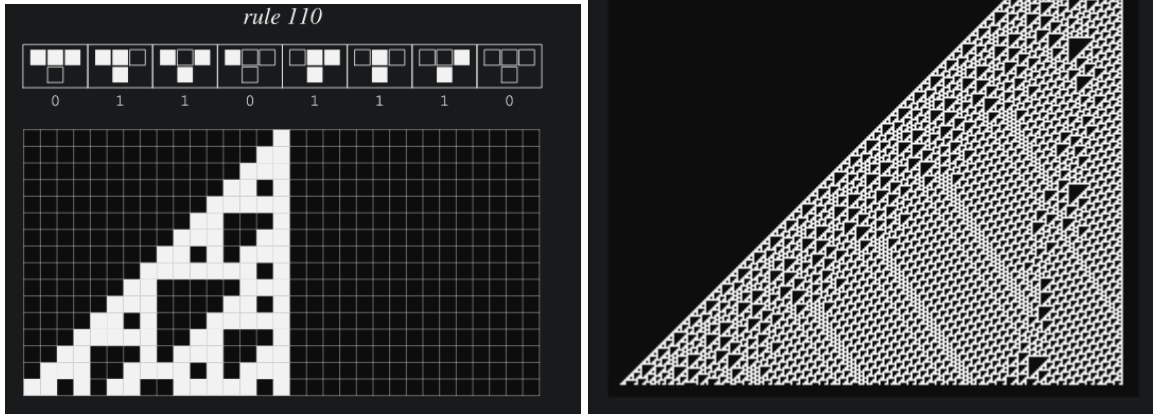

- 1D cellular automata called “Rule 110” demonstrating the amount of complexity one can achieve from running a simple rule over a simple initial condition. Despite starting with a single black cell and a simple rule for determining how each cell changes color (It does so only based on its immediate neighbors), one ends up with unpredictable, and potentially never-ending, complexity. In other words, simple rules can give rise to arbitrarily complex behavior. Indeed, rule 110 was found to be capable of “universal computation”, in other words, like a typical computer, you can use rule 110 to run any possible computer program. The problem here is the difficulty in encoding and interpreting the program. Interestingly, simply exploring the space of possible simple programs has revealed patterns that are similar, at a macro-level, to the kinds that have been found in nature. As a related note, Stephen Wolfram heads a research program focused on discovering a fundamental theory of physics by exploring the space of possible simple hypergraph programs, which are essentially even simpler versions of cellular automata. Through this exploration, Wolfram Research has been able to mathematically derive essential features of special relativity from hypergraphs, such as Lorentz transformations and the speed of light as a universal speed limit [56]
- On the left, the rules of the program and the first 16 steps, on the right, the first 250 steps. We start from a single black cell on the first row and apply the rule to each cell in the row to generate the next row.
- Source: Weisstein, Eric W. "Rule 110." From MathWorld--A Wolfram Web Resource. <https://mathworld.wolfram.com/Rule110.html>

### Structure specifications

As illustrated in our causal niche graph, we have a total of 9 structures generated, but they’re completely abstract. All we know is that the minimum requirement for each structure is that there must be a cost of assembling/disassembling, causal power (and its associated cost), effective radius and a position that they occupy in space. There are other properties that one can apply to these structures, which could either be ubiquitous to all structures, or defined uniquely only to some structures.

In the case of ubiquitous properties, the thought is that these should be directly computable in some way from the aforementioned properties so that they remain related to the specifications of that structure. For example, the mass of a structure could be calculated based on the energetic cost of the structure using  $E = mc^2 \rightarrow E/c^2 = m$ , where  $E$  = energy,  $m$  = mass, and  $c$  = constant speed of light, or cosmic speed limit. Furthermore, position could then be modified as a function of mass, where the position of an object requires a certain amount of energy to be perturbed. This could be calculated using:  $W = (1/2) * m * v^2$  where  $W$  is the work done on the object,  $m$  is the mass of the object, and  $v$  is its final velocity. The amount of energy required to perturb a property’s value by “1” unit is here called the “perturbation energy” and is important for energetically grounding any property whether it is unique, or ubiquitous.

An example of a unique property might be “membrane voltage”. The property should minimally have a



default value, and a perturbation energy, however a third likely important characteristic is a “location” within the causal power of the structure. This will allow the causal power of a structure to be modified through perturbations of structure properties. One could imagine utilizing current membrane voltage to decide whether to send a message, or not. For this reason, we’ll refer to such properties as “causal properties”. Similar to how equations that have been empirically discovered were used to decide how to modify the position of any structure, equations which describe how difficult it is to modify membrane voltage could be implemented. Thus, such properties can assist in generating an energetically closed system that is not just interpretable, but also bears semblance to our physical reality thus potentially serving as a powerful modeling tool. However, it must be noted that this is not without the cost of dramatically increasing the complexity of implementation. As for actually defining these properties, this is something we’d like to leave to an automated task.

### **Automatic structure generation**

The causal niche graph allows us to generate structures continuously in a principled way. We can fill niches with various kinds of structures in each causal niche. Since each causal niche restricts only the sensed input properties and affected output properties, the actual causal dynamic that implements the sensed information and affects the output properties is up to us. To offload this work, we take a hint from ELMs usage of Large Language Models (LLMs). In effect, we’ve created a function that has certain inputs (sensed set of properties), potential internal variables (causal properties), and outputs (affected set of properties), and we’d like to use a Large Language Model to fill in the details about how inputs and internal variables produce on output. Utilizing LLMs, the environment can create a set of structures with various causal dynamics in every niche – The limit of structures within a niche is up to the programmer. As for the effective radius, the LLM can be used, or the programmer can opt to assign effective radii based on some particular algorithm or criteria.

In addition to arguing that the goal of the environment is to minimize its free energy, this paper also suggests that one good way to do this is for the environment to actually test different sets of structures concurrently to see which sets of structures combine to make complex composite structures capable of minimizing VFE. Those that fail to minimize VFE well enough get outcompeted and thus end up with a lower likelihood of being created in the future.

Before discussing how structures can mix and match in this way, it is important to discuss a mechanism for automatically assigning energy costs to such structures.

### **Automatic energy cost assignment**

Previously, we assigned energy costs to structures either using intuition or empirical data from experimentation in the service of modeling. The caveat is that one needs to be careful not to violate the constraint that energy cannot be created or destroyed. With this in mind, it is possible to do something similar to what we did before, but we can also opt for a different method that allows for automation. The benefit of assigning energy costs automatically is not just to avoid the work of doing so, but also to allow for energetic consistency throughout various created structures. In other words, similar causal powers have similar energetic costs. This provides us with a sort of “underlying physics” that our enerstatic program must obey. It should be noted that this same technique can be applied to energetically open systems of enerstatic networks as well, but may be less straightforward to apply in the context of modeling.

In order to automatically assign energy costs to structures, we first make the claim that the cost of structure assembly and disassembly are equal and opposite. Furthermore, the cost of structure assembly is equal to the cost of causal power. Since causal power is just a function whose body is code that has been generated by an LLM, we can take that code and convert it into an “Abstract Syntax Tree” (AST). An AST is a simplified representation of a piece of code that is typically constructed by a compiler, or interpreter as a way of efficiently analyzing and processing source code. Technical details aside, the AST allows us to calculate the number of fundamental operations, or primitives, that are inside of the code defining our causal dynamic. With knowledge of all the possible operations in our programming language of choice, we can assign energy costs to each of these operations and then calculate the total amount of energy that our causal dynamic costs. Toggling these costs among inside of, and between, different programming languages opens up an interesting domain of study. As for causal properties, the cost of these must be calculated using their perturbation energy function. Such a function receives the current value of the property and returns the amount of energy

required to modify that value. One can then calculate the cost of the property by starting at 0 and iteratively summing the costs as it is raised to the default value. Thus, causal properties represent stored energy.

**Structure recombination - Information, and intelligence, are physical.**

As had been mentioned in the “Enerstatic Loops, Networks and Nests” section, the concept of an enerstatic loop is meant to capture the idea that information required to reliably produce a structure is physically embodied by such a loop. Additionally, we suggested that a structure by itself is indeed an enerstatic loop, whose possibly varying architectures have been abstracted away due to that structure being deemed “stable”, or useful to the loop in which it is embedded, only when it is in one particular form of stasis. This paper argues that the dynamics of enerstatic loops are to be taken as a ubiquitous consequence of laws of physics which dictate what relationships are stable between constituent structures at every scale. Thus, enerstatic loops are to be understood as inter-structure relationships whose stability depends upon (1) the interaction between the structures, and (2) the particular local environment that the loop is in. Here, environment refers to both the EEL and every other structure that is “sufficiently outside” of the enerstatic loop in question in the sense that the structures inside the enerstatic loop only have sparse, weak, or otherwise unstable, relationships with structures outside the loop. The way that these relationships form is simple. When one structure is within another structure's effective radius, a relationship is formed. This relationship constitutes the embodiment of information about the structures present in the relationship. The following image illustrates what such sparse relationships could look like.

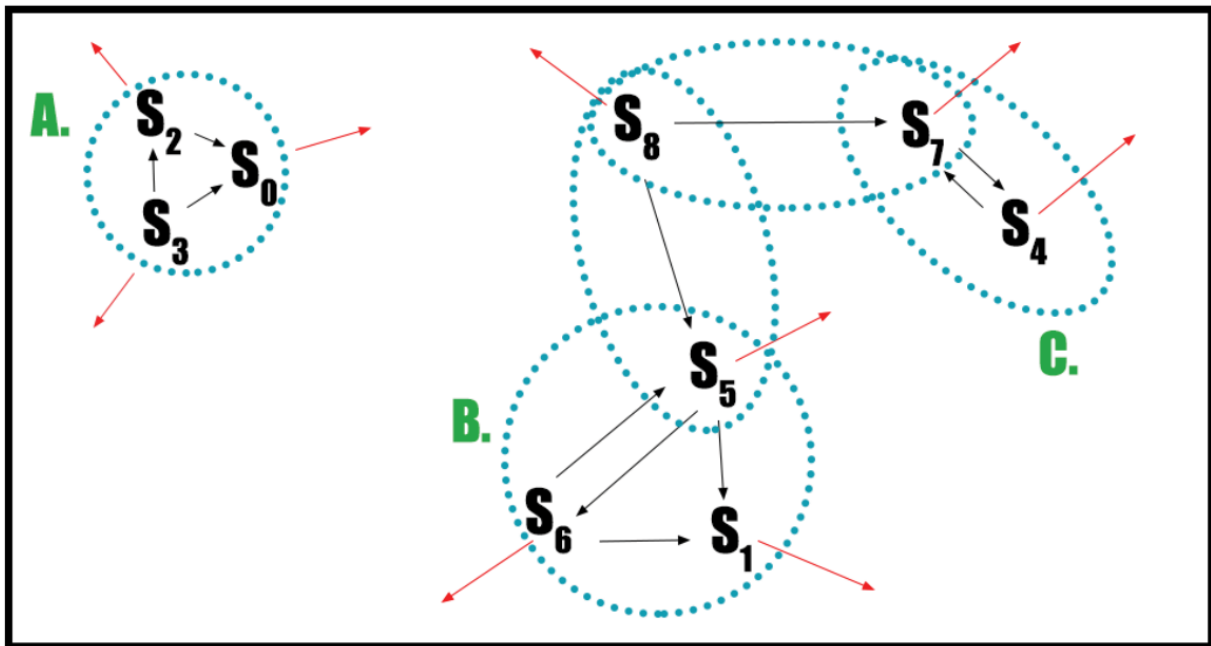

- Illustration of structures that have been created inside the “Environmental Enerstatic Loop (EEL) and have established relationships with each other”. Red arrows show the impact of structure causal power on the environment, while black arrows indicate the impact of structure causal power on other structures. Dotted blue line indicates the enerstatic loops, which are to be understood as relationships between structures. Structures are in a relationship only when structures affect each other.
- Loop A structures have no relationship with any other structure. Loop B & Loop C have sparse relationships with structure S<sub>8</sub>, as they are affected, but don’t affect S<sub>8</sub>.

As before, each enerstatic loop has an “Enerstatic Window” consisting of a “Stasis Window”, “Action Window” and “Change Action Probability Window”, however, instead of limiting loops to only be capable of creating structures that they have already come into contact with, we allow loops to create any structure that has been already “invented” by the EEL. This further breaks down the distinction between loop and environment by treating each loop as a sort of mini EEL in itself. Thus, what makes each enerstatic loop sufficiently

different from other loops is their differing probability distribution with respect to what actions each loop will take given its energy level. In this way, relationships break down when structures move too far away from each other, when the action taken disassembles a structure, or when energy flowing through the loop is either insufficient to sustain its dynamics, or higher than the loop is capable of dissipating.

Defining the enerstatic window is again something that we'd like to do automatically. For this, we take another look at our abstract syntax tree (AST). Our abstract syntax tree allowed us to calculate the free energy demand (FED) of any structure, but it also allows us to calculate the free energy limit (FEL) of any structure. These define the amount of energy a structure requires to maintain its existence, and the maximum amount of energy a structure is capable of dissipating, respectively. Knowing these values for every structure in an enerstatic window, as well as their connectivity, we can create a function that allows for the calculation of the lower and upper energy bounds of our enerstatic window. Using such a calculation, our lower enerstatic bound is equivalent to the smallest amount of energy required to sustain the system, while the upper enerstatic bound is equivalent to the largest amount of energy that can be dissipated through the network. Outside of these bounds, the loop breaks down through the loss of structure.

### Summarizing

We started off with an environmental enerstatic loop (EEL), which consisted of a pool of “free energy”, a large language model (LLM) used to produce the causal structures within “causal niches”, an energetic mapping used to assign energetic costs (FEDs), and limits (FELs) to each structure, and finally a description of the way structures make, break and adjust relationships a la enerstatic loops. Each of these elements is flexible when it comes to the specifics of how it is implemented. The amount of free energy the EEL starts with, the way causal structures are generated, the way energy costs are mapped onto logical code, and of course, the way structures recombine and adjust their relationships, can all be varied. Specific implementations do not reflect the Ensoul framework. They only reflect particular ways of executing the framework. That being said, the core idea here is to develop energetically closed systems that generate structures which are increasingly interesting, intelligent, and “alive” as generally defined in the “Open-Ended Evolution and Assembly Theory” section.

Quantum computing demonstrates that it may not be practical, or even desirable, to physically create perfectly energetically closed systems, however, it might be that approximations to such systems would serve as powerful ways to both more easily generate intelligent technology in the physical world, and serve as models for understanding the evolution, and dynamics, of thermodynamically open systems more deeply. Before diving into creating the physical manifestations of such devices, it is important to first demonstrate their capabilities in the computer, and use such model systems to inform the creation of them.

What we've effectively done in this paper is to make code physical by creating an underlying “energetic physics” on top of which our code is built. In other words, “structures” are code that has been manifested into an energetically constrained virtual realm. This is in alignment with the idea that everything in the physical world can be said to be “computing”, and is therefore describable via computations possible by a universal Turing machine. This has been called pancomputationalism [4]. While it is not clear that everything in the physical world is computable; it is also not clear that we have any other choice but to use mathematical and computational tools to understand it.

So far, the discussion has been about what we can do inside of a computer in order to create SOULS. These simulations are important for the development of software based technology, in its own right, however, simulations of energetically closed systems using conventional Von-Neumann architecture IOS severely underutilize the true computational capacity of the materials being used. This underutilized computational capacity, is what we referred to in “IOS Illusions: Motivating Modeling With Enerstatic Loops” as “highly variable behavior”, or “noise”. This property of materials that engineers have painstakingly avoided can actually function as useful computational processes if one takes the right approach. Systems that embrace noise as a computational resource have been called “Thermodynamic Computers” (TCs). These computers are SOULS in physical reality and truly bring us closer to the “Ultra Low power” part of the SOULS definition.

## Thermodynamic Computing & Enerstatic Networks

Thermodynamic computers have been envisioned as an “engineered, multi-scale, complex system that, when exposed to external potentials (inputs), spontaneously transitions between states in the short term

while refining its organization in the long term, both as part of an inherent, adaptive process driven by thermodynamics “ [33]. This is analogous to what we’ve described as the behavior of enerstatic networks, but in physical form. This paper argues that the collection and study of manifestations of this general concept will prove to be important for understanding the problem of embedded agency. In this section, we will briefly touch on thermodynamic computers, the relationship between thermodynamic computing and enerstatic networks, and finally, embedded agency.

Thermodynamics is a branch of physics that deals with the relationships between the various different forms of energy such as heat and work. It was originally developed in order to optimize the amount of energy extracted from steam engines [9]. This application of thermodynamics focuses on states of “equilibrium” in which the state of a system is homogenous and macroscopically unchanging, such as a pool of still water. Indeed, one of the conclusions drawn from thermodynamics is that the entire universe is evolving towards such an equilibrium state in the so-called “heat death of the universe”. In spite of this conclusion, many physicists have come to believe that thermodynamics is also chiefly responsible for driving the organization of life as we know it [47, 46]. This has spurred the development of “Non-equilibrium Thermodynamics”, which is thought to be the type of thermodynamics that life, and many other complex systems that are far from equilibrium, seem to employ. In particular, work on fluctuation-dissipation theorems and information thermodynamics have been continuing to generate insights into understanding life and the development of thermodynamic computers.

One of the issues in thermodynamic computing is the lack of a unifying general model system that can properly express thermodynamic computing. While there are existing model systems such as Hopfield Networks, Boltzmann Machines, thermodynamic neural computation models, and Thermodynamic Neural Networks; These models have been regarded as only “a small set of interesting and suggestive devices and architectures [9]”. Although there remains much work to be done with respect to this area of research, this paper suggests that enerstatic networks may be a general enough model to serve as such a unifying general model system. This kind of system is critical for the evaluation of core theoretical concepts, like fluctuation-dissipation theorems, and information thermodynamics, the demonstration of problems that are best solved using such approaches, and as a helpful reference for the development of thermodynamic computers.

The reasoning behind speculation that enerstatic networks might serve as such a model is based on the fact that their components – enerstatic loops – are ultimately extremely simplified abstractions of thermodynamically open systems whose level of detail can be straightforwardly scaled up through the use of empirically measured values and integration of empirically derived mathematical equations.

Given the existence of SOULS, whether they are virtual, physical, engineered, or evolved, and the need to control, or take advantage of said SOULS, one needs a proper framework, or way of thinking, with which to do so. This brings us back to TAME – A Technological Approach to Mind Everywhere – which provides many such ideas and beliefs in order to accomplish just that.

## Taming SOULS

While it is trivially true that the goal of any “thing” is to exist, it is apparent that “things” also seem to have “higher level” goals that very much seem to have little to nothing to do with existence in particular. For example, a person who chooses to summit Mt. Everest or to run in a 135 mile race through death valley in the scorching hot sun doesn’t quite seem to be taking the most optimal path towards a continued existence.

### Deceptive higher level goals

This paper argues that the pursuit of existence can be deceptive in a way that is perhaps analogous to the way the path to a particular goal can be deceptive as we discussed with the training of the biped. That is to say, the path to existence appears to be divergent rather than convergent. The invariant multi-scale TAME approach suggests an interesting way of describing this seeming inconsistency.

First of all, any “thing” is made up of parts whose goal is to exist. For many things, particularly those we consider “more alive”, those parts are not densely connected to each other. In other words, each part is not directly causally connected to every other part. Considering that the coherence of a “self” is determined by the degree to which parts share stress, certain parts can be partitioned as belonging to different “things”, or in other words, to some degree, constituting separate “selves”. A relatable example is the fact that biological

organisms are made up of cells (parts), which cluster together in such a way as to be called different tissues (things), which then differentially cluster to be called organs, and so on. As previously discussed, when resources are limited, achieving the goal of existence necessarily induces resource limitations for other “things”, since there is less free energy to utilize. So, the thing about not directly sharing stress with other parts, is that it now becomes possible for parts of any “thing” to compete with each other over resources despite ultimately belonging to the same “thing”.

However, the possibility of competition does not imply competition must be happening. In other words, despite having the ability to strictly compete and perform actions that would be detrimental to the collective as a whole, persistent collectives of cells achieve consensus through a combination of cooperation and competition, which we will refer to here as “coopetition”. The consensus that arises from coopetitive dynamics are rather nicely illustrated by financial markets, and companies, in which individuals, and populations of individuals, only acting according to their own local interests, are able to achieve stable market prices and can ensure that all involved balance their books. Coopetition operates at all scales of collective intelligences, from organelles, to cells, to tissues, to organs and so on. According to Dr. Stephen Grossberg’s work in such coopetitive systems, there is a trade off between how free parts are to make certain decisions, and the size of the global decision that can be made. This restriction can result in the existence of multiple choices in a network, in which a novel choice can be preferred, and in oscillatory, or “jumps”, between different decisions, or parts, that are currently “winning” the competition [9, 18, 17, 19]. Both of these phenomena contribute to interesting, complex adaptive behavior as the collective in question takes actions which in favorable cases allow the collective to survive. Dr. Grossberg proved a theorem about this dynamic that allows for the design of such systems called the “Adaptation Level System theorem”. As an incredibly simplistic example, one might understand this in the following way: For our climber, reaching the summit of Mt. Everest is bad for some populations of cells in the collective, but great for the survival of other populations. The populations of cells that benefit from this behavior are “winning” the competition, but this is balanced by yet other populations “winning” the competition once the mountain has been descended thus all parties involved balance their books.

Now we have an idea behind what might in many cases be the cause of seemingly existentially-irrelevant behavior of “things”. Essentially, it is dependent on the coopetition between parts within a “thing”, which can be called “parts” as a function of the degree to which their constituent pieces share stress. The task is then to figure out how one can identify the goals, or purpose of the decisions, made by the collective. Such an endeavor enables us to better characterize, engineer and work with such collectives.

## Taming SOULS and Cognitive Capacity Tests (CCTs)

Perceptual Control Theory (PCT) is a version of control theory that is dedicated to understanding naturally occurring control systems, or SOULS. PCT asserts that:

“A natural control system can be organized only around the effects that its actions (or independent events) have on its inputs (broadly defined), for its inputs contain all consequences of its actions that can conceivably matter to the control system [43]”.

Powers well describes this concept in just a few words saying that “behavior is the control of perception (inputs)”. In other words, actions are taken in service of ensuring that the “thing” perceives what it “wants” to perceive. In PCT, this desired perception is called the “reference signal”, and critically, is thought of as being internally generated as opposed to externally generated as it is in most artificial control systems. As an example of this externality, the value of the temperature that a thermostat is trying to regulate, depends on the reference signal given to it by its user and typically is not modifiable by the thermostat itself. For a natural control system the reference signal is always modifiable by the “thing” itself. Consider again the non-analytical solution to the outfielder problem known as “Optical Acceleration Cancellation”. The natural control system, in this case the outfielder, presumably comes to choose the variable that they are controlling. That same control system can work towards controlling a number of other variables all towards solutions of different tasks making its position on the cognitive continuum much farther to the right than a simple thermostat.

## **Test for Controlled Variable (TCV)**

The protocol for inferring the controlled variable of any control system is the same whether it is natural, or artificial. Under the PCT, this protocol is called the “Test for Controlled Variable (TCV)”. TCV allows one to identify both the type of system that one is looking at (IOS vs SOULS), and, if present, the variable(s) that the SOULS is controlling. The TCV process is an iterative empirical process through which a hypothesis about what variable is being controlled is tested. The hypothesis takes the following form: “If variable X is the variable under control, then variable X should experience less than usual effect upon being disturbed”. Temperature under the control of a thermostat provides a straightforward example. Provided your AC was on, opening a window on a chilly day would slowly cause a decrease in temperature, which would soon be countered by the thermostat’s activation of the heating mechanism. This is not what would be expected if the thermostat was not controlling temperature as a variable and constitutes the temperature experiencing a “less than usual effect upon being disturbed”. A non-trivial application of TCV was in the identification of “control of optical velocity (COV)” over “optical acceleration cancellation (OAC)” as the better explanation for how organisms solve the outfielder problem [33]. These two variables, velocity and acceleration are closely related, as such, it is difficult to disturb one without disturbing the other. In order to help sway interpretations in a single direction, two model control systems were made that each implement control of only one of these variables. The OAC model accounted for 75% of the variance in the path of an organism intercepting an object, while the COV model accounted for 93% of the variance. This suggests that optical velocity, rather than optical acceleration, is the variable actually being controlled during object interception. TCV rules out the possibility that the system we are studying is an IOS by confirming that no variable is under the control of that system’s behavior. In the case of something like our “odd thermostat”, which is a thermostat that regulates temperature with its output only 50% of the time, the application of statistical methods along with TCV can allow us to gauge where on the IOS vs SOULS continuum our system lies.

While TCV allows us to figure out what variable the system is controlling during some particular task, it does not tell us the entire set of variables a control system is capable of controlling, nor does it tell us how we might modify the value of reference signal of the systems controlled variable, or how we might induce the system to switch between different controlled variables. Such inquisition might lead us to coming up with a “Test for Variable Controllability (TVC)” and a “Test for Control Switches (TCS)” respectively. We’ll now briefly discuss how these could work.

## **Test for Variable Controllability (TVC)**

Test for Variable Controllability (TVC) attempts to answer the question: “What variables that I am capable of measuring are this system capable of sensing?”. This framing makes it clear that the observer is chiefly responsible for properly inferring the system’s cognitive capacity. Like TCV, TVC starts with a hypothesis about some set of measurable variables lending a credence to each one. The testing amounts to sensor identification and subsequent inference about what sensory partitions the control system might make. In other words, identifying the location and type of sensor, as well as what these sensors could amount to sensing as a collective (i.e. light detection (small scale), vs perception of an entire object (large scale)). A simple example is inferring that based on having eyes a creature might be able to detect individual objects. Although non-trivial, the task is important to mapping out the spatial dimension of a system's “cognitive light cone”, which is a system's spatiotemporal computational capacity towards attaining a particular goal. The temporal dimension is intimately related to the spatial dimension. In TVC we ultimately care about what type of measurable variable the system expends energy towards controlling as well as about how far disturbances can be in space and time and still evoke a change in the system’s actions. In short, the TVC should work towards mapping a system's cognitive light cone by starting from the theoretical maximum and conducting experimental tests to cut down on possibilities.

## **Test for Control Switch (TCS)**

Test for Control Switch (TCS) is a test that is meant to identify the method that one should use to modify the value, and/or identity, of the variable that the system is controlling. TCS is related to the “axis of persuadability” concept presented by TAME. Recall that the position of a system on the axis of persuadability represents the level of complexity at which intervention is required to get a system to do what you’d like it to do. The farther to the right the system is on the axis of persuadability, the less energy one has to expend. In other words, a good control switch is one that ultimately allows one to expend as little energy as possible. As

such, TCS should test for switches at different levels of cognitive capacity starting from the highest potential cognition whose cognitive light cone was inferred via the TVC. In short, TCS would ask:

1. Can I communicate with the system with some language through some medium?
2. Can I identify rewards for this system which to use for training purposes?
3. Are their setpoints which I could modify using some physical means?
4. Would I really have to reduce it into pieces and refashion it together from scratch to get it to do what I want?

The emphasis here is to avoid underestimating the intelligence of a system. One excellent example demonstrating the power of a control switch is found in the demonstration of morphological control through modification of a bioelectrically embodied setpoint [31]. The lab of Dr. Michael Levin, and their collaborators, established the bioelectrical state of cells as instructive to their collective target morphology through a few key examples. First, it helps to know that cells are typically more negatively charged inside the cell than outside the cell. The charge, or voltage, inside a cell can be measured and visualized. This allows us to see the impact of certain drugs, or other interventions on the collective bioelectrical state of some cells. The first of Levin’s experiments that we will mention is in flatworms. Flatworms are complex organisms that exhibit bilateral symmetry and have a nervous system. They also have spectacular regenerative abilities. Flatworms can be cut in two, which causes each half to develop into perfectly good flatworms. A piece of flatworm as small as 1/279th the size of the animal has been demonstrated to regrow into a fully viable adult flatworm [38]. Through visualizing the bioelectrical state of the cells one can actually induce a severed planaria to have two heads rather than one by manipulating the cells of the “should be” tail. Two tailed flatworms have been made in this way, flatworms with heads from other flatworm species, and even flatworms with heads that are presumably non-existent in flatworm nature as we’ve known it thus far. Importantly, once these bioelectrical manipulations are made, the flatworm remembers the state upon being severed once again. In other words, once severed, a two headed flatworm begets two, two headed flatworms. This is despite the genome not being modified in any way. This represents a powerful control switch for biological organisms. In the same vein was in the case of tadpoles which can be bioelectrically manipulated in order to have an eye on their tail. Not only is an eye on the tadpole’s tail with no genetic modification, the cells of the tadpole actually organized themselves towards making the eye functional from a relatively simple local signal [41]. Tadpoles original eyes were blinded to demonstrate that it could still navigate with the tail-eye [6]. Further evidence of bioelectrical cell state as a control switch was in the creation of so-called Xenobots. Xenobots were created by Levin in collaboration with Dr. Josh Bongard. Xenobots are simply what one gets when the skin cells of a frog are liberated from the electrical signals they normally get from the rest of the body during development. Once liberated, these cells coagulate to form a proto-organism that reproduces itself by physically moving other cells around it into similar proto-organisms. These phenomena make it clear that bioelectrical states of cells act as a setpoint that controls their behavior. Indeed, Levin demonstrated that certain cancers can be effectively cured by forcing cancer cells to reintegrate electrically with the collective [8].

Identifying a system’s cognitive light cone and control switches are both big tasks, but the reward certainly justifies the work involved. Controlling a system by rewiring its hardware should only be resorted to when absolutely necessary. The competence of naturally occurring control systems should make it clear that the intelligence of the parts that make up natural control systems should be properly assessed in order to determine the most efficient way to understand and leverage its behavior towards a particular goal. Importantly, these tests all have usages towards the understanding and development of thermodynamic computers. Making all of these tests more rigorous and formalizable is an aim of TAME and a major motivation for this paper. A model that can capture the self-organizing dynamics of thermodynamically driven complex adaptive systems would serve as the ideal test bed for theoretical calculations in the development of empirical tests/statistics and in the development of more biologically, or rather, thermodynamically, inspired technological advancements. We now recap the desired perception(s) driving all of this behavior and discuss future directions.

## Discussion: Research Directions, Speculations and Philosophy

### Summarizing Ensoul

“Given that we see neurons that exist over the lifetime of an organism, what must it be really good at doing in order to do so?” – This paper suggested that that thing was “managing its energy level”, in which case,

analysis of its behavior assuming any other purpose would frustrate such analysis. However, information processing certainly seems to be just what neurons do. Thus, is it possible to build systems in which information processing, or “work”, is done as a consequence only of a “thing” managing its energy level? Might this concept relate more generally to what we observe in physical reality? – This paper answered affirmatively to both of these questions. The generalization of this concept led to the thermodynamically inspired abstraction, the enerstatic loop. The core driving force being that, any “thing” which exists, and persists in its existence, must be participating in something that allows for that persistent existence. In other words, it must have causal power, and that causal power must either be embedded in the self-evidencing behavior of some other “thing”, or must itself exhibit some degree of self-evidencing behavior. This scheme implies that any persistent thing is well understood as a control system in which negative feedback maintains what would otherwise be broken down and that this dynamic is intrinsically generated by the parts which make up that system.

Following such a scheme, this paper leaned into pancomputationalism, the idea that such causal power can always be written down formally and is computable. However, actually writing such code by hand is non-trivial due to the simultaneous considerations of energy and information processing. Additionally, the findings in open-ended evolution make it clear that the path to a desired outcome isn’t always best found with optimization (convergent) techniques. Fortunately, enerstatic loops are well suited to open-ended evolution due to their existential imperative and capacity for information processing. Mapping energy costs to code (A process one might call “deabstracting”, or “physicalizing”), the use of large language models, the power of assembly theory as basis for complexity measures in evolutionary systems, and the noted information symmetry posited by the free energy principle makes the exploration of “energetically closed systems” a promising avenue for the understanding, and generation of, models of thermodynamically open systems based on enerstatic loops. Given the abstract substrate-independent nature of such energetically closed systems, and their generated energetically open systems, the term “Self Organizing intelligent Ultra Low Power System (SOULS)” seemed a fitting description for both such entities.

The understanding of “things” such as SOULS illustrate the need for an existentially-based multi-scale perspective on reality, a perspective which focuses on the invariant concepts that can be consistently applied to every “thing” at every scale. Technological Approach to Mind Everywhere (TAME) serves as an important framework for taking such a perspective. As a result, the concepts of “intelligence”, “cognition”, “goals”, “stress”, “self”, “life”, and “feedback” are defined on a continuum, rather than with discrete categories. We ask not if the “thing” has these properties, but of “what kind”, and of “how much” [30]. This is critical for developing an understanding of complex systems, one that specifically allows us to understand how these concepts scale up, and what the macroscopic result of such scaling looks like.

It is clear that the influence of technological advancements on humanity have been increasing exponentially in their rate of development with no apparent end in sight. The results of these advancements have often been unpredictable with both positive and negative consequences. As such, the development of the technology described in this paper is meant to serve two purposes: (1) The generation of practical technologies that can be put to use and, (2) to serve as a test bed through which negative consequences can be better understood and mitigated. Understanding the consequences of such technology is a non-trivial task, but it is critical that we be able not just to build it, but to control it. Lack of understanding of the consequences of our current technologies have resulted in things like loss of privacy, addiction to social media and unprecedented political influence. At the same time, there are strong arguments that the overall quality of life, including for those in impoverished conditions, has significantly improved as a result of technological progress and increased global interconnectedness. This makes the development of a framework like TAME alongside the development of SOULS both an existential, and utopic, imperative. The faster the development of our understanding, the better chances we have of intentionally shaping the consequences of our technological advancements. This leads us to considering important future research directions.

## Future directions

Briefly, future directions include:

1. Using conventional von-Neumann computers to implement enerstatic programs, perhaps via FPGAs, or other flexible classical computing approaches.
2. The development of specialized versions of enerstatic programs aid as a test bed in the development of thermodynamic computers through advancement of theoretical/mathematical frameworks.



3. The development of specialized versions of enerstatic programs to assist in the understanding of biological systems, an example of which was the enerstatic neural network described in this paper.
4. The development of rigorous measures of intelligence, interestingness, and “aliveness” (complexity) in energetically closed enerstatic programs such that different programs can be compared and autonomously analyzed.
5. The development of TAME, and more specifically, the development of rigorous cognitive capacity tests (CCTs), (i.e.. existential measures of intelligence/cognition, test for controlled variable (TCV), test for variable controllability (TVC), and test for control switch (TCS).
6. Finally, if deemed necessary, the creation of alternative methods than the use of Large Language Models for the generation of structures in energetically closed systems.

## Speculations and philosophy

The contents of this paper were written in an attempt to put together ideas that may be key to advancing the understanding and development of science and technology. To that end, this paper embraced substance monism, process philosophy, pancomputationalism, and an extended version of the strong life-mind continuity thesis. Philosophy is essential because the way that we think of the world influences the way that we act in that world, which importantly, includes how we conduct scientific research. As such, we now step through some of the philosophy motivating the development of Ensoul.

Substance monism suggests that everything is made up of “one thing”, which seems to then motivate the question: “Why do we see distinct ‘things’ if everything is made up of one thing?” and “How do these things come into being?”. While this paper provides no answers beyond “it is just so”, it does suggest physically and logically grounded guidelines as to how to simulate the behavior of such “things” as well as how to go about evolving systems with such “things”. The following argument suggested a way about how to go on:

1. Physics has told us that  $E=mc^2$ , in other words, that every “thing”, is made up of energy.
2. The way that we understand the behavior of “things” is through cause and effect.
3. A “thing” cannot be said to exist, if it has no effect. In other words, to exist is to be the cause of an effect (eleatic principle).
4. Similarly, a “thing” cannot be said to be persisting its existence if there is no cause(s) for its existence. In other words, to persist is to be the effect of a cause (Persistence principle).
5. Therefore, we are to model “persistent things” as having persistent causes, of which they themselves may be the cause. In other words, to model their existential and self-evidencing causal powers.

This leads to a continuous vision of “things” that have various degrees of what one might call “existential feedback”. This is what happens when a “things” effect is part of its cause. Indeed, if this is not the case, then it must be the case that something else causes it, which itself must be caused by itself, or something else. Therefore, we form the hypothesis that things which cause their own existence have a more prevalent/sustained existence. These “things” are well understood as negative feedback systems, or control systems. The interesting thing about the nature of these natural control systems, is that they are regulating their own particular dynamics, or causal power, rather than any one particular measurable variable. This view is well in line with process philosophy which suggests no “thing” is static, but is always changing. This paper uses this necessary dynamic of “changing” in combination with the eleatic principle and principle of causality to motivate existential circular causality, or existential feedback loops, as proper abstractions for such systems. In doing so, it leans into pancomputationalism and the continuity thesis proper.

Pancomputationalism, like process theory, suggests that the physical world can be understood as a process, however, it specifically suggests that this process is a computational one. That is, a cause and effect process that can be simulated on a computer. The reason this paper leans into this notion is two fold: (1) If we are to understand the nature of reality we must use the language of cause and effect as its automation in computational devices has helped extend our cognition in ways we could have never thought possible, and (2) This sort of approach might provide strong evidence that pancomputationalism cannot be sufficient through the demonstration that properties which we typically describe as “emergent” truly cannot be described as being computationally attainable by the fundamental constituents of that phenomenon.

In leaning towards the idea that these properties can indeed be found as computationally attainable by the dynamics of the fundamental “stuff” that makes up the universe, this paper embraces the strong life-mind continuity thesis [25]. The strong life-mind continuity thesis suggests that the origin of life is synonymous with the origin of mind. In other words, once you have life, you have a mind. This paper attempts to operationalize familiar properties such as intelligence and cognition as dependent on a “things” self-evidencing causal power. It is on these grounds that the efforts encouraged by this paper rest.

The challenge at hand is to use the abstraction of an existential feedback loop as a tool to understand how such operationally defined properties scale up into the forms that we are familiar with, as well as discover how the dynamics of such loops can be leveraged in the creation of new technologies and understanding of life as it might be. To this end, embracing evolutionary approaches along with traditional approaches to the creation of enerstatic loops, networks and nests in virtual and physical spaces may prove to be a fruitful area of exploration.

A final word, one should be careful not to mistake the map for the territory. Philosophy, theories and models of reality are not equivalent to reality despite their predictive power or believability. The situation that we find ourselves in is one in which we seemingly cannot truly know what is behind the causes of our senses [21]. Philosophy, theories and models are ultimately just stories we tell ourselves about those possible hidden causes. SOULS is a term that just so happens to fit well for any "thing" that persists its existence while abiding by the stories asserted by process philosophy and substance monism. As such, we can ask whether taken metaphysically, the notion of SOULS can have application in giving the colloquial word “soul” a more rigorous definition. Philosophically speaking, Ensoul would seem to suggest that a soul is any causal force that is persistent over time. Thus, approaches like Ensoul, which use existential feedback loops may be considered a sort of implementable philosophical model, one in which this philosophical story might be better understood. Stories represent our subjective beliefs about what is happening in reality and as such the stories that we tell ourselves guide what we do in both life and science. Thus, while it is important to acknowledge that these stories are not equivalent to reality, these stories, should we believe them, are equally important, considering the power that these stories have over the sorts of actions that we take in the world. Interestingly, the word “psychology” was originally defined as “the study of souls” before becoming more commonly recognized as the “study of minds”. Indeed, the word “psychology” is made from the combination of the Greek words “psychē” (meaning “breath, principle of life, life, soul”), and “logia” ( meaning “speech, word, reason”). One of the aims of Ensoul is to take seriously the idea that some of the properties one studies in psychology, like intelligence and cognition, are not just present in the human mind, but in all “things”, or SOULS. As such, methods and ideas from psychology such as PCT and reinforcement learning can be useful in understanding the nature of any “thing” independent of what that “thing” is made up of. This might suggest an extension, or reinterpretation, of psychology that one might call “neopsychology”, or the “new study of the SOULS”, where what we are primarily interested in are these measurable substrate-invariant operationally defined properties of any “thing” (i.e. intelligence, cognition, stress level, etc) and how they scale up, or in what cases, if any, certain properties can be said to "emerge". Since this paper primarily takes a modeling, or construction approach to understanding SOULS, the framework has been named “Ensoul” which is a verb meaning “to endow with a soul”.

## References

- [1] Manipulating belief in free will and its downstream consequences: A meta-analysis. 2022.
- [2] Stephen Adams, Tyler Cody, and Peter A. Beling. A survey of inverse reinforcement learning. *Artificial Intelligence Review*, 55(6):4307–4346, February 2022.
- [3] Subutai Ahmad and Jeff Hawkins. Properties of sparse distributed representations and their application to hierarchical temporal memory. 2015.
- [4] Neal G. Anderson and Gualtiero Piccinini. Pancomputationalism and the computational description of physical systems. February 2017.
- [5] Saurabh Arora and Prashant Doshi. A survey of inverse reinforcement learning: Challenges, methods and progress. *Artificial Intelligence*, 297:103500, August 2021.
- [6] Douglas J. Blackiston and Michael Levin. Ectopic eyes outside the head in xenopus tadpoles provide sensory data for light-mediated learning. *Journal of Experimental Biology*, 216(6):1031–1040, March 2013.
- [7] Seville Chapman. Catching a baseball. *American Journal of Physics*, 36(10):868–870, October 1968.
- [8] Brook T. Chernet, Chris Fields, and Michael Levin. Long-range gap junctional signaling controls oncogene-mediated tumorigenesis in xenopus laevis embryos. *Frontiers in Physiology*, 5, January 2015.
- [9] Tom Conte, Erik DeBenedictis, Natesh Ganesh, Todd Hylton, John Paul Strachan, R. Stanley Williams, Alexander Alemi, Lee Altenberg, Gavin Crooks, James Crutchfield, Lidia del Rio, Josh Deutsch, Michael DeWeese, Khari Douglas, Massimiliano Esposito, Michael Frank, Robert Fry, Peter Harsha, Mark Hill, Christopher Kello, Jeff Krichmar, Suhas Kumar, Shih-Chii Liu, Seth Lloyd, Matteo Marsili, Ilya Nemenman, Alex Nugent, Norman Packard, Dana Randall, Peter Sadowski, Narayana Santhanam, Robert Shaw, Adam Stieg, Elan Stopnitzky, Christof Teuscher, Chris Watkins, David Wolpert, Joshua Yang, and Yan Yufik. Thermodynamic computing. 2019.
- [10] Jamie Davies and Michael Levin. Synthetic morphology via active and agential matter. June 2022.
- [11] Thomas Doctor, Olaf Witkowski, Elizaveta Solomonova, Bill Duane, and Michael Levin. Biology, buddhism, and AI: Care as the driver of intelligence. *Entropy*, 24(5):710, May 2022.
- [12] Chris Fields, Karl Friston, James F. Glazebrook, and Michael Levin. A free energy principle for generic quantum systems. *Progress in Biophysics and Molecular Biology*, 173:36–59, September 2022.
- [13] Chris Fields and Michael Levin. Regulative development as a model for origin of life and artificial life studies. October 2022.
- [14] Steven A Frank. Input-output relations in biological systems: measurement, information and the hill equation. *Biology Direct*, 8(1), December 2013.
- [15] Karl Friston, Lancelot Da Costa, Noor Sajid, Conor Heins, Kai Ueltzhöffer, Grigorios A. Pavliotis, and Thomas Parr. The free energy principle made simpler but not too simple. 2022.
- [16] Mandi Gandelman, Mark Levy, Patricia Cassina, Luis Barbeito, and Joseph S. Beckman. P2x7 receptor-induced death of motor neurons by a peroxynitrite/FAS-dependent pathway. *Journal of Neurochemistry*, 126(3):382–388, June 2013.
- [17] Stephen Grossberg. Competition, decision, and consensus. *Journal of Mathematical Analysis and Applications*, 66(2):470–493, November 1978.
- [18] Stephen Grossberg. Biological competition: Decision rules, pattern formation, and oscillations. *Proceedings of the National Academy of Sciences*, 77(4):2338–2342, April 1980.
- [19] Stephen Grossberg. Behavioral economics and neuroeconomics: Cooperation, competition, preference, and decision making. In *The 2013 International Joint Conference on Neural Networks (IJCNN)*. IEEE, August 2013.
- [20] Julia J. Harris, Renaud Jolivet, and David Attwell. Synaptic energy use and supply. *Neuron*, 75(5):762–777, September 2012.

- [21] Donald D. Hoffman, Manish Singh, and Chetan Prakash. The interface theory of perception. *Psychonomic Bulletin & Review*, 22(6):1480–1506, September 2015.
- [22] Jakob Hohwy. The self-evidencing brain. *Noûs*, 50(2):259–285, March 2014.
- [23] Jacek Izidorczyk. Three steps to the thermal noise death of moore’s law. *IEEE Transactions on Very Large Scale Integration (VLSI) Systems*, 18(1):161–165, January 2010.
- [24] Kuno Kim, Shivam Garg, Kirankumar Shiragur, and Stefano Ermon. Reward identification in inverse reinforcement learning. 139:5496–5505, 18–24 Jul 2021.
- [25] Michael D. Kirchhoff and Tom Froese. Where there is life there is mind: In support of a strong life-mind continuity thesis. *Entropy*, 19(4):169, April 2017.
- [26] Laszlo B Kish. End of moore’s law: thermal (noise) death of integration in micro and nano electronics. *Physics Letters A*, 305(3-4):144–149, December 2002.
- [27] Joel Lehman, Jonathan Gordon, Shawn Jain, Kamal Ndousse, Cathy Yeh, and Kenneth O. Stanley. Evolution through large models. 2022.
- [28] Joel Lehman and Kenneth O. Stanley. Abandoning objectives: Evolution through the search for novelty alone. *Evolutionary Computation*, 19(2):189–223, June 2011.
- [29] Michael Levin. The computational boundary of a “self”: Developmental bioelectricity drives multicellularity and scale-free cognition. *Frontiers in Psychology*, 10, December 2019.
- [30] Michael Levin. Technological approach to mind everywhere: An experimentally-grounded framework for understanding diverse bodies and minds. *Frontiers in Systems Neuroscience*, 16, March 2022.
- [31] Michael Levin and Christopher J. Martyniuk. The bioelectric code: An ancient computational medium for dynamic control of growth and form. *Biosystems*, 164:76–93, February 2018.
- [32] Warren Mansell, editor. *The interdisciplinary handbook of perceptual control theory the interdisciplinary handbook of perceptual control theory*. Academic Press, San Diego, CA, May 2020.
- [33] Richard Marken, Richard Kennaway, and Tauseef Gulrez. Behavioral illusions: The snark is a boojum. *Theory & Psychology*, 32(3):491–514, January 2022.
- [34] Richard S. Marken and Dennis M. Shaffer. The power law of movement: an example of a behavioral illusion. *Experimental Brain Research*, 235(6):1835–1842, March 2017.
- [35] Stuart M. Marshall, Cole Mathis, Emma Carrick, Graham Keenan, Geoffrey J. T. Cooper, Heather Graham, Matthew Craven, Piotr S. Gromski, Douglas G. Moore, Sara I. Walker, and Leroy Cronin. Identifying molecules as biosignatures with assembly theory and mass spectrometry. *Nature Communications*, 12(1), May 2021.
- [36] Stuart M. Marshall, Douglas G. Moore, Alastair R. G. Murray, Sara I. Walker, and Leroy Cronin. Formalising the pathways to life using assembly spaces. *Entropy*, 24(7):884, June 2022.
- [37] Stuart M. Marshall, Douglas G. Moore, Alastair R. G. Murray, Sara I. Walker, and Leroy Cronin. Formalising the pathways to life using assembly spaces. *Entropy*, 24(7):884, June 2022.
- [38] T. H. Morgan. Experimental studies of the regeneration of planaria maculata. *Archiv für Entwicklungsmechanik der Organismen*, 7(2-3):364–397, October 1898.
- [39] Jeremy E Niven. Neuronal energy consumption: biophysics, efficiency and evolution. *Current Opinion in Neurobiology*, 41:129–135, December 2016.
- [40] Graham Oddie. Armstrong on the eleatic principle and abstract entities. *Philosophical Studies*, 41(2):285–295, March 1982.
- [41] Vaibhav P. Pai, Sherry Aw, Tal Shomrat, Joan M. Lemire, and Michael Levin. Transmembrane voltage potential controls embryonic eye patterning in xenopus laevis. *Development*, 139(2):313–323, January 2012.
- [42] Mauricio H. Pontes, Anastasia Sevostyanova, and Eduardo A. Groisman. When too much ATP is bad for protein synthesis. *Journal of Molecular Biology*, 427(16):2586–2594, August 2015.

- [43] William T. Powers. Quantitative analysis of purposive systems: Some spadework at the foundations of scientific psychology. *Psychological Review*, 85(5):417–435, September 1978.
- [44] William T Powers. *Behavior: The Control Of Perception*. Benchmark Publications, 2 edition, March 2005.
- [45] Michiel W. H. Remme, John Rinzel, and Susanne Schreiber. Function and energy consumption constrain neuronal biophysics in a canonical computation: Coincidence detection. *PLOS Computational Biology*, 14(12):e1006612, December 2018.
- [46] E.D. Schneider and J.J. Kay. Life as a manifestation of the second law of thermodynamics. *Mathematical and Computer Modelling*, 19(6-8):25–48, March 1994.
- [47] Erwin Schrodinger. What is life?: With mind and matter and autobiographical sketches. June 2013.
- [48] Abhishek Sharma, Dániel Czégel, Michael Lachmann, Christopher P. Kempes, Sara I. Walker, and Leroy Cronin. Assembly theory explains and quantifies the emergence of selection and evolution. 2022.
- [49] Lakshwin Shreesha and Michael Levin. Competency of the developmental layer alters evolutionary dynamics in an artificial embryogeny model of morphogenesis, 2022.
- [50] L. Soros and Kenneth Stanley. Identifying Necessary Conditions for Open-Ended Evolution through the Artificial Life World of Chromaria. ALIFE 14: The Fourteenth International Conference on the Synthesis and Simulation of Living Systems:793–800, 07 2014.
- [51] N. Stepp and M.T. Turvey. On strong anticipation. *Cognitive Systems Research*, 11(2):148–164, June 2010.
- [52] Richard C Tolman. *Relativity, thermodynamics and cosmology*. Dover Books on Physics. Dover Publications, Mineola, NY, March 2003.
- [53] Jan Toman and Jaroslav Flegr. Stability-based sorting: The forgotten process behind (not only) biological evolution. *Journal of Theoretical Biology*, 435:29–41, December 2017.
- [54] Henry Veatch. Aspects of scientific explanation and other essays in the philosophy of science. *Philosophy of Science*, 37(2):312–314, June 1970.
- [55] Rui Wang, Joel Lehman, Aditya Rawal, Jiale Zhi, Yulun Li, Jeff Clune, and Kenneth O. Stanley. Enhanced poet: Open-ended reinforcement learning through unbounded invention of learning challenges and their solutions. 2020.
- [56] Stephen Wolfram. A class of models with the potential to represent fundamental physics. 2020.
- [57] M V Zamaraeva, R Z Sabirov, E Maeno, Y Ando-Akatsuka, S V Bessonova, and Y Okada. Cells die with increased cytosolic ATP during apoptosis: a bioluminescence study with intracellular luciferase. *Cell Death I& Differentiation*, 12(11):1390–1397, May 2005.

# Glossary

- **Assembly Theory** - A physical theory of life which allows one to categorize and detect life through measurement and application of a recursive algorithm. The theory places different life forms on a spectrum of complexity.
- **Axis of persuadability** - the notion that every “thing” lies on a continuum with respect to the amount of effort it takes to control that thing. The amount of effort required is inversely proportional to the complexity/size of the “things” cognitive light cone.
- **Cognition** - Operationally defined in this paper as the degree to which a “thing” can “sense”, “believe” and “act”. In other words, the complexity associated
- **Cognitive Capacity Tests** - Describes a suite of tests used to determine the cognitive light cone of any “thing”. Some tests include: Test for controlled variable (TCV), test for variable controllability (TVC), and test for control switch (TCS).
- **Cognitive Light Cone** - describes how far in space and time an event can be and still have an affect on the computations being enacted by some system.
- **Enerstatic Loop** - Short for “Energy Homeostatic Loop”, which is an abstraction of a control system that learns to regulate its own “energy level”, or particular dynamics, through the modification of its own structure. It maps onto the idea of an adaptive thermodynamically open system, or adaptive dissipative structure. Enerstatic loops represent “relationships” between “structures”
- **Ensoul** - Acronym for “Enerstatic Network approach to Self Organizing intelligent Ultra Low Power Systems”, a framework that this paper proposes in order to better understand the nature of reality.
- **Environmental Enerstatic Loop (EEL)** - Short for “Environmental Enerstatic Loop”, which is an abstraction utilized to implement energetically closed systems. The EEL is responsible for creating structures and enerstatic loops.
- **Feedback** - The degree to which a thing’s effect, or “output”, affects its cause, or “input”
- **Framework** - A framework is a set of rules, ideas, or beliefs that you employ in order to solve problems or make decisions.
- **Free Energy Principle** - A mathematical formalization of the properties that any self-organizing system must have.
- **Goal** - The desired result of a thing’s behavior (i.e. causal power).
- **Intelligence** - Operationally defined in this paper as the adaptive capacity of a “thing” to meet its “goal” of existence.
- **Life-Mind Continuity Thesis** - The philosophical idea that life and mind emerged simultaneously and have since then manifested themselves in increasingly complex ways.
- **Neopsychologist** - “the new study of SOULS” - potential term for one who uses the framework and approaches written in this paper. Specifically, one who is primarily interested in studying measurable substrate-invariant operationally defined properties of any “thing” (i.e. intelligence, cognition, stress level, etc).
- **Open ended evolution** - The process through which new “things” are generated for a seemingly indefinite period of time. This process is believed to be embodied by our universe and is well described by assembly theory.
- **Pancomputationalism** - The metaphysical idea that every “thing” that exists can be understood as “computing” something.
- **Self** - A collection of parts that share degrees of stress
- **Self-Evidencing** - The verb form of “self-evident”; an explanation is self-evidencing if the event which it explains provides key evidence for the explanation. What any “thing” does provides key evidence for its own existence via an existential feedback loop.

- **SOULS** - Acronym for “Self Organizing intelligent Ultra Low Power System(s)” meant to capture the multi-scale substrate independent nature of “things” that Ensoul focuses on understanding and utilizing to create novel technologies.
- **Stress** - Any effect that pushes a “thing” away from its “preferred”, or “healthy”, state.
- **Substance Monism** - The metaphysical idea that every “thing” is made up of the same sort of “stuff”
- **IOS** - Acronym for “Input Output System(s)” meant to capture SOULS whose “fluctuations”, or, goal-directed behavior, have been squelched.
- **TAME** - Acronym for “Technological Approach to Mind Everywhere” a framework developed by Michael Levin to understand diverse bodies and minds.
- **Teleology** - Purposeful, or goal directed, behavior.
- **Teleonomy** - Behavior that is not truly goal directed, but looks “as if” it is.
- **von-Neumann architecture** - A computer architecture based on a 1945 description by John von Neumann. This is the architecture that most computers today are based on. It has evolved to mean any “stored-program computer” in which an instruction fetch and a data operation cannot occur at the same time.