



PRIVACY CONCERNS FROM VARIANCES IN SPATIAL NAVIGABILITY IN VR

PREPRINT, COMPILED FEBRUARY 7, 2023

Aryabrata Basu ¹, Mohammad Jahed Murad Sunny ¹, and Jayasri Sai Nikitha Guthula ¹

¹Department of Computer Science, University of Arkansas at Little Rock

ABSTRACT

Current Virtual Reality (VR) input devices make it possible to navigate a virtual environment and record immersive, personalized data regarding the user’s movement and specific behavioral habits, which brings the question of the user’s privacy concern to the forefront. In this article, the authors propose to investigate Machine Learning driven learning algorithms that try to learn with human users co-operatively and can be used to countermand existing privacy concerns in VR but could also be extended to Augmented Reality (AR) platforms.

1 INTRODUCTION

Navigating spaces is an embodied experience. Spatial navigation in a VR environment requires auditory, visual, and or tactile sensation to explore the virtual space intertwined with tasks to perform. VR devices expand the dimension of interaction points in that environment. The latest motion capture device, like Sony’s Mocopi [1], can capture and operate a 3d avatar in a VR environment using real-world physical movements of human limbs and tracking and translating them in real-time with a minimal setup footprint. The state of current VR input devices’ tracking implications is immense and can reduce the barrier to longterm VR usability. At the same time, people are concerned about these tracked datasets, which run the risk of violating user privacy in different ways of inferencing [2][3]; physical harms [4], and manipulation and violation of immersive experiences [5] [6].

In the event of a VR system security flaw, it is possible to exploit VR usability data to produce malware for users, putting them at serious risk [7]. Imposing the control point to the data flow through VR technology has become vital as the technology space has evolved at a breakneck rate. While engaging in various interesting VR activities, a well-known platform called Horizon Worlds by Meta actively records user behavioral data, including audio logs, as part of their data retention policy. However, it is known as ‘doxing’ when information from social media networking sites is exploited to reveal users’ private lives. One may utilize the Metaverse to gain access to more private information about a person, like their habits and physical traits [8]. The sections [3] and [4] of this article try to address with a demonstration why the significance of security in VR should be elevated.

2 BACKGROUND

Access to personalized information about a user can be used against them to alter how they interact with any information resource. Typically, the information saved about a user is referred to as a user model or profile. An established area of artificial intelligence research is user modeling. Many adaptive or personalized systems have an embedded user model that is the basis for features like customized recommendations. This strategy, which has several limitations, has been noted to require the application developer to create and maintain their own user model. Because of these limitations, Fortnite [9], a popular video game, took

advantage of a privacy loophole and used digital patterns to draw information from kids under 13 years old without obtaining the consent of their parents. The parent company, Epic Games, went through a settlement with Federal Trade Commission for a privacy violation[10].

According to Kanoje et al., user profiling is the practice of locating information about a user’s realm of interest. The system can use this data to learn more about the user and utilize this understanding to improve retrieval so that the user is satisfied [11]. In another article on user profiling by Farid et al. [12], the creation of an initial user profile for a new user and the ongoing updating of the profile information to accommodate the ongoing changes in the user’s interests, preferences, and needs are the two ways used in the user modeling process. Creating a user profile is a significant difficulty in user profiling to represent user preferences correctly. But this data is being studied even though privacy is violated. So to learn more about user profiling, we considered a test case to identify a few of the hidden dimensions potentially exploitative in nature.

Features	Definition
Distance traveled	It is the total length of the path traveled between two positions.
Coverage	Total number of unit cubes covered (area).
Number of decision points reached	Total number of decision points covered in the maze.
Positional Curvature	The signed angle of curvature between two consecutive position vectors.
Head rotation amount	The unsigned head rotation angle between two consecutive rotation transforms.

Table 1: Features extracted from users’ trajectory data for deep exploration and their corresponding definitions.

3 TEST CASE SCENARIO : A SINGLE-LEVEL MAZE

A simple (single level) 3d maze was designed to observe navigability of the subjects while a set of empirical data were collected such as, trajectory data, head rotation, and body rotation [Figure 1]. The maze experience was deployed as a 2x2 study design. A 2x2 factorial design is an experimental design that allows researchers to understand the effects of two independent variables (each with two levels) on a single dependent variable.

4 MEASURES

To conduct a thorough analysis of the trajectory data, we defined a set of mathematically derived features that were generalized for each trajectory. These features included the distance traveled, the number of decision points (nodes) reached inside the maze, the amount of head rotation, the positional curvature, and the maze coverage. Some of these trajectory features are illustrated in Table 1. Positional curvature feature refers to the curvature of the trajectory calculated per frame between successive position vectors. Rotation amount feature refers to the unsigned angle calculated per frame between successive head rotation transforms stored as Quaternions. Coverage feature is simply the number of unit cubes covered (area) by the user, calculated per frame. We used R and SPSS together to conduct the analysis of the trajectory data.

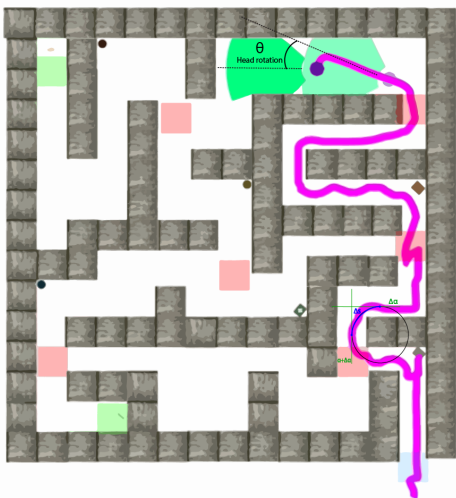

Figure 1: Single level maze study - Visualization of two trajectory features: positional curvature and head rotation amount.

5 MACHINE LEARNING APPROACH TO PRIVACY - AN LSTM FRAMEWORK

Deep learning is a dynamic tool to manipulate through data. Creating models in Deep Learning (DL) with Recurrent Neural Networks (RNN) would be one of the best fits with sequential data. In a maze-solving gaming paradigm, people generally tend to use previous memories to make instantaneous spatial decisions. Both Video gamers and non-video gamers tend to solve virtual mazes with previous information they have. Like if someone enters a dead end, they may try to remember their

previous turns in the maze and get back to a point from where they can take another turn while avoiding the dead end. The strategy lies in the methodology of having memories of different states at different time periods. Long Short-Time Memory (LSTM) mimics a similar framework of reasoning. LSTM is a special type of RNN that traditionally contains cycles that feed the network activation from a previous time step as inputs to influence predictions at the current one[13]. The output of an LSTM network depends on the type of data. Depending on the problem, the output of each time step will have a different depiction. In robotics, the LSTM network has been implemented to demonstrate complex data and was able to verify the pattern of variable motion, which is analogous to human motion. The challenges of predicting human actions or the high degrees of freedom (DOF) human motions include inaccuracy and imperfections when they are estimated from real-time sequences[14]. LSTM leverages the crucial ability to understand the context of sequential data. Independent of data size, LSTM can evaluate the prediction by learning to update and estimate the relative weights that represent the internal states through replication of its layers[15]. Conventional RNNs have limited contextual information as the recurrent connections cause the input's influence to change exponentially, referred to as *the vanishing gradient problem*. The LSTM type RNN is also no different in this regard, but a self-connected layer consisting of sub-networks with multiple internal cells leverages to get out of this problem. Multiplicative gates ease the way of storing and accessing information over long periods of time. This type of network helps to create an algorithm to take decisions either as a part of the instantaneous memory that should be removed or carried further during processing the sequential data[16].

LSTMs can learn through data over a time period (much like the human brain) by controlling these gates, namely the input gate, forget gate, and output gate. These gates work as the write, read and reset of the memory cells. Memory cells are interconnected in an LSTM network in such a way that the output of one state can work as an input for the next cell. A schematic architecture of the LSTM network can be seen in Figure 2. This simplistic schematic shows, t -th cell of the LSTM network, which receives the previous cell state C_{t-1} representing the information being possessed so far until the previous $(t-1)$ -th step. Each LSTM cell receives input x_t as the t -th sample of a sequence along with previous states' output h_{t-1} and processes an output value h_t and updated cell state C_t . Gates of this LSTM network allow to make correlations during calculation and help information to be 'forgotten' or 'propagated' into the next cells [15].

An input gate i_t and output gate o_t control the input and output information respectively:

$$i_t = \sigma(W_i \cdot [h_{t-1}, x_t] + b_i); [\text{input gate}]$$

$$o_t = \sigma(W_o \cdot [h_{t-1}, x_t] + b_o); [\text{output gate}]$$

W and b represent the weights and biases of the parameters, through which the information flow is controlled.

New t -th values will be updated using these equations:

$$C_t = f_t * C_{t-1} + i_t * C_{t^*}$$

C_{t^*} = computed state from the current step x_t and previous output h_{t-1}

$$C_{t^*} = \tanh(W_C \cdot [h_t, x_t] + b_C)$$

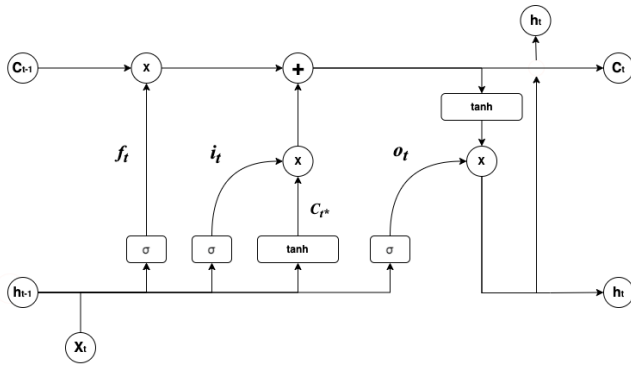

Figure 2: Schematic of LSTM single cell. C_{t-1} represents the previous $t - 1$ -th step Cell State, h_{t-1} the output of previous $t - 1$ -th step. x_t is the t -th sample of the sequence, C_t and h_t are updated cell state and output respectively. i_t , o_t, f_t represents input, output, and forget gate respectively[17].

The final output value of a step is represented by this equation:

$$h_t = o_t * \tanh(C_t)$$

The forget gate f_t helps the network to forget information that is no longer necessary:

$$f_t = \sigma(W_f \cdot [h_{t-1}, x_t] + b_f)$$

6 PRIVACY RISKS

The usability of VR can broaden the capabilities for various activities; however, it also increases the potential for risks[18]. Risk management in VR still lacks the user’s trust in different perspectives such as privacy, security, well-being, etc. [5]. Similar concerns are being explored in the field of AR [19]. The question of privacy and security measures has still been left unanswered, nonetheless. All classes of users (including gamers and non-gamers) who opt to get an engaging experience using VR and AR platforms might have no idea about the amount of information they are giving away. Information gathered through VR or AR is a potential resource for imitating motor, visual or emotional patterns toward specific tasks. For instance, an individual can employ the deep face verification procedure without the assistance of a trained artificial intelligence model by using actual data obtained from a person’s VR experience[20].

The industry has started using ‘Synthetic Data’, which can be produced using simplified data, which is not actual data. However, it can still produce mathematical patterns that are similar to those of real data[21]. Synthetic data’s purpose is to safeguard privacy, but it can also be employed for other purposes. One of the most powerful tools available today, machine learning, can readily extract very accurate projected data from this type of input. Apple Inc. verifies FaceID using TrueDepth. To unlock a phone, TrueDepth employs attention-aware technology[22]. FaceID detects information when someone looks at the smartphone with their eyes open and their attention focused there. As a result, it is more challenging for someone to unlock another device without permission. However, if any information is utilized to mimic that attention pattern, it may be possible to unlock it

using that knowledge. This will probably be the case in the long run. Similarly, the test case of an immersive maze-solving video game can serve enough data to predict future steps with viable efficiency.

Numerous strategies are being suggested to mitigate privacy problems in the Metaverse. The user can create an addition to the clone of his avatar, allowing him to displace and change his appearance. An avatar can teleport to generate many copies of themselves that can be used to block tracking. Smart contracts should be built with countermeasures to companies trying to track users unethically.

Video game profiling is being researched to improve player performance and gaming experience. However, the gamer’s privacy may be compromised if their gaming profile makes some internal information public [23]. The viewpoint of game developers may be more favorable, but if exploited, it could be worse.

7 FUTURE WORK

Privacy on the internet is already a significant concern and is not being adequately addressed [24]; moreover, security concerns regarding VR applications have increased considerably. Spending a few hours in VR environments can provide developers with training data to create algorithms for pairing body attributes with subsequent behavior. The code of ethics can be modified for VR[5], or users’ permissions can be increased regarding sharing the data, but still, algorithms need to be implemented more generically. As stated earlier, ML is a powerful technology that can be applied to create algorithms in a preferred manner. ML should operate delicately, possibly separating the exploitative data from the usability data. Once ML has identified a pattern in the derived data, it can ask the users for permission to maintain or delete the pattern. It is equivalent to asking for consent before any medical procedure, regardless of the patient’s desire to donate their body parts after death.

8 CONCLUSIONS

Many of the problems smartphones have are now passed onto AR/VR wearables intended for common users. One of the key issues these gadgets have in common is the ease with which they can take images, record videos, and track other potential usability data without proper vetting. The advent of smartphone cameras raised worries about third parties involved in the process, and there have been privacy worries about how simple it is to film bystanders. Due to the novelty of VR/AR display devices and the general lack of a standard of ethics-based practices, it is imperative that ML-driven approaches become sensitive to usability data to further reinforce trust and promote healthy usage of the technology.

REFERENCES

- [1] Steve Dent. Sony steps into the metaverse with the ‘mocopi’ motion tracking system. <https://tinyurl.com/5n6pb233>, 2022.
- [2] Fiachra O’Brocháin, Tim Jacquemard, David Monaghan, Noel O’Connor, Peter Novitzky, and Bert Gordijn. The

- convergence of virtual reality and social networks: threats to privacy and autonomy. *Science and engineering ethics*, 22:1–29, 2016.
- [3] Franziska Roesner, Tadayoshi Kohno, and David Molnar. Security and privacy for augmented reality systems. *Commun. ACM*, 57(4):88–96, apr 2014. ISSN 0001-0782. doi: 10.1145/2580723.2580730. URL <https://doi.org/10.1145/2580723.2580730>.
- [4] Sue Valerie Gray Cobb, Sarah Nichols, Amanda Ramsey, and John R. Wilson. Virtual reality-induced symptoms and effects (vrise). *Presence: Teleoperators & Virtual Environments*, 8:169–186, 1999.
- [5] Devon Adams, Alseny Bah, Catherine Barwulor, Nureli Musabay, Kadeem Pitkin, and Elissa M. Redmiles. Ethics emerging: The story of privacy and security perceptions in virtual reality. In *Proceedings of the Fourteenth USENIX Conference on Usable Privacy and Security*, SOUPS '18, page 443–458, USA, 2018. USENIX Association. ISBN 9781931971454.
- [6] Orin S. Kerr. Criminal law in virtual worlds. *Cyberspace Law eJournal*, 2008.
- [7] Store Help Center. Meta horizon worlds frequently asked questions : Are you recording what’s happening in meta horizon worlds?
- [8] Pinar Kürtünlüoğlu, Beste Akdik, and Enis Karaarslan. Security of virtual reality authentication methods in meta-verse: An overview. *arXiv preprint arXiv:2209.06447*, 2022.
- [9] Wikipedia. Fortnite. <https://en.wikipedia.org/wiki/Fortnite>, 2023.
- [10] BloombergLaw. Fortnite lawsuit ftc. <https://tinyurl.com/bdds25ye>, 2022.
- [11] Sumitkumar Kanoje, Sheetal Girase, and Debajyoti Mukhopadhyay. User profiling trends, techniques and applications. *arXiv preprint arXiv:1503.07474*, 2015.
- [12] Marina Farid, Rania Elgohary, Ibrahim Moawad, and Mohamed Roushdy. User profiling approaches, modeling, and personalization. In *Proceedings of the 11th International Conference on Informatics & Systems (INFOS 2018)*, 2018.
- [13] Marleen C. Tjepkema-Cloostermans, Rafael C.V. de Carvalho, and Michel J.A.M. van Putten. Deep learning for detection of focal epileptiform discharges from scalp eeg recordings. *Clinical Neurophysiology*, 129(10):2191–2196, 2018. ISSN 1388-2457. doi: <https://doi.org/10.1016/j.clinph.2018.06.024>. URL <https://www.sciencedirect.com/science/article/pii/S1388245718311465>.
- [14] Jae Sung Park, Chonhyon Park, and Dinesh Manocha. I-planner: Intention-aware motion planning using learning-based human motion prediction. *The International Journal of Robotics Research*, 38(1):23–39, 2019. doi: 10.1177/0278364918812981. URL <https://doi.org/10.1177/0278364918812981>.
- [15] Ian Goodfellow, Yoshua Bengio, and Aaron Courville. *Deep learning*. MIT press, 2016.
- [16] Rafael Rêgo Drumond, Bruno Augusto Dorta Marques, Cristina Nader Vasconcelos, and Esteban Walter Gonzalez Clua. Peek - an lstm recurrent network for motion classification from sparse data. In *VISIGRAPP*, 2018.
- [17] Christopher Olah. Understanding lstm networks, 2015. URL <http://colah.github.io/posts/2015-08-Understanding-LSTMs/>.
- [18] Ian. Warren, Darren. Palmer, and Australian Institute of Criminology. *Crime risks of three-dimensional virtual environments / Ian Warren and Darren Palmer*. Australian Institute of Criminology Canberra, A.C.T, 2010.
- [19] Tamara Denning, Zakariya Dehlawi, and Tadayoshi Kohno. In situ with bystanders of augmented reality glasses: Perspectives on recording and privacy-mediating technologies. In *Proceedings of the SIGCHI Conference on Human Factors in Computing Systems*, CHI '14, page 2377–2386, New York, NY, USA, 2014. Association for Computing Machinery. ISBN 9781450324731. doi: 10.1145/2556288.2557352. URL <https://doi.org/10.1145/2556288.2557352>.
- [20] Yaniv Taigman, Ming Yang, Marc’ Aurelio Ranzato, and Lior Wolf. Deepface: Closing the gap to human-level performance in face verification. In *2014 IEEE Conference on Computer Vision and Pattern Recognition*, pages 1701–1708, 2014. doi: 10.1109/CVPR.2014.220.
- [21] Brian Eastwood. What is synthetic data — and how can it help you competitively? <https://tinyurl.com/55k8ekwe>, 2023.
- [22] Apple. About face id advanced technology. <https://support.apple.com/en-us/HT208108>, 2022.
- [23] Emmanuel Guardiola and Stephane Natkin. *A Game Design Methodology for Generating a Psychological Profile of Players*, pages 363–380. Springer International Publishing, Cham, 2015. ISBN 978-3-319-05834-4. doi: 10.1007/978-3-319-05834-4_16. URL https://doi.org/10.1007/978-3-319-05834-4_16.
- [24] Annie I. Anton, Julia B. Earp, and Jessica D. Young. How internet users’ privacy concerns have evolved since 2002. *IEEE Security & Privacy*, 8(1):21–27, 2010. doi: 10.1109/MSP.2010.38.