

Program Dependence Net and Its Slice for Verifying Linear Temporal Properties

Zhijun Ding, Shuo Li, Cheng Chen and Cong He

Department of Computer Science and Technology, Tongji University, 201804, Shanghai, China.

Abstract

The finite-state model checking of software is still limited by the notorious state-explosion problem. The dependence-based program slicing is effective to reduce the verification time and is orthogonal to other reduction techniques of model checking. However, within slicing concurrent programs for model checking, the conversions between multiple irreplaceable models and the calculation of dependencies for some variables irrelevant to the verified property produce redundant calculating costs. Thus, we propose a Program Dependence Net (PDNet) as a unified model combining the control-flow structure with dependencies to avoid the model conversions. For reduction, we propose a PDNet slicing to capture the relevant variables' dependencies on demand. The calculating costs could be significantly compressed by our unified model and on-demand slicing based on PDNet. Then, we implemented a concurrent program model checking tool based on PDNet and its slice. Finally, we validated the advantages of our methods.

Keywords: Petri nets, Slice, PThread, Linear Temporal Logic, Verification

1 Introduction

Verifying the linear temporal logic (LTL) is a challenging problem, especially for the concurrent system or software. Thanks to the high degree of automation, the finite-state model checking [1] as an algorithmic technique is widely applied for verifying the linear temporal properties of the concurrent systems. However, the major obstacle to its practical application is the notorious state-explosion problem [1]. There has been many researches on the reduction

techniques alleviating this problem for the concurrent software, e.g., partial order [2], suggested from the state-space perspective. For instance, partial order methods could reduce possible orderings (interleavings) of statements from the independent threads. However, they don't guarantee that all parts irrelevant to the verified property shall be reduced.

Differently, program slicing [3] could precisely calculate the relevant portions concerning the criterion to capture all information relevant to the verified property (as the slicing criterion). So far, the property-directed static backward slicing methods as a reduction technique has been widely applied in (but not limited to) software verification [4, 5]. The existing evaluations [6–8] have confirmed that the slicing methods could be effective to reduce the verification time and be orthogonal to other reduction techniques of model checking. Traditionally, program slicing first builds a program dependence graph (PDG) [9–11] based on a control-flow graph (CFG). The nodes of a PDG correspond to the statements, and the edges capture the dependencies among these statements. Moreover, the dependencies as the edges of the PDG could be divided into control-flow dependencies and data-flow dependencies. The control-flow dependencies captured from the CFG identify the conditions that dominate the execution of statements, and the data-flow dependencies are captured from the reachable definition-use relation for the variables on the CFG's nodes. Then, the transitive closure along the PDG's edges starting from the nodes of slicing criterion identifies the remained nodes. The residual program (i.e., the program slice) consists of the statements corresponding to these remained nodes. As we have yet seen, the dependence-based program slicing has been used as a preprocessing step [12–14] of model checking. Hence, the control-flow automata (CFAs) as the formal model could represent the residual program by describing its control-flow structure (i.e., the execution orders between statements) in most mature software model checking tools [15]. The nodes of a CFA correspond to the control points, and the edges correspond to the program operations [16]. Edges between two nodes are labeled by an executed operation when a control point moves from the source to the destination. Finally, a reachable tree [16] of the CFA identifies the state-space for model checking.

Among the above methods, there are two shortcomings in calculating costs. (1) There are multiple irreplaceable models (e.g., PDG for slicing and CFA for model checking) during the whole process, causing the model conversions between these models. However, a unified model could save the calculating costs of the model conversions from the PDG to the CFA. (2) All data-flow dependencies are captured in full to calculate a PDG. Actually, there exist data-flow dependencies of some variables irrelevant to the verified property in the PDG. However, the calculating costs of these data-flow dependencies can be saved based on such a unified model. To address the above two shortcomings, we intend to propose a unified model combining the control-flow structure with the program dependencies and enable the unified model to calculate the data-flow dependencies on demand during slicing, instead of capturing them completely in advance. However, it's challenging to propose such a unified

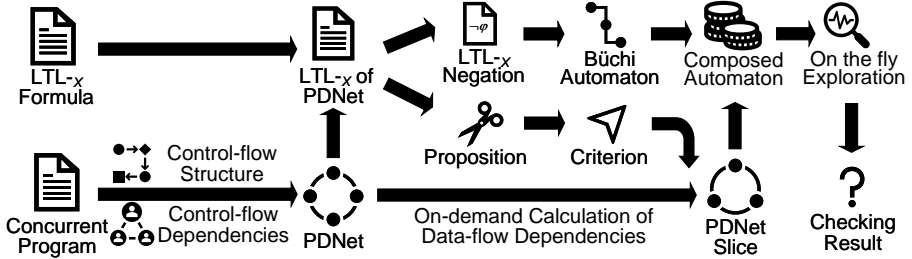

Fig. 1: Overview of our methods

model based on CFA. As mentioned above, the edges of CFA represent the executed operations (statements), but the edges of PDG represent the dependencies between statements, implying their edges are irreplaceable. Therefore, it's challenging to combine the edges of CFA with the edges of PDG directly, and then to calculate the data-flow dependencies on demand based on CFA.

As we have known, Petri nets (PNs) [17, 18] as a concurrency model can represent a concurrent program's control-flow structure, and then apply the automata-theoretic [19] approach for LTL model checking. Intuitively, the source of an edge in CFA is only one, but the input place of a transition in PN is no longer limited to one. Then, whether a statement gets the execution order condition from the control-flow structure and the domination condition from the control-flow dependencies could be represented by different input places of the transition corresponding to this statement. Thus, PNs could provide an appropriate description to combine the control-flow structure with the control-flow dependencies. Furthermore, the reachable definition-use relations for the variables of statements can be captured for the data-flow dependencies by the variable operations as well as the control-flow structure. In fact, colored Petri nets (CPNs) [20] as a kind of high-level PN could describe the variable operations by the colored places and expressions. Thus, PNs could also provide an on-demand capturing data-flow dependencies ability.

However, the existing methods based on PNs or CPNs [21–23] don't combine the control-flow structure with the control-flow dependencies. Hence, we propose Program Dependence Net (PDNet) based on CPNs as a unified model to benefit against the calculating costs of the model conversions. Based on our PDNet, we propose on-demand slicing of PDNet to benefit against the calculating costs of the data-flow dependencies of the irrelevant variables.

The overview of our method is shown in Fig. 1. We firstly construct the PDNet combining the control-flow structure with the control-flow dependencies of a concurrent program, and then slice this PDNet for the given LTL-X formula with the on-demand calculation of the data-flow dependencies. At the same time, the propositions in the original LTL-X formula of program are transformed into the corresponding form of PDNet automatically. LTL-X formulae specify multiple forms of linear temporal properties, e.g., assertion violation, error location reachability. Then, the state-space generated from the

PDNet slice is composed with the Büchi automaton of the LTL- X negation. Finally, whether the concurrent program satisfies the LTL- X property is confirmed through the on-the-fly exploration of the composed automaton [24]. The main contributions of this paper are summarized as follows:

1. We propose PDNet as the unified model to represent the concurrent programs. PDNet could combine the control-flow structure with the control-flow dependencies, avoiding the calculating costs of the model conversions.
2. We propose an on-demand slicing method to reduce PDNet, whose criterion is extracted from the LTL- X formulae. The core of our slicing is that the data-flow dependencies are captured on demand based on the unified model PDNet, avoiding the redundant calculating costs.
3. We implement a concurrent program model checking tool named *DAMER* (Dependence Analyzer and Multi-threaded programs checkER) based on PDNet and its slice. It translates the input programs to a PDNet without any manual intervention and reduces PDNet by the on-demand slicing automatically. The experiments evaluate the advantages of our methods.

We introduce a motivating example for illustrating the contributions in section 2. Then we define PDNet for verifying linear temporal properties in section 3. PDNet modeling for concurrent programs in section 4 and PDNet slicing for reduction in section 5 are proposed. In section 6, we implement a prototype tool and carry out experiments. Finally, we summarize this paper.

2 Motivating Example

In this paper, we address the LTL verification problem of concurrent programs using POSIX threads [25]. Here, a concurrent program with an error location in line 9 is an example program in Fig. 2(a). An LTL- X formula $\mathcal{G} \neg error()$ expresses the safety property of this program, which means *error()* doesn't execute in every state of every path. The CFA [15] in Fig. 2(b) represents the control-flow structure of the program. The nodes identify the locations expressed as circles with integers (corresponding to the integers in Fig. 2(a)), and the edges identify the statements expressed as arrows. For instance, the node labelled by 9 corresponds to line 9 of the program, and the edge from 9 to 10 corresponds to *error()*. The PDG [12] is in Fig. 2(c). For control-flow dependencies (expressed as dotted arrows), $x=1$, $y=3$ and $z=y+2$ all depend on the entry of *thr1*, *error()* depends on the condition *if*($x<1$), and *if*($x<1$) depends on the entry of *thr2*. For data-flow dependencies (expressed as bolded arrows), *if*($x<1$) of *thr2* depends on $x=1$ of *thr1* because $x<1$ references x defined in $x=1$ and they belong to different concurrent executing threads, and $z=y+2$ depends on $y=3$ of *thr1* because $z=y+2$ references y defined in $y=3$ and $z=y+2$ is reachable from $y=3$. The criterion for $\mathcal{G} \neg error()$ is the bolded node, and the remained nodes are filled with light gray in Fig. 2(c). Thus, $y=3$ and $z=y+2$ are sliced away.

The traditional CPN model [21] of the program is in Fig. 2(d) (The labels on all arcs are omitted for simplicity). Here, each transition can simulate

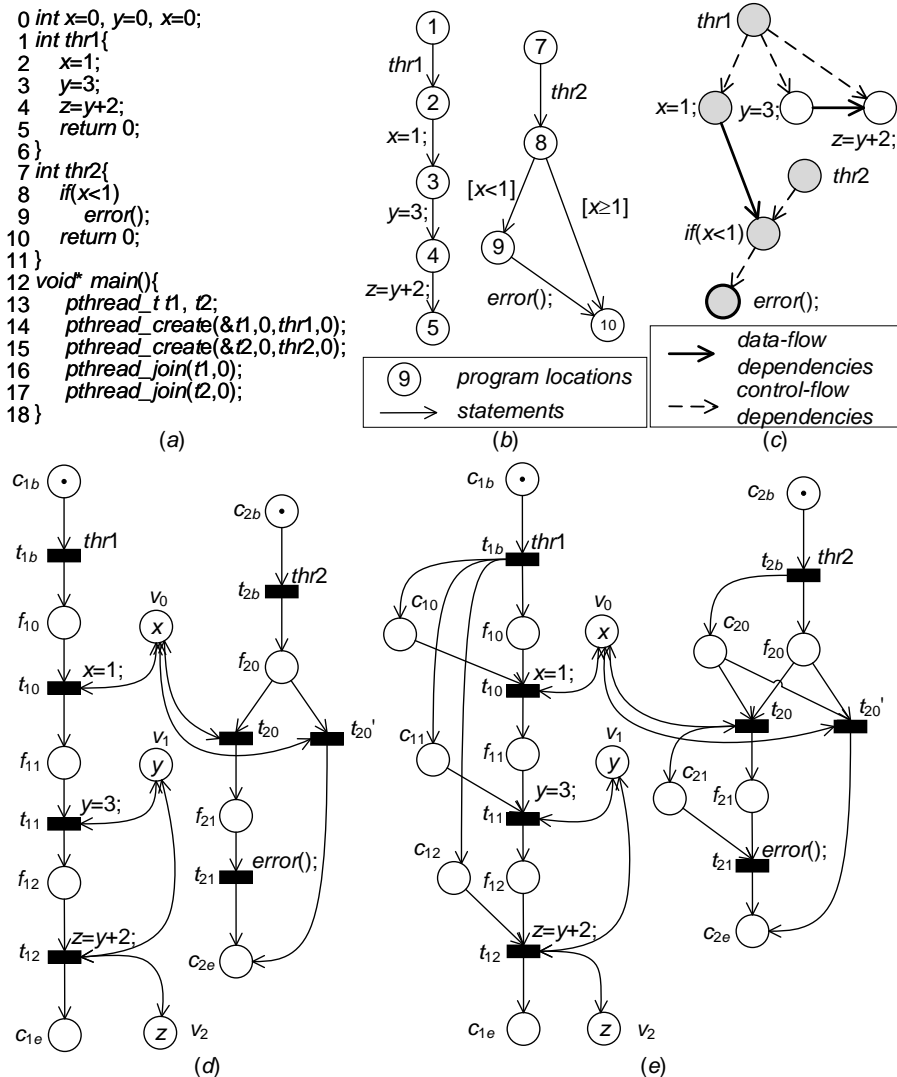

Fig. 2: Motivating example for the unified model (a) A concurrent program with POSIX threads to check an error location (b) The CFA of this program (c) The PDG of this program (d) A CPN converted from this program (e) A PDNet converted from this program

a statement execution through its occurrence. The corresponding transition occurrences can operate the variables represented by places. For instance, t_{11} ($y=3$) shall be enabled after the occurrence of t_{10} ($x=1$). And x shall be assigned to 1 when t_{10} occurs. However, this model only represents the control-flow structure, and the dependencies aren't represented in this model. To integrate the control-flow structure and the control-flow dependencies to

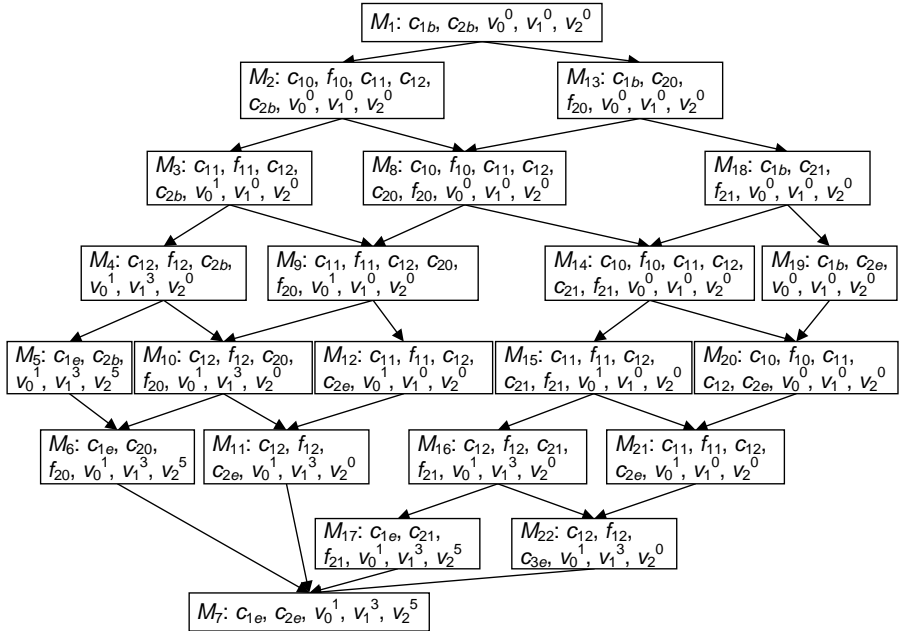

Fig. 3: The state-space of the PDNet in Fig. 2(e)

a unified model, we design specific places and arcs for a transition of PDNet in Fig. 2(e) (The labels on all arcs are omitted for simplicity) to distinguish the execution order condition and domination condition of a statement. The execution order condition reflects the actual execution syntax and semantics in the control-flow structure, and the domination condition (e.g., the dependencies between a branching condition and its body statements) reflects the control-flow dependencies. For instance, f_{11} , (t_{10}, f_{11}) and (f_{11}, t_{11}) characterize the fact that $y=3$ executes after $x=1$. And c_{11} , (t_{1b}, c_{11}) and (c_{11}, t_{11}) characterize the fact that $y=3$ depends on the entry of $thr1$.

Then, the marking graph of this PDNet represents the state-space in Fig. 3. The nodes identify the markings expressed as rectangles with place names, and the edges identify the marking transitions corresponding to the transition occurrence of PDNet expressed by arrows. (The transition labels on all arrows are also omitted for simplicity). Here, the markings are represented by the places marked by tokens currently. For instance, M_7 is a marking, where places c_{1e} , c_{2e} , v_0 , v_1 and v_2 are marked by tokens. (M_6, M_7) is a marking transition by occurring transition t_{20} . Particularly, the superscripts of places v_0 , v_1 and v_2 indicate the value of the variables in this marking. For instance, the symbol v_0^1 in M_7 represents the value of x is 1.

Moreover, the data-flow dependencies for the irrelevant variables bring redundant calculating costs. For instance, the data-flow dependencies relevant to y are captured in the PDG of Fig. 2(c), but the edges of these data-flow

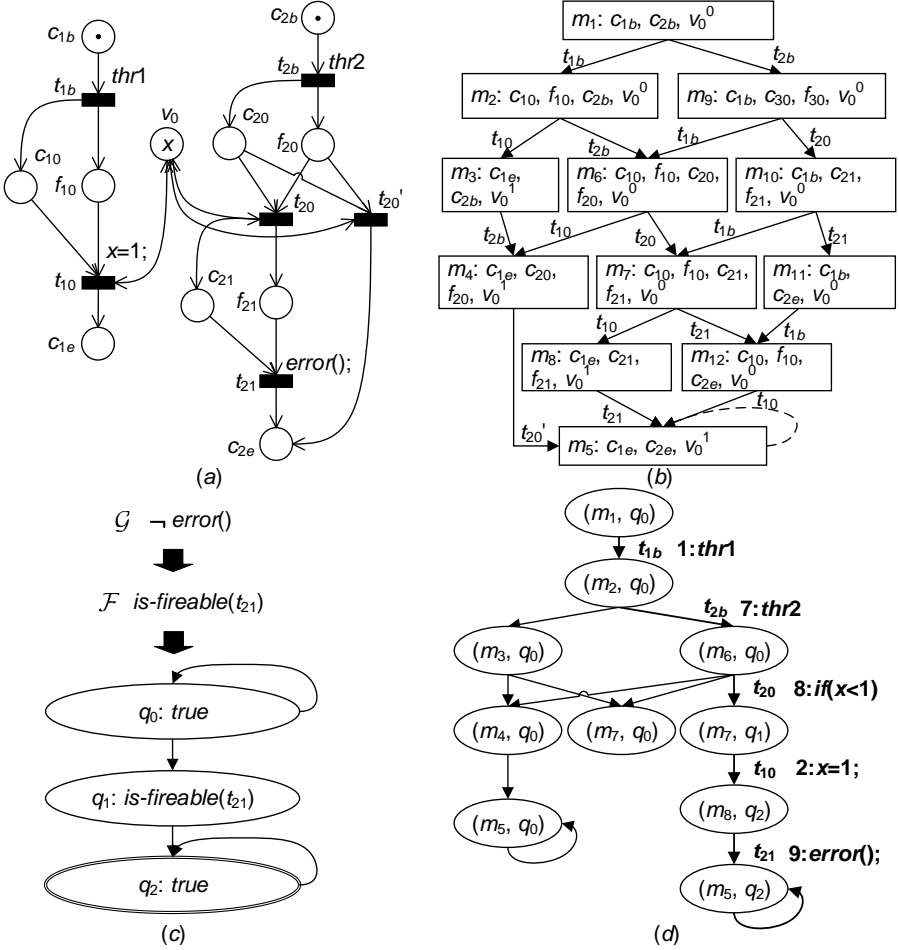

Fig. 4: Motivating example for on-demand slicing (a) The PDNet slice for $\mathcal{G} \neg \text{error}()$ (b) The state-space of the PDNet slice (c) The Büchi automaton for the negation of $\mathcal{G} \neg \text{error}()$ (d) The explored composed automaton of PDNet slice for $\mathcal{G} \neg \text{error}()$

dependencies aren't remained in the slice. Differently, the data-flow dependencies could be captured only when the relevant variable is confirmed not to be sliced. To benefit against the costs, we propose the PDNet slicing to capture the data-flow dependencies on demand. Based on our on-demand PDNet slicing method, the data-flow dependencies of x are captured when x is added in the PDNet slice in Fig. 4(a). Obviously, $c_{11}, f_{11}, t_{11}, c_{12}, f_{12}, t_{12}, v_1, v_2$ are reduced compared with the PDNet in Fig. 2(e), meaning $y=3$ and $z=y+2$ are sliced away. Then, its state-space (i.e., the marking graph of PDNet slice) is shown in Fig. 4(b). Here, a transition labeled to the edge indicates this transition occurrence to give rise to the marking transition. For instance, $m_7 \xrightarrow{t_{10}} m_8$

is a marking transition from m_7 to m_8 by occurring t_{10} . Thus, 10 states are reduced by PDNet slicing compared with the state-space of the PDNet in Fig. 3. Moreover, an arc of M_5 pointing to itself is added as a dotted arrow because the LTL- X model checking is based on the infinite path [19].

For the LTL- X formula $\mathcal{G} \neg error()$ to specify the safety property of the example program, $error()$ is firstly translated to $is - fireable(t_{21})$ of the PDNet. If a marking enabling the transition t_{21} , this proposition is *true* in the marking. For example, transition t_{21} is enabled under the marking m_{10} of Fig. 4(b), and $is - fireable(t_{21})$ is *true* in m_{10} . Then, the formula is translated to its negation form $\mathcal{F} is - fireable(t_{21})$, which is further translated to a Büchi automaton [26] shown in Fig. 4(c). There are three states in the Büchi automaton, where *true* means that the nodes q_0 and q_2 can be synchronizing with any reachable markings. And q_1 labelled by $is - fireable(t_{21})$ can only be synchronizing with the reachable markings enabling t_{21} in Fig. 4(b). Finally, only 10 composed states are explored in Fig. 4(d) for the first counterexample with on-the-fly way [24]. For instance, (m_7, q_1) is a composed state synchronizing a marking m_7 in Fig. 4(b) and a state q_1 in Fig. 4(c) because t_{21} is enabled in m_7 . As a result, the example program in Fig. 2(a) violates the safety property $\mathcal{G} \neg error()$, and the statement execution 1, 7, 8, 2, 9 corresponding to the occurrence sequence $t_{1b}, t_{2b}, t_{20}, t_{10}, t_{21}$ identified by the marking sequence $m_1, m_2, m_6, m_7, m_8, m_5, \dots$ of Fig. 4(d) is a counterexample.

3 PDNet for Verifying Linear Temporal Logic

3.1 Program Dependence Net

To define our PDNet (Program Dependence Net) based on CPN, we give the definitions of multiset and CPNs [20] firstly.

Definition 1 (Multiset) Let S be a non-empty set. A multiset ms over S is a function $ms: S \rightarrow \mathbb{N}$ that maps each element into a non-negative integer. S_{MS} is the set of all multisets over S . We use $+$ and $-$ for the sum and difference of two multisets. And $=, <, >, \leq, \geq$ are comparisons of multisets, which are defined in the standard way.

We give some symbolic terms for the following definitions. $BOOL = \{false, true\}$ is the set of Boolean predicates with standard logic operations. $EXPR$ is a set of expressions. $Type[e]$ is the type of expression $e \in EXPR$, i.e., the types of the values obtained when evaluating e . $Var(e)$ is the set of all variables in an expression e . $EXPR_V$ for a variable set V is the set of expressions $e \in EXPR$ such that $Var(e) \subseteq V$. $Type[v]$ is the type of variable v . CON is the set of constants, and $Type[o]$ is the type of constant o .

Definition 2 (Colored Petri Nets) CPN is defined by a 9-tuple $N ::= (\Sigma, V, P, T, F, C, G, E, I)$, where:

1. Σ is a finite non-empty set of types, called color sets.

2. V is a finite set of the typed variables. $\forall v \in V: \text{Type}[v] \in \Sigma$.
3. P is a finite set of places.
4. T is a finite set of transitions and $T \cap P = \emptyset$.
5. $F \subseteq (P \times T) \cup (T \times P)$ is a finite set of directed arcs.
6. $C: P \rightarrow \Sigma$ is a color set function that assigns a color set $C(p)$ belonging to the set of types Σ to each place p .
7. $G: T \rightarrow \text{EXPR}_V$ is a guard function, that assigns an expression $G(t)$ to each transition t . $\forall t \in T: (\text{Type}[G(t)] \in \text{BOOL}) \wedge (\text{Type}[\text{Var}(G(t))] \subseteq \Sigma)$.
8. $E: F \rightarrow \text{EXPR}_V$ is a function, that assigns an arc expression $E(f)$ to each arc f . $\forall f \in F: (\text{Type}[E(f)] = C(p(f))_{MS}) \wedge (\text{Type}[\text{Var}(E(f))] \subseteq \Sigma)$, where $p(f)$ is the place connected to arc f .
9. $I: P \rightarrow \text{EXPR}_\emptyset$ is an initialization function, that assigns an initialization expression $I(p)$ to each place p . $\forall p \in P: (\text{Type}[I(p)] = C(p)_{MS}) \wedge (\text{Var}(I(p)) = \emptyset)$.

Remark 1 PDNet is also a 9-tuple, and it differs from CPNs as the following aspects:

(1) We divide P into three subsets, i.e., $P = P_c \cup P_v \cup P_f$. Concretely, P_c is a subset of control places, P_v is a subset of variable places, and P_f is a subset of execution places.

(2) We divide F into three subsets, i.e., $F = F_c \cup F_{rw} \cup F_f$. Concretely, $F_c \subseteq (P_c \times T) \cup (T \times P_c)$ is a subset of control arcs, $F_{rw} \subseteq (P_v \times T) \cup (T \times P_v)$ is a subset of read-write arcs, and $F_f \subseteq (P_f \times T) \cup (T \times P_f)$ is a subset of execution arcs.

In addition to the above differences, other definitions and constraints of PDNet are consistent with CPNs. As the example in Fig. 4(a), $P_v = \{v_0\}$ where v_0 is a variable place corresponding to the variable x , $P_c = \{c_{1b}, c_{2b}, c_{1e}, c_{2e}, c_{10}, c_{20}, c_{21}\}$, $P_f = \{c_{1b}, c_{2b}, c_{1e}, c_{2e}, f_{10}, f_{20}, f_{21}\}$, and t_{21} corresponds to the statement *error()*.

For a node $x \in P \cup T$, its preset $\bullet x = \{y | (y, x) \in F\}$ and its postset $x \bullet = \{y | (x, y) \in F\}$ are two subsets of $P \cup T$. For instance, $\bullet t_{21} = \{f_{21}, c_{21}\}$, $t_{21} \bullet = \{c_{2e}\}$, and $\bullet v_0 = v_0 \bullet = \{t_{10}, t_{20}, t'_{20}\}$ in Fig. 4(a). Then, some basic concepts of PDNet are defined.

Definition 3 (Basic Concepts of PDNet) Let N be a PDNet.

1. $M: P \rightarrow \text{EXPR}_\emptyset$ is a marking function that assigns an expression $M(p)$ to each place p . $\forall p \in P: \text{Type}[M(p)] = C(p)_{MS} \wedge (\text{Var}(M(p)) = \emptyset)$. For convenience, a marking of N is denoted by M or M with a subscript. In particular, M_0 represents the initial marking by $\forall p \in P: M_0(p) = I(p)$.

2. $\text{Var}(t) \subseteq V$ is the variable set of a transition t . It consists of the variables appearing in expression $G(t)$ and in arc expressions of all arcs connected to the transition t .

3. $B: V \rightarrow \text{CON}$ is a binding function that assigns a constant value $B(v)$ to each variable v . In particular, $B[t]$ is the set of all bindings for a transition t , that maps $v \in \text{Var}(t)$ to a constant value. And $b \in B[t]$ is a binding of a transition t .

4. A binding element (t, b) is a pair where $t \in T$ and $b \in B[t]$. $BE(t)$ is a set of all binding elements of a transition t .

The enabled and occurrence rules as well as the occurrence sequence of PDNet are defined by evaluating the guard expressions and arc expressions. Formally, $e\langle b \rangle$ represents the evaluating result of the expression e in the binding b by assign a constant from b to each variable $v \in \text{Var}(e)$. Thus, under a binding element (t, b) , $G(t)\langle b \rangle$ (or $E(f)\langle b \rangle$) represents the evaluating result of $G(t)$ (or $E(f)$), where f is an arc connected to the transition t . For instance, $[x < 1]\langle \{b(x)=1\} \rangle = \text{false}$ for the guard expression $G(t_{20}) = [x < 1]$ in Fig. 4(a).

Definition 4 (Enabled and Occurrence Rules of PDNet) Let N be a PDNet, (t, b) be a binding element of N , M be a marking of N . A binding element (t, b) is enabled under a marking M , denoted by $M[(t, b)]$, iff

1. $G(t)\langle b \rangle = \text{true}$, and
2. $\forall p \in \bullet t: E(p, t)\langle b \rangle \leq M(p)$.

When (t, b) is enabled under M , it could occur and lead to a new marking M_1 of N , denoted by $M[(t, b)]M_1$, such that

3. $\forall p \in P: M_1(p) = M(p) - E(p, t)\langle b \rangle + E(t, p)\langle b \rangle$.

For ease of expression, if there is a binding b that enables the binding element (t, b) , we call this transition t is enabled and could occur. For instance, under marking m_7 in Fig. 4(b), t_{21} is enabled because $G(t_{21}) = \text{true}$, and $f_{21}, c_{21} \in \bullet t_{21}$ are marked in m_7 meeting $E(f_{21}, t_{21}) \leq M(f_{21}) \wedge E(c_{21}, t_{21}) \leq M(c_{21})$. Suppose $b_{21} \in B[t_{21}]$, $m_7[(t_{21}, b_{21})]m_{12}$, where $c_{2e} \in t_{21} \bullet$ is marked in m_{12} . Then, the occurrence sequence of PDNet is defined based on its enabled and occurrence rules.

Definition 5 (Occurrence Sequence of PDNet) Let N be a PDNet, M_0 be the initial marking of N , (t, b) be a binding element of N . An occurrence sequence ω of N can be defined by the following inductive scheme:

1. $M_0[\varepsilon]M_0$ (ε is an empty sequence),
2. $M_0[\omega]M_1 \wedge M_1[(t, b)]M_2: M_0[\omega(t, b)]M_2$.

An occurrence sequence ω of N is maximal, iff

1. ω is of infinite length (e.g., $(t_1, b_1), (t_2, b_2), \dots, (t_n, b_n), \dots$), or
2. $M_0[\omega]M_1 \wedge \forall t \in T, \nexists (t, b) \in BE(t): M_1[(t, b)]$.

Then, a marking sequence w.r.t. ω , denoted by $M[\omega]$, is generated by occurring all binding elements in turn ω .

Remark 2 The state-space of PDNet consists of the maximal marking sequence, where every marking (state) is reached from the initial marking by an occurrence sequence. All maximal occurrence sequences constitute the language accepted by a PDNet N .

For instance, $t_{1b}, t_{2b}, t_{20}, t_{10}, t_{21}$ is a maximal occurrence sequence in Fig. 4(a). And $m_1, m_2, m_6, m_7, m_8, m_5$ is a marking sequence by occurring $t_{1b}, t_{2b}, t_{20}, t_{10}$ and t_{21} in turn in Fig. 4(b).

3.2 Linear Temporal Logic of PDNet

LTL [26] is an adequate formalism to specify the linear temporal properties for concurrent programs, e.g., the safety properties and the liveness properties. Due to the following slicing purpose, the reduced state-space doesn't include the complete sequence of the original model. Thus, our methods can't preserve operator X , and support LTL- X formulae.

There exist two categories of propositions: LTLFireability and LTLCardinality [18]. In LTLFireability, the propositions are relevant to the fireability of transitions. In LTLCardinality, the propositions are relevant to the number of tokens in places. However, these propositions of LTLCardinality lose the color set information in CPN's places, and can't express the values from the variable place of PDNet. Then, we formalize two propositions of PDNet.

Definition 6 (Proposition and LTL- X Formula of PDNet) Let N be a PDNet, po be a proposition, Po be a set of propositions, and ψ be a LTL- X formula. The syntax of propositions is defined:

$po ::= is - fireable(t) (t \in T) | token - value(p) rop c (p \in P_v, c \in C(p)_{MS} \text{ is a constant, } rop \in \{<, \leq, >, \geq, =\})$.

The proposition semantics is defined w.r.t a marking M :

$$is - fireable(t) = \begin{cases} true & \text{if } \exists b : M[(t, b)] \\ false & \text{otherwise.} \end{cases}$$

$$token - value(p) rop c = \begin{cases} true & \text{if } M(p) rop c \text{ holds} \\ false & \text{otherwise.} \end{cases}$$

The syntax of LTL- X over Po is defined:

$\psi ::= po | \neg\psi | \psi_1 \wedge \psi_2 | \psi_1 \vee \psi_2 | \psi_1 \Rightarrow \psi_2 | \mathcal{F}\psi | \mathcal{G}\psi | \psi_1 \mathcal{U} \psi_2$ (\neg , \wedge , \vee and \Rightarrow are usual propositional connectives, \mathcal{F} , \mathcal{G} and \mathcal{U} are temporal operators, po is a proposition, ψ , ψ_1 and ψ_2 are LTL- X formulae).

The semantics of LTL- X w.r.t. a marking sequence is the same as [18] of Petri nets and abridged due to the limited space. For example, $\mathcal{G} is - fireable(t) \Rightarrow \mathcal{F} token - value(p) = 0$ means that whenever the transition t is enabled, the token of p will be equal to 0 in some subsequent states. The Büchi automaton can encode an LTL- X formula as [26] for the explicit model checking [19], as the example in Fig. 4(c).

Traditionally, the automata-theoretic approach [19] to explicit model checking explores all possible executions of the transition systems (state-space) exhaustively. The model-checking problem for LTL is translated to an emptiness checking problem as the following steps: (1) translate the negation of the verified property into a Büchi automaton [26], (2) compute a product automaton of the concurrent program by intersecting the transition system of each thread, (3) synchronize the product automaton and the Büchi automaton in an adequate way to yield a composed automaton, and (4) check the emptiness of the language of the composed automaton. Among them, (3) and (4)

can be processed with the on-the-fly way, i.e., checking the emptiness while synchronizing.

PDNet could apply the automata-theoretic [19] approach. For the composed automaton of (3), the marking of PDNet N could synchronize with the states of Büchi automaton (i.e., Büchi states) [26] according to Definition 6. That is, the initial composed state is generated by the initial marking of N and the initial Büchi state, and an acceptable path starting from the initial composed state is extended until reaching an acceptable composed state (i.e., a composed state with an acceptable Büchi state) [24]. Thus, $N \models \psi$ holds iff there exists no acceptable sequence reachable from initial composed state. For instance, there exists a counterexample in Fig. 4(d) such that $N \not\models \psi$.

4 Dependencies Modeling Based on PDNet

4.1 PDNet Modeling for Concurrent Program

To model the dependencies based on PDNet, we define the syntax of concurrent programs and model the control-flow structure firstly.

C programs using POSIX threads [25] refers to the concurrent programs in this paper. For simplicity, we consider the assignment statements to be atomic. Take inspiration from the existing researches on the function call [10, 27] and concurrency primitive [12, 28], we describe the complete definitions for the function calls and the concurrency primitives.

Suppose \mathcal{V} is the set of the basic program variables (e.g., the type of *int*, *double*, etc.), val is the set of all values that a variable ν in \mathcal{V} can take. And suppose \mathcal{I} is the set of the thread identifiers (i.e., *pthread_t*), W is the set of program expressions, Q is the set of the operations that characterize the nature of the action performed by the statement.

Definition 7 (Concurrent Programs) $\mathcal{P} ::= \langle K, \mathcal{M}, \mathcal{L}, \mathcal{C}, \mathcal{T}, \mathcal{H}, \mathcal{R}, m_0, h_0 \rangle$ is a concurrent program, where:

1. K is a finite set of all program locations.
2. \mathcal{M} is a set of all memory states.
3. \mathcal{L} is a finite set of POSIX mutex variables (i.e., the type of *pthread_mutex_t*). And $\ell \in \mathcal{L}$ is a mutex.
4. \mathcal{C} is a finite set of condition variables (i.e., the type of *pthread_cond_t*). And $\gamma \in \mathcal{C}$ is a condition variable.
5. $\mathcal{T} \subseteq \mathcal{I} \times Q \times K \times K \times \mathcal{M} \times \mathcal{M}$ is a finite set of statements.
6. $\mathcal{H}: \mathcal{I} \rightarrow K$ is a function that assigns its current location to each thread identifier.
7. $\mathcal{R}: \mathcal{M} \rightarrow val_{MS}$ is a function that assigns the current values of program variables to each memory state.
8. $h_0 \in \mathcal{H}$ is the initial location function, that assigns the initial location to each thread identifier.
9. $m_0 \in \mathcal{M}$ is the initial memory state.

Table 1: Syntax of Concurrent Programs

$\mathcal{P} ::= (\nu^*)fun^+$
$fun ::= entry\ i\ (\nu^*)\ (\tau^*)\ export$
$\tau ::= local calls syncs$
$local ::= \nu := w jump if(w)then(\tau^*)else(\tau^*) while(w)do(\tau^*)$
$jump ::= break continue return$
$w ::= val \nu uop\ w w\ rop\ w$
$calls ::= acall cassign\ acall\ rassign$
$acall ::= call\ cassign\ acall\ rassign\ rets acall\ acall\ \epsilon$
$cassign ::= (\nu := w)^*$
$rassign ::= (\nu := w)^*$
$syncs ::= \langle lock, \ell \rangle \langle unlock, \ell \rangle \langle signal, \gamma \rangle \langle wait, \gamma, \ell \rangle$

Remark 3 A statement $\tau ::= \langle i, q, l, l', m, m' \rangle$ intuitively represents that a thread $i \in \mathcal{I}$ can execute an operation $q \in \mathcal{Q}$, updating the program location from $l \in K$ to $l' \in K$ and the memory state from $m \in \mathcal{M}$ to $m' \in \mathcal{M}$.

The corresponding syntax of the concurrent program \mathcal{P} in this paper is described in Table 1, where ϵ , val , ν , γ , ℓ , uop , rop , $break$, $continue$, $return$, $entry$, $export$, i , if , $then$, $else$, $while$, do , $call$, $rets$, $lock$, $unlock$, $wait$, $signal$ are the terminal symbols of the syntax. Here, ϵ means the default value, uop is the set of unary operators, rop is the set of binary operators. A concurrent program \mathcal{P} contains a series of variable declarations ν^* and function declarations fun^+ . A function fun is uniquely identified by i , and contains an $entry$ and an $export$, and ν^* represents a parameter list that can be default. τ^* is a set of statements within this function.

The behavior of a statement $\tau \in \mathcal{T}$ is represented by its operation q , characterizing the nature of the action performed by this statement. Then, we distinguish the following operation sets $\{local\}$, $\{calls\}$ and $\{syncs\}$ for $\tau ::= local|calls|syncs$ in Table 1. Here, assignment operation, jump operation and branching operation belong to $\{local\}$, call site operation and return site operation belong to $\{calls\}$, and $\langle lock, \ell \rangle$, $\langle unlock, \ell \rangle$, $\langle signal, \gamma \rangle$ and $\langle wait, \gamma, \ell \rangle$ belong to $\{syncs\}$.

(1) The local operations in $local$ could model statements within a local thread. $\nu := w$ represents a simple assignment operation where $\nu \in \mathcal{V}$ is a program variable and $w \in \mathcal{W}$ is an expression over the program variables. $jump$ represents a simple jump operation with a particular symbol (e.g., $break$, $continue$ and $return$). $if(w) then (\tau^*) else (\tau^*)$ (abbreviated as $if(w)$) is a branch conditional structure with a boolean condition denoted by an expression w , and $while(w) do (\tau^*)$ (abbreviated as $while(w)$) is a loop structure with a boolean condition denoted by an expression w . The two structures are the branching operations that produce different possible subsequent executions.

(2) $calls$ could represent possible multiple function calls. As the syntax in Table 1, $call$ represents the function call site operation making the control-flow turn to the called function, and $rets$ represents the return site operation

making the control-flow turn back from the called function. Moreover, *cassign* represents the assignments to all formal input parameters of *call*, and *rassign* represents the assignments to the actual return parameters of *rets*.

(3) The POSIX thread operations in *syncs* could model the synchronization statements in the different threads. $syncs = (\{lock, unlock\} \times \mathcal{L}) \cup (\{signal\} \times \mathcal{C}) \cup (\{wait\} \times \mathcal{C} \times \mathcal{L})$. $\langle lock, \ell \rangle$ represents a request operation to acquire mutex $\ell \in \mathcal{L}$ (i.e., *pthread_mutex_lock*(& ℓ)), while $\langle unlock, \ell \rangle$ represents a request operation to release mutex $\ell \in \mathcal{L}$ (i.e., *pthread_mutex_unlock*(& ℓ)). $\langle signal, \gamma \rangle$ represents a request operation to signal other thread on the condition variable $\gamma \in \mathcal{C}$ (i.e., *pthread_cond_signal*(& γ)). $\langle wait, \gamma, \ell \rangle$ represents a request operation to wait for a notification on condition variable $\gamma \in \mathcal{C}$ with mutex $\ell \in \mathcal{L}$ (i.e., *pthread_cond_wait*(& γ , & ℓ)). Concrete arguments of POSIX thread functions mentioned above can be found from [25].

Then, we describe the semantics of concurrent programs in this paper by labeled transition system in Appendix A. There are 13 actions (i.e., *ass*, *jum*, *ret*, *tcd*, *fcd*, *call*, *rets*, *acq*, *rel*, *sig*, *wa*₁, *wa*₂ and *wa*₃) in Table A1. When modeling the control-flow structure of concurrent programs based on PDNet, specific transitions correspond to the above actions.

For the operations in *local*, *assign* transition is constructed for *ass*, *jump* transition is constructed for *jum*, *exit* transition is constructed for *ret*, and *branch* transitions are constructed for action *tcd* and *fcd*. As the example in Fig. 5(a), *t*₁ (for *a:=1*), *t*₂ (for *b:=2*), *t*₃ (for *c:=3*), *t*₄ (for *d:=c*) are *assign* transitions. *t*_{*i*1} and *t*_{*i*2} are *branch* transitions for *if*(*a* ≠ 0). In this PDNet structure, *f*_{*i*}, *f*₁, *f*₂, *f*₃ and *f*₄ are execution places to describe the execution condition. At the same time, *c*_{*i*}, *c*₁, *c*₂, *c*₃ and *c*₄ are control places to provide interfaces to model control dependencies in the following.

For the operations in *calls*, *call* transition is constructed for *call*, and *return* transition is constructed for *rets*. Particularly, *enter* transition is constructed the *entry* of a called function, *enter* arc and *exit* arc are constructed between functions. As the example in Fig. 5(b), *t*_{*j*} is *call* transition and *t*_{*k*} is *return* transition. And *t*_{*b*} is the *enter* transition of the function *fun*(*s*, *t*). In this PDNet structure, *c*_{*j*}, *c*_{*k*}, *c*_{*b*} and *c*_{*e*} are execution places as well as control places. Thus, (*t*_{*j*}, *c*_{*b*}) is *enter* arc and (*c*_{*e*}, *t*_{*k*}) is *exit* arc, describing the control-flow structure of function call.

For the operations in *syncs*, *lock* transition is constructed for *acq*, *unlock* transition is constructed for *rel*. As the example in Fig. 5(c), *t*_{*l*} is *lock* transition for *pthread_mutex_lock*(& ℓ), and *t*_{*u*} is *unlock* transition for *pthread_mutex_unlock*(& ℓ). And *signal* transition is constructed for *sig*, and *wait* transitions are constructed for *wa*₁, *wa*₂, *wa*₃. As the example in Fig. 5(d), *t*_{*s*} is *signal* transition for *pthread_cond_signal*(& γ), *t*_{*w*1} for action *wa*₁, *t*_{*w*2} for action *wa*₂ and *t*_{*w*3} for action are *wait* transitions from *pthread_cond_wait*(& γ , & ℓ). In the two PDNet structures, *c*_{*l*}, *c*_{*u*}, *c*_{*w*1}, *c*_{*w*2} and *c*_{*w*3} are execution places as well as control places. Also, *v*_{*m*} for ℓ and *v*_{*c*} for γ are execution places as well as control places. Similarly, the corresponding arcs could describe the control-flow structure of the synchronization statements with the POSIX functions.

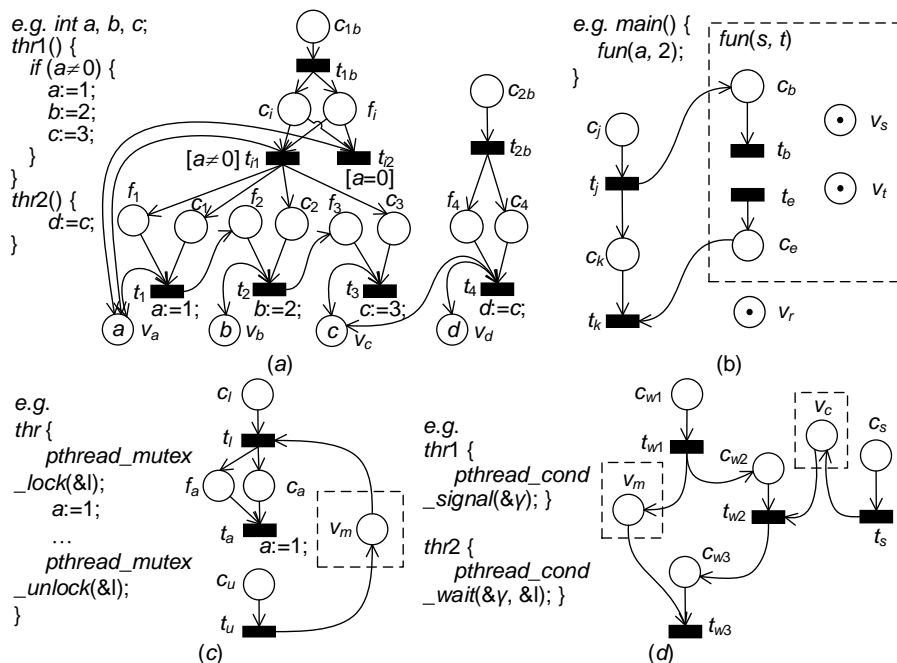

Fig. 5: Example for Control-flow Structure and Dependencies (a) Structure for local operations (b) Structure for calls operations (c) Structure for $\langle lock, \ell \rangle, \langle unlock, \ell \rangle$ (d) Structure for $\langle signal, \gamma \rangle, \langle wait, \gamma, \ell \rangle$

4.2 Control-flow Dependencies Based on PDNet

We describe the complete dependencies for the function calls [27] and the concurrency primitives [25] of the concurrent programs based on our unified model PDNet in this paper.

Traditionally, the control-flow dependencies describe the domination relation between statements [27, 29, 30]. However, different dependencies are defined in different dependence graphs [9–11, 31]. We classify the control-flow dependencies into control dependence, call dependence, lock dependence and happen-before dependence, and propose a unified characterization based on PDNet for these dependencies. Firstly, we define the execution path, control scope and critical region of PDNet.

Definition 8 (Execution Path of PDNet) Let N be a PDNet, t_m and t_n are the two different transitions of N . A sequence π along the transitions and arcs of N is denoted by $(t_1, f_1, t_2, f_2, \dots, t_{k-1}, f_{k-1}, t_k)$, where (t_i, f_i) and (f_i, t_{i+1}) ($1 \leq i < k$) are the execution arcs of N . The sequence π is an execution path from t_m to t_n iff t_1 is t_m , t_k is t_n , and $k \geq 1$.

All execution paths from t_m to t_n constitute the execution path set, denoted by $Path(t_m, t_n)$. The transition t_n is reachable from t_m , denoted by $Reach(t_m, t_n)$,

iff $Path(t_m, t_n) \neq \emptyset$. Particularly, t_n is reachable from t_m irrelevant to arc (t_i, f_i) , denoted by $Reach(t_m, t_n)_{-(t_i, f_i)}$, iff $\forall \pi \in Path(t_m, t_n), (t_i, f_i) \notin \pi$.

Definition 9 (Control Scope of PDNet) Let N be a PDNet, t_m be a *branch* transition or *enter* transition of N , and t_n be a transition of N . Thus, t_n is in the control scope of t_m , denoted by $Cons(t_m, t_n)$, iff

1. $Reach(t_m, t_n)$, and
2. there exists an execution path starting in t_m that does not contain t_n .

Definition 10 (Critical Region of PDNet) Let N be a PDNet, t_m be a *lock* transition of N , and t_n be a transition of N . t_m could acquire a mutex ℓ . Thus, t_n is in the critical region of t_m , denoted by $CriR(t_m, t_n)$, iff

1. $Reach(t_m, t_n)$, and
2. there exists no *unlock* transition that releases the same mutex ℓ in any execution paths from $Path(t_m, t_n)$.

As the example in Fig. 5(a), $(t_{1b}, t_{i1}, f_1, t_1, f_2, t_2, f_3, t_3)$ is an execution path. t_3 is reachable from t_{i1} , i.e., $Reach(t_{i1}, t_3)$. And t_1, t_2, t_3 is in the control scope of t_{i1} , i.e., $Cons(t_{i1}, t_1)$, $Cons(t_{i1}, t_2)$ and $Cons(t_{i1}, t_3)$. As the example in Fig. 5(c), t_a is in the critical region of t_l , i.e., $CriR(t_l, t_a)$. Then, we define the four kinds of control-flow dependencies based on the above definitions.

Definition 11 (Control-flow Dependencies of PDNet) For a concurrent program \mathcal{P} , N is the PDNet of \mathcal{P} , t_m and t_n are two transitions of N :

1. t_m is control dependent on t_n , denoted by $t_n \xrightarrow{cd} t_m$, iff t_n is a *branch* transition or *enter* transition, $Cons(t_n, t_m)$, and there exists no other *branch* transition t_o in the control scope of t_n that $Cons(t_o, t_m)$.
2. t_m dependent call dependent on t_n , denoted by $t_n \xrightarrow{ad} t_m$, iff
 - i. t_m is an *enter* transition of the called function, and t_n is the *call* transition of the calling function, making the execution flow turn to t_m , or
 - ii. t_n is an *exit* transition of the called function, and t_m is the *return* transition of the calling function, making the execution flow turn back to t_m .
3. t_m is lock dependent on t_n , denoted by $t_n \xrightarrow{ld} t_m$, iff
 - i. t_n is a *lock* transition acquiring ℓ , and $CriR(t_n, t_m)$, or
 - ii. t_m and t_n are all *lock* transitions that acquire ℓ .
4. t_m is happen-before dependent on t_n , denoted by $t_n \xrightarrow{hd} t_m$, iff t_m is a *wait* transition waiting for a condition variable γ , and t_n is a *signal* transition notifying on the same condition variable γ .

Intuitively, we define the control dependence for the nearest *branch* or *enter* transition of PDNet. That is, a *branch* or *enter* transition could dominate the execution of the following transitions that are not in other transition's control scope. Because the PDNet control-flow structure provides the control place interfaces (e.g., c_1, c_2 and c_3 in Fig. 5(a)) to describe the control dependencies.

The control arcs between a *branch* or *enter* transition and the control places are constructed for the control dependencies.

As the example in Fig. 5(a), a , b and c are global variables initialized to 1 in this program. The PDNet structures of the branching operation $if(a \neq 0)$ and assignment operations $a:=1$, $b:=2$ and $c:=3$ are constructed by modeling these operations. Thus, the control arcs (t_{i1}, c_1) , (t_{i1}, c_2) and (t_{i1}, c_3) are constructed to describe the control dependencies based on the Definition 11. That is, the control dependencies $t_{i1} \xrightarrow{cd} t_1$, $t_{i1} \xrightarrow{cd} t_2$ and $t_{i1} \xrightarrow{cd} t_3$ are represented explicitly.

Differently, other control-flow dependencies have described by modeling function call operations and POSIX thread operations. For example, the call dependencies $t_j \xrightarrow{ad} t_b$ and $t_e \xrightarrow{ad} t_k$ are represented in Fig. 5(b), the lock dependence $t_l \xrightarrow{ld} t_a$ is represented in Fig. 5(c), and the happen-before dependence $t_{w2} \xrightarrow{hd} t_s$ is represented in Fig. 5(d).

4.3 Data-flow Dependencies Based on PDNet

Traditionally, the data-flow dependencies describe the reachable definition-use relation of the variables. We classify the data-flow dependencies into data dependence [9] and interference dependence [11]. Firstly, we define the reference set and definition set of PDNet.

Definition 12 (Reference Set and Definition Set of PDNet) Let N be a PDNet, t be a transition of N .

The reference set of transition t , denoted by $Ref(t)$, is defined by $Ref(t) ::= \{p \in P_v \mid \forall p \in \bullet t : E(p, t) = E(t, p)\}$.

The definition set of transition t , denoted by $Def(t)$ is defined by $Def(t) ::= \{p \in P_v \mid \forall p \in \bullet t : E(p, t) \neq E(t, p)\}$.

Definition 13 (Data-flow Dependencies of PDNet) For a concurrent program \mathcal{P} , N is the PDNet of \mathcal{P} , t_m and t_n are two transitions of N , if there is a variable place v , such that

1. t_m data depends on t_n , denoted by $t_n \xrightarrow{dd} t_m$, iff
 - i. $Reach(t_n, t_m)$, and
 - ii. $v \in Ref(t_m) \wedge v \in Def(t_n)$, and
 - iii. $\exists \pi \in Path(t_n, t_m)$, there exists no other transition $t_a \in \pi$ such that $v \in Def(t_a)$.
2. t_m interference depends on t_n , denoted by $t_n \xrightarrow{id} t_m$, iff
 - i. there exist execution places $f_m \in (\bullet t_m \cap P_f)$ and $f_n \in (\bullet t_n \cap P_f)$ such that $M(f_m) \neq M(f_n)$, and
 - ii. $v \in Ref(t_m) \wedge v \in Def(t_n)$.

In the above definition 2.i, $M(f_m) \neq M(f_n)$ means that the operations corresponding to t_m and t_n belong to different concurrently executing threads. For instance, the data dependence $t_{11} \xrightarrow{dd} t_{12}$ is represented in Fig. 2(e). The

interference dependencies $t_{10} \xrightarrow{id} t_{20}$ and $t_3 \xrightarrow{id} t_4$ are represented in Fig. 2(e) and in Fig. 5(a), respectively.

Since we define the data-flow dependencies based on the read-write arcs and the control-flow structure of PDNet, the data-flow dependencies could be captured on demand. Hence, no additional arcs are added to represent the data-flow dependencies, but the data-flow dependencies could be calculated by the read-write arcs during slicing based on PDNet. Furthermore, there exist only data dependencies between t_m and t_n if the variable place v corresponds to a local variable. And if v corresponds to a global variable, t_m may be data or interference dependent on t_n . It can help to reduce some calculating costs.

Above all, a concurrent program with POSIX threads could be translated to a PDNet and be verified by the PDNet.

5 On-demand PDNet Slicing for Reduction

5.1 Slicing Criterion of PDNet

The main idea of PDNet slicing is that it can remove the portions irrelevant to the verified property to reduce the model size and the reachable state space. The program features mentioned in the verified LTL- X property form the slicing criterion. Thus, we extract the slicing criterion relevant to an LTL- X property firstly.

Definition 14 (Slicing Criterion of PDNet) Let N be a PDNet, ψ be a LTL- X formula with propositions in Definition 6, Po be the proposition set from ψ , $Crit$ be the slicing criterion w.r.t. ψ .

If a proposition po is in the form of *is-fireable*(t), $Crit(po) ::= \{p \in P \mid p \in \bullet t \setminus P_f\}$.

And if a proposition po is in the form of *token-value*(p_t) *rop* c , $Crit(po) ::= \{p \in P \mid \forall t \in \bullet p_t: E(t, p_t) \neq E(p_t, t) \wedge p \in \bullet t \setminus P_f\}$.

Thus, the slicing criterion of N is defined by $Crit ::= \{p \in P \mid \forall po \in Po: p \in Crit(po)\}$.

Hence, each proposition in the LTL- X formula ψ shall extract the places from a PDNet N as the slicing criterion $Crit$. The slicing criterion extracting algorithm based on Definition 14 is shown as follows.

Algorithm 1 Slicing Criterion Extracting Algorithm

Input: A PDNet N and its LTL- X formula ψ ;

Output: The slicing criterion $Crit$ w.r.t. ψ ;

```

1:  $Crit := \emptyset$ ; /*Initialize  $Crit$  by  $\emptyset$ */
2:  $Po := FPO(\psi)$ ; /*FPO gets all propositions in  $\psi$ */
3: for all  $po \in Po$  do /* $Po$  is the proposition set of  $\psi$ */
4:   if  $po$  is the form of is-fireable( $t$ ) then /* $t$  is a transition of  $N$ */
5:      $Crit := Crit \cup \{\bullet t \setminus P_f\}$ ; /* $P_f$  is the execution place set of  $N$ */
6:   else /* $po$  is the form of token-value( $p$ ) rop  $c$ ,  $p$  is a variable place*/
7:     for all  $t \in \bullet p \wedge E(t, p) \neq E(p, t)$  do /*( $t, p$ ) and ( $p, t$ ) belong to  $F_{rw}$ */
8:        $Crit := Crit \cup \{\bullet t \setminus P_f\}$ ; /* $P_f$  is the execution place set of  $N$ */
9:     end for

```

```

10: | end if
11: end for

```

Function FPO can find all propositions in the form defined by Definition 6 in ψ (Line 2). For every proposition po in Po , the corresponding places for po are extracted based on Definition 14 (Line 4-10). If po is in the form of $is - fireable(t)$ (Line 4), the places expect execution places in $\bullet t$ are added to $Crit$ (Line 5). If po is in the form of $token - value(p) rop c$ where p is a variable place (Line 6), the transitions in $\bullet p$ that could update the token of p are found by $E(t, p) \neq E(p, t)$ (Line 7). Then, the places except the execution places in $\bullet(\bullet p)$ are added to $Crit$ (Line 8). Finally, the slicing criterion $Crit$ w.r.t. ψ forms a subset of P when all iterations end.

For example, there is a proposition $is - fireable(t_{21})$ in $\mathcal{F} is - fireable(t_{21})$ of the PDNet in Fig. 2(e). Due to $\bullet t_{21} = \{f_{21}, c_{21}\}$, c_{21} is added to $Crit$ by Line 5 in Algorithm 1.

5.2 On-demand PDNet Slicing Algorithm

As mentioned above, differently from the traditional program slicing method, we propose an on-demand slicing method based on PDNet that the data-flow dependencies of Definition 13 won't be captured completely in the following.

Let N be the PDNet of \mathcal{P} , and $Crit$ be a slicing criterion of N . And \xrightarrow{d} represents the union of all dependencies of PDNet.

Definition 15 (PDNet Slice) Let N be a PDNet, ψ be a LTL- X formula, $Crit$ be the slicing criterion w.r.t. ψ , N' be the PDNet slice of N w.r.t. $Crit$. Then, $N' ::= \{x \in P \cup T \mid \forall p \in Crit : x \xrightarrow{d} * p\}$.

Here, $*$ represents the possible transitive relations of \xrightarrow{d} , and \xrightarrow{d}^* represents the transitive closure of the dependencies of PDNet. That is, no matter a place is added according to which dependencies, the dependencies of \xrightarrow{d} are used to calculate the transitive closure. For a control place p in $Crit$, the transitions which directly or indirectly affect p in a marking through the constructed arcs that characterize the control-flow dependencies are captured, and their control places should be added to N' . As the example in Fig. 2(e), $\{c_{21}\}$ is the criterion for $\mathcal{F} is - fireable(t_{21})$. Due to $t_{2b} \xrightarrow{cd} t_{20}$ and $t_{20} \xrightarrow{cd} t_{21}$ according to Definition 11, $t_{2b} \xrightarrow{cd}^* t_{21}$ (i.e., t_{2b} affects t_{21} indirectly), and the control place c_{2b} of t_{2b} could be added to P' of N' .

Differently, when a variable place is added to P' of N' , its data-flow dependencies could be calculated through the control-flow structure and the read-write arcs according to Definition 13. As the example in Fig. 2(e), when t_{20} is added to P' , v_0 could be added to P' . Then, $t_{10} \xrightarrow{id} t_{20}$ concerning the variable place v_0 could be captured, and the control place c_{10} of t_{10} is added to P' of N' .

Based on the above definition and idea, our on-demand PDNet slicing algorithm is proposed as follows.

Algorithm 2 On-demand PDNet Slicing Algorithm

Input: A PDNet N and the slicing criterion $Crit$ w.r.t. ψ ;

Output: The PDNet Slice N' with P' and T' ;

```

1:  $P' := Crit$ ; /* $P'$  is the place set of  $N'$ */
2:  $T' := \emptyset$ ; /* $T'$  is the transition set of  $N'$ */
3:  $P_d := \emptyset$ ; /* $P_d$  is a processed place set*/
4: PROPA(enter); PROPA(exit);
5: function PROPA(Dir)
6:   for all  $p \in (P' \cap P_c \setminus P_d)$  do
7:     for all  $t \in (\bullet p \setminus T') \wedge (t, p) \in F_c$  do
8:       for all  $p' \in (\bullet t \setminus P') \wedge (p', t) \in F_c$  do
9:          $P' := P' \cup \{p'\}$ ;
10:      end for
11:    end for /*Propagate by the control-flow dependencies*/
12:    for all  $t \in p \bullet \wedge (p, t) \in F_c$  do
13:       $T' := T' \cup \{t\}$ ;
14:       $P' := P' \cup (\bullet t \cap P_f)$ ;
15:      for  $p' \in (\bullet t \setminus P' \cap P_v) \wedge E(t, p') = E(p', t)$  do
16:        if ISGLOBAL( $p'$ ) then
17:           $P' := P' \cup \{p'\}$ ;
18:          for  $t' \in \bullet p' \wedge E(t', p') \neq E(p', t')$  do /* $p' \in Def(t')$ */
19:            if INPA( $t', t, p'$ )  $\vee$  INCON( $t', t, p'$ ) then /* $t' \xrightarrow{id} t$  or
 $t' \xrightarrow{dd} t$ */
20:              for  $p'' \in (\bullet t' \setminus P') \wedge (p'', t') \in F_c$  do
21:                 $P' := P' \cup \{p''\}$ ;
22:              end for
23:            end if
24:          end for
25:        end if /* $p'$  corresponds to a global variable*/
26:        if ISLOCAL( $p'$ ) then
27:           $T_d := \text{FINDPRE}(t, p', Dir)$ ;
28:          if  $T_d \neq \emptyset$  then  $P' := P' \cup \{p'\}$ ;
29:          end if
30:        for  $t' \in T_d$  do /* $t' \xrightarrow{dd} t$ */
31:          for  $p'' \in (\bullet t' \setminus P') \wedge (p'', t') \in F_c$  do
32:             $P' := P' \cup \{p''\}$ ;
33:          end for
34:        end for
35:        end if /* $p'$  corresponds to a local variable*/
36:      end for
37:    end for /*Propagate by the data-flow dependencies*/
38:     $P_d := P_d \cup \{p\}$ ;
39:  end for /*Until  $P' \cap P_c \setminus P_d = \emptyset$ */
40: end function /*Function PROPA(Dir)*/

```

Firstly, P' , T' and P_d are initialized (Line 1-3). There are two calls of $\text{PROPA}(Dir)$ (Line 4) avoiding redundancy caused by multiple calls [10]. The difference between these two calls is the propagation direction from the call dependence in Definition 11 2.i and 2.ii. In function $\text{PROPA}(Dir)$, if there is an unprocessed control place p (Line 6), the control-flow dependencies is propagated from p (Line 7-11) and the data-flow dependencies is propagated from p (Line 12-37). The key slicing steps are as follows.

(1) A transition $t \in \bullet p$ is propagated by the control arc (t, p) (Line 7). Here, the control arcs describe which statements dominate the current statement corresponding to p . According to the control-flow dependencies in Definition 11, $t \xrightarrow{cd} t'$ or $t \xrightarrow{ad} t'$ or $t \xrightarrow{ld} t'$ or $t \xrightarrow{hd} t'$ where t' is the transition of the PDNet structure for the operation where p locates. Thus, the control place p' of t is added to P' (Line 8-9).

(2) To complete the PDNet structure of the operation where p locates, the corresponding transition $t \in p \bullet$ is added to T' (Line 13) and the corresponding execution place in $\bullet t$ is added to P' (Line 14).

(3) It's the core of our on-demand calculation of the data-flow dependencies. If there is a variable place $p' \in \text{Ref}(t)$ (Line 15), the data-flow dependencies relevant to p' could be captured based on Definition 13. As the analysis mentioned above, the interference dependencies are captured only for a global variable to reduce the calculating costs. Thus, if p' corresponds to a global variable (Line 16-25), p' is added to P' (Line 17). If there exists a transition t' such that $p' \in \text{Def}(t')$ (Line 18), function $\text{INPA}(t', t, p')$ judges whether $t' \xrightarrow{dd} t$ according to Definition 13 1.i and 1.iii, function $\text{INCON}(t', t, p')$ judges whether $t' \xrightarrow{id} t$ according to Definition 13 2.i (Line 19), and the control places of t' are added to P' (Line 20-21). If p' corresponds to a local variable (Line 26-37), function $\text{FINDPRE}(t, p', Dir)$ finds the transition set $T_d := \{\forall t' \in T \mid p' \in \text{Def}(t') \wedge \text{Reach}(t', t)_{-Dir} \wedge (\forall t'' \in \text{Path}(t', t) : p' \notin \text{Def}(t''))\}$ according to Definition 13 1.i and 1.iii (Line 27). Here, Dir is *enter* arc or *exit* arc. The control places of t' are added to P' (Line 31-32).

(4) The control place p is added to P_d as a processed place (Line 38).

The complexity of Algorithm 2 is, in the best case, $O(n)$, where n is the statement number. The worst-case complexity is $O(n^2)$ when the algorithm cannot slice any statement.

However, N' could be non-executable due to the incomplete execution orders concerning control-flow structure. Hence, the slicing post-process algorithm is proposed to complete the control-flow structure for model checking.

Algorithm 3 Slicing Post-process Algorithm

Input: A PDNet N and its slice N' w.r.t. $Crit$;

Output: The final PDNet slice N'' ;

- 1: **for all** $p \in (P' \cap P_f) \wedge (\forall t \in \bullet p : (t, p) \notin F_f')$ **do** $/*F_f'$ is the execution arc set*/
- 2: $T_f := \text{FINDEXE}(t, T)$; $/*T$ is the transition set of $N*$ /
- 3: **for all** $t' \in T_f$ **do**
- 4: $\text{ADDARC}(t', p)$; $/*(t', p)$ is a new execution arc*/

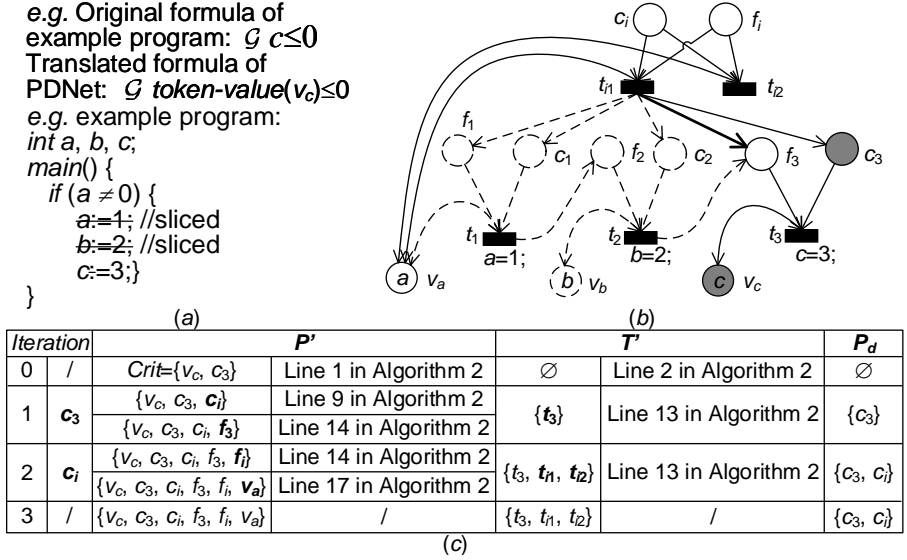

Fig. 6: Example for slicing process (a) The property and the example program (b) The marked PDNet slice (c) The slicing process by Algorithm 2

```

5: | end for
6: end for

```

If there exists an execution place p of N' that lacks execution arcs connected to any transition in $\bullet p$, the execution order of p isn't complete (Line 1). Function $FINDEXE(t, T)$ could find the transitions performed before the transition in $\bullet p$ based on T (Line 2). For each transition t' in T_f , a new execution arc (t', p) is constructed by $ADDARC(t', p)$ (Line 4) to complete the control-flow structure. Finally, the final PDNet slice N'' is tractable for the following model checking.

As the example in Fig. 6, we set $\mathcal{G} token\text{-}value(v_c) \leq 0$ as the example property, and $a:=1$ and $b:=2$ could be sliced for this property in Fig. 6(a). And the original PDNet of the example program is in Fig. 6(b).

Firstly, we extract $Crit$ through Algorithm 1. There is only a proposition $token\text{-}value(v_c) \leq 0$, where v_c is the variable place corresponding to the variable c . Due to $E(t_3, v_c) \neq E(v_c, t_3)$, $\bullet t_3 \setminus P_f$ is extracted according to Definition 14, and $Crit = \{v_3, c_3\}$ is filled with dark gray.

Then, we calculate P' and T' through Algorithm 2. In the table of Fig. 6(c), P' and T' is updated in each iteration. Initially, $P' = \{v_c, c_3\}$ by Line 1, $T' = \emptyset$ by Line 2, and $P_d = \emptyset$ by Line 3 of Algorithm 2. In the first iteration, c_3 is selected as the control place in Line 6 of Algorithm 2. Control place c_i is added to P' by Line 9 according to control dependence in Definition 11. Transition t_3 is added to T' by Line 13 and execution place f_3 is added to P' by Line 14 of Algorithm 2. And c_3 is marked in P_d as a processed place by Line 38 of Algorithm 2. In the second iteration, c_i is selected in $P' \cap P_c \setminus P_d$ in Line 6. Transition t_{i1} (t_{i2} with the same process) is added to T' by Line 13

and execution place f_i is added to P' by Line 14 of Algorithm 2. For data-flow dependencies in Definition 13, variable place v_a is selected in Line 15 due to $E(t_{i1}, v_a) = E(v_a, t_{i1})$. a corresponding to v_a is a global variable, and v_a is added to P' by Line 17. Then, a transition t_a is selected due to $E(t_a, v_a) \neq E(v_a, t_a)$. But there exists no execution path by function INPA by Line 19 of Algorithm 2 and no control place is added to P' . And c_i is marked in P_d as a processed place by Line 38 of Algorithm 2.

Finally, no control place is selected according to P' and P_d in Line 6. The dotted places and dotted arcs as well as the transitions t_1, t_2 are sliced away in Fig. 6(b). However, there is no transition t in $\bullet f_3$ such that $(t, f_3) \in F'_f$ (Line 1 in Algorithm 3). Thus, a new execution arc (t_{i1}, f_3) expressed as a bolded arrow is constructed by Line 4 in Algorithm 3.

5.3 Correctness Proof

We prove the correctness of the PDNet slice N' expressed by $N \models \psi \Leftrightarrow N' \models \psi$. Firstly, we give some definitions for the correctness proof. Note that an occurrence sequence is defined in Definition 5, and an LTL- X formula is defined in Definition 6.

Definition 16 (Marking Projection) Let N be a PDNet and M be a marking of N . Let ψ be an LTL- X formula of N , and $Crit$ be a place subset extracted from ψ . A projection function $\downarrow [\psi]M : Crit \rightarrow EXPR_\emptyset$ is a local marking function w.r.t. $Crit$, that assigns an expression $M(p)$ to each place p . $\forall p \in Crit: Type[M(p)] = C(p)_{MS} \wedge (Var(M(p)) = \emptyset)$.

Definition 17 (ψ -equivalent Marking) Let N be a PDNet and ψ be an LTL- X formula of N . Let M and M' be two markings of N . Then M and M' are ψ -equivalent, denoted by $M \overset{\psi}{\rightsquigarrow} M'$, if $\downarrow [\psi]M = \downarrow [\psi]M'$.

Definition 18 (ψ -stuttering Equivalent Transition) Let N be a PDNet and ψ be an LTL- X formula of N . Let ω be the occurrence sequence $(t_1, b_1), (t_2, b_2), \dots, (t_{i-1}, b_{i-1}), (t_i, b_i), (t_{i+1}, b_{i+1}), \dots, (t_n, b_n)$ of N defined in Definition 5, and $M(\omega)$ be the marking sequence $M_0, M_1, \dots, M_{i-1}, M_i, M_{i+1}, \dots, M_n$ generated by occurring every binding element of ω in turn. Then, t_i ($1 \leq i \leq n$) is a ψ -stuttering equivalent transition if M_{i-1} and M_i are ψ -equivalent, i.e., $M_{i-1} \overset{\psi}{\rightsquigarrow} M_i$.

Definition 19 (ψ -stuttering Equivalent Marking Sequences) Let N be a PDNet, ψ be an LTL- X formula of N , ω be an occurrence sequence of N , and $M(\omega)$ be the marking sequence of ω starting from M_0 . ω' is generated by eliminating some binding elements from ω , and $M(\omega')$ be marking sequence of ω' starting from M'_0 . $M(\omega)$ and $M(\omega')$ are ψ -stuttering equivalent marking sequences, denoted by $M(\omega) \overset{st\psi}{\rightsquigarrow} M(\omega')$, if $\downarrow [\psi]M_0 = \downarrow [\psi]M'_0$, and the eliminated transitions from ω are ψ -stuttering equivalent transitions. That is, the ψ -non-stuttering equivalent transitions of ω are all preserved in ω' .

Definition 20 (ψ -stuttering Equivalent PDNets) Let N be a PDNet and ψ be an LTL- X formula of N . Let N' be a PDNet with the same LTL- X formula ψ . Let M_0 be the initial marking of N , and M'_0 be the initial marking of N' . Then, N and N' are ψ -stuttering equivalent PDNets, denoted by $N \overset{st_\psi}{\rightsquigarrow} N'$, if

- i. $\downarrow [\psi]M_0 = \downarrow [\psi]M'_0$, and
- ii. for each marking sequence $M(\omega)$ of N starting from M_0 , there exists a marking sequence $M(\omega')$ of N' starting from M'_0 such that $M(\omega) \overset{st_\psi}{\rightsquigarrow} M(\omega')$, and
- iii. for each marking sequence $M(\omega')$ of N' starting from M'_0 , there exists a marking sequence $M(\omega)$ of N starting from M_0 such that $M(\omega') \overset{st_\psi}{\rightsquigarrow} M(\omega)$.

Theorem 1 Let N be a PDNet and ψ be an LTL- X formula of N . Let N' be a PDNet with the same LTL- X formula ψ . Any LTL- X formula is invariant under stuttering, denoted by $N \overset{st_\psi}{\rightsquigarrow} N'$, iff

$$N \models \psi \Leftrightarrow N' \models \psi.$$

The above theorem shows that an LTL- X formula ψ is invariant under stuttering [32].

Theorem 2 Let N be a PDNet, M_0 be the initial marking of N , and ψ be an LTL- X formula of N . Let $Crit$ be extracted from ψ by Algorithm 1, and N' w.r.t. $Crit$ be the final PDNet slice from N by Algorithm 2 and 3. Let M'_0 be the initial marking of N' . Then, $N \overset{st_\psi}{\rightsquigarrow} N'$.

Proof According to Definition 20 i, $\downarrow [\psi]M_0 = \downarrow [\psi]M'_0$ obviously holds, because we keep all places in $Crit$, and Algorithm 2 doesn't change the initial marking of N .

Then, we shall prove Definition 20 ii. Let ω be an occurrence sequence of N arbitrarily. There exists an occurrence sequence ω' is generated by eliminating some binding elements from ω by Algorithm 2. And $M(\omega)$ is the marking sequence corresponding to ω , and $M(\omega')$ is the marking sequence corresponding to ω' . We prove $M(\omega) \overset{st_\psi}{\rightsquigarrow} M(\omega')$ using structural induction on the length of occurrence sequence of ω , denoted by $|\omega|$.

Base case: Let $|\omega|=1$, it obviously holds by $\downarrow [\psi]M_0 = \downarrow [\psi]M'_0$.

Induction: Assume that it holds when $|\omega|=k$. That is, $\omega=(t_{i1}, b_{i1}), (t_{i2}, b_{i2}), \dots, (t_{ik}, b_{ik})$ of N , $\omega'=(t_{j1}, b_{j1}), (t_{j2}, b_{j2}), \dots, (t_{jm}, b_{jm})$ ($m \leq k$), and $M(\omega) \overset{st_\psi}{\rightsquigarrow} M(\omega')$. Then we consider whether it holds when $|\omega|=k+1$. Suppose the last transition is t_{k+1} , and $\omega(t_{k+1}, b_{k+1})$ is the extended occurrence sequence. There are two cases for ω' : t_{k+1} is sliced and t_{k+1} is remained.

Case 1: t_{k+1} is sliced by Algorithm 2. That is, $\nexists p \in Crit: t_{k+1} \xrightarrow{d}^* p$. Consider the two proposition forms. Let po be a proposition from ψ arbitrarily. If po is in the form of $token - value(p_t) \text{ rop } c$, $t_{k+1} \notin \bullet p_t$ or $E(t_{k+1}, p_t) = E(p_t, t_{k+1})$, and the evaluation of this proposition under each marking isn't change. If po is in the form of $is - fireable(t)$, t_{k+1} doesn't affect the enabling condition of t according to Definition 14 and Algorithm 2, and the evaluation of this proposition under each

marking isn't change. Thus, t_{k+1} is a ψ -stuttering equivalent transition. As a result, $M(\omega(t_{k+1}, b_{k+1})) \overset{st_\psi}{\rightsquigarrow} M(\omega')$.

Case 2: t_{k+1} is remained, and $\omega'(t_{k+1}, b_{k+1})$ is the extended occurrence sequence. According to $M(\omega) \overset{st_\psi}{\rightsquigarrow} M(\omega')$, t_{k+1} produces the same effect for ω and ω' . As a result, $M(\omega(t_{k+1}, b_{k+1})) \overset{st_\psi}{\rightsquigarrow} M(\omega'(t_{k+1}, b_{k+1}))$.

Finally, we shall prove Definition 20 iii. Let ω' be an occurrence sequence of N' arbitrarily. There exists an occurrence sequence ω is generated by adding some binding elements to ω' that are identified by Algorithm 2. And $M(\omega')$ is the marking sequence corresponding to ω' , and $M(\omega)$ is the marking sequence corresponding to ω . Then, we prove $M(\omega') \overset{st_\psi}{\rightsquigarrow} M(\omega)$ using structural induction on the length of occurrence sequence ω' , denoted by $|\omega'|$.

Base case: Let $|\omega'|=1$, it obviously holds by $\downarrow [\psi]M'_0 = \downarrow [\psi]M_0$.

Induction: Assume that it holds when $|\omega'|=k'$. That is, $\omega'=(t_{i_1}, b_{i_1}), (t_{i_2}, b_{i_2}), \dots, (t_{i_{k'}}, b_{i_{k'}})$ of N , $\omega=(t_{j_1}, b_{j_1}), (t_{j_2}, b_{j_2}), \dots, (t_{j_{m'}}, b_{j_{m'}})$ ($m' \geq k'$), and $M(\omega') \overset{st_\psi}{\rightsquigarrow} M(\omega)$. Then we consider whether it holds when $|\omega'|=k'+1$. Suppose the last transition is $t_{k'+1}$, and $\omega'(t_{k'+1}, b_{k'+1})$ is the extended occurrence sequence. Obviously, $t_{k'+1}$ belongs to ω , and $\omega(t_{k'+1}, b_{k'+1})$ is the extended occurrence sequence. $t_{k'+1}$ produces the same effect for ω and ω' . As a result, $M(\omega'(t_{k'+1}, b_{k'+1})) \overset{st_\psi}{\rightsquigarrow} M(\omega(t_{k'+1}, b_{k'+1}))$.

Thus, $N \overset{st_\psi}{\rightsquigarrow} N'$ holds based on Definition 20. \square

Theorem 3 *Let N be a PDNet and ψ be an LTL- X formula. Let $Crit$ be extracted from ψ by Algorithm 1. Let N' w.r.t. $Crit$ be a reduced PDNet by Algorithm 2 and 3. For the LTL- X formula ψ , $N \models \psi \Leftrightarrow N' \models \psi$.*

Proof It's obvious that $N \overset{st_\psi}{\rightsquigarrow} N'$ proved by Theorem 2. Thus, $N \models \psi \Leftrightarrow N' \models \psi$ iff $N \overset{st_\psi}{\rightsquigarrow} N'$ according to Theorem 1. Therefore, this corollary obviously holds. \square

Hence, it can be concluded that the PDNet slice obtained by our methods is correct based on Theorem 3.

6 Experimental Evaluation

6.1 Implementation

We implemented a concurrent program model checking tool *DAMER* (Dependence Analyser and Multi-threaded programs checkER) based on PDNet. It translates the input programs to a PDNet automatically without any manual intervention. In turn, our on-demand PDNet slicing method is implemented to reduce the PDNet. Then, PDNet slice could be checked by *EnPAC* [33]. *DAMER* supports the features of C programs with POSIX threads [25] represented in Table 1. And *DAMER* supports multiple forms of linear temporal properties, e.g., assertion violation, error location reachability and LTL- X formulae (defined in Definition 6). Here, assertion violation or error location

reachability can be expressed as an LTL- X formula. The verified properties with propositions relevant to program variables or program locations could be translated into the formula corresponding to PDNet automatically in *DAMER*. As the example in Fig. 2(a), *error()* is translated to *is - fireable(t₂₁)* when modeling the PDNet of Fig. 2(e).

To demonstrate the practical effectiveness of our methods by *DAMER* on the linear temporal property verification, we use the following benchmarks. There are five concurrent programs without POSIX thread functions. *Fib* is a mathematical algorithm that divides a task into multiple threads and then merges the constraints of each computation. *Lamport*, *Dekker*, *Szymanski*, *Peterson* are four classic algorithms for solving the mutual exclusion problem in concurrent systems. And there are five concurrent programs with POSIX thread functions. *Sync* is an example program that implements the thread synchronization by a condition variable. *Datarace*, *Varmutex*, *Rwlock* and *Lazy* all access to shared memory protected by a single lock on mutex. For each concurrent program, we set two formulae to specify their safety properties expressed by a specific *error* location and constraint properties expressed by the constraints relevant to the key variables. The benchmarks and released version of tool used in the evaluation are the first and second supplementary file for reproducing our results. Our source code could be public¹.

The experiments are conducted under 16GB memory and a 3.0GHz Inter processor. For the used benchmarks, the variation in the time between different runs of the methods is relatively small. Therefore, it's sufficient to run them 10 times, and we report the average results in the following. And the original complete result is the third supplementary file. The concrete verified formulae (ψ_1 and ψ_2) in the following tables for each benchmark are also shown in this supplementary file. Here, all reported time are in milliseconds. The whole process of each verified property for each benchmark is called an execution in the following.

We compare the performance of our method (called *PDNet* method) with slicing concurrent programs for model checking (called *PS* method). *PS* method firstly builds the PDG based on traditional control-flow dependencies and data-flow dependencies according to the definitions and calculation methods [9, 11] to reduce the concurrent program itself. Then, we translate the program slice to a traditional CPN model [21] (There is an example in Fig. 2(d)) and verified by the same model checking tool *EnPAC* [33] to compare with our method. In this way, there exist the model conversions mentioned above. This *PS* method have also been implemented on the same tool *DAMER*.

We evaluate *DMAER* efficiency and effectiveness to answer the following questions:

Q1: Are the unified model and on-demand slicing methods based on PDNet efficient?

Q2: Is our verification method based on our PDNet slice effective?

¹<https://github.com/shirleylee03/damer/>

Table 2: Slice Comparison of *PS* method and *PDNet* method

\mathcal{P}	ψ	<i>PS</i> method					<i>PDNet</i> method			
		S_{dfd}	S_{cfd}	S_{tra}	S_{pro}	M_{pro}	T_{pro}	M_{pdn}	S_{pdn}	T_{pdn}
Fib	ψ_1	1.334	18.183	0.301	19.818	1.578	21.396	2.240	0.744	2.984
	ψ_2	1.280	17.510	0.331	19.121	0.931	20.052	2.298	0.324	2.622
Lamport	ψ_1	2.006	165.664	0.578	168.248	2.552	170.800	4.201	1.610	5.811
	ψ_2	1.968	165.432	0.854	168.254	2.257	170.511	4.209	1.504	5.712
Dekker	ψ_1	1.428	64.792	0.430	66.650	1.949	68.599	3.213	1.286	4.499
	ψ_2	1.443	64.299	0.535	66.277	1.520	67.797	3.196	1.033	4.230
Szymanski	ψ_1	1.745	449.599	0.966	452.311	2.608	454.918	4.115	1.439	5.554
	ψ_2	1.750	448.491	1.174	451.415	1.982	453.397	4.149	1.363	5.512
Peterson	ψ_1	1.282	40.541	0.252	42.075	1.577	43.652	2.675	1.109	3.783
	ψ_2	1.317	40.171	0.340	41.828	1.200	43.028	2.585	0.836	3.421
Sync	ψ_1	1.757	14.505	0.342	16.605	1.265	17.870	1.838	0.743	2.581
	ψ_2	1.725	14.545	0.679	16.949	1.146	18.095	1.817	0.728	2.545
Datarace	ψ_1	1.869	51.096	0.415	53.380	2.056	55.436	3.114	0.962	4.076
	ψ_2	1.886	51.024	0.782	53.693	1.872	55.564	3.145	1.010	4.155
Rwlock	ψ_1	1.836	32.237	0.869	34.942	2.304	37.246	3.022	1.475	4.497
	ψ_2	1.847	31.838	0.934	34.619	1.895	36.514	3.051	1.393	4.444
Varmutex	ψ_1	1.730	29.709	0.675	32.114	3.464	35.578	4.598	1.648	6.245
	ψ_2	1.703	29.633	0.702	32.038	3.044	35.082	4.690	2.037	6.727
Lazy	ψ_1	1.620	11.914	0.232	13.766	1.356	15.122	1.784	0.754	2.538
	ψ_2	1.662	12.014	0.421	14.097	1.035	15.132	1.785	0.733	2.518
Average value		1.659	87.659	0.59	89.909	1.879	91.789	3.086	1.136	4.222

6.2 Slice Comparison

To confirm the advantages in the unified model and on-demand slicing of our PDNet methods of $Q1$, we report the concrete slicing time.

In Table 2, S_{dfd} is the time of *PS* method to calculate the complete data-flow dependencies for PDG, S_{cfd} is the time of *PS* method to calculate the complete control-flow dependencies for PDG, and S_{tra} is the time of *PS* method to capture the transitive closure of PDG. Then, S_{pro} ($S_{dfd}+S_{cfd}+S_{tra}$) is the slicing time of *PS* method. M_{pro} is the modeling time of *PS* method to construct a CPN model for the program slice, and T_{pro} ($M_{pro}+S_{pro}$) is the whole time of *PS* method before model checking. As for *PDNet* method, M_{pdn} is the modeling time to construct the PDNet for the whole program, and S_{pdn} is the slicing time of *PDNet* method. Here, M_{pdn} includes the time to calculate the control-flow structure and control-flow dependencies, and S_{pdn}

Table 3: Optimization Performance of *PS* method and *PDNet* method

Programs	ψ	∇T	ΔS	∇W	ΔV
Fib	ψ_1	7.17	54.4%	1.42	65.33%
	ψ_2	7.65	79.9%	2.93	33.01%
Lamport	ψ_1	29.39	37.7%	5.03	52.69%
	ψ_2	29.85	46.7%	13.68	3.25%
Dekker	ψ_1	15.25	30.8%	5.23	35.48%
	ψ_2	16.03	47.8%	5.13	37.66%
Szymanski	ψ_1	81.91	46.9%	18.36	32.11%
	ψ_2	82.26	53.4%	30.53	10.12%
Peterson	ψ_1	11.54	27.7%	3.72	38.84%
	ψ_2	12.58	49.5%	3.63	40.55%
Sync	ψ_1	6.92	64.6%	2.39	15.06%
	ψ_2	7.11	69.7%	2.46	16.85%
Datarace	ψ_1	13.60	57.8%	1.16	25.35%
	ψ_2	13.37	62.1%	3.76	24.78%
Rwlock	ψ_1	8.28	45.5%	2.01	34.93%
	ψ_2	8.22	49.9%	2.30	35.55%
Varmutex	ψ_1	5.70	31.5%	2.41	51.79%
	ψ_2	5.21	15.3%	3.13	47.86%
Lazy	ψ_1	5.96	59.3%	2.32	47.48%
	ψ_2	6.01	64.8%	2.32	7.58%
Average value		18.70	49.8%	5.70	32.81%

includes the time to capture the data-flow dependencies as well as the transitive closure of PDNet. T_{pdn} ($M_{pdn} + S_{pdn}$) is the whole time of *PDNet* method before model checking. The average values for all time are on the last row.

As we can see from Table 2, $T_{pro} > T_{pdn}$ for all program executions. The average of T_{pro} and T_{pdn} is 91.789 and 4.222, respectively. It implies the efficiency of our whole methods by the unified model and on-demand slicing. To show the optimization effect of *PDNet* method quantitatively, we calculate the reduction multiple ∇T by T_{pro}/T_{pdn} in Table 3, and the average of ∇T is 18.7. Here, 10 executions reduce the whole time by more than 10 times, and 4 executions reduce the whole time by more than 30 times. It can be concluded that our *PDNet* method can benefit against the calculating costs of the conversions between multiple irreplaceable models.

Moreover, $S_{dfd} + S_{tra}$ of *PS* method, including the calculating time of the data-flow dependencies and the transitive closure, corresponds to S_{pdn} of *PDNet* method. Thus, we calculate the reduction ratio ΔS by $(S_{dfd} + S_{tra} - S_{pdn}) / (S_{dfd} + S_{tra})$ in Table 3. It's obvious that $S_{dfd} + S_{tra} < S_{pdn}$

holds for each program execution, and the average of ΔS is 49.8%. The data-dependencies calculating time of 9 executions reduces more than 50%. The reason is that only when the variable is added to the PDNet slice, shall the data-flow dependencies of this variable be calculated. It can be concluded that our *PDNet* method can benefit against the calculating costs of the data-flow dependencies of irrelevant variables.

However, $M_{pdn} > M_{pro}$ holds for each execution. The average of M_{pdn} and M_{pro} are 1.879 and 3.086, respectively. Their difference is only 1.207 actually. Because PDNet is translated from the whole program and CPN is translated from the program slice, and there are some additional places and arcs to represent the control-flow dependencies. In fact, they don't have a major impact on the whole time.

To sum up, since the calculating costs in model conversions and irrelevant variables' data-flow dependencies are saved, our methods of the unified model and on-demand slicing based on PDNet are efficient.

6.3 Verification Comparison

To confirm the verifications of *PS* method and *PDNet* method in Table 2 for Q2, we report the verifying time and verifying results in Table 4.

In Table 4, V_{pro} is the time of *PS* method for verifying the program slice's CPN model, W_{pro} ($T_{pro} + V_{pro}$) is the whole time of *PS* method, and R_{pro} is the verifying result of *PS* method. Then, V_{pdn} is the time of *PDNet* method for verifying the PDNet slice, W_{pdn} ($T_{pdn} + V_{pdn}$) is the whole time of *PDNet* method, and R_{pdn} is the verifying result of *PDNet* method. Moreover, V_{opdn} is the time of *PDNet* method for verifying the original PDNet without slicing.

As we can see from Table 4, R_{pro} and R_{pdn} are both the correct verifying results for each formula. It implies that our methods are correct and effective.

To show the optimization effect of *PDNet* method quantitatively, we calculate the reduction multiple by ∇W by W_{pro}/W_{pdn} in Table 3. $W_{pro} > W_{pdn}$ holds for each program execution by ∇W . And the average of ∇W is 5.7. As for traditional program slicing method, it may take much time to calculate the domination relationship for the control-flow dependencies [9].

When verifying the original PDNet, it's obvious that $V_{opdn} > V_{pdn}$ holds for each program execution. To show the effect of PDNet slicing compared with original PDNet, we calculate the reduction ratio ΔV by $(M_{pdn} + V_{opdn}) - W_{pdn} / (M_{pdn} + V_{opdn})$ in Table 3 for each program execution, and the average of ΔV is 32.81%. It's obvious that our PDNet slicing can reduce the verifying time. The reason is that it could reduce the number of places, transitions and explored states of the original PDNet.

At the same time, the time for modeling (M_{pdn}) and the time for slicing (S_{pdn}) take very little time compared with V_{pdn} . Therefore, the reduction effect and usefulness of our PDNet slice are validated.

Table 4: Verification Comparison of *PS* method and *PDNet* method

\mathcal{P}	ψ	<i>PS</i> method			<i>PDNet</i> method			
		V_{pro}	W_{pro}	R_{pro}	V_{pdn}	W_{pdn}	R_{pdn}	V_{opdn}
Fib	ψ_1	14931.152	14952.548	<i>false</i>	10544.388	10547.373	<i>false</i>	30417.593
	ψ_2	9.686	29.738	<i>false</i>	7.511	10.133	<i>false</i>	12.910
Lamport	ψ_1	38.590	209.390	<i>true</i>	35.822	41.632	<i>true</i>	83.834
	ψ_2	8.075	178.586	<i>false</i>	7.339	13.051	<i>false</i>	9.234
Dekker	ψ_1	13.782	82.381	<i>true</i>	11.251	15.750	<i>true</i>	21.050
	ψ_2	12.810	80.607	<i>true</i>	11.489	15.718	<i>true</i>	21.902
Szymanski	ψ_1	27.037	481.956	<i>true</i>	20.703	26.257	<i>true</i>	34.450
	ψ_2	9.968	463.365	<i>false</i>	9.666	15.178	<i>false</i>	12.727
Peterson	ψ_1	12.695	56.347	<i>true</i>	11.344	15.127	<i>true</i>	22.097
	ψ_2	11.689	54.717	<i>true</i>	11.634	15.055	<i>true</i>	22.698
Sync	ψ_1	8.409	26.279	<i>true</i>	8.415	10.997	<i>true</i>	11.113
	ψ_2	8.657	26.753	<i>true</i>	8.346	10.891	<i>true</i>	11.292
Datarace	ψ_1	8009.776	8065.212	<i>true</i>	6947.670	6951.747	<i>true</i>	9309.458
	ψ_2	17.369	72.933	<i>false</i>	15.225	19.380	<i>false</i>	22.524
Rwlock	ψ_1	40.028	77.273	<i>true</i>	33.947	38.444	<i>true</i>	56.030
	ψ_2	52.972	89.486	<i>true</i>	34.491	38.934	<i>true</i>	57.393
Varmutex	ψ_1	45.990	81.569	<i>true</i>	27.537	33.782	<i>true</i>	65.494
	ψ_2	82.718	117.800	<i>true</i>	30.926	37.653	<i>true</i>	67.667
Lazy	ψ_1	11.292	26.414	<i>false</i>	8.857	11.395	<i>false</i>	19.889
	ψ_2	8.074	23.206	<i>false</i>	7.465	9.983	<i>false</i>	9.034
Average value		1168.038	1259.827	/	889.701	893.924	/	2014.419

7 Conclusion

In this paper, we proposed PDNet as the unified model to represent the control-flow structure with dependencies to save the calculating costs of the model conversions between multiple irreplaceable models. Based on the concurrent program semantics, we proposed how to model the dependencies of concurrent program with POSIX threads in PDNet. Then, we proposed an on-demand PDNet slicing method to reduce the scope of model checking, whose data-flow dependencies are captured for the variables related to the verified $LTL-X$. Thus, the costs from model conversions between multiple models and the complete calculation for the data-flow dependencies are saved by our methods. We implemented an automatic concurrent program model checking tool *DAMER* based on PDNet for $LTL-X$ formulae, and the experiments show the encouraging results of our methods.

Based on the current work, we will add the heuristic information from the dependencies information to help find counterexample paths for LTL_X formulae as quickly as possible during exploration, and integrate partial order methods (e.g., partial order reduction or Unfolding) to reduce possible interleavings from the independent threads for PDNet.

Supplementary information The experimental data is the first supplementary, and their features are described in Section 6.1.

The released version of our tool is the second supplementary for reproducing our experiments. Readme is the guideline to run our tool, including the running environment, the guidelines for the dependency package installation and the running script. The experimental data is in the test folder. Running the script in the build folder can automatically reproduce our experiments.

The complete original result including 10 run is the third supplementary.

Acknowledgments The authors would like to thank Zheng Huang for the invaluable suggestions in the experimental evaluation.

This work is partially supported by National Key Research and Development Program of China under Grant No.2018YFB2100801 and National Natural Science Foundation of China under Grant No.61672381.

Declarations

- Competing interests: The authors have no relevant financial or non-financial interests to disclose.
- Ethics approval: Not applicable.
- Consent to participate: Not applicable.
- Consent for publication: Not applicable.
- Availability of data and materials: The datasets generated and analysed during the current study are available in the Github repository, <https://github.com/shirleylee03/damer/tree/linux/test>.
- Code availability: The source code of the tool in this manuscript is available from <https://github.com/shirleylee03/damer/>.
- Authors' contributions: Methodology, Writing - Reviewing and Editing and Supervision were performed by Zhijun Ding; Conceptualization, Formal analysis and Writing - Original draft preparation were performed by Shuo Li; Software, Validation and Investigation were performed by Cheng Chen and Cong He. All authors read and approved the final manuscript.

Appendix A Concurrent Program Semantics

To express the operational semantics of a concurrent program for our PDNet modeling, we define the labeled transition system (LTS) semantics of the concurrent programs based on Definition 7 and Table. 1.

Definition 21 (LTS Semantics of Concurrent Programs) Let \mathcal{P} be a concurrent program, $\mathcal{N}_{\mathcal{P}} ::= \langle \mathcal{S}, \mathcal{A}, \rightarrow \rangle$ be the labeled transition system of \mathcal{P} , where:

1. $\mathcal{S} \subseteq \mathcal{H} \times \mathcal{M} \times (\mathcal{L} \rightarrow \mathcal{I}) \times (\mathcal{C} \rightarrow \mathcal{I}_{MS})$ is a set of the program configurations.

2. $\mathcal{A} \subseteq \mathcal{T} \times \mathcal{B}$ is a set of actions, where \mathcal{T} comes from \mathcal{P} .
3. $\rightarrow \subseteq \mathcal{S} \times \mathcal{A} \times \mathcal{S}$ is a set of transition relations on the program configurations \mathcal{S} .

Formally, $s ::= \langle h, m, r, u \rangle$ is a configuration of \mathcal{S} , where $h \in \mathcal{H}$ is a function that indicates the current program location of every thread, $m \in \mathcal{M}$ is the current memory state, r is a function that maps every mutex to a thread identifier, and u is also a function maps every condition variable to a multiset of thread identifiers of those threads that currently wait on that condition variable. $\mathcal{S}_0 ::= \langle h_0, m_0, r_0, u_0 \rangle$ where $h_0 \in \mathcal{H}$ and $m_0 \in \mathcal{M}$ come from \mathcal{P} , $r_0: \mathcal{L} \rightarrow \{0\}$ represents every mutex is not initially held by any threads, and $u_0: \mathcal{C} \rightarrow \emptyset$ represents every condition variable do not initially block any threads. Hence, we characterize the states of \mathcal{P} by the configurations \mathcal{S} of $\mathcal{N}_{\mathcal{P}}$. $\alpha ::= \langle \tau, \beta \rangle$ is an action of \mathcal{A} , where $\tau \in \mathcal{T}$ is a statement of \mathcal{P} and $\beta \in \mathcal{B}$ is an effect for the operation q from the statement τ . The transition relation \rightarrow on the configurations is represented by $s \xrightarrow{\langle \tau, \beta \rangle} s'$. The interleaved execution of τ could update the configuration s to a new configuration s' based on the effect β corresponding to the operation of τ . In fact, the effect of an action $\alpha \in \mathcal{A}$ characterizes the nature of the transition relations with this action on configurations of $\mathcal{N}_{\mathcal{P}}$. The effect is defined by $\mathcal{B} := (\{ass, jum, ret, tcd, fcd, call, rets\} \times K) \cup (\{acq, rel\} \times \mathcal{L}) \cup (\{sig\} \times \mathcal{C}) \cup (\{wa_1, wa_2, wa_3\} \times \mathcal{C} \times \mathcal{L})$.

To formalize our PDNet modeling methods, the semantics of a concurrent program is expressed by the transition relations \rightarrow on the program configurations under a current configuration $s = \langle h, m, r, u \rangle$ of \mathcal{P} in Table A1. The intuition behind the semantics is how s updates based on the transition relations with the actions of \mathcal{A} . Thus, the execution of a statement gives rise to a transition relation in correspondence with the operation of the statement. For convenience, the action referenced later is denoted by an abbreviation at the end of each row in Table A1. For instance, *ass* represents the action $\langle \tau, \langle ass, l' \rangle \rangle$ where $\langle ass, l' \rangle$ is the effect corresponding to the operation of τ , updating the program location to l' . Here, suppose an assignment operation is $\nu := w$ in statement τ . $\llbracket w \rrbracket m$ denotes that the value evaluating by the expression w under the memory state m . And this value is assigned to the variable ν . Thus, $m' = m[\nu \mapsto \llbracket w \rrbracket m]$ denotes the new memory state where $m'(\nu) = \llbracket w \rrbracket m$ and $m'(y) = m(y)$ ($\forall y \in \mathcal{V}: y \neq \nu$).

In the same way, *jum* represents the action $\langle \tau, \langle jum, l' \rangle \rangle$ where the jump operation of τ is *break* or *continue*, updating the program location to l' . But *jum* doesn't update the memory state. *ret* represents the action $\langle \tau, \langle ret, l' \rangle \rangle$ where the jump operation of τ is *return*, updating the program location to l' . For a branching operation, *tcd* represents the action $\langle \tau, \langle tcd, l' \rangle \rangle$, where the boolean condition w of is evaluated by *true* (i.e., $\llbracket w \rrbracket m = true$), and *fcd* represents the action $\langle \tau, \langle fcd, l' \rangle \rangle$, where the boolean condition w is evaluated by *flase* (i.e., $\llbracket w \rrbracket m = flase$). Neither *tcd* nor *fcd* updates the memory state. And they update the program locations to different program locations l' . For a function call, *call* represents the action $\langle \tau, \langle call, l' \rangle \rangle$, where l' is the entry of the called function, and *rets* represents the action $\langle \tau, \langle rets, l' \rangle \rangle$, where l' is the

Table A1: Semantics of Concurrent Programs

$\tau := \langle i, q, l, l', m, m' \rangle \in \mathcal{T} \quad q := \nu := w \quad h(i) = l$	(ass)
$\langle h, m, r, u \rangle \xrightarrow{\langle \tau, \langle ass, l' \rangle \rangle} \langle h[i \mapsto l'], m', r, u \rangle$	
$\tau := \langle i, q, l, l', m, m' \rangle \in \mathcal{T} \quad q := break \text{ or } continue \quad h(i) = l$	(jum)
$\langle h, m, r, u \rangle \xrightarrow{\langle \tau, \langle jum, l' \rangle \rangle} \langle h[i \mapsto l'], m, r, u \rangle$	
$\tau := \langle i, q, l, l', m, m' \rangle \in \mathcal{T} \quad q := return \quad h(i) = l$	(ret)
$\langle h, m, r, u \rangle \xrightarrow{\langle \tau, \langle ret, l' \rangle \rangle} \langle h[i \mapsto l'], m', r, u \rangle$	
$\tau := \langle i, q, l, l', m, m' \rangle \in \mathcal{T} \quad q := if(w) \text{ or } while(w) \quad \llbracket w \rrbracket = true \quad h(i) = l$	(tcd)
$\langle h, m, r, u \rangle \xrightarrow{\langle \tau, \langle tcd, l' \rangle \rangle} \langle h[i \mapsto l'], m, r, u \rangle$	
$\tau := \langle i, q, l, l', m, m' \rangle \in \mathcal{T} \quad q := if(w) \text{ or } while(w) \quad \llbracket w \rrbracket = false \quad h(i) = l$	(fcd)
$\langle h, m, r, u \rangle \xrightarrow{\langle \tau, \langle fcd, l' \rangle \rangle} \langle h[i \mapsto l'], m, r, u \rangle$	
$\tau := \langle i, q, l, l', m, m' \rangle \in \mathcal{T} \quad q := call \quad h(i) = l$	$(call)$
$\langle h, m, r, u \rangle \xrightarrow{\langle \tau, \langle call, l' \rangle \rangle} \langle h[i \mapsto l'], m', r, u \rangle$	
$\tau := \langle i, q, l, l', m, m' \rangle \in \mathcal{T} \quad q := rets \quad h(i) = l$	$(rets)$
$\langle h, m, r, u \rangle \xrightarrow{\langle \tau, \langle rets, l' \rangle \rangle} \langle h[i \mapsto l'], m', r, u \rangle$	
$\tau := \langle i, q, l, l', m, m' \rangle \in \mathcal{T} \quad q := (lock, \ell) \quad h(i) = l \quad r(\ell) = 0$	(acq)
$\langle h, m, r, u \rangle \xrightarrow{\langle \tau, \langle acq, \ell \rangle \rangle} \langle h[i \mapsto l'], m, r[\ell \mapsto i], u \rangle$	
$\tau := \langle i, q, l, l', m, m' \rangle \in \mathcal{T} \quad q := (unlock, \ell) \quad h(i) = l \quad r(\ell) = i$	(rel)
$\langle h, m, r, u \rangle \xrightarrow{\langle \tau, \langle rel, \ell \rangle \rangle} \langle h[i \mapsto l'], m, r[\ell \mapsto 0], u \rangle$	
$\tau := \langle i, q, l, l', m, m' \rangle \in \mathcal{T} \quad q := (signal, \gamma) \quad h(i) = l \quad \{j\} \in u(\gamma)$	(sig)
$\langle h, m, r, u \rangle \xrightarrow{\langle \tau, \langle sig, \gamma \rangle \rangle} \langle h[i \mapsto l'], m, r, u[\gamma \mapsto u(\gamma) \setminus \{j\} \cup \{-j\}] \rangle$	
$\tau := \langle i, q, l, l', m, m' \rangle \in \mathcal{T} \quad q := (wait, \gamma, \ell) \quad h(i) = l \quad r(\ell) = i \quad \{i\} \notin u(\gamma)$	(wa_1)
$\langle h, m, r, u \rangle \xrightarrow{\langle \tau, \langle wa_1, \gamma, \ell \rangle \rangle} \langle h, m, r[\ell \mapsto 0], u[\gamma \mapsto u(\gamma) \cup \{i\}] \rangle$	
$\tau := \langle i, q, l, l', m, m' \rangle \in \mathcal{T} \quad q := (wait, \gamma, \ell) \quad h(i) = l \quad r(\ell) = 0 \quad \{-i\} \in u(\gamma)$	(wa_2)
$\langle h, m, r, u \rangle \xrightarrow{\langle \tau, \langle wa_2, \gamma, \ell \rangle \rangle} \langle h, m, r, u[\gamma \mapsto u(\gamma) \setminus \{-i\}] \rangle$	
$\tau := \langle i, q, l, l', m, m' \rangle \in \mathcal{T} \quad q := (wait, \gamma, \ell) \quad h(i) = l \quad r(\ell) = 0$	(wa_3)
$\langle h, m, r, u \rangle \xrightarrow{\langle \tau, \langle wa_3, \gamma, \ell \rangle \rangle} \langle h[i \mapsto l'], m, r[\ell \mapsto i], u \rangle$	

return site of the calling function. Similarly, suppose *cassign* of *call* is $\nu_1 := w_1$ and *rassign* of *rets* is $\nu_2 := w_2$. $m' = m[\nu_1 \mapsto \llbracket w_1 \rrbracket m]$ denotes the new memory state for *call* and $m' = m[\nu_2 \mapsto \llbracket w_2 \rrbracket m]$ denotes the new memory state for *rets*. In addition, *ass*, *jum*, *tcd*, *fcd*, *call* and *rets* don't update *r* and *u* of *s*.

Moreover, *acq* represents the action $\langle \tau, \langle acq, \ell \rangle \rangle$ corresponding to the operation $\langle lock, \ell \rangle$. If ℓ is not held by any thread ($r(\ell) = 0$), *acq* represents thread *i* obtains this mutex ℓ ($r[\ell \mapsto i]$) and updates the program location to l' . However, if ℓ is held by other thread, thread *i* could be blocked by ℓ and current configuration *s* cannot be updated by *acq*. And *rel* represents the action $\langle \tau, \langle rel, \ell \rangle \rangle$ corresponding to the operation $\langle unlock, \ell \rangle$. Here, $r(\ell) = i$ means the mutex ℓ is held by thread *i*. If $r(\ell) = i$, thread *i* could release this mutex ℓ ($r[\ell \mapsto 0]$) and updates the program location to l' . Then, *sig* represents the action $\langle \tau, \langle sig, \gamma \rangle \rangle$ corresponding to the operation $\langle signal, \gamma \rangle$. Thread *i* could notify a thread *j* belonging to $u(\gamma)$ ($\{j\} \in u(\gamma)$). Thus, thread *j* could be notified by thread *i* ($u[\gamma \mapsto u(\gamma) \setminus \{j\} \cup \{-j\}]$). And it updates the program location to l' . Particularly, the operation $\langle wait, \gamma, \ell \rangle$ corresponds to three actions *wa*₁, *wa*₂ and *wa*₃, where only *wa*₃ updates the program location to l' . If the mutex ℓ is held by thread *i* ($r(\ell) = i$) and thread *i* is not waiting for γ currently ($\{i\} \notin u(\gamma)$), *wa*₁ ($\langle wa_1, \gamma, \ell \rangle$) represents the action releases the mutex ℓ ($r[\ell \mapsto 0]$), and thread *i* is added to the current thread multiset waiting on condition variable γ ($u[\gamma \mapsto u(\gamma) \cup \{i\}]$). Then, *wa*₂ ($\langle wa_2, \gamma, \ell \rangle$) represents the thread *i* is blocked

until a thread j ($\{-i\} \in u(\gamma)$) notifies by condition variable γ . Thus, thread i no long waits for a notification on γ ($u[\gamma \mapsto u(\gamma) \setminus \{-i\}]$). Finally, if the thread i has been woken up by the other thread and ℓ is not held ($r(\ell) = 0$), wa_3 ($\langle wa_3, \gamma, \ell \rangle$) represents the action acquires the mutex ℓ again ($r[\ell \mapsto i]$) and updates the program location to i . In addition, acq , rel , sig , wa_1 , wa_2 and wa_3 don't update m of the current configuration s .

References

- [1] Clarke EM, Henzinger TA, Veith H, Bloem R. Handbook of model checking. vol. 10. Springer; 2018.
- [2] Albert E, Gómez-Zamalloa M, Isabel M, Rubio A. Constrained Dynamic Partial Order Reduction. In: Computer Aided Verification. Cham: Springer International Publishing; 2018. p. 392–410. Available from: https://doi.org/10.1007/978-3-319-96142-2_24.
- [3] Weiser M. Program Slicing. IEEE Transactions on Software Engineering. 1984;SE-10(4):352–357. <https://doi.org/10.1109/TSE.1984.5010248>.
- [4] Hatcliff J, Dwyer M. Using the Bandera Tool Set to Model-Check Properties of Concurrent Java Software. In: CONCUR 2001 — Concurrency Theory. Springer Berlin Heidelberg; 2001. p. 39–58. Available from: https://doi.org/10.1007/3-540-44685-0_5.
- [5] Chalupa M, Vitovská M, Jašek T, Šimáček M, Strejček J. Symbiotic 6: generating test cases by slicing and symbolic execution. International Journal on Software Tools for Technology Transfer. 2021;23(6):875–877. <https://doi.org/10.1007/s10009-020-00573-0>.
- [6] Dwyer MB, Hatcliff J, Hoosier M, Ranganath V, Robby, Wallentine T. Evaluating the Effectiveness of Slicing for Model Reduction of Concurrent Object-Oriented Programs. In: Tools and Algorithms for the Construction and Analysis of Systems. Springer Berlin Heidelberg; 2006. p. 73–89. Available from: https://doi.org/10.1007/11691372_5.
- [7] Chalupa M, Strejček J. Evaluation of Program Slicing in Software Verification. In: Integrated Formal Methods. Cham: Springer International Publishing; 2019. p. 101–119. Available from: https://doi.org/10.1007/978-3-030-34968-4_6.
- [8] Kumar N, Neema S, Das M, Mohan BR. Program Slicing Analysis with KLEE, DIVINE and Frama-C. In: 2021 26th International Conference on Automation and Computing (ICAC); 2021. p. 1–5. Available from: <https://doi.org/10.23919/ICAC50006.2021.9594142>.

- [9] Ferrante J, Ottenstein KJ, Warren JD. The Program Dependence Graph and Its Use in Optimization. *ACM Transactions on Programming Languages and Systems (TOPLAS)*. 1987 jul;9(3):319–349. <https://doi.org/10.1145/24039.24041>.
- [10] Horwitz S, Reps T, Binkley D. Interprocedural slicing using dependence graphs. *ACM Transactions on Programming Languages and Systems (TOPLAS)*. 1990;12(1):26–60. <https://doi.org/10.1145/989393.989419>.
- [11] Qi X, Jiang Z. Precise slicing of interprocedural concurrent programs. *Frontiers of Computer Science*. 2017;11:971–986. <https://doi.org/10.1007/s11704-017-6189-3>.
- [12] Hatcliff J, Corbett J, Dwyer M, Sokolowski S, Zheng H. A Formal Study of Slicing for Multi-threaded Programs with JVM Concurrency Primitives. In: *Static Analysis*. Berlin, Heidelberg: Springer Berlin Heidelberg; 1999. p. 1–18. Available from: https://doi.org/10.1007/3-540-48294-6_1.
- [13] Hatcliff J, Dwyer MB, Zheng H. Slicing Software for Model Construction. *Higher Order Symbol Comput*. 2000 dec;13(4):315–353. <https://doi.org/10.1023/A:1026599015809>.
- [14] Dong W, Wang J, Qi Z. Slicing Concurrent Programs for Model Checking. *Chinese Journal of Computer Science*. 2003;026(003):266–274.
- [15] Löwe S, Mandrykin M, Wendler P. CPAchecker with sequential combination of explicit-value analyses and predicate analyses. In: *International Conference on Tools and Algorithms for the Construction and Analysis of Systems*. Springer; 2014. p. 392–394. Available from: https://doi.org/10.1007/978-3-642-54862-8_27.
- [16] Beyer D, Henzinger TA, Jhala R, Majumdar R. The software model checker BLAST. *International Journal on Software Tools for Technology Transfer*. 2007;9:505–525. <https://doi.org/10.1007/s10009-007-0044-z>.
- [17] Murata T. Petri nets: Properties, analysis and applications. *Proceedings of the IEEE*. 1989;77(4):541–580. <https://doi.org/10.1109/5.24143>.
- [18] Wolf K. How Petri Net Theory Serves Petri Net Model Checking: A Survey. In: *Transactions on Petri Nets and Other Models of Concurrency XIV*. Springer; 2019. p. 36–63. Available from: https://doi.org/10.1007/978-3-662-60651-3_2.
- [19] Kahlon V, Gupta A. An Automata-Theoretic Approach for Model Checking Threads for LTL Propert. In: *Proceedings of the 21st Annual IEEE Symposium on Logic in Computer Science*. LICS '06. USA: IEEE Computer Society; 2006. p. 101–110. Available from: <https://doi.org/10.1109/>

LICS.2006.11.

- [20] Jensen K, Kristensen LM. Formal Definition of Non-hierarchical Coloured Petri Nets. In: Coloured Petri Nets. Springer; 2009. p. 79–94. Available from: https://doi.org/10.1007/b95112_4.
- [21] Westergaard M. Verifying parallel algorithms and programs using coloured petri nets. In: Transactions on Petri Nets and Other Models of Concurrency VI. Springer; 2012. p. 146–168. Available from: https://doi.org/10.1007/978-3-642-35179-2_7.
- [22] Gan M, Wang S, Ding Z, Zhou M, Wu W. An Improved Mixed-Integer Programming Method to Compute Emptiable Minimal Siphons in S³PR Nets. IEEE Transactions on Control Systems Technology. 2018;26(6):2135–2140. <https://doi.org/10.1109/TCST.2017.2754982>.
- [23] Dietsch D, Heizmann D Matthiasand Klumpp, Naouar M, Podelski A, Schätzle C. Verification of Concurrent Programs Using Petri Net Unfoldings. In: Verification, Model Checking, and Abstract Interpretation. Cham: Springer International Publishing; 2021. p. 174–195. Available from: https://doi.org/10.1007/978-3-030-67067-2_9.
- [24] He C, Ding Z. More Efficient On-the-Fly Verification Methods of Colored Petri Nets. COMPUTING AND INFORMATICS. 2021 Aug;40(1):195–215. https://doi.org/10.31577/cai_2021_1_195.
- [25] Barney B.: POSIX Threads Programming. <https://hpc-tutorials.llnl.gov/posix/>.
- [26] Gastin P, Oddoux D. Fast LTL to Büchi Automata Translation. In: Computer Aided Verification. Berlin, Heidelberg: Springer Berlin Heidelberg; 2001. p. 53–65. Available from: https://doi.org/10.1007/3-540-44585-4_6.
- [27] Masud AN, Lisper B. Semantic Correctness of Dependence-Based Slicing for Interprocedural, Possibly Nonterminating Programs. ACM Trans Program Lang Syst. 2021 jan;42(4). <https://doi.org/10.1145/3434489>.
- [28] Kavi KM, Moshtaghi A, Chen DJ. Modeling Multithreaded Applications Using Petri Nets. Int J Parallel Program. 2002 oct;30(5):353–371. <https://doi.org/10.1023/A:1019917329895>.
- [29] Reps T, Yang W. The semantics of program slicing and program integration. In: TAPSOFT '89. Springer Berlin Heidelberg; 1989. p. 360–374. Available from: https://doi.org/10.1007/3-540-50940-2_47.

- [30] Barraclough RW, Binkley D, Danicic S, Harman M, Hierons RM, Ákos Kiss, et al. A trajectory-based strict semantics for program slicing. *Theoretical Computer Science*. 2010;411(11):1372–1386. <https://doi.org/10.1016/j.tcs.2009.10.025>.
- [31] Krinke J. Advanced slicing of sequential and concurrent programs. In: 20th IEEE International Conference on Software Maintenance, 2004. Proceedings. IEEE; 2004. p. 464–468. Available from: <https://doi.org/10.1109/ICSM.2004.1357836>.
- [32] Peled D, Wilke T. Stutter-invariant temporal properties are expressible without the next-time operator. *Information Processing Letters*. 1997 sep;63(5):243–246. [https://doi.org/10.1016/S0020-0190\(97\)00133-6](https://doi.org/10.1016/S0020-0190(97)00133-6).
- [33] Ding Z, He C, Li S, Huang Q.: EnPAC. <http://www.enpac.top/>.