

Byzantine Multiple Access Channels — Part I: Reliable Communication*

Neha Sangwan¹, Mayank Bakshi², Bikash Kumar Dey³, and Vinod M. Prabhakaran¹

¹Tata Institute of Fundamental Research, Mumbai, India

²Arizona State University, Tempe, AZ, USA

³Indian Institute of Technology Bombay, Mumbai, India

November 24, 2022

Abstract

We study communication over a Multiple Access Channel (MAC) where users can possibly be adversarial. When all users are non-adversarial, we want their messages to be decoded reliably. When a user behaves adversarially, we require that the honest users' messages be decoded reliably. An adversarial user can mount an attack by sending any input into the channel rather than following the protocol. It turns out that the 2-user MAC capacity region follows from the point-to-point Arbitrarily Varying Channel (AVC) capacity. For the 3-user MAC in which at most one user may be malicious, we characterize the capacity region for deterministic codes and randomized codes (where each user shares an independent random secret key with the receiver). These results are then generalized for the k -user MAC where the adversary may control all users in one out of a collection of given subsets.

1 Introduction

1.1 Motivation and setup

Communication systems such as the wireless Internet-of-Things (IoTs), which consist of devices of varying security levels connected over a wireless network, pose new security challenges [2, 3]. Since, the devices share the same communication medium, a malicious¹ device may attempt to cause decoding errors for the honest device(s). This motivates the present problem. We study the uplink of a communication network in which users may behave maliciously.

Consider a Multiple Access Channel (MAC) with users who are potentially adversarial. An adversarial user may not follow the protocol and may choose its channel input maliciously to disrupt the communication of the other users. We call such a channel a “byzantine-MAC”. If all users are non-adversarial (i.e., honest), we require that their messages be reliably decoded. However, if some of the users are adversarial, the decoder must correctly recover the messages of all the other (honest) users. We call this the problem of *reliable communication in a byzantine-MAC*.

*This work was presented in part at the IEEE Information Theory Workshop, 2019 [1].

N. Sangwan and V. M. Prabhakaran were supported by DAE under project no. RTI4001. N. Sangwan was additionally supported by the TCS Foundation through the TCS Research Scholar Program. The work of M. Bakshi was supported in part by the Research Grants Council of the Hong Kong Special Administrative Region, China, under Grant GRF 14300617, and in part by the National Science Foundation under Grant No. CCF-2107526. The work of B. K. Dey was supported by Bharti Centre for Communication in IIT Bombay. V. M. Prabhakaran was additionally supported by SERB through project MTR/2020/000308.

¹We use ‘malicious’ and ‘adversarial’ interchangeably.

1.2 Related works

The present model is different from other well-studied models involving *external adversaries*, both *passive* and *active*. For example, a wiretap channel [4] has a passive eavesdropper who gets a noisy version of the communication between the sender and the receiver. The goal is to ensure reliable and private (from the eavesdropper) communication from the sender to the receiver. On the other hand, in arbitrarily varying channels (AVC) [5, 6] the external adversary is active and controls the channel. The adversary can change the channel law for each channel use with the goal of jamming the communication between the sender and the receiver. Arbitrarily varying multiple access channels (AV-MAC) [7–12], which consider a Multiple Access Channel (MAC) where the channel law is controlled by an external adversary, have also been studied. Jahn [8] obtained the randomized coding capacity region where each user has independent randomness shared with the receiver. He also showed that this region is also the deterministic coding capacity region under average probability of error whenever the latter has a non-empty interior, a result along the lines of Ahlswede’s dichotomy for the AVC [13]. Gubner [9] proved necessary conditions (non-symmetrizability conditions) for the deterministic coding capacity region to be non-empty. Ahlswede and Cai [10] showed that Gubner’s necessary conditions are also sufficient for the deterministic coding capacity region to have a non-empty interior. More recently, Pereg and Steinberg [11] obtained the capacity region for the AV-MAC with state constraints. Wiese and Boche [12] considered the two-user AV-MAC with conferencing encoders. In a recent work, Beemer, Graves, Kliever, Kosut, and Yu [7] considered an authentication like model in a two-user AV-MAC, where all states, except one, are treated as adversarial states. Under adversarial states, the decoder’s output can be a declaration of the presence of an adversary while also decoding at least one user’s message.

In contrast to these works, the current model has *internal adversaries*, i.e., one of the legitimate users is potentially adversarial. There are other works on *internal adversaries* in the information theory literature, mostly in the setting of network coding. Byzantine attacks on the nodes and edges of networks have been studied under omniscient and weaker adversarial models in [14] and [15, 16], respectively. He and Yener [17] considered a Gaussian two-hop network with an eavesdropping and byzantine adversarial relay where the requirement is decoding the message with secrecy and byzantine attack detection. La and Anantharam [18] studied the MAC with strategic users modeled as a cooperative game with the objective of fairly allocating communication rate among the users.

For the byzantine-MAC, in a previous work [19], we looked at a weaker decoding guarantee than the present model, called *authenticated communication*. The goal was to ensure reliable decoding when all users are non-adversarial. However, if any user behaves adversarially, the decoder (with high probability) must either output the correct messages for the honest users or declare error, i.e., an adversary should not be able to cause an undetected erroneous output for the honest users. In the slightly stronger model of *communication with adversary identification* [20] in a byzantine-MAC, we considered a decoding guarantee similar to [19], except that the decoder is required to identify the malicious user(s) while declaring error.

1.3 Two-user byzantine-MAC

For the 2-user byzantine-MAC, consider the problem of reliable communication when any one of the users might be adversarial (though the decoder does not know *a priori* which, if any, of the users is adversarial). Clearly, each user can at least achieve the capacity of the AVC where the other user’s input is treated as the channel state. Further, it is also easy to see that no higher rate is possible as, for the honest user’s perspective, the other user, when adversarial, can behave exactly like an adversary in the AVC setup (see Figure 1(a) and (b)). Thus, the capacity region is the rectangular region defined by the AVC capacities of the two users’ channels (Figure 1(c)), *i.e.*, there is no trade-off between the rates². Thus, the simplest non-trivial case is that of a 3-user byzantine-MAC with at most one adversarial user.

²This observation holds true under deterministic coding, stochastic encoding (where the encoders have private randomness), and randomized coding settings under both maximum and average probabilities of error. A similar observation can be made for a k -user byzantine-MAC where up to $k - 1$ users may adversarially collude.

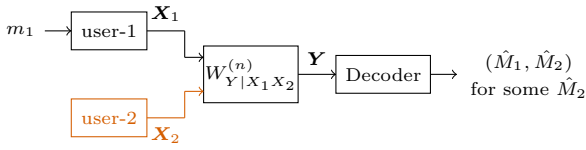

(a) A two-user byzantine-MAC where user-2 is malicious.

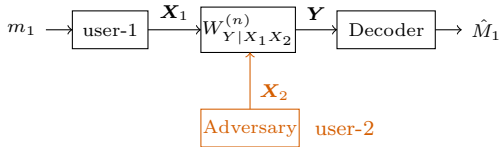

(b) A malicious user-2 can simulate an AVC from user-1 to the receiver where the input of user-2 is treated as the adversarial state. Thus, user-1 cannot communicate reliably an any rate above the capacity of this AVC. On the other hand, user-1 can achieve all the rates below the capacity of this AVC by using an appropriate AVC code.

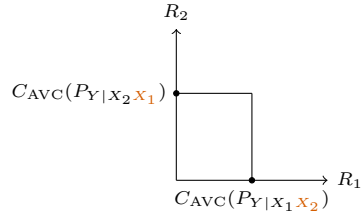

$$\text{where } C_{\text{AVC}}(P_{Y|X_1X_2}) = \max_{P_{X_1}} \min_{P_{X_2}} I(X_1; Y)$$

$$C_{\text{AVC}}(P_{Y|X_2X_1}) = \max_{P_{X_2}} \min_{P_{X_1}} I(X_2; Y)$$

(c) Capacity region of a two-user byzantine-MAC.

Figure 1: Capacity region of a two-user byzantine-MAC is given by the rectangular capacity region obtained by treating the channel from each user to the receiver as an AVC with the other user's input as the AVC state sequence.

1.4 Three-user byzantine-MAC

It turns out that all the key ideas can be presented in the relatively simpler setting of a 3-user byzantine-MAC with at most one adversarial user. The general results then build on this. For this model, we characterize the capacity region under randomized coding where each user shares independent secret keys with the decoder, and deterministic coding with an average probability of error criterion.

1.4.1 Randomized coding

Consider a three-user byzantine-MAC in which each user shares independent randomness with the decoder which is unknown to the other users. Notice that similar to the two-user byzantine-MAC where a malicious user could induce an AVC from the honest user to the receiver, in a three-user byzantine-MAC, a malicious user- i , $i \in \{1, 2, 3\}$ can induce a two-user AV-MAC $W^{(i)}$ from the honest users $\{1, 2, 3\} \setminus \{i\}$ to the receiver, where the input of the malicious user is treated as the adversarially chosen state sequence. For instance, if a rate triple (R_1, R_2, R_3) is achievable for the byzantine-MAC, then the rate pair (R_1, R_2) is also be achievable over the two-user AV-MAC $W^{(3)}$.³ We use this intuition to show the converse of the randomized coding capacity region (Theorem 3). We show the achievability by using a randomized code (from [8]⁴) for the two-user AV-MAC $W^{(i)}$, $i \in \{1, 2, 3\}$ and using random hashes for each message, generated using the independent shared randomness. See Section 3.2.2 for a sketch of achievability and Section 4.2 for a detailed proof of achievability and converse.

1.4.2 Deterministic coding

For deterministic coding, before discussing the capacity region, let us consider the following question: in which channels can all users *communicate reliably*?

In the AVC literature, the channels over which reliable communication is infeasible are called *symmetrizable channels* [21, 22]. In a symmetrizable AVC, the adversary can mount an attack which introduces a spurious message

³In fact, a stronger necessary condition follows by noting that the encoder of each user must not depend on the knowledge of which user, if any, is the adversary. Thus, as in compound channels, the same code should work for $W^{(i)}$, $i \in \{1, 2, 3\}$. We use this observation in our converse arguments.

⁴Note that similar to the current model, in the AV-MAC model of [8], users share independent randomness with the decoder.

that can be confused with the actual message, resulting in a non-vanishing probability of error.

To answer the question, we first recall that a malicious user- i , $i \in \{1, 2, 3\}$, in a three-user byzantine-MAC, can induce a two-user AV-MAC $W^{(i)}$ formed by treating user- i 's input as an adversarially chosen state and the inputs of other two users as the inputs of legitimate users in the two-user AV-MAC. Thus, we inherit the symmetrizability conditions [9, Definition 3.1-3.3] from the three AV-MAC $W^{(1)}$, $W^{(2)}$ and $W^{(3)}$. We show that, in addition to the symmetrizability conditions inherited from the AV-MAC, fully characterizing the feasibility of reliable communication of a 3-user byzantine-MAC requires three additional symmetrizability conditions (Eq. (7)). Roughly speaking, each of these conditions reflect whether or not an adversarial user at a node k can attack in a manner that is also consistent with an adversarial user at a node $j \neq k$ while resulting in a decoding ambiguity about the remaining user's message (see Figure 7). Example 1 (page 14) shows that the new symmetrizability conditions are not redundant given the symmetrizability conditions inherited from the two-user AV-MAC.

We characterize the deterministic coding capacity region under the average error criterion for most channels.⁵ There are two different approaches towards showing the achievability for the AVC using deterministic codes. We show achievability for the 3-user byzantine-MAC using both approaches and show a more general result for k -user byzantine-MAC using one of them.

First approach. The first approach uses a *randomness reduction* argument of Ahlswede [13] (and its extension for AV-MAC by Jahn [8]). He showed that given a randomized code of achievable rate R and block-length n , there exists another randomized code of achievable rate R which requires only $O(\log n)$ bits of randomness. This small amount of shared randomness can be established using deterministic codes. This shows the surprising fact that when the deterministic capacity is positive (which is the case for non-symmetrizable channels), it is in fact equal to the randomized coding capacity. Thus, to show achievability under deterministic codes, it suffices to show that all non-symmetrizable channels admit positive rates. Ahlswede and Cai in [10] took this route for the achievability proof of the two-user AV-MAC. For byzantine-MACs, we may follow a similar recipe (in fact, we do this for the general k -user byzantine-MAC). We show a *randomness reduction* argument along the lines of Jahn [8] and Ahlswede [13] (see Appendix E). With this and the randomized coding scheme discussed above (Section 1.4.1), all that remains is to show that in a non-symmetrizable byzantine-MAC, all users can transmit at positive rates using deterministic coding. The main difference from [10] in showing this, is that the code should be able to handle any user behaving maliciously. Please see Section 5 for details.

Second approach. The second approach is a direct argument based on the method of types which establishes a deterministic code. The technique does not rely on the achievability of the randomized coding capacity. For the (point-to-point) AVC, Csiszár and Narayan [22] established the deterministic coding capacity using such an approach. Their achievability proof is based on a concentration result [22, Lemma A1]. A similar approach for multi-user channels (e.g. AV-MAC, byzantine-MAC etc.) requires extending this concentration result. We specialize the concentration result in [23, Theorem 2.1] to obtain just such an extension (Lemma 4 on page 19). This allows us to directly achieve all rate triples in the capacity region of a non-symmetrizable three-user byzantine-MAC (see Section 4.1). Our technique can also be used to obtain the deterministic coding capacity region of a two-user AV-MAC directly. We believe that this technique may have applications in other multi-user deterministic coding settings for adversarial channels and may be of independent interest.

1.5 k -user byzantine-MAC

In Section 5, we consider a general k -user byzantine-MAC in which an adversary may control all users in any one of a set of subsets of users, called an *adversary structure*⁶ (see Fig. 2). The receiver is unaware which of these subsets the adversary controls. We provide a general symmetrizability condition for the k -user byzantine-MACs.

⁵Our characterization for deterministic codes is incomplete for channels in which some, but not all users are symmetrizable (for an appropriate notion of symmetrizability for a 3-user byzantine-MAC). See remark 2.

⁶The term 'adversary structure' is borrowed from cryptography. An adversary structure is a collection of subsets of users. The adversary may control all the users in any one of these subsets and use them to mount an attack (see, e.g., [24–26])

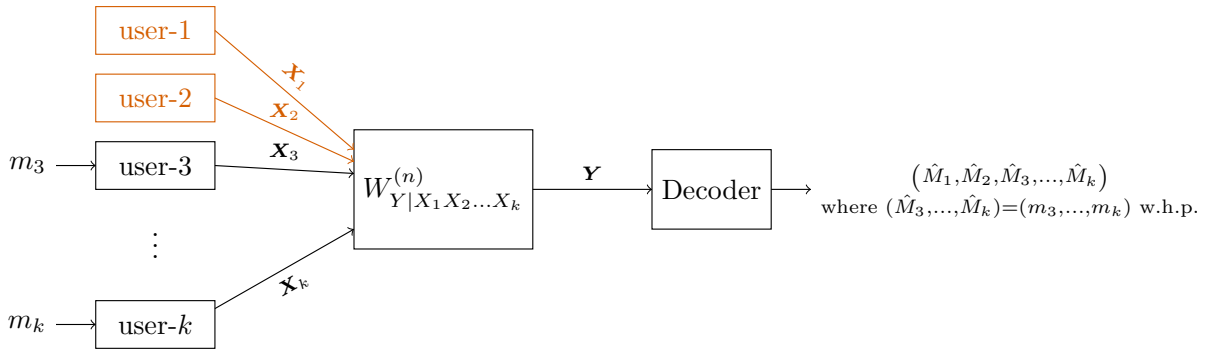

Figure 2: Reliable decoding in a byzantine-MAC: The figure depicts a k -user byzantine-MAC where user-1 and user-2 belong to the adversary structure and are controlled by the adversary. We require reliable decoding of all honest users' messages, which correspond to users 3 to k in this case.

On the achievability side, we take the first achievability approach described above (see Section 1.4.2) and show a *randomness reduction* argument along the lines of Jahn [8] and Ahlswede [13]. We then show that as long as the given byzantine-MAC is non-symmetrizable, i.e., none of the symmetrizability conditions hold, the deterministic coding capacity region has a non-empty interior, in other words, all users can communicate at positive rates. Finally, we characterize the randomized coding capacity region using the same ideas as that for the three-user case. For the k -user byzantine-MAC, we do not pursue a direct proof using the second achievability approach described above (in Section 1.4.2) as it appears to be cumbersome.

1.6 Summary of contributions

- We introduce the model of reliable communication in a byzantine-MAC, where malicious users may deviate from the prescribed protocol. The model requires that decoded messages should be correct for the honest users with high probability.
- We completely characterize the capacity region under both deterministic codes (with an average probability of error criterion) and randomized codes for any k -user byzantine-MAC.
- We also provide an alternate direct achievability for the 3-user byzantine-MAC, in the spirit of [22], where the achievability is based on a recent concentration result. This technique can be used to obtain a similar direct achievability for the 2-user AV-MAC (see Section 1.4.2) and may be of independent interest.

1.7 Outline

The system model and main results for the 3-user byzantine-MAC are given in Section 3 (Page 6). This section also contains the proof sketches. The main proofs of the results in Section 3 are given in Section 4 (page 17). Others are deferred to the appendices. Section 5 presents the k -user byzantine-MAC model and gives main results. All the proofs of theorems in this section are given in the appendices.

2 Notation

Random variables are denoted by capital letters (possibly indexed) like X_1, X_2, X_3, Y , etc. The corresponding alphabets are denoted by calligraphic letters in the same format, for example, the random variable X_1 has alphabet \mathcal{X}_1 . Its n -product set is denoted by \mathcal{X}_1^n . We use bold faced letters to denote n -length vectors, for example, \mathbf{x} denotes a vector in \mathcal{X}^n and \mathbf{X} denotes a random vector taking values in \mathcal{X}^n . For a random variable X , we denote its distribution by P_X and use the notation $X \sim P_X$ to indicate this. For an alphabet \mathcal{X} , let $\mathcal{P}_{\mathcal{X}}^n$ denote the set of all

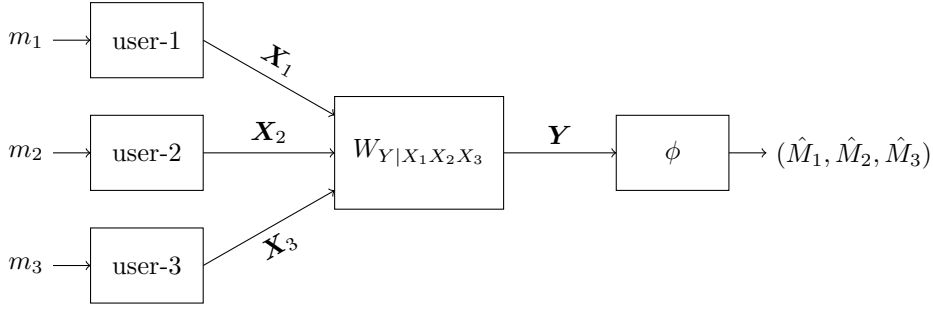

Figure 3: byzantine-MAC: At most one user may be adversarial. Reliable decoding of the messages of all honest users is required. Clearly, no decoding guarantees are given for an adversarial user.

empirical distributions of n length strings from \mathcal{X}^n . For a random variable $X \sim P_X$ such that $P_X \in \mathcal{P}_{\mathcal{X}}^n$, let T_X^n be the set of all n -length strings with empirical distribution P_X . For $\mathbf{x} \in \mathcal{X}^n$, the statement $\mathbf{x} \in T_X^n$ defines P_X as the empirical distribution of \mathbf{x} and a random variable $X \sim P_X$. For a set \mathcal{S} , $2^{\mathcal{S}}$ denotes its power set, \mathcal{S}^c denotes its complement and $\text{int}(\mathcal{S})$ denotes its interior. A uniform distribution on any set \mathcal{S} is denoted by $\text{Unif}(\mathcal{S})$. For any n , the set $\{1, 2, \dots, n\}$ will be denoted by $[1 : n]$. We will use the acronyms ‘w.h.p.’ to mean ‘with high probability’ and ‘TBD’ to mean ‘to be decided’.

The following notation will be used in Section 5. For any sets \mathcal{S}_i , $i \in [1 : k]$ and for $\mathcal{B} \subseteq [1 : k]$, $\mathcal{S}_{\mathcal{B}}$ denotes the product set $\times_{i \in \mathcal{B}} \mathcal{S}_i$. The tuple $(s_i \in \mathcal{S}_i : i \in [1 : k])$ will be denoted by $s_{[1:k]} \in \mathcal{S}_{[1:k]}$ and when restricted to \mathcal{B} , we write $s_{\mathcal{B}} \in \mathcal{S}_{\mathcal{B}}$. The notation $g_{\mathcal{B}}(s_{\mathcal{B}})$ denotes $(g_i(s_i) : i \in \mathcal{B})$ for function g_i defined on \mathcal{S}_i , $i \in [1 : k]$.

3 The three user byzantine-MAC

3.1 System model

Consider the 3-user byzantine-MAC setup shown in Fig. 3. The memoryless channel $W_{Y|X_1X_2X_3}$ has input alphabets $\mathcal{X}_1, \mathcal{X}_2, \mathcal{X}_3$, and output alphabet \mathcal{Y} .

Definition 1 (Deterministic code). An (N_1, N_2, N_3, n) deterministic *code* for the byzantine-MAC $W_{Y|X_1X_2X_3}$ consists of the following:

- (i) three message sets, $\mathcal{M}_i = \{1, \dots, N_i\}$, $i = 1, 2, 3$,
- (ii) three encoders, $f_i : \mathcal{M}_i \rightarrow \mathcal{X}_i^n$, $i = 1, 2, 3$, and
- (iii) a decoder, $\phi : \mathcal{Y}^n \rightarrow \mathcal{M}_1 \times \mathcal{M}_2 \times \mathcal{M}_3$.

We define the average probability of error P_e as the maximum of average error probabilities under four different scenarios, one corresponding to all users being honest and three corresponding to exactly one user being adversarial. Let $(\hat{M}_1, \hat{M}_2, \hat{M}_3) = \phi(Y^n)$.

$$P_e(f_1, f_2, f_3, \phi) \stackrel{\text{def}}{=} \max\{P_{e,0}, P_{e,1}, P_{e,2}, P_{e,3}\},$$

where the terms on the right-hand side are defined below. Note that our notation suppresses their dependence on the code. $P_{e,0}$ is the average probability of error when none of the users are adversarial,

$$P_{e,0} \stackrel{\text{def}}{=} \frac{1}{N_1 N_2 N_3} \sum_{(m_1, m_2, m_3) \in \mathcal{M}_1 \times \mathcal{M}_2 \times \mathcal{M}_3} e_0(m_1, m_2, m_3), \text{ where}$$

$$e_0(m_1, m_2, m_3) = \mathbb{P}\left((\hat{M}_1, \hat{M}_2, \hat{M}_3) \neq (m_1, m_2, m_3) \mid \mathbf{X}_1 = f_1(m_1), \mathbf{X}_2 = f_2(m_2), \mathbf{X}_3 = f_3(m_3)\right).$$

$P_{e,i}$, $i = 1, 2, 3$ is the average error probability under worst case deterministic attacks when user- i is adversarial. $P_{e,1}$ is as below. $P_{e,2}, P_{e,3}$ are defined similarly.

$$P_{e,1} \stackrel{\text{def}}{=} \max_{\mathbf{x}_1 \in \mathcal{X}_1^n} \frac{1}{N_2 N_3} \sum_{(m_2, m_3) \in \mathcal{M}_2 \times \mathcal{M}_3} e_1(\mathbf{x}_1, m_2, m_3), \text{ where}$$

$$e_1(\mathbf{x}_1, m_2, m_3) = \mathbb{P}\left((\hat{M}_2, \hat{M}_3) \neq (m_2, m_3) \mid \mathbf{X}_1 = \mathbf{x}_1, \mathbf{X}_2 = f_2(m_2), \mathbf{X}_3 = f_3(m_3)\right). \quad (1)$$

We emphasize that

- the decoder is unaware of whether any of the users is adversarial and the identity of the adversarial user (if any).
- the adversary knows the encoders and the decoder, but is unaware of the messages transmitted by the other (non-adversarial) users⁷.

Note that it is sufficient to define $P_{e,i}$ under deterministic attacks by the adversarial user. To see this, consider the setting where user-1 is adversarial. Then, under any randomized attack $\tilde{\mathbf{X}}_1 \sim Q$ for any distribution Q on \mathcal{X}_1^n ,

$$\begin{aligned} & \mathbb{E}_Q \left[\frac{1}{N_2 N_3} \sum_{m_2, m_3} \mathbb{P}\left((\hat{M}_2, \hat{M}_3) \neq (m_2, m_3) \mid \mathbf{X}_1 = \tilde{\mathbf{X}}_1, \mathbf{X}_2 = f_2(m_2), \mathbf{X}_3 = f_3(m_3)\right) \right] \\ &= \sum_{\mathbf{x}_1 \in \mathcal{X}_1^n} Q(\mathbf{x}_1) \frac{1}{N_2 N_3} \sum_{m_2, m_3} \mathbb{P}\left((\hat{M}_2, \hat{M}_3) \neq (m_2, m_3) \mid \mathbf{X}_1 = \mathbf{x}_1, \mathbf{X}_2 = f_2(m_2), \mathbf{X}_3 = f_3(m_3)\right) \\ &\leq \sum_{\mathbf{x}_1 \in \mathcal{X}_1^n} Q(\mathbf{x}_1) P_{e,1} \\ &= P_{e,1}. \end{aligned} \quad (2)$$

In other words, the probability of error is maximized when the adversarial user selects a deterministic attack vector (that depends only on the channel and the deterministic code used). We also note that

$$P_{e,0} \leq P_{e,1} + P_{e,2} + P_{e,3}. \quad (3)$$

This is because

$$\begin{aligned} P_{e,o} &= \frac{1}{N_1 N_2 N_3} \sum_{m_1, m_2, m_3} \mathbb{P}\left((\hat{M}_1, \hat{M}_2, \hat{M}_3) \neq (m_1, m_2, m_3) \mid \mathbf{X}_1 = f_1(m_1), \mathbf{X}_2 = f_2(m_2), \mathbf{X}_3 = f_3(m_3)\right) \\ &= \frac{1}{N_1 N_2 N_3} \sum_{m_1, m_2, m_3} \mathbb{P}\left(\{(\hat{M}_1, \hat{M}_2) \neq (m_1, m_2)\} \cup \{(\hat{M}_2, \hat{M}_3) \neq (m_2, m_3)\} \cup \{(\hat{M}_1, \hat{M}_3) \neq (m_1, m_3)\} \right. \\ &\quad \left. \mid \mathbf{X}_1 = f_1(m_1), \mathbf{X}_2 = f_2(m_2), \mathbf{X}_3 = f_3(m_3)\right) \\ &\leq \frac{1}{N_1 N_2 N_3} \sum_{m_1, m_2, m_3} \left\{ \mathbb{P}\left(\{(\hat{M}_1, \hat{M}_2) \neq (m_1, m_2)\} \mid \mathbf{X}_1 = f_1(m_1), \mathbf{X}_2 = f_2(m_2), \mathbf{X}_3 = f_3(m_3)\right) \right. \\ &\quad + \mathbb{P}\left(\{(\hat{M}_2, \hat{M}_3) \neq (m_2, m_3)\} \mid \mathbf{X}_1 = f_1(m_1), \mathbf{X}_2 = f_2(m_2), \mathbf{X}_3 = f_3(m_3)\right) \\ &\quad \left. + \mathbb{P}\left(\{(\hat{M}_1, \hat{M}_3) \neq (m_1, m_3)\} \mid \mathbf{X}_1 = f_1(m_1), \mathbf{X}_2 = f_2(m_2), \mathbf{X}_3 = f_3(m_3)\right) \right\} \\ &\leq P_{e,1} + P_{e,2} + P_{e,3}. \end{aligned}$$

⁷Recall that at most one user is adversarial.

Definition 2 (Achievable rate triple and the deterministic coding capacity region). We say a rate triple (R_1, R_2, R_3) is *achievable* if there is a sequence of $(\lfloor 2^{nR_1} \rfloor, \lfloor 2^{nR_2} \rfloor, \lfloor 2^{nR_3} \rfloor, n)$ codes $(f_1^{(n)}, f_2^{(n)}, f_3^{(n)}, \phi^{(n)})$ for $n = 1, 2, \dots$ such that $\lim_{n \rightarrow \infty} P_e(f_1^{(n)}, f_2^{(n)}, f_3^{(n)}, \phi^{(n)}) \rightarrow 0$. The *deterministic coding capacity region* $\mathcal{R}_{\text{deterministic}}$ is the closure of the set of all achievable rate triples.

Definition 3 (Randomized code). An (N_1, N_2, N_3, n) randomized *code* for the byzantine-MAC $W_{Y|X_1 X_2 X_3}$ consists of the following:

- (i) three message sets, $\mathcal{M}_i = \{1, \dots, N_i\}$, $i = 1, 2, 3$,
- (ii) three *independent* randomized encoders, $F_i : \mathcal{M}_i \rightarrow \mathcal{X}_i^n$ where $F_i \sim P_{F_i}$ takes values in $\mathcal{F}_i \subseteq \{g : \mathcal{M}_i \rightarrow \mathcal{X}_i^n\}$, $i = 1, 2, 3$ and
- (iii) a decoder, $\phi : \mathcal{Y}^n \times \mathcal{F}_1 \times \mathcal{F}_2 \times \mathcal{F}_3 \rightarrow \mathcal{M}_1 \times \mathcal{M}_2 \times \mathcal{M}_3$ where $\phi(\mathbf{y}, F_1, F_2, F_3) = (\phi_1(\mathbf{y}, F_1, F_2, F_3), \phi_2(\mathbf{y}, F_1, F_2, F_3), \phi_3(\mathbf{y}, F_1, F_2, F_3))$ for some deterministic functions $\phi_i : \mathcal{Y}^n \times \mathcal{F}_1 \times \mathcal{F}_2 \times \mathcal{F}_3 \rightarrow \mathcal{M}_i$, $i = 1, 2, 3$. The decoder ϕ is a deterministic map.

This is similar to the randomized code of Jahn [8] for 2-user AV-MACs. We emphasize that, as in [8], the random encoder maps F_1, F_2 are independent. Notice that the decoder ϕ is a function of the output as well as the random encoding maps. This allows the adversarial user to use its own random encoding map as a part of the attack. We will consider the natural setting where the adversarial user has access to its random encoding map while mounting an attack, but is unaware of the realizations of the other users' encoding maps. We call such an adversary a *standard* adversary and denote the *randomized coding capacity region* in this setting by $\mathcal{R}_{\text{random}}$. We also consider two slightly artificial settings – (i) adversarial user- i is a *strong* adversary if it may choose its own encoding map f_i in addition to the input vector \mathbf{x}_i , and (ii) an adversary is a *weak* adversary if it does not have access to its own random encoding map when choosing its input vector. In all cases, the adversary is unaware of the other users' encoding maps. We denote the corresponding randomized coding capacity region by $\mathcal{R}_{\text{random}}^{\text{strong}}$ and $\mathcal{R}_{\text{random}}^{\text{weak}}$ respectively. The three adversarial settings are depicted in Fig. 4. Clearly, $\mathcal{R}_{\text{random}}^{\text{strong}} \subseteq \mathcal{R}_{\text{random}} \subseteq \mathcal{R}_{\text{random}}^{\text{weak}}$.

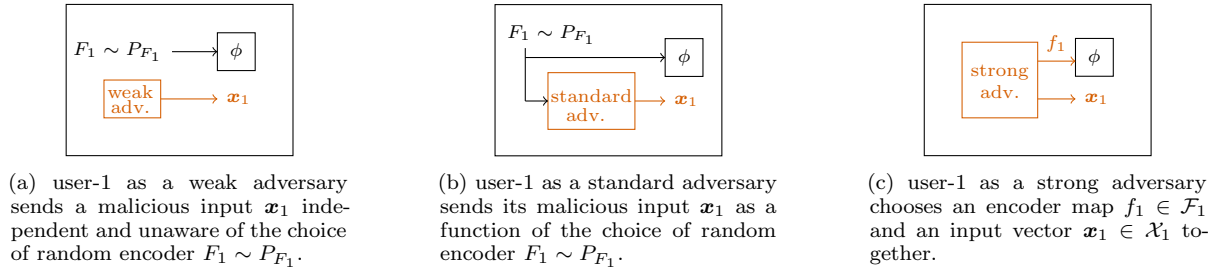

Figure 4: A figure depicting various adversary models for randomized coding when user-1 is malicious.

Analogous to the deterministic case, the average probability error P_e^{strong} under the strong adversary is defined (with an abuse of notation)⁸ as

$$P_e^{\text{strong}}(F_1, F_2, F_3, \phi) \stackrel{\text{def}}{=} \max\{P_{e,0}^{\text{rand}}, P_{e,1}^{\text{strong}}, P_{e,2}^{\text{strong}}, P_{e,3}^{\text{strong}}\},$$

where

$$P_{e,0}^{\text{rand}} \stackrel{\text{def}}{=} \frac{1}{N_1 N_2 N_3} \sum_{m_1, m_2, m_3} e_0^{\text{rand}}(m_1, m_2, m_3), \text{ where}$$

$$e_0^{\text{rand}}(m_1, m_2, m_3) = \mathbb{P}\left(\phi(Y^n, F_1, F_2, F_3) \neq (m_1, m_2, m_3) \mid \mathbf{X}_1 = F_1(m_1), \mathbf{X}_2 = F_2(m_2), \mathbf{X}_3 = F_3(m_3)\right).$$

⁸ P_e^{strong} depends on the distributions $P_{F_1}, P_{F_2}, P_{F_3}$ of the encoders, not on their realizations.

$P_{e,1}^{\text{strong}}$ is as below, $P_{e,2}^{\text{strong}}, P_{e,3}^{\text{strong}}$ are defined similarly.

$$P_{e,1}^{\text{strong}} \stackrel{\text{def}}{=} \max_{\mathbf{x}_1 \in \mathcal{X}^n, f_1 \in \mathcal{F}_1} \frac{1}{N_2 N_3} \sum_{m_2, m_3} e_{f_1}^{\text{strong}}(\mathbf{x}_1, m_2, m_3), \text{ where}$$

$$e_{f_1}^{\text{strong}}(\mathbf{x}_1, m_2, m_3) = \mathbb{P}\left(\left(\phi_2(\mathbf{Y}, f_1, F_2, F_3), \phi_3(\mathbf{Y}, f_1, F_2, F_3)\right) \neq (m_2, m_3) \middle| \mathbf{X}_1 = \mathbf{x}_1, \mathbf{X}_2 = F_2(m_2), \mathbf{X}_3 = F_3(m_3)\right).$$

We define achievable rate triples and capacity region for randomized codes in a similar manner as the deterministic case ⁹.

Definition 4 (Achievable rate triple and randomized coding capacity regions). We say a rate triple (R_1, R_2, R_3) is *achievable* against a strong adversary, if there is a sequence of $(\lfloor 2^{nR_1} \rfloor, \lfloor 2^{nR_2} \rfloor, \lfloor 2^{nR_3} \rfloor, n)$ codes $\{F_1^{(n)}, F_2^{(n)}, F_3^{(n)}, \phi^{(n)}\}_{n=1}^{\infty}$ such that $\lim_{n \rightarrow \infty} P_e^{\text{strong}}(F_1^{(n)}, F_2^{(n)}, F_3^{(n)}, \phi^{(n)}) \rightarrow 0$. The *strong randomized coding capacity region* $\mathcal{R}_{\text{random}}^{\text{strong}}$ is the closure of the set of all achievable rate triples.

Remark 1. The choice of a deterministic map as the decoder in Definition 3 is without loss of generality as a privately randomized decoder (independent of the randomness of the encoders) can be derandomized. This is because $P_e^{\text{strong}}(F_1, F_2, F_3, \phi)$ can be upper bounded by $P_{e,0}^{\text{rand}} + P_{e,1}^{\text{strong}} + P_{e,2}^{\text{strong}} + P_{e,3}^{\text{strong}}$. This upper bound can be written as an expectation over the randomness of the decoder. We may choose the deterministic decoder which maximizes this upper bound.

Probability of error and capacity region for randomized codes with a weak adversary are defined by replacing $P_{e,i}^{\text{strong}}$ with $P_{e,i}^{\text{weak}}, i = 1, 2, 3$ in the above definition, where

$$P_{e,1}^{\text{weak}} \stackrel{\text{def}}{=} \max_{\mathbf{x}_1 \in \mathcal{X}^n} \frac{1}{N_2 N_3} \sum_{m_2, m_3} e_1^{\text{weak}}(\mathbf{x}_1, m_2, m_3), \quad (4)$$

$$\text{where } e_1^{\text{weak}}(\mathbf{x}_1, m_2, m_3) = \mathbb{P}\left(\left(\phi_2(\mathbf{Y}, F_1, F_2, F_3), \phi_3(\mathbf{Y}, F_1, F_2, F_3)\right) \neq (m_2, m_3) \middle| \mathbf{X}_1 = \mathbf{x}_1, \mathbf{X}_2 = F_2(m_2), \mathbf{X}_3 = F_3(m_3)\right).$$

$P_{e,2}^{\text{weak}}$ and $P_{e,3}^{\text{weak}}$ are defined similarly.

For the standard adversary who has access to the random encoding map but is not allowed to choose it, the probability of error and the capacity region are defined in a similar fashion, by replacing $P_{e,i}^{\text{strong}}$ with $P_{e,i}^{\text{rand}}, i = 1, 2, 3$. We define $P_{e,1}^{\text{rand}}$ below. $P_{e,2}^{\text{rand}}$ and $P_{e,3}^{\text{rand}}$ are defined similarly.

$$P_{e,1}^{\text{rand}} \stackrel{\text{def}}{=} \max_{\mathbf{x}_1: \mathcal{F}_1 \rightarrow \mathcal{X}^n} \frac{1}{N_2 N_3} \sum_{m_2, m_3} e_1^{\text{rand}}(\mathbf{x}_1(\cdot), m_2, m_3), \text{ where}$$

$$e_1^{\text{rand}}(\mathbf{x}_1(\cdot), m_2, m_3) = \mathbb{P}\left(\left(\phi_2(\mathbf{Y}, F_1, F_2, F_3), \phi_3(\mathbf{Y}, F_1, F_2, F_3)\right) \neq (m_2, m_3) \middle| \mathbf{X}_1 = \mathbf{x}_1(F_1), \mathbf{X}_2 = F_2(m_2), \mathbf{X}_3 = F_3(m_3)\right).$$

The notation $\mathbf{x}_1(F_1)$ signifies that the adversary can choose the sequence \mathbf{x}_1 with the knowledge of the encoding map F_1 . The capacity region in this setting is denoted by $\mathcal{R}_{\text{random}}$. Restricting the attacks to deterministic attacks (i.e., deterministic maps $\mathbf{x}_1: \mathcal{F}_1 \rightarrow \mathcal{X}^n$) is without loss of generality along the lines of (2).

3.2 Main Results

3.2.1 Deterministic coding capacity region

We first present our results for deterministic codes. Analogous to the notion of symmetrizability [10, 22] in the AVC and AV-MAC literature, we give conditions under which at least one user cannot communicate with positive rate.

⁹Clearly, for randomized codes, the capacity region will remain unchanged for maximum and average probabilities of error criteria. Hence we only consider the average error criterion here.



Figure 5: We say $W_{Y|X_1X_2X_3}$ is $\mathcal{X}_2 \times \mathcal{X}_3$ -symmetrizable by \mathcal{X}_1 if, for each $(x_2, \tilde{x}_2, x_3, \tilde{x}_3)$, the conditional output distributions in the two cases above are the same. Thus, the receiver is unable to tell whether users 2 and 3 are sending (x_2, x_3) or $(\tilde{x}_2, \tilde{x}_3)$.



Figure 6: We say $W_{Y|X_1X_2X_3}$ is $\mathcal{X}_3|\mathcal{X}_2$ -symmetrizable by \mathcal{X}_1 if, for each (x_2, x_3, \tilde{x}_3) , the conditional output distributions in the two cases above are the same. The receiver is unable to tell whether user-3 is sending x_3 or \tilde{x}_3 .

3.2.1.1 Symmetrizability conditions

Definition 5. Let (i, j, k) be some permutation of $(1, 2, 3)$. We define three symmetrizability conditions for $W_{Y|X_1X_2X_3}$ (See Fig. 5-7).

1. We say that $W_{Y|X_1X_2X_3}$ is $\mathcal{X}_j \times \mathcal{X}_k$ -symmetrizable by \mathcal{X}_i if for some distribution $q(x_i|x_j, x_k)$

$$\begin{aligned}
& \sum_{x_i} q(x_i|\tilde{x}_j, \tilde{x}_k) W_{Y|X_iX_jX_k}(y|x_i, x_j, x_k) \\
&= \sum_{\tilde{x}_i} q(\tilde{x}_i|x_j, x_k) W_{Y|X_iX_jX_k}(y|\tilde{x}_i, \tilde{x}_j, \tilde{x}_k), \\
& \quad \forall x_j, \tilde{x}_j \in \mathcal{X}_j, x_k, \tilde{x}_k \in \mathcal{X}_k, y \in \mathcal{Y}.
\end{aligned} \tag{5}$$

2. We say that $W_{Y|X_1X_2X_3}$ is $\mathcal{X}_k|\mathcal{X}_j$ -symmetrizable by \mathcal{X}_i if for some distribution $q(x_i|x_k)$

$$\begin{aligned}
& \sum_{x_i} q(x_i|\tilde{x}_k) W_{Y|X_iX_jX_k}(y|x_i, x_j, x_k) \\
&= \sum_{\tilde{x}_i} q(\tilde{x}_i|x_k) W_{Y|X_iX_jX_k}(y|\tilde{x}_i, x_j, \tilde{x}_k), \\
& \quad \forall x_j \in \mathcal{X}_j, x_k, \tilde{x}_k \in \mathcal{X}_k, y \in \mathcal{Y}.
\end{aligned} \tag{6}$$

3. We say that $W_{Y|X_1X_2X_3}$ is \mathcal{X}_k -symmetrizable by $\mathcal{X}_i/\mathcal{X}_j$ if for some pair of distributions $q(x_i|\tilde{x}_i, \tilde{x}_k)$ and $q'(\tilde{x}_j|x_j, x_k)$

$$\begin{aligned}
& \sum_{x_i} q(x_i|\tilde{x}_i, \tilde{x}_k) W_{Y|X_iX_jX_k}(y|x_i, x_j, x_k) \\
&= \sum_{\tilde{x}_j} q'(\tilde{x}_j|x_j, x_k) W_{Y|X_iX_jX_k}(y|\tilde{x}_i, \tilde{x}_j, \tilde{x}_k), \\
& \quad \forall \tilde{x}_i \in \mathcal{X}_i, x_j \in \mathcal{X}_j, x_k, \tilde{x}_k \in \mathcal{X}_k, y \in \mathcal{Y}.
\end{aligned} \tag{7}$$



Figure 7: We say $W_{Y|X_1X_2X_3}$ is \mathcal{X}_3 -symmetrizable by $\mathcal{X}_1/\mathcal{X}_2$ if, for each $(\tilde{x}_1, x_2, x_3, \tilde{x}_3)$, the conditional output distributions in the two cases above are the same. The receiver is unable to tell whether user-3 is sending x_3 (and user-1 being malicious) or user-3 is sending \tilde{x}_3 (and user-2 being malicious).

We say that *user- k is symmetrizable* if any of the above three symmetrization conditions (5)-(7) holds for some distinct $i, j \in \{1, 2, 3\} \setminus \{k\}$. We say that the channel is *not symmetrizable* if user- k is not symmetrizable for every $k \in \{1, 2, 3\}$. Clearly, symmetrization conditions for the two-user AV-MAC with X_i as the state and X_j, X_k as the inputs are also symmetrization conditions for our problem. Thus, the first two conditions (5)-(6) (Figures 5 and 6) follow from Gubner [9]. The third condition (7) (Figure 7) is new (see Section 3.2.1.5) and arises from the byzantine nature of the users in this problem. We now argue that a symmetrizable user cannot communicate reliably using deterministic codes.

3.2.1.2 Symmetrization implies non-feasibility of communication. Suppose that (7) holds for $(i, j, k) = (1, 2, 3)$. Thus, user-3 is symmetrizable. In the following, we show that user-3 cannot communicate reliably at positive rates. For fixed vectors $(\tilde{x}_1, x_2, x_3, \tilde{x}_3)$, Eq. (7) with $(i, j, k) = (1, 2, 3)$ implies that the output is the same under the following two cases:

- (i) User 1 sends $\mathbf{X}_1 \sim q^n(\cdot | \tilde{x}_1, \tilde{x}_3)$, i.e., a vector distributed as the output of the memoryless channel q on input $(\tilde{x}_1, \tilde{x}_3)$ (see Figure 7 which depicts single use of the channel), user-2 and user-3 send x_2 and x_3 respectively, and
- (ii) User 2 sends $\mathbf{X}_2 \sim (q')^n(\cdot | x_2, x_3)$, and user-1 and user-3 send \tilde{x}_1 and \tilde{x}_3 respectively.

Hence, for a given $(\mathcal{M}_1, \mathcal{M}_2, \mathcal{M}_3, n)$ code (f_1, f_2, f_3, ϕ) and independent $\tilde{M}_1 \sim \text{Unif}(\mathcal{M}_1)$, $M_2 \sim \text{Unif}(\mathcal{M}_2)$, $M_3 \sim \text{Unif}(\mathcal{M}_3)$ and $\tilde{M}_3 \sim \text{Unif}(\mathcal{M}_3)$, the output distributions are identical in the following two cases:

- (i) User 1 sends $\mathbf{X}_1 \sim q^n(\cdot | f_1(\tilde{M}_1), f_3(\tilde{M}_3))$, user-2 and user-3 send $f_2(M_2)$ and $f_3(M_3)$ respectively, and
- (ii) User 2 sends $\mathbf{X}_2 \sim (q')^n(\cdot | f_2(M_2), f_3(M_3))$, and user-1 and user-3 send $f_1(\tilde{M}_1)$ and $f_3(\tilde{M}_3)$ respectively.

Thus, the receiver is unable to tell apart the two possibilities, i.e., whether user-1 is malicious with user-3 sending M_3 or user-2 is malicious with user-3 sending \tilde{M}_3 . We can argue along the similar lines to show that the symmetrized user(s) in (5) or (6) cannot communicate reliably. On the other hand, we can show that when no user is symmetrizable, we can work at positive rates. This brings us to our main result.

3.2.1.3 Deterministic capacity region. Let \mathcal{R} be the set of all rate triples (R_1, R_2, R_3) such that for some $p(u)p(x_1|u)p(x_2|u)p(x_3|u)$, the following conditions hold for all permutations (i, j, k) of $(1, 2, 3)$:

$$R_i \leq \min_{q(x_k|u)} I(X_i; Y | X_j, U), \quad \text{and} \quad (8)$$

$$R_i + R_j \leq \min_{q(x_k|u)} I(X_i, X_j; Y | U), \quad (9)$$

where the mutual information terms above are evaluated using the joint distribution $p(u)p(x_i|u)p(x_j|u)p(x_k|u)W_{Y|X_1X_2X_3}(y|x_1, x_2, x_3)$. Here $|\mathcal{U}| \leq 3$.

Theorem 1. $\mathcal{R}_{\text{deterministic}} = \mathcal{R}$ if $W_{Y|X_1X_2X_3}$ is not symmetrizable. Furthermore, $\text{int}(\mathcal{R}_{\text{deterministic}}) \neq \emptyset$ only if $W_{Y|X_1X_2X_3}$ is not symmetrizable.

Remark 2. As argued, we prove the converse part of Theorem 1 by showing that if user- k is symmetrizable, then any achievable rate triple (R_1, R_2, R_3) must be such that $R_k = 0$. Our capacity region characterization does not cover the case where some (but not all) users are symmetrizable. In this case, by Theorem 3 (which shows that $\mathcal{R}_{\text{random}} = \mathcal{R}$), \mathcal{R} restricted to rates of non-symmetrizable users is clearly an outer bound on $\mathcal{R}_{\text{deterministic}}$. It is tempting to conjecture that these regions are equal. A similar result for the two-user AV-MAC was recently proved by Pereg and Steinberg [11] for the case where the users can privately randomize.

3.2.1.4 Overview of the proof of Theorem 1. The detailed proof of Theorem 1 is given in Section 4.1. Here, we describe the main ideas behind the achievability. The codebooks used in the achievability are obtained by a random coding argument (see Lemma 4). We will briefly describe the decoder here and also point out its connection to the non-symmetrizability of the channel.



(a) $X'_2 X'_3 - X_1 - X_2 X_3 Y$ Markov chain holds approximately. (b) $X_2 X_3 - X'_1 - X'_2 X'_3 Y$ Markov chain holds approximately.

Figure 8: The subfigure (a) above describes the decoding condition 2a. The quantities in blue describe it operationally while the random variables describe the single-letter joint distribution. Non-symmetrizability implies that, for $(\mathbf{x}_1, \mathbf{x}'_1, f_2(m_2), f_2(m'_2), f_3(m_3), f_3(m'_3), \mathbf{y}) \in T^n_{X_1 X'_1 X_2 X'_2 X_3 X'_3 Y}$, both (a) and (b) cannot hold simultaneously (see Fig 5).



(a) $X'_3 - X_1 - X_2 X_3 Y$ Markov chain holds approximately. (b) $X_3 - X'_1 - X_2 X'_3 Y$ Markov chain holds approximately.

Figure 9: The subfigure (a) above describes the decoding condition 2b. The quantities in blue describe it operationally while the random variables describe the single-letter joint distribution. Non-symmetrizability implies that, for $(\mathbf{x}_1, \mathbf{x}'_1, f_2(m_2), f_3(m_3), f_3(m'_3), \mathbf{y}) \in T^n_{X_1 X'_1 X_2 X_3 X'_3 Y}$, both (a) and (b) cannot hold simultaneously (see Fig 6).



(a) $X'_1 X'_3 - X_1 - X_2 X_3 Y$ Markov chain holds approximately. (b) $X_2 X_3 - X'_2 - X'_1 X'_3 Y$ Markov chain holds approximately.

Figure 10: The subfigure (a) above describes the decoding condition 2c. The quantities in blue describe it operationally while the random variables describe the single-letter joint distribution. Non-symmetrizability implies that, for $(\mathbf{x}_1, f_1(m'_1), f_2(m_2), \mathbf{x}'_2, f_3(m_3), f_3(m'_3), \mathbf{y}) \in T^n_{X_1 X'_1 X_2 X'_2 X_3 X'_3 Y}$, both (a) and (b) cannot hold simultaneously (see Fig 7).

Upon receiving the channel output, the decoder works by separately collecting potential candidates for each user's input message and subjecting them to further checks. Finally, we will show that there will be at most one potential candidate for each user (see Lemma 2) which the decoder outputs. In the following, we describe these steps for decoding user-3's message. Similar procedures are also employed for user-1 and user-2's decoding.

Let \mathcal{C}_i , $i = 1, 2, 3$ denote the codebook of user- i . Given a received vector $\mathbf{y} \in \mathcal{Y}^n$, we say that the message $m_3 \in \mathcal{M}_3$ of user-3 is a ‘‘candidate’’ with an ‘‘explanation’’ $(\mathbf{x}_1, \mathbf{x}_2) \in (\mathcal{X}_1^n \times \mathcal{C}_2) \cup (\mathcal{C}_1 \times \mathcal{X}_2^n)$ if the tuple $(\mathbf{x}_1, \mathbf{x}_2, f_3(m_3), \mathbf{y})$ is jointly typical with respect to a joint distribution that corresponds to independent channel inputs and the channel output following the channel conditional distribution given the inputs. The choice of the set of explanations is motivated by the fact that at most one user can be malicious. Note that, in general, a candidate message may have multiple explanations.

1. The decoder first forms a list of all candidate messages of user-3 along with their explanations.
2. The list of such candidate messages is then pruned by only keeping those messages that ‘‘account’’ for every other candidate message in the sense described below. Suppose that the candidate message m_3 has an explanation of the form $(\mathbf{x}_1, f_2(m_2))$ for some $\mathbf{x}_1 \in \mathcal{X}_1^n$ and $m_2 \in \mathcal{M}_2$. Similar procedures are followed if the explanation for m_3 is of the form $(f_1(m_1), \mathbf{x}_2)$ by interchanging the roles of user-1 and user-2 below. Let m'_3 be another candidate message. We say that m_3 accounts for m'_3 if one of the following three conditions is satisfied.
 - (a) m'_3 has an explanation $(\mathbf{x}'_1, f_2(m'_2))$ for some $m'_2 \neq m_2$, such that the collection $(\mathbf{x}_1, f_2(m_2), f_2(m'_2), f_3(m_3), f_3(m'_3), \mathbf{y})$ may be interpreted as typical instances drawn from a distribution $P_{X_1 X_2 X'_2 X_3 X'_3 Y}$ that specifies that $X'_2 X'_3$ and $X_2 X_3 Y$ are (roughly) conditionally independent given X_1 . The condition 2a may be interpreted as follows: \mathbf{x}_1 , $f_2(m_2)$, and $f_3(m_3)$ as inputs to the channel are a more plausible explanation of the channel output than the alternative input $(f_2(m'_2), f_3(m'_3))$, which is part of (adversarial) user-1’s attack strategy (see Fig 5a and Fig. 8a). It can be shown that for a non-symmetrizable channel, an analogue of Fig. 5b (see Fig. 8b), which (roughly) corresponds to the Markov chain $X_2 X_3 - X_1 - X'_2 X'_3 Y$, cannot simultaneously hold (also see proof of Lemma 2).
 - (b) m'_3 has an explanation $(\mathbf{x}'_1, f_2(m_2))$ such that the collection $(\mathbf{x}_1, f_2(m_2), f_3(m_3), f_3(m'_3), \mathbf{y})$ may be interpreted as typical instances drawn from a distribution $P_{X_1 X_2 X_3 X'_3 Y}$ that specifies that X'_3 and $X_2 X_3 Y$ are (roughly) conditionally independent given X_1 (see Fig. 9).
 - (c) m'_3 has an explanation $(f_1(m'_1), \mathbf{x}'_2)$ such that the collection $(\mathbf{x}_1, f_1(m'_1), f_2(m_2), f_3(m_3), f_3(m'_3), \mathbf{y})$ may be interpreted as typical instances drawn from a distribution $P_{X_1 X'_1 X_2 X_3 X'_3 Y}$ that specifies that $X'_1 X'_3$ and $X_2 X_3 Y$ are (roughly) conditionally independent given X_1 (see Fig. 10).

See the decoder definition below for a complete description, which accounts for all candidates. Items (a) and (b) in the decoder definition are similar to the decoding conditions in [10] where user- i is the adversary and \mathbf{x}_i is the state. Item (c) is associated with our new non-symmetrizability criterion (see Fig. 7) and handles the situation in which an adversarial user tries to make another user appear adversarial while pretending to act honestly.

Decoder: Let $\eta > 0$. For a received vector $\mathbf{y} \in \mathcal{Y}^n$, the decoder outputs $\phi(\mathbf{y}) = (m_1, m_2, m_3) \in \mathcal{M}_1 \times \mathcal{M}_2 \times \mathcal{M}_3$ if $\mathbf{y} \in \mathcal{D}_{m_1}^{(1)} \cap \mathcal{D}_{m_2}^{(2)} \cap \mathcal{D}_{m_3}^{(3)}$ where $\mathcal{D}_{m_i}^{(i)}$, $i = 1, 2, 3$ is defined as below.

$\mathbf{y} \in \mathcal{D}_{m_3}^{(3)}$ if there exists some permutation (i, j) of $(1, 2)$, $m_j \in \mathcal{M}_j$, $\mathbf{x}_i \in \mathcal{X}_i^n$, and random variables X_i, X_j, X_3 with $(\mathbf{x}_i, f_j(m_j), f_3(m_3), \mathbf{y}) \in T_{X_i X_j X_3 Y}^n$ and $D(P_{X_i X_j X_3 Y} \| P_{X_i} \times P_{X_j} \times P_{X_3} \times W) < \eta$ such that the following hold:

- (a) Disambiguating (m_j, m_3) from (m'_j, m'_3) : For every $(m'_j, m'_3) \in \mathcal{M}_j \times \mathcal{M}_3$, $m'_j \neq m_j$, $m'_3 \neq m_3$, $\mathbf{x}'_i \in \mathcal{X}_i^n$, and random variables X'_i, X'_j, X'_3 such that $(\mathbf{x}_i, \mathbf{x}'_i, f_j(m_j), f_j(m'_j), f_3(m_3), f_3(m'_3), \mathbf{y}) \in T_{X_i X'_i X_j X'_j X_3 X'_3 Y}^n$ and $D(P_{X'_i X'_j X'_3 Y} \| P_{X'_i} \times P_{X'_j} \times P_{X'_3} \times W) < \eta$, we require that $I(X_j X_3 Y; X'_j X'_3 | X_i) < \eta$.
- (b) Disambiguating m_3 from m'_3 : For every $m'_3 \in \mathcal{M}_3$, $m'_3 \neq m_3$, $\mathbf{x}'_i \in \mathcal{X}_i^n$, and random variables X'_i, X'_3 such that $(\mathbf{x}_i, \mathbf{x}'_i, f_j(m_j), f_3(m_3), f_3(m'_3), \mathbf{y}) \in T_{X_i X'_i X_j X_3 X'_3 Y}^n$ and $D(P_{X'_i X_j X'_3 Y} \| P_{X'_i} \times P_{X_j} \times P_{X'_3} \times W) < \eta$, we require that $I(X_j X_3 Y; X'_3 | X_i) < \eta$.
- (c) Disambiguating (m_j, m_3) from (m_i, m'_3) : If there exist $(m_i, m'_3) \in \mathcal{M}_i \times \mathcal{M}_3$, $m'_3 \neq m_3$, $\mathbf{x}_j \in \mathcal{X}_j^n$, and random variables X'_i, X'_j, X'_3 such that $(\mathbf{x}_i, f_i(m_i), f_j(m_j), \mathbf{x}_j, f_3(m_3), f_3(m'_3), \mathbf{y}) \in T_{X_i X'_i X_j X'_j X_3 X'_3 Y}^n$ and $D(P_{X'_i X'_j X'_3 Y} \| P_{X'_i} \times P_{X_j} \times P_{X'_3} \times W) < \eta$, we require that $I(X_j X_3 Y; X'_i X'_3 | X_i) < \eta$.

The decoding sets $\mathcal{D}_{m_1}^{(1)}$ and $\mathcal{D}_{m_2}^{(2)}$ are defined similarly. If $\mathbf{y} \notin \mathcal{D}_{m_1}^{(1)} \cap \mathcal{D}_{m_2}^{(2)} \cap \mathcal{D}_{m_3}^{(3)}$ for all $(m_1, m_2, m_3) \in \mathcal{M}_1 \times \mathcal{M}_2 \times \mathcal{M}_3$, the decoder outputs $(1, 1, 1)$.

Note that the decoder is not well defined if $\mathbf{y} \in \mathcal{D}_{m_1}^{(1)} \cap \mathcal{D}_{m_2}^{(2)} \cap \mathcal{D}_{m_3}^{(3)}$ and $\mathbf{y} \in \mathcal{D}_{m'_1}^{(1)} \cap \mathcal{D}_{m'_2}^{(2)} \cap \mathcal{D}_{m'_3}^{(3)}$ for $(m_1, m_2, m_3) \neq (m'_1, m'_2, m'_3)$. This is ruled out by the following lemma (proved in Appendix A) which guarantees that, for sufficiently small $\eta > 0$, there is at most one triple (m_1, m_2, m_3) such that $\mathbf{y} \in \mathcal{D}_{m_1}^{(1)} \cap \mathcal{D}_{m_2}^{(2)} \cap \mathcal{D}_{m_3}^{(3)}$. This is analogous to [22, Lemma 4].

Lemma 2 (Disambiguity of decoding). Suppose the channel $W_{Y|X_1 X_2 X_3}$ is not symmetrizable. Let $P_{X_1} \in \mathcal{P}_{\mathcal{X}_1}^n$, $P_{X_2} \in \mathcal{P}_{\mathcal{X}_2}^n$ and $P_{X_3} \in \mathcal{P}_{\mathcal{X}_3}^n$ be distributions such that for some $\alpha > 0$, $\min_{x_1} P_{X_1}(x_1), \min_{x_2} P_{X_2}(x_2), \min_{x_3} P_{X_3}(x_3) \geq \alpha$. Let $f_1 : \mathcal{M}_1 \rightarrow T_{X_1}^n$, $f_2 : \mathcal{M}_2 \rightarrow T_{X_2}^n$ and $f_3 : \mathcal{M}_3 \rightarrow T_{X_3}^n$ be any encoding maps. There exists a choice of $\eta > 0$ such that if $(\tilde{m}_1, \tilde{m}_2, \tilde{m}_3) \neq (m_1, m_2, m_3)$, then $(\mathcal{D}_{\tilde{m}_1}^{(1)} \cap \mathcal{D}_{\tilde{m}_2}^{(2)} \cap \mathcal{D}_{\tilde{m}_3}^{(3)}) \cap (\mathcal{D}_{m_1}^{(1)} \cap \mathcal{D}_{m_2}^{(2)} \cap \mathcal{D}_{m_3}^{(3)}) = \emptyset$.

Notice that the decoder definition does not require consistency of the input message for the same user. For example, when $\mathbf{y} \in \mathcal{D}_{m_1}^{(1)} \cap \mathcal{D}_{m_2}^{(2)} \cap \mathcal{D}_{m_3}^{(3)}$, in which case the decoder outputs (m_1, m_2, m_3) , the message m_2 plays no special role in $\mathcal{D}_{m_1}^{(1)}$ or $\mathcal{D}_{m_3}^{(3)}$. That is, an ‘‘explanation’’ for the candidate m_1 may be $(f_2(\tilde{m}_2), \mathbf{x}_3) \in \mathcal{X}_2^n \times \mathcal{X}_3^n$ which passes checks (a), (b) and (c) in the definition of $\mathcal{D}_{m_1}^{(1)}$ where \tilde{m}_2 need not be same as m_2 or even be unique (for instance, there might be another simultaneous ‘‘explanation’’ $(f_2(m'_2), \mathbf{x}'_3)$). At the same time, an ‘‘explanation’’ for the candidate m_3 which passes checks (a), (b) and (c) of $\mathcal{D}_{m_3}^{(3)}$ may be $(\mathbf{x}_1, f_2(\hat{m}_2)) \in \mathcal{X}_1^n \times \mathcal{X}_2^n$ where \hat{m}_2 need not be same as \hat{m}_2 or m_2 .

3.2.1.5 ‘‘ \mathcal{X}_k -symmetrizable by $\mathcal{X}_i/\mathcal{X}_j$ ’’ is new. The following example shows that the third symmetrizability condition (7) does not imply the others. The channel below is neither $\mathcal{X}_j \times \mathcal{X}_k$ -symmetrizable by \mathcal{X}_i nor $\mathcal{X}_k|\mathcal{X}_j$ -symmetrizable by \mathcal{X}_i for any permutation (i, j, k) of $(1, 2, 3)$. However, it is \mathcal{X}_3 -symmetrizable by $\mathcal{X}_1/\mathcal{X}_2$.

Example 1. Let $\mathcal{X}_1 = \mathcal{X}_2 = \mathcal{Y} = \{0, 1\}^3$ and $\mathcal{X}_3 = \{0, 1\}$. Consider the channel $W_{Y|X_1 X_2 X_3}$ (where the output is $Y = (Y_1, Y_2, Y_3)$) defined by

$$(Y_1, Y_2) = (C_1, C_2),$$

$$Y_3 = \begin{cases} B_1 \oplus (A_1 \odot X_3) & \text{w.p. } 1/2 \\ B_2 \oplus (A_2 \odot X_3) & \text{w.p. } 1/2 \end{cases}$$

where \odot denotes multiplication and \oplus denotes addition modulo 2.

To see that this channel is \mathcal{X}_3 -symmetrizable by $\mathcal{X}_1/\mathcal{X}_2$, consider the ‘‘deterministic’’ $q((a_1, b_1, c_1)|(\tilde{a}_1, \tilde{b}_1, \tilde{c}_1), \tilde{x}_3)$ and $q'((\tilde{a}_2, \tilde{b}_2, \tilde{c}_2)|(a_2, b_2, c_2), x_3)$, for $(a_1, b_1, c_1), (\tilde{a}_1, \tilde{b}_1, \tilde{c}_1) \in \mathcal{X}_1, (\tilde{a}_2, \tilde{b}_2, \tilde{c}_2), (a_2, b_2, c_2) \in \mathcal{X}_2$ and $\tilde{x}_3, x_3 \in \mathcal{X}_3$, defined as follows: let $g, g' : \{0, 1\}^4 \rightarrow \{0, 1\}^2$ be defined as

$$g((\tilde{a}_1, \tilde{b}_1, \tilde{c}_1), \tilde{x}_3) = (0, \tilde{b}_1 \oplus (\tilde{a}_1 \odot \tilde{x}_3), \tilde{c}_1),$$

$$g'((a_2, b_2, c_2), x_3) = (0, b_2 \oplus (a_2 \odot x_3), c_2).$$

Then

$$q((a_1, b_1, c_1)|(\tilde{a}_1, \tilde{b}_1, \tilde{c}_1), \tilde{x}_3) = 1_{\{(a_1, b_1, c_1)=g((\tilde{a}_1, \tilde{b}_1, \tilde{c}_1), \tilde{x}_3)\}},$$

$$q'((\tilde{a}_2, \tilde{b}_2, \tilde{c}_2)|(a_2, b_2, c_2), x_3) = 1_{\{(\tilde{a}_2, \tilde{b}_2, \tilde{c}_2)=g'((a_2, b_2, c_2), x_3)\}}.$$

Consider the two cases shown in Figure 7 with $\tilde{x}_1 = (\tilde{a}_1, \tilde{b}_1, \tilde{c}_1)$, $x_2 = (a_2, b_2, c_2)$, and q and q' defined as above. It follows that, in both the cases, the channel output Y has the same conditional distribution given each input. In particular,

$$(Y_1, Y_2) = (c_1, c_2),$$

$$Y_3 = \begin{cases} \tilde{b}_1 \oplus (\tilde{a}_1 \odot \tilde{x}_3) & \text{w.p. } 1/2 \\ b_2 \oplus (a_2 \odot x_3) & \text{w.p. } 1/2. \end{cases}$$

This shows that the symmetrizability condition (7) holds for $(i, j, k) = (1, 2, 3)$.

Since $(Y_1, Y_2) = (C_1, C_2)$, it is clear that neither user-1 nor user-2 is symmetrizable. It only remains to be shown that the channel is neither $\mathcal{X}_3|\mathcal{X}_2$ -symmetrizable by \mathcal{X}_1 nor $\mathcal{X}_3|\mathcal{X}_1$ -symmetrizable by \mathcal{X}_2 . Suppose the channel is $\mathcal{X}_3|\mathcal{X}_2$ -symmetrizable by \mathcal{X}_1 . Then, to satisfy (6) for $x_2 = (0, 0, c_2)$ and $(x_3, \tilde{x}_3) = (0, 1)$, it must hold that

$$\begin{aligned} & q(0, 0, 0|1) + q(0, 0, 1|1) + q(1, 0, 0|1) + q(1, 0, 1|1) \\ &= q(1, 1, 0|0) + q(1, 1, 1|0) + q(0, 0, 0|0) + q(0, 0, 1|0). \end{aligned}$$

However, to satisfy (6) for $x_2 = (1, 0, c_2)$ and $(x_3, \tilde{x}_3) = (0, 1)$, we must also satisfy

$$\begin{aligned} & 1 + q(0, 0, 0|1) + q(0, 0, 1|1) + q(1, 0, 0|1) + q(1, 0, 1|1) \\ &= q(1, 1, 0|0) + q(1, 1, 1|0) + q(0, 0, 0|0) + q(0, 0, 1|0), \end{aligned}$$

which is a contradiction. Hence, the channel is not $\mathcal{X}_3|\mathcal{X}_2$ -symmetrizable by \mathcal{X}_1 . By symmetry, it is also not $\mathcal{X}_3|\mathcal{X}_1$ -symmetrizable by \mathcal{X}_2 .

3.2.2 Randomized coding capacity region

Theorem 3.

$$\mathcal{R}_{\text{random}}^{\text{strong}} = \mathcal{R}_{\text{random}} = \mathcal{R}_{\text{random}}^{\text{weak}} = \mathcal{R}.$$

We prove this by showing an achievability for the strong adversary and a converse for the weak adversary.

Remark 3. The statement $\mathcal{R}_{\text{deterministic}} = \mathcal{R}$, if $\text{int}(\mathcal{R}_{\text{deterministic}}) \neq \emptyset$ can also be shown directly using the extension, provided in [8], of the elimination technique [13] to first show that n^2 -valued randomness at each encoder is sufficient to achieve any rate-triple in $\mathcal{R}_{\text{random}}^{\text{weak}}$ (see Lemma 16). A deterministic code of small rate can be used to send $2 \log_2 n$ bits out of each message. These message bits are then used as the encoder randomness in the next phase to communicate the rest of the message bits using a randomized code.

Below, we sketch the proof of achievability for the strong adversary setting. A detailed achievability proof for the strong adversary and a converse proof for the weak adversary case are available in Section 4.2.

Proof sketch (achievability of Theorem 3). The scheme is depicted in Figure 11. The achievability uses the two-user AV-MAC randomized code used in the proof of [8, Theorem 1]. Let (R_1, R_2, R_3) be a rate triple such that, for some $p_1(x_1)p_2(x_2)p_3(x_3)$, the following conditions hold for all permutations (i, j, k) of $(1, 2, 3)$:

$$\begin{aligned} R_i &< \min_{q(x_k)} I(X_i; Y|X_j), \quad \text{and} \\ R_i + R_j &< \min_{q(x_k)} I(X_i, X_j; Y), \end{aligned}$$

with the mutual information terms evaluated using the joint distribution $p_i(x_i)p_j(x_j)q(x_k)W_{Y|X_1X_2X_3}(y|x_1, x_2, x_3)$. Note that, by the first part of the direct result of [8, Theorem 1] (see [8, Section III-C]), the rate pair (R_i, R_j) is an achievable rate pair for the AV-MAC $W^{(k)}$. Here, $W^{(k)}$ is the two-user AV-MAC formed by the channel inputs from user- k as the state and the remaining channel inputs as the inputs of the legitimate users of the AV-MAC.

In order to design a code for the byzantine-MAC, for each user- $i \in \{1, 2, 3\}$, we consider the randomized encoder F_i which maps each message independently to a codeword generated i.i.d. according to p_i . The realization of each user's codebook is shared with the decoder as independent shared randomness, i.e., F_1, F_2 and F_3 are independent. We note that the encoders F_i and F_j are identical to the ones in the proof of [8, Theorem 1, Section III-C] for the two user AV-MAC $W^{(k)}$. The decoder for the byzantine-MAC will be implemented using the decoders $\phi^{(1)}(F_2, F_3)$,

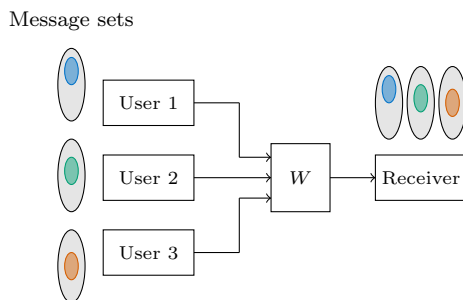

(a) The figure shows the message sets for each user. For each message set, a subset (shown in color) is picked randomly using the independent randomness shared with the decoder. Only the messages in the colored subset are valid messages and used for communication in the byzantine-MAC.

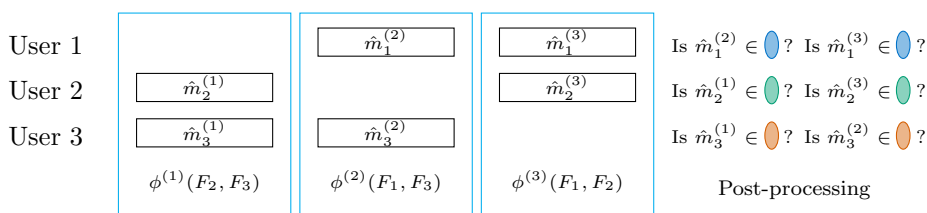

(b) The decoder works in two steps. Suppose the encoders are F_1 , F_2 and F_3 . To decode user-1's message, the decoder uses the decoder $\phi^{(2)}(F_1, F_3)$ of AV-MAC $W^{(2)}$ and $\phi^{(3)}(F_1, F_2)$ of AV-MAC $W^{(3)}$, to get candidates $\hat{m}_1^{(2)}$ and $\hat{m}_1^{(3)}$ respectively. These candidates pass through a further post-processing step where a candidate which does not belong to the set of valid messages is rejected. If user-1 is honest, at least one of the the decoders among $\phi^{(2)}(F_1, F_3)$ and $\phi^{(3)}(F_1, F_2)$ will output correctly with high probability. Since, a small set of valid messages was chosen using independent shared randomness, a malicious user cannot correlate their attack with messages of honest user(s) with high probability. This ensures that erroneous messages are rejected in the post-processing step. The decoder for other users proceeds similarly.

Figure 11: A figure depicting the decoder for the randomized code of a 3-user byzantine-MAC

$\phi^{(2)}(F_1, F_3)$ and $\phi^{(3)}(F_1, F_2)$ (from the proof of [8, Theorem 1, Section III-C]) of AV-MACs $W^{(1)}$, $W^{(2)}$ and $W^{(3)}$ corresponding to the encoder pairs (F_2, F_3) , (F_1, F_3) and (F_1, F_2) respectively. It is clear that if, say, user-3 is malicious, and honest users-1 and 2 send m_1 and m_2 respectively, then the output $(\hat{m}_1^{(3)}, \hat{m}_2^{(3)})$ of the decoder $\phi^{(3)}(F_1, F_2)$ will match (m_1, m_2) with high probability. However, since the decoder does not know the identity of the malicious user, there is an additional decoded message $\hat{m}_1^{(2)}$ from decoder $\phi^{(2)}(F_1, F_3)$ for user-1 (and similarly there is an additional decoded message for user-2 from $\phi^{(1)}(F_2, F_3)$). The message $\hat{m}_1^{(2)}$ can potentially be different from $\hat{m}_1^{(3)}$. This is because the decoder $\phi^{(2)}(F_1, F_3)$ assumes that user-3 is honest and no decoding guarantees are available for its output when user-3 is in fact malicious. When $\hat{m}_1^{(3)} \neq \hat{m}_1^{(2)}$, it is not clear what the receiver should output as the decoded message for user-1. This is where we can leverage the independent shared randomness shared by each user with the receiver.

We use a form of random hashing in order to add a further post-processing step which filters the outputs of the decoders of the AV-MACs as follows. Using the randomness they share with the receiver, each user randomly selects a subset of the original message set which is of nearly the same rate but is only a small fraction of original message set in size. These randomly selected subsets will be the valid message sets for communication in the byzantine-MAC. If the decoders of AV-MACs decode to messages which are not in these randomly selected subsets, they will be rejected in the post-processing step. Since these subsets are chosen using the independent shared randomness between each user and the receiver, their identity is hidden from the malicious user. For a malicious user-3, the output of $\phi^{(3)}(F_1, F_2)$ will be correct with high probability and will be accepted in the post-processing step as honest users-1 and 2 will only send valid messages. On the other hand, the outputs of $\phi^{(1)}(F_2, F_3)$ and $\phi^{(2)}(F_1, F_3)$ will be rejected with high probability if they are different from the output of $\phi^{(3)}(F_1, F_2)$. This is because the size of valid message set is only a very small fraction of the original message set, so an arbitrary decoded message will fall outside the set of valid messages with high probability. This crucially uses the fact that these sets are constructed using independent shared randomness which protects the identity of the set of valid messages (and thus the set of valid codewords) and prevents the malicious user from correlating the attack with those messages. These ideas are formalized in Section 4.2. \square

4 Proofs

4.1 Deterministic coding capacity region (Theorem 1)

Proof (Converse of Theorem 1). The outer bound on the rate region, when non-empty, follows from Theorem 3. Below, we show that a symmetrizable user cannot communicate.

Clearly, symmetrizability conditions for the two-user AV-MAC with \mathcal{X}_i as the state alphabet and $\mathcal{X}_j, \mathcal{X}_k$ as the input alphabets are also symmetrizability conditions for our problem. Conditions 1 and 2 follow from Gubner [9].

To analyze the rate region when condition 3 holds, consider $(i, j, k) = (1, 2, 3)$, the other cases follow similarly. Suppose $q(\tilde{x}_1|x_1, x_3)$ and $q'(\tilde{x}_j|x_j, x_k)$ satisfy (7), i.e.,

$$\begin{aligned} & \sum_{\tilde{x}_1} q(\tilde{x}_1|x_1, \tilde{x}_3) W_{Y|X_1 X_2 X_3}(y|\tilde{x}_1, x_2, x_3) \\ &= \sum_{\tilde{x}_2} q'(\tilde{x}_2|x_2, x_3) W_{Y|X_1 X_2 X_3}(y|x_1, \tilde{x}_2, \tilde{x}_3), \\ & \forall x_1 \in \mathcal{X}_1, x_2 \in \mathcal{X}_2, x_3, \tilde{x}_3 \in \mathcal{X}_3, y \in \mathcal{Y}. \end{aligned} \tag{10}$$

Let $m_3, \tilde{m}_3 \in \mathcal{M}_3$ be distinct, and let $\mathbf{x}_3 = f_3(m_3)$ and $\tilde{\mathbf{x}}_3 = f_3(\tilde{m}_3)$. We consider two different settings in which user-3 sends \mathbf{x}_3 and $\tilde{\mathbf{x}}_3$ respectively:

- (i) In the first setting, user-1 is adversarial. It chooses an $M_1 \sim \text{Unif}(\mathcal{M}_1)$. Let $\mathbf{X}_1 = f_1(M_1)$. To produce its input $\tilde{\mathbf{X}}_{1, \tilde{m}_3}$ to the channel, it passes $(\mathbf{X}_1, \tilde{\mathbf{x}}_3)$ through q^n , the n -fold product of the channel $q(\tilde{x}_1|x_1, x_3)$. user-2, being non-adversarial, sends as its input to the channel $\mathbf{X}_2 = f_2(M_2)$, where $M_2 \sim \text{Unif}(\mathcal{M}_2)$. user-3

sends \mathbf{x}_3 corresponding to message m_3 . The distribution of the received vector in this case is

$$\frac{1}{N_1 N_2} \sum_{m_1, m_2} \prod_{t=1}^n \sum_{\tilde{x}_{1, \tilde{m}_3, t}} q(\tilde{x}_{1, \tilde{m}_3, t} | f_{1,t}(m_1), \tilde{x}_{3,t}) W_{Y|X_1 X_2 X_3}(y_t | \tilde{x}_{1, \tilde{m}_3, t}, f_{2,t}(m_2), x_{3,t}).$$

(ii) In the second setting, user-2 is adversarial. It chooses an $M_2 \sim \text{Unif}(\mathcal{M}_2)$. Let $\mathbf{X}_2 = f_2(M_2)$. To produce its input $\tilde{\mathbf{X}}_{2, m_3}$ to the channel, it passes $(\mathbf{X}_2, \mathbf{x}_3)$ through q'^n , the n -fold product of the channel $q'(\tilde{x}_2 | x_2, x_3)$. user-1, being non-adversarial now, sends as its input to the channel $\mathbf{X}_1 = f_1(M_1)$, where $M_1 \sim \text{Unif}(\mathcal{M}_1)$. user-3 here sends $\tilde{\mathbf{x}}_3$ corresponding to message \tilde{m}_3 . Here, the distribution of the received vector is

$$\frac{1}{N_1 N_2} \sum_{m_1, m_2} \prod_{t=1}^n \sum_{\tilde{x}_{2, m_3, t}} q'(\tilde{x}_{2, m_3, t} | f_{2,t}(m_2), x_{3,t}) W_{Y|X_1 X_2 X_3}(y_t | f_{1,t}(m_1), \tilde{x}_{2, m_3, t}, \tilde{x}_{3,t}).$$

By (10), the above two distributions are identical. Hence, for any decoder, the sum of probabilities of decoding error for messages m_3 and \tilde{m}_3 must be at least 1, i.e., if we define $e_1^3(m_3, \tilde{\mathbf{x}}_1) \stackrel{\text{def}}{=} \frac{1}{N_2} \sum_{m'_2} e_1(\tilde{\mathbf{x}}_1, m'_2, m_3)$ and similarly $e_2^3(\tilde{m}_3, \tilde{\mathbf{x}}_2) \stackrel{\text{def}}{=} \frac{1}{N_1} \sum_{m'_1} e_2(m'_1, \tilde{\mathbf{x}}_2, \tilde{m}_3)$, then

$$\begin{aligned} E_{\tilde{\mathbf{X}}_{1, \tilde{m}_3}} [e_1^3(m_3, \tilde{\mathbf{X}}_{1, \tilde{m}_3})] + E_{\tilde{\mathbf{X}}_{2, m_3}} [e_2^3(\tilde{m}_3, \tilde{\mathbf{X}}_{2, m_3})] &= \\ & \sum_{\mathbf{y}: \phi(\mathbf{y}) \neq m_3} \left(\frac{1}{N_1 N_2} \sum_{m_1, m_2} \prod_{t=1}^n \sum_{\tilde{x}_{1,t}} q(\tilde{x}_{1,t} | f_{1,t}(m_1), \tilde{x}_{3,t}) W_{Y|X_1 X_2 X_3}(y_t | \tilde{x}_{1,t}, f_{2,t}(m_2), x_{3,t}) \right) \\ & + \sum_{\mathbf{y}: \phi(\mathbf{y}) \neq \tilde{m}_3} \left(\frac{1}{N_1 N_2} \sum_{m_1, m_2} \prod_{t=1}^n \sum_{\tilde{x}_{2,t}} q'(\tilde{x}_{2,t} | f_{2,t}(m_2), x_{3,t}) W_{Y|X_1 X_2 X_3}(y_t | f_{1,t}(m_1), \tilde{x}_{2,t}, \tilde{x}_{3,t}) \right) \\ & \stackrel{\text{(a)}}{\geq} 1, \end{aligned}$$

where (a) follows from (10).

Note that the distribution of $\tilde{\mathbf{X}}_1$ (resp. $\tilde{\mathbf{X}}_2$) does not depend on m_3 (resp. \tilde{m}_3). Arguing along the lines of [22, (3.29) in page 187],

$$\begin{aligned} 2P_e(f_1, f_2, f_3, \phi) &\geq P_{e,1} + P_{e,2} \\ &\geq \frac{1}{N_3} \sum_{m_3} E_{\tilde{\mathbf{X}}_1} [e_1^3(m_3, \tilde{\mathbf{X}}_1)] + \frac{1}{N_3} \sum_{m_3} E_{\mathbf{X}_2} [e_1^3(m_3, \mathbf{X}_2)] \end{aligned}$$

for any attack vectors $\tilde{\mathbf{X}}_1$ and $\tilde{\mathbf{X}}_2$. In particular, for the attack vectors $\frac{1}{N_3} \sum_{\tilde{m}_3} \tilde{\mathbf{X}}_{1, \tilde{m}_3}$ and $\frac{1}{N_3} \sum_{m_3} \tilde{\mathbf{X}}_{2, m_3}$,

$$2P_e(f_1, f_2, f_3, \phi) \geq \frac{1}{N_3^2} \sum_{\tilde{m}_3} \sum_{m_3} \left(E_{\tilde{\mathbf{X}}_{1, \tilde{m}_3}} [e_1^3(m_3, \tilde{\mathbf{X}}_{1, \tilde{m}_3})] + E_{\tilde{\mathbf{X}}_{2, m_3}} [e_2^3(\tilde{m}_3, \tilde{\mathbf{X}}_{2, m_3})] \right).$$

For $m_3 \neq \tilde{m}_3$, the term in brackets on the right is upper bounded by 1, otherwise it is upper bounded by zero. Thus,

$$\begin{aligned} P_e(f_1, f_2, f_3, \phi) &\geq \frac{N_3(N_3 - 1)/2}{2N_3^2} \\ &\geq \frac{1}{8}. \end{aligned}$$

□

Next, we turn to achievability of Theorem 1. It uses [23, Theorem 2.1] which provides a concentration result for dependent random variables. We use it to obtain the codebook given below.

Lemma 4. For any $\epsilon > 0$, $n \geq n_0(\epsilon)$, $N_1, N_2, N_3 \geq \exp(n\epsilon)$ and types $P_1 \in \mathcal{P}_{\mathcal{X}_1}^n$, $P_2 \in \mathcal{P}_{\mathcal{X}_2}^n$, $P_3 \in \mathcal{P}_{\mathcal{X}_3}^n$, there exists codebooks $\{\mathbf{x}_{11}, \dots, \mathbf{x}_{1N_1} \in \mathcal{X}_1^n\}$, $\{\mathbf{x}_{21}, \dots, \mathbf{x}_{2N_2} \in \mathcal{X}_2^n\}$, $\{\mathbf{x}_{31}, \dots, \mathbf{x}_{3N_3} \in \mathcal{X}_3^n\}$ whose codewords are of type P_1, P_2, P_3 respectively such that for every permutation (i, j, k) of $(1, 2, 3)$; for every $(\mathbf{x}_i, \mathbf{x}_j, \mathbf{x}_k) \in \mathcal{X}_i^n \times \mathcal{X}_j^n \times \mathcal{X}_k^n$; for every joint type $P_{X_i X'_i X_j X'_j X_k X'_k} \in \mathcal{P}_{\mathcal{X}_i \times \mathcal{X}_i \times \mathcal{X}_j \times \mathcal{X}_j \times \mathcal{X}_k \times \mathcal{X}_k}^n$; and for $R_i \stackrel{\text{def}}{=} (1/n) \log_2 N_i$, $R_j \stackrel{\text{def}}{=} (1/n) \log_2 N_j$, and $R_k \stackrel{\text{def}}{=} (1/n) \log_2 N_k$; the following holds:

$$|\{u \in [1 : N_i] : (\mathbf{x}_{iu}, \mathbf{x}_i, \mathbf{x}_j, \mathbf{x}_k) \in T_{X'_i X_i X_j X_k}^n\}| \leq \exp\left(n\left(|R_1 - I(X'_i; X_1 X_2 X_3)|^+ + \epsilon/2\right)\right); \quad (11)$$

$$\begin{aligned} &|\{(u, v) \in [1 : N_i] \times [1 : N_j] : (\mathbf{x}_{iu}, \mathbf{x}_{jv}, \mathbf{x}_i, \mathbf{x}_j, \mathbf{x}_k) \in T_{X'_i X'_j X_i X_j X_k}^n\}| \\ &\leq \exp\left(n\left(\left(|R_i - I(X'_i; X_i X_j X_k)|^+ + |R_j - I(X'_j; X_i X_j X_k)|^+ - I(X'_i; X'_j | X_i X_j X_k)\right|^+ + \epsilon/2\right)\right); \end{aligned} \quad (12)$$

$$\begin{aligned} &|\{(u, w) \in [1 : N_i] \times [1 : N_k] : (\mathbf{x}_{iu}, \mathbf{x}_{kw}, \mathbf{x}_i, \mathbf{x}_j, \mathbf{x}_k) \in T_{X'_i X'_j X_i X_j X_k}^n\}| \\ &\leq \exp\left(n\left(\left(|R_i - I(X'_i; X_i X_j X_k)|^+ + |R_k - I(X'_k; X_i X_j X_k)|^+ - I(X'_i; X'_k | X_i X_j X_k)\right|^+ + \epsilon/2\right)\right); \end{aligned} \quad (13)$$

$$\frac{1}{N_i N_j} |\{(r, s) \in [1 : N_i] \times [1 : N_j] : (\mathbf{x}_{ir}, \mathbf{x}_{js}, \mathbf{x}_k) \in T_{X_i X_j X_k}^n\}| < \exp\left(-\frac{n\epsilon}{2}\right), \text{ if } I(X_i; X_k) + I(X_j; X_i X_k) \geq \epsilon; \quad (14)$$

$$\begin{aligned} &\frac{1}{N_i N_j} |\{(r, s) \in [1 : N_i] \times [1 : N_j] : \exists (u, v) \in [1 : N_i] \times [1 : N_j], u \neq r, v \neq s, (\mathbf{x}_{ir}, \mathbf{x}_{js}, \mathbf{x}_{iu}, \mathbf{x}_{jv}, \mathbf{x}_k) \in T_{X_i X_j X'_i X'_j X_k}^n\}| \\ &< \exp\left(-\frac{n\epsilon}{2}\right), \end{aligned}$$

$$\text{if } I(X_i; X_j X'_i X'_j X_k) + I(X_j; X'_i X'_j X_k) \geq \left| |R_i - I(X'_i; X_k)|^+ + |R_j - I(X'_j; X_k)|^+ - I(X'_i; X'_j | X_k) \right|^+ + \epsilon; \quad (15)$$

$$\begin{aligned} &\frac{1}{N_i N_j} |\{(r, s) \in [1 : N_i] \times [1 : N_j] : \exists (u, w) \in [1 : N_i] \times [1 : N_k], u \neq r, (\mathbf{x}_{ir}, \mathbf{x}_{js}, \mathbf{x}_{iu}, \mathbf{x}_{kw}, \mathbf{x}_k) \in T_{X_i X_j X'_i X'_k X_k}^n\}| \\ &< \exp\left(-\frac{n\epsilon}{2}\right), \end{aligned}$$

$$\text{if } I(X_i; X_j X'_i X'_k X_k) + I(X_j; X'_i X'_k X_k) \geq \left| |R_i - I(X'_i; X_k)|^+ + |R_k - I(X'_k; X_k)|^+ - I(X'_i; X'_k | X_k) \right|^+ + \epsilon; \quad (16)$$

$$\frac{1}{N_i N_j} |\{(r, s) \in [1 : N_i] \times [1 : N_j] : \exists u \in [1 : N_i], u \neq r, (\mathbf{x}_{ir}, \mathbf{x}_{js}, \mathbf{x}_{iu}, \mathbf{x}_k) \in T_{X_i X_j X'_i X_k}^n\}| < \exp\left(-\frac{n\epsilon}{2}\right),$$

$$\text{if } I(X_i; X_j X'_i X_k) + I(X_j; X'_i X_k) \geq |R_i - I(X'_i; X_k)|^+ + \epsilon. \quad (17)$$

To illustrate the proof idea, we will show the analysis of statement (12), which can be obtained by a direct application of [23, Theorem 2.1]. For the complete proof, please refer to Appendix B.

Proof idea. The existence of a codebook satisfying properties (11)-(17) is shown by a random coding argument. For fixed $(\mathbf{x}_i, \mathbf{x}_j, \mathbf{x}_k) \in \mathcal{X}_i^n \times \mathcal{X}_j^n \times \mathcal{X}_k^n$ and joint type $P_{X_i X'_i X_j X'_j X_k X'_k} \in \mathcal{P}_{\mathcal{X}_i \times \mathcal{X}_i \times \mathcal{X}_j \times \mathcal{X}_j \times \mathcal{X}_k \times \mathcal{X}_k}^n$, we will show that the probability that each of the statements (11)-(17) does not hold, falls doubly exponentially in n . Since $|\mathcal{X}_i^n|$, $|\mathcal{X}_j^n|$, $|\mathcal{X}_k^n|$ and $|\mathcal{P}_{\mathcal{X}_i \times \mathcal{X}_i \times \mathcal{X}_j \times \mathcal{X}_j \times \mathcal{X}_k \times \mathcal{X}_k}^n|$ grow only exponentially in n , a union bound will imply the existence of a codebook satisfying (11)-(17). The proof will employ Lemma 11 which is obtained using [23, Theorem 2.1]. Below, we restate [23, Theorem 2.1] for a quick reference.

Lemma 5. [23, Theorem 2.1] Suppose that $V_\alpha, \alpha \in \mathcal{J}$, is a finite family of non-negative random variables and that \sim is a symmetric relation on the index set \mathcal{J} such that each V_α is independent of $\{V_\beta : \beta \not\sim \alpha\}$; in other words, the pairs (α, β) with $\alpha \sim \beta$ define the edge set of a (weak) dependency graph for the variables V_α . Let $U := \sum_\alpha V_\alpha$ and

$\mu := \mathbb{E}U = \sum_{\alpha} \mathbb{E}V_{\alpha}$. Let further, for $\alpha \in \mathcal{J}$, $\tilde{U}_{\alpha} := \sum_{\beta \sim \alpha} V_{\beta}$. If $t \geq \mu > 0$, then for every real $r > 0$,

$$\mathbb{P}(U > \mu + t) \leq e^{-r/3} + \sum_{\alpha \in \mathcal{J}} \mathbb{P}\left(\tilde{U}_{\alpha} > \frac{t}{2r}\right). \quad (18)$$

Let $T_l^n, l \in \{1, 2, 3\}$ denote the type class of P_l . We generate independent random codebooks for each user. The codebook for user $l \in \{1, 2, 3\}$, denoted by $(\mathbf{X}_{l1}, \mathbf{X}_{l2}, \dots, \mathbf{X}_{lN_l})$, consists of independent random vectors each distributed uniformly on T_l^n . Fix $(\mathbf{x}_i, \mathbf{x}_j, \mathbf{x}_k) \in \mathcal{X}_i^n \times \mathcal{X}_j^n \times \mathcal{X}_k^n$ and a joint type $P_{X_i X'_i X_j X'_j X_k X'_k} \in \mathcal{P}_{\mathcal{X}_i \times \mathcal{X}'_i \times \mathcal{X}_j \times \mathcal{X}'_j \times \mathcal{X}_k \times \mathcal{X}'_k}$ such that for $l \in \{1, 2, 3\}$, $P_{X_l} = P_{X'_l} = P_l$ and $(\mathbf{x}_i, \mathbf{x}_j, \mathbf{x}_k) \in T_{X_i X'_i X_j X'_j X_k}^n$.

In order to apply Lemma 5, let $\mathcal{J} = \{(ir, js) : (r, s) \in [1 : N_i] \times [1 : N_j]\}$. For every $(ir, js) \in \mathcal{J}$, we define binary random variable $V_{(ir, js)}$ as

$$V_{(ir, js)} = \begin{cases} 1, & \text{if } (\mathbf{X}_{ir}, \mathbf{X}_{js}) \in T_{X'_i X'_j | X_i X_j X_k}^n(\mathbf{x}_k), \\ 0, & \text{otherwise} \end{cases}$$

and $U = \sum_{(ir, js) \in \mathcal{J}} V_{(ir, js)} = \left| \left\{ (r, s) \in [1 : N_i] \times [1 : N_j] : (\mathbf{X}_{ir}, \mathbf{X}_{js}, \mathbf{x}_i, \mathbf{x}_j, \mathbf{x}_k) \in T_{X'_i X'_j | X_i X_j X_k}^n \right\} \right|$. Note that $(ir, js) \sim (iu, jv)$ if and only if $(ir, js) \cap (iu, jv) \neq \emptyset$. Thus, for $(ir, js) \in \mathcal{J}$, $\tilde{U}_{(ir, js)} = \sum_{(iu, jv) \in \mathcal{J} : (iu, jv) \cap (ir, js) \neq \emptyset} V_{(iu, jv)}$.

Next, we will compute $\mu (= \mathbb{E}[U])$. Note that

$$\begin{aligned} \mathbb{P}(V_{(ir, js)} = 1) &= \frac{|T_{X'_i X'_j | X_i X_j X_k}^n|}{|T_{X'_i}^n| |T_{X'_j}^n|} \\ &\leq \frac{\exp\{nH(X'_i X'_j | X_i X_j X_k)\}}{(n+1)^{|\mathcal{X}_i| + |\mathcal{X}_j|} \exp\{n(H(X'_i) + H(X'_j))\}} \\ &= (n+1)^{-(|\mathcal{X}_i| + |\mathcal{X}_j|)} \exp\{-n(H(X'_i X'_j) - H(X'_i X'_j | X_i X_j X_k) - H(X'_i X'_j) + H(X'_i) + H(X'_j))\} \\ &= (n+1)^{-(|\mathcal{X}_i| + |\mathcal{X}_j|)} \exp\{-n(I(X'_i X'_j; X_i X_j X_k) + I(X'_i; X'_j))\} \\ &\leq \exp\{-n(I(X'_i X'_j; X_i X_j X_k) + I(X'_i; X'_j))\} \\ &= \exp\{-n(I(X'_j; X_i X_j X_k) + I(X'_i; X_i X_j X_k | X'_j) + I(X'_i; X'_j))\} \\ &= \exp\{-n(I(X'_j; X_i X_j X_k) + I(X'_i; X'_j X_i X_k X_k))\} \end{aligned}$$

Thus,

$$\begin{aligned} \mu = \mathbb{E}[U] &= \sum_{(r, s) \in [1 : N_i] \times [1 : N_j]} \mathbb{E}[V_{(ir, js)}] = \sum_{(r, s) \in [1 : N_i] \times [1 : N_j]} \mathbb{P}(V_{(ir, js)} = 1) \\ &\leq \exp\{n(R_i + R_j - I(X'_i; X'_j X_i X_j X_k) - I(X'_i; X_i X_j X_k))\} \\ &\leq \exp\left\{n \left| |R_i - I(X'_i; X_i X_j X_k)|^+ + |R_j - I(X'_j; X_i X_j X_k)|^+ - I(X'_i; X'_j | X_i X_j X_k) \right|^+ \right\} := E. \end{aligned}$$

Let $\nu = \exp(n\epsilon/2)$. We are interested in $\mathbb{P}(U \geq \nu E)$.

$$\begin{aligned} \mathbb{P}(U \geq \nu E) &= \mathbb{P}(U - \mathbb{E}[U] \geq \nu E - \mathbb{E}[U]) \\ &\leq \mathbb{P}(U - \mathbb{E}[U] \geq \nu E - E) \\ &= \mathbb{P}(U \geq \mathbb{E}[U] + (\nu - 1)E) \\ &= \mathbb{P}(U \geq \mu + (\nu - 1)E) \end{aligned}$$

Let $t = (\nu - 1)E$ and $r = \exp(n\epsilon/8)$. We will use (18) now.

$$\mathbb{P}(U > \mu + (\nu - 1)E) \leq e^{-\frac{1}{3}\exp(n\epsilon/8)} + \sum_{(ir,js) \in \mathcal{J}} \mathbb{P}\left(\tilde{U}_{(ir,js)} > \frac{(\nu - 1)E}{2\exp(n\epsilon/8)}\right). \quad (19)$$

We need to analyze $\mathbb{P}\left(\tilde{U}_{(ir,js)} > \frac{(\nu - 1)E}{2\exp(n\epsilon/8)}\right)$.

$$\begin{aligned} & \mathbb{P}\left(\tilde{U}_{(ir,js)} > \frac{(\nu - 1)E}{2\exp(n\epsilon/8)}\right) \\ &= \mathbb{P}\left(\sum_{(iu,jv) \in \mathcal{J}: (iu,jv) \cap (ir,js) \neq \emptyset} V_{(iu,jv)} > \frac{(\nu - 1)E}{2\exp(n\epsilon/8)}\right) \\ &= \mathbb{P}\left(V_{(ir,js)} + \sum_{v \neq s} V_{(ir,jv)} + \sum_{u \neq r} V_{(iu,js)} > \frac{(\nu - 1)E}{2\exp(n\epsilon/8)}\right) \\ &= \mathbb{P}\left(\sum_{v \neq s} V_{(ir,jv)} + \sum_{u \neq r} V_{(iu,js)} > \frac{(\nu - 1)E}{2\exp(n\epsilon/8)} - V_{(ir,js)}\right) \\ &\leq \mathbb{P}\left(\sum_{v \neq s} V_{(ir,jv)} + \sum_{u \neq r} V_{(iu,js)} > \frac{(\nu - 1)E}{2\exp(n\epsilon/8)} - 1\right) \\ &\leq \mathbb{P}\left(\sum_{v \neq s} V_{(ir,jv)} > \frac{1}{2}\left(\frac{(\nu - 1)E}{2\exp(n\epsilon/8)} - 1\right)\right) + \mathbb{P}\left(\sum_{u \neq r} V_{(iu,js)} > \frac{1}{2}\left(\frac{(\nu - 1)E}{2\exp(n\epsilon/8)} - 1\right)\right) \end{aligned}$$

The last inequality uses a union bound. Note that

$$\begin{aligned} \frac{1}{2}\left(\frac{(\nu - 1)E}{2\exp(n\epsilon/8)} - 1\right) &= \frac{1}{2}\left(\frac{(\exp(n\epsilon/2) - 1)E}{2\exp(n\epsilon/8)} - 1\right) \\ &\geq \frac{1}{2}\left(\frac{(\exp(n\epsilon/2) - 1)E}{2\exp(n\epsilon/8)} - E\right) \\ &= \frac{1}{2}\left(\left(\frac{(\exp(n\epsilon/2) - 1)}{2\exp(n\epsilon/8)} - 1\right)E\right) \\ &\geq \left(\frac{\exp(3n\epsilon/8)}{\exp(n\epsilon/8)}\right)E \text{ for large } n \\ &= \exp(n\epsilon/4). \end{aligned}$$

Thus,

$$\begin{aligned} & \mathbb{P}\left(\sum_{v \neq s} V_{(ir,jv)} > \frac{1}{2}\left(\frac{(\nu - 1)E}{2\exp(n\epsilon/4)} - 1\right)\right) + \mathbb{P}\left(\sum_{u \neq r} V_{(iu,js)} > \frac{1}{2}\left(\frac{(\nu - 1)E}{2\exp(n\epsilon/4)} - 1\right)\right) \\ &\leq \mathbb{P}\left(\sum_{v \neq s} V_{(ir,jv)} > \exp(n\epsilon/4)E\right) + \mathbb{P}\left(\sum_{u \neq r} V_{(iu,js)} > \exp(n\epsilon/4)E\right). \end{aligned}$$

Let us first analyze $\mathbb{P}\left(\sum_{v \neq s} V_{(ir,jv)} > \exp(n\epsilon/4)E\right)$.

$$\mathbb{P}\left(\sum_{v \neq s} V_{(ir,jv)} > \exp(n\epsilon/4)E\right) = \sum_{\mathbf{x}_{js} \in T_{X'_j|X_iX_jX_k}^n(\mathbf{x}_i, \mathbf{x}_j, \mathbf{x}_k)} \mathbb{P}(\mathbf{X}_{js} = \mathbf{x}_{js}) \mathbb{P}\left(\sum_{v \neq s} V_{(ir,jv)} > \exp(n\epsilon/4)E \mid \mathbf{X}_{js} = \mathbf{x}_{js}\right)$$

We will apply Lemma 5 on $\mathbb{P}\left(\sum_{v \neq s} V_{(ir,jv)} > \exp(n\epsilon/8)E \mid \mathbf{X}_{js} = \mathbf{x}_{js}\right)$ for $\mathcal{J}' = \{(ir, jv) : v \in [1 : N_j] \setminus \{s\}\}$. For every $(ir, jv) \in \mathcal{J}'$, we define binary random variable $V'_{(ir,jv)}$ as

$$V'_{(ir,jv)} = \begin{cases} 1, & \text{if } (\mathbf{X}_{jv}) \in T_{X'_j|X'_iX_iX_jX_k}^n(\mathbf{x}_{ir}, \mathbf{x}_i, \mathbf{x}_j, \mathbf{x}_k), \\ 0, & \text{otherwise} \end{cases}$$

and $U' = \sum_{(ir,jv) \in \mathcal{J}'} V'_{(ir,jv)}$. Note that $(ir, jv) \sim (iu, jv')$ if and only if $v = v'$. Next, we will compute $\mathbb{E}[U']$.

$$\begin{aligned} \mathbb{E}[U'] &= \mathbb{E}\left[\sum_{(ir,jv) \in \mathcal{J}'} V'_{(ir,jv)}\right] \\ &\leq \sum_{v \neq s} \mathbb{P}\left(V'_{(ir,jv)} = 1\right) \\ &= \sum_{v \neq s} \mathbb{P}\left(\mathbf{X}_{jv} \in T_{X'_j|X'_iX_iX_jX_k}^n(\mathbf{x}_{ir}, \mathbf{x}_i, \mathbf{x}_j, \mathbf{x}_k)\right) \\ &= \sum_{v \neq s} \frac{|T_{X'_j|X'_iX_iX_jX_k}^n|}{|T_{X'_j}^n|} \\ &\leq \exp\{nR_j\} \frac{\exp\{nH(X'_j|X'_iX_iX_jX_k)\}}{(n+1)^{|\mathcal{X}_j|} \exp\{nH(X'_j)\}} \\ &\leq \exp\{n(|R_j - I(X'_j; X'_iX_iX_jX_k)|^+)\} \\ &\leq E. \end{aligned}$$

Now,

$$\begin{aligned} \mathbb{P}\left(\sum_{v \neq s} V_{(ir,jv)} > \exp(n\epsilon/4)E \mid \mathbf{X}_{js} = \mathbf{x}_{js}\right) &= \mathbb{P}\left(\sum_{(ir,jv) \in \mathcal{J}'} V'_{(ir,jv)} > \exp(n\epsilon/4)E\right) \\ &= \mathbb{P}(U' > \mathbb{E}(U') + \exp(n\epsilon/4)E - \mathbb{E}(U')) \\ &\stackrel{(a)}{\leq} \mathbb{P}(U' > \mathbb{E}(U') + (\exp(n\epsilon/4) - 1)E) \\ &\stackrel{(b)}{\leq} e^{-\frac{1}{3}\exp(n\epsilon/8)} + \sum_{(ir,jv) \in \mathcal{J}'} \mathbb{P}\left(V'_{(ir,jv)} > \frac{(\exp(n\epsilon/4) - 1)E}{2\exp(n\epsilon/8)}\right) \\ &\stackrel{(c)}{\leq} e^{-\frac{1}{3}\exp(n\epsilon/8)} + \sum_{(ir,jv) \in \mathcal{J}'} \mathbb{P}\left(V'_{(ir,jv)} > E\right) \text{ for large } n \\ &\stackrel{(d)}{\leq} e^{-\frac{1}{3}\exp(n\epsilon/8)} \end{aligned}$$

where (a) holds because $\mathbb{E}[U'] \leq E$, (b) uses (18) for $r = \exp(n\epsilon/8)$, (c) is true for large n and (d) holds because $V'_{(ir,jv)} \in \{0, 1\}$ while $E \geq 1$. Thus,

$$\mathbb{P}\left(\sum_{v \neq s} V_{(ir,jv)} > \exp(n\epsilon/4)E\right) \leq e^{-\frac{1}{3}\exp(n\epsilon/8)}$$

. Similarly,

$$\mathbb{P}\left(\sum_{u \neq r} V_{(iu,js)} > \exp(n\epsilon/4)E\right) \leq e^{-\frac{1}{3}\exp(n\epsilon/8)}$$

. This implies that

$$\mathbb{P}\left(\tilde{U}_{(ir,js)} > \frac{(\nu-1)E}{2\exp(n\epsilon/8)}\right) \leq 2e^{-\frac{1}{3}\exp(n\epsilon/8)}.$$

Thus, from (19),

$$\begin{aligned} \mathbb{P}(U > \mu + (\nu-1)E) &\leq e^{-\frac{1}{3}\exp(n\epsilon/8)} + |\mathcal{J}|2e^{-\frac{1}{3}\exp(n\epsilon/8)} \\ &= e^{-\frac{1}{3}\exp(n\epsilon/8)} + |N_i||N_j|2e^{-\frac{1}{3}\exp(n\epsilon/8)} \end{aligned}$$

which falls doubly exponentially. \square

Proof (Achievability of Theorem 1). Our achievability uses the concentration result from [23] and is along the line of arguments in [10, 11, 22]. Below, we repeat the decoder from section 3.2.1.4 for the sake of completeness.

Definition 6 (Decoder). For a received vector $\mathbf{y} \in \mathcal{Y}^n$, some $\eta > 0$, $\phi(\mathbf{y}) = (m_1, m_2, m_3) \in \mathcal{M}_1 \times \mathcal{M}_2 \times \mathcal{M}_3$, if $\mathbf{y} \in \mathcal{D}_{m_1}^{(1)} \cap \mathcal{D}_{m_2}^{(2)} \cap \mathcal{D}_{m_3}^{(3)}$ where $\mathcal{D}_{m_i}^{(i)}$, $i = 1, 2, 3$ is defined as below.

$\mathbf{y} \in \mathcal{D}_{m_1}^{(1)}$ if there exists some permutation (j, k) of $(2, 3)$, $m_j \in \mathcal{M}_j$, $\mathbf{x}_k \in \mathcal{X}_k^n$, and random variables X_1, X_j, X_k with $(f_1(m_1), f_j(m_j), \mathbf{x}_k, \mathbf{y}) \in T_{X_1 X_j X_k Y}^n$ and $D(P_{X_1 X_j X_k Y} \| P_{X_1} \times P_{X_j} \times P_{X_k} \times W) < \eta$ such that the following hold:

- (a) Disambiguating (m_1, m_j) from (m'_1, m'_j) : For every $(m'_1, m'_j) \in \mathcal{M}_1 \times \mathcal{M}_j$, $m'_1 \neq m_1$, $m'_j \neq m_j$, $\mathbf{x}'_k \in \mathcal{X}_k^n$, and random variables X'_1, X'_j, X'_k such that $(f_1(m_1), f_1(m'_1), f_j(m_j), f_j(m'_j), \mathbf{x}_k, \mathbf{x}'_k, \mathbf{y}) \in T_{X_1 X'_1 X_j X'_j X_k X'_k Y}^n$ and $D(P_{X'_1 X'_j X'_k Y} \| P_{X'_1} \times P_{X'_j} \times P_{X'_k} \times W) < \eta$, we require that $I(X_1 X_j Y; X'_1 X'_j | X_k) < \eta$.
- (b) Disambiguating m_1 from m'_1 : For every $m'_1 \in \mathcal{M}_1$, $m'_1 \neq m_1$, $\mathbf{x}'_k \in \mathcal{X}_k^n$, and random variables X'_1, X'_k such that $(f_1(m_1), f_1(m'_1), f_j(m_j), \mathbf{x}_k, \mathbf{x}'_k, \mathbf{y}) \in T_{X_1 X'_1 X_j X_k X'_k Y}^n$ and $D(P_{X'_1 X_j X'_k Y} \| P_{X'_1} \times P_{X_j} \times P_{X'_k} \times W) < \eta$, we require that $I(X_1 X_j Y; X'_1 | X_k) < \eta$.
- (c) Disambiguating (m_1, m_j) from (m'_1, m_k) : If there exist $(m'_1, m_k) \in \mathcal{M}_1 \times \mathcal{M}_k$, $m'_1 \neq m_1$, $\mathbf{x}_j \in \mathcal{X}_j^n$, and random variables X'_1, X'_j, X'_k such that $(f_1(m_1), f_1(m'_1), f_j(m_j), \mathbf{x}_j, \mathbf{x}_k, f_k(m_k), \mathbf{y}) \in T_{X_1 X'_1 X_j X'_j X_k X'_k Y}^n$ and $D(P_{X'_1 X'_j X'_k Y} \| P_{X'_1} \times P_{X'_j} \times P_{X'_k} \times W) < \eta$, we require that $I(X_1 X_j Y; X'_1 X'_j | X_k) < \eta$.

The decoding sets $\mathcal{D}_{m_2}^{(2)}$ and $\mathcal{D}_{m_3}^{(3)}$ are defined similarly. If $\mathbf{y} \notin \mathcal{D}_{m_1}^{(1)} \cap \mathcal{D}_{m_2}^{(2)} \cap \mathcal{D}_{m_3}^{(3)}$ for any $(m_1, m_2, m_3) \in \mathcal{M}_1 \times \mathcal{M}_2 \times \mathcal{M}_3$, the decoder outputs $(1, 1, 1)$.

Next, we give some standard properties of joint types as given in [22] (as *Fact 1*, *Fact 2* and *Fact 3*). As mentioned in [22], these bounds can be found in [27]. For finite alphabets \mathcal{X} , \mathcal{Y} , the type class $\mathcal{P}_{\mathcal{X}}^n$, any channel V from \mathcal{X} to \mathcal{Y} and random variables X and Y on \mathcal{X} and \mathcal{Y} respectively with joint distribution P_{XY} , the following holds:

$$|\mathcal{P}_{\mathcal{X}}^n| \leq (n+1)^{|\mathcal{X}|} \tag{20}$$

$$(n+1)^{-|\mathcal{X}|} \exp(nH(X)) \leq |T_X^n(\mathbf{x})| \leq \exp(nH(X)) \quad \text{if } |T_X^n(\mathbf{x})| \neq 0 \quad (21)$$

$$(n+1)^{-|\mathcal{X}||\mathcal{Y}|} \exp(nH(Y|X)) \leq |T_{Y|X}^n(\mathbf{x})| \leq \exp(nH(Y|X)) \quad \text{if } |T_{Y|X}^n(\mathbf{x})| \neq 0 \quad (22)$$

$$\sum_{\mathbf{y} \in T_{Y|X}^n(\mathbf{x})} V^n(\mathbf{y}|\mathbf{x}) \leq \exp(-nD(P_{XY} \| P_X \times V)) \quad (23)$$

Fix distributions $P_1 \in \mathcal{P}_{\mathcal{X}_1}^n$, $P_2 \in \mathcal{P}_{\mathcal{X}_2}^n$ and $P_3 \in \mathcal{P}_{\mathcal{X}_3}^n$. For these distributions, consider the codebook given by Lemma 4 and the decoder as given in Definition 6 for some $\eta > 0$ (TBD) satisfying the condition in Lemma 2.

We first analyze the case when user 3 is adversarial. The probability of error when one user is adversarial (see (1)) is given by

$$P_{e,3} \stackrel{\text{def}}{=} \max_{\mathbf{x}_3} \frac{1}{N_1 N_2} \sum_{r \in \mathcal{M}_1, s \in \mathcal{M}_2} \mathbb{P}\left(\{\mathbf{y} : \phi(\mathbf{y}) \neq (r, s, t) \text{ for all } t \in \mathcal{M}_3\} \mid \mathbf{X}_1 = \mathbf{x}_{1r}, \mathbf{X}_2 = \mathbf{x}_{2s}, \mathbf{X}_3 = \mathbf{x}_3\right).$$

From the decoder definition, we know that for $(r, s) \in \mathcal{M}_1 \times \mathcal{M}_2$, if $\phi(\mathbf{y}) \neq (r, s, t)$ for any $t \in \mathcal{M}_3$, then $\mathbf{y} \notin \mathcal{D}_r^{(1)} \cap \mathcal{D}_s^{(2)}$. In other words, $\mathbf{y} \in (\mathcal{D}_r^{(1)})^c \cup (\mathcal{D}_s^{(2)})^c$. Thus,

$$\begin{aligned} P_{e,3} &\stackrel{\text{def}}{=} \max_{\mathbf{x}_3} \frac{1}{N_1 N_2} \sum_{r \in \mathcal{M}_1, s \in \mathcal{M}_2} \mathbb{P}\left(\{\mathbf{y} : \mathbf{y} \in (\mathcal{D}_r^{(1)})^c \cup (\mathcal{D}_s^{(2)})^c\} \mid \mathbf{X}_1 = \mathbf{x}_{1r}, \mathbf{X}_2 = \mathbf{x}_{2s}, \mathbf{X}_3 = \mathbf{x}_3\right) \\ &= \max_{\mathbf{x}_3} \frac{1}{N_1 N_2} \sum_{r \in \mathcal{M}_1, s \in \mathcal{M}_2} \mathbb{P}\left(\{\mathbf{y} : \mathbf{y} \in (\mathcal{D}_r^{(1)})^c\} \cup \{\mathbf{y} : \mathbf{y} \in (\mathcal{D}_s^{(2)})^c\} \mid \mathbf{X}_1 = \mathbf{x}_{1r}, \mathbf{X}_2 = \mathbf{x}_{2s}, \mathbf{X}_3 = \mathbf{x}_3\right) \\ &\stackrel{(a)}{\leq} \max_{\mathbf{x}_3} \left\{ \frac{1}{N_1 N_2} \sum_{r \in \mathcal{M}_1, s \in \mathcal{M}_2} \mathbb{P}\left(\{\mathbf{y} : \mathbf{y} \in (\mathcal{D}_r^{(1)})^c\} \mid \mathbf{X}_1 = \mathbf{x}_{1r}, \mathbf{X}_2 = \mathbf{x}_{2s}, \mathbf{X}_3 = \mathbf{x}_3\right) \right. \\ &\quad \left. + \frac{1}{N_1 N_2} \sum_{r \in \mathcal{M}_1, s \in \mathcal{M}_2} \mathbb{P}\left(\{\mathbf{y} : \mathbf{y} \in (\mathcal{D}_s^{(2)})^c\} \mid \mathbf{X}_1 = \mathbf{x}_{1r}, \mathbf{X}_2 = \mathbf{x}_{2s}, \mathbf{X}_3 = \mathbf{x}_3\right) \right\} \end{aligned}$$

where (a) uses union bound.

This gives the following upper bound on $P_{e,3}$.

$$\begin{aligned} P_{e,3} &\leq \max_{\mathbf{x}_3} \left\{ \frac{1}{N_1 N_2} \sum_{r \in \mathcal{M}_1, s \in \mathcal{M}_2} \mathbb{P}\left(\{\mathbf{y} : \mathbf{y} \notin \mathcal{D}_r^{(1)}\} \mid X_1^n = \mathbf{x}_{1r}, X_2^n = \mathbf{x}_{2s}, X_3^n = \mathbf{x}_3\right) \right. \\ &\quad \left. + \frac{1}{N_1 N_2} \sum_{r \in \mathcal{M}_1, s \in \mathcal{M}_2} \mathbb{P}\left(\{\mathbf{y} : \mathbf{y} \notin \mathcal{D}_s^{(2)}\} \mid X_1^n = \mathbf{x}_{1r}, X_2^n = \mathbf{x}_{2s}, X_3^n = \mathbf{x}_3\right) \right\}. \quad (24) \end{aligned}$$

Let

$$\mathcal{A}_\epsilon \stackrel{\text{def}}{=} \{P_{X_1 X_2 X_3 Y} \in \mathcal{P}_{\mathcal{X}_1 \times \mathcal{X}_2 \times \mathcal{X}_3 \times \mathcal{Y}}^n : I(X_1; X_3) + I(X_2; X_1 X_3) > \epsilon\} \text{ and}$$

$$\mathcal{D}_\eta \stackrel{\text{def}}{=} \{P_{X_1 X_2 X_3 Y} \in \mathcal{P}_{\mathcal{X}_1 \times \mathcal{X}_2 \times \mathcal{X}_3 \times \mathcal{Y}}^n : D(P_{X_1 X_2 X_3 Y} \| P_{X_1} P_{X_2} P_{X_3} W) \leq \eta\}.$$

We will use \mathcal{A}_ϵ^c and \mathcal{D}_η^c to denote $\mathcal{P}_{\mathcal{X}_1 \times \mathcal{X}_2 \times \mathcal{X}_3 \times \mathcal{Y}}^n \setminus \mathcal{A}_\epsilon$ and $\mathcal{P}_{\mathcal{X}_1 \times \mathcal{X}_2 \times \mathcal{X}_3 \times \mathcal{Y}}^n \setminus \mathcal{D}_\eta$ respectively. Let us focus on the first term on the RHS of (24).

$$\frac{1}{N_1 N_2} \sum_{(r,s)} \mathbb{P}\left(\{\mathbf{y} : \mathbf{y} \notin \mathcal{D}_r^{(1)}\} \mid X_1^n = \mathbf{x}_{1r}, X_2^n = \mathbf{x}_{2s}, X_3^n = \mathbf{x}_3\right)$$

$$\begin{aligned}
&\leq \frac{1}{N_1 N_2} \sum_{P_{X_1 X_2 X_3 Y} \in \mathcal{A}_\epsilon} \sum_{\substack{(r,s): \\ (\mathbf{x}_{1r}, \mathbf{x}_{2s}) \in T_{X_1 X_2 | X_3}^n(\mathbf{x}_3^n)}} 1 \\
&+ \frac{1}{N_1 N_2} \sum_{P_{X_1 X_2 X_3 Y} \in \mathcal{A}_\epsilon^c \cap \mathcal{D}_\eta^c} \sum_{\substack{(r,s): \\ (\mathbf{x}_{1r}, \mathbf{x}_{2s}, \mathbf{x}_3) \in T_{X_1 X_2 X_3}^n}} \sum_{\mathbf{y} \in T_{Y | X_1 X_2 X_3}^n(\mathbf{x}_{1r}, \mathbf{x}_{2s}, \mathbf{x}_3)} W^n(\mathbf{y} | \mathbf{x}_{1r}, \mathbf{x}_{2s}, \mathbf{x}_3) \\
&+ \frac{1}{N_1 N_2} \sum_{P_{X_1 X_2 X_3 Y} \in \mathcal{A}_\epsilon^c \cap \mathcal{D}_\eta} \sum_{\substack{(r,s): \\ (\mathbf{x}_{1r}, \mathbf{x}_{2s}, \mathbf{x}_3) \in T_{X_1 X_2 X_3}^n}} \sum_{\substack{\mathbf{y} \in T_{Y | X_1 X_2 X_3}^n(\mathbf{x}_{1r}, \mathbf{x}_{2s}, \mathbf{x}_3) \\ \mathbf{y} \notin \mathcal{D}_r^{(1)}}} W^n(\mathbf{y} | \mathbf{x}_{1r}, \mathbf{x}_{2s}, \mathbf{x}_3). \quad (25)
\end{aligned}$$

We will analyze each term on the RHS of (25) separately. We start with the first term.

$$\begin{aligned}
&\frac{1}{N_1 N_2} \sum_{P_{X_1 X_2 X_3 Y} \in \mathcal{A}_\epsilon} \sum_{\substack{(r,s): \\ (\mathbf{x}_{1r}, \mathbf{x}_{2s}) \in T_{X_1 X_2 | X_3}^n(\mathbf{x}_3^n)}} 1 \\
&= \frac{1}{N_1 N_2} \sum_{P_{X_1 X_2 X_3 Y} \in \mathcal{A}_\epsilon} |\{(r, s) : (\mathbf{x}_{1r}, \mathbf{x}_{2s}, \mathbf{x}_3) \in T_{X_1 X_2 X_3}^n\}| \\
&= \sum_{P_{X_1 X_2 X_3 Y} \in \mathcal{A}_\epsilon} \frac{|\{(r, s) : (\mathbf{x}_{1r}, \mathbf{x}_{2s}, \mathbf{x}_3) \in T_{X_1 X_2 X_3}^n\}|}{N_1 N_2} \\
&\stackrel{(a)}{\leq} \sum_{P_{X_1 X_2 X_3 Y} \in \mathcal{A}_\epsilon} \exp(-n\epsilon/2) \\
&\leq |\mathcal{P}_{\mathcal{X}_1 \times \mathcal{X}_2 \times \mathcal{X}_3 \times \mathcal{Y}}^n| \exp(-n\epsilon/2) \\
&\stackrel{(b)}{\leq} (n+1)^{|\mathcal{X}_1 \times \mathcal{X}_2 \times \mathcal{X}_3 \times \mathcal{Y}|} \exp(-n\epsilon/2) \\
&\rightarrow 0 \text{ as } n \rightarrow \infty.
\end{aligned}$$

Here, (a) follows from (14) (as $I(X_1; X_3) + I(X_2; X_1 X_3) > \epsilon$ for every $P_{X_1 X_2 X_3 Y} \in \mathcal{A}_\epsilon$). The inequality (b) uses (20). We now analyze the second term. For fixed $r \in [1 : N_1]$ and $s \in [1 : N_2]$

$$\begin{aligned}
&\sum_{\substack{P_{X_1 X_2 X_3 Y} \in \mathcal{A}_\epsilon^c \cap \mathcal{D}_\eta^c: \\ (\mathbf{x}_{1r}, \mathbf{x}_{2s}, \mathbf{x}_3) \in T_{X_1 X_2 X_3}^n}} \sum_{\mathbf{y} \in T_{Y | X_1 X_2 X_3}^n(\mathbf{x}_{1r}, \mathbf{x}_{2s}, \mathbf{x}_3)} W^n(\mathbf{y} | \mathbf{x}_{1r}, \mathbf{x}_{2s}, \mathbf{x}_3) \\
&\stackrel{(a)}{\leq} \sum_{\substack{P_{X_1 X_2 X_3 Y} \in \mathcal{A}_\epsilon^c \cap \mathcal{D}_\eta^c: \\ (\mathbf{x}_{1r}, \mathbf{x}_{2s}, \mathbf{x}_3) \in T_{X_1 X_2 X_3}^n}} \exp(-nD(P_{X_1 X_2 X_3 Y} || P_{X_1 X_2 X_3} W)) \\
&= \sum_{\substack{P_{X_1 X_2 X_3 Y} \in \mathcal{A}_\epsilon^c \cap \mathcal{D}_\eta^c: \\ (\mathbf{x}_{1r}, \mathbf{x}_{2s}, \mathbf{x}_3) \in T_{X_1 X_2 X_3}^n}} \exp(-n(D(P_{X_1 X_2 X_3 Y} || P_{X_1} P_{X_2} P_{X_3} W) - I(X_1 X_2; X_3) - I(X_1; X_2))) \\
&\stackrel{(b)}{\leq} \sum_{\substack{P_{X_1 X_2 X_3 Y} \in \mathcal{A}_\epsilon^c \cap \mathcal{D}_\eta^c: \\ (\mathbf{x}_{1r}, \mathbf{x}_{2s}, \mathbf{x}_3) \in T_{X_1 X_2 X_3}^n}} \exp(-n(\eta - \epsilon)) \\
&\leq |\mathcal{P}_{\mathcal{X}_1 \times \mathcal{X}_2 \times \mathcal{X}_3 \times \mathcal{Y}}^n| \exp(-n(\eta - \epsilon)) \\
&\stackrel{(c)}{\leq} (n+1)^{|\mathcal{X}_1 \times \mathcal{X}_2 \times \mathcal{X}_3 \times \mathcal{Y}|} \exp(-n(\eta - \epsilon))
\end{aligned}$$

$\rightarrow 0$ as $n \rightarrow \infty$ when $\eta > \epsilon$.

Here, the inequality (a) uses (23), (b) follows by noting that $P_{X_1 X_2 X_3 Y} \in \mathcal{A}_\epsilon^c \cap \mathcal{D}_\eta^c$ and thus, $D(P_{X_1 X_2 X_3 Y} \| P_{X_1} P_{X_2} P_{X_3} W) > \eta$ and $I(X_1 X_2; X_3) + I(X_1; X_2) \leq \epsilon$. The inequality (c) follows because $\mathcal{P}_{\mathcal{X}_1 \times \mathcal{X}_2 \times \mathcal{X}_3 \times \mathcal{Y}}^n \leq (n+1)^{|\mathcal{X}_1 \times \mathcal{X}_2 \times \mathcal{X}_3 \times \mathcal{Y}|}$ by using (20). This shows that the second term on the RHS of (25) also goes to zero as n goes to infinity.

It remains to analyze the third term of (25). Note that in Definition 6, for $(j, k) = (2, 3)$, $(\mathbf{x}_{1r}, \mathbf{x}_{2s}, \mathbf{x}_3, \mathbf{y}) \in T_{X_1 X_2 X_3 Y}^n$, $P_{X_1 X_2 X_3 Y}$ satisfies $D(P_{X_1 X_2 X_3 Y} \| P_{X_1} \times P_{X_2} \times P_{X_3} \times W) < \eta$. Still, if $\mathbf{y} \notin \mathcal{D}_r^{(1)}$, then at least one of the conditions (a)-(c) is violated. This implies that at least one of the following holds:

- (a) There exists $u \in \mathcal{M}_1$, $u \neq r$, $v \in \mathcal{M}_2$, $v \neq s$, $\mathbf{x}'_3 \in \mathcal{X}_3^n$, and random variables X'_1, X'_2, X'_3 such that $(f_1(r), f_2(s), \mathbf{x}_3, f_1(u), f_2(v), \mathbf{x}'_3, \mathbf{y}) \in T_{X_1 X_2 X_3 X'_1 X'_2 X'_3 Y}^n$, $D(P_{X'_1 X'_2 X'_3 Y} \| P_{X'_1} P_{X'_2} P_{X'_3} W) < \eta$ and $I(X_1 X_2 Y; X'_1 X'_2 | X_3) \geq \eta$.
- (b) There exists $u \in \mathcal{M}_1$, $u \neq r$, $\mathbf{x}'_3 \in \mathcal{X}_3^n$, and random variables X'_1, X'_3 such that $(f_1(r), f_2(s), \mathbf{x}_3, f_1(u), \mathbf{x}'_3, \mathbf{y}) \in T_{X_1 X_2 X_3 X'_1 X'_3 Y}^n$, $D(P_{X'_1 X_2 X'_3 Y} \| P_{X'_1} P_{X_2} P_{X'_3} W) < \eta$ and $I(X_1 X_2 Y; X'_1 | X_3) \geq \eta$.
- (c) There exists $u \in \mathcal{M}_1$, $u \neq r$, $\mathbf{x}_2 \in \mathcal{X}_2^n$, $w \in \mathcal{M}_3$, and random variables X'_1, X'_2, X'_3 such that $(f_1(r), f_2(s), \mathbf{x}_3, f_1(u), \mathbf{x}_2, f_3(w), \mathbf{y}) \in T_{X_1 X_2 X_3 X'_1 X'_2 X'_3 Y}^n$, $D(P_{X'_1 X'_2 X'_3 Y} \| P_{X'_1} P_{X_2} P_{X'_3} W) < \eta$ and $I(X_1 X_2 Y; X'_1 X'_3 | X_3) \geq \eta$.

To analyze these, we define the following sets of distributions:

$$\begin{aligned} \mathcal{Q}_1 &= \{P_{X_1 X_2 X_3 X'_1 X'_2 Y} \in \mathcal{P}_{\mathcal{X}_1 \times \mathcal{X}_2 \times \mathcal{X}_3 \times \mathcal{X}_1 \times \mathcal{X}_2 \times \mathcal{Y}}^n : P_{X_1 X_2 X_3 Y} \in \mathcal{D}_\eta \cap \mathcal{A}_\epsilon^c, P_{X'_1 X'_2 X'_3 Y} \in \mathcal{D}_\eta \\ &\quad \text{for some } X'_3, P_{X_1} = P_{X'_1} = P_1, P_{X_2} = P_{X'_2} = P_2 \text{ and } I(X_1 X_2 Y; X'_1 X'_2 | X_3) \geq \eta\} \\ \mathcal{Q}_2 &= \{P_{X_1 X_2 X_3 X'_1 Y} \in \mathcal{P}_{\mathcal{X}_1 \times \mathcal{X}_2 \times \mathcal{X}_3 \times \mathcal{X}_1 \times \mathcal{X}_3 \times \mathcal{Y}}^n : P_{X_1 X_2 X_3 Y} \in \mathcal{D}_\eta \cap \mathcal{A}_\epsilon^c, P_{X'_1 X_2 X'_3 Y} \in \mathcal{D}_\eta \\ &\quad \text{for some } X'_3, P_{X_1} = P_{X'_1} = P_1, P_{X_2} = P_2 \text{ and } I(X_1 X_2 Y; X'_1 | X_3) \geq \eta\} \\ \mathcal{Q}_3 &= \{P_{X_1 X_2 X_3 X'_1 X'_2 Y} \in \mathcal{P}_{\mathcal{X}_1 \times \mathcal{X}_2 \times \mathcal{X}_3 \times \mathcal{X}_1 \times \mathcal{X}_3 \times \mathcal{Y}}^n : P_{X_1 X_2 X_3 Y} \in \mathcal{D}_\eta \cap \mathcal{A}_\epsilon^c, P_{X'_1 X'_2 X'_3 Y} \in \mathcal{D}_\eta \\ &\quad \text{for some } X'_2, P_{X_1} = P_{X'_1} = P_1, P_{X_2} = P_2, P_{X'_3} = P_3 \text{ and } I(X_1 X_2 Y; X'_1 X'_3 | X_3) \geq \eta\} \end{aligned}$$

For $r, s \in \mathcal{M}_1 \times \mathcal{M}_2$, $P_{X_1 X_2 X_3 X'_1 X'_2 Y} \in \mathcal{Q}_1$, $P_{X_1 X_2 X_3 X'_1 Y} \in \mathcal{Q}_2$ and $P_{X_1 X_2 X_3 X'_1 X'_3 Y} \in \mathcal{Q}_3$, define the following sets:

$$\begin{aligned} \mathcal{E}_{r,s,1}(P_{X_1 X_2 X_3 X'_1 X'_2 Y}) &= \{\mathbf{y} : \exists (u, v) \in \mathcal{M}_1 \times \mathcal{M}_2, u \neq r, v \neq s, (\mathbf{x}_{1r}, \mathbf{x}_{2s}, \mathbf{x}_3, \mathbf{x}_{1u}, \mathbf{x}_{2v}, \mathbf{y}) \in T_{X_1 X_2 X_3 X'_1 X'_2 Y}^n\} \\ \mathcal{E}_{r,s,2}(P_{X_1 X_2 X_3 X'_1 Y}) &= \{\mathbf{y} : \exists u \in \mathcal{M}_1, u \neq r, (\mathbf{x}_{1r}, \mathbf{x}_{2s}, \mathbf{x}_3, \mathbf{x}_{1u}, \mathbf{y}) \in T_{X_1 X_2 X_3 X'_1 Y}^n\} \\ \mathcal{E}_{r,s,3}(P_{X_1 X_2 X_3 X'_1 X'_3 Y}) &= \{\mathbf{y} : \exists (u, t) \in \mathcal{M}_1 \times \mathcal{M}_3, u \neq r, (\mathbf{x}_{1r}, \mathbf{x}_{2s}, \mathbf{x}_3, \mathbf{x}_{1u}, \mathbf{x}_{3t}, \mathbf{y}) \in T_{X_1 X_2 X_3 X'_1 X'_3 Y}^n\} \end{aligned}$$

Thus,

$$\begin{aligned} &\frac{1}{N_1 N_2} \sum_{r,s} \sum_{\substack{P_{X_1 X_2 X_3 Y} \in \mathcal{D}_\eta: \\ (\mathbf{x}_{1r}, \mathbf{x}_{2s}, \mathbf{x}_3) \in T_{X_1 X_2 X_3}^n}} \sum_{\substack{\mathbf{y} \in T_{X_1 X_2 X_3}^n(\mathbf{x}_{1r}, \mathbf{x}_{2s}, \mathbf{x}_3) \\ \mathbf{y} \notin \mathcal{D}_r^{(1)}}} W^n(\mathbf{y} | \mathbf{x}_{1r}, \mathbf{x}_{2s}, \mathbf{x}_3) \\ &\leq \frac{1}{N_1 N_2} \sum_{r,s} \left\{ \sum_{P_{X_1 X_2 X_3 X'_1 X'_2 Y} \in \mathcal{Q}_1} W^n(\mathcal{E}_{r,s,1}(P_{X_1 X_2 X_3 X'_1 X'_2 Y}) | \mathbf{x}_{1r}, \mathbf{x}_{2s}, \mathbf{x}_3) \right. \\ &\quad + \sum_{P_{X_1 X_2 X_3 X'_1 Y} \in \mathcal{Q}_2} W^n(\mathcal{E}_{r,s,2}(P_{X_1 X_2 X_3 X'_1 Y}) | \mathbf{x}_{1r}, \mathbf{x}_{2s}, \mathbf{x}_3) \\ &\quad \left. + \sum_{P_{X_1 X_2 X_3 X'_1 X'_3 Y} \in \mathcal{Q}_3} W^n(\mathcal{E}_{r,s,3}(P_{X_1 X_2 X_3 X'_1 X'_3 Y}) | \mathbf{x}_{1r}, \mathbf{x}_{2s}, \mathbf{x}_3) \right\}. \end{aligned} \tag{26}$$

We have three terms in the summation on the RHS of the above equation. We will analyze them one after the other. We will start with the first term

$$\sum_{P_{X_1 X_2 X_3 X'_1 X'_2 Y} \in \mathcal{Q}_1} \frac{1}{N_1 N_2} \sum_{r,s} W^n(\mathcal{E}_{r,s,1}(P_{X_1 X_2 X_3 X'_1 X'_2 Y}) | \mathbf{x}_{1r}, \mathbf{x}_{2s}, \mathbf{x}_3). \quad (27)$$

Let

$$P_{r,s}^1(P_{X_1 X_2 X_3 X'_1 X'_2 Y}) := W^n(\mathcal{E}_{r,s,1}(P_{X_1 X_2 X_3 X'_1 X'_2 Y}) | \mathbf{x}_{1r}, \mathbf{x}_{2s}, \mathbf{x}_3).$$

Note that $P_{r,s}^1(P_{X_1 X_2 X_3 X'_1 X'_2 Y})$ is upper bounded by the probability of error when r and s are sent by user 1 and user 2 respectively. So, $P_{r,s}^1(P_{X_1 X_2 X_3 X'_1 X'_2 Y}) \leq 1$. Thus, from (27), we see that it is sufficient to show that $P_{r,s}^1(P_{X_1 X_2 X_3 X'_1 X'_2 Y})$ falls exponentially. From (15), note that when $P_{X_1 X_2 X_3 X'_1 X'_2 Y} \in \mathcal{Q}_1$ satisfies

$$I(X_1; X_2 X'_1 X'_2 X_3) + I(X_2; X'_1 X'_2 X_3) \geq \left| |R_1 - I(X'_1; X_3)|^+ + |R_2 - I(X'_2; X_3)|^+ - I(X'_1; X'_2 | X_3) \right|^+ + \epsilon,$$

$$\frac{1}{N_1 N_2} \sum_{r,s} P_{r,s}^1(P_{X_1 X_2 X_3 X'_1 X'_2 Y}) \quad (28)$$

$$= \frac{1}{N_1 N_2} \sum_{\substack{(r,s): \exists (u,v) \text{ satisfying} \\ (\mathbf{x}_{1r}, \mathbf{x}_{2s}, \mathbf{x}_3, \mathbf{x}_{1u}, \mathbf{x}_{2v}) \in T_{X_1 X_2 X_3 X'_1 X'_2}^n}} W^n \left(\left\{ \mathbf{y} : \mathbf{y} \in T_{Y | X_1 X_2 X_3 X'_1 X'_2}^n(\mathbf{x}_{1r}, \mathbf{x}_{2s}, \mathbf{x}_3, \mathbf{x}_{1u}, \mathbf{x}_{2v}) \right\} \middle| \mathbf{x}_{1r}, \mathbf{x}_{2s}, \mathbf{x}_3 \right) \quad (29)$$

$$\leq \frac{1}{N_1 N_2} |\{(r, s) \in [1 : N_1] \times [1 : N_2] : \exists u, v \in [1 : N_1] \times [1 : N_2] u \neq r, v \neq r, (\mathbf{x}_{1r}, \mathbf{x}_{2s}, \mathbf{x}_{1u}, \mathbf{x}_{2v}, \mathbf{x}_3) \in T_{X_1 X_2 X_3 X'_1 X'_2 X_3}^n\}| \\ < \exp\left(-\frac{n\epsilon}{2}\right). \quad (30)$$

Otherwise, when

$$I(X_1; X_2 X'_1 X'_2 X_3) + I(X_2; X'_1 X'_2 X_3) < \left| |R_1 - I(X'_1; X_3)|^+ + |R_2 - I(X'_2; X_3)|^+ - I(X'_1; X'_2 | X_3) \right|^+ + \epsilon, \quad (31)$$

we will show that $P_{r,s}^1(P_{X_1 X_2 X_3 X'_1 X'_2 Y}) \rightarrow 0$ exponentially for each $P_{X_1 X_2 X_3 X'_1 X'_2 Y} \in \mathcal{Q}_1$. We will show this by using the following upper bound.

$$\begin{aligned} P_{r,s}^1(P_{X_1 X_2 X_3 X'_1 X'_2 Y}) &= W^n(\mathcal{E}_{r,s,1}(P_{X_1 X_2 X_3 X'_1 X'_2 Y}) | \mathbf{x}_{1r}, \mathbf{x}_{2s}, \mathbf{x}_3) \\ &\leq \sum_{\substack{(u,v): (\mathbf{x}_{1r}, \mathbf{x}_{2s}, \mathbf{x}_3, \mathbf{x}_{1u}, \mathbf{x}_{2v}) \\ \in T_{X_1 X_2 X_3 X'_1 X'_2}^n}} \sum_{\mathbf{y} \in T_{Y | X_1 X_2 X_3 X'_1 X'_2}^n(\mathbf{x}_{1r}, \mathbf{x}_{2s}, \mathbf{x}_3, \mathbf{x}_{1u}, \mathbf{x}_{2v})} W^n(\mathbf{y} | \mathbf{x}_{1r}, \mathbf{x}_{2s}, \mathbf{x}_3) \\ &\leq \sum_{\substack{(u,v): (\mathbf{x}_{1r}, \mathbf{x}_{2s}, \mathbf{x}_3, \mathbf{x}_{1u}, \mathbf{x}_{2v}) \\ \in T_{X_1 X_2 X_3 X'_1 X'_2}^n}} \exp(-n(I(Y; X'_1 X'_2 | X_1 X_2 X_3) - \epsilon)) \\ &\stackrel{(a)}{\leq} \exp\left(n \left(\left| |R_1 - I(X'_1; X_1 X_2 X_3)|^+ + |R_2 - I(X'_2; X_1 X_2 X_3)|^+ - I(X'_1; X'_2 | X_1 X_2 X_3) \right|^+ - I(Y; X'_1 X'_2 | X_1 X_2 X_3) + 3\epsilon/2 \right)\right). \end{aligned} \quad (32)$$

where (a) follows from (12). Note that $\left| |R_1 - I(X'_1; X_3)|^+ + |R_2 - I(X'_2; X_3)|^+ - I(X'_1; X'_2 | X_3) \right|^+ = 0$ if at least one of the following three conditions hold.

$$R_1 \leq I(X'_1; X_3) \text{ and } R_2 \leq I(X'_2; X_1 X_3) \quad (33)$$

$$R_1 \leq I(X'_1; X'_2 X_3) \text{ and } R_2 \leq I(X'_2; X_3) \quad (34)$$

$$R_1 \leq I(X'_1; X_3), R_2 \leq I(X'_2; X'_1) \text{ and } R_1 + R_2 \leq I(X'_1; X_3) + I(X'_2; X_3) + I(X'_1; X'_2 | X_3) \quad (35)$$

Thus, (31) implies that $I(X_1; X_2 X'_1 X'_2 X_3) + I(X_2; X'_1 X'_2 X_3) < \epsilon$. This further implies the following:

$$\begin{aligned} \epsilon &> I(X_1; X_2 X'_1 X'_2 X_3) + I(X_2; X'_1 X'_2 X_3) \\ &\geq I(X_1; X'_1 X'_2 | X_2 X_3) + I(X_2; X'_1 X'_2 | X_3) \\ &= I(X_1 X_2; X'_1 X'_2 | X_3). \end{aligned}$$

One can also verify that when (33), (34) or (35) holds, (32) evaluates to $\exp(n(0 - I(Y; X'_1 X'_2 | X_1 X_2 X_3) + 3\epsilon/2))$. Thus,

$$\begin{aligned} P_{r,s}^1(P_{X_1 X_2 X_3 X'_1 X'_2 Y}) &\leq \exp(n(-I(Y; X'_1 X'_2 | X_1 X_2 X_3) + 3\epsilon/2)) \\ &\leq \exp(n(I(X_1 X_2; X'_1 X'_2 | X_3) - I(X_1 X_2 Y; X'_1 X'_2 | X_3) + 3\epsilon/2)) \\ &\stackrel{(a)}{\leq} \exp(n(\epsilon - \eta + 3\epsilon/2)) \\ &= \exp(n(5\epsilon/2 - \eta)) \\ &\rightarrow 0 \text{ if } \eta > 5\epsilon/2. \end{aligned}$$

where (a) uses the fact that $I(X_1 X_2; X'_1 X'_2 | X_3) < \epsilon$ and $I(X_1 X_2 Y; X'_1 X'_2 | X_3) \geq \eta$.

Now, consider the case when $\left| |R_1 - I(X'_1; X_3)|^+ + |R_2 - I(X'_2; X_3)|^+ - I(X'_1; X'_2 | X_3) \right|^+ = R_1 - I(X'_1; X'_2 X_3)$. This will happen when $R_1 \geq I(X'_1; X'_2 X_3)$ and $R_2 \leq I(X'_2; X_3)$. In this case (31) evaluates to $I(X_1; X_2 X'_1 X'_2 X_3) + I(X_2; X'_1 X'_2 X_3) < R_1 - I(X'_1; X'_2 X_3) + \epsilon$. This implies the following:

$$\begin{aligned} \epsilon &> I(X_1; X_2 X'_1 X'_2 X_3) + I(X_2; X'_1 X'_2 X_3) + I(X'_1; X'_2 X_3) - R_1 \\ &\geq I(X_1; X'_1 | X'_2 X_2 X_3) + I(X_2; X'_1 | X'_2 X_3) + I(X'_1; X'_2 X_3) - R_1 \\ &= I(X'_1; X_1 X_2 X_3 X'_2) - R_1. \end{aligned}$$

Thus,

$$R_1 - I(X'_1; X_1 X_2 X_3 X'_2) \geq -\epsilon.$$

This implies that

$$|R_1 - I(X'_1; X_1 X_2 X_3)|^+ \leq R_1 - I(X'_1; X_1 X_2 X_3) + \epsilon$$

and we get the following upper bound on (32):

$$\begin{aligned} &\exp\left(n\left(\left| |R_1 - I(X'_1; X_1 X_2 X_3)|^+ + |R_2 - I(X'_2; X_1 X_2 X_3)|^+ - I(X'_1; X'_2 | X_1 X_2 X_3) \right|^+ - I(Y; X'_1 X'_2 | X_1 X_2 X_3) + 3\epsilon/2 \right)\right) \\ &\leq \exp(n(R_1 - I(X'_1; X_1 X_2 X_3 X'_2) + \epsilon + 0 - I(Y; X'_1 X'_2 | X_1 X_2 X_3) + 3\epsilon/2)) \quad (36) \\ &\leq \exp(n(R_1 - I(X'_1; X_1 X_2 X_3 X'_2 Y) + 5\epsilon/2)) \\ &\leq \exp(n(R_1 - I(X'_1; X'_2 Y) + 5\epsilon/2)) \\ &\leq \exp\left(n\left(R_1 - I(\tilde{X}_1; \tilde{Y} | \tilde{X}_2) + \gamma + 5\epsilon/2\right)\right) \end{aligned}$$

where $P_{\tilde{X}_1 \tilde{X}_2 \tilde{X}_3 \tilde{Y}} \stackrel{\text{def}}{=} P_{X'_1} \times P_{X_2} \times P_{X'_3} \times W$ and γ is chosen to satisfy $I(X'_1; X'_2 Y) \geq I(\tilde{X}_1; \tilde{Y} | \tilde{X}_2) - \gamma$. Note that $P_{X'_1 X'_2 X'_3 Y}$ is such that $D(P_{X'_1 X'_2 X'_3 Y} || P_{X'_1} \times P_{X_2} \times P_{X'_3} \times W) < \eta$ where η can be chosen arbitrarily small. Thus, $P_{X'_1 X'_2 X'_3 Y}$ is arbitrarily close to $P_{\tilde{X}_1 \tilde{X}_2 \tilde{X}_3 \tilde{Y}}$ and γ can be chosen arbitrarily small. Thus, $P_{r,s}^1(P_{X_1 X_2 X_3 X'_1 X'_2 Y}) \rightarrow 0$ exponentially, if

$$R_1 < I(\tilde{X}_1; \tilde{Y} | \tilde{X}_2) - \gamma - 5\epsilon/2.$$

Minimizing this in the limit of $n \rightarrow \infty$ and $\epsilon, \eta \rightarrow 0$ over all $P_{X_1 X_2 X_3 X'_1 X'_2 Y} \in \mathcal{Q}_1$ is same as minimizing $I(\tilde{X}_1; \tilde{Y} | \tilde{X}_2)$ over $P_{\tilde{X}_1 \tilde{X}_2 \tilde{X}_3 \tilde{Y}} \in \mathcal{P}_3$ where \mathcal{P}_3 is defined as

$$\mathcal{P}_3 \stackrel{\text{def}}{=} \{P_{X_1 X_2 X_3 Y} : P_{X_1 X_2 X_3 Y} = P_{X_1} \times P_{X_2} \times Q_{X_3} \times W \text{ for some } Q_{X_3}\}.$$

Using definition of \mathcal{P}_3 , we obtain the following bound on R_1

$$R_1 < \min_{P_{X_1 X_2 X_3 Y} \in \mathcal{P}_3} I(X_1; Y | X_2). \quad (37)$$

Now, suppose $\left| |R_1 - I(X'_1; X_3)|^+ + |R_2 - I(X'_2; X_3)|^+ - I(X'_1; X'_2 | X_3) \right|^+ = R_2 - I(X'_2; X'_1 X_3)$. This means that $R_1 \leq I(X'_1; X_3)$ and $R_2 \geq I(X'_2; X'_1 X_3)$. In this case (31) evaluates to $I(X_1; X_2 X'_1 X'_2 X_3) + I(X_2; X'_1 X'_2 X_3) < R_2 - I(X'_2; X'_1 X_3) + \epsilon$. Thus,

$$\begin{aligned} \epsilon &> I(X_1; X_2 X'_1 X'_2 X_3) + I(X_2; X'_1 X'_2 X_3) + I(X'_2; X'_1 X_3) - R_2 \\ &\geq I(X_1; X'_2 | X'_1 X_2 X_3) + I(X_2; X'_2 | X'_1 X_3) + I(X'_2; X'_1 X_3) - R_2 \\ &= I(X'_2; X_1 X_2 X_3 X'_1) - R_2. \end{aligned}$$

This implies that

$$R_2 - I(X'_2; X_1 X_2 X_3 X'_1) \geq -\epsilon.$$

Thus, $|R_2 - I(X'_2; X_1 X_2 X_3 X'_1)|^+ \leq R_2 - I(X'_2; X_1 X_2 X_3 X'_1) + \epsilon$. Substituting this in (32), we get the following upper bound:

$$\exp(n(0 + R_2 - I(X'_2; X_1 X_2 X_3 X'_1) + \epsilon - I(Y; X'_1 X'_2 | X_1 X_2 X_3) + 3\epsilon/2))$$

This is same as the upper bound in (36) with X'_1 and X'_2 interchanged, and R_1 replaced by R_2 . Thus, we can do a symmetric analysis as in the previous case to obtain the following bound on R_2 :

$$R_2 < \min_{P_{X_1 X_2 X_3 Y} \in \mathcal{P}_3} I(X_2; Y | X_1) \quad (38)$$

Suppose $\left| |R_1 - I(X'_1; X_3)|^+ + |R_2 - I(X'_2; X_3)|^+ - I(X'_1; X'_2 | X_3) \right|^+ = R_1 - I(X'_1; X_3) + R_2 - I(X'_2; X'_1 X_3)$. This happens when $R_1 \geq I(X'_1; X_3)$, $R_2 \geq I(X'_2; X_3)$ and $R_1 + R_2 \geq I(X'_1; X_3) + I(X'_2; X_3) + I(X'_1; X'_2 | X_3)$. In this case (31) evaluates to $I(X_1; X_2 X'_1 X'_2 X_3) + I(X_2; X'_1 X'_2 X_3) < R_1 + R_2 - I(X'_1; X_3) + I(X'_2; X'_1 X_3) + \epsilon$. Thus,

$$\begin{aligned} \epsilon &> I(X_1; X_2 X'_1 X'_2 X_3) + I(X_2; X'_1 X'_2 X_3) + I(X'_1; X_3) + I(X'_2; X'_1 X_3) - R_1 - R_2 \\ &\geq I(X_1; X'_1 | X_2 X_3) + I(X_1; X'_2 | X'_1 X_2 X_3) + I(X_2; X'_1 | X_3) + I(X_2; X'_2 | X'_1 X_3) + I(X'_1; X_3) + I(X'_2; X'_1 X_3) - R_1 - R_2 \\ &= I(X'_1; X_1 X_2 X_3) + I(X'_2; X_1 X_2 X_3 X'_1) - R_1 - R_2. \end{aligned}$$

This implies that

$$R_1 - I(X'_1; X_1 X_2 X_3) + R_2 - I(X'_2; X_1 X_2 X_3) - I(X'_1; X'_2 | X_1 X_2 X_3) \geq -\epsilon.$$

Note that

$$\begin{aligned} &\left| |R_1 - I(X'_1; X_1 X_2 X_3)|^+ + |R_2 - I(X'_2; X_1 X_2 X_3)|^+ - I(X'_1; X'_2 | X_1 X_2 X_3) \right|^+ \\ &\geq R_1 - I(X'_1; X_1 X_2 X_3) + R_2 - I(X'_2; X_1 X_2 X_3) - I(X'_1; X'_2 | X_1 X_2 X_3) \\ &\geq -\epsilon. \end{aligned}$$

So,

$$\begin{aligned} & \left| |R_1 - I(X'_1; X_1 X_2 X_3)|^+ + |R_2 - I(X'_2; X_1 X_2 X_3)|^+ - I(X'_1; X'_2 | X_1 X_2 X_3) \right|^+ \\ & \leq R_1 - I(X'_1; X_1 X_2 X_3) + R_2 - I(X'_2; X_1 X_2 X_3) - I(X'_1; X'_2 | X_1 X_2 X_3) + \epsilon. \end{aligned}$$

Thus,

$$\begin{aligned} P_{r,s}^1(P_{X_1 X_2 X_3 X'_1 X'_2 Y}) & \leq \exp(n(R_1 - I(X'_1; X_1 X_2 X_3) + R_2 - I(X'_2; X_1 X_2 X_3 X'_1) + \epsilon - I(Y; X'_1 X'_2 | X_1 X_2 X_3) + 3\epsilon/2)) \\ & \quad (39) \\ & = \exp(n(R_1 - I(X'_1; X_1 X_2 X_3) + R_2 - I(X'_2; X_1 X_2 X_3 X'_1) - I(Y; X'_1 X'_2 | X_1 X_2 X_3) + 5\epsilon/2)) \\ & \leq \exp(n(R_1 + R_2 - I(X'_1 X'_2; X_1 X_2 X_3) - I(Y; X'_1 X'_2 | X_1 X_2 X_3) + 5\epsilon/2)) \\ & \leq \exp(n(R_1 + R_2 - I(X'_1 X'_2; X_1 X_2 X_3 Y) + 5\epsilon/2)) \\ & \leq \exp(n(R_1 + R_2 - I(X'_1 X'_2; Y) + 5\epsilon/2)) \end{aligned}$$

Following similar steps as earlier, we obtain the following sum rate bound

$$R_1 + R_2 < \min_{P_{X_1 X_2 X_3 Y} \in \mathcal{P}_3} I(X_1 X_2; Y). \quad (40)$$

Now, we will look at the second term in (26), which is,

$$\sum_{P_{X_1 X_2 X_3 X'_1 Y} \in \mathcal{Q}_2} \frac{1}{N_1 N_2} \sum_{r,s} W^n(\mathcal{E}_{r,s,2}(P_{X_1 X_2 X_3 X'_1 Y}) | \mathbf{x}_{1r}, \mathbf{x}_{2s}, \mathbf{x}_3). \quad (41)$$

Let

$$P_{r,s}^2(P_{X_1 X_2 X_3 X'_1 Y}) := W^n(\mathcal{E}_{r,s,2}(P_{X_1 X_2 X_3 X'_1 Y}) | \mathbf{x}_{1r}, \mathbf{x}_{2s}, \mathbf{x}_3).$$

From (17), we see that when $P_{X_1 X_2 X_3 X'_1 Y}$ satisfies

$$I(X_i; X_j X'_i X_k) + I(X_j; X'_i X_k) \geq |R_i - I(X'_i; X_k)|^+ + \epsilon, \quad (42)$$

$$\begin{aligned} & \frac{1}{N_1 N_2} \sum_{r,s} P_{r,s}^2(P_{X_1 X_2 X_3 X'_1 Y}) \\ & = \frac{1}{N_1 N_2} \sum_{\substack{(r,s): \exists u \text{ satisfying} \\ (\mathbf{x}_{1r}, \mathbf{x}_{2s}, \mathbf{x}_3, \mathbf{x}_{1u}) \in T_{X_1 X_2 X_3 X'_1}^n}} W^n \left(\left\{ \mathbf{y} : \mathbf{y} \in T_{Y | X_1 X_2 X_3 X'_1}^n(\mathbf{x}_{1r}, \mathbf{x}_{2s}, \mathbf{x}_3, \mathbf{x}_{1u}) \right\} \middle| \mathbf{x}_{1r}, \mathbf{x}_{2s}, \mathbf{x}_3 \right) \end{aligned} \quad (43)$$

$$\begin{aligned} & \leq \frac{1}{N_1 N_2} |\{(r,s) \in [1:N_1] \times [1:N_2] : \exists u \in [1:N_1] u \neq r, (\mathbf{x}_{1r}, \mathbf{x}_{2s}, \mathbf{x}_3, \mathbf{x}_{1u}) \in T_{X_1 X_2 X_3 X'_1}^n\}| \\ & < \exp\left(-\frac{n\epsilon}{2}\right). \end{aligned} \quad (44)$$

Otherwise, when

$$I(X_i; X_j X'_i X_k) + I(X_j; X'_i X_k) < |R_i - I(X'_i; X_k)|^+ + \epsilon, \quad (45)$$

we will show that $P_{r,s}^2(P_{X_1 X_2 X_3 X'_1 Y})$ falls doubly exponentially for each $P_{X_1 X_2 X_3 X'_1 Y} \in \mathcal{Q}_2$. We will show this by using the following upper bound.

$$P_{r,s}^2(P_{X_1 X_2 X_3 X'_1 Y}) = W^n(\mathcal{E}_{r,s,2}(P_{X_1 X_2 X_3 X'_1 Y}) | \mathbf{x}_{1r}, \mathbf{x}_{2s}, \mathbf{x}_3)$$

$$\begin{aligned}
&\leq \sum_{\substack{u: (\mathbf{x}_{1r}, \mathbf{x}_{2s}, \mathbf{x}_3, \mathbf{x}_{1u}) \\ \in T_{X_1 X_2 X_3 X'_1}^n}} \sum_{\mathbf{y} \in T_{Y|X_1 X_2 X_3 X'_1}^n(\mathbf{x}_{1r}, \mathbf{x}_{2s}, \mathbf{x}_3, \mathbf{x}_{1u})} W^n(\mathbf{y}|\mathbf{x}_{1r}, \mathbf{x}_{2s}, \mathbf{x}_3) \\
&\leq \sum_{\substack{u: (\mathbf{x}_{1r}, \mathbf{x}_{2s}, \mathbf{x}_3, \mathbf{x}_{1u}) \\ \in T_{X_1 X_2 X_3 X'_1}^n}} \exp(-n(I(Y; X'_1|X_1 X_2 X_3) - \epsilon)) \\
&\stackrel{(a)}{=} \exp\left(n\left(|R_1 - I(X'_1; X_1 X_2 X_3)|^+ - I(Y; X'_1|X_1 X_2 X_3) + 3\epsilon/2\right)\right) \tag{46}
\end{aligned}$$

where (a) follows from (11).

Suppose $R_1 \leq I(X'_1; X_2)$, then (45) evaluates to $I(X_1; X_2 X'_1 X_3) + I(X_2; X'_1 X_3) < \epsilon$. Thus, $I(X_1 X_2; X'_1 X_3) < \epsilon$. We analyze (46) for this case.

$$\begin{aligned}
P_{r,s}^2(P_{X_1 X_2 X_3 X'_1 Y}) &\leq \exp\left(n\left(|R_1 - I(X'_1; X_1 X_2 X_3)|^+ - I(Y; X'_1|X_1 X_2 X_3) + 3\epsilon/2\right)\right) \\
&= \exp(n(0 - I(Y; X'_1|X_1 X_2 X_3) + 3\epsilon/2)) \\
&= \exp(n(I(X_1 X_2; X'_1|X_3) - I(X_1 X_2; X'_1|X_3) - I(Y; X'_1|X_1 X_2 X_3) + 3\epsilon/2)) \\
&= \exp(n(I(X_1 X_2; X'_1|X_3) - I(X_1 X_2 Y; X'_1|X_3) + 3\epsilon/2)) \\
&\stackrel{(a)}{\leq} \exp(n(\epsilon - \eta + 3\epsilon/2)) \\
&\rightarrow 0 \text{ if } \eta > 6\epsilon.
\end{aligned}$$

where (a) follows by using $I(X_1 X_2; X'_1|X_3) < \epsilon$ and $I(X_1 X_2 Y; X'_1|X_3) \geq \eta$ (see the definition of \mathcal{Q}_2).

Now, we consider the case when $R_1 > I(X'_1; X_2)$. In this case, (45) evaluates to

$$I(X_1; X_2 X'_1 X_3) + I(X_2; X'_1 X_3) < R_1 - I(X'_1; X_3) + \epsilon$$

This implies that $-\epsilon < R_1 - I(X'_1; X_1 X_2 X_3) \leq |R_1 - I(X'_1; X_1 X_2 X_3)|^+$. Thus,

$$|R_1 - I(X'_1; X_1 X_2 X_3)|^+ - I(Y; X'_1|X_1 X_2 X_3) \leq R_1 - I(X'_1; X_1 X_2 X_3) - I(Y; X'_1|X_1 X_2 X_3) + \epsilon$$

Plugging it into the upper bound on $P_{r,s}^2(P_{X_1 X_2 X_3 X'_1 Y})$, we obtain

$$\begin{aligned}
P_{r,s}^2(P_{X_1 X_2 X_3 X'_1 Y}) &\leq \exp(n(R_1 - I(X'_1; X_1 X_2 X_3) - I(Y; X'_1|X_1 X_2 X_3) + 5\epsilon/2)) \\
&= \exp(n(R_1 - I(X'_1; X_1 X_2 X_3 Y) + 5\epsilon/2)) \\
&= \exp(n(R_1 - I(X'_1; X_2 Y) + 5\epsilon/2))
\end{aligned}$$

Since $P_{X'_1 X_2 X'_3 Y}$ is such that $D(P_{X'_1 X_2 X'_3 Y} \| P_{X'_1} \times P_{X_2} \times P_{X'_3} \times W) < \eta$ where η can be chosen arbitrarily small, $P_{X'_1 X_2 X'_3 Y}$ is arbitrarily close to $P_{\tilde{X}_1 \tilde{X}_2 \tilde{X}_3 \tilde{Y}} \stackrel{\text{def}}{=} P_{X'_1} \times P_{X_2} \times P_{X'_3} \times W$. So, for small positive number γ_2 , $I(X'_1; X_2 Y) \geq I(\tilde{X}_1; \tilde{Y}|\tilde{X}_2) - \gamma_2 \geq \min_{P_{X'_3}} I(\tilde{X}_1; \tilde{Y}|\tilde{X}_2) - \gamma_2$. Thus, if

$$R_1 < \min_{P_{\tilde{X}_3}} I(\tilde{X}_1; \tilde{Y}|\tilde{X}_2) - 5\epsilon/2 - \gamma_2,$$

$$\text{then, } R_1 \leq \min_{P_{X'_3}} I(X'_1; Y|X_2) - 5\epsilon/2,$$

and therefore, $P_{e, x_1, x'_1, x_2, x_3 Y} \rightarrow 0$ as $n \rightarrow \infty$. In the limit of $\epsilon \rightarrow 0$, we get

$$R_1 \leq \min_{\substack{P_{X'_3}: P_{\tilde{X}_1 \tilde{X}_2 \tilde{X}_3 \tilde{Y}} \\ = P_{X'_1} \times P_{X_2} \times P_{X'_3} \times W}} I(\tilde{X}_1; \tilde{Y}|\tilde{X}_2) \tag{47}$$

This is same as the upper bound on R_1 given in (37).

We are left with the analysis of third term in (26), which is given by

$$\sum_{P_{X_1 X_2 X_3 X'_1 X'_3 Y} \in \mathcal{Q}_3} \frac{1}{N_1 N_2} \sum_{r,s} W^n(\mathcal{E}_{r,s,3}(P_{X_1 X_2 X_3 X'_1 X'_3 Y}) | \mathbf{x}_{1r}, \mathbf{x}_{2s}, \mathbf{x}_3). \quad (48)$$

Let

$$P_{r,s}^3(P_{X_1 X_2 X_3 X'_1 X'_3 Y}) := W^n(\mathcal{E}_{r,s,3}(P_{X_1 X_2 X_3 X'_1 X'_3 Y}) | \mathbf{x}_{1r}, \mathbf{x}_{2s}, \mathbf{x}_3).$$

When $P_{X_1 X_2 X_3 X'_1 X'_3 Y}$ satisfies the condition (see (16)),

$$I(X_i; X_j X'_i X'_k X_k) + I(X_j; X'_i X'_k X_k) \geq \left| |R_i - I(X'_i; X_k)|^+ + |R_k - I(X'_k; X_k)|^+ - I(X'_i; X'_k | X_k) \right|^+ + \epsilon,$$

$$\frac{1}{N_1 N_2} \sum_{r,s} P_{r,s}^3(P_{X_1 X_2 X_3 X'_1 X'_3 Y}) \quad (49)$$

$$= \frac{1}{N_1 N_2} \sum_{\substack{(r,s): \exists (u,w) \text{ satisfying} \\ (\mathbf{x}_{1r}, \mathbf{x}_{2s}, \mathbf{x}_3, \mathbf{x}_{1u}, \mathbf{x}_{3w}) \in T_{X_1 X_2 X_3 X'_1 X'_3}^n}} W^n \left(\left\{ \mathbf{y} : \mathbf{y} \in T_{Y | X_1 X_2 X_3 X'_1 X'_3}^n(\mathbf{x}_{1r}, \mathbf{x}_{2s}, \mathbf{x}_3, \mathbf{x}_{1u}, \mathbf{x}_{3w}) \right\} \middle| \mathbf{x}_{1r}, \mathbf{x}_{2s}, \mathbf{x}_3 \right) \quad (50)$$

$$\leq \frac{1}{N_1 N_2} \left| \{(r,s) \in [1 : N_1] \times [1 : N_2] : \exists u, w \in [1 : N_1] \times [1 : N_3] u \neq r (\mathbf{x}_{1r}, \mathbf{x}_{2s}, \mathbf{x}_3, \mathbf{x}_{1u}, \mathbf{x}_{3w}) \in T_{X_1 X_2 X_3 X'_1 X'_3}^n\} \right| < \exp\left(-\frac{n\epsilon}{2}\right). \quad (51)$$

Otherwise, when

$$I(X_i; X_j X'_i X'_k X_k) + I(X_j; X'_i X'_k X_k) < \left| |R_i - I(X'_i; X_k)|^+ + |R_k - I(X'_k; X_k)|^+ - I(X'_i; X'_k | X_k) \right|^+ + \epsilon, \quad (52)$$

we will show that $P_{r,s}^3(P_{X_1 X_2 X_3 X'_1 X'_3 Y})$ falls doubly exponentially for each $P_{X_1 X_2 X_3 X'_1 X'_3 Y} \in \mathcal{Q}_3$. We upper bound $P_{r,s}^3(P_{X_1 X_2 X_3 X'_1 X'_3 Y})$ by the following set of equations.

$$\begin{aligned} P_{r,s}^3(P_{X_1 X_2 X_3 X'_1 X'_3 Y}) &= W^n(\mathcal{E}_{r,s,3}(P_{X_1 X_2 X_3 X'_1 X'_3 Y}) | \mathbf{x}_{1r}, \mathbf{x}_{2s}, \mathbf{x}_3) \\ &\leq \sum_{\substack{(u,w): (\mathbf{x}_{1r}, \mathbf{x}_{2s}, \mathbf{x}_3, \mathbf{x}_{1u}, \mathbf{x}_{3w}) \\ \in T_{X_1 X_2 X_3 X'_1 X'_3}^n}} \sum_{\mathbf{y} \in T_{Y | X_1 X_2 X_3 X'_1 X'_3}^n(\mathbf{x}_{1r}, \mathbf{x}_{2s}, \mathbf{x}_3, \mathbf{x}_{1u}, \mathbf{x}_{3w})} W^n(\mathbf{y} | \mathbf{x}_{1r}, \mathbf{x}_{2s}, \mathbf{x}_3) \\ &\leq \sum_{\substack{(u,w): (\mathbf{x}_{1r}, \mathbf{x}_{2s}, \mathbf{x}_3, \mathbf{x}_{1u}, \mathbf{x}_{3w}) \\ \in T_{X_1 X_2 X_3 X'_1 X'_3}^n}} \exp(-n(I(Y; X'_1 X'_3 | X_1 X_2 X_3) - \epsilon)) \\ &\stackrel{(a)}{=} \exp\left(n \left(|R_1 - I(X'_1; X_1 X_2 X_3)|^+ + |R_3 - I(X'_3; X_1 X_2 X_3)|^+ - I(X'_1; X'_3 | X_1 X_2 X_3)|^+ - I(Y; X'_1 X'_3 | X_1 X_2 X_3) + 3\epsilon/2 \right)\right). \end{aligned} \quad (53)$$

where (a) follows from (13). Now, we need to show that (53) goes to zero under the condition given in (52). This is same as the previous analysis of (31) under the condition (32) with R_2 and X'_2 replaced by R_3 and X'_3 . Note that with these replacements, the entire analysis follows through and we obtain the analogues of (37), (38) and (40) as given in (54), (55) and (56) respectively. For

$$\mathcal{P}_2 \stackrel{\text{def}}{=} \{P_{X_1 X_2 X_3 Y} : P_{X_1 X_2 X_3 Y} = P_{X_1} \times Q_{X_2} \times P_{X_3} \times W \text{ for some } Q_{X_2}\}$$

$$R_1 < \min_{P_{X_1 X_2 X_3 Y} \in \mathcal{P}_2} I(X_1; Y | X_3); \quad (54)$$

$$R_3 < \min_{P_{X_1 X_2 X_3 Y} \in \mathcal{P}_2} I(X_3; Y | X_1); \quad (55)$$

$$R_1 + R_3 < \min_{P_{X_1 X_2 X_3 Y} \in \mathcal{P}_2} I(X_1 X_3; Y). \quad (56)$$

Similarly, we will obtain rate bounds while analyzing the cases when user 1 and 2 are adversarial. This will give us the entire rate region \mathcal{R} given by (8) and (9). \square

4.2 Randomized coding capacity region

Proof (Achievability of Theorem 3). For each $k = 1, 2, 3$, let $W^{(k)}$ be the 2-user AV-MAC formed by channel inputs from node k as the state and the remaining channel inputs as legitimate inputs. Let (R_1, R_2, R_3) be a rate triple such that, for some $p_1(x_1)p_2(x_2)p_3(x_3)$, the following conditions hold for all permutations (i, j, k) of $(1, 2, 3)$:

$$R_i < \min_{q(x_k)} I(X_i; Y | X_j), \quad \text{and} \quad (57)$$

$$R_i + R_j < \min_{q(x_k)} I(X_i, X_j; Y), \quad (58)$$

with the mutual information terms evaluated using the joint distribution $p_i(x_i)p_j(x_j)q(x_k)W_{Y|X_1 X_2 X_3}(y|x_1, x_2, x_3)$. Note that, by the first part of the direct result of [8, Theorem 1] (see [8, Section III-C]), the rate pair (R_i, R_j) is an achievable rate pair for the AV-MAC $W^{(k)}$. Let $\epsilon > 0$. For each $i \in \{1, 2, 3\}$, let $\tilde{\mathcal{M}}_i = [1 : 2^{nR_i}]$ and $\mathcal{M}_i = [1 : 2^{nR_i}/v]$ for the largest integer $v \leq 3/\epsilon$. In the following, we show the existence of a randomized $(2^{nR_1}/v, 2^{nR_2}/v, 2^{nR_3}/v, n)$ code (F_1, F_2, F_3, ϕ) with P_e^{strong} no larger than ϵ , for sufficiently large n .

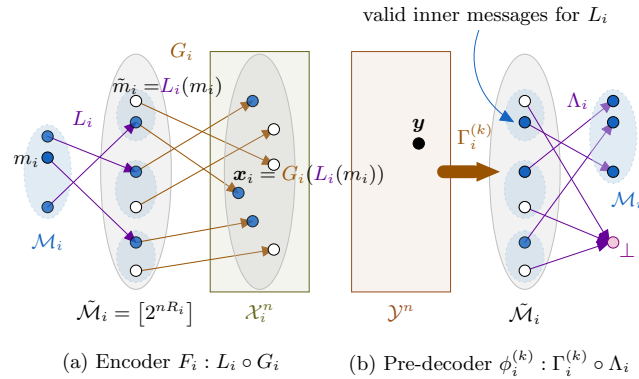

Figure 12: The encoders and pre-decoders for Theorem 3.

Code design. We will first describe some randomized maps which will be used in the code design (see Figure 12). For each $i \in \{1, 2, 3\}$, let $G_i : \tilde{\mathcal{M}}_i \rightarrow \mathcal{X}_i^n$ be a randomized map such that it maps $m_i \in \tilde{\mathcal{M}}_i$ to an n -length i.i.d. sequence $G_i(m_i)$ generated according to the distribution p_i . The sequences $G_i(m)$ are independent across $i \in \{1, 2, 3\}$ and $m \in \tilde{\mathcal{M}}_i$. The realization of $G_i(m_i)$ for all $i \in \{1, 2, 3\}$ and $m_i \in \tilde{\mathcal{M}}_i$ is shared with the decoder. For any permutation (i, j, k) of $(1, 2, 3)$, consider the AV-MAC $W^{(k)}$ which corresponds to user- k as the adversary. If we consider $\tilde{\mathcal{M}}_i$ and $\tilde{\mathcal{M}}_j$ as the message sets and G_i and G_j as the corresponding encoders, then this construction ensures that the randomness of the encoders G_i and G_j is private from each other and also private from the adversarial

user- k . This joint distribution of G_i and G_j (and the corresponding codewords) is the same as that of the encoders of AV-MAC $W^{(k)}$ in the direct part of [8, Theorem 1, Section III-C]. For G_i and G_j as encoders, let $\Gamma^{(k)}$ denote the decoder corresponding to the decoding sets defined in proof of the direct part of [8, Theorem 1, Section III-C] for the AV-MAC $W^{(k)}$. Suppose $(\Gamma_i^{(k)}, \Gamma_j^{(k)}) := \Gamma^{(k)}$ where $\Gamma_i^{(k)} : \mathcal{Y}^n \rightarrow \tilde{\mathcal{M}}_i$. For all $\epsilon > 0$, by [8, Theorem 1], there exists a large enough n such that for all permutations (i, j, k) of $(1, 2, 3)$, the code $(G_i, G_j, \Gamma^{(k)})$ has error probability no larger than $\epsilon/3$. We consider that n .

For each $i \in \{1, 2, 3\}$, the message set \mathcal{M}_i is randomly embedded into the set $\tilde{\mathcal{M}}_i$ as follows: We choose an arbitrary partition of \mathcal{M}_i into $|\mathcal{M}_i|$ many disjoint equal-sized subsets (each subset size is v). Let us denote the partition by \mathcal{S}_{m_i} , $m_i \in \mathcal{M}_i$ where $\cup_{m_i \in \mathcal{M}_i} \mathcal{S}_{m_i} = \tilde{\mathcal{M}}_i$ and $\mathcal{S}_{m_i} \cap \mathcal{S}_{m'_i} = \emptyset$ for all $m_i, m'_i \in \mathcal{M}_i$ where $m_i \neq m'_i$. The size of each \mathcal{S}_{m_i} , $m_i \in \mathcal{M}_i$ is v ($\leq 3/\epsilon$). The maps $L_i : \mathcal{M}_i \rightarrow \tilde{\mathcal{M}}_i$ and $\Lambda_i : \tilde{\mathcal{M}}_i \rightarrow \mathcal{M}_i$ are the forward and reverse maps for an injection from \mathcal{M}_i to $\tilde{\mathcal{M}}_i$ where, independently for each $m_i \in \mathcal{M}_i$, $L_i(m_i)$ is chosen uniformly at random from \mathcal{S}_{m_i} . Both the encoder maps G_i and L_i are independent for $i = 1, 2, 3$ and are made available to the decoder as the shared secret between user- i and the decoder, unknown to other users.

For each $i \in \{1, 2, 3\}$, the encoder map $F_i : \mathcal{M}_i \rightarrow \mathcal{X}_i^n$ is defined as $F_i(m_i) = G_i(L_i(m_i))$ for every $m_i \in \mathcal{M}_i$. For $i \in \{1, 2, 3\}$ and $k \in \{1, 2, 3\} \setminus \{i\}$, we define pre-decoder¹⁰

$$\phi_i^{(k)}(\mathbf{y}) := \begin{cases} \Lambda_i(\Gamma_i^{(k)}(\mathbf{y})) & \text{if } \Gamma_i^{(k)}(\mathbf{y}) \in L_i(\mathcal{M}_i), \\ \perp & \text{otherwise.} \end{cases}$$

The decoder $\phi : \mathcal{Y}^n \rightarrow \mathcal{M}_1 \times \mathcal{M}_2 \times \mathcal{M}_3$ outputs $\phi(\mathbf{y}) = (\hat{m}_1, \hat{m}_2, \hat{m}_3)$, where, for each $i \in \{1, 2, 3\}$ and (j, k) a permutation of $\{1, 2, 3\} \setminus \{i\}$,

$$\hat{m}_i = \begin{cases} \phi_i^{(j)}(\mathbf{y}) & \text{if } \phi_i^{(j)}(\mathbf{y}) = \phi_i^{(k)}(\mathbf{y}) \neq \perp \\ \phi_i^{(j)}(\mathbf{y}) & \text{if } \phi_i^{(j)}(\mathbf{y}) \neq \perp \text{ and } \phi_i^{(k)}(\mathbf{y}) = \perp \\ \phi_i^{(k)}(\mathbf{y}) & \text{if } \phi_i^{(k)}(\mathbf{y}) \neq \perp \text{ and } \phi_i^{(j)}(\mathbf{y}) = \perp \\ 1 & \text{otherwise.} \end{cases}$$

Error Analysis. We first show that as long as the rate triple (R_1, R_2, R_3) satisfy the constraints (57) and (58), i.e., each pair of rates lie in the corresponding AV-MAC randomized coding capacity region, the following hold simultaneously for every honest user i which sends message $m_i \in \mathcal{M}_i$ and potentially adversarial user $k \neq i$: (i) $\phi_i^{(k)}(\mathbf{Y})$ is m_i w.h.p. (with probability at least $1 - \epsilon/3$) if user- k is indeed adversarial and (ii) $\phi_i^{(k)}(\mathbf{Y})$ is, w.h.p. (with probability at least $1 - \epsilon/3$), either \perp or m_i if user- k is not adversarial. To this end, consider any permutation (i, j, k) of $(1, 2, 3)$ and assume that the adversarial user (if any) is user- k which sends \mathbf{X}_k as its potentially adversarial input to the channel. Suppose, for $(m_i, m_j) \in \mathcal{M}_i \times \mathcal{M}_j$, user- i and user- j send $F_i(m_i)$ and $F_j(m_j)$ respectively. Let \mathbf{Y} denote the channel output.

(i) First, consider the AV-MAC $W^{(k)}$. Recall that $\Gamma_i^{(k)}(\mathbf{Y}) = L_i(m_i)$ with probability at least $1 - \epsilon/3$. Thus, with probability at least $1 - \epsilon/3$, $\phi_i^{(k)}(\mathbf{Y})$ equals m_i .

(ii) Next, consider the AV-MAC $W^{(j)}$. In this case, $\Gamma_i^{(j)}(\mathbf{Y})$ may not equal $L_i(m_i)$ as \mathbf{X}_k may not be a valid codeword. We would like to compute $\mathbb{P}(\phi_i^{(j)}(\mathbf{Y}) \notin \{m_i, \perp\})$ where the probability is over $G_i(L_i(m_i))$, $G_j(L_j(m_j))$, \mathbf{X}_k and the channel. Note that G_i and L_i are independent of (potentially jointly distributed and adversarially chosen) G_k , L_k and \mathbf{X}_k . Thus,

$$\mathbb{P}(\phi_i^{(j)}(\mathbf{Y}) \notin \{m_i, \perp\})$$

¹⁰In this notation $\phi_i^{(k)}(\mathbf{y})$, we are suppressing the dependence of the pre-decoder (and later the decoder) on the randomness of the encoders.

$$\begin{aligned}
&= \mathbb{P}\left(\Gamma_i^{(j)}(\mathbf{Y}) \in L_i(\mathcal{M}_i \setminus \{m_i\})\right) \\
&= \sum_{\tilde{m}_i \in \tilde{\mathcal{M}} \setminus \mathcal{S}_{m_i}} \mathbb{P}\left(\Gamma_i^{(j)}(\mathbf{Y}) = \tilde{m}_i, \tilde{m}_i \in L_i(\mathcal{M}_i \setminus \{m_i\})\right) \\
&= \sum_{\tilde{m}_i \in \tilde{\mathcal{M}} \setminus \mathcal{S}_{m_i}} \mathbb{P}\left(\Gamma_i^{(j)}(\mathbf{Y}) = \tilde{m}_i\right) \mathbb{P}\left(\tilde{m}_i \in L_i(\mathcal{M}_i \setminus \{m_i\}) \mid \Gamma_i^{(j)}(\mathbf{Y}) = \tilde{m}_i\right) \\
&\stackrel{(a)}{=} \sum_{\tilde{m}_i \in \tilde{\mathcal{M}} \setminus \mathcal{S}_{m_i}} \mathbb{P}\left(\Gamma_i^{(j)}(\mathbf{Y}) = \tilde{m}_i\right) \mathbb{P}\left(\tilde{m}_i \in L_i(\mathcal{M}_i \setminus \{m_i\})\right) \\
&\stackrel{(b)}{=} \sum_{\tilde{m}_i \in \tilde{\mathcal{M}} \setminus \mathcal{S}_{m_i}} \mathbb{P}\left(\Gamma_i^{(j)}(\mathbf{Y}) = \tilde{m}_i\right) \cdot \frac{1}{v} \\
&\leq 1/v \leq \epsilon/3.
\end{aligned}$$

Here, (a) holds as $\Gamma_i^{(j)}(\mathbf{Y}) \perp\!\!\!\perp L_i(\mathcal{M}_i \setminus \{m_i\})$. This is because $L_i(m_i) \perp\!\!\!\perp L_i(\mathcal{M}_i \setminus \{m_i\})$ and $\Gamma_i^{(j)} \perp\!\!\!\perp L_i$ as $\Gamma_i^{(j)}$ is a function of AV-MAC encoders G_i and G_k which are independent of L_i . The equality (b) holds because for $\tilde{m}_i \in \tilde{\mathcal{M}} \setminus \mathcal{S}_{m_i}$,

$$\begin{aligned}
&\mathbb{P}(\tilde{m}_i \in L_i(\mathcal{M}_i \setminus \{m_i\})) \\
&= \sum_{m'_i \in \mathcal{M}_i \setminus \{m_i\}} \mathbb{P}(L_i(m'_i) = \tilde{m}_i) \\
&= \sum_{m'_i \in \mathcal{M}_i \setminus \{m_i\}} \mathbb{1}_{\{\tilde{m}_i \in \mathcal{S}_{m'_i}\}} \cdot \frac{1}{v} \\
&= 1/v.
\end{aligned}$$

Thus, with probability $1 - \epsilon$, for each non-adversarial user i , at least one of the decoders $\phi_i^{(j)}$ or $\phi_i^{(k)}$ outputs the true message while the other decoder outputs either the true message or \perp .

□

Proof (Converse of Theorem 3). We show converse for the weak adversary. Suppose (F_1, F_2, F_3, ϕ) is a $(2^{nR_1}, 2^{nR_2}, 2^{nR_3}, n)$ randomized code such that $P_e \leq \epsilon$ for some $\epsilon > 0$. Recall that F_1, F_2, F_3 are independent. Let $M_i \sim \text{Unif}(\mathcal{M}_i)$, $i = 1, 2, 3$ be independent. Let $\hat{M}_i = \phi_i(\mathbf{Y}, F_1, F_2, F_3)$, $i = 1, 2, 3$. Then, ϵ is an upper bound on (4) which is given by

$$\begin{aligned}
P_{e,1}^{\text{weak}} &= \max_{\mathbf{x}_1} \mathbb{P}_{F_2, F_3} \left((\hat{M}_2, \hat{M}_3) \neq (M_2, M_3) \mid \mathbf{X}_1 = \mathbf{x}_1, \mathbf{X}_2 = F_2(M_2), \mathbf{X}_3 = F_3(M_3) \right) \\
&= \max_{p_{\mathbf{X}_1}} \mathbb{P}_{F_2, F_3} \left((\hat{M}_2, \hat{M}_3) \neq (M_2, M_3) \mid \mathbf{X}_2 = F_2(M_2), \mathbf{X}_3 = F_3(M_3) \right).
\end{aligned}$$

For a vector $\mathbf{x}_j \in \mathcal{X}_j^n$, $j = 1, 2, 3$, we use $x_{j,i}$ to denote its i^{th} index. That is $\mathbf{x}_j = (x_{j,1}, x_{j,2}, \dots, x_{j,n})$. Similarly, a random vector \mathbf{X}_j distributed on \mathcal{X}_j^n can be written as $\mathbf{X}_j = (X_{j,1}, X_{j,2}, \dots, X_{j,n})$. For $i \in [1 : n]$, let $q_{X_{1,i}}$ be some distribution on \mathcal{X}_1 . We consider the following $p_{\mathbf{X}_1}$.

$$p_{\mathbf{X}_1}(\mathbf{x}_1) = \prod_{i=1}^n q_{X_{1,i}}(x_{1,i}).$$

By Fano's inequality, under this $p_{\mathbf{X}_1}$ and when $\mathbf{X}_i = F_i(M_i)$, $i = 2, 3$,

$$H(M_2, M_3 \mid \mathbf{Y}, F_2, F_3) \leq 1 + n\epsilon(R_2 + R_3).$$

Ignoring small terms, we have

$$\begin{aligned}
n(R_2 + R_3) &\leq H(M_2, M_3) \\
&\leq H(M_2, M_3 | F_2, F_3) \\
&\stackrel{(a)}{\approx} I(M_2, M_3; \mathbf{Y} | F_2, F_3) \\
&= \sum_{i=1}^n I(M_2, M_3; Y_i | Y^{i-1}, F_2, F_3) \\
&\leq \sum_{i=1}^n I(M_2, M_3, F_2, F_3, Y^{i-1}; Y_i) \\
&= \sum_{i=1}^n I(M_2, M_3, F_2, F_3, Y^{i-1}, X_{2,i}, X_{3,i}; Y_i) \\
&\stackrel{(b)}{=} \sum_{i=1}^n I(X_{2,i}, X_{3,i}; Y_i),
\end{aligned}$$

where (a) follows from Fano's inequality (ignoring an $O(n\epsilon)$ term), (b) follows from the memorylessness of the channel and the independence of $X_{1,i}$ over $i = 1, \dots, n$ for the particular $p_{\mathbf{X}_1}$ under consideration.

Let $U \sim \text{Unif}\{1, 2, \dots, n\}$ independent of $(M_1, M_2, M_3, F_1, F_2, F_3, \mathbf{Y})$. We have (where we ignore an additive $O(\epsilon)$ term)

$$R_2 + R_3 \leq I(X_{2,U}, X_{3,U}; Y_U | U).$$

Since, the above bound holds for all $p_{\mathbf{X}_1}(\mathbf{x}_1) = \prod_{i=1}^n q_{X_{1,i}}(x_{1,i})$, and noticing that conditioned on $X_{1,U}, X_{2,U}, X_{3,U}$ the channel law $W_{Y|X_1 X_2 X_3}$ gives the conditional probability of Y_U , we may write

$$R_2 + R_3 \leq \min_{q(x_1|u)} I(X_2, X_3; Y | U) \quad (59)$$

for some $q(x_1|u)$. We note that the distribution of U, X_1, X_2, X_3, Y is $p(u)q(x_1|u)p(x_2|u)p(x_3|u)W_{Y|X_1 X_2 X_3}(y|x_1, x_2, x_3)$ where $p(x_2|u)$ is determined by the distribution of F_2 and $p(x_3|u)$ is determined by the distribution of F_3 .

Proceeding similarly, for $p_{\mathbf{X}_1}(\mathbf{x}_1) = \prod_{i=1}^n q_{X_{1,i}}(x_{1,i})$,

$$\begin{aligned}
nR_2 &\leq H(M_2) \\
&\leq H(M_2 | M_3, F_2, F_3) \\
&\approx I(M_2; \mathbf{Y} | M_3, F_2, F_3) \\
&= \sum_{i=1}^n I(M_2; Y_i | Y^{i-1}, M_3, F_2, F_3) \\
&= \sum_{i=1}^n I(M_2, X_{2,i}; Y_i | X_{3,i}, Y^{i-1}, M_3, F_2, F_3) \\
&\leq \sum_{i=1}^n I(X_{2,i}, Y^{i-1}, M_2, M_3, F_2, F_3; Y_i | X_{3,i}) \\
&= \sum_{i=1}^n I(X_{2,i}; Y_i | X_{3,i}).
\end{aligned}$$

Hence, we have

$$R_2 \leq \min_{q(x_1|u)} I(X_2; Y | X_3, U), \quad (60)$$

where the joint distribution of the random variables is $p(u)q(x_1|u)p(x_2|u)p(x_3|u)W_{Y|X_1X_2X_3}(y|x_1, x_2, x_3)$. We note that $p(u)p(x_2|u)p(x_3|u)$ are the same as in (59). Similarly,

$$R_3 \leq \min_{q(x_1|u)} I(X_3; Y|X_2, U). \quad (61)$$

Similarly, considering $P_{e,2}^{\text{weak}}$ with $p_{\mathbf{X}_2}(x_2^n) = \prod_{i=1}^n q_{X_{2,i}}(x_{2,i})$ (and $\mathbf{X}_i = F_i(W_i)$, $i = 1, 3$), we get

$$R_3 \leq \min_{q(x_2|u)} I(X_3; Y|X_1, U), \quad (62)$$

$$R_1 \leq \min_{q(x_2|u)} I(X_1; Y|X_3, U), \quad (63)$$

$$R_3 + R_1 \leq \min_{q(x_2|u)} I(X_3, X_1; Y|U), \quad (64)$$

where the joint distribution of the random variables is $p(u)p(x_1|u)q(x_2|u)p(x_3|u)W_{Y|X_1X_2X_3}(y|x_1, x_2, x_3)$ for some $q_{x_2|u}$. We note that $p(u)$ and $p(x_3|u)$ here are the same as in (59)-(61). Considering $P_{e,3}^{\text{weak}}$ with $p_{\mathbf{X}_3}(x_3^n) = \prod_{i=1}^n q_{X_{3,i}}(x_{3,i})$ (and $\mathbf{X}_i = F_i(W_i)$, $i = 1, 2$), we similarly arrive at

$$R_1 \leq \min_{q(x_3|u)} I(X_1; Y|X_3, U), \quad (65)$$

$$R_2 \leq \min_{q(x_3|u)} I(X_2; Y|X_2, U), \quad (66)$$

$$R_1 + R_2 \leq \min_{q(x_3|u)} I(X_1, X_2; Y|U), \quad (67)$$

where the joint distribution of the random variables is $p(u)p(x_1|u)p(x_2|u)q(x_3|u)W_{Y|X_1X_2X_3}(y|x_1, x_2, x_3)$. The $p(u)$, $p(x_1|u)$, and $p(x_2|u)$ are the same as in (59)-(67). By Caratheodory's theorem, it is enough to choose U such that $|\mathcal{U}| \leq 3$. This completes the proof of converse. \square

5 The k -user byzantine-MAC

In this section, we generalize our model to a k -user byzantine-MAC for any positive integer k . We allow for a set of users to behave maliciously simultaneously. The adversarial users can collude and mount a joint attack.

We study the problem under both randomized and deterministic codes. The techniques for the 3-user byzantine-MAC are extended to show the characterization of the randomized capacity region. For the deterministic part, we take the first approach (Section 1.4.2) as mentioned in the introduction. We first show that for any randomized code with vanishing probability of error, there exists another randomized code, also with vanishing probability of error, which requires only n^2 -valued randomness at each encoder for a code of blocklength n . This argument is along the lines of the extension of the elimination technique [13] provided in [8]. Next, we generalize the symmetrizability conditions to show that the deterministic coding capacity region has non-empty interior if and only if the byzantine-MAC is not symmetrizable. This allows us to use a small rate positive code to share the random bits with the decoder (also see Remark 3) whenever the channel is not symmetrizable and then use the randomized scheme to achieve the entire randomized capacity region under deterministic codes.

We give the system model in Section 5.1 and discuss the randomized and deterministic coding capacity regions in Sections 5.2 and 5.3 respectively. We only give proof sketches in these sections and defer the complete proofs to the appendices.

5.1 System model

A memoryless k -user byzantine-MAC (W, \mathcal{A}) consists of a k -user memoryless MAC W with input alphabets $\mathcal{X}_1, \mathcal{X}_2, \dots, \mathcal{X}_k$, and output alphabet \mathcal{Y} along with an adversary structure $\mathcal{A} \subseteq 2^{[1:k]}$ where $2^{[1:k]}$ denotes the power set of $[1 : k]$. Each element of the adversary structure denotes the allowed set of users which can turn malicious simultaneously. If

$\emptyset \in \mathcal{A}$, then it corresponds to the case when all users are honest. For the 3-user byzantine-MAC (Section 3) which considers the case when at most one user is malicious, the adversary structure is given by $\mathcal{A} = \{\emptyset, \{1\}, \{2\}, \{3\}\}$.

Definition 7 (Randomized code). An $(N_1, N_2, \dots, N_k, n)$ randomized *code* for the byzantine-MAC (W, \mathcal{A}) consists of the following:

- (i) k message sets, $\mathcal{M}_i = \{1, \dots, N_i\}$, $i = 1, 2, \dots, k$,
- (ii) k independent randomized encoders, $F_i : \mathcal{M}_i \rightarrow \mathcal{X}_i^n$, where $F_i \sim P_{F_i}$ takes values in $\mathcal{F}_i \subseteq \{g : \mathcal{M}_i \rightarrow \mathcal{X}_i^n\}$, $i = 1, 2, \dots, k$ and
- (iii) a decoder, $\phi : \mathcal{Y}^n \times \mathcal{F}_1 \times \mathcal{F}_2 \times \dots \times \mathcal{F}_k \rightarrow \mathcal{M}_1 \times \mathcal{M}_2 \times \dots \times \mathcal{M}_k$ where $\phi(\mathbf{y}, F_1, F_2, \dots, F_k) = (\phi_1(\mathbf{y}, F_1, F_2, \dots, F_k), \phi_2(\mathbf{y}, F_1, F_2, \dots, F_k), \dots, \phi_k(\mathbf{y}, F_1, F_2, \dots, F_k))$ for some deterministic functions $\phi_i : \mathcal{Y}^n \times \mathcal{F}_1 \times \mathcal{F}_2 \times \dots \times \mathcal{F}_k \rightarrow \mathcal{M}_1 \times \mathcal{M}_2 \times \dots \times \mathcal{M}_k$, $i = 1, 2, \dots, k$.

Similar to the 3-user case, we define the probability of error and capacity region under three different adversary models. In the standard setting where the adversarial users can choose their inputs to the channel based on the knowledge of random encoding maps, we denote the *randomized coding capacity region* by $\mathcal{R}_{\text{random}}$. Recall that the strong and weak adversaries are defined as follows – (i) set of adversaries $\mathcal{Q} \in \mathcal{A}$ are *strong* adversaries if they may choose their encoding maps $f_{\mathcal{Q}}$ (i.e., $(f_i)_{i \in \mathcal{Q}}$) in addition to the input vectors $\mathbf{x}_{\mathcal{Q}}$, and (ii) a set of adversaries are *weak* adversaries if they do not have any knowledge of their random encoding maps when choosing their input vectors. We denote the corresponding randomized coding capacity region by $\mathcal{R}_{\text{random}}^{\text{strong}}$ and $\mathcal{R}_{\text{random}}^{\text{weak}}$ respectively. As was the case in 3-user byzantine-MAC, $\mathcal{R}_{\text{random}}^{\text{strong}} \subseteq \mathcal{R}_{\text{random}} \subseteq \mathcal{R}_{\text{random}}^{\text{weak}}$.

Let $P_{e, \mathcal{Q}}^{\text{strong}}$ denote the average probability of error when the set \mathcal{Q} of users are adversarial (under the strong adversary model).

$$P_{e, \mathcal{Q}}^{\text{strong}} = \max_{\mathbf{x}_{\mathcal{Q}}, f_{\mathcal{Q}} \in \mathcal{F}_{\mathcal{Q}}} \frac{1}{\left(\prod_{i \in \mathcal{Q}^c} N_i\right)} \sum_{m_{\mathcal{Q}^c} \in \mathcal{M}_{\mathcal{Q}^c}} \mathbb{P}(\{\phi(\mathbf{Y}, f_{\mathcal{Q}}, F_{\mathcal{Q}^c})_{\mathcal{Q}^c} \neq m_{\mathcal{Q}^c}\} | \mathbf{X}_{\mathcal{Q}^c} = F_{\mathcal{Q}^c}(m_{\mathcal{Q}^c}), \mathbf{X}_{\mathcal{Q}} = \mathbf{x}_{\mathcal{Q}}), \quad (68)$$

where $\phi(\mathbf{y}, f_{\mathcal{Q}}, f_{\mathcal{Q}^c})_{\mathcal{Q}^c}$ denotes $\hat{m}_{\mathcal{Q}^c}$ for some $\hat{m}_{[1:k]} \in \mathcal{M}_{[1:k]}$ such that $\phi(\mathbf{y}, f_{\mathcal{Q}}, f_{\mathcal{Q}^c}) = \hat{m}_{[1:k]}$.

The average probability of error P_e^{strong} is given by

$$P_e^{\text{strong}} = \max_{\mathcal{Q} \in \mathcal{A}} P_{e, \mathcal{Q}}^{\text{strong}}.$$

Note that though the adversaries do not use $f_{\mathcal{Q}}$ for encoding, the decoder uses it, and hence its choice gives the adversaries additional power. We also emphasize that the decoder is unaware of which set of adversaries from \mathcal{A} is active (i.e., in (68), the decoding map ϕ may not depend of \mathcal{Q}).

We say a rate tuple (R_1, R_2, \dots, R_k) is *achievable* against the strong adversary, if there is a sequence of $(\lfloor 2^{nR_1} \rfloor, \lfloor 2^{nR_2} \rfloor, \dots, \lfloor 2^{nR_k} \rfloor)$ codes $(F_1^{(n)}, F_2^{(n)}, \dots, F_k^{(n)}, \phi^{(n)})_{n=1}^{\infty}$ such that $\lim_{n \rightarrow \infty} P_{e, \mathcal{Q}}^{\text{strong}}(F_1^{(n)}, F_2^{(n)}, \dots, F_k^{(n)}, \phi^{(n)}) \rightarrow 0$. The *strong randomized coding capacity region* $\mathcal{R}_{\text{random}}^{\text{strong}}$ is the closure of the set of all achievable rate triples.

Probability of error and capacity region for randomized codes with weak adversary can be defined by replacing $P_{e, \mathcal{Q}}^{\text{strong}}$ with $P_{e, \mathcal{Q}}^{\text{weak}}$ for $\mathcal{Q} \in \mathcal{A}$ in the above definition, where

$$P_{e, \mathcal{Q}}^{\text{weak}} = \max_{\mathbf{x}_{\mathcal{Q}}} \frac{1}{\left(\prod_{i \in \mathcal{Q}^c} N_i\right)} \sum_{m_{\mathcal{Q}^c} \in \mathcal{M}_{\mathcal{Q}^c}} \mathbb{P}(\{\phi(\mathbf{Y}, F_{\mathcal{Q}}, F_{\mathcal{Q}^c})_{\mathcal{Q}^c} \neq m_{\mathcal{Q}^c}\} | \mathbf{X}_{\mathcal{Q}^c} = F_{\mathcal{Q}^c}(m_{\mathcal{Q}^c}), \mathbf{X}_{\mathcal{Q}} = \mathbf{x}_{\mathcal{Q}}), \quad (69)$$

For the standard adversary who has access to the random encoding map but is not allowed to choose it, the probability of error and capacity region can be defined in a similar fashion, by replacing $P_{e, \mathcal{Q}}^{\text{strong}}$ with $P_{e, \mathcal{Q}}^{\text{rand}}$, $\mathcal{Q} \in \mathcal{A}$. We define $P_{e, \mathcal{Q}}^{\text{rand}}$ below.

$$P_{e, \mathcal{Q}}^{\text{rand}} = \max_{\mathbf{x}_{\mathcal{Q}}: \mathcal{F}_{\mathcal{Q}} \rightarrow \mathcal{X}_{\mathcal{Q}}^n} \frac{1}{\left(\prod_{i \in \mathcal{Q}^c} N_i\right)} \sum_{m_{\mathcal{Q}^c} \in \mathcal{M}_{\mathcal{Q}^c}} \mathbb{P}(\{\phi(\mathbf{Y}, F_{\mathcal{Q}}, F_{\mathcal{Q}^c})_{\mathcal{Q}^c} \neq m_{\mathcal{Q}^c}\} | \mathbf{X}_{\mathcal{Q}^c} = F_{\mathcal{Q}^c}(m_{\mathcal{Q}^c}), \mathbf{X}_{\mathcal{Q}} = \mathbf{x}_{\mathcal{Q}}), \quad (70)$$

The notation $\mathbf{x}_{\mathcal{Q}} : \mathcal{F}_{\mathcal{Q}} \rightarrow \mathcal{X}_{\mathcal{Q}}^n$ signifies that the adversary can choose the sequence $\mathbf{x}_{\mathcal{Q}}$ with the knowledge of the encoding map $F_{\mathcal{Q}} \sim P_{F_{\mathcal{Q}}}$. The capacity region in this setting is denoted by $\mathcal{R}_{\text{random}}$.

Definition 8 (Deterministic code). An $(N_1, N_2, \dots, N_k, n)$ deterministic *code* for the byzantine-MAC (W, \mathcal{A}) consists of:

- (i) k message sets, $\mathcal{M}_i = \{1, \dots, N_i\}$, $i \in \{1, 2, \dots, k\}$,
- (ii) k encoders, $f_i : \mathcal{M}_i \rightarrow \mathcal{X}_i^n$, $i \in \{1, 2, \dots, k\}$, and
- (iii) a decoder, $\phi : \mathcal{Y}^n \rightarrow \mathcal{M}_1 \times \mathcal{M}_2 \times \dots \times \mathcal{M}_k$.

Let $P_{e, \mathcal{Q}}$ denote the average probability of error when the set \mathcal{Q} of users are adversarial.

$$P_{e, \mathcal{Q}} = \max_{\mathbf{x}_{\mathcal{Q}}} \frac{1}{\left(\prod_{i \in \mathcal{Q}^c} N_i\right)} \sum_{m_{\mathcal{Q}^c} \in \mathcal{M}_{\mathcal{Q}^c}} \mathbb{P}(\{\phi(\mathbf{Y})_{\mathcal{Q}^c} \neq m_{\mathcal{Q}^c}\} | \mathbf{X}_{\mathcal{Q}^c} = f_{\mathcal{Q}^c}(m_{\mathcal{Q}^c}), \mathbf{X}_{\mathcal{Q}} = \mathbf{x}_{\mathcal{Q}}). \quad (71)$$

The average probability of error P_e is given by

$$P_e = \max_{\mathcal{Q} \in \mathcal{A}} P_{e, \mathcal{Q}}.$$

Similar to the randomized coding case, the decoder is unaware of which set of adversaries from \mathcal{A} is active.

We say a rate tuple (R_1, R_2, \dots, R_k) is *achievable* if there is a sequence of $(\lfloor 2^{nR_1} \rfloor, \lfloor 2^{nR_2} \rfloor, \dots, \lfloor 2^{nR_k} \rfloor, n)$ codes $(f_1^{(n)}, f_2^{(n)}, \dots, f_k^{(n)}, \phi^{(n)})_{n=1}^{\infty}$ such that $\lim_{n \rightarrow \infty} P_e(f_1^{(n)}, f_2^{(n)}, \dots, f_k^{(n)}, \phi^{(n)}) \rightarrow 0$. The *deterministic coding capacity region* $\mathcal{R}_{\text{deterministic}}$ is the set of all achievable rate tuples.

Recall that for the three user byzantine-MAC (Section 3, where the adversary structure is $\mathcal{A} = \{\emptyset, \{1\}, \{2\}, \{3\}\}$), we could show that $P_{e,0} \leq P_{e,1} + P_{e,2} + P_{e,3}$ (see (3)). Generalizing this to the k -user byzantine-MAC (W, \mathcal{A}) , we can show the following lemma whose proof is in Appendix C.

Lemma 6. For any $\mathcal{Q}_1, \dots, \mathcal{Q}_t \in \mathcal{A}$, $t \in \mathbb{N}$ and $\mathcal{Q} \subseteq [1 : k]$ such that $\mathcal{Q} = \cap_{i=1}^t \mathcal{Q}_i$, $P_{e, \mathcal{Q}} \leq \sum_{i=1}^t P_{e, \mathcal{Q}_i}$.

This lemma implies that even if a set $\mathcal{Q} = \cap_{i=1}^t \mathcal{Q}_i$ as in Lemma 6 is removed from \mathcal{A} , the capacity region of a byzantine-MAC remains unchanged.

5.2 Randomized coding capacity region

Let \mathcal{R} be the closure of the set of all rate tuples (R_1, R_2, \dots, R_k) such that for some $p(u)p(x_1|u)p(x_2|u) \dots p(x_k|u)$, the following conditions hold for all $\mathcal{Q} \in \mathcal{A}$ and $\mathcal{J} \subseteq \mathcal{Q}^c$,

$$\sum_{j \in \mathcal{J}} R_j \leq \min_{q(\mathbf{x}_{\mathcal{Q}}|u)} I(X_{\mathcal{J}}; Y | X_{(\mathcal{Q} \cup \mathcal{J})^c}) \quad (72)$$

where the mutual information above is evaluated using the joint distribution $p(u)q(\mathbf{x}_{\mathcal{Q}}|u) \prod_{j \in \mathcal{Q}^c} p(x_j|u)W(y|\mathbf{x}_{\mathcal{Q}}, \mathbf{x}_{\mathcal{Q}^c})$. Here $|\mathcal{U}| \leq k$.

Theorem 7. For a k -user byzantine-MAC,

$$\mathcal{R}_{\text{random}}^{\text{strong}} = \mathcal{R}_{\text{random}} = \mathcal{R}_{\text{random}}^{\text{weak}} = \mathcal{R}.$$

Similar to the three user case (Section 3.2.2), we prove Theorem 7 by showing an achievability for the strong adversary and a converse for the weak adversary. The converse can be proved by a simple extension of the converse of Theorem 3 (three-user randomized coding capacity region) and is skipped. The achievability uses arguments similar to the proof of achievability of Theorem 3. It is shown in Appendix D.

5.3 Deterministic coding capacity region

Similar to the 3-user case (Section 3.2.1), we first give a general the symmetrizability condition which characterize the class of channels under which all users cannot communicate reliably in a byzantine-MAC (W, \mathcal{A}) using deterministic codes. For the 3-user byzantine-MAC case, this condition (given below) specialized to the three conditions (5)-(7).

Definition 9 (Symmetrizability and symmetrizable byzantine-MAC). For a non-empty set $\mathcal{T} \subseteq [1 : k]$, we say that a byzantine-MAC (W, \mathcal{A}) is \mathcal{T} -*symmetrizable* if there exist sets $\mathcal{Q}, \mathcal{Q}' \in \mathcal{A}$, not necessarily distinct, satisfying $\mathcal{Q} \cap \mathcal{T} = \mathcal{Q}' \cap \mathcal{T} = \emptyset$, and a pair of conditional distributions $P_{X_{\mathcal{Q}}|X_{\mathcal{T} \cup (\mathcal{Q} \setminus \mathcal{Q}')}}$ and $P'_{X_{\mathcal{Q}'}|X_{\mathcal{T} \cup (\mathcal{Q}' \setminus \mathcal{Q})}}$ such that

$$\begin{aligned} & \sum_{x'_{\mathcal{Q}} \in \mathcal{X}_{\mathcal{Q}}} P_{X_{\mathcal{Q}}|X_{\mathcal{T} \cup (\mathcal{Q} \setminus \mathcal{Q}')}}(x'_{\mathcal{Q}}|x_{\mathcal{T}}, x_{\mathcal{Q} \setminus \mathcal{Q}'})W(y|x'_{\mathcal{Q}}, \tilde{x}_{\mathcal{T}}, x_{\mathcal{Q}' \setminus \mathcal{Q}}, x_{(\mathcal{T} \cup \mathcal{Q} \cup \mathcal{Q}')^c}) \\ &= \sum_{\tilde{x}_{\mathcal{Q}'} \in \mathcal{X}_{\mathcal{Q}'}} P'_{X_{\mathcal{Q}'}|X_{\mathcal{T} \cup (\mathcal{Q}' \setminus \mathcal{Q})}}(\tilde{x}_{\mathcal{Q}'}|\tilde{x}_{\mathcal{T}}, x_{\mathcal{Q}' \setminus \mathcal{Q}})W(y|\tilde{x}_{\mathcal{Q}'}, x_{\mathcal{T}}, x_{\mathcal{Q} \setminus \mathcal{Q}'}, x_{(\mathcal{T} \cup \mathcal{Q} \cup \mathcal{Q}')^c}) \end{aligned} \quad (73)$$

for all $x_{\mathcal{T}}, \tilde{x}_{\mathcal{T}} \in \mathcal{X}_{\mathcal{T}}$, $x_{\mathcal{Q} \setminus \mathcal{Q}'} \in \mathcal{X}_{\mathcal{Q} \setminus \mathcal{Q}'}$, $x_{\mathcal{Q}' \setminus \mathcal{Q}} \in \mathcal{X}_{\mathcal{Q}' \setminus \mathcal{Q}}$, $x_{(\mathcal{T} \cup \mathcal{Q} \cup \mathcal{Q}')^c} \in \mathcal{X}_{(\mathcal{T} \cup \mathcal{Q} \cup \mathcal{Q}')^c}$ and $y \in \mathcal{Y}$. We say that a byzantine-MAC (W, \mathcal{A}) is *symmetrizable* if it is \mathcal{T} -symmetrizable for any $\mathcal{T} \neq \emptyset$.

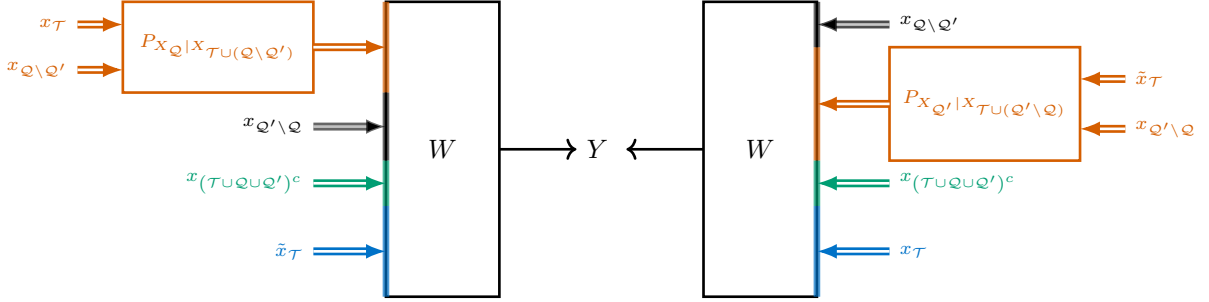

Figure 13: For each $(\tilde{x}_{\mathcal{T}}, x_{\mathcal{T}}, x_{\mathcal{Q} \setminus \mathcal{Q}'}, x_{\mathcal{Q}' \setminus \mathcal{Q}}, x_{\mathcal{T} \cup \mathcal{Q} \cup \mathcal{Q}'^c})$, the conditional output distributions in the two cases above are the same. Thus, the receiver is unable to tell whether the users in set \mathcal{T} are sending $\tilde{x}_{\mathcal{T}}$ or $x_{\mathcal{T}}$.

Fig. 13 illustrates the symmetrizability condition in (73). The set \mathcal{T} of users are being symmetrized by adversary sets $\mathcal{Q}, \mathcal{Q}' \in \mathcal{A}$. The users not in $\mathcal{T} \cup \mathcal{Q} \cup \mathcal{Q}'$ are not symmetrized. Definition 9 extends the notion of symmetrizability for the three users case (Definition 5) to the k -user byzantine-MAC with adversary structure \mathcal{A} . It generalizes the three conditions (5)-(7) to a single condition given by (73). In particular, $\mathcal{T} = \{j, k\}$ and $\mathcal{Q} = \mathcal{Q}' = \{i\}$ recovers (5), $\mathcal{T} = \{k\}$ and $\mathcal{Q} = \mathcal{Q}' = \{i\}$ recovers (6), and $\mathcal{T} = \{k\}$, $\mathcal{Q} = \{i\}$ and $\mathcal{Q}' = \{j\}$ recovers (7). Now, we are ready to state our main result.

Theorem 8. If a byzantine-MAC (W, \mathcal{A}) is symmetrizable, then $\text{int}(\mathcal{R}_{\text{deterministic}}) = \emptyset$. Otherwise, $\mathcal{R}_{\text{deterministic}} = \mathcal{R}_{\text{random}}$.

Proof sketch. For the *converse*, similar to the 3-user case, we show in Appendix H that if a channel is symmetrizable then $\text{int}(\mathcal{R}_{\text{deterministic}}) = \emptyset$. When the channel is not symmetrizable, the outer bound on the rate region is given by Theorem 7. As mentioned, towards the *achievability* side of the theorem we take the first approach (Section 1.4.2) discussed in the introduction. We first show the following lemma (proved in Appendix G) which shows that all users can communicate at positive rates if a byzantine-MAC is not symmetrizable.

Lemma 9. If a byzantine-MAC is not symmetrizable, then there exists $(R_1, R_2, \dots, R_k) \in \mathcal{R}_{\text{deterministic}}$ where $R_i > 0$ for all $i \in [1 : k]$.

Next, we show that for every randomized code with small probability of error, there exists another randomized code, also with a small probability of error, which requires only n^2 -valued randomness at each encoder for a code

of blocklength n . This argument is along the lines of the extension of the elimination technique [13] given in Jahn [8, Theorem 1]. The formal statement and the proof is given in Appendix E.

Combining these two results, we show the following lemma, which is along the lines of the proof of [27, Theorem 12.11]. This completes the proof of Theorem 8.

Lemma 10. For a byzantine-MAC, if there exists $(R_1, R_2, \dots, R_k) \in \mathcal{R}_{\text{deterministic}}$ where $R_i > 0$ for all $i \in [1 : k]$, then $\mathcal{R}_{\text{deterministic}} \supseteq \mathcal{R}_{\text{random}}$.

The proof of Lemma 10 is given in Appendix F. \square

Similar to the 3-user case, the proof of Lemma 9 (formally given in Appendix G) employs a codebook generated using a random coding argument (see Lemma 17 in Appendix G) and is along the lines of [10, Lemma 2] and [22, Lemma 3]. The decoder is a generalization of 3-user decoder given in Definition 6 and is defined below.

Definition 10 (Decoder). For $\eta > 0$, and encoding maps, $f_i : \mathcal{M}_i \rightarrow \mathcal{X}_i^n$ for $i \in [1 : k]$, the decoding set $\mathcal{D}_{m_1, m_2, \dots, m_k} \subseteq \mathcal{Y}^n$ of the message tuple $(m_1, m_2, \dots, m_k) \in \mathcal{M}_1 \times \mathcal{M}_2 \times \dots \times \mathcal{M}_k$ is defined as the intersection of the sets $\mathcal{D}_{m_i}^{(i)}$, $i \in [1 : k]$, i.e., $\mathcal{D}_{m_1, m_2, \dots, m_k} \stackrel{\text{def}}{=} \bigcap_{i=1}^k \mathcal{D}_{m_i}^{(i)}$, where the sets $\mathcal{D}_{m_i}^{(i)}$, $i \in [1 : k]$ are defined as follows:

A sequence $\mathbf{y} \in \mathcal{D}_{m_i}^{(i)}$, $i \in [1 : k]$, if there exists $\mathcal{Q} \in \mathcal{A}$, $i \notin \mathcal{Q}$, $\mathbf{x}_{\mathcal{Q}} \in \mathcal{X}_{\mathcal{Q}}^n$, $\tilde{m}_{\mathcal{Q}^c} \in \mathcal{M}_{\mathcal{Q}^c}$ where $\tilde{m}_i = m_i$ and random variables $X_{\mathcal{Q}^c}$, $X_{\mathcal{Q}}$ and Y with $(f_{\mathcal{Q}^c}(\tilde{m}_{\mathcal{Q}^c}), \mathbf{x}_{\mathcal{Q}}, \mathbf{y}) \in T_{X_{\mathcal{Q}^c} X_{\mathcal{Q}} Y}^n$, satisfying the following:

1. $D(P_{X_{\mathcal{Q}^c} X_{\mathcal{Q}} Y} \| (\prod_{i \in \mathcal{Q}^c} P_{X_i}) P_{X_{\mathcal{Q}}} W) < \eta$.
2. Suppose there exist $\mathcal{Q}' \in \mathcal{A}$, not necessarily distinct from \mathcal{Q} , a non-empty set $\mathcal{T} \subseteq (\mathcal{Q} \cup \mathcal{Q}')^c$ with $i \in \mathcal{T}$, $\mathbf{x}'_{\mathcal{Q}'}, m'_{\mathcal{Q} \setminus \mathcal{Q}'} \in \mathcal{M}_{\mathcal{Q} \setminus \mathcal{Q}'}$, $m'_{\mathcal{T}} \in \mathcal{M}_{\mathcal{T}}$ such that $m'_t \neq \tilde{m}_t$ for all $t \in \mathcal{T}$ such that for the joint distribution $P_{X_{\mathcal{Q}^c} X_{\mathcal{Q}} X'_{\mathcal{T}} X'_{\mathcal{Q} \setminus \mathcal{Q}'} X'_{\mathcal{Q}'}, Y}$ defined by $(f_{\mathcal{Q}^c}(\tilde{m}_{\mathcal{Q}^c}), \mathbf{x}_{\mathcal{Q}}, f_{\mathcal{T}}(m'_{\mathcal{T}}), f_{\mathcal{Q} \setminus \mathcal{Q}'}(m'_{\mathcal{Q} \setminus \mathcal{Q}'}), \mathbf{x}'_{\mathcal{Q}'}, \mathbf{y}) \in T_{X_{\mathcal{Q}^c} X_{\mathcal{Q}} X'_{\mathcal{T}} X'_{\mathcal{Q} \setminus \mathcal{Q}'} X'_{\mathcal{Q}'}, Y}^n$,

$$D(P_{X'_{\mathcal{T}} X'_{\mathcal{Q} \setminus \mathcal{Q}'} X_{\mathcal{Q}^c \setminus (\mathcal{T} \cup \mathcal{Q}')} X'_{\mathcal{Q}'}, Y} \| (\prod_{t \in \mathcal{T}} P_{X_t}) (\prod_{j \in \mathcal{Q} \setminus \mathcal{Q}'} P_{X'_j}) (\prod_{l \in \mathcal{Q}^c \setminus (\mathcal{T} \cup \mathcal{Q}')} P_{X_l}) P_{X'_{\mathcal{Q}'}} W) < \eta. \quad (74)$$

Then,

$$I(X_{\mathcal{Q}^c} Y; X'_{\mathcal{T}} X'_{\mathcal{Q} \setminus \mathcal{Q}'} | X_{\mathcal{Q}}) < \eta. \quad (75)$$

In the definition of $\mathcal{D}_{m_i}^{(i)}$ above, condition 1 checks for typicality with respect to channel inputs $(f_j(\tilde{m}_j), j \in \mathcal{Q}^c)$ and $\mathbf{x}_{\mathcal{Q}}$. Under condition (74), where an alternative input to the channel $(f_t(m'_t), t \in \mathcal{T})$, $(f_j(m'_j), j \in \mathcal{Q} \setminus \mathcal{Q}')$, $(f_l(m_l), l \in \mathcal{Q}^c \setminus (\mathcal{T} \cup \mathcal{Q}'))$ and $\mathbf{x}'_{\mathcal{Q}'}$ looks typical, condition (75) implies that the input $(f_j(\tilde{m}_j), j \in \mathcal{Q}^c)$ and $\mathbf{x}_{\mathcal{Q}}$ is a more plausible explanation for the channel output than the alternative input (see Fig. 13).

As mentioned earlier, Definition 10 is a generalization of 3-user decoder in Definition 6. In particular, check (a) can be obtained by setting $\mathcal{Q} = \mathcal{Q}' = \{3\}$ and $\mathcal{T} = \{1, 2\}$, (b) by setting $\mathcal{Q} = \mathcal{Q}' = \{3\}$ and $\mathcal{T} = \{1\}$ and (c) by setting $\mathcal{Q} = \{3\}$, $\mathcal{Q}' = \{2\}$ and $\mathcal{T} = \{1\}$.

Similar to Lemma 2, we can show that for small enough $\eta > 0$, $\mathcal{D}_{m_1, m_2, \dots, m_k} \cap \mathcal{D}_{\tilde{m}_1, \tilde{m}_2, \dots, \tilde{m}_k} = \emptyset$ for every $(m_1, m_2, \dots, m_k) \neq (\tilde{m}_1, \tilde{m}_2, \dots, \tilde{m}_k)$. See Lemma 19 in Appendix G for the formal statement and proof.

References

- [1] N. Sangwan, M. Bakshi, B. K. Dey, and V. M. Prabhakaran, "Multiple access channels with byzantine users," in *2019 IEEE Information Theory Workshop (ITW)*, pp. 1–5, 2019.
- [2] A. Burg, A. Chattopadhyay, and K.-Y. Lam, "Wireless communication and security issues for cyber-physical systems and the internet-of-things," *Proceedings of the IEEE*, vol. 106, no. 1, pp. 38–60, 2018.
- [3] M. Ammar, G. Russello, and B. Crispo, "Internet of things: A survey on the security of iot frameworks," *Journal of Information Security and Applications*, vol. 38, pp. 8–27, 2018.

- [4] A. D. Wyner, “The wire-tap channel,” *Bell system technical journal*, vol. 54, no. 8, pp. 1355–1387, 1975.
- [5] D. Blackwell, L. Breiman, and A. Thomasian, “The capacities of certain channel classes under random coding,” *The Annals of Mathematical Statistics*, vol. 31, no. 3, pp. 558–567, 1960.
- [6] A. Lapidoth and P. Narayan, “Reliable communication under channel uncertainty,” *IEEE transactions on Information Theory*, vol. 44, no. 6, pp. 2148–2177, 1998.
- [7] A. Beemer, E. Graves, J. Kliewer, O. Kosut, and P. Yu, “Authentication and partial message correction over adversarial multiple-access channels,” in *2020 IEEE Conference on Communications and Network Security (CNS)*, pp. 1–6, IEEE, 2020.
- [8] J.-H. Jahn, “Coding of arbitrarily varying multiuser channels,” *IEEE Transactions on Information Theory*, vol. 27, no. 2, pp. 212–226, 1981.
- [9] J. A. Gubner, “On the deterministic-code capacity of the multiple-access arbitrarily varying channel,” *IEEE transactions on information theory*, vol. 36, no. 2, pp. 262–275, 1990.
- [10] R. Ahlswede and N. Cai, “Arbitrarily varying multiple-access channels. i. ericson’s symmetrizability is adequate, gubner’s conjecture is true,” *IEEE Transactions on Information Theory*, vol. 45, no. 2, pp. 742–749, 1999.
- [11] U. Pereg and Y. Steinberg, “The capacity region of the arbitrarily varying mac: with and without constraints,” in *2019 IEEE International Symposium on Information Theory (ISIT)*, pp. 445–449, IEEE, 2019.
- [12] M. Wiese and H. Boche, “The arbitrarily varying multiple-access channel with conferencing encoders,” *IEEE transactions on information theory*, vol. 59, no. 3, pp. 1405–1416, 2012.
- [13] R. Ahlswede, “Elimination of correlation in random codes for arbitrarily varying channels,” *Zeitschrift für Wahrscheinlichkeitstheorie und verwandte Gebiete*, vol. 44, no. 2, 1978.
- [14] O. Kosut, L. Tong, and N. David, “Polytope codes against adversaries in networks,” *IEEE transactions on information theory*, vol. 60, no. 6, pp. 3308–3344, 2014.
- [15] S. Jaggi, M. Langberg, S. Katti, T. Ho, D. Katabi, and M. Médard, “Resilient network coding in the presence of byzantine adversaries,” in *IEEE INFOCOM 2007-26th IEEE international conference on computer communications*, pp. 616–624, IEEE, 2007.
- [16] D. Wang, D. Silva, and F. R. Kschischang, “Robust network coding in the presence of untrusted nodes,” *IEEE Transactions on Information Theory*, vol. 56, no. 9, pp. 4532–4538, 2010.
- [17] X. He and A. Yener, “Strong secrecy and reliable byzantine detection in the presence of an untrusted relay,” *IEEE transactions on information theory*, vol. 59, no. 1, pp. 177–192, 2012.
- [18] R. J. La and V. Anantharam, “A game-theoretic look at the gaussian multiaccess channel,” *DIMACS series in discrete mathematics and theoretical computer science*, vol. 66, pp. 87–106, 2004.
- [19] N. Sangwan, M. Bakshi, B. K. Dey, and V. M. Prabhakaran, “Multiple access channels with adversarial users,” in *2019 IEEE International Symposium on Information Theory (ISIT)*, pp. 435–439, IEEE, 2019.
- [20] N. Sangwan, M. Bakshi, B. K. Dey, and V. M. Prabhakaran, “Communication with adversary identification in byzantine multiple access channels,” in *2021 IEEE International Symposium on Information Theory (ISIT)*, pp. 688–693, IEEE, 2021.
- [21] T. Ericson, “Exponential error bounds for random codes in the arbitrarily varying channel,” *IEEE Transactions on Information Theory*, vol. 31, no. 1, pp. 42–48, 1985.

- [22] I. Csiszár and P. Narayan, “The capacity of the arbitrarily varying channel revisited: Positivity, constraints,” *IEEE transactions on Information Theory*, vol. 34, no. 2, pp. 181–193, 1988.
- [23] S. Janson and A. Ruciński, “The deletion method for upper tail estimates,” *Combinatorica*, vol. 24, no. 4, pp. 615–640, 2004.
- [24] M. Fitzzi, M. Hirt, and U. Maurer, “General adversaries in unconditional multi-party computation,” in *International Conference on the Theory and Application of Cryptology and Information Security*, pp. 232–246, Springer, 1999.
- [25] M. Hirt and U. Maurer, “Player simulation and general adversary structures in perfect multiparty computation,” *Journal of cryptology*, vol. 13, no. 1, pp. 31–60, 2000.
- [26] T. Wu, S. Zhu, F. Li, and L. Liu, “Two quantum secret sharing schemes with adversary structure,” *International Journal of Theoretical Physics*, vol. 61, no. 7, pp. 1–21, 2022.
- [27] I. Csiszár and J. Körner, *Information theory: coding theorems for discrete memoryless systems*. Cambridge University Press, 2011.

A Proof of Lemma 2

Proof. Suppose $\mathbf{y} \in \mathcal{Y}^n$ is such that $\mathbf{y} \in \mathcal{D}_{m_1}^{(1)} \cap \mathcal{D}_{\tilde{m}_1}^{(1)}$ for $m_1, \tilde{m}_1 \in \mathcal{M}_1$ where $\tilde{m}_1 \neq m_1$. Then there exist permutations (i, j) and (\tilde{i}, \tilde{j}) of (2, 3) such that one of the following cases holds.

Case 1: $(\tilde{i}, \tilde{j}) = (i, j)$

There exist $m_j, \tilde{m}_j \in \mathcal{M}_j$, sequences $\mathbf{x}_i, \tilde{\mathbf{x}}_i \in \mathcal{X}_i^n$, and random variables $X_1, \tilde{X}_1, X_j, \tilde{X}_j, X_i, \tilde{X}_i$ with $(f_1(m_1), f_1(\tilde{m}_1), f_j(m_j), f_j(\tilde{m}_j), \mathbf{x}_i, \tilde{\mathbf{x}}_i) \in T_{X_1 \tilde{X}_1 X_j \tilde{X}_j X_i \tilde{X}_i}^n$ such that $D(P_{X_1 X_j X_i Y} \| P_{X_1} \times P_{X_j} \times P_{X_i} \times W), D(P_{\tilde{X}_1 \tilde{X}_j \tilde{X}_i Y} \| P_{\tilde{X}_1} \times P_{\tilde{X}_j} \times P_{\tilde{X}_i} \times W) < \eta$ and

Case 1(a) if $\tilde{m}_j \neq m_j$, then $I(X_1 X_j Y; \tilde{X}_1 \tilde{X}_j | X_i), I(\tilde{X}_1 \tilde{X}_j Y; X_1 X_j | \tilde{X}_i) < \eta$.

Case 1(b) if $\tilde{m}_j = m_j$, then $\tilde{X}_j = X_j$ and $I(X_1 X_j Y; \tilde{X}_1 | X_i), I(\tilde{X}_1 X_j Y; X_1 | \tilde{X}_i) < \eta$.

Case 2: $(\tilde{i}, \tilde{j}) = (j, i)$

There exist $m_j \in \mathcal{M}_j, \tilde{m}_i \in \mathcal{M}_i$, sequences $\tilde{\mathbf{x}}_j \in \mathcal{X}_j^n, \mathbf{x}_i \in \mathcal{X}_i^n$ and random variables $X_1, \tilde{X}_1, X_j, \tilde{X}_j, X_i, \tilde{X}_i$ with $(f_1(m_1), f_1(\tilde{m}_1), f_j(m_j), \tilde{\mathbf{x}}_j, \mathbf{x}_i, f_i(\tilde{m}_i)) \in T_{X_1 \tilde{X}_1 X_j \tilde{X}_j X_i \tilde{X}_i}^n$ such that $D(P_{X_1 X_j X_i Y} \| P_{X_1} \times P_{X_j} \times P_{X_i} \times W), D(P_{\tilde{X}_1 \tilde{X}_j \tilde{X}_i Y} \| P_{\tilde{X}_1} \times P_{\tilde{X}_j} \times P_{\tilde{X}_i} \times W) < \eta$ and $I(X_1 X_j Y; \tilde{X}_1 \tilde{X}_i | X_i), I(\tilde{X}_1 \tilde{X}_i Y; X_1 X_j | \tilde{X}_j) < \eta$.

We first analyze **Case 1(a)**. Let $W_{Y|X_1 X_j X_i}$ be denoted by W .

$$\begin{aligned}
& D(P_{X_1 X_j X_i Y} \| P_{X_1} \times P_{X_j} \times P_{X_i} \times W) + D(P_{\tilde{X}_1, \tilde{X}_j} \| P_{\tilde{X}_1} \times P_{\tilde{X}_j}) + I(X_1 X_j Y; \tilde{X}_1 \tilde{X}_j | X_i) \stackrel{(a)}{=} \\
& \sum_{x_1, x_j, x_i, y} P_{X_1 X_j X_i Y}(x_1, x_j, x_i, y) \log \frac{P_{X_1 X_j X_i Y}(x_1, x_j, x_i, y)}{P_{X_1}(x_1) P_{X_j}(x_j) P_{X_i}(x_i) W(y|x_1, x_j, x_i)} + \sum_{\tilde{x}_1, \tilde{x}_j} P_{\tilde{X}_1 \tilde{X}_j}(\tilde{x}_1, \tilde{x}_j) \log \frac{P_{\tilde{X}_1 \tilde{X}_j}(\tilde{x}_1, \tilde{x}_j)}{P_{\tilde{X}_1}(\tilde{x}_1) P_{\tilde{X}_j}(\tilde{x}_j)} \\
& + \sum_{x_1, \tilde{x}_1, x_j, \tilde{x}_j, x_i, y} P_{X_1 \tilde{X}_1 X_j \tilde{X}_j X_i Y}(x_1, \tilde{x}_1, x_j, \tilde{x}_j, x_i, y) \log \frac{P_{X_1 \tilde{X}_1 X_j \tilde{X}_j X_i Y}(x_1, \tilde{x}_1, x_j, \tilde{x}_j, y|x_i)}{P_{X_1 X_j Y|X_i}(x_1, x_j, y|x_i) P_{\tilde{X}_1 \tilde{X}_j|X_i}(\tilde{x}_1, \tilde{x}_j|x_i)} \\
& = \sum_{x_1, \tilde{x}_1, x_j, \tilde{x}_j, x_i, y} P_{X_1 \tilde{X}_1 X_j \tilde{X}_j X_i Y}(x_1, \tilde{x}_1, x_j, \tilde{x}_j, x_i, y) \log \frac{P_{X_1 \tilde{X}_1 X_j \tilde{X}_j X_i Y}(x_1, \tilde{x}_1, x_j, \tilde{x}_j, x_i, y)}{P_{X_1}(x_1) P_{\tilde{X}_1}(\tilde{x}_1) P_{X_j}(x_j) P_{\tilde{X}_j}(\tilde{x}_j) P_{X_i|\tilde{X}_1 \tilde{X}_j}(x_i|\tilde{x}_1, \tilde{x}_j) W(y|x_1, x_j, x_i)} \\
& = D(P_{X_1 \tilde{X}_1 X_j \tilde{X}_j X_i Y} \| P_{X_1} P_{\tilde{X}_1} P_{X_j} P_{\tilde{X}_j} P_{X_i|\tilde{X}_1 \tilde{X}_j} W)
\end{aligned}$$

$$\stackrel{(b)}{\geq} D(P_{X_1 \tilde{X}_1 X_j \tilde{X}_j Y} \| P_{X_1} P_{\tilde{X}_1} P_{X_j} P_{\tilde{X}_j} \tilde{V}_1) \text{ where } \tilde{V}_1(y|x_1, \tilde{x}_1, x_j, \tilde{x}_j) = \sum_{x_i} P_{X_i | \tilde{X}_1 \tilde{X}_j} (x_i | \tilde{x}_1, \tilde{x}_j) W(y|x_1, x_j, x_i),$$

where (b) follows from the log sum inequality. From the given conditions, we know that the term on the LHS of (a) is no greater than 3η . Thus, $D(P_{X_1 \tilde{X}_1 X_j \tilde{X}_j Y} \| P_{X_1} P_{\tilde{X}_1} P_{X_j} P_{\tilde{X}_j} \tilde{V}_1) \leq 3\eta$. Using Pinsker's inequality, it follows that

$$\sum_{x_1, \tilde{x}_1, x_j, \tilde{x}_j, y} \left| P_{X_1 \tilde{X}_1 X_j \tilde{X}_j Y}(x_1, \tilde{x}_1, x_j, \tilde{x}_j, y) - P_{X_1}(x_1) P_{\tilde{X}_1}(\tilde{x}_1) P_{X_j}(x_j) P_{\tilde{X}_j}(\tilde{x}_j) \tilde{V}_1(y|x_1, \tilde{x}_1, x_j, \tilde{x}_j) \right| \leq c\sqrt{3\eta}, \quad (76)$$

where c is some positive constant. Following a similar line of argument, we can show that

$$\begin{aligned} 3\eta &\geq D(P_{\tilde{X}_1 \tilde{X}_j \tilde{X}_i Y} \| P_{\tilde{X}_1} \times P_{\tilde{X}_j} \times P_{\tilde{X}_i} \times W) + D(P_{X_1 X_j} \| P_{X_1} \times P_{X_j}) + I(\tilde{X}_1 \tilde{X}_j Y; X_1 X_j | \tilde{X}_i) \\ &\geq D(P_{X_1 \tilde{X}_1 X_j \tilde{X}_j Y} \| P_{X_1} P_{\tilde{X}_1} P_{X_j} P_{\tilde{X}_j} V_1) \text{ where } V_1(y|x_1, \tilde{x}_1, x_j, \tilde{x}_j) = \sum_{\tilde{x}_i} P_{\tilde{X}_i | X_1 X_j} (\tilde{x}_i | x_1, x_j) W(y|\tilde{x}_1, \tilde{x}_j, \tilde{x}_i) \end{aligned}$$

Using Pinsker's inequality, it follows that

$$\sum_{x_1, \tilde{x}_1, x_j, \tilde{x}_j, y} \left| P_{X_1 \tilde{X}_1 X_j \tilde{X}_j Y}(x_1, \tilde{x}_1, x_j, \tilde{x}_j, y) - P_{X_1}(x_1) P_{\tilde{X}_1}(\tilde{x}_1) P_{X_j}(x_j) P_{\tilde{X}_j}(\tilde{x}_j) V_1(y|x_1, \tilde{x}_1, x_j, \tilde{x}_j) \right| \leq c\sqrt{3\eta}. \quad (77)$$

From (76) and (77),

$$\sum_{x_1, \tilde{x}_1, x_j, \tilde{x}_j, y} P_{X_1}(x_1) P_{\tilde{X}_1}(\tilde{x}_1) P_{X_j}(x_j) P_{\tilde{X}_j}(\tilde{x}_j) \left| \tilde{V}_1(y|x_1, \tilde{x}_1, x_j, \tilde{x}_j) - V_1(y|x_1, \tilde{x}_1, x_j, \tilde{x}_j) \right| \leq 2c\sqrt{3\eta}.$$

This implies that

$$\max_{x_1, \tilde{x}_1, x_j, \tilde{x}_j, y} \left| \tilde{V}_1(y|x_1, \tilde{x}_1, x_j, \tilde{x}_j) - V_1(y|x_1, \tilde{x}_1, x_j, \tilde{x}_j) \right| \leq \frac{2c\sqrt{3\eta}}{\alpha^4}. \quad (78)$$

Similar to [10, (A.15) on page 748], since $W_{Y|X_1 X_2 X_3}$ is not $\mathcal{X}_1 \times \mathcal{X}_j$ -symmetrizable by \mathcal{X}_i (i.e., (5) does not hold for $(i, j, k) = (i, j, 1)$), we can show that for any pair of channels $P_{\tilde{X}_i | X_1 X_j}$ and $P_{X_i | \tilde{X}_1 \tilde{X}_j}$, there exists $\zeta_1 > 0$ such that

$$\max_{x_1, \tilde{x}_1, x_j, \tilde{x}_j, y} \left| \tilde{V}_1(y|x_1, \tilde{x}_1, x_j, \tilde{x}_j) - V_1(y|x_1, \tilde{x}_1, x_j, \tilde{x}_j) \right| \geq \zeta_1.$$

This contradicts (78) if $\eta < \frac{\zeta_1^2 \alpha^8}{12c^2}$.

We now analyze **Case 1(b)**.

$$\begin{aligned} &D(P_{X_1 X_j X_i Y} \| P_{X_1} \times P_{X_j} \times P_{X_i} \times W) + I(X_1 X_j Y; \tilde{X}_1 | X_i) \stackrel{(a)}{=} \\ &\sum_{x_1, x_j, x_i, y} P_{X_1 X_j X_i Y}(x_1, x_j, x_i, y) \log \frac{P_{X_1 X_j X_i Y}(x_1, x_j, x_i, y)}{P_{X_1}(x_1) P_{X_j}(x_j) P_{X_i}(x_i) W(y|x_1, x_j, x_i)} \\ &+ \sum_{x_1, \tilde{x}_1, x_j, x_i, y} P_{X_1 \tilde{X}_1 X_j X_i Y}(x_1, \tilde{x}_1, x_j, x_i, y) \log \frac{P_{X_1 \tilde{X}_1 X_j X_i Y}(x_1, \tilde{x}_1, x_j, x_i, y)}{P_{X_1 X_j Y | X_i}(x_1, x_j, y | x_i) P_{\tilde{X}_1 | X_i}(\tilde{x}_1 | x_i)} \\ &= \sum_{x_1, \tilde{x}_1, x_j, x_i, y} P_{X_1 \tilde{X}_1 X_j X_i Y}(x_1, \tilde{x}_1, x_j, x_i, y) \log \frac{P_{X_1 \tilde{X}_1 X_j X_i Y}(x_1, \tilde{x}_1, x_j, x_i, y)}{P_{X_1}(x_1) P_{\tilde{X}_1}(\tilde{x}_1) P_{X_j}(x_j) P_{X_i | \tilde{X}_1}(x_i | \tilde{x}_1) W(y|x_1, x_j, x_i)} \\ &= D(P_{X_1 \tilde{X}_1 X_j X_i Y} \| P_{X_1} P_{\tilde{X}_1} P_{X_j} P_{X_i | \tilde{X}_1} W) \end{aligned}$$

$$\stackrel{(b)}{\geq} D(P_{X_1 \tilde{X}_1 X_j Y} \| P_{X_1} P_{\tilde{X}_1} P_{X_j} \tilde{V}_2) \text{ where } \tilde{V}_2(y|x_1, \tilde{x}_1, x_j) = \sum_{x_i} P_{X_i | \tilde{X}_1}(x_i | \tilde{x}_1) W(y|x_1, x_j, x_i),$$

where (b) follows from the log sum inequality. From the given conditions, we know that the term on the LHS of (a) is no greater than 2η . Thus, $D(P_{X_1 \tilde{X}_1 X_j Y} \| P_{X_1} P_{\tilde{X}_1} P_{X_j} \tilde{V}_2) \leq 2\eta$. Using Pinsker's inequality, it follows that

$$\sum_{x_1, \tilde{x}_1, x_j, y} \left| P_{X_1 \tilde{X}_1 X_j Y}(x_1, \tilde{x}_1, x_j, y) - P_{X_1}(x_1) P_{\tilde{X}_1}(\tilde{x}_1) P_{X_j}(x_j) \tilde{V}_2(y|x_1, \tilde{x}_1, x_j) \right| \leq c\sqrt{2\eta}, \quad (79)$$

where c is some positive constant. Following a similar line of argument, we can show that

$$\begin{aligned} 2\eta &\geq D(P_{\tilde{X}_1 X_j \tilde{X}_i Y} \| P_{\tilde{X}_1} \times P_{X_j} \times P_{\tilde{X}_i} \times W) + I(\tilde{X}_1 X_j Y; X_1 | \tilde{X}_i) \\ &\geq D(P_{X_1 \tilde{X}_1 X_j Y} \| P_{X_1} P_{\tilde{X}_1} P_{X_j} V_2) \text{ where } V_2(y|x_1, \tilde{x}_1, x_j) = \sum_{\tilde{x}_i} P_{\tilde{X}_i | X_1}(\tilde{x}_i | x_1) W(y|\tilde{x}_1, x_j, \tilde{x}_i). \end{aligned}$$

Using Pinsker's inequality, it follows that

$$\sum_{x_1, \tilde{x}_1, x_j, y} \left| P_{X_1 \tilde{X}_1 X_j Y}(x_1, \tilde{x}_1, x_j, y) - P_{X_1}(x_1) P_{\tilde{X}_1}(\tilde{x}_1) P_{X_j}(x_j) V_2(y|x_1, \tilde{x}_1, x_j) \right| \leq c\sqrt{3\eta}. \quad (80)$$

From (79) and (80),

$$\sum_{x_1, \tilde{x}_1, x_j, y} P_{X_1}(x_1) P_{\tilde{X}_1}(\tilde{x}_1) P_{X_j}(x_j) \left| \tilde{V}_2(y|x_1, \tilde{x}_1, x_j) - V_2(y|x_1, \tilde{x}_1, x_j) \right| \leq 2c\sqrt{3\eta}.$$

This implies that

$$\max_{x_1, \tilde{x}_1, x_j, y} \left| \tilde{V}_2(y|x_1, \tilde{x}_1, x_j) - V_2(y|x_1, \tilde{x}_1, x_j) \right| \leq \frac{2c\sqrt{2\eta}}{\alpha^4}. \quad (81)$$

Similar to [10, (A.5) on page 747], since $W_{Y|X_1 X_2 X_3}$ is not $\mathcal{X}_1 | \mathcal{X}_j$ -symmetrizable by \mathcal{X}_i (i.e., (6) does not hold for $(i, j, k) = (i, j, 1)$), we can show that for any pair for channels $P_{\tilde{X}_i | X_1}$ and $P_{X_i | \tilde{X}_1}$, there exists $\zeta_2 > 0$ such that

$$\max_{x_1, \tilde{x}_1, x_j, y} \left| \tilde{V}_2(y|x_1, \tilde{x}_1, x_j) - V_2(y|x_1, \tilde{x}_1, x_j) \right| \geq \zeta_2.$$

This contradicts (81) if $\eta < \frac{\zeta_2^2 \alpha^8}{8c^2}$.

We now analyse **Case 2**.

$$\begin{aligned} &D(P_{X_1 X_j X_i Y} \| P_{X_1} \times P_{X_j} \times P_{X_i} \times W) + D(P_{\tilde{X}_1, \tilde{X}_i} \| P_{\tilde{X}_1} \times P_{\tilde{X}_i}) + I(X_1 X_j Y; \tilde{X}_1 \tilde{X}_i | X_i) \stackrel{(a)}{=} \\ &\sum_{x_1, x_j, x_i, y} P_{X_1 X_j X_i Y}(x_1, x_j, x_i, y) \log \frac{P_{X_1 X_j X_i Y}(x_1, x_j, x_i, y)}{P_{X_1}(x_1) P_{X_j}(x_j) P_{X_i}(x_i) W(y|x_1, x_j, x_i)} + \sum_{\tilde{x}_1, \tilde{x}_i} P_{\tilde{X}_1 \tilde{X}_i}(\tilde{x}_1, \tilde{x}_i) \log \frac{P_{\tilde{X}_1 \tilde{X}_i}(\tilde{x}_1, \tilde{x}_i)}{P_{\tilde{X}_1}(\tilde{x}_1) P_{\tilde{X}_i}(\tilde{x}_i)} \\ &+ \sum_{x_1, \tilde{x}_1, x_j, x_i, \tilde{x}_i, y} P_{X_1 \tilde{X}_1 X_j X_i \tilde{X}_i Y}(x_1, \tilde{x}_1, x_j, x_i, \tilde{x}_i, y) \log \frac{P_{X_1 \tilde{X}_1 X_j X_i \tilde{X}_i Y | X_i}(x_1, \tilde{x}_1, x_j, \tilde{x}_i, y | x_i)}{P_{\tilde{X}_1 \tilde{X}_i | X_i}(\tilde{x}_1, \tilde{x}_i | x_i) P_{X_1 X_j Y | X_i}(x_1, x_j, y | x_i)} \\ &= \sum_{x_1, \tilde{x}_1, x_j, x_i, \tilde{x}_i, y} P_{X_1 \tilde{X}_1 X_j X_i \tilde{X}_i Y}(x_1, \tilde{x}_1, x_j, x_i, \tilde{x}_i, y) \log \frac{P_{X_1 \tilde{X}_1 X_j X_i \tilde{X}_i Y}(x_1, \tilde{x}_1, x_j, x_i, \tilde{x}_i, y)}{P_{X_1}(x_1) P_{\tilde{X}_1}(\tilde{x}_1) P_{X_j}(x_j) P_{\tilde{X}_i}(\tilde{x}_i) P_{X_i | \tilde{X}_1 \tilde{X}_i}(x_i | \tilde{x}_1, \tilde{x}_i) W(y|x_1, x_j, x_i)} \\ &= D(P_{X_1 \tilde{X}_1 X_j X_i \tilde{X}_i Y} \| P_{X_1} P_{\tilde{X}_1} P_{X_j} P_{\tilde{X}_i} P_{X_i | \tilde{X}_1 \tilde{X}_i} W) \end{aligned}$$

$$\stackrel{(b)}{\geq} D(P_{X_1 \tilde{X}_1 X_j \tilde{X}_i Y} \| P_{X_1} P_{\tilde{X}_1} P_{X_j} P_{\tilde{X}_i} \tilde{V}_3) \text{ where } \tilde{V}_3(y|x_1, \tilde{x}_1, x_j, \tilde{x}_i) = \sum_{x_i} P_{X_i | \tilde{X}_1 \tilde{X}_i} (x_i | \tilde{x}_1, \tilde{x}_i) W(y|x_1, x_j, x_i),$$

where (b) follows from the log sum inequality. From the given conditions, we know that the term on the LHS of (a) is no greater than 3η . Thus, $D(P_{X_1 \tilde{X}_1 X_j \tilde{X}_i Y} \| P_{X_1} P_{\tilde{X}_1} P_{X_j} P_{\tilde{X}_i} \tilde{V}_3) \leq 3\eta$. Using Pinsker's inequality, it follows that

$$\sum_{x_1, \tilde{x}_1, x_j, \tilde{x}_i, y} \left| P_{X_1 \tilde{X}_1 X_j \tilde{X}_i Y} (x_1, \tilde{x}_1, x_j, \tilde{x}_i, y) - P_{X_1}(x_1) P_{\tilde{X}_1}(\tilde{x}_1) P_{X_j}(x_j) P_{\tilde{X}_i}(\tilde{x}_i) \tilde{V}_3(y|x_1, \tilde{x}_1, x_j, \tilde{x}_i) \right| \leq c\sqrt{3\eta} \quad (82)$$

for some constant $c > 0$. Following a similar line of argument,

$$\begin{aligned} & D(P_{\tilde{X}_1 \tilde{X}_j \tilde{X}_i Y} \| P_{\tilde{X}_1} \times P_{\tilde{X}_j} \times P_{\tilde{X}_i} \times W) + D(P_{X_1 X_j} \| P_{X_1} \times P_{X_j}) + I(\tilde{X}_1 \tilde{X}_i Y; X_1 X_j | \tilde{X}_j) \stackrel{(a)}{=} \\ & \sum_{\tilde{x}_1, \tilde{x}_j, \tilde{x}_i, y} P_{\tilde{X}_1 \tilde{X}_j \tilde{X}_i Y}(\tilde{x}_1, \tilde{x}_j, \tilde{x}_i, y) \log \frac{P_{\tilde{X}_1 \tilde{X}_j \tilde{X}_i Y}(\tilde{x}_1, \tilde{x}_j, \tilde{x}_i, y)}{P_{\tilde{X}_1}(\tilde{x}_1) P_{\tilde{X}_j}(\tilde{x}_j) P_{\tilde{X}_i}(\tilde{x}_i) W(y|\tilde{x}_1, \tilde{x}_j, \tilde{x}_i)} + \sum_{x_1, x_j} P_{X_1 X_j}(x_1, x_j) \log \frac{P_{X_1 X_j}(x_1, x_j)}{P_{X_1}(x_1) P_{X_j}(x_j)} \\ & + \sum_{x_1, \tilde{x}_1, x_j, \tilde{x}_j, \tilde{x}_i, y} P_{X_1 \tilde{X}_1 X_j \tilde{X}_j \tilde{X}_i Y}(x_1, \tilde{x}_1, x_j, \tilde{x}_j, \tilde{x}_i, y) \log \frac{P_{X_1 \tilde{X}_1 X_j \tilde{X}_j \tilde{X}_i Y}(x_1, \tilde{x}_1, x_j, \tilde{x}_j, \tilde{x}_i, y | \tilde{x}_j)}{P_{\tilde{X}_1 \tilde{X}_i Y | \tilde{X}_j}(\tilde{x}_1, \tilde{x}_i, y | \tilde{x}_j) P_{X_1 X_j | \tilde{X}_j}(x_1, x_j | \tilde{x}_j)} \\ & = \sum_{x_1, \tilde{x}_1, x_j, \tilde{x}_j, \tilde{x}_i, y} P_{X_1 \tilde{X}_1 X_j \tilde{X}_j \tilde{X}_i Y}(x_1, \tilde{x}_1, x_j, \tilde{x}_j, \tilde{x}_i, y) \log \frac{P_{X_1 \tilde{X}_1 X_j \tilde{X}_j \tilde{X}_i Y}(x_1, \tilde{x}_1, x_j, \tilde{x}_j, \tilde{x}_i, y)}{P_{X_1}(x_1) P_{\tilde{X}_1}(\tilde{x}_1) P_{X_j}(x_j) P_{\tilde{X}_i}(\tilde{x}_i) P_{\tilde{X}_j | X_1 X_j}(\tilde{x}_j | x_1, x_j) W(y|\tilde{x}_1, \tilde{x}_j, \tilde{x}_i)} \\ & = D(P_{X_1 \tilde{X}_1 X_j \tilde{X}_j \tilde{X}_i Y} \| P_{X_1} P_{\tilde{X}_1} P_{X_j} P_{\tilde{X}_j} P_{\tilde{X}_i} |_{X_1 X_j} W) \\ & \geq D(P_{X_1 \tilde{X}_1 X_j \tilde{X}_i Y} \| P_{X_1} P_{\tilde{X}_1} P_{X_j} P_{\tilde{X}_i} V_3) \text{ where } V_3(y|x_1, \tilde{x}_1, x_j, \tilde{x}_i) = \sum_{\tilde{x}_j} P_{\tilde{X}_j | X_1 X_j}(\tilde{x}_j | x_1, x_j) W(y|\tilde{x}_1, \tilde{x}_j, \tilde{x}_i). \end{aligned}$$

From the given conditions, the term on the left of (a) is no larger than 3η . Thus, $D(P_{X_1 \tilde{X}_1 X_j \tilde{X}_i Y} \| P_{X_1} P_{\tilde{X}_1} P_{X_j} P_{\tilde{X}_i} V_3) \leq 3\eta$.

Using Pinsker's inequality, it follows that

$$\sum_{x_1, \tilde{x}_1, x_j, \tilde{x}_i, y} \left| P_{X_1 \tilde{X}_1 X_j \tilde{X}_i Y}(x_1, \tilde{x}_1, x_j, \tilde{x}_i, y) - P_{X_1}(x_1) P_{\tilde{X}_1}(\tilde{x}_1) P_{X_j}(x_j) P_{\tilde{X}_i}(\tilde{x}_i) V_3(y|x_1, \tilde{x}_1, x_j, \tilde{x}_i) \right| \leq c\sqrt{3\eta}. \quad (83)$$

From (82) and (83),

$$\sum_{x_1, \tilde{x}_1, x_j, \tilde{x}_j, y} P_{X_1}(x_1) P_{\tilde{X}_1}(\tilde{x}_1) P_{X_j}(x_j) P_{\tilde{X}_i}(\tilde{x}_i) \left| \tilde{V}_3(y|x_1, \tilde{x}_1, x_j, \tilde{x}_i) - V_3(y|x_1, \tilde{x}_1, x_j, \tilde{x}_i) \right| \leq 2c\sqrt{3\eta}. \quad (84)$$

This implies that

$$\max_{x_1, \tilde{x}_1, x_j, \tilde{x}_j, y} \left| \tilde{V}_3(y|x_1, \tilde{x}_1, x_j, \tilde{x}_i) - V_3(y|x_1, \tilde{x}_1, x_j, \tilde{x}_i) \right| \leq \frac{2c\sqrt{3\eta}}{\alpha^4}. \quad (85)$$

Since $W_{Y|X_1 X_2 X_3}$ is not \mathcal{X}_1 -symmetrizable by $\mathcal{X}_j / \mathcal{X}_i$ (i.e., (7) does not hold for $(i, j, k) = (i, j, 1)$), for any pair of channels $P_{X_i | \tilde{X}_1 \tilde{X}_i}$ and $P_{\tilde{X}_j | X_1 X_j}$, there exists $\zeta_3 > 0$, such that

$$\max_{x_1, \tilde{x}_1, x_j, \tilde{x}_j, y} \left| \tilde{V}_3(y|x_1, \tilde{x}_1, x_j, \tilde{x}_i) - V_3(y|x_1, \tilde{x}_1, x_j, \tilde{x}_i) \right| \geq \zeta_3.$$

This contradicts (85) if $\eta < \frac{\zeta_3^2 \alpha^8}{12c^2}$. Let $\zeta \stackrel{\text{def}}{=} \min \{\zeta_1, \zeta_2, \zeta_3\}$, any η satisfying $0 < \eta < \frac{\zeta^2 \alpha^8}{12c^2}$ ensures disjoint decoding regions. \square

B Proof of Lemma 4

To prove Lemma 4, we will first define some terminology and prove the concentration result in Lemma 11. This will be used to prove Lemma 13, which implies Lemma 4 as a corollary (see Corollary 14).

For random variables Z_1, Z_2, \dots, Z_m , let $C(Z_1; Z_2; \dots; Z_m)$ denote the total correlation of the random variables Z_1, Z_2, \dots, Z_m which is given by

$$C(Z_1; Z_2; \dots; Z_m) := \sum_{i=1}^m H(Z_i) - H(Z_1, Z_2, \dots, Z_m). \quad (86)$$

Note that $C(Z_1; Z_2; \dots; Z_m)$ can also be written as

$$\sum_{i=2}^m I(Z_i; Z^{i-1}).$$

Suppose \mathbb{R}_+ denotes the set of positive real numbers. Let $k \in \{1, 2, \dots\}$. Consider random variables U_1, U_2, \dots, U_k, V and a set $\mathcal{S} \subseteq [1 : k]$ given by $\mathcal{S} = \{\alpha_1, \alpha_2, \dots, \alpha_{|\mathcal{S}|}\}$. Let $\mathcal{S}^c = [1 : k] \setminus \mathcal{S}$ be denoted by $\mathcal{S}^c = \{\beta_1, \beta_2, \dots, \beta_{k-|\mathcal{S}|}\}$. We define $g_{U_1, U_2, \dots, U_k, V}^{\mathcal{S}} : \mathbb{R}_+^k \rightarrow \mathbb{R}_+$ as

$$g_{U_1, U_2, \dots, U_k, V}^{\mathcal{S}}(R_1, R_2, \dots, R_k) = \left(\sum_{i \in \mathcal{S}} R_i \right) - C(U_{\alpha_1}; U_{\alpha_2}; \dots; U_{\alpha_{|\mathcal{S}|}}; (U_{\beta_1}, U_{\beta_2}, \dots, U_{\beta_{k-|\mathcal{S}|}}, V)) \quad (87)$$

Note that the tuple $(U_{\beta_1}, U_{\beta_2}, \dots, U_{\beta_{k-|\mathcal{S}|}}, V)$ is treated as a single random variable. Thus, when $|\mathcal{S}| = 0$,

$$g_{U_1, U_2, \dots, U_k, V}^{\mathcal{S}}(R_1, R_2, \dots, R_k) = 0.$$

For a positive integer b , let \mathcal{S}_b denote the symmetric group of degree b , i.e., it contains the permutations of $\{1, 2, \dots, b\}$. For a permutation $\sigma \in \mathcal{S}_b$, let $\sigma(i)$, $i \in \{1, 2, \dots, b\}$ denote the image of i under σ . Let \mathcal{A} be a set. For a b -length tuple $(\alpha_1, \dots, \alpha_b)$ consisting of distinct elements of \mathcal{A} , let

$$\mathcal{H}_{(\alpha_1, \dots, \alpha_b)} = \left\{ a \in (\{\alpha_1, \dots, \alpha_b\} \cup \{*\})^b : \exists \sigma \in \mathcal{S}_b \text{ such that for all } j \in [1 : b] \text{ if } a_j \neq * \text{ then } a_j = \alpha_{\sigma(j)} \right\},$$

where a_j represents the j^{th} element of the tuple a . For $a \in \mathcal{H}_{(\alpha_1, \dots, \alpha_b)}$, let $|a| = |\{i : a_i \neq *\}|$. For a tuple $(\gamma_1, \dots, \gamma_b)$ consisting of distinct elements of \mathcal{A} , we say that $a \in \mathcal{H}_{(\alpha_1, \dots, \alpha_b)}$ and $(\gamma_1, \dots, \gamma_b)$ are $(\alpha_1, \dots, \alpha_b)$ -compatible (denoted by $(\gamma_1, \dots, \gamma_b) \sim [a, (\alpha_1, \dots, \alpha_b)]$, if for all $l \in \{1, \dots, b\}$,

$$\gamma_l = \begin{cases} a_l, & \text{if } a_l \neq *, \\ \gamma_l \in \mathcal{I} \setminus \{\alpha_1, \dots, \alpha_b\}, & \text{otherwise.} \end{cases}$$

For example, for $\mathcal{A} = \{1, 2, \dots, 9\}$ and a 5-length tuple $(1, 2, 3, 4, 5)$, $(1, 2, *, *, 4) \in \mathcal{H}_{(1, 2, 3, 4, 5)}$, $|(1, 2, *, *, 4)| = 3$ and the tuple $(1, 2, 6, 8, 4) \sim [(1, 2, *, *, 4), (1, 2, 3, 4, 5)]$.

Lemma 11. For an index set \mathcal{I} , let $\{Y_i : i \in \mathcal{I}\}$ be a set of independent random variables. Let β be a positive integer. Let $\mathcal{J} \subseteq \mathcal{I}^\beta$ be a set of β length tuples consisting of distinct elements from \mathcal{I} . For $(i_1, \dots, i_\beta) \in \mathcal{J}$, let $V_{(i_1, \dots, i_\beta)}$ be a binary random variable which is a function of $Y_{i_1}, \dots, Y_{i_\beta}$. Suppose $U = \sum_{(i_1, \dots, i_\beta) \in \mathcal{J}} V_{(i_1, \dots, i_\beta)}$. Let

$$E \geq \max \left\{ \max_{(i_1, \dots, i_\beta) \in \mathcal{J}} \max_{\substack{a \in \mathcal{H}_{(i_1, \dots, i_\beta)} \\ 1 \leq |a| \leq \beta - 1}} \mathbb{E} \left[\sum_{\substack{(j_1, \dots, j_\beta) \in \mathcal{J} \\ (j_1, \dots, j_\beta) \sim [a, (i_1, \dots, i_\beta)]}} V_{(j_1, \dots, j_\beta)} \middle| (Y_{i_1}, \dots, Y_{i_\beta}) = (y_{i_1}, \dots, y_{i_\beta}) \right], \mathbb{E}[U] \right\},$$

For $\gamma > 0$, $\nu > 1$ if there exists $\delta_1, \delta_2, \dots, \delta_\beta > 1$ such that for all $i \in [1 : \beta]$, $\frac{1}{(2\beta)^\beta} \left(\frac{\delta_{i-1}-1}{2\gamma} E - \beta! \right) > \delta_i E$ for $\delta_0 := \nu$, then

$$\mathbb{P}(U \geq \nu E) \leq (|\mathcal{I}| \beta + 1)^{\beta^2} e^{-\gamma/3}. \quad (88)$$

Proof. For $(i_1, \dots, i_\beta) \in \mathcal{J}$, let $\tilde{U}_{(i_1, \dots, i_\beta)} = \sum_{(j_1, \dots, j_\beta) \in \mathcal{J} : \{j_1, \dots, j_\beta\} \cap \{i_1, \dots, i_\beta\} \neq \emptyset} V_{(j_1, \dots, j_\beta)}$. To show (88), we will first show that

$$\mathbb{P}(U \geq \nu E) \leq e^{-\gamma/3} + \sum_{(i_1, \dots, i_\beta) \in \mathcal{J}} \mathbb{P} \left(\tilde{U}_{(i_1, \dots, i_\beta)} > \frac{(\nu-1)E}{2\gamma} \right) \quad (89)$$

using [23, Theorem 2.1].

Lemma 12. [23, Theorem 2.1] Suppose that $Y_\alpha, \alpha \in \mathcal{A}$, is a finite family of non-negative random variables and that \sim is a symmetric relation on the index set \mathcal{A} such that each Y_α is independent of $\{Y_\beta : \beta \sim \alpha\}$; in other words, the pairs (α, β) with $\alpha \sim \beta$ define the edge set of a (weak) dependency graph for the variables Y_α . Let $X := \sum_\alpha Y_\alpha$ and $\mu := \mathbb{E}X = \sum_\alpha \mathbb{E}Y_\alpha$. Let further, for $\alpha \in \mathcal{A}$, $\tilde{X}_\alpha := \sum_{\beta \sim \alpha} Y_\beta$. If $t \geq \mu > 0$, then for every real $r > 0$,

$$\mathbb{P}(X > \mu + t) \leq e^{-r/3} + \sum_{\alpha \in \mathcal{A}} \mathbb{P} \left(\tilde{X}_\alpha > \frac{t}{2r} \right).$$

In order to obtain (89) from [23, Theorem 2.1], we use \mathcal{J} in place of \mathcal{A} and $V_{(i_1, \dots, i_\beta)}$ in place of Y_α . We note that every $(i_1, \dots, i_\beta), (j_1, \dots, j_\beta) \in \mathcal{J}$ such that $\{i_1, \dots, i_\beta\} \cap \{j_1, \dots, j_\beta\} \neq \emptyset$, $(i_1, \dots, i_\beta) \sim (j_1, \dots, j_\beta)$ as per the symmetric relation given in Lemma 12. Thus, the definitions of $\tilde{U}_{(i_1, \dots, i_\beta)}$ and \tilde{X}_α are consistent. We upper bound the LHS of (89) as follows:

$$\begin{aligned} \mathbb{P}(X \geq \nu E) &= \mathbb{P}(X - \mathbb{E}[X] \geq \nu E - \mathbb{E}[X]) \\ &\leq \mathbb{P}(X - \mathbb{E}[X] \geq \nu E - E) \\ &= \mathbb{P}(X - \mathbb{E}[X] \geq (\nu - 1)E) \end{aligned}$$

Theorem [23, Theorem 2.1] is applied on $\mathbb{P}(X \geq \mathbb{E}[X] + (\nu - 1)E)$ with $(\nu - 1)E$ as t and γ as r .

Now, we will show (88). We will use **strong induction on β** . When $\beta = 1$, (89) implies $\mathbb{P}(U \geq \nu E) \leq e^{-\gamma/3}$. This is because for any 1-length tuple $(i) \in \mathcal{J}$, $\tilde{U}_{(i)} = V_{(i)}$, which, being a binary random variable, is at most 1. However, $\frac{1}{(2\beta)^\beta} \left(\frac{\nu-1}{2\gamma} E - \beta! \right) > \delta_1 E \geq 0$ implies that for $\beta = 1$, $\frac{1}{2} \left(\frac{\nu-1}{2\gamma} E - 1 \right) > 0$. Therefore, $\frac{\nu-1}{2\gamma} E > 1$ and the second term on the RHS of (89) is zero. Thus, (88) holds for $\beta = 1$.

Now, for the **induction hypothesis**, consider any $\beta' \leq k$ for some positive integer k . For an index set \mathcal{I}' , let $\{Y'_i : i \in \mathcal{I}'\}$ be a set of independent random variables. Let $\mathcal{J}' \subseteq \mathcal{I}'^{\beta'}$ be a set of β' -length tuples consisting of distinct elements from \mathcal{I}' . For $(i_1, \dots, i_{\beta'}) \in \mathcal{J}'$, let $V'_{(i_1, \dots, i_{\beta'})}$ be a binary random variable which is a function of $Y'_{i_1}, Y'_{i_2}, \dots, Y'_{i_{\beta'}}$. Suppose $U' = \sum_{(i_1, \dots, i_{\beta'}) \in \mathcal{J}'} V'_{(i_1, \dots, i_{\beta'})}$.

Let

$$E' \geq \max \left\{ \max_{(i_1, \dots, i_{\beta'}) \in \mathcal{J}'} \max_{\substack{a \in \mathcal{H}_{(i_1, \dots, i_{\beta'})} \\ 1 \leq |a| \leq \beta' - 1}} \mathbb{E} \left[\sum_{\substack{(j_1, \dots, j_{\beta'}) \in \mathcal{J}': \\ (j_1, \dots, j_{\beta'}) \sim [a, (i_1, \dots, i_{\beta'})]}} V'_{(j_1, \dots, j_{\beta'})} \middle| (Y'_{i_1}, \dots, Y'_{i_{\beta'}}) = (y'_{i_1}, \dots, y'_{i_{\beta'}}) \right], \mathbb{E}[U'] \right\},$$

For $\gamma' > 0$, $\nu' > 1$, if there exists $\delta'_1, \delta'_2, \dots, \delta'_{\beta'} > 1$ such that for all $i \in [1 : \beta']$, $\frac{1}{(2\beta')^{\beta'}} \left(\frac{\delta'_{i-1}-1}{2\gamma'} E' - \beta'! \right) > \delta'_i E'$ for $\delta'_0 := \nu'$, then

$$\mathbb{P}(U' \geq \nu' E') \leq (|\mathcal{I}'| \beta' + 1)^{\beta'^2} e^{-\gamma'/3}.$$

Now, for $\beta = k + 1$ and any γ, ν , and E and random variables satisfying the conditions in Lemma 11, (89) gives

$$\mathbb{P}(U \geq \nu E) \leq e^{-\gamma/3} + \sum_{(i_1, \dots, i_{k+1}) \in \mathcal{J}} \mathbb{P} \left(\tilde{U}_{(i_1, \dots, i_{k+1})} > \frac{(\nu - 1)E}{2\gamma} \right).$$

For $(i_1, \dots, i_{k+1}) \in \mathcal{J}$, and any realization $(y_{i_1}, \dots, y_{i_{k+1}})$ of $(Y_{i_1}, \dots, Y_{i_{k+1}})$,

$$\begin{aligned} & \mathbb{P} \left(\tilde{U}_{(i_1, \dots, i_{k+1})} > \frac{(\nu - 1)E}{2\gamma} \mid (Y_{i_1}, \dots, Y_{i_{k+1}}) = (y_{i_1}, \dots, y_{i_{k+1}}) \right) \\ & \leq \mathbb{P} \left(\sum_{\sigma \in \mathcal{S}_{k+1}} V_{\sigma(i_1, \dots, i_{k+1})} + \sum_{\substack{a \in \mathcal{H}_{(i_1, \dots, i_{k+1})} \\ 1 \leq |a| \leq k}} \sum_{\substack{(j_1, \dots, j_{k+1}) \in \mathcal{J}: \\ (j_1, \dots, j_{k+1}) \sim [a, (i_1, \dots, i_{k+1})]}} V_{(j_1, \dots, j_{k+1})} > \frac{(\nu - 1)E}{2\gamma} \mid \right. \\ & \qquad \qquad \qquad \left. (Y_{i_1}, \dots, Y_{i_{k+1}}) = (y_{i_1}, \dots, y_{i_{k+1}}) \right) \\ & = \mathbb{P} \left(\sum_{\substack{a \in \mathcal{H}_{(i_1, \dots, i_{k+1})} \\ 1 \leq |a| \leq k}} \sum_{\substack{(j_1, \dots, j_{k+1}) \in \mathcal{J}: \\ (j_1, \dots, j_{k+1}) \sim [a, (i_1, \dots, i_{k+1})]}} V_{(j_1, \dots, j_{k+1})} > \frac{(\nu - 1)E}{2\gamma} - \sum_{\sigma \in \mathcal{S}_{k+1}} V_{\sigma(i_1, \dots, i_{k+1})} \mid \right. \\ & \qquad \qquad \qquad \left. (Y_{i_1}, \dots, Y_{i_{k+1}}) = (y_{i_1}, \dots, y_{i_{k+1}}) \right) \\ & \stackrel{(a)}{\leq} \mathbb{P} \left(\sum_{\substack{a \in \mathcal{H}_{(i_1, \dots, i_{k+1})} \\ 1 \leq |a| \leq k}} \sum_{\substack{(j_1, \dots, j_{k+1}) \in \mathcal{J}: \\ (j_1, \dots, j_{k+1}) \sim [a, (i_1, \dots, i_{k+1})]}} V_{(j_1, \dots, j_{k+1})} > \frac{(\nu - 1)E}{2\gamma} - |\mathcal{S}_{k+1}| \mid (Y_{i_1}, \dots, Y_{i_{k+1}}) = (y_{i_1}, \dots, y_{i_{k+1}}) \right) \\ & \stackrel{(b)}{\leq} \mathbb{P} \left(\bigcup_{\substack{a \in \mathcal{H}_{(i_1, \dots, i_{k+1})} \\ 1 \leq |a| \leq k}} \left(\sum_{\substack{(j_1, \dots, j_{k+1}) \in \mathcal{J}: \\ (j_1, \dots, j_{k+1}) \sim [a, (i_1, \dots, i_{k+1})]}} V_{(j_1, \dots, j_{k+1})} > \frac{1}{|\mathcal{H}_{(i_1, \dots, i_{k+1})}| - 1 - (k+1)!} \left(\frac{(\nu - 1)E}{2\gamma} - (k+1)! \right) \right) \mid \right. \\ & \qquad \qquad \qquad \left. (Y_{i_1}, \dots, Y_{i_{k+1}}) = (y_{i_1}, \dots, y_{i_{k+1}}) \right) \\ & \leq \mathbb{P} \left(\bigcup_{\substack{a \in \mathcal{H}_{(i_1, \dots, i_{k+1})} \\ 1 \leq |a| \leq k}} \left(\sum_{\substack{(j_1, \dots, j_{k+1}) \in \mathcal{J}: \\ (j_1, \dots, j_{k+1}) \sim [a, (i_1, \dots, i_{k+1})]}} V_{(j_1, \dots, j_{k+1})} > \frac{1}{|\mathcal{H}_{(i_1, \dots, i_{k+1})}|} \left(\frac{(\nu - 1)E}{2\gamma} - (k+1)! \right) \right) \mid \right. \\ & \qquad \qquad \qquad \left. (Y_{i_1}, \dots, Y_{i_{k+1}}) = (y_{i_1}, \dots, y_{i_{k+1}}) \right) \end{aligned}$$

$$\begin{aligned}
&\stackrel{(c)}{\leq} \sum_{\substack{a \in \mathcal{H}(i_1, \dots, i_{k+1}) \\ 1 \leq |a| \leq k}} \mathbb{P} \left(\sum_{\substack{(j_1, \dots, j_{k+1}) \in \mathcal{J}: \\ (j_1, \dots, j_{k+1}) \sim [a, (i_1, \dots, i_{k+1})]}} V_{(j_1, \dots, j_{k+1})} > \frac{1}{(2(k+1))^{k+1}} \left(\frac{(\nu-1)E}{2\gamma} - (k+1)! \right) \middle| \right. \\
&\qquad \qquad \qquad \left. (Y_{i_1}, \dots, Y_{i_{k+1}}) = (y_{i_1}, \dots, y_{i_{k+1}}) \right) \\
&\stackrel{(d)}{\leq} \sum_{\substack{a \in \mathcal{H}(i_1, \dots, i_{k+1}) \\ 1 \leq |a| \leq k}} \mathbb{P} \left(\sum_{\substack{(j_1, \dots, j_{k+1}) \in \mathcal{J}: \\ (j_1, \dots, j_{k+1}) \sim [a, (i_1, \dots, i_{k+1})]}} V_{(j_1, \dots, j_{k+1})} > \frac{1}{(2(k+1))^{k+1}} \left(\frac{(\nu-1)E}{2\gamma} - (k+1)!E \right) \middle| \right. \\
&\qquad \qquad \qquad \left. (Y_{i_1}, \dots, Y_{i_{k+1}}) = (y_{i_1}, \dots, y_{i_{k+1}}) \right) \\
&\stackrel{(e)}{\leq} \sum_{\substack{a \in \mathcal{H}(i_1, \dots, i_{k+1}) \\ 1 \leq |a| \leq k}} \mathbb{P} \left(\sum_{\substack{(j_1, \dots, j_{k+1}) \in \mathcal{J}: \\ (j_1, \dots, j_{k+1}) \sim [a, (i_1, \dots, i_{k+1})]}} V_{(j_1, \dots, j_{k+1})} > \delta_1 E \middle| (Y_{i_1}, \dots, Y_{i_{k+1}}) = (y_{i_1}, \dots, y_{i_{k+1}}) \right). \tag{90}
\end{aligned}$$

Here, (a) holds because $\sum_{\sigma \in \mathcal{S}} V_{\sigma(i_1, \dots, i_{k+1})}$, being a sum of binary random variables, takes the maximum value $|\mathcal{S}|$ which is $(k+1)!$. The equality (b) holds because $\mathbb{P}\left(\sum_{1 \leq i \leq t} A_i > c\right) \leq \mathbb{P}\left(\cup_{1 \leq i \leq t} \{A_i > c/t\}\right)$ for any integer t , real number c and random variables A_1, \dots, A_t . The inequality (c) uses union bound and the fact that $|\mathcal{H}(i_1, \dots, i_{k+1})| \leq (\# \text{ of subsets of } \{i_1, \dots, i_{k+1}\}) \times |\mathcal{S}_{k+1}|$. Thus, $|\mathcal{H}(i_1, \dots, i_{k+1})| \leq 2^{k+1}(k+1)! \leq (2(k+1))^{k+1}$. Inequality (d) holds because $E \geq 1$ and (e) follows from the conditions on ν, γ and $\beta = k+1$ in the statement of Lemma 11.

Fix $(i_1, \dots, i_{k+1}) \in \mathcal{J}$, $(Y_{i_1}, \dots, Y_{i_{k+1}}) = (y_{i_1}, \dots, y_{i_{k+1}})$ and $a \in \mathcal{H}(i_1, \dots, i_{k+1})$ such that $|a| = l$ where $l \in [1 : k]$. We will use induction hypothesis at this stage. To use induction hypothesis, choose $\nu' = \delta_1$, $\gamma' = \gamma$, $E' = E$, $\beta' = k+1-l$ and $\mathcal{I}' = \mathcal{I} \setminus \{i_1, \dots, i_{k+1}\}$. The set of random variables $\{Y'_i : i \in \mathcal{I}'\}$ is given by $Y'_i = Y_i, \forall i \in \mathcal{I}'$. For $i \in [1 : k+1]$, let $|a_1^{i-1}| = |\{j \in [1 : i-1] : a_j \neq *\}|$. The set \mathcal{J}' consists of $(k+1-l)$ -length tuples of distinct elements from \mathcal{I}' such that for every $(j_1, \dots, j_{k+1-l}) \in \mathcal{J}'$, there exists $(m_1, \dots, m_{k+1}) \in \mathcal{J}$ such that $m_l = a_l$ if $a_l \neq *$. Else, $m_l = j_{l-|a_1^{l-1}|}$. For such $(m_1, \dots, m_{k+1}) \in \mathcal{J}$ and (j_1, \dots, j_{k+1-l}) , we will say that $(j_1, \dots, j_{k+1-l}) + a = (m_1, \dots, m_{k+1})$. Thus, for every $(m_1, \dots, m_{k+1}) \in \mathcal{J}$ such that $(m_1, \dots, m_{k+1}) \sim [a, (i_1, \dots, i_{k+1})]$, there exists a unique $(j_1, \dots, j_{k+1-l}) \in \mathcal{J}'$ with $(j_1, \dots, j_{k+1-l}) + a = (m_1, \dots, m_{k+1})$.

For $(j_1, \dots, j_{k+1-l}) \in \mathcal{J}'$, the binary random variable $V'_{(j_1, \dots, j_{k+1-l})}$ is the random variable $V_{(m_1, \dots, m_{k+1})}$ where $(m_1, \dots, m_{k+1}) = (j_1, \dots, j_{k+1-l}) + a$ and the random variables $(Y_{i_1}, \dots, Y_{i_{k+1}})$ are fixed to $(y_{i_1}, \dots, y_{i_{k+1}})$. For $U' = \sum_{(j_1, \dots, j_{k+1-l}) \in \mathcal{J}'} V'_{(j_1, \dots, j_{k+1-l})}$, we will use induction hypothesis on $\mathbb{P}(U' \geq \delta_1 E)$.

$$\begin{aligned}
&\mathbb{P}(U' \geq \delta_1 E) \\
&= \mathbb{P} \left(\sum_{(j_1, \dots, j_{k+1-l}) \in \mathcal{J}'} V'_{(j_1, \dots, j_{k+1-l})} > \delta_1 E \right) \\
&= \mathbb{P} \left(\sum_{\substack{(m_1, \dots, m_{k+1}) \in \mathcal{J}: \\ (m_1, \dots, m_{k+1}) \sim [a, (i_1, \dots, i_{k+1})]}} V_{(m_1, \dots, m_{k+1})} > \delta_1 E \middle| (Y_{i_1}, \dots, Y_{i_{k+1}}) = (y_{i_1}, \dots, y_{i_{k+1}}) \right). \tag{91}
\end{aligned}$$

We know that

$$E \geq \max \left\{ \max_{\substack{(y_{i_1}, \dots, y_{i_{k+1}}) \in \mathcal{J} \\ (i_1, \dots, i_{k+1}) \in \mathcal{I}}} \max_{\substack{a \in \mathcal{H}_{(i_1, \dots, i_{k+1})} \\ 1 \leq |a| \leq k}} \mathbb{E} \left[\sum_{\substack{(j_1, \dots, j_{k+1}) \in \mathcal{J}: \\ (j_1, \dots, j_{k+1}) \sim [a, (i_1, \dots, i_{k+1})]}} V_{(j_1, \dots, j_{k+1})} \middle| (Y_{i_1}, \dots, Y_{i_{k+1}}) = (y_{i_1}, \dots, y_{i_{k+1}}) \right], \mathbb{E}[U] \right\},$$

and for $\gamma > 0$, $\nu > 1$ there exists $\delta_1, \delta_2, \dots, \delta_{k+1}$ such that for all $i \in [1 : k+1]$, $\delta_i > 1$ and for $\delta_0 = \nu$, $\frac{1}{(2(k+1))^{k+1}} \left(\frac{\delta_{i-1}-1}{2\gamma} E - (k+1)! \right) > \delta_i E$.

We will use this to show that the choices of γ' , ν' , E' , β' satisfy the conditions in the induction hypothesis.

$$\begin{aligned} \mathbb{E}[U'] &= \mathbb{E} \left[\sum_{(j_1, \dots, j_{k+1-l}) \in \mathcal{J}'} V'_{(j_1, \dots, j_{k+1-l})} \right] \\ &= \mathbb{E} \left[\sum_{\substack{(m_1, \dots, m_{k+1}) \in \mathcal{J}: \\ (m_1, \dots, m_{k+1}) \sim [a, (i_1, \dots, i_{k+1})]}} V_{(m_1, \dots, m_{k+1})} \middle| (Y_{i_1}, \dots, Y_{i_{k+1}}) = (y_{i_1}, \dots, y_{i_{k+1}}) \right] \\ &\leq E = E' \end{aligned}$$

For $(j_1, \dots, j_{k+1-l}) \in \mathcal{J}'$, $a' \in \mathcal{H}_{(j_1, \dots, j_{k+1-l})}$ with $|a'| = l'$ for $1 \leq l' \leq k-l$, define a $(k+1)$ -length tuple a'' as

$$a''_l = \begin{cases} a_l, & \text{if } a_l \neq *, \\ a'_{l-|a'_1|}, & \text{if } a_l = *. \end{cases}$$

for all $l \in [1 : k+1]$. Let $(m_1, \dots, m_{k+1}) \in \mathcal{J}$ be such that $(j_1, \dots, j_{k+1-l}) + a = (m_1, \dots, m_{k+1})$. Then, for fixed $(y_{j_1}, \dots, y_{j_{k+1-l}})$,

$$\begin{aligned} &\mathbb{E} \left[\sum_{\substack{(g_1, \dots, g_{k+1-l}) \in \mathcal{J}': \\ (g_1, \dots, g_{k+1-l}) \sim [a', (j_1, \dots, j_{k+1-l})]}} V'_{(g_1, \dots, g_{k+1-l})} \middle| (Y_{j_1}, \dots, Y_{j_{k+1-l}}) = (y_{j_1}, \dots, y_{j_{k+1-l}}) \right] \\ &= \mathbb{E} \left[\sum_{\substack{(h_1, \dots, h_{k+1}) \in \mathcal{J}: \\ (h_1, \dots, h_{k+1}) \sim [a'', (m_1, \dots, m_{k+1})]}} V_{(h_1, \dots, h_{k+1})} \middle| \begin{array}{l} (Y_{j_1}, \dots, Y_{j_{k+1-l}}) = (y_{j_1}, \dots, y_{j_{k+1-l}}), \\ (Y_{i_1}, \dots, Y_{i_{k+1}}) = (y_{i_1}, \dots, y_{i_{k+1}}) \end{array} \right] \\ &\stackrel{(a)}{=} \mathbb{E} \left[\sum_{\substack{(h_1, \dots, h_{k+1}) \in \mathcal{J}: \\ (h_1, \dots, h_{k+1}) \sim [a'', (m_1, \dots, m_{k+1})]}} V_{(h_1, \dots, h_{k+1})} \middle| (Y_{m_1}, \dots, Y_{m_{k+1}}) = (y_{m_1}, \dots, y_{m_{k+1}}) \right] \\ &\leq E = E'. \end{aligned}$$

In the above, (a) follows from definition of \mathcal{I}' and \mathcal{J}' .

Now, we need to show that for $\nu' = \delta'_0 = \delta_1$, $\gamma' = \gamma$, there exists $\delta'_1, \delta'_2, \dots, \delta'_{\beta'}$ such that for all $i \in [1 : \beta']$, $\delta'_i > 1$ and $\frac{1}{(2\beta')^{\beta'}} \left(\frac{\delta'_{i-1}-1}{2\gamma'} E' - \beta'! \right) > \delta'_i E'$. First note that as $l \in [1 : k]$, $\beta' \in [1 : k]$. We know that there exists

$\delta_1, \delta_2, \dots, \delta_{k+1}$ such that for all $i \in [1 : k+1]$, $\delta_i > 1$ and for $\delta_0 = \nu$, $\frac{1}{(2(k+1))^{k+1}} \left(\frac{\delta_{i-1}-1}{2\gamma} E - (k+1)! \right) > \delta_i E$. Let $\delta'_i = \delta_{i+1}$ for all $i \in [1 : \beta']$. Then, for all $i \in [1 : \beta']$, $\delta'_i > 1$ and

$$\begin{aligned} & \frac{1}{(2\beta')^{\beta'}} \left(\frac{\delta'_{i-1}-1}{2\gamma'} E' - (\beta')! \right) \\ &= \frac{1}{(2\beta')^{\beta'}} \left(\frac{\delta_i-1}{2\gamma} E - (\beta')! \right) \\ &\geq \frac{1}{(2(k+1))^{k+1}} \left(\frac{\delta_i-1}{2\gamma} E - (k+1)! \right) \\ &\geq \delta_{i+1} E \\ &= \delta'_i E'. \end{aligned}$$

With this, all the conditions in the induction hypothesis are satisfied and we are ready to apply induction hypothesis. Thus,

$$\begin{aligned} &= \mathbb{P} \left(\sum_{\substack{(m_1, \dots, m_{k+1}) \in \mathcal{J}: \\ (m_1, \dots, m_{k+1}) \sim [a, (i_1, \dots, i_{k+1})]}} V_{(m_1, \dots, m_{k+1})} > \delta_1 E \mid (Y_{i_1}, \dots, Y_{i_{k+1}}) = (y_{i_1}, \dots, y_{i_{k+1}}) \right) \\ &\stackrel{(a)}{=} \mathbb{P}(U' \geq \delta_1 E) \\ &= (|\mathcal{I}|(k+1-l) + 1)^{(k+1-l)^2} e^{-\gamma/3}, \end{aligned} \tag{92}$$

where (a) uses (91). Continuing the analysis of (90),

$$\begin{aligned} & \sum_{\substack{a \in \mathcal{H}(i_1, \dots, i_{k+1}) \\ 1 \leq |a| \leq k}} \mathbb{P} \left(\sum_{\substack{(j_1, \dots, j_{k+1}) \in \mathcal{J}: \\ (j_1, \dots, j_{k+1}) \sim [a, (i_1, \dots, i_{k+1})]}} V_{(j_1, \dots, j_{k+1})} > \delta_1 E \mid (Y_{i_1}, \dots, Y_{i_{k+1}}) = (y_{i_1}, \dots, y_{i_{k+1}}) \right) \\ &= \sum_{l=1}^k \sum_{\substack{a \in \mathcal{H}(i_1, \dots, i_{k+1}) \\ |a|=l}} \mathbb{P} \left(\sum_{\substack{(j_1, \dots, j_{k+1}) \in \mathcal{J}: \\ (j_1, \dots, j_{k+1}) \sim [a, (i_1, \dots, i_{k+1})]}} V_{(j_1, \dots, j_{k+1})} > \delta_1 E \mid (Y_{i_1}, \dots, Y_{i_{k+1}}) = (y_{i_1}, \dots, y_{i_{k+1}}) \right) \\ &\stackrel{(b)}{\leq} \sum_{l=1}^k \sum_{\substack{a \in \mathcal{H}(i_1, \dots, i_{k+1}) \\ |a|=l}} (|\mathcal{I}|(k+1-l) + 1)^{(k+1-l)^2} e^{-\gamma/3} \\ &= \sum_{l=1}^k \binom{k+1}{l} \binom{k+1}{l} l! (|\mathcal{I}|(k+1-l) + 1)^{(k+1-l)^2} e^{-\gamma/3} \\ &\stackrel{(c)}{=} \sum_{m=1}^k \binom{k+1}{k+1-m} \binom{k+1}{k+1-m} (k+1-m)! (|\mathcal{I}|m+1)^{m^2} e^{-\gamma/3} \\ &= \sum_{m=1}^k \binom{k+1}{k+1-m} \frac{(k+1)!}{m!} (|\mathcal{I}|m+1)^{m^2} e^{-\gamma/3} \\ &\leq \sum_{m=1}^k \binom{k+1}{m} ((k+1)!) (|\mathcal{I}|k+1)^{km} e^{-\gamma/3} \end{aligned}$$

$$\begin{aligned}
&\leq \sum_{m=0}^{k+1} \binom{k+1}{m} ((k+1)!) (|\mathcal{I}|k+1)^{km} e^{-\gamma/3} \\
&= (k+1)! e^{-\gamma/3} \sum_{m=0}^{k+1} \binom{k+1}{m} \left((|\mathcal{I}|k+1)^k \right)^m \\
&\leq (k+1)! e^{-\gamma/3} \left((|\mathcal{I}|k+1)^k + 1 \right)^{k+1} \\
&\leq (k+1)^{(k+1)} e^{-\gamma/3} \left((|\mathcal{I}|k+1) + 1 \right)^{k(k+1)}
\end{aligned}$$

Inequality (b) uses (92). The equality (c) is obtained by substituting l with $k+1-m$. Thus, using this analysis, we see that for $\beta = k+1$,

$$\begin{aligned}
\mathbb{P}(U \geq \nu E) &\leq e^{-\gamma/3} + \sum_{(i_1, \dots, i_{k+1}) \in \mathcal{J}} \mathbb{P} \left(\tilde{U}_{(i_1, \dots, i_{k+1})} > \frac{(\nu-1)E}{2\gamma} \right) \\
&\leq e^{-\gamma/3} + \sum_{(i_1, \dots, i_{k+1}) \in \mathcal{J}} (k+1)^{(k+1)} e^{-\gamma/3} (|\mathcal{I}|(k+1) + 1)^{k(k+1)} \\
&= e^{-\gamma/3} + |\mathcal{J}| (k+1)^{(k+1)} e^{-\gamma/3} (|\mathcal{I}|(k+1) + 1)^{k(k+1)} \\
&\leq e^{-\gamma/3} + |\mathcal{I}|^{k+1} (k+1)^{(k+1)} e^{-\gamma/3} (|\mathcal{I}|(k+1) + 1)^{k(k+1)} \\
&\leq e^{-\gamma/3} + (|\mathcal{I}|(k+1))^{k+1} e^{-\gamma/3} (|\mathcal{I}|(k+1) + 1)^{k(k+1)} \\
&\leq (|\mathcal{I}|(k+1) + 1)^{k(k+1)} e^{-\gamma/3} + (|\mathcal{I}|(k+1))^{k+1} e^{-\gamma/3} (|\mathcal{I}|(k+1) + 1)^{k(k+1)} \\
&\leq ((|\mathcal{I}|(k+1))^{k+1} + 1) e^{-\gamma/3} (|\mathcal{I}|(k+1) + 1)^{k(k+1)} \\
&\leq (|\mathcal{I}|(k+1) + 1)^{k+1} e^{-\gamma/3} (|\mathcal{I}|(k+1) + 1)^{k(k+1)} \\
&\leq e^{-\gamma/3} (|\mathcal{I}|(k+1) + 1)^{(k+1)(k+1)}
\end{aligned}$$

□

Lemma 13. For any $\epsilon > 0$, $n \geq n_0(\epsilon)$, $N_1, N_2, N_3 \geq \exp(n\epsilon)$ and types $P_1 \in \mathcal{P}_{\mathcal{X}_1}^n$, $P_2 \in \mathcal{P}_{\mathcal{X}_2}^n$, $P_3 \in \mathcal{P}_{\mathcal{X}_3}^n$; there exists codebooks $\{\mathbf{x}_{11}, \dots, \mathbf{x}_{1N_1} \in \mathcal{X}_1^n\}$, $\{\mathbf{x}_{21}, \dots, \mathbf{x}_{2N_2} \in \mathcal{X}_2^n\}$, $\{\mathbf{x}_{31}, \dots, \mathbf{x}_{3N_3} \in \mathcal{X}_3^n\}$ whose codewords are of type P_1, P_2, P_3 respectively such that for every permutation (i, j, k) of $(1, 2, 3)$; for every $(\mathbf{x}_i, \mathbf{x}_j, \mathbf{x}_k) \in \mathcal{X}_i^n \times \mathcal{X}_j^n \times \mathcal{X}_k^n$; for every joint type $P_{X_i X'_i X_j X'_j X_k X'_k} \in \mathcal{P}_{\mathcal{X}_i \times \mathcal{X}_i \times \mathcal{X}_j \times \mathcal{X}_j \times \mathcal{X}_k \times \mathcal{X}_k}^n$; and for $R_i \stackrel{\text{def}}{=} (1/n) \log_2 N_i$, $R_j \stackrel{\text{def}}{=} (1/n) \log_2 N_j$, and $R_k \stackrel{\text{def}}{=} (1/n) \log_2 N_k$; the following holds:

$$|\{r \in [1 : N_i] : (\mathbf{x}_{ir}, \mathbf{x}_k) \in T_{X_i X_k}^n\}| < \exp \{n (|R_i - I(X_i; X_k)|^+ + \epsilon/2)\}; \quad (93)$$

$$|\{s \in [1 : N_j] : (\mathbf{x}_i, \mathbf{x}_{js}, \mathbf{x}_k) \in T_{X_i X_j X_k}^n\}| < \exp \{n (|R_j - I(X_j; X_i, X_k)|^+ + \epsilon/2)\}; \quad (94)$$

$$|\{u \in [1 : N_i] : (\mathbf{x}_{iu}, \mathbf{x}_i, \mathbf{x}_j, \mathbf{x}_k) \in T_{X'_i X_i X_j X_k}^n\}| \leq \exp \left(n \left(|R_1 - I(X'_i; X_i X_j X_k)|^+ + \epsilon/2 \right) \right); \quad (95)$$

$$\begin{aligned}
&|\{(r, s) \in [1 : N_i] \times [1 : N_j] : (\mathbf{x}_{ir}, \mathbf{x}_{js}, \mathbf{x}_k) \in T_{X_i X_j X_k}^n\}| \\
&\leq \exp \left\{ n \left(\left| |R_i - I(X_i; X_k)|^+ + |R_j - I(X_j; X_k)|^+ - I(X_i; X_j | X_k) \right|^+ + \epsilon/2 \right) \right\}; \quad (96)
\end{aligned}$$

$$\begin{aligned}
&|\{(r, u) \in [1 : N_i] \times [1 : N_i] : (\mathbf{x}_{ir}, \mathbf{x}_{iu}, \mathbf{x}_k) \in T_{X_i X'_i X_k}^n, r \neq u\}| \\
&\leq \exp \left\{ n \left(\left| |R_i - I(X_i; X_k)|^+ + |R_i - I(X'_i; X_k)|^+ - I(X_i; X'_i | X_k) \right|^+ + \epsilon/2 \right) \right\}; \quad (97)
\end{aligned}$$

$$\begin{aligned}
& |\{(s, v) \in [1 : N_j] \times [1 : N_j] : (\mathbf{x}_{js}, \mathbf{x}_{jv}, \mathbf{x}_k) \in T_{X_j X'_j X_k}^n, s \neq v\}| \\
& \leq \exp \left\{ n \left(|R_j - I(X_j; X_k)|^+ + |R_j - I(X'_j; X_k)|^+ - I(X_j; X'_j | X_k) \right)^+ + \epsilon/2 \right\}; \tag{98}
\end{aligned}$$

$$\begin{aligned}
& |\{(r, w) \in [1 : N_i] \times [1 : N_k] : (\mathbf{x}_{ir}, \mathbf{x}_{kw}, \mathbf{x}_k) \in T_{X_i X'_i X_k}^n\}| \\
& \leq \exp \left\{ n \left(|R_i - I(X_i; X_k)|^+ + |R_k - I(X'_k; X_k)|^+ - I(X_i; X'_k | X_k) \right)^+ + \epsilon/2 \right\}; \tag{99}
\end{aligned}$$

$$\begin{aligned}
& |\{(s, w) \in [1 : N_j] \times [1 : N_k] : (\mathbf{x}_{js}, \mathbf{x}_{kw}, \mathbf{x}_k) \in T_{X_j X'_j X_k}^n\}| \\
& \leq \exp \left\{ n \left(|R_j - I(X_j; X_k)|^+ + |R_k - I(X'_k; X_k)|^+ - I(X_j; X'_k | X_k) \right)^+ + \epsilon/2 \right\}; \tag{100}
\end{aligned}$$

$$\begin{aligned}
& |\{(u, v) \in [1 : N_i] \times [1 : N_j] : (\mathbf{x}_{iu}, \mathbf{x}_{jv}, \mathbf{x}_i, \mathbf{x}_j, \mathbf{x}_k) \in T_{X'_i X'_j X_i X_j X_k}^n\}| \\
& \leq \exp \left(n \left(|R_i - I(X'_i; X_i X_j X_k)|^+ + |R_j - I(X'_j; X_i X_j X_k)|^+ - I(X'_i; X'_j | X_i X_j X_k) \right)^+ + \epsilon/2 \right) \tag{101}
\end{aligned}$$

$$\begin{aligned}
& |\{(u, w) \in [1 : N_i] \times [1 : N_k] : (\mathbf{x}_{iu}, \mathbf{x}_{kw}, \mathbf{x}_i, \mathbf{x}_j, \mathbf{x}_k) \in T_{X'_i X'_j X_i X_j X_k}^n\}| \\
& \leq \exp \left(n \left(|R_i - I(X'_i; X_i X_j X_k)|^+ + |R_k - I(X'_k; X_i X_j X_k)|^+ - I(X'_i; X'_k | X_i X_j X_k) \right)^+ + \epsilon/2 \right) \tag{102}
\end{aligned}$$

$$\begin{aligned}
& |\{(r, s, u) \in [1 : N_i] \times [1 : N_j] \times [1 : N_i] : (\mathbf{x}_{ir}, \mathbf{x}_{js}, \mathbf{x}_{iu}, \mathbf{x}_k) \in T_{X_i X_j X'_i X_k}^n, r \neq u\}| \\
& \leq \max_{S \subseteq \{1, 2, 3\}} \exp \left\{ n \left(g_{X_i, X_j, X'_i, X_k}^S(R_i, R_j, R_i) + \epsilon/2 \right) \right\}; \text{ and} \tag{103}
\end{aligned}$$

$$\begin{aligned}
& |\{(r, s, u, v) \in [1 : N_i] \times [1 : N_j] \times [1 : N_i] \times [1 : N_j] : (\mathbf{x}_{ir}, \mathbf{x}_{js}, \mathbf{x}_{iu}, \mathbf{x}_{jv}, \mathbf{x}_k) \in T_{X_i X_j X'_i X'_j X_k}^n, r \neq u, s \neq v\}| \\
& \leq \max_{S \subseteq \{1, 2, 3, 4\}} \exp \left\{ n \left(g_{X_i, X_j, X'_i, X'_j, X_k}^S(R_i, R_j, R_i, R_j) + \epsilon/2 \right) \right\} \tag{104}
\end{aligned}$$

$$\begin{aligned}
& |\{(r, s, u, w) \in [1 : N_i] \times [1 : N_j] \times [1 : N_i] \times [1 : N_k] : (\mathbf{x}_{ir}, \mathbf{x}_{js}, \mathbf{x}_{iu}, \mathbf{x}_{jv}, \mathbf{x}_k) \in T_{X_i X_j X'_i X'_j X_k}^n, r \neq u\}| \\
& \leq \max_{S \subseteq \{1, 2, 3, 4\}} \exp \left\{ n \left(g_{X_i, X_j, X'_i, X'_k, X_k}^S(R_i, R_j, R_i, R_k) + \epsilon/2 \right) \right\}. \tag{105}
\end{aligned}$$

Proof. We will generate the codebooks by a random experiment. For fixed $(\mathbf{x}_i, \mathbf{x}_j, \mathbf{x}_k) \in \mathcal{X}_i^n \times \mathcal{X}_j^n \times \mathcal{X}_k^n$ and joint type $P_{X_i X'_i X_j X'_j X_k X'_k} \in \mathcal{P}_{\mathcal{X}_i \times \mathcal{X}_i \times \mathcal{X}_j \times \mathcal{X}_j \times \mathcal{X}_k \times \mathcal{X}_k}^n$, we will show that the probability that each of the statements (93) - (105) does not hold, falls doubly exponentially in n . Since $|\mathcal{X}_i^n|$, $|\mathcal{X}_j^n|$, $|\mathcal{X}_k^n|$ and $|\mathcal{P}_{\mathcal{X}_i \times \mathcal{X}_i \times \mathcal{X}_j \times \mathcal{X}_j \times \mathcal{X}_k \times \mathcal{X}_k}^n|$ grow only exponentially in n , a union bound will imply that the probability that any of the statements (93) - (105) fail for some $\mathbf{x}_i, \mathbf{x}_j, \mathbf{x}_k$ and $P_{X_i X'_i X_j X'_j X_k X'_k}$ also falls doubly exponentially. This will show the existence of a codebook satisfying (93) - (105). The proof will employ Lemma 11 which we have restated below for quick reference.

Lemma. For an index set \mathcal{I} , let $\{Y_i : i \in \mathcal{I}\}$ be a set of independent random variables. Let β be a positive integer. Let $\mathcal{J} \subseteq \mathcal{I}^\beta$ be a set of β length tuples consisting of distinct elements from \mathcal{I} . For $(i_1, \dots, i_\beta) \in \mathcal{J}$, let $V_{(i_1, \dots, i_\beta)}$ be a binary random variable which is a function of $Y_{i_1}, \dots, Y_{i_\beta}$. Suppose $U = \sum_{(i_1, \dots, i_\beta) \in \mathcal{J}} V_{(i_1, \dots, i_\beta)}$. Let

$$E \geq \max \left\{ \max_{(i_1, \dots, i_\beta) \in \mathcal{J}} \max_{\substack{a \in \mathcal{H}_{(i_1, \dots, i_\beta)} \\ 1 \leq |a| \leq \beta - 1}} \mathbb{E} \left[\sum_{\substack{(j_1, \dots, j_\beta) \in \mathcal{J} \\ (j_1, \dots, j_\beta) \sim [a, (i_1, \dots, i_\beta)]}} V_{(j_1, \dots, j_\beta)} \middle| (Y_{i_1}, \dots, Y_{i_\beta}) = (y_{i_1}, \dots, y_{i_\beta}) \right], \mathbb{E}[U] \right\}, \tag{106}$$

For $\gamma > 0$, $\nu > 1$ if there exists $\delta_1, \delta_2, \dots, \delta_\beta > 1$ such that for all $i \in [1 : \beta]$, $\frac{1}{(2\beta)^\beta} \left(\frac{\delta_{i-1} - 1}{2\gamma} E - \beta! \right) > \delta_i E$ for $\delta_0 := \nu$, then

$$\mathbb{P}(U \geq \nu E) \leq (|\mathcal{I}| \beta + 1)^{\beta^2} e^{-\gamma/3}. \tag{107}$$

Let $T_l^n, l \in \{1, 2, 3\}$ denote the type class of P_l . We generate independent random codebooks for each user. The codebook for user $l \in \{1, 2, 3\}$, denoted by $(\mathbf{X}_{l1}, \mathbf{X}_{l2}, \dots, \mathbf{X}_{lN_l})$, consists of independent random vectors each distributed uniformly on T_l^n . Fix $(\mathbf{x}_i, \mathbf{x}_j, \mathbf{x}_k) \in \mathcal{X}_i^n \times \mathcal{X}_j^n \times \mathcal{X}_k^n$ and a joint type $P_{X_i X'_i X_j X'_j X_k X'_k} \in \mathcal{P}_{\mathcal{X}_i \times \mathcal{X}_i \times \mathcal{X}_j \times \mathcal{X}_j \times \mathcal{X}_k \times \mathcal{X}_k}^n$ such that for $l \in \{1, 2, 3\}$, $P_{X_l} = P_{X'_l} = P_l$ and $(\mathbf{x}_i, \mathbf{x}_j, \mathbf{x}_k) \in T_{X_i X_j X_k}^n$.

In order to obtain (93) - (105), we will use $\nu = \exp(n\epsilon/2)$ and $\gamma = \exp(n\epsilon/4\beta)$ in Lemma 11. For $i \in [1 : \beta]$, let $\delta_i = \exp\left(\frac{(4\beta-3i)n\epsilon}{8\beta}\right)$. Note that $\delta_i \geq 1$ for all $i \in [1 : \beta]$, $\delta_0 = \exp(n\epsilon/2) = \nu$ and there exists n_0 s.t. for all $n \geq n_0$,

$$\begin{aligned} \delta_i &= \exp\left(\frac{(4\beta-3i)n\epsilon}{8\beta}\right) \\ &< \left(\exp\left(\frac{(4\beta-3i+1)n\epsilon}{8\beta}\right)\right) \\ &= \frac{\delta_{i-1}}{\gamma} \\ &\approx \frac{1}{(2\beta)^\beta} \left(\frac{\delta_{i-1}-1}{2\gamma} - \frac{\beta!}{E}\right) \text{ for large } n. \end{aligned}$$

The choice of $\beta, \mathcal{I}, \mathcal{J}$ and the random variables will depend on the specific statement among (93) - (105). Though, β will only range in $\{1, 2, 3, 4\}$.

Analysis of (93), (94) and (95)

To obtain (93), choose $\mathcal{I} = \{i1, i2, \dots, iN_i\}$ and the set $\{\mathbf{X}_{i1}, \mathbf{X}_{i2}, \dots, \mathbf{X}_{iN_i}\}$ corresponding to $\{Y_i : i \in \mathcal{I}\}$. We choose $\beta = 1$ and $\mathcal{J} = \{(i1), (i2), \dots, (iN_i)\}$. For all $r \in [1 : N_i]$,

$$V_{(ir)} = \begin{cases} 1, & \text{if } \mathbf{X}_{ir} \in T_{X_i|X_k}^n(\mathbf{x}_k), \\ 0, & \text{otherwise.} \end{cases}$$

Note that

$$\begin{aligned} \mathbb{P}(V_{(ir)} = 1) &= \frac{|T_{X_i|X_k}^n|}{|T_{X_i}^n|} \\ &\leq \frac{\exp\{nH(X_i|X_k)\}}{(n+1)^{|\mathcal{X}_i|} \exp\{nH(X_i)\}} \\ &= (n+1)^{-|\mathcal{X}_i|} \exp\{-nI(X_i; X_k)\} \\ &\stackrel{(a)}{\leq} \exp\{-nI(X_i; X_k)\} \end{aligned}$$

where (a) follows because $(n+1)^{-|\mathcal{X}_i|} \leq 1$.

Note that $U = \sum_{r \in [1:N_i]} V_{(ir)} = |\{r \in [1 : N_i] : (\mathbf{X}_{ir}, \mathbf{x}_k) \in T_{X_i X_k}^n\}|$. Note that for the case of $\beta = 1$, condition (106) reduces to $E \geq \mathbb{E}[U]$. Thus, $\mathbb{E}[U] = \sum_{r \in [1:N_i]} \mathbb{E}[V_{(ir)}] = \sum_{r \in [1:N_i]} \mathbb{P}(V_{(ir)} = 1) \leq \exp\{n(R_i - I(X_i; X_k))\} \leq \exp\{n|R_i - I(X_i; X_k)|^+\} := E$. Thus, (107) gives us

$$\mathbb{P}(|\{r \in [1 : N_i] : (\mathbf{X}_{ir}, \mathbf{x}_k) \in T_{X_i X_k}^n\}| \geq \exp\{n(|R_i - I(X_i; X_k)|^+ + \epsilon/2)\}) \leq (N_i + 1)e^{-\exp(n\epsilon/4)/3}. \quad (108)$$

Replacing x_k with (x_i, x_j, x_k) , X_k with (X_i, X_j, X_k) , and X_i with X'_i in the above argument, one can show that

$$\begin{aligned} \mathbb{P}(|\{u \in [1 : N_i] : (\mathbf{X}_{iu}, \mathbf{x}_i, \mathbf{x}_j, \mathbf{x}_k) \in T_{X'_i X_i X_j X_k}^n\}| \geq \exp\{n(|R_i - I(X'_i; X_i X_j X_k X_k)|^+ + \epsilon/2)\}) \\ \leq (N_i + 1)e^{-\exp(n\epsilon/4)/3}. \end{aligned} \quad (109)$$

Similarly, choosing $\mathcal{I} = \{j1, j2, \dots, jN_j\}$, $\{Y_i : i \in \mathcal{I}\} = \{\mathbf{X}_{j1}, \mathbf{X}_{j2}, \dots, \mathbf{X}_{jN_j}\}$, $\mathcal{J} = \{(j1), (j2), \dots, (jN_j)\}$ and replacing \mathbf{x}_k with $(\mathbf{x}_i, \mathbf{x}_k)$, X_k with (X_i, X_k) , and R_i with R_j in the proof of (108), we can show that

$$\begin{aligned} \mathbb{P}\left(\left|\{s \in [1 : N_j] : (\mathbf{x}_i, \mathbf{X}_{js}, \mathbf{x}_k) \in T_{X_i X_j X_k}^n\right|\right) &\geq \exp\left\{n\left(|R_j - I(X_j; X_i X_k)|^+ + \epsilon/2\right)\right\} \\ &\leq (N_j + 1)e^{-\exp(n\epsilon/4)/3}. \end{aligned} \quad (110)$$

Analysis of (96) - (102)

We will only analyse (96) and (97). The analysis of other statements is similar. To show (96), choose $\mathcal{I} = \{i1, i2, \dots, iN_i\} \cup \{j1, j2, \dots, jN_j\}$, $\{Y_i : i \in \mathcal{I}\} = \{\mathbf{X}_{i1}, \mathbf{X}_{i2}, \dots, \mathbf{X}_{iN_i}\} \cup \{\mathbf{X}_{j1}, \mathbf{X}_{j2}, \dots, \mathbf{X}_{jN_j}\}$. For $\beta = 2$, let $\mathcal{J} = \{(ir, js) : (r, s) \in [1 : N_i] \times [1 : N_j]\}$. For all $(r, s) \in [1 : N_i] \times [1 : N_j]$,

$$V_{(ir, js)} = \begin{cases} 1, & \text{if } (\mathbf{X}_{ir}, \mathbf{X}_{js}) \in T_{X_i X_j | X_k}^n(\mathbf{x}_k), \\ 0, & \text{otherwise.} \end{cases}$$

This implies that $U = \sum_{(r, s) \in [1 : N_i] \times [1 : N_j]} V_{(ir, js)} = \left|\left\{(r, s) \in [1 : N_i] \times [1 : N_j] : (\mathbf{X}_{ir}, \mathbf{X}_{js}, \mathbf{x}_k) \in T_{X_i X_j X_k}^n\right\}\right|$.

Note that

$$\begin{aligned} \mathbb{P}(V_{(ir, js)} = 1) &= \frac{|T_{X_i X_j | X_k}^n|}{|T_{X_i}^n| |T_{X_j}^n|} \\ &\leq \frac{\exp\{nH(X_i X_j | X_k)\}}{(n+1)^{|\mathcal{X}_i| + |\mathcal{X}_j|} \exp\{n(H(X_i) + H(X_j))\}} \\ &= (n+1)^{-(|\mathcal{X}_i| + |\mathcal{X}_j|)} \exp\{-n(H(X_i X_j) - H(X_i X_j | X_k) - H(X_i X_j) + H(X_i) + H(X_j))\} \\ &= (n+1)^{-(|\mathcal{X}_i| + |\mathcal{X}_j|)} \exp\{-n(I(X_i X_j; X_k) + I(X_i; X_j))\} \\ &\leq \exp\{-n(I(X_i X_j; X_k) + I(X_i; X_j))\} \\ &= \exp\{-n(I(X_j; X_k) + I(X_i; X_k | X_j) + I(X_i; X_j))\} \\ &= \exp\{-n(I(X_j; X_k) + I(X_i; X_j X_k))\} \end{aligned}$$

Thus,

$$\begin{aligned} \mathbb{E}[U] &= \sum_{(r, s) \in [1 : N_i] \times [1 : N_j]} \mathbb{E}[V_{(ir, js)}] = \sum_{(r, s) \in [1 : N_i] \times [1 : N_j]} \mathbb{P}(V_{(ir, js)} = 1) \\ &\leq \exp\{n(R_i + R_j - I(X_i; X_j X_k) - I(X_j; X_k))\} \\ &\leq \exp\left\{n\left(|R_i - I(X_i; X_k)|^+ + |R_j - I(X_j; X_k)|^+ - I(X_i; X_j | X_k)\right)^+\right\} := E. \end{aligned} \quad (111)$$

We need to show that for any $(ir, js) \in \mathcal{J}$, and $(\mathbf{X}_{ir}, \mathbf{X}_{js}) = (\mathbf{x}_{ir}, \mathbf{x}_{js})$,

$E \geq \max\left(\mathbb{E}\left[\sum_{v \neq s} V_{(ir, jv)} | (\mathbf{X}_{ir}, \mathbf{X}_{js}) = (\mathbf{x}_{ir}, \mathbf{x}_{js})\right], \mathbb{E}\left[\sum_{u \neq r} V_{(iu, js)} | (\mathbf{X}_{ir}, \mathbf{X}_{js}) = (\mathbf{x}_{ir}, \mathbf{x}_{js})\right]\right)$. Note that

$$\begin{aligned} &\mathbb{E}\left[\sum_{v \neq s} V_{(ir, jv)} | (\mathbf{X}_{ir}, \mathbf{X}_{js}) = (\mathbf{x}_{ir}, \mathbf{x}_{js})\right] \\ &= \sum_{v \neq s} \mathbb{E}[V_{(ir, jv)} | (\mathbf{X}_{ir}, \mathbf{X}_{js}) = (\mathbf{x}_{ir}, \mathbf{x}_{js})] \\ &\leq \sum_{v \neq s} \mathbb{P}(V_{(ir, jv)} = 1 | (\mathbf{X}_{ir}, \mathbf{X}_{js}) = (\mathbf{x}_{ir}, \mathbf{x}_{js})) \end{aligned}$$

$$\begin{aligned}
&= \sum_{v \neq s} \mathbb{P} \left(\mathbf{X}_{jv} \in T_{X_j|X_iX_k}^n(\mathbf{x}_{ir}, \mathbf{x}_k) \right) \\
&= \sum_{v \neq s} \frac{|T_{X_j|X_iX_k}^n|}{|T_{X_j}^n|} \\
&\leq \exp \{nR_j\} \frac{\exp \{nH(X_j|X_iX_k)\}}{(n+1)^{|X_j|} \exp \{nH(X_j)\}} \\
&\leq \exp \{n(|R_j - I(X_j; X_iX_k)|^+)\} \\
&\leq E.
\end{aligned} \tag{112}$$

Similarly, we can show that $\mathbb{E} \left[\sum_{u \neq r} V_{(iu, js)}(\mathbf{X}_{ir}, \mathbf{X}_{js}) = (\mathbf{x}_{ir}, \mathbf{x}_{js}) \right] \leq E$.

Thus, (107) implies that

$$\begin{aligned}
&\mathbb{P} \left(\left| \left\{ (r, s) \in [1 : N_i] \times [1 : N_j] : (\mathbf{X}_{ir}, \mathbf{X}_{js}, \mathbf{x}_k) \in T_{X_iX_jX_k}^n \right\} \right| \right. \\
&\quad \left. \geq \exp \left\{ n \left(\left| |R_i - I(X_i; X_k)|^+ + |R_j - I(X_j; X_k)|^+ - I(X_i; X_j|X_k) \right|^+ + \epsilon/2 \right) \right\} \right) \\
&\leq ((N_i + N_j)2 + 1)^4 e^{-\exp(n\epsilon/8)/3}.
\end{aligned} \tag{113}$$

To show (97), let $\mathcal{I} = \{i1, i2, \dots, iN_i\}$ and $\{Y_i : i \in \mathcal{I}\} = \{\mathbf{X}_{i1}, \mathbf{X}_{i2}, \dots, \mathbf{X}_{iN_i}\}$. We choose $\beta = 2$ and $\mathcal{J} = \{(ir, iu) : (r, u) \in [1 : N_i] \times [1 : N_i] \text{ such that } r \neq u\}$. For all (r, u) such that $r \in [1 : N_i]$ and $u \in [1 : N_i] \setminus \{r\}$,

$$V_{(ir, iu)} = \begin{cases} 1, & \text{if } (\mathbf{X}_{ir}, \mathbf{X}_{iu}) \in T_{X_iX'_i|X_k}^n(\mathbf{x}_k), \\ 0, & \text{otherwise.} \end{cases}$$

By replacing X_j with X'_i in the proof of (113) and following similar arguments, we can show that

$$\begin{aligned}
&\mathbb{P} \left(\left| \left\{ (r, u) \in [1 : N_i] \times [1 : N_i] : (\mathbf{x}_{ir}, \mathbf{x}_{iu}, \mathbf{x}_k) \in T_{X_iX'_iX_k}^n, r \neq u \right\} \right| \right. \\
&\quad \left. \geq \exp \left\{ n \left(\left| |R_i - I(X_i; X_k)|^+ + |R_i - I(X'_i; X_k)|^+ - I(X_i; X'_i|X_k) \right|^+ + \epsilon/2 \right) \right\} \right) \\
&\leq (2N_i + 1)^4 e^{-\exp(n\epsilon/8)/3}.
\end{aligned} \tag{114}$$

Analysis of (103)

Choose $\mathcal{I} = \{i1, i2, \dots, iN_i\} \cup \{j1, j2, \dots, jN_j\}$, $\{Y_i : i \in \mathcal{I}\} = \{\mathbf{X}_{i1}, \mathbf{X}_{i2}, \dots, \mathbf{X}_{iN_i}\} \cup \{\mathbf{X}_{j1}, \mathbf{X}_{j2}, \dots, \mathbf{X}_{jN_j}\}$. For $\beta = 3$,

let $\mathcal{J} = \{(ir, js, iu) : (r, s, u) \in [1 : N_i] \times [1 : N_j] \times [1 : N_i], r \neq u\}$. For all $(ir, js, iu) \in \mathcal{J}$,

$$V_{(ir, js, iu)} = \begin{cases} 1, & \text{if } (\mathbf{X}_{ir}, \mathbf{X}_{js}, \mathbf{X}_{iu}) \in T_{X_iX_jX'_i|X_k}^n(\mathbf{x}_k), \\ 0, & \text{otherwise.} \end{cases}$$

Therefore, $U = \sum_{(ir, js, iu) \in \mathcal{J}} V_{(ir, js, iu)} = |\{(r, s, u) \in [1 : N_i] \times [1 : N_j] \times [1 : N_i] : (\mathbf{X}_{ir}, \mathbf{X}_{js}, \mathbf{X}_{iu}, \mathbf{x}_k) \in T_{X_iX_jX'_iX_k}^n, r \neq u\}|$.

Note that

$$\mathbb{P}(V_{(ir, js, iu)} = 1) = \frac{|T_{X_iX_jX'_i|X_k}^n|}{|T_{X_i}^n| |T_{X_j}^n| |T_{X'_i}^n|}$$

$$\begin{aligned}
&\leq \frac{\exp\{nH(X_i X_j X'_i | X_k)\}}{(n+1)^{2|\mathcal{X}_i|+|\mathcal{X}_j|} \exp\{n(H(X_i) + H(X_j) + H(X'_i))\}} \\
&= (n+1)^{-(2|\mathcal{X}_i|+|\mathcal{X}_j|)} \exp\{n(H(X_i X_j X'_i X_k) - H(X_i) - H(X_j) - H(X'_i) - H(X_k))\} \\
&\stackrel{(a)}{=} (n+1)^{-(|\mathcal{X}_i|+|\mathcal{X}_j|)} \exp\{-n(C(X_i; X_j; X'_i; X_k))\} \\
&\leq \exp\{-n(C(X_i; X_j; X'_i; X_k))\}
\end{aligned}$$

where (a) follows from (86).

Note that

$$\mathbb{E}[U] = \sum_{(ir, js, iu) \in \mathcal{J}} \mathbb{E}[V_{(ir, js, iu)}] = \sum_{(ir, js, iu) \in \mathcal{J}} \mathbb{P}(V_{(ir, js, iu)} = 1) \quad (115)$$

$$\leq \exp\{n(2R_i + R_j - C(X_i; X_j; X'_i; X_k))\} \quad (116)$$

$$\leq \max_{S \subseteq \{1, 2, 3\}} \exp\left\{n\left(g_{X_i, X_j, X'_i, X_k}^S(R_i, R_j, R_i)\right)\right\}. \quad (117)$$

This is because for $S = \{1, 2, 3\}$, $\exp\left\{n\left(g_{X_i, X_j, X'_i, X_k}^S(R_i, R_j, R_i)\right)\right\} = \exp\{n(2R_i + R_j - C(X_i; X_j; X'_i; X_k))\}$.

Let $E := \max_{S \subseteq \{1, 2, 3\}} \exp\left\{n\left(g_{X_i, X_j, X'_i, X_k}^S(R_i, R_j, R_i)\right)\right\}$. Using similar arguments as the ones used to obtain (111) and (112), we can show that for any $(ir, js, iu) \in \mathcal{J}$, and $(\mathbf{X}_{ir}, \mathbf{X}_{js}, \mathbf{X}_{iu}) = (\mathbf{x}_{ir}, \mathbf{x}_{js}, \mathbf{x}_{iu})$,

$$\begin{aligned}
E \geq \max &\left(\mathbb{E} \left[\sum_{v \neq s} V_{(ir, jv, iu)} | (\mathbf{X}_{ir}, \mathbf{X}_{js}, \mathbf{X}_{iu}) = (\mathbf{x}_{ir}, \mathbf{x}_{js}, \mathbf{x}_{iu}) \right], \right. \\
&\mathbb{E} \left[\sum_{r' \notin \{r, u\}} V_{(ir', js, iu)} | (\mathbf{X}_{ir}, \mathbf{X}_{js}, \mathbf{X}_{iu}) = (\mathbf{x}_{ir}, \mathbf{x}_{js}, \mathbf{x}_{iu}) \right], \\
&\mathbb{E} \left[\sum_{u' \notin \{r, u\}} V_{(ir, js, iu')} | (\mathbf{X}_{ir}, \mathbf{X}_{js}, \mathbf{X}_{iu}) = (\mathbf{x}_{ir}, \mathbf{x}_{js}, \mathbf{x}_{iu}) \right], \\
&\mathbb{E} \left[\sum_{r', u' \notin \{r, u\}} V_{(ir', js, iu')} | (\mathbf{X}_{ir}, \mathbf{X}_{js}, \mathbf{X}_{iu}) = (\mathbf{x}_{ir}, \mathbf{x}_{js}, \mathbf{x}_{iu}) \right], \\
&\mathbb{E} \left[\sum_{r' \notin \{r, u\}, v \neq s} V_{(ir', jv, iu)} | (\mathbf{X}_{ir}, \mathbf{X}_{js}, \mathbf{X}_{iu}) = (\mathbf{x}_{ir}, \mathbf{x}_{js}, \mathbf{x}_{iu}) \right], \\
&\left. \mathbb{E} \left[\sum_{u' \notin \{r, u\}, v \neq s} V_{(ir, jv, iu')} | (\mathbf{X}_{ir}, \mathbf{X}_{js}, \mathbf{X}_{iu}) = (\mathbf{x}_{ir}, \mathbf{x}_{js}, \mathbf{x}_{iu}) \right] \right).
\end{aligned}$$

Thus, we can use (107) to obtain

$$\begin{aligned}
&\mathbb{P}\left(\left|\{(r, s, u) \in [1 : N_i] \times [1 : N_j] \times [1 : N_i] : (\mathbf{X}_{ir}, \mathbf{X}_{js}, \mathbf{X}_{iu}, \mathbf{x}_k) \in T_{X_i X_j X'_i X_k}^n, r \neq u\}\right|\right. \\
&\quad \left. > \max_{S \subseteq \{1, 2, 3\}} \exp\left\{n\left(g_{X_i, X_j, X'_i, X_k}^S(R_i, R_j, R_i) + \epsilon/2\right)\right\}\right) \\
&\leq (3(N_i + N_j) + 1)^9 e^{-\exp(n\epsilon/12)/3}. \quad (118)
\end{aligned}$$

Analysis of (104) and (105)

We will start with analysis of (105). Choose $\mathcal{I} = \{i1, i2, \dots, iN_i\} \cup \{j1, j2, \dots, jN_j\} \cup \{k1, k2, \dots, kN_k\}$, $\{Y_i : i \in \mathcal{I}\} = \{\mathbf{X}_{i1}, \mathbf{X}_{i2}, \dots, \mathbf{X}_{iN_i}\} \cup \{\mathbf{X}_{j1}, \mathbf{X}_{j2}, \dots, \mathbf{X}_{jN_j}\} \cup \{\mathbf{X}_{k1}, \mathbf{X}_{k2}, \dots, \mathbf{X}_{kN_k}\}$. For $\beta = 4$, let $\mathcal{J} = \{(ir, js, iu, kw) : (r, s, u, w) \in [1 : N_i] \times [1 : N_j] \times [1 : N_i] \times [1 : N_k], r \neq u\}$. For all $(ir, js, iu, kw) \in \mathcal{J}$,

$$V_{(ir, js, iu, kw)} = \begin{cases} 1, & \text{if } (\mathbf{X}_{ir}, \mathbf{X}_{js}, \mathbf{X}_{iu}, \mathbf{X}_{kw}) \in T_{X_i X_j X'_i X'_k | X_k}^n(\mathbf{x}_k), \\ 0, & \text{otherwise.} \end{cases}$$

Therefore, $U = \sum_{(ir, js, iu, kw) \in \mathcal{J}} V_{(ir, js, iu, kw)} = |\{(r, s, u, w) \in [1 : N_i] \times [1 : N_j] \times [1 : N_i] \times [1 : N_k] : (\mathbf{X}_{ir}, \mathbf{X}_{js}, \mathbf{X}_{iu}, \mathbf{X}_{kw}) \in T_{X_i X_j X'_i X'_k | X_k}^n, r \neq u\}|$.

Note that

$$\begin{aligned} \mathbb{P}(V_{(ir, js, iu, kw)} = 1) &= \frac{|T_{X_i X_j X'_i X'_k | X_k}^n|}{|T_{X_i}^n| |T_{X_j}^n| |T_{X'_i}^n| |T_{X'_k}^n|} \\ &\leq \frac{\exp\{nH(X_i X_j X'_i X'_k | X_k)\}}{(n+1)^{2|\mathcal{X}_i| + |\mathcal{X}_j| + |\mathcal{X}_k|} \exp\{n(H(X_i) + H(X_j) + H(X'_i) + H(X'_k))\}} \\ &= (n+1)^{-(2|\mathcal{X}_i| + |\mathcal{X}_j|)} \exp\{n(H(X_i X_j X'_i X'_k | X_k) - H(X_i) - H(X_j) - H(X'_i) - H(X'_k) - H(X_k))\} \\ &\stackrel{(a)}{=} (n+1)^{-(|\mathcal{X}_i| + |\mathcal{X}_j|)} \exp\{-n(C(X_i; X_j; X'_i; X'_k; X_k))\} \\ &\leq \exp\{-n(C(X_i; X_j; X'_i; X'_k; X_k))\} \end{aligned}$$

where (a) follows from (86).

Note that $\mathbb{E}[U] = \sum_{(ir, js, iu, kw) \in \mathcal{J}} \mathbb{E}[V_{(ir, js, iu, kw)}] = \sum_{(ir, js, iu, kw) \in \mathcal{J}} \mathbb{P}(V_{(ir, js, iu, kw)} = 1) \leq \exp\{n(2R_i + R_j + R_k - C(X_i; X_j; X'_i; X'_k; X_k))\} \leq \max_{\mathcal{S} \subseteq \{1, 2, 3, 4\}} \exp\left\{n\left(g_{X_i, X_j, X'_i, X'_k, X_k}^{\mathcal{S}}(R_i, R_j, R_i, R_k)\right)\right\}$. This is because for $\mathcal{S} = \{1, 2, 3, 4\}$, $\exp\left\{n\left(g_{X_i, X_j, X'_i, X'_k, X_k}^{\mathcal{S}}(R_i, R_j, R_i, R_k)\right)\right\} = \exp\{n(2R_i + R_j + R_k - C(X_i; X_j; X'_i; X'_k; X_k))\}$. Using similar arguments as used on (111), (112) and (117), one can show that $E := \max_{\mathcal{S} \subseteq \{1, 2, 3, 4\}} \exp\left\{n\left(g_{X_i, X_j, X'_i, X'_k, X_k}^{\mathcal{S}}(R_i, R_j, R_i, R_k)\right)\right\}$ satisfies condition (106). Using (107), we obtain that

$$\begin{aligned} &\mathbb{P}\left(|\{(r, s, u, w) \in [1 : N_i] \times [1 : N_j] \times [1 : N_i] \times [1 : N_k] : (\mathbf{X}_{ir}, \mathbf{X}_{js}, \mathbf{X}_{iu}, \mathbf{X}_{kw}) \in T_{X_i X_j X'_i X'_k | X_k}^n, r \neq u\}| \right. \\ &\quad \left. > \max_{\mathcal{S} \subseteq \{1, 2, 3, 4\}} \exp\left\{n\left(g_{X_i, X_j, X'_i, X'_k, X_k}^{\mathcal{S}}(R_i, R_j, R_i, R_k) + \epsilon/2\right)\right\}\right) \\ &\leq (4(N_i + N_j + N_k) + 1)^{16} e^{-\exp(n\epsilon/16)/3}. \end{aligned} \tag{119}$$

The analysis of (104) is very similar to that of (105). For (104), we choose $\mathcal{I} = \{i1, i2, \dots, iN_i\} \cup \{j1, j2, \dots, jN_j\}$, $\{Y_i : i \in \mathcal{I}\} = \{\mathbf{X}_{i1}, \mathbf{X}_{i2}, \dots, \mathbf{X}_{iN_i}\} \cup \{\mathbf{X}_{j1}, \mathbf{X}_{j2}, \dots, \mathbf{X}_{jN_j}\}$. For $\beta = 4$, let $\mathcal{J} = \{(ir, js, iu, jv) : (r, s, u, v) \in [1 : N_i] \times [1 : N_j] \times [1 : N_i] \times [1 : N_j], r \neq u, s \neq v\}$. For all $(ir, js, iu, jv) \in \mathcal{J}$,

$$V_{(ir, js, iu, jv)} = \begin{cases} 1, & \text{if } (\mathbf{X}_{ir}, \mathbf{X}_{js}, \mathbf{X}_{iu}, \mathbf{X}_{jv}) \in T_{X_i X_j X'_i X'_j | X_k}^n(\mathbf{x}_k), \\ 0, & \text{otherwise.} \end{cases}$$

We follow the same analysis as done for (105) to obtain

$$\begin{aligned} &\mathbb{P}\left(|\{(r, s, u, v) \in [1 : N_i] \times [1 : N_j] \times [1 : N_i] \times [1 : N_j] : (\mathbf{X}_{ir}, \mathbf{X}_{js}, \mathbf{X}_{iu}, \mathbf{X}_{jv}) \in T_{X_i X_j X'_i X'_j | X_k}^n, r \neq u, s \neq v\}| \right. \\ &\quad \left. > \max_{\mathcal{S} \subseteq \{1, 2, 3, 4\}} \exp\left\{n\left(g_{X_i, X_j, X'_i, X'_j, X_k}^{\mathcal{S}}(R_i, R_j, R_i, R_j) + \epsilon/2\right)\right\}\right) \\ &\leq (4(N_i + N_j) + 1)^{16} e^{-\exp(n\epsilon/16)/3}. \end{aligned} \tag{120}$$

□

Lemma 13 gives us the following corollary.

Corollary 14. For any $\epsilon > 0$, $n \geq n_0(\epsilon)$, $N_1, N_2, N_3 \geq \exp(n\epsilon)$ and types $P_1 \in \mathcal{P}_{\mathcal{X}_1}^n$, $P_2 \in \mathcal{P}_{\mathcal{X}_2}^n$, $P_3 \in \mathcal{P}_{\mathcal{X}_3}^n$, there exists codebooks $\{\mathbf{x}_{11}, \dots, \mathbf{x}_{1N_1} \in \mathcal{X}_1^n\}$, $\{\mathbf{x}_{21}, \dots, \mathbf{x}_{2N_2} \in \mathcal{X}_2^n\}$, $\{\mathbf{x}_{31}, \dots, \mathbf{x}_{3N_3} \in \mathcal{X}_3^n\}$ whose codewords are of type P_1, P_2, P_3 respectively such that for every permutation (i, j, k) of $(1, 2, 3)$; for every $(\mathbf{x}_i, \mathbf{x}_j, \mathbf{x}_k) \in \mathcal{X}_i^n \times \mathcal{X}_j^n \times \mathcal{X}_k^n$; for every joint type $P_{X_i X'_i X_j X'_j X_k X'_k} \in \mathcal{P}_{\mathcal{X}_i \times \mathcal{X}_i \times \mathcal{X}_j \times \mathcal{X}_j \times \mathcal{X}_k \times \mathcal{X}_k}^n$; and for $R_i \stackrel{\text{def}}{=} (1/n) \log_2 N_i$, $R_j \stackrel{\text{def}}{=} (1/n) \log_2 N_j$, and $R_k \stackrel{\text{def}}{=} (1/n) \log_2 N_k$; the following holds:

$$|\{u \in [1 : N_i] : (\mathbf{x}_{iu}, \mathbf{x}_i, \mathbf{x}_j, \mathbf{x}_k) \in T_{X'_i X_i X_j X_k}^n\}| \leq \exp\left(n\left(|R_1 - I(X'_i; X_1 X_2 X_3)|^+ + \epsilon/2\right)\right); \quad (121)$$

$$\begin{aligned} &|\{(u, v) \in [1 : N_i] \times [1 : N_j] : (\mathbf{x}_{iu}, \mathbf{x}_{jv}, \mathbf{x}_i, \mathbf{x}_j, \mathbf{x}_k) \in T_{X'_i X'_j X_i X_j X_k}^n\}| \\ &\leq \exp\left(n\left(|R_i - I(X'_i; X_i X_j X_k)|^+ + |R_j - I(X'_j; X_i X_j X_k)|^+ - I(X'_i; X'_j | X_i X_j X_k)|^+ + \epsilon/2\right)\right); \end{aligned} \quad (122)$$

$$\begin{aligned} &|\{(u, w) \in [1 : N_i] \times [1 : N_k] : (\mathbf{x}_{iu}, \mathbf{x}_{kw}, \mathbf{x}_i, \mathbf{x}_j, \mathbf{x}_k) \in T_{X'_i X'_j X_i X_j X_k}^n\}| \\ &\leq \exp\left(n\left(|R_i - I(X'_i; X_i X_j X_k)|^+ + |R_k - I(X'_k; X_i X_j X_k)|^+ - I(X'_i; X'_k | X_i X_j X_k)|^+ + \epsilon/2\right)\right); \end{aligned} \quad (123)$$

$$\frac{1}{N_i N_j} |\{(r, s) \in [1 : N_i] \times [1 : N_j] : (\mathbf{x}_{ir}, \mathbf{x}_{js}, \mathbf{x}_k) \in T_{X_i X_j X_k}^n\}| < \exp\left(-\frac{n\epsilon}{2}\right), \text{ if } I(X_i; X_k) + I(X_j; X_i X_k) \geq \epsilon; \quad (124)$$

$$\begin{aligned} &\frac{1}{N_i N_j} |\{(r, s) \in [1 : N_i] \times [1 : N_j] : \exists (u, v) \in [1 : N_i] \times [1 : N_j], u \neq r, v \neq s, (\mathbf{x}_{ir}, \mathbf{x}_{js}, \mathbf{x}_{iu}, \mathbf{x}_{jv}, \mathbf{x}_k) \in T_{X_i X_j X'_i X'_j X_k}^n\}| \\ &< \exp\left(-\frac{n\epsilon}{2}\right), \end{aligned}$$

$$\text{if } I(X_i; X_j X'_i X'_j X_k) + I(X_j; X'_i X'_j X_k) \geq |R_i - I(X'_i; X_k)|^+ + |R_j - I(X'_j; X_k)|^+ - I(X'_i; X'_j | X_k)|^+ + \epsilon; \quad (125)$$

$$\begin{aligned} &\frac{1}{N_i N_j} |\{(r, s) \in [1 : N_i] \times [1 : N_j] : \exists (u, w) \in [1 : N_i] \times [1 : N_k], u \neq r, (\mathbf{x}_{ir}, \mathbf{x}_{js}, \mathbf{x}_{iu}, \mathbf{x}_{kw}, \mathbf{x}_k) \in T_{X_i X_j X'_i X'_j X_k}^n\}| \\ &< \exp\left(-\frac{n\epsilon}{2}\right), \end{aligned}$$

$$\text{if } I(X_i; X_j X'_i X'_j X_k) + I(X_j; X'_i X'_j X_k) \geq |R_i - I(X'_i; X_k)|^+ + |R_k - I(X'_k; X_k)|^+ - I(X'_i; X'_k | X_k)|^+ + \epsilon; \quad (126)$$

$$\begin{aligned} &\frac{1}{N_i N_j} |\{(r, s) \in [1 : N_i] \times [1 : N_j] : \exists u \in [1 : N_i], u \neq r, (\mathbf{x}_{ir}, \mathbf{x}_{js}, \mathbf{x}_{iu}, \mathbf{x}_k) \in T_{X_i X_j X'_i X'_j X_k}^n\}| < \exp\left(-\frac{n\epsilon}{2}\right), \\ &\text{if } I(X_i; X_j X'_i X'_j X_k) + I(X_j; X'_i X'_j X_k) \geq |R_i - I(X'_i; X_k)|^+ + \epsilon. \end{aligned} \quad (127)$$

Proof. Statements (121)-(123) are statements (95), (101) and (102), restated directly from Lemma 13. To show (124), we divide the LHS and RHS of (96) by $N_i N_j$ and substitute the expression for the notation given by (87) to obtain

$$\begin{aligned} &\frac{1}{N_i N_j} |\{(r, s) \in [1 : N_i] \times [1 : N_j] : (\mathbf{x}_{ir}, \mathbf{x}_{js}, \mathbf{x}_k) \in T_{X_i X_j X_k}^n\}| \\ &< \exp\left\{n\left(|R_i - I(X_i; X_k)|^+ + |R_j - I(X_j; X_k)|^+ - I(X_i; X_j | X_k)|^+ + \epsilon/2 - R_i - R_j\right)\right\}. \end{aligned}$$

We will evaluate the RHS for different values of R_i and R_j . We see that when $R_i \leq I(X_i; X_k)$, the RHS is

$$\exp\left\{n\left(|R_j - I(X_j; X_i X_k)|^+ - R_j + \epsilon/2 - R_i\right)\right\}$$

$$\begin{aligned} &\leq \exp\{n(\epsilon/2 - R_i)\} \\ &\stackrel{(a)}{\leq} \exp\{-n\epsilon/2\}, \end{aligned}$$

where (a) holds because $R_i > \epsilon$. Similarly, we can show the same upper bound of $\exp\{n(-\epsilon/2)\}$ when $R_j \leq I(X_j; X_k)$. When $R_i + R_j \leq I(X_i; X_k) + I(X_j; X_k) + I(X_i; X_j|X_k)$, the RHS is upper bounded by $\exp(n(\epsilon/2 - R_i - R_j)) \leq \exp(-n\epsilon/2)$. When $R_i > I(X_i; X_k)$, $R_j > I(X_j; X_k)$ and $R_i + R_j > I(X_i; X_k) + I(X_j; X_k) + I(X_i; X_j|X_k)$, the RHS evaluates to

$$\begin{aligned} &\exp\{n(-I(X_i; X_k) - I(X_j; X_i X_k) + \epsilon/2)\} \\ &\leq \exp\{-n\epsilon/2\}, \quad \text{if } I(X_i; X_k) + I(X_j; X_i X_k) \geq \epsilon. \end{aligned}$$

Next, we will prove (127). For this, we will first show that

$$\frac{1}{N_i N_j} |\{(r, s) \in [1 : N_i] \times [1 : N_j] : \exists u \in [1 : N_i], u \neq r, (\mathbf{x}_{ir}, \mathbf{x}_{js}, \mathbf{x}_{iu}, \mathbf{x}_k) \in T_{X_i X_j X'_i X_k}^n\}| < \exp\left(-\frac{n\epsilon}{2}\right), \quad (128)$$

if any one of the following hold:

$$R_i + R_j - \max_{S \subseteq \{1,2,3\}} g_{X_i, X_j, X'_i, X_k}^S(R_1, R_2, R_1) \geq \epsilon, \quad (129)$$

$$R_i + R_j - \left[|R_i - I(X_i; X_k)|^+ + |R_j - I(X_j; X_k)|^+ - I(X_i; X_j|X_k)\right]^+ \geq \epsilon. \quad (130)$$

We now show that (129) implies (128):

$$\begin{aligned} &\frac{1}{N_i N_j} |\{(r, s) \in [1 : N_i] \times [1 : N_j] : \exists u \in [1 : N_i], u \neq r, (\mathbf{x}_{ir}, \mathbf{x}_{js}, \mathbf{x}_{iu}, \mathbf{x}_k) \in T_{X_i X_j X'_i X_k}^n\}| \\ &\stackrel{(a)}{\leq} \exp\left(-n \left(R_i + R_j - \max_{S \subseteq \{1,2,3\}} g_{X_i, X_j, X'_i, X_k}^S(R_1, R_2, R_1) - \epsilon/2\right)\right) \\ &\leq \exp\left(-\frac{n\epsilon}{2}\right), \quad \text{if } R_i + R_j - \max_{S \subseteq \{1,2,3\}} g_{X_i, X_j, X'_i, X_k}^S(R_1, R_2, R_1) \geq \epsilon, \end{aligned}$$

where (a) follows from (103). Next, we show that (130) implies (128).

$$\begin{aligned} &\frac{1}{N_i N_j} |\{(r, s) \in [1 : N_i] \times [1 : N_j] : \exists u \in [1 : N_i], u \neq r, (\mathbf{x}_{ir}, \mathbf{x}_{js}, \mathbf{x}_{iu}, \mathbf{x}_k) \in T_{X_i X_j X'_i X_k}^n\}| \\ &\leq \frac{1}{N_i N_j} |\{(r, s) \in [1 : N_i] \times [1 : N_j] : (\mathbf{x}_{ir}, \mathbf{x}_{js}, \mathbf{x}_k) \in T_{X_i X_j X_k}^n\}| \\ &\stackrel{(a)}{\leq} \exp\left(-n \left(R_i + R_j - \left[|R_i - I(X_i; X_k)|^+ + |R_j - I(X_j; X_k)|^+ - I(X_i; X_j|X_k)\right]^+ - \epsilon/2\right)\right) \\ &\leq \exp\left(-\frac{n\epsilon}{2}\right), \quad \text{if } R_i + R_j - \left[|R_i - I(X_i; X_k)|^+ + |R_j - I(X_j; X_k)|^+ - I(X_i; X_j|X_k)\right]^+ \geq \epsilon, \end{aligned}$$

where (a) follows from (96). Now, we will show that the condition in (127) implies at least one of (129) or (130). We restate the condition in (127) below for quick reference.

$$I(X_i; X_j X'_i X_k) + I(X_j; X'_i X_k) \geq |R_i - I(X'_i; X_k)|^+ + \epsilon \quad (131)$$

To show that (131) implies at least one of (129) or (130), we will do case analysis based on the value of $\hat{S} \stackrel{\text{def}}{=} \operatorname{argmax}_S g_{X_i, X_j, X'_i, X_k}^S(R_i, R_j, R_i)$, the set of maximizers of the expression $g_{X_i, X_j, X'_i, X_k}^S(R_i, R_j, R_i, R_j)$ in (129). Evaluations of $g_{X_i, X_j, X'_i, X_k}^{\tilde{S}}(R_i, R_j, R_i, R_j)$ under different values of \tilde{S} are provided in Table 1. The table also gives the implications when $\tilde{S} \in \operatorname{argmax}_S g_{X_i, X_j, X'_i, X_k}^S(R_i, R_j, R_i)$ in the fourth column. For example, the ⑥ row considers the

case of $\{1, 3\} \in \text{argmax}_{\mathcal{S}} g_{X_i, X_j, X'_i, X_k}^{\mathcal{S}}(R_i, R_j, R_i)$. Under this case, we have, for instance, $g_{X_i, X_j, X'_i, X_k}^{\{1,3\}}(R_i, R_j, R_i) \geq g_{X_i, X_j, X'_i, X_k}^{\{1,2,3\}}(R_i, R_j, R_i)$, i.e., $R_i - I(X_i; X_j X_k) + R_i - I(X'_i; X_i X_j X_k) \geq R_j - I(X_j; X_k) + R_i - I(X_i; X_j X_k) + R_i - I(X'_i; X_i X_j X_k)$. Hence, $R_j \leq I(X_j; X_k)$. This implication is given in the fifth column of the table against the “reason” $\textcircled{6} \geq \textcircled{8}$ where $\textcircled{8}$ is the row corresponding to $\mathcal{S} = \{1, 2, 3\}$. The other implications are also easy to see from the table. Instead of providing all the implications, the table only provide the ones which we will use in the proof of (127).

Case 1: $\tilde{\mathcal{S}} \in \hat{\mathcal{S}}$ such that $|\tilde{\mathcal{S}}| \leq 1$ In this case, (129) holds as $R_i, R_j \geq \epsilon$.

Case 2: $\tilde{\mathcal{S}} \in \hat{\mathcal{S}}$ such that $|\tilde{\mathcal{S}}| = 2$ If $\{1, 2\} \in \hat{\mathcal{S}}$, then it can be seen from the expression of $g_{X_i, X_j, X'_i, X_k}^{\{1,2\}}(R_i, R_j, R_i, R_j)$ from Table 1 that (131) implies (129). If $\{1, 3\} \in \hat{\mathcal{S}}$, then $R_j \leq I(X_j; X_k)$. This implies that the LHS of (130) evaluates to

$$R_i + R_j - |R_i - I(X_i; X_j X_k)|^+$$

which is at least ϵ because $R_j \geq \epsilon$. Thus, (130) holds. Similarly, when $\{2, 3\} \in \hat{\mathcal{S}}$, one can use the fact that $R_i \leq I(X_i; X_k)$ and $R_i \geq \epsilon$ to show that (130) holds.

Case 3: $\tilde{\mathcal{S}} \in \hat{\mathcal{S}}$ such that $|\tilde{\mathcal{S}}| = 3$ In this case, $R_i \geq I(X'_i; X_k)$. Thus, conditions (131) and (129) are same. Thus, (131) implies (129).

Index	$\tilde{\mathcal{S}}$	$g_{X_i, X_j, X'_i, X_k}^{\tilde{\mathcal{S}}}(R_i, R_j, R_i)$	Implications of $\tilde{\mathcal{S}} \in \text{argmax}_{\mathcal{S}} g_{X_i, X_j, X'_i, X_k}^{\mathcal{S}}(R_i, R_j, R_i)$	reasons
$\textcircled{1}$	\emptyset	0		
$\textcircled{2}$	$\{1\}$	$R_i - I(X_i; X_j X'_i X_k)$		
$\textcircled{3}$	$\{2\}$	$R_j - I(X_j; X_i X'_i X_k)$		
$\textcircled{4}$	$\{3\}$	$R_i - I(X'_i; X_i X_j X_k)$		
$\textcircled{5}$	$\{1, 2\}$	$R_i - I(X_i; X'_i X_k) + R_j - I(X_j; X_i X'_i X_k)$		
$\textcircled{6}$	$\{1, 3\}$	$R_i - I(X_i; X_j X_k) + R_i - I(X'_i; X_i X_j X_k)$	$R_j \leq I(X_j; X_k)$	$\textcircled{6} \geq \textcircled{8}$
$\textcircled{7}$	$\{2, 3\}$	$R_j - I(X_j; X_i X_k) + R_i - I(X'_i; X_i X_j X_k)$	$R_i \leq I(X_i; X_k)$	$\textcircled{7} \geq \textcircled{8}$
$\textcircled{8}$	$\{1, 2, 3\}$	$R_i - I(X_i; X_k) + R_j - I(X_j; X_i X_k) + R_i - I(X'_i; X_i X_j X_k)$	$R_i \geq I(X'_i; X_k)$	$\textcircled{8} \geq \textcircled{5}$

Table 1: Table showing different evaluations of $\max_{\mathcal{S} \subseteq \{1,2,3\}} g_{X_i, X_j, X'_i, X_k}^{\mathcal{S}}(R_i, R_j, R_i)$ and their implications.

Now, We will now show (125). Its proof is very similar to the proof of (127). To show (125), we will first show that

$$\frac{1}{N_i N_j} |\{(r, s) \in [1 : N_i] \times [1 : N_j] : \exists (u, v) \in [1 : N_i] \times [1 : N_j], u \neq r, v \neq s, (\mathbf{x}_{ir}, \mathbf{x}_{js}, \mathbf{x}_{iu}, \mathbf{x}_{jv}, \mathbf{x}_k) \in T_{X_i X_j X'_i X'_j X_k}^n\}| < \exp\left(-\frac{n\epsilon}{2}\right) \quad (132)$$

if any one of the following inequalities hold:

$$R_i + R_j - \max_{\mathcal{S} \subseteq \{1,2,3,4\}} g_{X_i, X_j, X'_i, X_k}^{\mathcal{S}}(R_i, R_j, R_i, R_j) \geq \epsilon, \quad (133)$$

$$R_j - \left| |R_j - I(X_j; X_k)|^+ + |R_i - I(X'_i; X_k)|^+ - I(X_j; X'_i | X_k) \right|^+ \geq \epsilon, \quad (134)$$

$$R_j - \left| |R_j - I(X_j; X_k)|^+ + |R_j - I(X'_i; X_k)|^+ - I(X_j; X'_i | X_k) \right|^+ \geq \epsilon, \quad (135)$$

$$R_i - \left| |R_i - I(X_i; X_k)|^+ + |R_i - I(X'_i; X_k)|^+ - I(X_i; X'_i|X_k) \right|^+ \geq \epsilon, \quad (136)$$

$$R_i - \left| |R_i - I(X_i; X_k)|^+ + |R_j - I(X'_j; X_k)|^+ - I(X_i; X'_j|X_k) \right|^+ \geq \epsilon, \quad (137)$$

$$R_i + R_j - \left| |R_i - I(X_i; X_k)|^+ + |R_j - I(X_j; X_k)|^+ - I(X_i; X_j|X_k) \right|^+ \geq \epsilon. \quad (138)$$

The fact that (133) implies (132) can be shown as follows:

$$\begin{aligned} & \frac{1}{N_i N_j} |\{(r, s) \in [1 : N_i] \times [1 : N_j] : \exists (u, v) \in [1 : N_i] \times [1 : N_j], u \neq r, v \neq s, (\mathbf{x}_{ir}, \mathbf{x}_{js}, \mathbf{x}_{iu}, \mathbf{x}_{jv}, \mathbf{x}_k) \in T_{X_i X_j X'_i X'_j X_k}^n\}| \\ & \leq \frac{1}{N_i N_j} |\{(r, s, u, v) \in [1 : N_i] \times [1 : N_j] \times [1 : N_i] \times [1 : N_j] : u \neq r, v \neq s, (\mathbf{x}_{ir}, \mathbf{x}_{js}, \mathbf{x}_{iu}, \mathbf{x}_{jv}, \mathbf{x}_k) \in T_{X_i X_j X'_i X'_j X_k}^n\}| \\ & \stackrel{(a)}{\leq} \exp\left(-n \left(R_i + R_j - \max_{S \in \{1, 2, 3, 4\}} g_{X_i, X_j, X'_i, X'_j, X_k}^S(R_i, R_j, R_i, R_j) - \epsilon/2\right)\right) \\ & \leq \exp(-n\epsilon/2), \quad \text{if } R_i + R_j - g_{X_i, X_j, X'_i, X'_j, X_k}^S(R_i, R_j, R_i, R_j) \geq \epsilon, \end{aligned}$$

where (a) uses (104). Next we show that (134) implies (132).

$$\begin{aligned} & \frac{1}{N_i N_j} |\{(r, s) \in [1 : N_i] \times [1 : N_j] : \exists (u, v) \in [1 : N_i] \times [1 : N_j], u \neq r, v \neq s, (\mathbf{x}_{ir}, \mathbf{x}_{js}, \mathbf{x}_{iu}, \mathbf{x}_{jv}, \mathbf{x}_k) \in T_{X_i X_j X'_i X'_j X_k}^n\}| \\ & \leq \frac{1}{N_i N_j} |\{(r, s, u) \in [1 : N_i] \times [1 : N_j] \times [1 : N_i] : (\mathbf{x}_{js}, \mathbf{x}_{iu}, \mathbf{x}_k) \in T_{X_j X'_i X_k}^n\}| \\ & = \frac{1}{N_i N_j} |\{r \in [1 : N_i]\} \times \{(s, u) \in [1 : N_j] \times [1 : N_i] : (\mathbf{x}_{js}, \mathbf{x}_{iu}, \mathbf{x}_k) \in T_{X_j X'_i X_k}^n\}| \\ & = \frac{1}{N_j} |\{(s, u) \in [1 : N_j] \times [1 : N_i] : (\mathbf{x}_{js}, \mathbf{x}_{iu}, \mathbf{x}_k) \in T_{X_j X'_i X_k}^n\}| \\ & \stackrel{(a)}{\leq} \exp\left(-n \left(R_j - \left| |R_j - I(X_j; X_k)|^+ + |R_i - I(X'_i; X_k)|^+ - I(X_j; X'_i|X_k) \right|^+ - \epsilon/2\right)\right) \\ & \leq \exp(-n\epsilon/2), \quad \text{if } R_j - \left| |R_j - I(X_j; X_k)|^+ + |R_i - I(X'_i; X_k)|^+ - I(X_j; X'_i|X_k) \right|^+ \geq \epsilon. \end{aligned}$$

Here (a) uses (97) with X_i replaced with X'_i . The remaining conditions can also be obtained similarly. We can show that (135) implies (132) by using (98) on the following upper bound.

$$\begin{aligned} & \frac{1}{N_i N_j} |\{(r, s) \in [1 : N_i] \times [1 : N_j] : \exists (u, v) \in [1 : N_i] \times [1 : N_j], u \neq r, v \neq s, (\mathbf{x}_{ir}, \mathbf{x}_{js}, \mathbf{x}_{iu}, \mathbf{x}_{jv}, \mathbf{x}_k) \in T_{X_i X_j X'_i X'_j X_k}^n\}| \\ & \leq \frac{1}{N_i N_j} |\{(r, s, v) \in [1 : N_i] \times [1 : N_j] \times [1 : N_j] : s \neq v, (\mathbf{x}_{js}, \mathbf{x}_{jv}, \mathbf{x}_k) \in T_{X_j X'_j X_k}^n\}| \\ & = \frac{1}{N_j} |\{(s, v) \in [1 : N_j] \times [1 : N_j] : s \neq v, (\mathbf{x}_{js}, \mathbf{x}_{jv}, \mathbf{x}_k) \in T_{X_j X'_j X_k}^n\}|. \end{aligned}$$

To show that (136) implies (132), we use the following upper bound and (97).

$$\begin{aligned} & \frac{1}{N_i N_j} |\{(r, s) \in [1 : N_i] \times [1 : N_j] : \exists (u, v) \in [1 : N_i] \times [1 : N_j], u \neq r, v \neq s, (\mathbf{x}_{ir}, \mathbf{x}_{js}, \mathbf{x}_{iu}, \mathbf{x}_{jv}, \mathbf{x}_k) \in T_{X_i X_j X'_i X'_j X_k}^n\}| \\ & \leq \frac{1}{N_i N_j} |\{(r, s, u) \in [1 : N_i] \times [1 : N_j] \times [1 : N_i] : r \neq u, (\mathbf{x}_{ir}, \mathbf{x}_{iu}, \mathbf{x}_k) \in T_{X_i X'_i X_k}^n\}| \\ & = \frac{1}{N_i} |\{(r, u) \in [1 : N_i] \times [1 : N_i] : r \neq u, (\mathbf{x}_{ir}, \mathbf{x}_{iu}, \mathbf{x}_k) \in T_{X_i X'_i X_k}^n\}|. \end{aligned}$$

The condition (137) can be obtained similarly by using (97) (with X_j replaced with X'_j) on the following upper bound:

$$\begin{aligned} & \frac{1}{N_i N_j} |\{(r, s) \in [1 : N_i] \times [1 : N_j] : \exists (u, v) \in [1 : N_i] \times [1 : N_j], u \neq r, v \neq s, (\mathbf{x}_{ir}, \mathbf{x}_{js}, \mathbf{x}_{iu}, \mathbf{x}_{jv}, \mathbf{x}_k) \in T_{X_i X_j X'_i X'_j X_k}^n\}| \\ & \leq \frac{1}{N_i N_j} |\{(r, s, v) \in [1 : N_i] \times [1 : N_j] \times [1 : N_j] : (\mathbf{x}_{ir}, \mathbf{x}_{jv}, \mathbf{x}_k) \in T_{X_i X'_j X_k}^n\}| \\ & = \frac{1}{N_i} |\{(r, v) \in [1 : N_i] \times [1 : N_j] : (\mathbf{x}_{ir}, \mathbf{x}_{jv}, \mathbf{x}_k) \in T_{X_i X'_j X_k}^n\}|. \end{aligned}$$

For (138), we use (96) on the following upper bound:

$$\begin{aligned} & \frac{1}{N_i N_j} |\{(r, s) \in [1 : N_i] \times [1 : N_j] : \exists (u, v) \in [1 : N_i] \times [1 : N_j], u \neq r, v \neq s, (\mathbf{x}_{ir}, \mathbf{x}_{js}, \mathbf{x}_{iu}, \mathbf{x}_{jv}, \mathbf{x}_k) \in T_{X_i X_j X'_i X'_j X_k}^n\}| \\ & \leq \frac{1}{N_i N_j} |\{(r, s) \in [1 : N_i] \times [1 : N_j] : (\mathbf{x}_{ir}, \mathbf{x}_{js}, \mathbf{x}_k) \in T_{X_i X_j X_k}^n\}|. \end{aligned}$$

Now to show (125), we will show that the condition in (125) implies at least one of (133)-(137). We restate the condition in (125) below for quick reference.

$$I(X_i; X_j X'_i X'_j X_k) + I(X_j; X'_i X'_j X_k) \geq \left| |R_i - I(X'_i; X_k)|^+ + |R_j - I(X'_j; X_k)|^+ - I(X'_i; X'_j | X_k) \right|^+ + \epsilon. \quad (139)$$

To show that (139) implies at least one of (133)-(137), we do a case analysis similar to the one in proof of (127). The case analysis will be based on the value of $\hat{\mathcal{S}} \stackrel{\text{def}}{=} \text{argmax}_{\mathcal{S}} g_{X_i, X_j, X'_i, X'_j, X_k}^{\mathcal{S}}(R_i, R_j, R_i, R_j)$, the set of maximizers of the expression $g_{X_i, X_j, X'_i, X'_j, X_k}^{\mathcal{S}}(R_i, R_j, R_i, R_j)$ in (133). For ease of reference, evaluations of the expression $g_{X_i, X_j, X'_i, X'_j, X_k}^{\tilde{\mathcal{S}}}(R_i, R_j, R_i, R_j)$ under different values of $\tilde{\mathcal{S}}$ are given in Table 2. Table 2 is similar to Table 1. It also gives the implications when $\tilde{\mathcal{S}} \in \text{argmax}_{\mathcal{S} \subseteq \{1, 2, 3, 4\}} g_{X_i, X_j, X'_i, X'_j, X_k}^{\tilde{\mathcal{S}}}(R_i, R_j, R_i, R_j)$ in the fourth column. For example, the ⑨-th row considers the case of $\{2, 3\} \in \text{argmax}_{\mathcal{S}} g_{X_i, X_j, X'_i, X'_j, X_k}^{\tilde{\mathcal{S}}}(R_i, R_j, R_i, R_j)$. Under this case, $g_{X_i, X_j, X'_i, X'_j, X_k}^{\{2, 3\}}(R_i, R_j, R_i, R_j) \geq g_{X_i, X_j, X'_i, X'_j, X_k}^{\{1, 2, 3\}}(R_i, R_j, R_i, R_j)$, i.e. $R_j - I(X_j; X_i X'_j X_k) + R_i - I(X'_i; X_i X_j X'_j X_k) \geq R_i - I(X_i; X'_j X_k) + R_j - I(X_j; X_i X'_j X_k) + R_i - I(X'_i; X_i X_j X'_j X_k)$. This implies that $R_i \leq I(X_i; X'_j X_k)$. It is given in the fifth column of the table against the “reason” ⑨ \geq ⑮ where ⑮ is the row corresponding to $\mathcal{S} = \{1, 2, 3\}$. The other implications can also be seen easily from the table.

Case 1: $\tilde{\mathcal{S}} \in \hat{\mathcal{S}}$ such that $|\tilde{\mathcal{S}}| \leq 1$ For this case, substituting the expression of $g_{X_i, X_j, X'_i, X'_j, X_k}^{\tilde{\mathcal{S}}}(R_i, R_j, R_i, R_j)$ from Table 2 and noting $R_i, R_j \geq \epsilon$, we see that (133) holds.

Case 2: $\tilde{\mathcal{S}} \in \hat{\mathcal{S}}$ such that $|\tilde{\mathcal{S}}| = 2$ We start with $\{1, 2\} \in \hat{\mathcal{S}}$. For this case, (133) evaluates to $I(X_i; X'_i X'_j X_k) + I(X_i; X'_i X'_j X_j X_k) \geq \epsilon$ which is directly implied by (139). If $\{1, 3\} \in \hat{\mathcal{S}}$, we see from Table 2 that $R_j \leq I(X_j; X'_j X_k)$, $R_j \leq I(X'_j; X_j X_k)$ and $R_j - I(X_j; X_k) + R_j - I(X'_j; X_k) - I(X_j; X'_j | X_k) \leq 0$. This implies that $\left| |R_j - I(X_j; X_k)|^+ + |R_j - I(X'_j; X_k)|^+ - I(X_j; X'_j | X_k) \right|^+ = 0$. Thus, by noting that $R_j \geq \epsilon$, (135) holds. Similarly; if $\{1, 4\} \in \hat{\mathcal{S}}$, (134) holds; if $\{2, 3\} \in \hat{\mathcal{S}}$, (137) holds; if $\{2, 4\} \in \hat{\mathcal{S}}$, (136) holds; and if $\{3, 4\} \in \hat{\mathcal{S}}$, (138) holds.

Case 3: $\tilde{\mathcal{S}} \in \hat{\mathcal{S}}$ such that $|\tilde{\mathcal{S}}| = 3$ If $\{2, 3, 4\} \in \hat{\mathcal{S}}$, from Table 2, $R_i \leq I(X_i; X_k)$. This implies that the LHS of (138) is $R_i + R_j - |R_j - I(X_j; X_i X_k)|^+$ which is at least ϵ because $R_i \geq \epsilon$. Thus, (138) holds. Similarly, for

$\{1, 3, 4\} \in \hat{\mathcal{S}}$, $R_j \leq I(X_j; X_k)$, which implies that (138) holds. If $\{1, 2, 4\} \in \hat{\mathcal{S}}$, from Table 2, $R_i \leq I(X'_i; X_k)$ and $R_j \geq I(X'_j; X'_i X_k)$. These imply that (139) evaluates to

$$I(X_i; X_j X'_i X'_j X_k) + I(X_j; X'_i X'_j X_k) \geq R_j - I(X'_j; X'_i X_k) + \epsilon.$$

Moreover, since $\{1, 2, 4\} \in \hat{\mathcal{S}}$, (133) evaluates to

$$R_i + R_j - (R_i - I(X_i; X'_j X_k) + R_j - I(X_j; X_i X'_j X_k) + R_j - I(X'_j; X_i X_j X'_i X_k)) \geq \epsilon.$$

It can be seen upon rearranging that (139) and (133) are the same. Thus, (139) implies (133). Similarly, for $\mathcal{S} = \{1, 2, 3\}$, (139) evaluates to

$$I(X_i; X_j X'_i X'_j X_k) + I(X_j; X'_i X'_j X_k) \geq R_i - I(X'_i; X'_j X_k) + \epsilon.$$

which implies (133).

For $\mathcal{S} = \{1, 2, 3\}$, $R_j \leq I(X'_j; X_k)$ and $R_i \geq I(X'_i; X'_j X_k)$. This implies that (139) evaluates to

$$I(X_i; X_j X'_i X'_j X_k) + I(X_j; X'_i X'_j X_k) \geq R_i - I(X'_i; X'_j X_k) + \epsilon.$$

and for $\mathcal{S} = \{1, 2, 3\}$, (133) evaluates to

$$R_i + R_j - (R_i - I(X_i; X'_j X_k) + R_j - I(X_j; X_i X'_j X_k) + R_i - I(X'_i; X_i X_j X'_i X_k)) \geq \epsilon.$$

It can be seen upon rearranging that the above two inequalities are the same. Thus, (139) implies (133) if $\{1, 2, 4\} \in \hat{\mathcal{S}}$. Similarly, for $\mathcal{S} = \{1, 2, 4\}$, (139) evaluates to

$$I(X_i; X_j X'_i X'_j X_k) + I(X_j; X'_i X'_j X_k) \geq R_j - I(X'_j; X'_i X_k) + \epsilon$$

which implies (133).

Case 4: $\tilde{\mathcal{S}} \in \hat{\mathcal{S}}$ such that $|\tilde{\mathcal{S}}| = 4$ For $\{1, 2, 3, 4\} \in \hat{\mathcal{S}}$, (139) evaluates to

$$I(X_i; X_j X'_i X'_j X_k) + I(X_j; X'_i X'_j X_k) \geq R_j - I(X'_j; X_k) + R_i - I(X'_i; X'_j X_k) + \epsilon$$

and (133) evaluates to

$$R_i + R_j - 2R_i - 2R_j + I(X'_j; X_k) + I(X'_i; X'_j X_k) + I(X_j; X'_i X'_j X_k) + I(X_i; X_j X'_i X'_j X_k) \geq \epsilon$$

which is same as (139). Thus, (139) implies (133).

Statement (126) can be proved similarly by using (96), (97), (99), (100) and (105), the equivalent statements of (96)-(98) and (104) on replacing \mathbf{x}_{jv} , X'_j and the corresponding rate R_j with \mathbf{x}_{kw} , X'_k and the corresponding rate R_k respectively. In fact, by making these replacements in the proof of (125), we obtain the proof of (126). Note that the proof of (125) only depended on (96)-(98) and (104). □

C Proof of Lemma 6

Proof of Lemma 6.

$$P_{e, \mathcal{Q}} = \max_{\mathbf{x}_{\mathcal{Q}}} \frac{1}{\left(\prod_{i \in \mathcal{Q}^c} N_i\right)} \sum_{m_{\mathcal{Q}^c} \in \mathcal{M}_{\mathcal{Q}^c}} \mathbb{P}(\{\phi(\mathbf{Y})_{\mathcal{Q}^c} \neq m_{\mathcal{Q}^c}\} | \mathbf{X}_{\mathcal{Q}^c} = f_{\mathcal{Q}^c}(m_{\mathcal{Q}^c}), \mathbf{X}_{\mathcal{Q}} = \mathbf{x}_{\mathcal{Q}})$$

Index	\tilde{S}	$g_{X_i, X_j, X'_i, X'_j, X_k}^{\tilde{S}}(R_i, R_j, R_i, R_j)$	Implications of $\tilde{S} \in \operatorname{argmax}_{S} g_{X_i, X_j, X'_i, X'_j, X_k}^S(R_i, R_j, R_i, R_j)$	reasons
①	\emptyset	0		
②	{1}	$R_i - I(X_i; X_j X'_i X'_j X_k)$		
③	{2}	$R_j - I(X_j; X_i X'_i X'_j X_k)$		
④	{3}	$R_i - I(X'_i; X_i X_j X'_j X_k)$		
⑤	{4}	$R_j - I(X'_j; X_i X_j X'_i X_k)$		
⑥	{1, 2}	$R_i - I(X_i; X'_i X'_j X_k) + R_j - I(X_j; X_i X'_i X'_j X_k)$		
⑦	{1, 3}	$R_i - I(X_i; X_j X'_j X_k) + R_i - I(X'_i; X_i X_j X'_j X_k)$	$R_j \leq I(X_j; X'_j X_k)$	(7) \geq (15)
			$R_j \leq I(X'_j; X_j X_k)$	(7) \geq (13)
			$R_j - I(X_j; X_k) + R_j - I(X'_j; X_j X_k) \leq 0$	(7) \geq (16)
⑧	{1, 4}	$R_i - I(X_i; X_j X'_j X_k) + R_j - I(X'_j; X_i X_j X'_i X_k)$	$R_j \leq I(X_j; X'_j X_k)$	(8) \geq (14)
			$R_i \leq I(X'_i; X_j X_k)$	(8) \geq (13)
			$R_j - I(X_j; X_k) + R_i - I(X'_i; X_j X_k) \leq 0$	(8) \geq (16)
⑨	{2, 3}	$R_j - I(X_j; X_i X'_i X_k) + R_i - I(X'_i; X_i X_j X'_j X_k)$	$R_i \leq I(X_i; X'_i X_k)$	(9) \geq (15)
			$R_j \leq I(X'_j; X_i X_k)$	(9) \geq (12)
			$R_i - I(X_i; X_k) + R_j - I(X'_j; X_i X_k) \leq 0$	(9) \geq (16)
⑩	{2, 4}	$R_j - I(X_j; X_i X'_i X_k) + R_j - I(X'_j; X_i X_j X'_i X_k)$	$R_i \leq I(X_i; X'_i X_k)$	(10) \geq (14)
			$R_i \leq I(X'_i; X_i X_k)$	(10) \geq (12)
			$R_i - I(X_i; X_k) + R_i - I(X'_i; X_i X_k) \leq 0$	(10) \geq (16)
⑪	{3, 4}	$R_i - I(X'_i; X_i X_j X_k) + R_j - I(X'_j; X_i X_j X'_i X_k)$	$R_i \leq I(X_i; X_j X_k)$	(11) \geq (13)
			$R_j \leq I(X'_j; X_i X_k)$	(11) \geq (12)
			$R_i - I(X_i; X_k) + R_i - I(X_j; X_i X_k) \leq 0$	(11) \geq (16)
⑫	{2, 3, 4}	$R_j - I(X_j; X_i X_k) + R_i - I(X'_i; X_i X_j X_k) + R_j - I(X'_j; X_i X_j X'_i X_k)$	$R_i \leq I(X_i; X_k)$	(12) \geq (16)
⑬	{1, 3, 4}	$R_i - I(X_i; X_j X_k) + R_i - I(X'_i; X_i X_j X_k) + R_j - I(X'_j; X_i X_j X'_i X_k)$	$R_j \leq I(X_j; X_k)$	(13) \geq (16)
⑭	{1, 2, 4}	$R_i - I(X_i; X'_i X_k) + R_j - I(X_j; X_i X'_i X_k) + R_j - I(X'_j; X_i X_j X'_i X_k)$	$R_i \leq I(X'_i; X_k)$	(14) \geq (16)
			$R_j \geq I(X'_j; X'_i X_k)$	(14) \geq (6)
⑮	{1, 2, 3}	$R_i - I(X_i; X'_j X_k) + R_j - I(X_j; X_i X'_j X_k) + R_i - I(X'_i; X_i X_j X'_j X_k)$	$R_j \leq I(X'_j; X_k)$	(15) \geq (16)
			$R_i \geq I(X'_i; X'_j X_k)$	(15) \geq (6)
⑯	{1, 2, 3, 4}	$R_i - I(X_i; X_k) + R_j - I(X_j; X_i X_k) + R_i - I(X'_i; X_i X_j X_k) + R_j - I(X'_j; X'_i X_i X_j X_k)$	$R_i \geq I(X'_i; X_k)$	(16) \geq (14)
			$R_j \geq I(X'_j; X_k)$	(16) \geq (15)
			$R_i - I(X'_i; X_k) + R_j - I(X'_j; X'_i; X_k) \geq 0$	(16) \geq (6)

Table 2: Table showing different evaluations of $\max_{S \subseteq \{1,2,3,4\}} g_{X_i, X_j, X'_i, X'_j, X_k}^S(R_i, R_j, R_i, R_j)$ and their implications.

$$\begin{aligned}
&= \max_{\mathbf{x}_{\mathcal{Q}}} \frac{1}{\left(\prod_{i \in \mathcal{Q}^c} N_i\right)} \sum_{m_{\mathcal{Q}^c} \in \mathcal{M}_{\mathcal{Q}^c}} \mathbb{P}(\cup_{i=1}^t \{\phi(\mathbf{Y})_{\mathcal{Q}_i^c} \neq m_{\mathcal{Q}_i^c}\} | \mathbf{X}_{\mathcal{Q}^c} = f_{\mathcal{Q}^c}(m_{\mathcal{Q}^c}), \mathbf{X}_{\mathcal{Q}} = \mathbf{x}_{\mathcal{Q}}) \\
&\leq \max_{\mathbf{x}_{\mathcal{Q}}} \frac{1}{\left(\prod_{i \in \mathcal{Q}^c} N_i\right)} \sum_{m_{\mathcal{Q}^c} \in \mathcal{M}_{\mathcal{Q}^c}} \sum_{i=1}^t \mathbb{P}(\{\phi(\mathbf{Y})_{\mathcal{Q}_i^c} \neq m_{\mathcal{Q}_i^c}\} | \mathbf{X}_{\mathcal{Q}^c} = f_{\mathcal{Q}^c}(m_{\mathcal{Q}^c}), \mathbf{X}_{\mathcal{Q}} = \mathbf{x}_{\mathcal{Q}}) \\
&\leq \sum_{i=1}^t \max_{\mathbf{x}_{\mathcal{Q}_i}} \frac{1}{\left(\prod_{i \in \mathcal{Q}^c} N_i\right)} \sum_{m_{\mathcal{Q}^c} \in \mathcal{M}_{\mathcal{Q}^c}} \mathbb{P}(\{\phi(\mathbf{Y})_{\mathcal{Q}_i^c} \neq m_{\mathcal{Q}_i^c}\} | \mathbf{X}_{\mathcal{Q}^c} = f_{\mathcal{Q}^c}(m_{\mathcal{Q}^c}), \mathbf{X}_{\mathcal{Q}_i} = \mathbf{x}_{\mathcal{Q}_i}) \\
&= \sum_{i=1}^t \max_{\mathbf{x}_{\mathcal{Q}_i}} \frac{1}{\left(\prod_{i \in \mathcal{Q}^c} N_i\right)} \sum_{m_{\mathcal{Q}^c} \in \mathcal{M}_{\mathcal{Q}^c}} \mathbb{P}(\{\phi(\mathbf{Y})_{\mathcal{Q}_i^c} \neq m_{\mathcal{Q}_i^c}\} | \mathbf{X}_{\mathcal{Q}^c} = f_{\mathcal{Q}^c}(m_{\mathcal{Q}^c}), \mathbf{X}_{\mathcal{Q}_i} = \mathbf{x}_{\mathcal{Q}_i}) \\
&= \sum_{i=1}^t P_{e, \mathcal{Q}_i}.
\end{aligned}$$

□

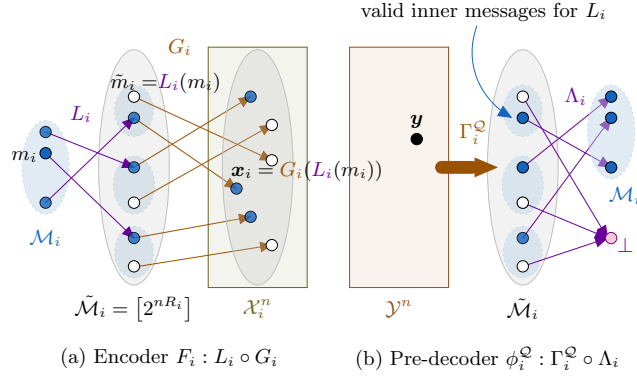

Figure 14: The encoders and pre-decoders for Theorem 7.

D Proof of achievability of Theorem 7

For the achievability, we will require the following theorem which gives the randomized coding capacity region of a t -user AV-MAC $W_{Y|X_1, \dots, X_t, S}$ where \mathcal{X}_i , $i \in [1 : k]$ are the input alphabets and \mathcal{Y} and \mathcal{S} are the output and the state alphabets respectively. The theorem can be proved along the lines of the two user result given in [8]. In particular, see [8, Remark IIA3].

Theorem 15 (AV-MAC randomized capacity region for t -users). The randomized capacity region of the AV-MAC $W_{Y|X_1, \dots, X_t, S}$ is the set of rate tuples such that

$$\sum_{j \in \mathcal{J}} R_j \leq \min_{q(s|u)} I(X_{\mathcal{J}}; Y | X_{\mathcal{J}^c}, S) \text{ for every } \mathcal{J} \subseteq [1 : t]$$

for some joint distribution $p(u)q(s|u) \prod_{i=1}^t p(x_i|u)$ with $|\mathcal{U}| \leq t$.

Proof (Achievability of Theorem 7). This proof is along the lines of the proof of Theorem 3. For each $\mathcal{Q} \in \mathcal{A}$, let $W^{\mathcal{Q}}$ be the $|\mathcal{Q}^c|$ -user AV-MAC which corresponds to users in the set \mathcal{Q} as adversary and the users in the set \mathcal{Q}^c as the legitimate users. For users in \mathcal{Q} , their combined input $\mathbf{x}_{\mathcal{Q}}$ and the product input alphabet $\times_{i \in \mathcal{Q}} \mathcal{X}_i$ correspond to the adversarial state input and the state alphabet respectively. Let (R_1, R_2, \dots, R_k) be a rate tuple such that for some $p(u) \cdot p(x_1|u) \cdot p(x_2|u) \cdot \dots \cdot p(x_k|u)$, the following conditions hold for all $\mathcal{Q} \in \mathcal{A}$ and $\mathcal{J} \subseteq \mathcal{Q}^c$,

$$\sum_{j \in \mathcal{J}} R_j \leq \min_{q_{\mathcal{Q}}(\mathbf{x}_{\mathcal{Q}}|u)} I(X_{\mathcal{J}}; Y | X_{(\mathcal{Q} \cup \mathcal{J})^c}) \quad (140)$$

where the mutual information above is evaluated using the joint distribution $p(u)q(\mathbf{x}_{\mathcal{Q}}|u) \prod_{j \in \mathcal{J}} p(x_j|u)W(y|\mathbf{x}_{\mathcal{Q}}, \mathbf{x}_{\mathcal{Q}^c})$. Here $|\mathcal{U}| \leq k$. Let $\epsilon > 0$ be arbitrary and let n be large enough. Note that, by Theorem 15, the rate tuple $R_{\mathcal{Q}^c}$ is an achievable rate pair for the AVMAC $W^{\mathcal{Q}}$. For each $i \in [1 : k]$, let $\tilde{\mathcal{M}}_i = [1 : 2^{nR_i}]$ and $\mathcal{M}_i = [1 : 2^{nR_i}/v]$ for the largest integer $v \leq (k|\mathcal{A}|)/\epsilon$. In the following, we show the existence of a randomized $(2^{nR_1}/v, \dots, 2^{nR_k}/v, n)$ code (F_1, \dots, F_k, ϕ) with P_e^{strong} no larger than ϵ , for sufficiently large n .

Code design Before describing the code, we describe the following maps which will help in describing the encoders and the decoder (see Figure 14). For each user i , let $G_i : \tilde{\mathcal{M}}_i \rightarrow \mathcal{X}_i^n$ be a randomized map such that it maps $m_i \in \tilde{\mathcal{M}}_i$ to an n -length i.i.d. sequence $G_i(m_i)$ generated according to the distribution p_i . The sequences $G_i(m)$ are independent across $i \in [1 : k]$ and $m \in \mathcal{M}_i$. The realization of $G_i(m_i)$ for all $i \in [1 : k]$ and $m_i \in \mathcal{M}_i$ is shared with the decoder. For any $\mathcal{Q} \in \mathcal{A}$, consider the $|\mathcal{Q}^c|$ -user AV-MAC $W^{\mathcal{Q}}$ as described above. For each $i \in \mathcal{Q}^c$, if we consider $\tilde{\mathcal{M}}_i$ as the message set and G_i as the corresponding encoder, then this construction ensures that the

random encoders $G_i, i \in \mathcal{Q}^c$ are independent and their randomness is also private from the adversarial users in the set \mathcal{Q} . Thus, the joint distribution of the encoders $G_i, i \in \mathcal{Q}^c$ (and the corresponding codewords) is the same as that of the encoders of AV-MAC $W^{\mathcal{Q}}$ in the direct part of [8, Theorem 1, Section III-C] (and its extension to a t -user AV-MAC as in Theorem 15). For $G_i, i \in \mathcal{Q}^c$ as encoders, let $\Gamma^{\mathcal{Q}}$ denote the corresponding decoder for the AV-MAC $W^{\mathcal{Q}}$ in Theorem 15. Suppose $(\Gamma_j^{\mathcal{Q}}, j \in \mathcal{Q}^c) := \Gamma^{\mathcal{Q}}$ where $\Gamma_j^{\mathcal{Q}} : \mathcal{Y}^n \rightarrow \tilde{\mathcal{M}}_i$. For all $\epsilon > 0$, by Theorem 15, there exists a large enough n such that for all $\mathcal{Q} \in \mathcal{A}$, the code $((G_i, i \in \mathcal{Q}^c), \Gamma^{\mathcal{Q}})$ has error probability no larger than $\epsilon/(k|\mathcal{A}|)$. We consider that n .

For each $i \in [1 : k]$, the message set \mathcal{M}_i is randomly embedded into the set $\tilde{\mathcal{M}}_i$ as follows: We choose an arbitrary partition of $\tilde{\mathcal{M}}_i$ into $|\mathcal{M}_i|$ many disjoint equal-sized subsets (each subset size is v). Let us denote the partition by $\mathcal{S}_{m_i}, m_i \in \mathcal{M}_i$ where $\cup_{m_i \in \mathcal{M}_i} \mathcal{S}_{m_i} = \tilde{\mathcal{M}}_i$ and $\mathcal{S}_{m_i} \cap \mathcal{S}_{m'_i} = \emptyset$ for all $m_i \neq m'_i, m_i, m'_i \in \mathcal{M}_i$. The size of each $\mathcal{S}_{m_i}, m_i \in \mathcal{M}_i$ is $v (\leq k|\mathcal{A}|/\epsilon)$. The maps $L_i : \mathcal{M}_i \rightarrow \tilde{\mathcal{M}}_i$ and $\Lambda_i : \tilde{\mathcal{M}}_i \rightarrow \mathcal{M}_i$ are the forward and reverse maps for an injection from \mathcal{M}_i to $\tilde{\mathcal{M}}_i$ where, independently for each $m_i \in \mathcal{M}_i$, $L_i(m_i)$ is chosen uniformly at random from \mathcal{S}_{m_i} . Both the encoder maps G_i and L_i are independent for $i = 1, 2, \dots, k$ and are made available to the decoder as the shared secret between user- i and the decoder, unknown to other users.

For the code of the byzantine-MAC, for each $i \in [1 : k]$, the encoder map $F_i : \mathcal{M}_i \rightarrow \mathcal{X}_i^n$ is defined as $F_i(m_i) = G_i(L_i(m_i))$ for every $m_i \in \mathcal{M}_i$. For each $\mathcal{Q} \in \mathcal{A}$ and $i \in \mathcal{Q}^c$, we define pre-decoder¹¹

$$\phi_i^{\mathcal{Q}}(\mathbf{y}) = \begin{cases} \Lambda_i(\Gamma_i^{\mathcal{Q}}(\mathbf{y})) & \text{if } \Gamma_i^{\mathcal{Q}}(\mathbf{y}) \in L_i(\mathcal{M}_i), \\ \perp & \text{otherwise.} \end{cases}$$

The decoder $\phi : \mathcal{Y}^n \rightarrow \times_{i \in [1:k]} \mathcal{M}_i$ outputs $\phi(\mathbf{y}) = (\hat{m}_1, \dots, \hat{m}_k)$, where, for each $i \in [1 : k]$ and $\mathcal{Q} \in \mathcal{A}$,

$$\hat{m}_i = \begin{cases} \phi_i^{\mathcal{Q}}(\mathbf{y}) & \text{if } |\{\phi_i^{\tilde{\mathcal{Q}}}(\mathbf{y}) : \tilde{\mathcal{Q}} \in \mathcal{A}\}| = 1 \text{ and } \phi_i^{\mathcal{Q}}(\mathbf{y}) \neq \perp \\ \phi_i^{\mathcal{Q}}(\mathbf{y}) & \text{if } \{\phi_i^{\tilde{\mathcal{Q}}}(\mathbf{y}) : \tilde{\mathcal{Q}} \in \mathcal{A}\} = \{\phi_i^{\mathcal{Q}}(\mathbf{y}), \perp\} \text{ where } \phi_i^{\mathcal{Q}}(\mathbf{y}) \neq \perp \\ 1 & \text{otherwise.} \end{cases}$$

Error Analysis We first show that as long as the rate tuple (R_1, R_2, \dots, R_k) satisfy the rate constraints (140), the following hold simultaneously for every honest user i which sends message $m_i \in \mathcal{M}_i$, potentially adversarial set of users $\mathcal{Q} \in \mathcal{A}$ with $i \notin \mathcal{Q}$ and for channel output \mathbf{Y} : (i) $\phi_i^{\mathcal{Q}}(\mathbf{Y})$ equals m_i with probability at least $1 - \epsilon/(k|\mathcal{A}|)$ if users \mathcal{Q} are indeed adversarial and (ii) $\phi_i^{\mathcal{Q}}(\mathbf{Y})$ either equals \perp or m_i , with probability at least $1 - \epsilon/(k|\mathcal{A}|)$, if users \mathcal{Q} are not adversarial. To this end, consider $\mathcal{Q} \in \mathcal{A}$ and assume that the adversarial users (if any) are users in set \mathcal{Q} which send $\mathbf{X}_{\mathcal{Q}}$ as their potentially adversarial input to the channel. Suppose, for $i \in \mathcal{Q}^c$ and $m_i \in \mathcal{M}_i$, user- i sends $F_i(m_i)$. Let \mathbf{Y} denote the channel output.

(i) First, consider the AV-MAC $W^{\mathcal{Q}}$. Recall that $\Gamma_i^{\mathcal{Q}}(\mathbf{Y}) = L_i(m_i)$ with probability at least $1 - \epsilon/(k|\mathcal{A}|)$. Thus, with probability at least $1 - \epsilon/(k|\mathcal{A}|)$, $\phi_i^{\mathcal{Q}}(\mathbf{Y})$ equals m_i . This also holds for any $\tilde{\mathcal{Q}} \subset \mathcal{Q}$, as we can think of this as adversarial users \mathcal{Q} where users in $\mathcal{Q} \setminus \tilde{\mathcal{Q}}$ send valid codewords.

(ii) Next, consider the AV-MAC $W^{\tilde{\mathcal{Q}}}$, for $\tilde{\mathcal{Q}} \in \mathcal{A}$ where $\tilde{\mathcal{Q}} \setminus \mathcal{Q} \neq \emptyset$. We would like to compute $\mathbb{P}(\phi_i^{\tilde{\mathcal{Q}}}(\mathbf{Y}) \notin \{m_i, \perp\})$ where for $i \in \mathcal{Q}^c$, the probability is over $G_i(L_i(m_i)), \mathbf{X}_{\mathcal{Q}}$ and the channel.

$$\begin{aligned} & \mathbb{P}(\phi_i^{\tilde{\mathcal{Q}}}(\mathbf{Y}) \notin \{m_i, \perp\}) \\ &= \mathbb{P}(\Gamma_i^{\tilde{\mathcal{Q}}}(\mathbf{Y}) \in L_i(\mathcal{M}_i \setminus \{m_i\})) \\ &= \sum_{\tilde{m}_i \in \mathcal{M}_i \setminus \mathcal{S}_{m_i}} \mathbb{P}(\Gamma_i^{\tilde{\mathcal{Q}}}(\mathbf{Y}) = \tilde{m}_i, \tilde{m}_i \in L_i(\mathcal{M}_i \setminus \{m_i\})) \end{aligned}$$

¹¹In this notation $\phi_i^{\mathcal{Q}}(\mathbf{y})$, we are suppressing the dependence of the pre-decoder (and later the decoder) on the randomness of the encoders.

$$\begin{aligned}
&= \sum_{\tilde{m}_i \in \tilde{\mathcal{M}} \setminus \mathcal{S}_{m_i}} \mathbb{P} \left(\Gamma_i^{\tilde{\mathcal{Q}}}(\mathbf{Y}) = \tilde{m}_i \right) \mathbb{P} \left(\tilde{m}_i \in L_i(\mathcal{M}_i \setminus \{m_i\}) \mid \Gamma_i^{\tilde{\mathcal{Q}}}(\mathbf{Y}) = \tilde{m}_i \right) \\
&\stackrel{(a)}{=} \sum_{\tilde{m}_i \in \tilde{\mathcal{M}} \setminus \mathcal{S}_{m_i}} \mathbb{P} \left(\Gamma_i^{\tilde{\mathcal{Q}}}(\mathbf{Y}) = \tilde{m}_i \right) \mathbb{P} \left(\tilde{m}_i \in L_i(\mathcal{M}_i \setminus \{m_i\}) \right) \\
&\stackrel{(b)}{=} \sum_{\tilde{m}_i \in \tilde{\mathcal{M}} \setminus \mathcal{S}_{m_i}} \mathbb{P} \left(\Gamma_i^{\tilde{\mathcal{Q}}}(\mathbf{Y}) = \tilde{m}_i \right) \cdot \frac{1}{v} \\
&\leq 1/v \leq \epsilon/(k|\mathcal{A}|).
\end{aligned}$$

Here, (a) holds as $\Gamma_i^{\tilde{\mathcal{Q}}}(\mathbf{Y}) \perp\!\!\!\perp L_i(\mathcal{M}_i \setminus \{m_i\})$. This is because $G_i(L_i(m_i))$ which produces \mathbf{Y} is independent of $L_i(\mathcal{M}_i \setminus \{m_i\})$ and $\Gamma_i^{\tilde{\mathcal{Q}}} \perp\!\!\!\perp L_i(\mathcal{M}_i \setminus \{m_i\})$ as $\Gamma_i^{\tilde{\mathcal{Q}}}$ is a function of AV-MAC encoders $G_i, i \in \tilde{\mathcal{Q}}^c$ which are independent of L_i . The equality (b) holds because for $\tilde{m}_i \in \tilde{\mathcal{M}} \setminus \mathcal{S}_{m_i}$,

$$\begin{aligned}
&\mathbb{P}(\tilde{m}_i \in L_i(\mathcal{M}_i \setminus \{m_i\})) \\
&= \sum_{m'_i \in \mathcal{M}_i \setminus \{m_i\}} \mathbb{P}(L_i(m'_i) = \tilde{m}_i) \\
&= \sum_{m'_i \in \mathcal{M}_i \setminus \{m_i\}} \mathbf{1}_{\{\tilde{m}_i \in \mathcal{S}_{m'_i}\}} \cdot \frac{1}{v} \\
&= 1/v.
\end{aligned}$$

By taking union bound over all users and all $\mathcal{Q} \in \mathcal{A}$, with probability $1 - \epsilon$, for each non-adversarial user i , at least one of the decoders $\phi_i^{\mathcal{Q}}, \mathcal{Q} \in \mathcal{A}$ outputs the true message while the other decoder outputs either the true message or \perp .

□

E Proof of Lemma 16

Lemma 16 (Randomness reduction). Suppose $\epsilon > 0$. Given any (N_1, \dots, N_k, n) randomized code $(F_{[1:k]}^{(n)}, \phi^{(n)}(F_{[1:k]}^{(n)}))$ satisfying

$$P_e^{\text{strong}}(F_{[1:k]}^{(n)}, \phi^{(n)}(F_{[1:k]}^{(n)})) < 2^{\epsilon/2} - 1,$$

there exist n^2 (N_1, \dots, N_k, n) deterministic codes $\{(f_{[1:K],i}, \phi(f_{[1:K],i}))\}_{i=1}^{n^2}$ ¹² such that

$$\begin{aligned}
&\frac{1}{(n^2)^{|\mathcal{Q}^c|}} \sum_{j_{\mathcal{Q}^c} \in [1:n^2]^{|\mathcal{Q}^c|}} \frac{1}{(\prod_{i \in \mathcal{Q}^c} N_i)} \\
&\quad \sum_{m_{\mathcal{Q}^c} \in \mathcal{M}_{\mathcal{Q}^c}} \mathbb{P} \left\{ (\phi(\mathbf{Y}, f_{\mathcal{Q},j_{\mathcal{Q}}}, f_{\mathcal{Q}^c,j_{\mathcal{Q}^c}}) = \hat{m}_{[1:k]} : \hat{m}_{\mathcal{Q}^c} \neq m_{\mathcal{Q}^c}) \mid \mathbf{X}_{\mathcal{Q}^c} = f_{\mathcal{Q}^c,j_{\mathcal{Q}^c}}(m_{\mathcal{Q}^c}), \mathbf{X}_{\mathcal{Q}} = \mathbf{x}_{\mathcal{Q}} \right\} < \epsilon \\
&\quad \text{for every } \mathcal{Q} \in \mathcal{A}, j_{\mathcal{Q}} \in [1:n^2]^{|\mathcal{Q}|} \text{ and } \mathbf{x}_{\mathcal{Q}} \in \mathcal{X}_{\mathcal{Q}}^n.
\end{aligned}$$

Proof. The proof follows along the lines of Jahn [8, Theorem 1]. For each $i \in [1:K]$, let $\{F_{ij}\}_{j=1}^{n^2}$ be independent samples of codebook $F_i^{(n)}$ (also independent across i). This gives the set of codes $\{(F_{ij}, \phi(F_{ij})), i \in [1:K], j \in [1:n^2], \phi := \phi^{(n)}\}$.

¹²Here, we denote the decoder corresponding to the i^{th} encoder $f_{[1:K],i}$ by $\phi(f_{[1:K],i})$. Similarly, $\phi(f_{[1:K],i})$ with input \mathbf{y} is denoted by $\phi(\mathbf{y}, f_{[1:K],i})$.

For every $\mathcal{Q} \in \mathcal{A}$, $j_{\mathcal{Q}} \in [1 : n^2]^{|\mathcal{Q}|}$, $j_{\mathcal{Q}^c} \in [1 : n^2]^{|\mathcal{Q}^c|}$ and $\mathbf{x}_{\mathcal{Q}} \in \mathcal{X}_{\mathcal{Q}}^n$, define $e_{\mathcal{Q}}(F_{\mathcal{Q},j_{\mathcal{Q}}}, F_{\mathcal{Q}^c,j_{\mathcal{Q}^c}}, \mathbf{x}_{\mathcal{Q}})$ as the expected error probability fixing the encoding maps for the adversarial users, and the non-adversarial users as $F_{\mathcal{Q},j_{\mathcal{Q}}}$, and $F_{\mathcal{Q}^c,j_{\mathcal{Q}^c}}$, respectively, and the channel inputs chosen by the adversarial users as $\mathbf{x}_{\mathcal{Q}}$, *i.e.*,

$$e_{\mathcal{Q}}(F_{\mathcal{Q},j_{\mathcal{Q}}}, F_{\mathcal{Q}^c,j_{\mathcal{Q}^c}}, \mathbf{x}_{\mathcal{Q}}) := \frac{1}{\left(\prod_{i \in \mathcal{Q}^c} N_i\right)} \sum_{m_{\mathcal{Q}^c} \in \mathcal{M}_{\mathcal{Q}^c}} \mathbb{P} \left\{ (\phi(\mathbf{Y}, F_{\mathcal{Q},j_{\mathcal{Q}}}, F_{\mathcal{Q}^c,j_{\mathcal{Q}^c}}) = \hat{m}_{[1:k]} : \hat{m}_{\mathcal{Q}^c} \neq m_{\mathcal{Q}^c}) \mid \mathbf{X}_{\mathcal{Q}^c} = F_{\mathcal{Q}^c,j_{\mathcal{Q}^c}}(m_{\mathcal{Q}^c}), \mathbf{X}_{\mathcal{Q}} = \mathbf{x}_{\mathcal{Q}} \right\}.$$

We wish to show that

$$\lim_{n \rightarrow \infty} \mathbb{P} \left(\frac{1}{(n^2)^{|\mathcal{Q}^c|}} \sum_{j_{\mathcal{Q}^c} \in [1:n^2]^{|\mathcal{Q}^c|}} e_{\mathcal{Q}}(F_{\mathcal{Q},j_{\mathcal{Q}}}, F_{\mathcal{Q}^c,j_{\mathcal{Q}^c}}, \mathbf{x}_{\mathcal{Q}}) \geq \epsilon \text{ for some } \mathcal{Q} \in \mathcal{A}, j_{\mathcal{Q}} \in [1 : n^2]^{|\mathcal{Q}|} \text{ and } \mathbf{x}_{\mathcal{Q}} \in \mathcal{X}_{\mathcal{Q}}^n \right) = 0$$

Using a union bound over $\mathcal{Q} \in \mathcal{A}$, $j_{\mathcal{Q}} \in [1 : n^2]^{|\mathcal{Q}|}$, and $\mathbf{x}_{\mathcal{Q}} \in \mathcal{X}_{\mathcal{Q}}^n$, we have

$$\begin{aligned} & \mathbb{P} \left(\frac{1}{(n^2)^{|\mathcal{Q}^c|}} \sum_{j_{\mathcal{Q}^c} \in [1:n^2]^{|\mathcal{Q}^c|}} e_{\mathcal{Q}}(F_{\mathcal{Q},j_{\mathcal{Q}}}, F_{\mathcal{Q}^c,j_{\mathcal{Q}^c}}, \mathbf{x}_{\mathcal{Q}}) \geq \epsilon \text{ for some } \mathcal{Q} \in \mathcal{A}, j_{\mathcal{Q}} \in [1 : n^2]^{|\mathcal{Q}|} \text{ and } \mathbf{x}_{\mathcal{Q}} \in \mathcal{X}_{\mathcal{Q}}^n \right) \\ & \leq \sum_{\mathcal{Q} \in \mathcal{A}, j_{\mathcal{Q}} \in [1:n^2]^{|\mathcal{Q}|}, \mathbf{x}_{\mathcal{Q}} \in \mathcal{X}_{\mathcal{Q}}^n} \mathbb{P} \left(\frac{1}{(n^2)^{|\mathcal{Q}^c|}} \sum_{j_{\mathcal{Q}^c} \in [1:n^2]^{|\mathcal{Q}^c|}} e_{\mathcal{Q}}(F_{\mathcal{Q},j_{\mathcal{Q}}}, F_{\mathcal{Q}^c,j_{\mathcal{Q}^c}}, \mathbf{x}_{\mathcal{Q}}) \geq \epsilon \right) \end{aligned}$$

Note that the summands in $\sum_{j_{\mathcal{Q}^c} \in [1:n^2]^{|\mathcal{Q}^c|}} e_{\mathcal{Q}}(F_{\mathcal{Q},j_{\mathcal{Q}}}, F_{\mathcal{Q}^c,j_{\mathcal{Q}^c}}, \mathbf{x}_{\mathcal{Q}})$ are not necessarily independent. Hence, an exponential concentration inequality cannot be directly argued. However, using a similar procedure as Jahn [8, Theorem 1], we decompose this sum into parts that consist of summands that are conditionally independent given the adversary's choices.

To this end, let $\Sigma_{n^2} := \{\tau_i : i \in [0 : n^2 - 1]\}$ be a set of permutations of $\{1, 2, \dots, n^2\}$ with

$$\tau_i(j) = (i + j) \bmod n^2 \text{ for all } j \in [1 : n^2].$$

Suppose $|\mathcal{Q}| = l$ for some $l \in [1 : k]$. For ease of notation, let $Q = \{1, 2, \dots, l\}$. Then,

$$\begin{aligned} \frac{1}{(n^2)^{|\mathcal{Q}^c|}} \sum_{j_{\mathcal{Q}^c} \in [1:n^2]^{|\mathcal{Q}^c|}} e_{\mathcal{Q}}(F_{\mathcal{Q},j_{\mathcal{Q}}}, F_{\mathcal{Q}^c,j_{\mathcal{Q}^c}}, \mathbf{x}_{\mathcal{Q}}) &= \frac{1}{(n^2)^{k-l}} \sum_{(j_{l+1}, \dots, j_k) \in [1:n^2]^{k-l}} e_{\mathcal{Q}}(F_{\mathcal{Q},j_{\mathcal{Q}}}, F_{\mathcal{Q}^c,j_{\mathcal{Q}^c}}, \mathbf{x}_{\mathcal{Q}}) \\ &= \frac{1}{(n^2)^{k-l-1}} \sum_{(\sigma_{l+2}, \sigma_{l+3}, \dots, \sigma_k) \in \Sigma_{n^2}^{k-l-1}} \left(\frac{1}{n^2} \sum_{j \in [n^2]} e_{\mathcal{Q}}(F_{\mathcal{Q},j_{\mathcal{Q}}}, (F_{l+1,j}, F_{l+2,\sigma_{l+2}(j)}, \dots, F_{k,\sigma_k(j)}), \mathbf{x}_{\mathcal{Q}}) \right). \end{aligned}$$

Now,

$$\begin{aligned} & \mathbb{P} \left(\frac{1}{(n^2)^{|\mathcal{Q}^c|}} \sum_{j_{\mathcal{Q}^c} \in [1:n^2]^{|\mathcal{Q}^c|}} e_{\mathcal{Q}}(F_{\mathcal{Q},j_{\mathcal{Q}}}, F_{\mathcal{Q}^c,j_{\mathcal{Q}^c}}, \mathbf{x}_{\mathcal{Q}}) \geq \epsilon \right) \\ &= \mathbb{P} \left(\sum_{(\sigma_{l+2}, \sigma_{l+3}, \dots, \sigma_k) \in \Sigma_{n^2}^{k-l-1}} \left(\frac{1}{n^2} \sum_{j \in [n^2]} e_{\mathcal{Q}}(F_{\mathcal{Q},j_{\mathcal{Q}}}, (F_{l+1,j}, F_{l+2,\sigma_{l+2}(j)}, \dots, F_{k,\sigma_k(j)}), \mathbf{x}_{\mathcal{Q}}) \right) \geq (n^2)^{k-l-1} \epsilon \right) \\ &\leq \mathbb{P} \left(\bigcup_{(\sigma_{l+2}, \sigma_{l+3}, \dots, \sigma_k) \in \Sigma_{n^2}^{k-l-1}} \left\{ \frac{1}{n^2} \sum_{j \in [n^2]} e_{\mathcal{Q}}(F_{\mathcal{Q},j_{\mathcal{Q}}}, (F_{l+1,j}, F_{l+2,\sigma_{l+2}(j)}, \dots, F_{k,\sigma_k(j)}), \mathbf{x}_{\mathcal{Q}}) \geq \epsilon \right\} \right) \end{aligned}$$

$$\leq \sum_{(\sigma_{l+2}, \sigma_{l+3}, \dots, \sigma_k) \in \Sigma_{n^2}^{k-l-1}} \mathbb{P} \left\{ \frac{1}{n^2} \sum_{j \in [n^2]} e_{\mathcal{Q}}(F_{\mathcal{Q}, j_{\mathcal{Q}}}, (F_{l+1, j}, F_{l+2, \sigma_{l+2}(j)}, \dots, F_{k, \sigma_k(j)}), \mathbf{x}_{\mathcal{Q}}) \geq \epsilon \right\}.$$

We note that $e_{\mathcal{Q}}(F_{\mathcal{Q}, j_{\mathcal{Q}}}, (F_{l+1, j}, F_{l+2, \sigma_{l+2}(j)}, \dots, F_{k, \sigma_k(j)}), \mathbf{x}_{\mathcal{Q}})$ is identically distributed for all $(\sigma_{l+2}, \sigma_{l+3}, \dots, \sigma_k) \in \Sigma_{n^2}^{k-l-1}$. Thus,

$$\begin{aligned} & \sum_{(\sigma_{l+2}, \sigma_{l+3}, \dots, \sigma_k) \in \Sigma_{n^2}^{k-l-1}} \mathbb{P} \left\{ \frac{1}{n^2} \sum_{j \in [n^2]} e_{\mathcal{Q}}(F_{\mathcal{Q}, j_{\mathcal{Q}}}, (F_{l+1, j}, F_{l+2, \sigma_{l+2}(j)}, \dots, F_{k, \sigma_k(j)}), \mathbf{x}_{\mathcal{Q}}) \geq \epsilon \right\} \\ & \leq (n^2)^{k-l-1} \mathbb{P} \left\{ \frac{1}{n^2} \sum_{j \in [n^2]} e_{\mathcal{Q}}(F_{\mathcal{Q}, j_{\mathcal{Q}}}, (F_{l+1, j}, F_{l+2, \tau_0(j)}, \dots, F_{k, \tau_0(j)}), \mathbf{x}_{\mathcal{Q}}) \geq \epsilon \right\} \\ & = (n^2)^{k-l-1} \mathbb{P} \left\{ \frac{1}{n^2} \sum_{j \in [n^2]} e_{\mathcal{Q}}(F_{\mathcal{Q}, j_{\mathcal{Q}}}, (F_{l+1, j}, F_{l+2, j}, \dots, F_{k, j}), \mathbf{x}_{\mathcal{Q}}) \geq \epsilon \right\} \\ & = (n^2)^{k-l-1} \mathbb{P} \left\{ \sum_{j \in [n^2]} e_{\mathcal{Q}}(F_{\mathcal{Q}, j_{\mathcal{Q}}}, (F_{l+1, j}, F_{l+2, j}, \dots, F_{k, j}), \mathbf{x}_{\mathcal{Q}}) \geq n^2 \epsilon \right\} \\ & = (n^2)^{k-l-1} \mathbb{P} \left\{ \exp \left\{ \sum_{j \in [n^2]} e_{\mathcal{Q}}(F_{\mathcal{Q}, j_{\mathcal{Q}}}, (F_{l+1, j}, F_{l+2, j}, \dots, F_{k, j}), \mathbf{x}_{\mathcal{Q}}) \right\} \geq \exp \{n^2 \epsilon\} \right\} \\ & \stackrel{(a)}{\leq} (n^2)^{k-l-1} \exp \{-n^2 \epsilon\} \mathbb{E} \left[\exp \left\{ \sum_{j \in [n^2]} e_{\mathcal{Q}}(F_{\mathcal{Q}, j_{\mathcal{Q}}}, (F_{l+1, j}, F_{l+2, j}, \dots, F_{k, j}), \mathbf{x}_{\mathcal{Q}}) \right\} \right] \\ & = (n^2)^{k-l-1} \exp \{-n^2 \epsilon\} \mathbb{E} \left[\prod_{j \in [n^2]} \exp \{e_{\mathcal{Q}}(F_{\mathcal{Q}, j_{\mathcal{Q}}}, (F_{l+1, j}, F_{l+2, j}, \dots, F_{k, j}), \mathbf{x}_{\mathcal{Q}})\} \right] \\ & = (n^2)^{k-l-1} \exp \{-n^2 \epsilon\} \mathbb{E}_{F_{\mathcal{Q}, j_{\mathcal{Q}}}} \left[\mathbb{E} \left[\prod_{j \in [n^2]} \exp \{e_{\mathcal{Q}}(F_{\mathcal{Q}, j_{\mathcal{Q}}}, (F_{l+1, j}, F_{l+2, j}, \dots, F_{k, j}), \mathbf{x}_{\mathcal{Q}})\} \middle| F_{\mathcal{Q}, j_{\mathcal{Q}}} \right] \right] \\ & \stackrel{(b)}{=} (n^2)^{k-l-1} \exp \{-n^2 \epsilon\} \mathbb{E}_{F_{\mathcal{Q}, j_{\mathcal{Q}}}} \left[\prod_{j \in [n^2]} \mathbb{E} \left[\exp \{e_{\mathcal{Q}}(F_{\mathcal{Q}, j_{\mathcal{Q}}}, (F_{l+1, j}, F_{l+2, j}, \dots, F_{k, j}), \mathbf{x}_{\mathcal{Q}})\} \middle| F_{\mathcal{Q}, j_{\mathcal{Q}}} \right] \right] \\ & \stackrel{(c)}{=} (n^2)^{k-l-1} \exp \{-n^2 \epsilon\} \mathbb{E}_{F_{\mathcal{Q}, j_{\mathcal{Q}}}} \left[\left(\mathbb{E} \left[\exp \{e_{\mathcal{Q}}(F_{\mathcal{Q}, j_{\mathcal{Q}}}, (F_{l+1, 1}, F_{l+2, 1}, \dots, F_{k, 1}), \mathbf{x}_{\mathcal{Q}})\} \middle| F_{\mathcal{Q}, j_{\mathcal{Q}}} \right] \right)^{n^2} \right] \\ & \stackrel{(d)}{\leq} (n^2)^{k-l-1} \exp \{-n^2 \epsilon\} \mathbb{E}_{F_{\mathcal{Q}, j_{\mathcal{Q}}}} \left[\left(1 + \mathbb{E} \left[e_{\mathcal{Q}}(F_{\mathcal{Q}, j_{\mathcal{Q}}}, (F_{l+1, 1}, F_{l+2, 1}, \dots, F_{k, 1}), \mathbf{x}_{\mathcal{Q}}) \middle| F_{\mathcal{Q}, j_{\mathcal{Q}}} \right] \right)^{n^2} \right] \\ & \stackrel{(e)}{\leq} (n^2)^{k-l-1} \exp \{-n^2 \epsilon\} \mathbb{E}_{F_{\mathcal{Q}, j_{\mathcal{Q}}}} \left[\left(1 + P_e^{\text{strong}} \left(F_{[1:k]}^{(n)}, \phi^{(n)} \left(F_{[1:k]}^{(n)} \right) \right) \right)^{n^2} \right] \\ & = (n^2)^{k-l-1} \exp \{-n^2 \epsilon\} \left(1 + P_e^{\text{strong}} \left(F_{[1:k]}^{(n)}, \phi^{(n)} \left(F_{[1:k]}^{(n)} \right) \right) \right)^{n^2} \\ & = \exp \left\{ -n^2 \left(\epsilon - \log \left(1 + P_e^{\text{strong}} \left(F_{[1:k]}^{(n)}, \phi^{(n)} \left(F_{[1:k]}^{(n)} \right) \right) \right) - \frac{k-l-1}{n^2} \log(n^2) \right) \right\} \end{aligned}$$

where (a) follows from Markov's inequality. (b), (c) and (d) hold because for each $j \in [1 : n^2]$, conditioned on $F_{\mathcal{Q}, j_{\mathcal{Q}}}$, $e_{\mathcal{Q}}(F_{\mathcal{Q}, j_{\mathcal{Q}}}, (F_{l+1, j}, F_{l+2, j}, \dots, F_{k, j}), \mathbf{x}_{\mathcal{Q}})$ are iid random variables taking values between 0 and 1 (recall that $2^t \leq 1+t$ for $t \in [0 : 1]$). The inequality (e) follows from the definition of $P_e^{\text{strong}}(F_{[1:k]}^{(n)}, \phi^{(n)}(F_{[1:k]}^{(n)}))$ by noting that for every realization $f_{\mathcal{Q}} \in \mathcal{F}_{\mathcal{Q}}$ of $F_{\mathcal{Q}, j_{\mathcal{Q}}}$, $\mathbb{E}[e_{\mathcal{Q}}(f_{\mathcal{Q}}, (F_{l+1, 1}, F_{l+2, 1}, \dots, F_{k, 1}), \mathbf{x}_{\mathcal{Q}})] \leq P_e^{\text{strong}}(F_{[1:k]}^{(n)}, \phi^{(n)}(F_{[1:k]}^{(n)}))$. This implies that the random variable $\mathbb{E}\left[e_{\mathcal{Q}}(F_{\mathcal{Q}, j_{\mathcal{Q}}}, (F_{l+1, 1}, F_{l+2, 1}, \dots, F_{k, 1}), \mathbf{x}_{\mathcal{Q}}) \middle| F_{\mathcal{Q}, j_{\mathcal{Q}}}\right]$ is upper bounded by $P_e^{\text{strong}}(F_{[1:k]}^{(n)}, \phi^{(n)}(F_{[1:k]}^{(n)}))$. Thus,

$$\begin{aligned} & \mathbb{P}\left(\frac{1}{(n^2)^{|\mathcal{Q}^c|}} \sum_{j_{\mathcal{Q}^c} \in [1:n^2]^{|\mathcal{Q}^c|}} e_{\mathcal{Q}}(F_{\mathcal{Q}, j_{\mathcal{Q}}}, F_{\mathcal{Q}^c, j_{\mathcal{Q}^c}}, \mathbf{x}_{\mathcal{Q}}) \geq \epsilon \text{ for some } \mathcal{Q} \in \mathcal{A}, j_{\mathcal{Q}} \in [1 : n^2]^{|\mathcal{Q}|} \text{ and } \mathbf{x}_{\mathcal{Q}} \in \mathcal{X}_{\mathcal{Q}}^n\right) \\ & \stackrel{(a)}{\leq} 2^k (n^2)^k \prod_{i \in [1:k]} |\mathcal{X}_i|^n \exp\left\{-n^2 \left(\epsilon - \log\left(1 + P_e^{\text{strong}}(F_{[1:k]}^{(n)}, \phi^{(n)}(F_{[1:k]}^{(n)}))\right) - \frac{k-l-1}{n^2} \log(n^2)\right)\right\} \\ & \rightarrow 0 \text{ for large } n. \end{aligned}$$

Here, (a) follows by recalling that $P_e^{\text{strong}}(F_{[1:k]}^{(n)}, \phi^{(n)}(F_{[1:k]}^{(n)})) < 2^{\epsilon/2} - 1$ and thus, $\epsilon > 2 \log\left(1 + P_e^{\text{strong}}(F_{[1:k]}^{(n)}, \phi^{(n)}(F_{[1:k]}^{(n)}))\right)$. \square

F Proof of Lemma 10

Proof of Lemma 10. This can be shown along the lines of the proof of [27, Theorem 12.11]. Let $\{(f_{[1:K], i}, \phi(f_{[1:K], i}))\}_{i=1}^{n^2}$ ¹³ be the n^2 deterministic (N_1, \dots, N_k, n) codes given by Lemma 16 where

$$\begin{aligned} & \frac{1}{(n^2)^{|\mathcal{Q}^c|}} \sum_{j_{\mathcal{Q}^c} \in [1:n^2]^{|\mathcal{Q}^c|}} \frac{1}{(\prod_{i \in \mathcal{Q}^c} N_i)} \\ & \sum_{m_{\mathcal{Q}^c} \in \mathcal{M}_{\mathcal{Q}^c}} \mathbb{P}\left\{(\phi(\mathbf{Y}, f_{\mathcal{Q}, j_{\mathcal{Q}}}, f_{\mathcal{Q}^c, j_{\mathcal{Q}^c}}) = \hat{m}_{[1:k]} : \hat{m}_{\mathcal{Q}^c} \neq m_{\mathcal{Q}^c}) \mid \mathbf{X}_{\mathcal{Q}^c} = f_{\mathcal{Q}^c, j_{\mathcal{Q}^c}}(m_{\mathcal{Q}^c}), \mathbf{X}_{\mathcal{Q}} = \mathbf{x}_{\mathcal{Q}}\right\} < \epsilon \quad (141) \\ & \text{for every } \mathcal{Q} \in \mathcal{A}, j_{\mathcal{Q}} \in [1 : n^2]^{|\mathcal{Q}|} \text{ and } \mathbf{x}_{\mathcal{Q}} \in \mathcal{X}_{\mathcal{Q}}^n. \end{aligned}$$

Further, since $R_i > 0$ for all $i \in [1 : k]$, let $(\hat{f}_{[1:k]}, \hat{\phi})$ be an (n^2, \dots, n^2, k_n) code where $k_n/n \rightarrow 0$. Choose n large enough such that (141) holds and

$$P_{e, \mathcal{Q}}(\hat{f}_{[1:k]}, \hat{\phi}) \leq \epsilon. \quad (142)$$

For a vector sequence $\tilde{\mathbf{s}} \in \mathcal{S}^{n+k_n}$ for any alphabet \mathcal{S} , we write $\tilde{\mathbf{s}} = (\hat{\mathbf{s}}, \mathbf{s})$, where $\hat{\mathbf{s}}$ denotes the first k_n -length part of $\tilde{\mathbf{s}}$ and \mathbf{s} denotes the last n -length part of the $\tilde{\mathbf{s}}$. Let $(\tilde{f}_{[1:k]}, \tilde{\phi})$ be a new $(\tilde{N}_1, \dots, \tilde{N}_k, \tilde{n})$ code where $\tilde{n} := k_n + n$, message set for user- i , $\tilde{M}_i = [1, 2, \dots, \tilde{N}_i] := \{1, 2, \dots, n^2\} \times [1, 2, \dots, N_i]$, for $l \in [1 : n^2], m \in [1, 2, \dots, N_i]$, $\tilde{f}_i(l, m) := (\hat{f}_i(l), f_{i, l}(m))$ and for $\tilde{\mathbf{y}} = (\hat{\mathbf{y}}, \mathbf{y})$, $\tilde{\phi}(\tilde{\mathbf{y}}) := (\hat{l}_{[1:k]}, \phi(\mathbf{y}, f_{[1:k], \hat{l}_{[1:k]}}))$ where $\hat{l}_{[1:k]} = \hat{\phi}(\hat{\mathbf{y}})$. Then, for $\mathcal{Q} \in \mathcal{A}$,

$$P_{e, \mathcal{Q}}(\tilde{f}_{[1:k]}, \tilde{\phi}) = \max_{\substack{(\hat{\mathbf{x}}_{\mathcal{Q}}, \mathbf{x}_{\mathcal{Q}}) \\ \in \mathcal{X}_{\mathcal{Q}}^{k_n} \times \mathcal{X}_{\mathcal{Q}}^n}} \frac{1}{(\prod_{i \in \mathcal{Q}^c} \tilde{N}_i)} \sum_{\tilde{m}_{\mathcal{Q}^c} \in \tilde{\mathcal{M}}_{\mathcal{Q}^c}} \mathbb{P}\left(\left\{\tilde{\phi}(\tilde{\mathbf{Y}}) = m'_{[1:k]} : m'_{\mathcal{Q}^c} \neq \tilde{m}_{\mathcal{Q}^c}\right\} \middle| \tilde{\mathbf{X}}_{\mathcal{Q}^c} = \tilde{f}_{\mathcal{Q}^c}(\tilde{m}_{\mathcal{Q}^c}), \tilde{\mathbf{X}}_{\mathcal{Q}} = (\hat{\mathbf{x}}_{\mathcal{Q}}, \mathbf{x}_{\mathcal{Q}})\right)$$

¹³Here, we denote the decoder corresponding to the i^{th} encoder $f_{[1:K], i}$ by $\phi(f_{[1:K], i})$. Similarly, $\phi(f_{[1:K], i})$ with input \mathbf{y} is denoted by $\phi(\mathbf{y}, f_{[1:K], i})$.

$$\begin{aligned}
&\leq \max_{\hat{\mathbf{x}}_{\mathcal{Q}}, \hat{l}_{\mathcal{Q}}} \frac{1}{(n^2)^{|\mathcal{Q}^c|} (\prod_{i \in \mathcal{Q}^c} N_i)} \sum_{l_{\mathcal{Q}^c} \in [1:n^2]^{|\mathcal{Q}^c|}} \sum_{m_{\mathcal{Q}^c} \in \mathcal{M}_{\mathcal{Q}^c}} \mathbb{P} \left(\left\{ \hat{\phi}(\hat{\mathbf{Y}}) = \bar{l}_{[1:k]} : \bar{l}_{\mathcal{Q}^c} \neq l_{\mathcal{Q}^c} \right\} \cup \right. \\
&\quad \left. \left\{ \phi(\mathbf{Y}, f_{\mathcal{Q}}, l_{\mathcal{Q}}, f_{\mathcal{Q}^c}, l_{\mathcal{Q}^c}) = \bar{m}_{[1:k]} : \bar{m}_{\mathcal{Q}^c} \neq m_{\mathcal{Q}^c} \right\} \mid (\hat{\mathbf{X}}_{\mathcal{Q}^c}, \mathbf{X}_{\mathcal{Q}^c}) = (f_{\mathcal{Q}^c}(l_{\mathcal{Q}^c}), f_{\mathcal{Q}^c, l_{\mathcal{Q}^c}}(m_{\mathcal{Q}^c})), (\hat{\mathbf{X}}_{\mathcal{Q}} = \hat{\mathbf{x}}_{\mathcal{Q}}, \mathbf{X}_{\mathcal{Q}} = \mathbf{x}_{\mathcal{Q}}) \right) \\
&\leq \max_{\hat{\mathbf{x}}_{\mathcal{Q}}} \frac{1}{(n^2)^{|\mathcal{Q}^c|}} \sum_{l_{\mathcal{Q}^c} \in [1:n^2]^{|\mathcal{Q}^c|}} \mathbb{P} \left(\left\{ \hat{\phi}(\hat{\mathbf{Y}}) = \bar{l}_{[1:k]} : \bar{l}_{\mathcal{Q}^c} \neq l_{\mathcal{Q}^c} \right\} \mid \hat{\mathbf{X}}_{\mathcal{Q}^c} = \hat{f}_{\mathcal{Q}^c}(l_{\mathcal{Q}^c}), \hat{\mathbf{X}}_{\mathcal{Q}} = \hat{\mathbf{x}}_{\mathcal{Q}} \right) \\
&+ \max_{\mathbf{x}_{\mathcal{Q}}} \frac{1}{(n^2)^{|\mathcal{Q}^c|} (\prod_{i \in \mathcal{Q}^c} N_i)} \sum_{l_{\mathcal{Q}^c} \in [1:n^2]^{|\mathcal{Q}^c|}} \sum_{m_{\mathcal{Q}^c} \in \mathcal{M}_{\mathcal{Q}^c}} \mathbb{P} \left(\left\{ \phi(\mathbf{Y}, f_{\mathcal{Q}}, l_{\mathcal{Q}}, f_{\mathcal{Q}^c}, l_{\mathcal{Q}^c}) = \bar{m}_{[1:k]} : \bar{m}_{\mathcal{Q}^c} \neq m_{\mathcal{Q}^c} \right\} \mid \right. \\
&\quad \left. \mathbf{X}_{\mathcal{Q}^c} = f_{\mathcal{Q}^c, l_{\mathcal{Q}^c}}(m_{\mathcal{Q}^c}), \mathbf{X}_{\mathcal{Q}} = \mathbf{x}_{\mathcal{Q}} \right) \\
&\stackrel{(a)}{\leq} 2\epsilon.
\end{aligned}$$

where (a) follows from (141) and (142). \square

G Proof of Lemma 9

Proof of Lemma 9. The codebook is given by Lemma 17 below. Its proof is along the lines of [10, Lemma 2] and [22, Lemma 3] and is given after the current proof.

Lemma 17. For any $\epsilon > 0$, large enough n , $N \geq \exp(n\epsilon)$ and types $P_i \in \mathcal{P}_{\mathcal{X}_i}^n : i \in [1:k]$, there exist codebooks \mathcal{C}_i , $i \in [1:k]$ for message sets $\mathcal{M}_i = [1:N]$, $i \in [1:k]$, whose codewords are of type P_i , $i \in [1:k]$ respectively such that for every $\mathcal{Q} \in \mathcal{A}$ such that $|\mathcal{Q}| < k^{14}$, $\mathbf{x}_{\mathcal{Q}} \in \mathcal{X}_{\mathcal{Q}}^n$, $\mathcal{T} \subseteq \mathcal{Q}^c$, $\mathcal{J} \subseteq \mathcal{Q}$, and joint type $P_{X_{\mathcal{Q}^c} X_{\mathcal{Q}} X'_{\mathcal{T}} X'_{\mathcal{J}}} \in \mathcal{P}_{\mathcal{X}_{\mathcal{Q}^c} \times \mathcal{X}_{\mathcal{Q}} \times \mathcal{X}'_{\mathcal{T}} \times \mathcal{X}'_{\mathcal{J}}}^n$, the following holds:

(a) If for any $i \in \mathcal{Q}^c$, $I(X_i; X_{\mathcal{Q}^c \setminus \{i\}} X_{\mathcal{Q}}) \geq \epsilon$, then,

$$\frac{1}{N^{|\mathcal{Q}^c|}} |\{m_{\mathcal{Q}^c} \in \mathcal{M}_{\mathcal{Q}^c} : (f_{\mathcal{Q}^c}(m_{\mathcal{Q}^c}), \mathbf{x}_{\mathcal{Q}}) \in T_{X_{\mathcal{Q}^c} X_{\mathcal{Q}}}^n\}| < \exp\{-n\epsilon/2\}.$$

(b) If for any $i \in \mathcal{Q}^c$, $I(X_i; X_{\mathcal{Q}^c \setminus \{i\}} X'_{\mathcal{T}} X'_{\mathcal{J}} X_{\mathcal{Q}}) \geq (|\mathcal{T}| + |\mathcal{J}|)(1/n) \log_2 N + \epsilon$, then,

$$\frac{1}{N^{|\mathcal{Q}^c|}} |\{m_{\mathcal{Q}^c} \in \mathcal{M}_{\mathcal{Q}^c} : \exists m'_{\mathcal{J}} \in \mathcal{M}_{\mathcal{J}}, m'_{\mathcal{T}} \in \mathcal{M}_{\mathcal{T}}, m'_i \neq m_i, \forall i \in \mathcal{T}, (f_{\mathcal{Q}^c}(m_{\mathcal{Q}^c}), f_{\mathcal{T}}(m'_{\mathcal{T}}), f_{\mathcal{J}}(m'_{\mathcal{J}}), \mathbf{x}_{\mathcal{Q}}) \in T_{X_{\mathcal{Q}^c} X'_{\mathcal{T}} X'_{\mathcal{J}} X_{\mathcal{Q}}}^n\}| < \exp\{-n\epsilon/2\}.$$

For $\epsilon > 0$ (TBD), large enough n , $N \geq \exp(n\epsilon)$ and types $P_i \in \mathcal{P}_{\mathcal{X}_i}^n$, $i \in [1:k]$, such that $\min_{i \in [1:k]} \min_{x_i \in \mathcal{X}_i} P_i > 0$, consider the codebooks \mathcal{C}_i , $i \in [1:k]$ for message sets $\mathcal{M}_i = [1:N]$, $i \in [1:k]$ as given by Lemma 17. The rates of the codebooks $R_i = R = \log_2(N)/n$ for some $R \geq \epsilon$. The decoder is given by Definition 10 for η satisfying Lemma 19. We will choose ϵ such that $\eta > (2k+1)(k+1)\epsilon$.

Let $\mathcal{Q} \in \mathcal{A}$ be the set of adversarial users who attack with input vector $\mathbf{x}_{\mathcal{Q}} \in \mathcal{X}_{\mathcal{Q}}^n$. The probability of error is given by

$$\frac{1}{N^{|\mathcal{Q}^c|}} \sum_{m_{\mathcal{Q}^c}} \mathbb{P}(\{\mathbf{y} : \phi(\mathbf{y}) \neq (m_{\mathcal{Q}^c}, m_{\mathcal{Q}}) \text{ for some } m_{\mathcal{Q}}\} \mid \mathbf{X}_{\mathcal{Q}^c} = f_{\mathcal{Q}^c}(m_{\mathcal{Q}^c}), \mathbf{X}_{\mathcal{Q}} = \mathbf{x}_{\mathcal{Q}}) \quad (143)$$

¹⁴Note that there are no decoding guarantees when all users are malicious, so we only consider the case when at least one user is honest.

From the decoder definition (Definition 10), we know that if $\phi(\mathbf{y}) = \tilde{m}_{[1:k]}$ where $m_{\mathcal{Q}^c} \neq \tilde{m}_{\mathcal{Q}^c}$, then $\mathbf{y} \notin \cap_{i \in \mathcal{Q}^c} \mathcal{D}_{m_i}^{(i)}$, that is, $\mathbf{y} \in \cup_{i \in \mathcal{Q}^c} (\mathcal{D}_{m_i}^{(i)})^c$. Thus, (143) can be written as

$$\begin{aligned} & \frac{1}{N^{|\mathcal{Q}^c|}} \sum_{m_{\mathcal{Q}^c}} \mathbb{P} \left(\left\{ \mathbf{y} : \mathbf{y} \notin \cap_{i \in \mathcal{Q}^c} \mathcal{D}_{m_i}^{(i)} \right\} \middle| \mathbf{X}_{\mathcal{Q}^c} = f_{\mathcal{Q}^c}(m_{\mathcal{Q}^c}), \mathbf{X}_{\mathcal{Q}} = \mathbf{x}_{\mathcal{Q}} \right) \\ & \leq \sum_{i \in \mathcal{Q}^c} \frac{1}{N^{|\mathcal{Q}^c|}} \sum_{m_{\mathcal{Q}^c}} \mathbb{P} \left(\left\{ \mathbf{y} : \mathbf{y} \notin \mathcal{D}_{m_i}^{(i)} \right\} \middle| \mathbf{X}_{\mathcal{Q}^c} = f_{\mathcal{Q}^c}(m_{\mathcal{Q}^c}), \mathbf{X}_{\mathcal{Q}} = \mathbf{x}_{\mathcal{Q}} \right) \end{aligned} \quad (144)$$

We will show that each term in (144) falls exponentially. It holds when for joint distribution $P_{X_{\mathcal{Q}^c} X_{\mathcal{Q}}}$ defined by $(f_{\mathcal{Q}^c}(m_{\mathcal{Q}^c}), \mathbf{x}_{\mathcal{Q}}) \in T_{X_{\mathcal{Q}^c} X_{\mathcal{Q}}}^n$, $I(X_i; X_{\mathcal{Q}^c \setminus \{i\}} X_{\mathcal{Q}}) \geq \epsilon$ for any $i \in \mathcal{Q}^c$. This is because for any $j \in \mathcal{Q}^c$,

$$\begin{aligned} & \frac{1}{N^{|\mathcal{Q}^c|}} \sum_{\substack{m_{\mathcal{Q}^c}: (f_{\mathcal{Q}^c}(m_{\mathcal{Q}^c}), \mathbf{x}_{\mathcal{Q}}) \in T_{X_{\mathcal{Q}^c} X_{\mathcal{Q}}}^n, \\ I(X_i; X_{\mathcal{Q}^c \setminus \{i\}} X_{\mathcal{Q}}) \geq \epsilon \text{ for some } i \in \mathcal{Q}^c}} \mathbb{P} \left(\left\{ \mathbf{y} : \mathbf{y} \notin \mathcal{D}_{m_j}^{(j)} \right\} \middle| \mathbf{X}_{\mathcal{Q}^c} = f_{\mathcal{Q}^c}(m_{\mathcal{Q}^c}), \mathbf{X}_{\mathcal{Q}} = \mathbf{x}_{\mathcal{Q}} \right) \\ & \leq \sum_{\substack{P_{X_{\mathcal{Q}^c} X_{\mathcal{Q}}}: \\ I(X_i; X_{\mathcal{Q}^c \setminus \{i\}} X_{\mathcal{Q}}) \geq \epsilon \text{ for some } i \in \mathcal{Q}^c}} \frac{1}{N^{|\mathcal{Q}^c|}} |\{m_{\mathcal{Q}^c} \in \mathcal{M}_{\mathcal{Q}^c} : (f_{\mathcal{Q}^c}(m_{\mathcal{Q}^c}), \mathbf{x}_{\mathcal{Q}}) \in T_{X_{\mathcal{Q}^c} X_{\mathcal{Q}}}^n\}| \\ & \stackrel{(a)}{<} \sum_{P_{X_{\mathcal{Q}^c} X_{\mathcal{Q}}}} \exp \{-n\epsilon/2\} \\ & \rightarrow 0 \end{aligned}$$

where (a) follows from Lemma 17(a). Thus, we can assume that $I(X_i; X_{\mathcal{Q}^c \setminus \{i\}} X_{\mathcal{Q}}) < \epsilon$ for all $i \in \mathcal{Q}^c$. This implies that

$$\begin{aligned} |\mathcal{Q}^c| \epsilon & > \sum_{i \in \mathcal{Q}^c} I(X_i; X_{\mathcal{Q}^c \setminus \{i\}} X_{\mathcal{Q}}) \\ & \geq D \left(P_{X_{\mathcal{Q}^c} X_{\mathcal{Q}}} \middle| \middle| \left(\prod_{i \in \mathcal{Q}^c} P_{X_i} \right) P_{X_{\mathcal{Q}}} \right). \end{aligned}$$

Under this case, for any $j \in \mathcal{Q}^c$,

$$\begin{aligned} & \frac{1}{N^{|\mathcal{Q}^c|}} \sum_{\substack{m_{\mathcal{Q}^c}: (f_{\mathcal{Q}^c}(m_{\mathcal{Q}^c}), \mathbf{x}_{\mathcal{Q}}) \in T_{X_{\mathcal{Q}^c} X_{\mathcal{Q}}}^n, \\ I(X_i; X_{\mathcal{Q}^c \setminus \{i\}} X_{\mathcal{Q}}) < \epsilon \forall i \in \mathcal{Q}^c}} \mathbb{P} \left(\left\{ \mathbf{y} : \mathbf{y} \notin \mathcal{D}_{m_j}^{(j)} \right\} \middle| \mathbf{X}_{\mathcal{Q}^c} = f_{\mathcal{Q}^c}(m_{\mathcal{Q}^c}), \mathbf{X}_{\mathcal{Q}} = \mathbf{x}_{\mathcal{Q}} \right) \quad (145) \\ & \leq \sum_{\substack{P_{X_{\mathcal{Q}^c} X_{\mathcal{Q}}}: \\ I(X_i; X_{\mathcal{Q}^c \setminus \{i\}} X_{\mathcal{Q}}) < \epsilon \forall i \in \mathcal{Q}^c}} \frac{1}{N^{|\mathcal{Q}^c|}} \sum_{\substack{m_{\mathcal{Q}^c}: \\ (f_{\mathcal{Q}^c}(m_{\mathcal{Q}^c}), \mathbf{x}_{\mathcal{Q}}) \in T_{X_{\mathcal{Q}^c} X_{\mathcal{Q}}}^n}} \sum_{y \in T_{Y|X_{\mathcal{Q}^c} X_{\mathcal{Q}}}^n(f_{\mathcal{Q}^c}(m_{\mathcal{Q}^c}), \mathbf{x}_{\mathcal{Q}})} W^n(y | f_{\mathcal{Q}^c}(m_{\mathcal{Q}^c}), \mathbf{x}_{\mathcal{Q}}) \\ & \leq \sum_{\substack{P_{X_{\mathcal{Q}^c} X_{\mathcal{Q}}}: \\ I(X_i; X_{\mathcal{Q}^c \setminus \{i\}} X_{\mathcal{Q}}) < \epsilon \forall i \in \mathcal{Q}^c}} \frac{1}{N^{|\mathcal{Q}^c|}} \sum_{m_{\mathcal{Q}^c}: (f_{\mathcal{Q}^c}(m_{\mathcal{Q}^c}), \mathbf{x}_{\mathcal{Q}}) \in T_{X_{\mathcal{Q}^c} X_{\mathcal{Q}}}^n} \exp \left\{ -nD \left(P_{X_{\mathcal{Q}^c} X_{\mathcal{Q}} Y} \middle| \middle| P_{X_{\mathcal{Q}^c} X_{\mathcal{Q}}} W \right) \right\} \\ & \leq \sum_{\substack{P_{X_{\mathcal{Q}^c} X_{\mathcal{Q}}}: \\ I(X_i; X_{\mathcal{Q}^c \setminus \{i\}} X_{\mathcal{Q}}) < \epsilon \forall i \in \mathcal{Q}^c}} \exp \left\{ -nD \left(P_{X_{\mathcal{Q}^c} X_{\mathcal{Q}} Y} \middle| \middle| P_{X_{\mathcal{Q}^c} X_{\mathcal{Q}}} W \right) \right\} \\ & \leq \sum_{\substack{P_{X_{\mathcal{Q}^c} X_{\mathcal{Q}}}: \\ I(X_i; X_{\mathcal{Q}^c \setminus \{i\}} X_{\mathcal{Q}}) < \epsilon \forall i \in \mathcal{Q}^c}} \exp \left\{ -n \left(D \left(P_{X_{\mathcal{Q}^c} X_{\mathcal{Q}} Y} \middle| \middle| \left(\prod_{i \in \mathcal{Q}^c} P_{X_i} \right) P_{X_{\mathcal{Q}}} W \right) - D \left(P_{X_{\mathcal{Q}^c} X_{\mathcal{Q}}} \middle| \middle| \left(\prod_{i \in \mathcal{Q}^c} P_{X_i} \right) P_{X_{\mathcal{Q}}} \right) \right) \right\} \end{aligned} \quad (146)$$

We will break (146) into two terms, first corresponding to joint distributions $P_{X_{\mathcal{Q}^c}X_{\mathcal{Q}}Y}$ for which $D\left(P_{X_{\mathcal{Q}^c}X_{\mathcal{Q}}Y}\left\|\left(\prod_{i\in\mathcal{Q}^c}P_{X_i}\right)P_{X_{\mathcal{Q}}}W\right.\right)\geq\eta$ and second corresponding to joint distributions for which $D\left(P_{X_{\mathcal{Q}^c}X_{\mathcal{Q}}Y}\left\|\left(\prod_{i\in\mathcal{Q}^c}P_{X_i}\right)P_{X_{\mathcal{Q}}}W\right.\right)<\eta$. Let us start by considering $P_{X_{\mathcal{Q}^c}X_{\mathcal{Q}}Y}$ such that $D\left(P_{X_{\mathcal{Q}^c}X_{\mathcal{Q}}Y}\left\|\left(\prod_{i\in\mathcal{Q}^c}P_{X_i}\right)P_{X_{\mathcal{Q}}}W\right.\right)\geq\eta$.

$$\begin{aligned} & \sum_{\substack{P_{X_{\mathcal{Q}^c}X_{\mathcal{Q}}}: \\ I(X_i;X_{\mathcal{Q}^c\setminus\{i\}}X_{\mathcal{Q}})<\epsilon,\forall i\in\mathcal{Q}^c,}} \exp\left\{-n\left(D\left(P_{X_{\mathcal{Q}^c}X_{\mathcal{Q}}Y}\left\|\left(\prod_{i\in\mathcal{Q}^c}P_{X_i}\right)P_{X_{\mathcal{Q}}}W\right.\right)-D\left(P_{X_{\mathcal{Q}^c}X_{\mathcal{Q}}}\left\|\left(\prod_{i\in\mathcal{Q}^c}P_{X_i}\right)P_{X_{\mathcal{Q}}}\right.\right)\right)\right\} \\ & D\left(P_{X_{\mathcal{Q}^c}X_{\mathcal{Q}}Y}\left\|\left(\prod_{i\in\mathcal{Q}^c}P_{X_i}\right)P_{X_{\mathcal{Q}}}W\right.\right)\geq\eta \\ & \leq \sum_{\substack{P_{X_{\mathcal{Q}^c}X_{\mathcal{Q}}}: \\ I(X_i;X_{\mathcal{Q}^c\setminus\{i\}}X_{\mathcal{Q}})<\epsilon,\forall i\in\mathcal{Q}^c}} \exp\{-n(\eta-|\mathcal{Q}^c|\epsilon)\} \\ & \rightarrow 0 \text{ for } \eta > k\epsilon. \end{aligned}$$

Now, we need to evaluate (146) for joint distributions $P_{X_{\mathcal{Q}^c}X_{\mathcal{Q}}Y}$ for which $D\left(P_{X_{\mathcal{Q}^c}X_{\mathcal{Q}}Y}\left\|\left(\prod_{i\in\mathcal{Q}^c}P_{X_i}\right)P_{X_{\mathcal{Q}}}W\right.\right)<\eta$. In this case, since decoding condition 1 holds, $\mathbf{y} \notin \mathcal{D}_{m_j}^{(j)}$ if decoding condition 2 fails. That is, there exist $\mathcal{Q}' \in \mathcal{A}$, not necessarily distinct from \mathcal{Q} , a non-empty set $\mathcal{T} \subseteq (\mathcal{Q} \cup \mathcal{Q}')^c$ with $j \in \mathcal{T}$, $\mathbf{x}'_{\mathcal{Q}'} \in \mathcal{X}_{\mathcal{Q}'}$, $m'_{\mathcal{Q}\setminus\mathcal{Q}'} \in \mathcal{M}_{\mathcal{Q}\setminus\mathcal{Q}'}$, $m'_{\mathcal{T}} \in \mathcal{M}_{\mathcal{T}}$ such that $m'_i \neq m_i$ for all $i \in \mathcal{T}$ such that for the joint distribution $P_{X_{\mathcal{Q}^c}X_{\mathcal{Q}}X'_{\mathcal{T}}X'_{\mathcal{Q}\setminus\mathcal{Q}'}X'_{\mathcal{Q}'},Y}$ defined by $(f_{\mathcal{Q}^c}(m_{\mathcal{Q}^c}), \mathbf{x}_{\mathcal{Q}}, f_{\mathcal{T}}(m'_{\mathcal{T}}), f_{\mathcal{Q}\setminus\mathcal{Q}'}(m'_{\mathcal{Q}\setminus\mathcal{Q}'}), \mathbf{x}'_{\mathcal{Q}'}, \mathbf{y}) \in T_{X_{\mathcal{Q}^c}X_{\mathcal{Q}}X'_{\mathcal{T}}X'_{\mathcal{Q}\setminus\mathcal{Q}'}X'_{\mathcal{Q}'},Y}^n$,

$$\begin{aligned} & D(P_{X'_{\mathcal{T}}X'_{\mathcal{Q}\setminus\mathcal{Q}'}X_{\mathcal{Q}^c\setminus(\mathcal{T}\cup\mathcal{Q}')},Y}\left\|\left(\prod_{t\in\mathcal{T}}P_{X_t}\right)\left(\prod_{j\in\mathcal{Q}\setminus\mathcal{Q}'}P_{X_j}\right)\left(\prod_{l\in\mathcal{Q}^c\setminus(\mathcal{T}\cup\mathcal{Q}')}P_{X_l}\right)P_{X'_{\mathcal{Q}'}}W\right.) < \eta \\ & \text{and } I(X_{\mathcal{Q}^c}Y; X'_{\mathcal{T}}X'_{\mathcal{Q}\setminus\mathcal{Q}'}|X_{\mathcal{Q}}) \geq \eta. \end{aligned}$$

Let $\mathcal{H} := \mathcal{Q}^c \setminus (\mathcal{T} \cup \mathcal{Q}')$ and $\mathcal{P}_{X_{\mathcal{Q}^c}X_{\mathcal{Q}}X'_{\mathcal{T}}X'_{\mathcal{Q}\setminus\mathcal{Q}'}X'_{\mathcal{Q}'},Y}^1$ be the set of distributions $P_{X_{\mathcal{Q}^c}X_{\mathcal{Q}}X'_{\mathcal{T}}X'_{\mathcal{Q}\setminus\mathcal{Q}'}X'_{\mathcal{Q}'},Y}$ satisfying $D\left(P_{X_{\mathcal{Q}^c}X_{\mathcal{Q}}Y}\left\|\left(\prod_{i\in\mathcal{Q}^c}P_{X_i}\right)P_{X_{\mathcal{Q}}}W\right.\right)\leq\eta$, $D(P_{X'_{\mathcal{T}}X'_{\mathcal{Q}\setminus\mathcal{Q}'}X_{\mathcal{H}}X'_{\mathcal{Q}'},Y}\left\|\left(\prod_{t\in\mathcal{T}}P_{X_t}\right)\left(\prod_{j\in\mathcal{Q}\setminus\mathcal{Q}'}P_{X_j}\right)\left(\prod_{l\in\mathcal{H}}P_{X_l}\right)P_{X'_{\mathcal{Q}'}}W\right.)<\eta$ and $I(X_{\mathcal{Q}^c}Y; X'_{\mathcal{T}}X'_{\mathcal{Q}\setminus\mathcal{Q}'}|X_{\mathcal{Q}}) \geq \eta$. Using these definitions we see that, in this case, (145) is upper bounded by

$$\begin{aligned} & \sum_{\substack{P_{X_{\mathcal{Q}^c}X_{\mathcal{Q}}X'_{\mathcal{T}}X'_{\mathcal{Q}\setminus\mathcal{Q}'}X'_{\mathcal{Q}'},Y} \\ \in \mathcal{P}_{X_{\mathcal{Q}^c}X_{\mathcal{Q}}X'_{\mathcal{T}}X'_{\mathcal{Q}\setminus\mathcal{Q}'}X'_{\mathcal{Q}'},Y}^1}} \frac{1}{N^{|\mathcal{Q}^c|}} \left| \left\{ m_{\mathcal{Q}^c} \in \mathcal{M}_{\mathcal{Q}^c} : \exists m'_{\mathcal{Q}\setminus\mathcal{Q}'} \in \mathcal{M}_{\mathcal{Q}\setminus\mathcal{Q}'}, m'_{\mathcal{T}} \in \mathcal{M}_{\mathcal{T}} \text{ where } m'_i \neq m_i \text{ for all } i \in \mathcal{T}, \right. \right. \\ & \left. \left. \text{such that } (f_{\mathcal{Q}^c}(m_{\mathcal{Q}^c}), f_{\mathcal{T}}(m'_{\mathcal{T}}), f_{\mathcal{Q}\setminus\mathcal{Q}'}(m'_{\mathcal{Q}\setminus\mathcal{Q}'}), \mathbf{x}_{\mathcal{Q}}) \in T_{X_{\mathcal{Q}^c}X_{\mathcal{Q}}X'_{\mathcal{T}}X'_{\mathcal{Q}\setminus\mathcal{Q}'}X'_{\mathcal{Q}'},Y}^n \right\} \right| \\ & \leq \sum_{\substack{P_{X_{\mathcal{Q}^c}X_{\mathcal{Q}}X'_{\mathcal{T}}X'_{\mathcal{Q}\setminus\mathcal{Q}'}X'_{\mathcal{Q}'},Y} \\ \in \mathcal{P}_{X_{\mathcal{Q}^c}X_{\mathcal{Q}}X'_{\mathcal{T}}X'_{\mathcal{Q}\setminus\mathcal{Q}'}X'_{\mathcal{Q}'},Y}^1}} \exp\{-n\epsilon/2\} \rightarrow 0 \end{aligned}$$

if for any $i \in \mathcal{Q}^c$, $I(X_i; X_{\mathcal{Q}^c\setminus\{i\}}X'_{\mathcal{T}}X'_{\mathcal{Q}\setminus\mathcal{Q}'}, X_{\mathcal{Q}}) \geq (|\mathcal{T}| + |(\mathcal{Q} \setminus \mathcal{Q}')|)R + \epsilon$. This follows from the codebook property Lemma 17(b). Thus, we only need to consider joint distributions for which $I(X_i; X_{\mathcal{Q}^c\setminus\{i\}}X'_{\mathcal{T}}X'_{\mathcal{Q}\setminus\mathcal{Q}'}, X_{\mathcal{Q}}) < (|\mathcal{T}| + |(\mathcal{Q} \setminus \mathcal{Q}')|)R + \epsilon$ for all $i \in \mathcal{Q}^c$. This implies that $I(X_{\mathcal{Q}^c}; X'_{\mathcal{Q}\setminus\mathcal{Q}'}X'_{\mathcal{T}}|X_{\mathcal{Q}}) \leq |\mathcal{Q}^c|((|\mathcal{T}| + |(\mathcal{Q} \setminus \mathcal{Q}')|)R + \epsilon)$. This is because $I(X_{\mathcal{Q}^c}; X'_{\mathcal{Q}\setminus\mathcal{Q}'}X'_{\mathcal{T}}|X_{\mathcal{Q}}) \leq \sum_{i\in\mathcal{Q}^c} I(X_i; X'_{\mathcal{Q}\setminus\mathcal{Q}'}X'_{\mathcal{T}}X_{\mathcal{Q}^c\setminus\{i\}}|X_{\mathcal{Q}})$.

Let $\mathcal{P}_{X_{\mathcal{Q}^c}X_{\mathcal{Q}}X'_{\mathcal{T}}X'_{\mathcal{Q}'\setminus\mathcal{Q}},X'_{\mathcal{Q}'},Y}^2 = \{P_{X_{\mathcal{Q}^c}X_{\mathcal{Q}}X'_{\mathcal{T}}X'_{\mathcal{Q}'\setminus\mathcal{Q}},X'_{\mathcal{Q}'},Y} \in \mathcal{P}_{X_{\mathcal{Q}^c}X_{\mathcal{Q}}X'_{\mathcal{T}}X'_{\mathcal{Q}'\setminus\mathcal{Q}},X'_{\mathcal{Q}'},Y}^1 : I(X_{\mathcal{Q}^c}; X'_{\mathcal{Q}'\setminus\mathcal{Q}}, X'_{\mathcal{T}}|X_{\mathcal{Q}}) \leq |\mathcal{Q}^c|((|\mathcal{T}| + |(\mathcal{Q} \setminus \mathcal{Q}')|)R + \epsilon)\}$. So, for any $j \in \mathcal{Q}^c$, it is sufficient to analyze the following:

$$\begin{aligned}
& \sum_{\mathcal{Q}' \in \mathcal{A}} \sum_{\substack{P_{X_{\mathcal{Q}^c}X_{\mathcal{Q}}X'_{\mathcal{T}}X'_{\mathcal{Q}'\setminus\mathcal{Q}},X'_{\mathcal{Q}'},Y} \\ \mathcal{P}_{X_{\mathcal{Q}^c}X_{\mathcal{Q}}X'_{\mathcal{T}}X'_{\mathcal{Q}'\setminus\mathcal{Q}},X'_{\mathcal{Q}'},Y}^2}} \frac{1}{N^{|\mathcal{Q}^c|}} \sum_{\substack{m_{\mathcal{Q}^c}: \\ (f_{\mathcal{Q}^c}(m_{\mathcal{Q}^c}), \mathbf{x}_{\mathcal{Q}}) \in T_{X_{\mathcal{Q}^c}X_{\mathcal{Q}}}^n}} \sum_{\substack{\mathbf{y} \in T_{Y|X_{\mathcal{Q}^c}X_{\mathcal{Q}}}^n \\ \mathbf{y} \notin \mathcal{D}_{m_j}^{(j)}}} W^n(\mathbf{y}|f_{\mathcal{Q}^c}(m_{\mathcal{Q}^c}), \mathbf{x}_{\mathcal{Q}}) \\
& \leq \sum_{\mathcal{Q}' \in \mathcal{A}} \sum_{\substack{P_{X_{\mathcal{Q}^c}X_{\mathcal{Q}}X'_{\mathcal{T}}X'_{\mathcal{Q}'\setminus\mathcal{Q}},X'_{\mathcal{Q}'},Y} \\ \mathcal{P}_{X_{\mathcal{Q}^c}X_{\mathcal{Q}}X'_{\mathcal{T}}X'_{\mathcal{Q}'\setminus\mathcal{Q}},X'_{\mathcal{Q}'},Y}^2}} \frac{1}{N^{|\mathcal{Q}^c|}} \sum_{\substack{m_{\mathcal{Q}^c}: \\ (f_{\mathcal{Q}^c}(m_{\mathcal{Q}^c}), \mathbf{x}_{\mathcal{Q}}) \in T_{X_{\mathcal{Q}^c}X_{\mathcal{Q}}}^n}} \sum_{\substack{m'_{\mathcal{Q}'\setminus\mathcal{Q}} \in \mathcal{M}_{\mathcal{Q}'\setminus\mathcal{Q}}, \\ m'_{\mathcal{T}} \in \mathcal{M}_{\mathcal{T}} \\ (f_{\mathcal{Q}'\setminus\mathcal{Q}}(m'_{\mathcal{Q}'\setminus\mathcal{Q}}), f_{\mathcal{T}}(m'_{\mathcal{T}})) \in T_{X'_{\mathcal{Q}'\setminus\mathcal{Q}}, X'_{\mathcal{T}}|X_{\mathcal{Q}^c}X_{\mathcal{Q}}}^n}} W^n(\mathbf{y}|f_{\mathcal{Q}^c}(m_{\mathcal{Q}^c}), \mathbf{x}_{\mathcal{Q}}) \\
& \quad \sum_{\mathbf{y} \in T_{Y|X_{\mathcal{Q}^c}X_{\mathcal{Q}}X'_{\mathcal{Q}'\setminus\mathcal{Q}}, X'_{\mathcal{T}}}^n} W^n(\mathbf{y}|f_{\mathcal{Q}^c}(m_{\mathcal{Q}^c}), \mathbf{x}_{\mathcal{Q}}, f_{\mathcal{Q}'\setminus\mathcal{Q}}(m'_{\mathcal{Q}'\setminus\mathcal{Q}}), f_{\mathcal{T}}(m'_{\mathcal{T}})) \\
& \leq \sum_{\mathcal{Q}' \in \mathcal{A}} \sum_{\substack{P_{X_{\mathcal{Q}^c}X_{\mathcal{Q}}X'_{\mathcal{T}}X'_{\mathcal{Q}'\setminus\mathcal{Q}},X'_{\mathcal{Q}'},Y} \\ \mathcal{P}_{X_{\mathcal{Q}^c}X_{\mathcal{Q}}X'_{\mathcal{T}}X'_{\mathcal{Q}'\setminus\mathcal{Q}},X'_{\mathcal{Q}'},Y}^2}} \exp \left\{ n(|\mathcal{Q} \setminus \mathcal{Q}'| + |\mathcal{T}|)R - I(Y; X'_{\mathcal{Q}'\setminus\mathcal{Q}}, X'_{\mathcal{T}}|X_{\mathcal{Q}^c}X_{\mathcal{Q}}) + \epsilon \right\} \\
& = \sum_{\mathcal{Q}' \in \mathcal{A}} \sum_{\substack{P_{X_{\mathcal{Q}^c}X_{\mathcal{Q}}X'_{\mathcal{T}}X'_{\mathcal{Q}'\setminus\mathcal{Q}},X'_{\mathcal{Q}'},Y} \\ \mathcal{P}_{X_{\mathcal{Q}^c}X_{\mathcal{Q}}X'_{\mathcal{T}}X'_{\mathcal{Q}'\setminus\mathcal{Q}},X'_{\mathcal{Q}'},Y}^2}} \exp \left\{ n(|\mathcal{Q} \setminus \mathcal{Q}'| + |\mathcal{T}|)R - I(X_{\mathcal{Q}^c}Y; X'_{\mathcal{Q}'\setminus\mathcal{Q}}, X'_{\mathcal{T}}|X_{\mathcal{Q}}) + I(X_{\mathcal{Q}^c}; X'_{\mathcal{Q}'\setminus\mathcal{Q}}, X'_{\mathcal{T}}|X_{\mathcal{Q}}) + \epsilon \right\}
\end{aligned}$$

From the definitions of $\mathcal{P}_{X_{\mathcal{Q}^c}X_{\mathcal{Q}}X'_{\mathcal{T}}X'_{\mathcal{Q}'\setminus\mathcal{Q}},X'_{\mathcal{Q}'},Y}^2$ and $\mathcal{P}_{X_{\mathcal{Q}^c}X_{\mathcal{Q}}X'_{\mathcal{T}}X'_{\mathcal{Q}'\setminus\mathcal{Q}},X'_{\mathcal{Q}'},Y}^1$, we not that $I(X_{\mathcal{Q}^c}Y; X'_{\mathcal{Q}'\setminus\mathcal{Q}}, X'_{\mathcal{T}}|X_{\mathcal{Q}}) \geq \eta$ and $I(X_{\mathcal{Q}^c}; X'_{\mathcal{Q}'\setminus\mathcal{Q}}, X'_{\mathcal{T}}|X_{\mathcal{Q}}) \leq |\mathcal{Q}^c|((|\mathcal{T}| + |(\mathcal{Q} \setminus \mathcal{Q}')|)R + \epsilon)$. This implies that

$$\begin{aligned}
& \sum_{\mathcal{Q}' \in \mathcal{A}} \sum_{\substack{P_{X_{\mathcal{Q}^c}X_{\mathcal{Q}}X'_{\mathcal{T}}X'_{\mathcal{Q}'\setminus\mathcal{Q}},X'_{\mathcal{Q}'},Y} \\ \mathcal{P}_{X_{\mathcal{Q}^c}X_{\mathcal{Q}}X'_{\mathcal{T}}X'_{\mathcal{Q}'\setminus\mathcal{Q}},X'_{\mathcal{Q}'},Y}^2}} \exp \left\{ n(|\mathcal{Q} \setminus \mathcal{Q}'| + |\mathcal{T}|)R - I(X_{\mathcal{Q}^c}Y; X'_{\mathcal{Q}'\setminus\mathcal{Q}}, X'_{\mathcal{T}}|X_{\mathcal{Q}}) + I(X_{\mathcal{Q}^c}; X'_{\mathcal{Q}'\setminus\mathcal{Q}}, X'_{\mathcal{T}}|X_{\mathcal{Q}}) + \epsilon \right\} \\
& \leq \sum_{\mathcal{Q}' \in \mathcal{A}} \sum_{\substack{P_{X_{\mathcal{Q}^c}X_{\mathcal{Q}}X'_{\mathcal{T}}X'_{\mathcal{Q}'\setminus\mathcal{Q}},X'_{\mathcal{Q}'},Y} \\ \mathcal{P}_{X_{\mathcal{Q}^c}X_{\mathcal{Q}}X'_{\mathcal{T}}X'_{\mathcal{Q}'\setminus\mathcal{Q}},X'_{\mathcal{Q}'},Y}^2}} \exp \{ n((|\mathcal{Q} \setminus \mathcal{Q}'| + |\mathcal{T}|)R - \eta + |\mathcal{Q}^c|((|\mathcal{T}| + |(\mathcal{Q} \setminus \mathcal{Q}')|)R + \epsilon) + \epsilon) \} \\
& \leq 2^k \sum_{\substack{P_{X_{\mathcal{Q}^c}X_{\mathcal{Q}}X'_{\mathcal{T}}X'_{\mathcal{Q}'\setminus\mathcal{Q}},X'_{\mathcal{Q}'},Y} \\ \mathcal{P}_{X_{\mathcal{Q}^c}X_{\mathcal{Q}}X'_{\mathcal{T}}X'_{\mathcal{Q}'\setminus\mathcal{Q}},X'_{\mathcal{Q}'},Y}^2}} \exp \{ n(kR - \eta + k(kR + \epsilon) + \epsilon) \} \\
& = 2^k \sum_{\substack{P_{X_{\mathcal{Q}^c}X_{\mathcal{Q}}X'_{\mathcal{T}}X'_{\mathcal{Q}'\setminus\mathcal{Q}},X'_{\mathcal{Q}'},Y} \\ \mathcal{P}_{X_{\mathcal{Q}^c}X_{\mathcal{Q}}X'_{\mathcal{T}}X'_{\mathcal{Q}'\setminus\mathcal{Q}},X'_{\mathcal{Q}'},Y}^2}} \exp \{ n((k + k^2)R - \eta + (k + 1)\epsilon) \} \\
& \rightarrow 0 \text{ for } R < \frac{\eta - (k + 1)\epsilon}{k + k^2}.
\end{aligned}$$

Since $\eta > (2k + 1)(k + 1)\epsilon$, $\frac{\eta - (k + 1)\epsilon}{k + k^2} > 2\epsilon$. Thus, we can choose R between ϵ and 2ϵ . \square

Proof of Lemma 17. This proof is along the lines of [10, Lemma 2] and [22, Lemma 3]. We will generate the codebooks

by a random experiment. For any $\mathcal{Q} \in \mathcal{A}$, $\mathbf{x}_{\mathcal{Q}} \in \mathcal{X}_{\mathcal{Q}}^n$ and joint type $P_{X_{\mathcal{Q}^c} X'_{\mathcal{T}} X'_{\mathcal{J}} X_{\mathcal{Q}}} \in \mathcal{P}_{\mathcal{X}_{\mathcal{Q}^c} \times \mathcal{X}_{\mathcal{T}} \times \mathcal{X}'_{\mathcal{J}} \times \mathcal{X}_{\mathcal{Q}}}^n$, we will show that the probability that statement (b) does not hold, falls doubly exponentially in n . We will only analyze statement (b) as choosing $\mathcal{T} = \mathcal{J} = \emptyset$ in (b) will also imply that the probability that (a) does not hold also falls doubly exponentially. Since \mathcal{A} , $|\mathcal{X}_{\mathcal{Q}^c}^n|$ and $|\mathcal{P}_{\mathcal{X}_{\mathcal{Q}^c} \times \mathcal{X}_{\mathcal{T}} \times \mathcal{X}'_{\mathcal{J}} \times \mathcal{X}_{\mathcal{Q}}}^n|$ grow at most exponentially in n , a union bound will imply the existence of codebooks satisfying (a) and (b). The proof will use [22, Lemma A1] which we restate here for a quick reference.

Lemma 18. [22, Lemma A1] Let $\mathbf{Z}_1, \dots, \mathbf{Z}_N$ be arbitrary random variables, and let $f_j(\mathbf{Z}_1, \dots, \mathbf{Z}_j)$ be arbitrary with $0 \leq f_j \leq 1$, $j = 1, \dots, N$. Then the condition

$$E[f_j(\mathbf{Z}_1, \dots, \mathbf{Z}_j) | \mathbf{Z}_1, \dots, \mathbf{Z}_{j-1}] \leq a, \quad j \in [1 : N],$$

implies that for any real number t ,

$$\mathbb{P} \left\{ \frac{1}{N} \sum_{j=1}^N f_j(\mathbf{Z}_1, \dots, \mathbf{Z}_j) > t \right\} \leq \exp \{-N(t - a \log e)\}.$$

Let T_i^n , $i \in [1 : k]$ denote the type class of P_i . We generate independent random codebooks for each user. The codebook for user $i \in [1 : k]$, denoted by $\mathcal{C}_i = (\mathbf{X}_{i,1}, \mathbf{X}_{i,2}, \dots, \mathbf{X}_{i,N})$, consists of independent random vectors each distributed uniformly on T_i^n . Fix $\mathcal{Q} \in \mathcal{A}$, $\mathbf{x}_{\mathcal{Q}} \in \mathcal{X}_{\mathcal{Q}}^n$ and a joint type $P_{X_{\mathcal{Q}^c} X'_{\mathcal{T}} X'_{\mathcal{J}} X_{\mathcal{Q}}}$ such that for every $i \in \mathcal{Q}^c$, $P_{X_i} = P_i$, for $t \in \mathcal{T}$, $P_{X'_t} = P_t$ and for $j \in \mathcal{J}$, $P_{X'_j} = P_j$ and $\mathbf{x}_{\mathcal{Q}} \in T_{X_{\mathcal{Q}}}^n$. We will analyze the probability that (b) does not hold under the randomness of codebook generation process. Note that the bound in (b) is non-trivial only when $\mathcal{Q}^c \neq \emptyset$. For any $l \in \mathcal{Q}^c$,

$$\begin{aligned} & \mathbb{P} \left(\frac{1}{N^{|\mathcal{Q}^c|}} |\{m_{\mathcal{Q}^c} \in \mathcal{M}_{\mathcal{Q}^c} : \exists m'_{\mathcal{T}} \in \mathcal{M}_{\mathcal{T}}, m'_i \neq m_i \text{ for all } i \in \mathcal{T}, m'_{\mathcal{J}} \in \mathcal{M}_{\mathcal{J}}, \right. \\ & \quad \left. (\mathbf{X}_{\mathcal{Q}^c, m_{\mathcal{Q}^c}}, \mathbf{X}_{\mathcal{T}, m'_{\mathcal{T}}}, \mathbf{X}_{\mathcal{J}, m'_{\mathcal{J}}}, \mathbf{x}_{\mathcal{Q}}) \in T_{X_{\mathcal{Q}^c} X'_{\mathcal{T}} X'_{\mathcal{J}} X_{\mathcal{Q}}}^n\} | > \exp \{-n\epsilon/2\} \right) \\ &= \mathbb{P} \left(\sum_{m_{\mathcal{Q}^c \setminus \{l\}} \in \mathcal{M}_{\mathcal{Q}^c \setminus \{l\}}} \frac{1}{N} |\{m_l \in \mathcal{M}_l : \exists m'_{\mathcal{T}} \in \mathcal{M}_{\mathcal{T}}, m'_i \neq m_i \text{ for all } i \in \mathcal{T}, m'_{\mathcal{J}} \in \mathcal{M}_{\mathcal{J}}, \right. \\ & \quad \left. (\mathbf{X}_{\mathcal{Q}^c, m_{\mathcal{Q}^c}}, \mathbf{X}_{\mathcal{T}, m'_{\mathcal{T}}}, \mathbf{X}_{\mathcal{J}, m'_{\mathcal{J}}}, \mathbf{x}_{\mathcal{Q}}) \in T_{X_{\mathcal{Q}^c} X'_{\mathcal{T}} X'_{\mathcal{J}} X_{\mathcal{Q}}}^n\} | > N^{|\mathcal{Q}^c| - 1} \exp \{-n\epsilon/2\} \right) \\ &\leq \sum_{m_{\mathcal{Q}^c \setminus \{l\}} \in \mathcal{M}_{\mathcal{Q}^c \setminus \{l\}}} \mathbb{P} \left(\frac{1}{N} |\{m_l \in \mathcal{M}_l : \exists m'_{\mathcal{T}} \in \mathcal{M}_{\mathcal{T}}, m'_i \neq m_i \text{ for all } i \in \mathcal{T}, m'_{\mathcal{J}} \in \mathcal{M}_{\mathcal{J}}, \right. \\ & \quad \left. (\mathbf{X}_{\mathcal{Q}^c, m_{\mathcal{Q}^c}}, \mathbf{X}_{\mathcal{T}, m'_{\mathcal{T}}}, \mathbf{X}_{\mathcal{J}, m'_{\mathcal{J}}}, \mathbf{x}_{\mathcal{Q}}) \in T_{X_{\mathcal{Q}^c} X'_{\mathcal{T}} X'_{\mathcal{J}} X_{\mathcal{Q}}}^n\} | > \exp \{-n\epsilon/2\} \right) \\ &\leq \sum_{\substack{m_{\mathcal{Q}^c \setminus \{l\}} \\ \in \mathcal{M}_{\mathcal{Q}^c \setminus \{l\}}}} \left(\sum_{\substack{\mathbf{x}_{\mathcal{Q}^c \setminus \{l\}} \\ \in T_{X_{\mathcal{Q}^c \setminus \{l\}} | X_{\mathcal{Q}}}^n(\mathbf{x}_{\mathcal{Q}})}} \mathbb{P}(\mathbf{X}_{\mathcal{Q}^c \setminus \{l\}, m_{\mathcal{Q}^c \setminus \{l\}}} = \mathbf{x}_{\mathcal{Q}^c \setminus \{l\}}) \mathbb{P} \left(\frac{1}{N} |\{m_l \in \mathcal{M}_l : \exists m'_{\mathcal{T}} \in \mathcal{M}_{\mathcal{T}}, m'_i \neq m_i \text{ for all } i \in \mathcal{T}, \right. \right. \\ & \quad \left. \left. m'_{\mathcal{J}} \in \mathcal{M}_{\mathcal{J}} : (\mathbf{X}_{l, m_l}, \mathbf{x}_{\mathcal{Q}^c \setminus \{l\}}, \mathbf{X}_{\mathcal{T}, m'_{\mathcal{T}}}, \mathbf{X}_{\mathcal{J}, m'_{\mathcal{J}}}, \mathbf{x}_{\mathcal{Q}}) \in T_{X_{\mathcal{Q}^c} X'_{\mathcal{T}} X'_{\mathcal{J}} X_{\mathcal{Q}}}^n\} | > \exp \{-n\epsilon/2\} \right) \right). \end{aligned} \quad (147)$$

To analyze this, we first consider the case when $\mathcal{T} \neq \emptyset$. Recall that $\mathcal{T} \subseteq \mathcal{Q}^c$. Without loss of generality, suppose $1 \in \mathcal{Q}^c \cap \mathcal{T}$. Then for $l = 1$, we note that

$$\mathbb{P} \left(\frac{1}{N} |\{m_1 \in \mathcal{M}_1 : \exists m'_{\mathcal{T}} \in \mathcal{M}_{\mathcal{T}}, m'_t \neq m_t \text{ for all } t \in \mathcal{T}, m'_{\mathcal{J}} \in \mathcal{M}_{\mathcal{J}}, \right. \\ \left. (\mathbf{X}_{1, m_1}, \mathbf{x}_{\mathcal{Q}^c \setminus \{1\}}, \mathbf{X}_{\mathcal{T}, m'_{\mathcal{T}}}, \mathbf{X}_{\mathcal{J}, m'_{\mathcal{J}}}, \mathbf{x}_{\mathcal{Q}}) \in T_{X_{\mathcal{Q}^c} X'_{\mathcal{T}} X'_{\mathcal{J}} X_{\mathcal{Q}}}^n\} | > \exp \{-n\epsilon/2\} \right).$$

$$\begin{aligned}
&= \mathbb{P}\left(\frac{1}{N}|j \in \mathcal{M}_1 : \exists i < j, i \in \mathcal{M}_1, m'_{\mathcal{T} \setminus \{1\}} \in \mathcal{M}_{\mathcal{T} \setminus \{1\}}, m'_t \neq m_t \text{ for all } t \in \mathcal{T} \setminus \{1\}, m'_{\mathcal{J}} \in \mathcal{M}_{\mathcal{J}}, \right. \\
&\quad \left. ((\mathbf{X}_{1,j}, \mathbf{x}_{\mathcal{Q}^c \setminus \{1\}}), (\mathbf{X}_{1,i}, \mathbf{X}_{\mathcal{T} \setminus \{1\}, m'_{\mathcal{T} \setminus \{1\}}}), \mathbf{X}_{\mathcal{J}, m'_{\mathcal{J}}}, \mathbf{x}_{\mathcal{Q}}) \in T_{X_{\mathcal{Q}^c}^n X'_{\mathcal{T}} X'_{\mathcal{J}} X_{\mathcal{Q}}} \right) \\
&\quad + \frac{1}{N}|j \in \mathcal{M}_1 : \exists i > j, i \in \mathcal{M}_1, m'_{\mathcal{T} \setminus \{1\}} \in \mathcal{M}_{\mathcal{T} \setminus \{1\}}, m'_t \neq m_t \text{ for all } t \in \mathcal{T} \setminus \{1\}, m'_{\mathcal{J}} \in \mathcal{M}_{\mathcal{J}}, \\
&\quad \left. ((\mathbf{X}_{1,j}, \mathbf{x}_{\mathcal{Q}^c \setminus \{1\}}), (\mathbf{X}_{1,i}, \mathbf{X}_{\mathcal{T} \setminus \{1\}, m'_{\mathcal{T} \setminus \{1\}}}), \mathbf{X}_{\mathcal{J}, m'_{\mathcal{J}}}, \mathbf{x}_{\mathcal{Q}}) \in T_{X_{\mathcal{Q}^c}^n X'_{\mathcal{T}} X'_{\mathcal{J}} X_{\mathcal{Q}}}\right\} > \exp\{-n\epsilon/2\} \Big). \\
&\leq \mathbb{P}\left(\frac{1}{N}|j \in \mathcal{M}_1 : \exists i < j, i \in \mathcal{M}_1, m'_{\mathcal{T} \setminus \{1\}} \in \mathcal{M}_{\mathcal{T} \setminus \{1\}}, m'_t \neq m_t \text{ for all } t \in \mathcal{T} \setminus \{1\}, m'_{\mathcal{J}} \in \mathcal{M}_{\mathcal{J}}, \right. \\
&\quad \left. ((\mathbf{X}_{1,j}, \mathbf{x}_{\mathcal{Q}^c \setminus \{1\}}), (\mathbf{X}_{1,i}, \mathbf{X}_{\mathcal{T} \setminus \{1\}, m'_{\mathcal{T} \setminus \{1\}}}), \mathbf{X}_{\mathcal{J}, m'_{\mathcal{J}}}, \mathbf{x}_{\mathcal{Q}}) \in T_{X_{\mathcal{Q}^c}^n X'_{\mathcal{T}} X'_{\mathcal{J}} X_{\mathcal{Q}}}\right\} > \frac{1}{2} \exp\{-n\epsilon/2\} \Big) \quad (148) \\
&\quad + \mathbb{P}\left(\frac{1}{N}|j \in \mathcal{M}_1 : \exists i > j, i \in \mathcal{M}_1, m'_{\mathcal{T} \setminus \{1\}} \in \mathcal{M}_{\mathcal{T} \setminus \{1\}}, m'_t \neq m_t \text{ for all } t \in \mathcal{T} \setminus \{1\}, m'_{\mathcal{J}} \in \mathcal{M}_{\mathcal{J}}, \right. \\
&\quad \left. ((\mathbf{X}_{1,j}, \mathbf{x}_{\mathcal{Q}^c \setminus \{1\}}), (\mathbf{X}_{1,i}, \mathbf{X}_{\mathcal{T} \setminus \{1\}, m'_{\mathcal{T} \setminus \{1\}}}), \mathbf{X}_{\mathcal{J}, m'_{\mathcal{J}}}, \mathbf{x}_{\mathcal{Q}}) \in T_{X_{\mathcal{Q}^c}^n X'_{\mathcal{T}} X'_{\mathcal{J}} X_{\mathcal{Q}}}\right\} > \frac{1}{2} \exp\{-n\epsilon/2\} \Big). \quad (149)
\end{aligned}$$

We will now analyze (148) using Lemma 18. For $j \in [1 : N]$, let $\mathbf{Z}_j = (\mathbf{X}_{1,j}, \mathcal{C}_{[2:k]})$ where the codewords for $m_{\mathcal{Q}^c \setminus \{i\}}$ are fixed to $\mathbf{x}_{\mathcal{Q}^c \setminus \{1\}}$. Let $f_j^{\mathbf{x}_{\mathcal{Q}^c \setminus \{1\}}}(\mathbf{Z}_1, \dots, \mathbf{Z}_j)$ be defined as

$$\begin{aligned}
f_j^{\mathbf{x}_{\mathcal{Q}^c \setminus \{1\}}}(\mathbf{Z}_1, \dots, \mathbf{Z}_j) &= f_j^{\mathbf{x}_{\mathcal{Q}^c \setminus \{1\}}}((\mathbf{X}_{1,1}, \mathcal{C}_{[2:k]}), \dots, (\mathbf{X}_{1,j}, \mathcal{C}_{[2:k]})) \\
&= \begin{cases} 1, & \text{if } \exists i < j, (m'_{\mathcal{T} \setminus \{1\}}, m'_{\mathcal{J}}) \in \mathcal{M}_{\mathcal{T} \setminus \{1\}} \times \mathcal{M}_{\mathcal{J}} \text{ such that } \forall t \in \mathcal{T} \setminus \{1\}, m'_t \neq m_t, \\ & ((\mathbf{X}_{1,j}, \mathbf{x}_{\mathcal{Q}^c \setminus \{1\}}), (\mathbf{X}_{1,i}, \mathbf{X}_{(\mathcal{T} \setminus \{1\}, m'_{\mathcal{T} \setminus \{1\}})}), \mathbf{X}_{(\mathcal{J}, m'_{\mathcal{J}})}, \mathbf{x}_{\mathcal{Q}}) \in T_{X_{\mathcal{Q}^c}^n X'_{\mathcal{T}} X'_{\mathcal{J}} X_{\mathcal{Q}}}, \\ 0, & \text{otherwise.} \end{cases}
\end{aligned}$$

For $t = \frac{1}{2} \exp\{-n\epsilon/2\}$, (148) can be written as

$$\left(\frac{1}{N} \sum_{j=1}^N f_j^{\mathbf{x}_{\mathcal{Q}^c \setminus \{1\}}}(\mathbf{Z}_1, \dots, \mathbf{Z}_j) > t \right)$$

We will compute a in Lemma 18.

$$\begin{aligned}
&\mathbb{E} \left[f_j^{\mathbf{x}_{\mathcal{Q}^c \setminus \{1\}}}((\mathbf{X}_{1,1}, \mathcal{C}_{[2:k]}), \dots, (\mathbf{X}_{1,j}, \mathcal{C}_{[2:k]})) | (\mathbf{X}_{1,1}, \mathcal{C}_{[2:k]}), \dots, (\mathbf{X}_{1,(j-1)}, \mathcal{C}_{[2:k]}) \right] \\
&\leq \sum_{\substack{i \in \mathcal{M}_1, i < j \\ (m'_{\mathcal{T} \setminus \{1\}}, m'_{\mathcal{J}}) \in \mathcal{M}_{\mathcal{T} \setminus \{1\}} \times \mathcal{M}_{\mathcal{J}} \\ m'_t \neq m_t, t \in \mathcal{T} \setminus \{1\}}} \mathbb{P} \left(((\mathbf{X}_{1,j}, \mathbf{x}_{\mathcal{Q}^c \setminus \{1\}}), (\mathbf{X}_{1,i}, \mathbf{X}_{(\mathcal{T} \setminus \{1\}, m'_{\mathcal{T} \setminus \{1\}})}), \mathbf{X}_{(\mathcal{J}, m'_{\mathcal{J}})}, \mathbf{x}_{\mathcal{Q}}) \in T_{X_{\mathcal{Q}^c}^n X'_{\mathcal{T}} X'_{\mathcal{J}} X_{\mathcal{Q}}} \right) \\
&\quad \left| (\mathbf{X}_{1,1}, \mathcal{C}_{[2:k]}), \dots, (\mathbf{X}_{1,(j-1)}, \mathcal{C}_{[2:k]}) \right) \\
&\leq N^{(|\mathcal{T}|+|\mathcal{J}|)} \frac{\exp\{nH(X_1 | X_{\mathcal{Q}^c \setminus \{1\}} X'_{\mathcal{T}} X'_{\mathcal{J}} X_{\mathcal{Q}})\}}{(n+1)^{-|\mathcal{X}_1|} \exp\{nH(X_1)\}} \\
&= (n+1)^{|\mathcal{X}_1|} \exp\{n((|\mathcal{T}|+|\mathcal{J}|)(1/n) \log_2 N - I(X_1; X_{\mathcal{Q}^c \setminus \{1\}} X'_{\mathcal{T}} X'_{\mathcal{J}} X_{\mathcal{Q}}))\}
\end{aligned}$$

Suppose $I(X_1; X_{\mathcal{Q}^c \setminus \{1\}} X'_{\mathcal{T}} X'_{\mathcal{J}} X_{\mathcal{Q}}) > (|\mathcal{T}|+|\mathcal{J}|)(1/n) \log_2 N + \epsilon$. Then, $a = (n+1)^{|\mathcal{X}_1|} \exp\{-n\epsilon\}$. Thus,

$$\left(\frac{1}{N} \sum_{j=1}^N f_j^{\mathbf{x}_{\mathcal{Q}^c \setminus \{1\}}}(\mathbf{Z}_1, \dots, \mathbf{Z}_j) > t \right)$$

$$\begin{aligned}
&\leq \exp\{-N(t - a \log_2 e)\} \\
&= \exp\left\{-N\left(\frac{1}{2} \exp\{-n\epsilon/2\} - (n+1)^{|\mathcal{X}_1|} \exp\{-n\epsilon\}\right)\right\} \\
&\leq \exp\left\{\left(-\frac{1}{2} \exp\{n\epsilon/2\} + (n+1)^{|\mathcal{X}_1|}\right)\right\} \text{ because } N \leq \exp\{n\epsilon\}.
\end{aligned}$$

Thus, (148) falls doubly exponentially. Since (149) is symmetric to (148), we can obtain the same upper bound for (149) as well. This implies that (147) falls doubly exponentially when $\mathcal{T} \neq \emptyset$. Now, we consider the case when $\mathcal{T} = \emptyset$. In this case, in order to show that (147) falls doubly exponentially, we need to show that

$$\mathbb{P}\left(\frac{1}{N} |\{m_l \in \mathcal{M}_l : \exists m'_{\mathcal{J}} \in \mathcal{M}_{\mathcal{J}}, (\mathbf{X}_{l,m_l}, \mathbf{x}_{\mathcal{Q}^c \setminus \{l\}}, \mathbf{X}_{\mathcal{J}, m'_{\mathcal{J}}}, \mathbf{x}_{\mathcal{Q}}) \in T_{X_{\mathcal{Q}^c}^n X'_{\mathcal{J}} X_{\mathcal{Q}}}\}| > \exp\{-n\epsilon/2\}\right) \quad (150)$$

falls doubly exponentially. This can be shown in a similar manner as the previous case. Again, without loss of generality, suppose $l = 1$. Let $Z_j = (\mathbf{X}_{1,j}, \mathcal{C}_{[2:k]})$, $j \in [1 : N]$, where the codewords $\mathbf{x}_{\mathcal{Q}^c \setminus \{1\}}$ corresponding to messages $m_{\mathcal{Q}^c \setminus \{1\}}$ are fixed. Let $g_j^{\mathbf{x}_{\mathcal{Q}^c \setminus \{1\}}}(\mathbf{Z}_1, \dots, \mathbf{Z}_j)$ be defined as

$$\begin{aligned}
g_j^{\mathbf{x}_{\mathcal{Q}^c \setminus \{1\}}}(\mathbf{Z}_1, \dots, \mathbf{Z}_j) &= g_j^{\mathbf{x}_{\mathcal{Q}^c \setminus \{1\}}}((\mathbf{X}_{1,1}, \mathcal{C}_{[2:k]}) \dots, (\mathbf{X}_{1,j}, \mathcal{C}_{[2:k]})) \\
&= \begin{cases} 1, & \text{if } \exists m'_{\mathcal{J}} \in \mathcal{M}_{\mathcal{J}} \text{ such that } ((\mathbf{X}_{1,j}, \mathbf{x}_{\mathcal{Q}^c \setminus \{1\}}), \mathbf{X}_{(\mathcal{J}, m'_{\mathcal{J}})}, \mathbf{x}_{\mathcal{Q}}) \in T_{X_{\mathcal{Q}^c}^n X'_{\mathcal{J}} X_{\mathcal{Q}}}, \\ 0, & \text{otherwise.} \end{cases}
\end{aligned}$$

For $t = \exp\{-n\epsilon/2\}$, (150) is

$$\mathbb{P}\left(\frac{1}{N} \sum_{j=1}^N g_j^{\mathbf{x}_{\mathcal{Q}^c \setminus \{1\}}}(\mathbf{Z}_1, \dots, \mathbf{Z}_j) > t\right).$$

Computing a ,

$$\begin{aligned}
&\mathbb{E} [g_j^{\mathbf{x}_{\mathcal{Q}^c \setminus \{1\}}}((\mathbf{X}_{1,1}, \mathcal{C}_{[2:k]}) \dots, (\mathbf{X}_{1,j}, \mathcal{C}_{[2:k]})) | (\mathbf{X}_{1,1}, \mathcal{C}_{[2:k]}) \dots, (\mathbf{X}_{1,(j-1)}, \mathcal{C}_{[2:k]})] \\
&\leq \sum_{m'_{\mathcal{J}} \in \mathcal{M}_{\mathcal{J}}} \mathbb{P}\left(\left((\mathbf{X}_{1,j}, \mathbf{x}_{\mathcal{Q}^c \setminus \{1\}}), \mathbf{X}_{(\mathcal{J}, m'_{\mathcal{J}})}, \mathbf{x}_{\mathcal{Q}}\right) \in T_{X_{\mathcal{Q}^c}^n X'_{\mathcal{J}} X_{\mathcal{Q}}} | (\mathbf{X}_{1,1}, \mathcal{C}_{[2:k]}) \dots, (\mathbf{X}_{1,(j-1)}, \mathcal{C}_{[2:k]})\right) \\
&\leq N^{|\mathcal{J}|} \frac{\exp\{nH(X_1 | X_{\mathcal{Q}^c \setminus \{1\}} X'_{\mathcal{J}} X_{\mathcal{Q}})\}}{(n+1)^{|\mathcal{X}_1|} \exp\{nH(X_1)\}} \\
&= (n+1)^{|\mathcal{X}_1|} \exp\{n((|\mathcal{J}|)(1/n) \log_2 N - I(X_1; X_{\mathcal{Q}^c \setminus \{1\}} X'_{\mathcal{J}} X_{\mathcal{Q}}))\}
\end{aligned}$$

Suppose $I(X_1; X_{\mathcal{Q}^c \setminus \{1\}} X'_{\mathcal{J}} X_{\mathcal{Q}}) > (|\mathcal{J}|)(1/n) \log_2 N + \epsilon$. Then, $a = (n+1)^{|\mathcal{X}_1|} \exp\{-n\epsilon\}$. Thus,

$$\begin{aligned}
&\left(\frac{1}{N} \sum_{j=1}^N g_j^{\mathbf{x}_{\mathcal{Q}^c \setminus \{1\}}}(\mathbf{Z}_1, \dots, \mathbf{Z}_j) > t\right) \\
&\leq \exp\{-N(t - a \log_2 e)\} \\
&= \exp\left\{-N\left(\exp\{-n\epsilon/2\} - (n+1)^{|\mathcal{X}_1|} \exp\{-n\epsilon\}\right)\right\} \\
&\leq \exp\left\{-\left(\exp\{n\epsilon/2\} + (n+1)^{|\mathcal{X}_1|}\right)\right\}
\end{aligned}$$

which falls doubly exponentially. □

Lemma 19. Suppose the Byzantine MAC (W, \mathcal{A}) is not symmetrizable. Let $P_i \in \mathcal{P}_{\mathcal{X}_i}$, $i \in [1 : k]$ be distributions such that $P_i(x_i) > 0$, $x_i \in \mathcal{X}_i$, $i \in [1 : k]$. Let $f_i : \mathcal{M}_i \rightarrow T_{\mathcal{X}_i}^n$, $i \in [1 : k]$ be some encoding maps. There exists a choice of $\eta > 0$ such that if $(m_1, m_2, \dots, m_k) \neq (\tilde{m}_1, \tilde{m}_2, \dots, \tilde{m}_k)$, $\mathcal{D}_{m_1, m_2, \dots, m_k} \cap \mathcal{D}_{\tilde{m}_1, \tilde{m}_2, \dots, \tilde{m}_k} = \emptyset$.

Proof. Suppose for $(\hat{m}_1, \hat{m}_2, \dots, \hat{m}_k) \neq (\bar{m}_1, \bar{m}_2, \dots, \bar{m}_k)$, there exists $\mathbf{y} \in \mathcal{D}_{\hat{m}_1, \hat{m}_2, \dots, \hat{m}_k} \cap \mathcal{D}_{\bar{m}_1, \bar{m}_2, \dots, \bar{m}_k}$. This implies that there exists $\gamma \in [1 : k]$ such that $\mathbf{y} \in \mathcal{D}_{\hat{m}_\gamma}^{(\gamma)} \cap \mathcal{D}_{\bar{m}_\gamma}^{(\gamma)}$ for $\hat{m}_\gamma \neq \bar{m}_\gamma$. Then, by the decoder definition, there exist $\mathcal{Q}, \tilde{\mathcal{Q}} \in \mathcal{A}$, not necessarily distinct, with $\gamma \notin \mathcal{Q}, \tilde{\mathcal{Q}}$; $\mathbf{x}_{\mathcal{Q}} \in \mathcal{X}_{\mathcal{Q}}^n$, $\tilde{\mathbf{x}}_{\tilde{\mathcal{Q}}} \in \mathcal{X}_{\tilde{\mathcal{Q}}}^n$; $m_{\mathcal{Q}} \in \mathcal{M}_{\mathcal{Q}^c}$; $\tilde{m}_{\tilde{\mathcal{Q}}} \in \mathcal{M}_{\tilde{\mathcal{Q}}^c}$ with $m_\gamma = \hat{m}_\gamma$ and $\tilde{m}_\gamma = \bar{m}_\gamma$ such that for $\mathcal{T} := \{i \in (\mathcal{Q} \cup \tilde{\mathcal{Q}})^c : m_i \neq \tilde{m}_i\}$ (note that $\gamma \in \mathcal{T}$), and for the joint distributions $P_{X_{\mathcal{T}} X_{\tilde{\mathcal{Q}} \setminus \mathcal{Q}} X'_{(\mathcal{T} \cup \mathcal{Q} \cup \tilde{\mathcal{Q}})^c} X_{\mathcal{Q}} Y}$ and $P_{\tilde{X}_{\mathcal{T}} \tilde{X}_{\tilde{\mathcal{Q}} \setminus \tilde{\mathcal{Q}}} X'_{(\mathcal{T} \cup \mathcal{Q} \cup \tilde{\mathcal{Q}})^c} \tilde{X}_{\tilde{\mathcal{Q}}} Y}$ defined by

$(f_{\mathcal{T}}(m_{\mathcal{T}}), f_{\tilde{\mathcal{Q}} \setminus \mathcal{Q}}(m_{\tilde{\mathcal{Q}} \setminus \mathcal{Q}}), f_{(\mathcal{T} \cup \mathcal{Q} \cup \tilde{\mathcal{Q}})^c}(m_{(\mathcal{T} \cup \mathcal{Q} \cup \tilde{\mathcal{Q}})^c}), \mathbf{x}_{\mathcal{Q}}, \mathbf{y}) \in T_{X_{\mathcal{T}} X_{\tilde{\mathcal{Q}} \setminus \mathcal{Q}} X'_{(\mathcal{T} \cup \mathcal{Q} \cup \tilde{\mathcal{Q}})^c} X_{\mathcal{Q}} Y}^n$ and $(f_{\mathcal{T}}(\tilde{m}_{\mathcal{T}}), f_{\tilde{\mathcal{Q}} \setminus \tilde{\mathcal{Q}}}(m_{\tilde{\mathcal{Q}} \setminus \tilde{\mathcal{Q}}}), f_{(\mathcal{T} \cup \mathcal{Q} \cup \tilde{\mathcal{Q}})^c}(m_{(\mathcal{T} \cup \mathcal{Q} \cup \tilde{\mathcal{Q}})^c}), \tilde{\mathbf{x}}_{\tilde{\mathcal{Q}}}, \mathbf{y}) \in T_{\tilde{X}_{\mathcal{T}} \tilde{X}_{\tilde{\mathcal{Q}} \setminus \tilde{\mathcal{Q}}} X'_{(\mathcal{T} \cup \mathcal{Q} \cup \tilde{\mathcal{Q}})^c} \tilde{X}_{\tilde{\mathcal{Q}}} Y}^n$ respectively, the following holds.

$$D \left(P_{X_{\mathcal{T}} X_{\tilde{\mathcal{Q}} \setminus \mathcal{Q}} X'_{(\mathcal{T} \cup \mathcal{Q} \cup \tilde{\mathcal{Q}})^c} X_{\mathcal{Q}} Y} \left\| \left(\prod_{i \in \mathcal{T}} P_i \right) \left(\prod_{j \in \tilde{\mathcal{Q}} \setminus \mathcal{Q}} P_j \right) \left(\prod_{l \in (\mathcal{T} \cup \mathcal{Q} \cup \tilde{\mathcal{Q}})^c} P_l \right) P_{X_{\mathcal{Q}}} W \right) < \eta, \quad (151)$$

$$D \left(P_{\tilde{X}_{\mathcal{T}} \tilde{X}_{\tilde{\mathcal{Q}} \setminus \tilde{\mathcal{Q}}} X'_{(\mathcal{T} \cup \mathcal{Q} \cup \tilde{\mathcal{Q}})^c} \tilde{X}_{\tilde{\mathcal{Q}}} Y} \left\| \left(\prod_{i \in \mathcal{T}} P_i \right) \left(\prod_{j \in \tilde{\mathcal{Q}} \setminus \tilde{\mathcal{Q}}} P_j \right) \left(\prod_{l \in (\mathcal{T} \cup \mathcal{Q} \cup \tilde{\mathcal{Q}})^c} P_l \right) P_{\tilde{X}_{\tilde{\mathcal{Q}}}} W \right) < \eta. \quad (152)$$

Then, the decoding condition 2 implies that

$$I(X_{\mathcal{T}} X_{\tilde{\mathcal{Q}} \setminus \mathcal{Q}} X'_{(\mathcal{T} \cup \mathcal{Q} \cup \tilde{\mathcal{Q}})^c} Y; \tilde{X}_{\mathcal{T}} \tilde{X}_{\tilde{\mathcal{Q}} \setminus \tilde{\mathcal{Q}}} | X_{\mathcal{Q}}) < \eta, \quad (153)$$

$$I(\tilde{X}_{\mathcal{T}} \tilde{X}_{\tilde{\mathcal{Q}} \setminus \tilde{\mathcal{Q}}} X'_{(\mathcal{T} \cup \mathcal{Q} \cup \tilde{\mathcal{Q}})^c} Y; X_{\mathcal{T}} X_{\tilde{\mathcal{Q}} \setminus \mathcal{Q}} | \tilde{X}_{\tilde{\mathcal{Q}}}) < \eta. \quad (154)$$

For ease of notation, let $\mathcal{H} := (\mathcal{T} \cup \mathcal{Q} \cup \tilde{\mathcal{Q}})^c$. From (152), by the chain rule of relative entropy, we get $D(P_{\tilde{X}_{\mathcal{T}} \tilde{X}_{\tilde{\mathcal{Q}} \setminus \tilde{\mathcal{Q}}} X'_{(\mathcal{T} \cup \mathcal{Q} \cup \tilde{\mathcal{Q}})^c} Y} \| (\prod_{i \in \mathcal{T}} P_i) (\prod_{j \in \tilde{\mathcal{Q}} \setminus \tilde{\mathcal{Q}}} P_j)) < \eta$. Using this, (151) and (153), we get

$$\begin{aligned} 3\eta &> D(P_{X_{\mathcal{T}} X_{\tilde{\mathcal{Q}} \setminus \mathcal{Q}} X'_{\mathcal{H}} X_{\mathcal{Q}} Y} \| (\prod_{i \in \mathcal{T}} P_i) (\prod_{j \in \tilde{\mathcal{Q}} \setminus \mathcal{Q}} P_j) (\prod_{l \in \mathcal{H}} P_l) P_{X_{\mathcal{Q}}} W) + D(P_{\tilde{X}_{\mathcal{T}} \tilde{X}_{\tilde{\mathcal{Q}} \setminus \tilde{\mathcal{Q}}} X'_{\mathcal{H}} Y} \| (\prod_{i \in \mathcal{T}} P_i) (\prod_{j \in \tilde{\mathcal{Q}} \setminus \tilde{\mathcal{Q}}} P_j)) \\ &\quad + I(X_{\mathcal{T}} X_{\tilde{\mathcal{Q}} \setminus \mathcal{Q}} X'_{\mathcal{H}} Y; \tilde{X}_{\mathcal{T}} \tilde{X}_{\tilde{\mathcal{Q}} \setminus \tilde{\mathcal{Q}}} | X_{\mathcal{Q}}) \\ &= D(P_{X_{\mathcal{T}} X_{\tilde{\mathcal{Q}} \setminus \mathcal{Q}} X'_{\mathcal{H}} X_{\mathcal{Q}} Y} \| (\prod_{i \in \mathcal{T}} P_i) (\prod_{j \in \tilde{\mathcal{Q}} \setminus \mathcal{Q}} P_j) (\prod_{l \in \mathcal{H}} P_l) P_{X_{\mathcal{Q}}} W) + D(P_{\tilde{X}_{\mathcal{T}} \tilde{X}_{\tilde{\mathcal{Q}} \setminus \tilde{\mathcal{Q}}} X'_{\mathcal{H}} Y} \| (\prod_{i \in \mathcal{T}} P_i) (\prod_{j \in \tilde{\mathcal{Q}} \setminus \tilde{\mathcal{Q}}} P_j)) \\ &\quad + D(P_{X_{\mathcal{T}} X_{\tilde{\mathcal{Q}} \setminus \mathcal{Q}} X'_{\mathcal{H}} X_{\mathcal{Q}} \tilde{X}_{\mathcal{T}} \tilde{X}_{\tilde{\mathcal{Q}} \setminus \tilde{\mathcal{Q}}} Y} \| P_{\tilde{X}_{\mathcal{T}} \tilde{X}_{\tilde{\mathcal{Q}} \setminus \tilde{\mathcal{Q}}}} P_{X_{\mathcal{Q}} | \tilde{X}_{\mathcal{T}} \tilde{X}_{\tilde{\mathcal{Q}} \setminus \tilde{\mathcal{Q}}}} P_{X_{\mathcal{T}} X_{\tilde{\mathcal{Q}} \setminus \mathcal{Q}} X'_{\mathcal{H}} Y | X_{\mathcal{Q}}}) \\ &= D \left(P_{X_{\mathcal{T}} X_{\tilde{\mathcal{Q}} \setminus \mathcal{Q}} X'_{\mathcal{H}} X_{\mathcal{Q}} \tilde{X}_{\mathcal{T}} \tilde{X}_{\tilde{\mathcal{Q}} \setminus \tilde{\mathcal{Q}}} Y} \| (\prod_{i \in \mathcal{T}} P_i) (\prod_{j \in \tilde{\mathcal{Q}} \setminus \mathcal{Q}} P_j) (\prod_{l \in \mathcal{H}} P_l) (\prod_{i \in \mathcal{T}} P_i) (\prod_{j \in \tilde{\mathcal{Q}} \setminus \tilde{\mathcal{Q}}} P_j) P_{X_{\mathcal{Q}} | \tilde{X}_{\mathcal{T}} \tilde{X}_{\tilde{\mathcal{Q}} \setminus \tilde{\mathcal{Q}}}} W_{Y | X_{\mathcal{T}} X_{\tilde{\mathcal{Q}} \setminus \mathcal{Q}} X'_{\mathcal{H}} X_{\mathcal{Q}}} \right) \\ &\stackrel{(b)}{\geq} D \left(P_{X_{\mathcal{T}} X_{\tilde{\mathcal{Q}} \setminus \mathcal{Q}} X'_{\mathcal{H}} \tilde{X}_{\mathcal{T}} \tilde{X}_{\tilde{\mathcal{Q}} \setminus \tilde{\mathcal{Q}}} Y} \| (\prod_{i \in \mathcal{T}} P_i) (\prod_{j \in \tilde{\mathcal{Q}} \setminus \tilde{\mathcal{Q}}} P_j) (\prod_{l \in \mathcal{H}} P_l) (\prod_{i \in \mathcal{T}} P_i) (\prod_{j \in \tilde{\mathcal{Q}} \setminus \tilde{\mathcal{Q}}} P_j) V_{Y | X_{\mathcal{T}} X_{\tilde{\mathcal{Q}} \setminus \mathcal{Q}} X'_{\mathcal{H}} \tilde{X}_{\mathcal{T}} \tilde{X}_{\tilde{\mathcal{Q}} \setminus \tilde{\mathcal{Q}}}} \right) \end{aligned}$$

where $V_{Y | X_{\mathcal{T}} X_{\tilde{\mathcal{Q}} \setminus \mathcal{Q}} X'_{\mathcal{H}} \tilde{X}_{\mathcal{T}} \tilde{X}_{\tilde{\mathcal{Q}} \setminus \tilde{\mathcal{Q}}}}(y | x_{\mathcal{T}}, x_{\tilde{\mathcal{Q}} \setminus \mathcal{Q}}, x'_{\mathcal{H}}, \tilde{x}_{\mathcal{T}}, \tilde{x}_{\tilde{\mathcal{Q}} \setminus \tilde{\mathcal{Q}}}) = \sum_{x_{\mathcal{Q}}} P_{X_{\mathcal{Q}} | \tilde{X}_{\mathcal{T}} \tilde{X}_{\tilde{\mathcal{Q}} \setminus \tilde{\mathcal{Q}}}}(x_{\mathcal{Q}} | \tilde{x}_{\mathcal{T}}, \tilde{x}_{\tilde{\mathcal{Q}} \setminus \tilde{\mathcal{Q}}}) W(y | x_{\mathcal{T}}, x_{\tilde{\mathcal{Q}} \setminus \mathcal{Q}}, x'_{\mathcal{H}}, x_{\mathcal{Q}})$,

and (b) follows from the chain rule of relative entropy. Using Pinsker's inequality, it follows that

$$\sum_{x_{\mathcal{T}}, x_{\tilde{\mathcal{Q}} \setminus \mathcal{Q}}, x'_{\mathcal{H}}, \tilde{x}_{\mathcal{T}}, \tilde{x}_{\tilde{\mathcal{Q}} \setminus \tilde{\mathcal{Q}}}, y} \left| P_{X_{\mathcal{T}} X_{\tilde{\mathcal{Q}} \setminus \mathcal{Q}} X'_{\mathcal{H}} \tilde{X}_{\mathcal{T}} \tilde{X}_{\tilde{\mathcal{Q}} \setminus \tilde{\mathcal{Q}}} Y}(x_{\mathcal{T}}, x_{\tilde{\mathcal{Q}} \setminus \mathcal{Q}}, x'_{\mathcal{H}}, \tilde{x}_{\mathcal{T}}, \tilde{x}_{\tilde{\mathcal{Q}} \setminus \tilde{\mathcal{Q}}}, y) \right|$$

$$\begin{aligned}
& - \left(\prod_{i \in \mathcal{T}} P_i(x_i) \right) \left(\prod_{j \in \bar{\mathcal{Q}} \setminus \mathcal{Q}} P_j(x_j) \right) \left(\prod_{l \in \mathcal{H}} P_l(x'_l) \right) \left(\prod_{i \in \mathcal{T}} P_l(\tilde{x}_l) \right) \left(\prod_{j \in \mathcal{Q} \setminus \bar{\mathcal{Q}}} P_j(\tilde{x}_j) \right) V_{Y|X_{\mathcal{T}} X_{\bar{\mathcal{Q}} \setminus \mathcal{Q}} X'_{\mathcal{H}} \tilde{X}_{\mathcal{T}} \tilde{X}_{\bar{\mathcal{Q}} \setminus \bar{\mathcal{Q}}}}(y|x_{\mathcal{T}}, x_{\bar{\mathcal{Q}} \setminus \mathcal{Q}}, x'_{\mathcal{H}}, \tilde{x}_{\mathcal{T}}, \tilde{x}_{\bar{\mathcal{Q}} \setminus \bar{\mathcal{Q}}}) \Big| \\
& \leq c\sqrt{3\eta}, \tag{155}
\end{aligned}$$

where c is some positive constant. By a symmetric analysis, we can show that

$$\begin{aligned}
& \sum_{x_{\mathcal{T}}, x_{\bar{\mathcal{Q}} \setminus \mathcal{Q}}, x'_{\mathcal{H}}, \tilde{x}_{\mathcal{T}}, \tilde{x}_{\bar{\mathcal{Q}} \setminus \bar{\mathcal{Q}}}, y} \left| P_{X_{\mathcal{T}} X_{\bar{\mathcal{Q}} \setminus \mathcal{Q}} X'_{\mathcal{H}} \tilde{X}_{\mathcal{T}} \tilde{X}_{\bar{\mathcal{Q}} \setminus \bar{\mathcal{Q}}}}(x_{\mathcal{T}}, x_{\bar{\mathcal{Q}} \setminus \mathcal{Q}}, x'_{\mathcal{H}}, \tilde{x}_{\mathcal{T}}, \tilde{x}_{\bar{\mathcal{Q}} \setminus \bar{\mathcal{Q}}}, y) \right. \\
& - \left. \left(\prod_{i \in \mathcal{T}} P_i(x_i) \right) \left(\prod_{j \in \bar{\mathcal{Q}} \setminus \mathcal{Q}} P_j(x_j) \right) \left(\prod_{l \in \mathcal{H}} P_l(x'_l) \right) \left(\prod_{i \in \mathcal{T}} P_l(\tilde{x}_l) \right) \left(\prod_{j \in \mathcal{Q} \setminus \bar{\mathcal{Q}}} P_j(\tilde{x}_j) \right) V'_{Y|X_{\mathcal{T}} X_{\bar{\mathcal{Q}} \setminus \mathcal{Q}} X'_{\mathcal{H}} \tilde{X}_{\mathcal{T}} \tilde{X}_{\bar{\mathcal{Q}} \setminus \bar{\mathcal{Q}}}}(y|x_{\mathcal{T}}, x_{\bar{\mathcal{Q}} \setminus \mathcal{Q}}, x'_{\mathcal{H}}, \tilde{x}_{\mathcal{T}}, \tilde{x}_{\bar{\mathcal{Q}} \setminus \bar{\mathcal{Q}}}) \right| \\
& \leq c\sqrt{3\eta}, \tag{156}
\end{aligned}$$

for

$$V'_{Y|X_{\mathcal{T}} X_{\bar{\mathcal{Q}} \setminus \mathcal{Q}} X'_{\mathcal{H}} \tilde{X}_{\mathcal{T}} \tilde{X}_{\bar{\mathcal{Q}} \setminus \bar{\mathcal{Q}}}}(y|x_{\mathcal{T}}, x_{\bar{\mathcal{Q}} \setminus \mathcal{Q}}, x'_{\mathcal{H}}, \tilde{x}_{\mathcal{T}}, \tilde{x}_{\bar{\mathcal{Q}} \setminus \bar{\mathcal{Q}}}) = \sum_{\tilde{x}_{\bar{\mathcal{Q}}}} P_{\tilde{X}_{\bar{\mathcal{Q}}}|X_{\mathcal{T}} X_{\bar{\mathcal{Q}} \setminus \mathcal{Q}}}(\tilde{x}_{\bar{\mathcal{Q}}}|x_{\mathcal{T}}, x_{\bar{\mathcal{Q}} \setminus \mathcal{Q}}) W(y|\tilde{x}_{\mathcal{T}}, \tilde{x}_{\bar{\mathcal{Q}} \setminus \bar{\mathcal{Q}}}, x'_{\mathcal{H}}, \tilde{x}_{\bar{\mathcal{Q}}}).$$

By (155) and (156),

$$\begin{aligned}
& \sum_{x_{\mathcal{T}}, x_{\bar{\mathcal{Q}} \setminus \mathcal{Q}}, x'_{\mathcal{H}}, \tilde{x}_{\mathcal{T}}, \tilde{x}_{\bar{\mathcal{Q}} \setminus \bar{\mathcal{Q}}}, y} \left(\prod_{i \in \mathcal{T}} P_i(x_i) \right) \left(\prod_{j \in \bar{\mathcal{Q}} \setminus \mathcal{Q}} P_j(x_j) \right) \left(\prod_{l \in \mathcal{H}} P_l(x'_l) \right) \left(\prod_{i \in \mathcal{T}} P_l(\tilde{x}_l) \right) \left(\prod_{j \in \mathcal{Q} \setminus \bar{\mathcal{Q}}} P_j(\tilde{x}_j) \right) \\
& \left| V_{Y|X_{\mathcal{T}} X_{\bar{\mathcal{Q}} \setminus \mathcal{Q}} X'_{\mathcal{H}} \tilde{X}_{\mathcal{T}} \tilde{X}_{\bar{\mathcal{Q}} \setminus \bar{\mathcal{Q}}}}(y|x_{\mathcal{T}}, x_{\bar{\mathcal{Q}} \setminus \mathcal{Q}}, x'_{\mathcal{H}}, \tilde{x}_{\mathcal{T}}, \tilde{x}_{\bar{\mathcal{Q}} \setminus \bar{\mathcal{Q}}}) - V'_{Y|X_{\mathcal{T}} X_{\bar{\mathcal{Q}} \setminus \mathcal{Q}} X'_{\mathcal{H}} \tilde{X}_{\mathcal{T}} \tilde{X}_{\bar{\mathcal{Q}} \setminus \bar{\mathcal{Q}}}}(y|x_{\mathcal{T}}, x_{\bar{\mathcal{Q}} \setminus \mathcal{Q}}, x'_{\mathcal{H}}, \tilde{x}_{\mathcal{T}}, \tilde{x}_{\bar{\mathcal{Q}} \setminus \bar{\mathcal{Q}}}) \right| \leq 2c\sqrt{3\eta}.
\end{aligned}$$

This implies that for $\alpha := \min_{i \in [1:k]} \min_{x_i} P_i(x_i)$ (note that $\alpha > 0$),

$$\begin{aligned}
& \max_{x_{\mathcal{T}}, x_{\bar{\mathcal{Q}} \setminus \mathcal{Q}}, x'_{\mathcal{H}}, \tilde{x}_{\mathcal{T}}, \tilde{x}_{\bar{\mathcal{Q}} \setminus \bar{\mathcal{Q}}}, y} \left| V_{Y|X_{\mathcal{T}} X_{\bar{\mathcal{Q}} \setminus \mathcal{Q}} X'_{\mathcal{H}} \tilde{X}_{\mathcal{T}} \tilde{X}_{\bar{\mathcal{Q}} \setminus \bar{\mathcal{Q}}}}(y|x_{\mathcal{T}}, x_{\bar{\mathcal{Q}} \setminus \mathcal{Q}}, x'_{\mathcal{H}}, \tilde{x}_{\mathcal{T}}, \tilde{x}_{\bar{\mathcal{Q}} \setminus \bar{\mathcal{Q}}}) \right. \\
& \quad \left. - V'_{Y|X_{\mathcal{T}} X_{\bar{\mathcal{Q}} \setminus \mathcal{Q}} X'_{\mathcal{H}} \tilde{X}_{\mathcal{T}} \tilde{X}_{\bar{\mathcal{Q}} \setminus \bar{\mathcal{Q}}}}(y|x_{\mathcal{T}}, x_{\bar{\mathcal{Q}} \setminus \mathcal{Q}}, x'_{\mathcal{H}}, \tilde{x}_{\mathcal{T}}, \tilde{x}_{\bar{\mathcal{Q}} \setminus \bar{\mathcal{Q}}}) \right| \leq \frac{2c\sqrt{3\eta}}{\alpha^j} \tag{157}
\end{aligned}$$

for some integer j . Since (W, \mathcal{A}) is not symmetrizable, there exist $\zeta > 0$ such that

$$\begin{aligned}
& \max_{x_{\mathcal{T}}, x_{\bar{\mathcal{Q}} \setminus \mathcal{Q}}, x'_{\mathcal{H}}, \tilde{x}_{\mathcal{T}}, \tilde{x}_{\bar{\mathcal{Q}} \setminus \bar{\mathcal{Q}}}, y} \left| \sum_{x_{\mathcal{Q}}} P_{X_{\mathcal{Q}}|\tilde{X}_{\mathcal{T}} \tilde{X}_{\bar{\mathcal{Q}} \setminus \bar{\mathcal{Q}}}}(x_{\mathcal{Q}}|\tilde{x}_{\mathcal{T}}, \tilde{x}_{\bar{\mathcal{Q}} \setminus \bar{\mathcal{Q}}}) W(y|x_{\mathcal{T}}, x_{\bar{\mathcal{Q}} \setminus \mathcal{Q}}, x'_{\mathcal{H}}, x_{\mathcal{Q}}) \right. \\
& \quad \left. - \sum_{\tilde{x}_{\bar{\mathcal{Q}}}} P_{\tilde{X}_{\bar{\mathcal{Q}}}|X_{\mathcal{T}} X_{\bar{\mathcal{Q}} \setminus \mathcal{Q}}}(\tilde{x}_{\bar{\mathcal{Q}}}|x_{\mathcal{T}}, x_{\bar{\mathcal{Q}} \setminus \mathcal{Q}}) W(y|\tilde{x}_{\mathcal{T}}, \tilde{x}_{\bar{\mathcal{Q}} \setminus \bar{\mathcal{Q}}}, x'_{\mathcal{H}}, \tilde{x}_{\bar{\mathcal{Q}}}) \right| > \zeta.
\end{aligned}$$

That is

$$\begin{aligned}
& \max_{x_{\mathcal{T}}, x_{\bar{\mathcal{Q}} \setminus \mathcal{Q}}, x'_{\mathcal{H}}, \tilde{x}_{\mathcal{T}}, \tilde{x}_{\bar{\mathcal{Q}} \setminus \bar{\mathcal{Q}}}, y} \left| V_{Y|X_{\mathcal{T}} X_{\bar{\mathcal{Q}} \setminus \mathcal{Q}} X'_{\mathcal{H}} \tilde{X}_{\mathcal{T}} \tilde{X}_{\bar{\mathcal{Q}} \setminus \bar{\mathcal{Q}}}}(y|x_{\mathcal{T}}, x_{\bar{\mathcal{Q}} \setminus \mathcal{Q}}, x'_{\mathcal{H}}, \tilde{x}_{\mathcal{T}}, \tilde{x}_{\bar{\mathcal{Q}} \setminus \bar{\mathcal{Q}}}) \right. \\
& \quad \left. - V'_{Y|X_{\mathcal{T}} X_{\bar{\mathcal{Q}} \setminus \mathcal{Q}} X'_{\mathcal{H}} \tilde{X}_{\mathcal{T}} \tilde{X}_{\bar{\mathcal{Q}} \setminus \bar{\mathcal{Q}}}}(y|x_{\mathcal{T}}, x_{\bar{\mathcal{Q}} \setminus \mathcal{Q}}, x'_{\mathcal{H}}, \tilde{x}_{\mathcal{T}}, \tilde{x}_{\bar{\mathcal{Q}} \setminus \bar{\mathcal{Q}}}) \right| > \zeta.
\end{aligned}$$

This contradicts (157) for choice of η and α satisfying $\frac{2c\sqrt{3\eta}}{\alpha^j} < \zeta$. \square

H Proof of the converse of Theorem 8

Proof. Suppose the given byzantine-MAC (W, \mathcal{A}) is symmetrizable. Then, there exist $\mathcal{T} \subseteq [1 : k]$, $\mathcal{Q}, \mathcal{Q}' \in \mathcal{A}$, not necessarily distinct, satisfying $\mathcal{Q} \cap \mathcal{T} = \mathcal{Q}' \cap \mathcal{T} = \emptyset$, and a pair of conditional distributions $P_{X_{\mathcal{Q}}|X_{\mathcal{T} \cup (\mathcal{Q} \setminus \mathcal{Q}')}}$ and $P'_{X_{\mathcal{Q}'}|X_{\mathcal{T} \cup (\mathcal{Q}' \setminus \mathcal{Q})}}$ satisfying (158) below:

$$\begin{aligned} & \sum_{x'_{\mathcal{Q}} \in \mathcal{X}_{\mathcal{Q}}} P_{X_{\mathcal{Q}}|X_{\mathcal{T} \cup (\mathcal{Q} \setminus \mathcal{Q}')}}(x'_{\mathcal{Q}}|x_{\mathcal{T}}, x_{\mathcal{Q} \setminus \mathcal{Q}'}) W(y|x'_{\mathcal{Q}}, \tilde{x}_{\mathcal{T}}, x_{\mathcal{Q}' \setminus \mathcal{Q}}, x_{(\mathcal{T} \cup \mathcal{Q} \cup \mathcal{Q}')^c}) \\ &= \sum_{\tilde{x}_{\mathcal{Q}'} \in \mathcal{X}_{\mathcal{Q}'}} P'_{X_{\mathcal{Q}'}|X_{\mathcal{T} \cup (\mathcal{Q}' \setminus \mathcal{Q})}}(\tilde{x}_{\mathcal{Q}'}|\tilde{x}_{\mathcal{T}}, x_{\mathcal{Q} \setminus \mathcal{Q}'}) W(y|\tilde{x}_{\mathcal{Q}'}, x_{\mathcal{T}}, x_{\mathcal{Q} \setminus \mathcal{Q}'}, x_{(\mathcal{T} \cup \mathcal{Q} \cup \mathcal{Q}')^c}) \end{aligned} \quad (158)$$

for every $y, x_{\mathcal{T}}, x_{\mathcal{Q} \setminus \mathcal{Q}'}, x_{(\mathcal{T} \cup \mathcal{Q} \cup \mathcal{Q}')^c}, \tilde{x}_{\mathcal{T}}$ and $x_{\mathcal{Q}' \setminus \mathcal{Q}}$. Let $m_{\mathcal{T}}, \tilde{m}_{\mathcal{T}} \in \mathcal{M}_{\mathcal{T}}$ be such that $m_i \neq \tilde{m}_i$ for all $i \in \mathcal{T}$. We consider two different scenarios in which users in set \mathcal{T} send $f_{\mathcal{T}}(m_{\mathcal{T}})$ and $f_{\mathcal{T}}(\tilde{m}_{\mathcal{T}})$ respectively:

- (i) In the first setting, users in the set \mathcal{Q} are adversarial. They choose a message tuple $M_{\mathcal{Q} \setminus \mathcal{Q}'} \sim \text{Unif}(\mathcal{M}_{\mathcal{Q} \setminus \mathcal{Q}'})$. Let $\mathbf{X}_{\mathcal{Q} \setminus \mathcal{Q}'} = f_{\mathcal{Q} \setminus \mathcal{Q}'}(M_{\mathcal{Q} \setminus \mathcal{Q}'})$. To produce their input $\mathbf{X}'_{\mathcal{Q}, m_{\mathcal{T}}}$ to the channel, they pass $(f_{\mathcal{T}}(m_{\mathcal{T}}), \mathbf{X}_{\mathcal{Q} \setminus \mathcal{Q}'})$ through $P_{X_{\mathcal{Q}}|X_{\mathcal{T} \cup (\mathcal{Q} \setminus \mathcal{Q}')}}^n$, the n -fold product of the channel $P_{X_{\mathcal{Q}}|X_{\mathcal{T} \cup (\mathcal{Q} \setminus \mathcal{Q}')}}$. Users in the set $(\mathcal{T} \cup \mathcal{Q})^c$, being non-adversarial, send as their input to the channel $\mathbf{X}_{(\mathcal{T} \cup \mathcal{Q})^c} = f_{(\mathcal{T} \cup \mathcal{Q})^c}(M_{(\mathcal{T} \cup \mathcal{Q})^c})$, where $M_{(\mathcal{T} \cup \mathcal{Q})^c} \sim \text{Unif}(\mathcal{M}_{(\mathcal{T} \cup \mathcal{Q})^c})$. Users in the set \mathcal{T} send $f_{\mathcal{T}}(\tilde{m}_{\mathcal{T}})$. The probability of any vector \mathbf{y} under this scenario is

$$\begin{aligned} & \sum_{\mathbf{x}'_{\mathcal{Q}} \in \mathcal{X}_{\mathcal{Q}}^n} \left(\frac{1}{|\mathcal{M}_{\mathcal{Q} \setminus \mathcal{Q}' }|} \sum_{m_{\mathcal{Q} \setminus \mathcal{Q}' } \in \mathcal{M}_{\mathcal{Q} \setminus \mathcal{Q}' }} P_{X_{\mathcal{Q}}|X_{\mathcal{T} \cup (\mathcal{Q} \setminus \mathcal{Q}')}}^n(\mathbf{x}'_{\mathcal{Q}}|f_{\mathcal{T}}(m_{\mathcal{T}}), f_{\mathcal{Q} \setminus \mathcal{Q}' }(m_{\mathcal{Q} \setminus \mathcal{Q}' })) \right) \\ & \quad \frac{1}{|\mathcal{M}_{(\mathcal{T} \cup \mathcal{Q})^c}|} \sum_{m_{(\mathcal{T} \cup \mathcal{Q})^c} \in \mathcal{M}_{(\mathcal{T} \cup \mathcal{Q})^c}} W^n(\mathbf{y}|\mathbf{x}'_{\mathcal{Q}}, f_{\mathcal{T}}(\tilde{m}_{\mathcal{T}}), f_{(\mathcal{T} \cup \mathcal{Q})^c}(m_{(\mathcal{T} \cup \mathcal{Q})^c})) \\ &= \frac{1}{|\mathcal{M}_{\mathcal{Q} \setminus \mathcal{Q}' }| \times |\mathcal{M}_{(\mathcal{T} \cup \mathcal{Q})^c}|} \sum_{m_{\mathcal{Q} \setminus \mathcal{Q}' } \in \mathcal{M}_{\mathcal{Q} \setminus \mathcal{Q}' }} \sum_{m_{(\mathcal{T} \cup \mathcal{Q})^c} \in \mathcal{M}_{(\mathcal{T} \cup \mathcal{Q})^c}} \prod_{t=1}^n \left(\sum_{\mathbf{x}'_{\mathcal{Q}, t} \in \mathcal{X}_{\mathcal{Q}}} P_{X_{\mathcal{Q}}|X_{\mathcal{T} \cup (\mathcal{Q} \setminus \mathcal{Q}')}}(\mathbf{x}'_{\mathcal{Q}, t}|f_{\mathcal{T}, t}(m_{\mathcal{T}}), f_{\mathcal{Q} \setminus \mathcal{Q}', t}(m_{\mathcal{Q} \setminus \mathcal{Q}'})) \right) \\ & \quad W(\mathbf{y}_t|\mathbf{x}'_{\mathcal{Q}, t}, f_{\mathcal{T}, t}(\tilde{m}_{\mathcal{T}}), f_{(\mathcal{T} \cup \mathcal{Q})^c, t}(m_{(\mathcal{T} \cup \mathcal{Q})^c})) \\ &= \frac{1}{|\mathcal{M}_{(\mathcal{T} \cup (\mathcal{Q} \cap \mathcal{Q}')^c)}|} \sum_{m_{(\mathcal{T} \cup (\mathcal{Q} \cap \mathcal{Q}')^c)} \in \mathcal{M}_{(\mathcal{T} \cup (\mathcal{Q} \cap \mathcal{Q}')^c)}} \prod_{t=1}^n \left(\sum_{\mathbf{x}'_{\mathcal{Q}, t} \in \mathcal{X}_{\mathcal{Q}}} P_{X_{\mathcal{Q}}|X_{\mathcal{T} \cup (\mathcal{Q} \setminus \mathcal{Q}')}}(\mathbf{x}'_{\mathcal{Q}, t}|f_{\mathcal{T}, t}(m_{\mathcal{T}}), f_{\mathcal{Q} \setminus \mathcal{Q}', t}(m_{\mathcal{Q} \setminus \mathcal{Q}'})) \right) \\ & \quad W(\mathbf{y}_t|\mathbf{x}'_{\mathcal{Q}, t}, f_{\mathcal{T}, t}(\tilde{m}_{\mathcal{T}}), f_{(\mathcal{T} \cup \mathcal{Q})^c, t}(m_{(\mathcal{T} \cup \mathcal{Q})^c})) \\ &= \mathbb{E}_{\mathbf{X}'_{\mathcal{Q}, m_{\mathcal{T}}}} [e_{\mathcal{Q}, \mathcal{T}}(\mathbf{y}, \tilde{m}_{\mathcal{T}}, \mathbf{X}'_{\mathcal{Q}, m_{\mathcal{T}}})]. \end{aligned} \quad (159)$$

where $e_{\mathcal{Q}, \mathcal{T}}(\bar{\mathbf{y}}, \tilde{m}_{\mathcal{T}}, \mathbf{x}_{\mathcal{Q}})$ denotes $\frac{1}{|\mathcal{M}_{(\mathcal{T} \cup \mathcal{Q})^c}|} \sum_{m_{(\mathcal{T} \cup \mathcal{Q})^c} \in \mathcal{M}_{(\mathcal{T} \cup \mathcal{Q})^c}} W^n(\bar{\mathbf{y}}|\mathbf{x}_{\mathcal{Q}}, f_{\mathcal{T}}(\tilde{m}_{\mathcal{T}}), f_{(\mathcal{T} \cup \mathcal{Q})^c}(m_{(\mathcal{T} \cup \mathcal{Q})^c}))$ for $\bar{\mathbf{y}}, \tilde{m}_{\mathcal{T}} \in \mathcal{M}_{\mathcal{T}}$ and $\mathbf{x}_{\mathcal{Q}} \in \mathcal{X}_{\mathcal{Q}}^n$. The notation \mathbf{y}_t represents the t^{th} component of the vector \mathbf{y} and for any set \mathcal{S} and message tuple $m_{\mathcal{S}} \in \mathcal{M}_{\mathcal{S}}$, $f_{\mathcal{S}, t}(m_{\mathcal{S}})$ and $\mathbf{x}_{\mathcal{S}, t}$ represents the $|\mathcal{S}|$ -length tuple containing the t^{th} components of the vectors in $f_{\mathcal{S}}(m_{\mathcal{S}})$ and $\mathbf{x}_{\mathcal{S}}$ respectively.

- (ii) In the second setting, users in the set \mathcal{Q}' are adversarial. They choose a message tuple $M_{\mathcal{Q}' \setminus \mathcal{Q}} \sim \text{Unif}(\mathcal{M}_{\mathcal{Q}' \setminus \mathcal{Q}})$. Let $\mathbf{X}_{\mathcal{Q}' \setminus \mathcal{Q}} = f_{\mathcal{Q}' \setminus \mathcal{Q}}(M_{\mathcal{Q}' \setminus \mathcal{Q}})$. To produce their input $\tilde{\mathbf{X}}_{\mathcal{Q}', \tilde{m}_{\mathcal{T}}}$ to the channel, they pass $(f_{\mathcal{T}}(\tilde{m}_{\mathcal{T}}), \mathbf{X}_{\mathcal{Q}' \setminus \mathcal{Q}})$ through $P'_{X_{\mathcal{Q}'}|X_{\mathcal{T} \cup (\mathcal{Q}' \setminus \mathcal{Q})}}^n$, the n -fold product of the channel $P'_{X_{\mathcal{Q}'}|X_{\mathcal{T} \cup (\mathcal{Q}' \setminus \mathcal{Q})}}$. Users in the set $(\mathcal{T} \cup \mathcal{Q}')^c$, being non-adversarial, send $\mathbf{X}_{(\mathcal{T} \cup \mathcal{Q}')^c} = f_{(\mathcal{T} \cup \mathcal{Q}')^c}(M_{(\mathcal{T} \cup \mathcal{Q}')^c})$ as their input to the channel, where $M_{(\mathcal{T} \cup \mathcal{Q}')^c} \sim \text{Unif}(\mathcal{M}_{(\mathcal{T} \cup \mathcal{Q}')^c})$. Users in the set \mathcal{T} send $f_{\mathcal{T}}(m_{\mathcal{T}})$. The probability of any vector \mathbf{y} under this scenario is

$$\sum_{\tilde{\mathbf{x}}_{\mathcal{Q}'} \in \mathcal{X}_{\mathcal{Q}' }^n} \left(\frac{1}{|\mathcal{M}_{\mathcal{Q}' \setminus \mathcal{Q}}|} \sum_{m_{\mathcal{Q}' \setminus \mathcal{Q}} \in \mathcal{M}_{\mathcal{Q}' \setminus \mathcal{Q}}} P'_{X_{\mathcal{Q}'}|X_{\mathcal{T} \cup (\mathcal{Q}' \setminus \mathcal{Q})}}^n(\tilde{\mathbf{x}}_{\mathcal{Q}'}|f_{\mathcal{T}}(\tilde{m}_{\mathcal{T}}), f_{\mathcal{Q}' \setminus \mathcal{Q}}(m_{\mathcal{Q}' \setminus \mathcal{Q}})) \right)$$

$$\begin{aligned}
& \frac{1}{|\mathcal{M}_{(\mathcal{T} \cup \mathcal{Q}')^c}|} \sum_{m_{(\mathcal{T} \cup \mathcal{Q}')^c} \in \mathcal{M}_{(\mathcal{T} \cup \mathcal{Q}')^c}} W^n(\mathbf{y} | \tilde{\mathbf{x}}_{\mathcal{Q}'}, f_{\mathcal{T}}(m_{\mathcal{T}}), f_{(\mathcal{T} \cup \mathcal{Q}')^c}(m_{(\mathcal{T} \cup \mathcal{Q}')^c})) \\
&= \frac{1}{|\mathcal{M}_{\mathcal{Q}' \setminus \mathcal{Q}}| \times |\mathcal{M}_{(\mathcal{T} \cup \mathcal{Q}')^c}|} \sum_{m_{\mathcal{Q}' \setminus \mathcal{Q}} \in \mathcal{M}_{\mathcal{Q}' \setminus \mathcal{Q}}} \sum_{m_{(\mathcal{T} \cup \mathcal{Q}')^c} \in \mathcal{M}_{(\mathcal{T} \cup \mathcal{Q}')^c}} \prod_{t=1}^n \sum_{\tilde{x}_{\mathcal{Q}',t} \in \mathcal{X}_{\mathcal{Q}'}} P'_{X_{\mathcal{Q}'|X_{\mathcal{T} \cup (\mathcal{Q}' \setminus \mathcal{Q})}}(\tilde{x}_{\mathcal{Q}',t} | f_{\mathcal{T},t}(\tilde{m}_{\mathcal{T}}), f_{\mathcal{Q}' \setminus \mathcal{Q},t}(m_{\mathcal{Q}' \setminus \mathcal{Q}}))} \\
& \quad W(\mathbf{y}_t | \tilde{x}_{\mathcal{Q}',t}, f_{\mathcal{T},t}(m_{\mathcal{T}}), f_{(\mathcal{T} \cup \mathcal{Q}')^c,t}(m_{(\mathcal{T} \cup \mathcal{Q}')^c})) \\
&= \frac{1}{|\mathcal{M}_{(\mathcal{T} \cup (\mathcal{Q} \cap \mathcal{Q}'))^c}|} \sum_{m_{(\mathcal{T} \cup (\mathcal{Q} \cap \mathcal{Q}'))^c} \in \mathcal{M}_{(\mathcal{T} \cup (\mathcal{Q} \cap \mathcal{Q}'))^c}} \prod_{t=1}^n \sum_{\tilde{x}_{\mathcal{Q}',t} \in \mathcal{X}_{\mathcal{Q}'}} P'_{X_{\mathcal{Q}'|X_{\mathcal{T} \cup (\mathcal{Q}' \setminus \mathcal{Q})}}(\tilde{x}_{\mathcal{Q}',t} | f_{\mathcal{T},t}(\tilde{m}_{\mathcal{T}}), f_{\mathcal{Q}' \setminus \mathcal{Q},t}(m_{\mathcal{Q}' \setminus \mathcal{Q}}))} \\
& \quad W(\mathbf{y}_t | \tilde{x}_{\mathcal{Q}',t}, f_{\mathcal{T},t}(m_{\mathcal{T}}), f_{(\mathcal{T} \cup \mathcal{Q}')^c,t}(m_{(\mathcal{T} \cup \mathcal{Q}')^c})) \\
&= \mathbb{E}_{\tilde{\mathbf{X}}_{\mathcal{Q}', \tilde{m}_{\mathcal{T}}}} [e_{\mathcal{Q}', \mathcal{T}}(\mathbf{y}, m_{\mathcal{T}}, \tilde{\mathbf{X}}_{\mathcal{Q}', \tilde{m}_{\mathcal{T}}})] \tag{160}
\end{aligned}$$

where $e_{\mathcal{Q}', \mathcal{T}}(\tilde{\mathbf{y}}, \tilde{m}_{\mathcal{T}}, \mathbf{x}_{\mathcal{Q}'})$ denotes $\frac{1}{|\mathcal{M}_{(\mathcal{T} \cup \mathcal{Q}')^c}|} \sum_{m_{(\mathcal{T} \cup \mathcal{Q}')^c} \in \mathcal{M}_{(\mathcal{T} \cup \mathcal{Q}')^c}} W^n(\tilde{\mathbf{y}} | \mathbf{x}_{\mathcal{Q}'}, f_{\mathcal{T}}(\tilde{m}_{\mathcal{T}}), f_{(\mathcal{T} \cup \mathcal{Q}')^c}(m_{(\mathcal{T} \cup \mathcal{Q}')^c}))$ for $\tilde{\mathbf{y}} \in \mathcal{Y}^n$, $\tilde{m}_{\mathcal{T}} \in \mathcal{M}_{\mathcal{T}}$ and $\mathbf{x}_{\mathcal{Q}'} \in \mathcal{X}_{\mathcal{Q}'}$.

Note that

$$\begin{aligned}
& \mathbb{E}_{\tilde{\mathbf{X}}_{\mathcal{Q}', \tilde{m}_{\mathcal{T}}}} [e_{\mathcal{Q}', \mathcal{T}}(\mathbf{y}, m_{\mathcal{T}}, \tilde{\mathbf{X}}_{\mathcal{Q}', \tilde{m}_{\mathcal{T}}})] \tag{161} \\
&= \frac{1}{|\mathcal{M}_{(\mathcal{T} \cup (\mathcal{Q} \cap \mathcal{Q}'))^c}|} \sum_{m_{(\mathcal{T} \cup (\mathcal{Q} \cap \mathcal{Q}'))^c} \in \mathcal{M}_{(\mathcal{T} \cup (\mathcal{Q} \cap \mathcal{Q}'))^c}} \prod_{t=1}^n \sum_{\tilde{x}_{\mathcal{Q}',t} \in \mathcal{X}_{\mathcal{Q}'}} P'_{X_{\mathcal{Q}'|X_{\mathcal{T} \cup (\mathcal{Q}' \setminus \mathcal{Q})}}(\tilde{x}_{\mathcal{Q}',t} | f_{\mathcal{T},t}(\tilde{m}_{\mathcal{T}}), f_{\mathcal{Q}' \setminus \mathcal{Q},t}(m_{\mathcal{Q}' \setminus \mathcal{Q}}))} \\
& \quad W^n(\mathbf{y}_t | \tilde{x}_{\mathcal{Q}',t}, f_{\mathcal{T},t}(m_{\mathcal{T}}), f_{(\mathcal{T} \cup \mathcal{Q}')^c,t}(m_{(\mathcal{T} \cup \mathcal{Q}')^c})) \\
&\stackrel{(a)}{=} \frac{1}{|\mathcal{M}_{(\mathcal{T} \cup (\mathcal{Q} \cap \mathcal{Q}'))^c}|} \sum_{m_{(\mathcal{T} \cup (\mathcal{Q} \cap \mathcal{Q}'))^c} \in \mathcal{M}_{(\mathcal{T} \cup (\mathcal{Q} \cap \mathcal{Q}'))^c}} \prod_{t=1}^n \sum_{x'_{\mathcal{Q},t} \in \mathcal{X}_{\mathcal{Q}}} P_{X_{\mathcal{Q}}|X_{\mathcal{T} \cup (\mathcal{Q} \setminus \mathcal{Q}')}}(x'_{\mathcal{Q},t} | f_{\mathcal{T},t}(m_{\mathcal{T}}), f_{\mathcal{Q} \setminus \mathcal{Q},t}(m_{\mathcal{Q} \setminus \mathcal{Q}})) \\
& \quad W^n(\mathbf{y}_t | x'_{\mathcal{Q},t}, f_{\mathcal{T},t}(\tilde{m}_{\mathcal{T}}), f_{(\mathcal{T} \cup \mathcal{Q})^c,t}(m_{(\mathcal{T} \cup \mathcal{Q})^c})) \\
&= \mathbb{E}_{\mathbf{X}'_{\mathcal{Q}, m_{\mathcal{T}}}} [e_{\mathcal{Q}, \mathcal{T}}(\mathbf{y}, \tilde{m}_{\mathcal{T}}, \mathbf{X}'_{\mathcal{Q}, m_{\mathcal{T}}})] \tag{162}
\end{aligned}$$

where (a) follows from (158).

Arguing along the lines of [22, (3.29) in page 187],

$$2P_e \geq \frac{1}{|\mathcal{M}_{\mathcal{T}}|} \sum_{\tilde{m}_{\mathcal{T}}} \sum_{\mathbf{y}: \phi(\mathbf{y})_{\mathcal{T}} \neq \tilde{m}_{\mathcal{T}}} \mathbb{E}_{\mathbf{X}'_{\mathcal{Q}}} [e_{\mathcal{Q}, \mathcal{T}}(\mathbf{y}, \tilde{m}_{\mathcal{T}}, \mathbf{X}'_{\mathcal{Q}})] + \frac{1}{|\mathcal{M}_{\mathcal{T}}|} \sum_{m_{\mathcal{T}}} \sum_{\mathbf{y}: \phi(\mathbf{y})_{\mathcal{T}} \neq m_{\mathcal{T}}} \mathbb{E}_{\tilde{\mathbf{X}}_{\mathcal{Q}'}} [e_{\mathcal{Q}', \mathcal{T}}(\mathbf{y}, m_{\mathcal{T}}, \tilde{\mathbf{X}}_{\mathcal{Q}'})]$$

for any attack vectors $\mathbf{X}'_{\mathcal{Q}}$ and $\tilde{\mathbf{X}}_{\mathcal{Q}'}$. In particular, for the attack vectors $\frac{1}{|\mathcal{M}_{\mathcal{T}}|} \sum_{\tilde{m}_{\mathcal{T}}} \tilde{\mathbf{X}}_{\mathcal{Q}', \tilde{m}_{\mathcal{T}}}$ and $\frac{1}{|\mathcal{M}_{\mathcal{T}}|} \sum_{m_{\mathcal{T}}} \mathbf{X}'_{\mathcal{Q}, m_{\mathcal{T}}}$,

$$\begin{aligned}
2P_e &\geq \frac{1}{|\mathcal{M}_{\mathcal{T}}|^2} \sum_{\tilde{m}_{\mathcal{T}}} \sum_{m_{\mathcal{T}}} \left(\sum_{\mathbf{y}: \phi(\mathbf{y})_{\mathcal{T}} \neq \tilde{m}_{\mathcal{T}}} \mathbb{E}_{\mathbf{X}'_{\mathcal{Q}}} [e_{\mathcal{Q}, \mathcal{T}}(\mathbf{y}, \tilde{m}_{\mathcal{T}}, \mathbf{X}'_{\mathcal{Q}, m_{\mathcal{T}}})] + \sum_{\mathbf{y}: \phi(\mathbf{y})_{\mathcal{T}} \neq m_{\mathcal{T}}} \mathbb{E}_{\tilde{\mathbf{X}}_{\mathcal{Q}'}} [e_{\mathcal{Q}', \mathcal{T}}(\mathbf{y}, m_{\mathcal{T}}, \tilde{\mathbf{X}}_{\mathcal{Q}', \tilde{m}_{\mathcal{T}}})] \right) \\
&\stackrel{(a)}{=} \frac{1}{|\mathcal{M}_{\mathcal{T}}|^2} \sum_{\tilde{m}_{\mathcal{T}}} \sum_{m_{\mathcal{T}}} \left(\sum_{\mathbf{y}: \phi(\mathbf{y})_{\mathcal{T}} \neq \tilde{m}_{\mathcal{T}}} \mathbb{E}_{\mathbf{X}'_{\mathcal{Q}}} [e_{\mathcal{Q}, \mathcal{T}}(\mathbf{y}, \tilde{m}_{\mathcal{T}}, \mathbf{X}'_{\mathcal{Q}, m_{\mathcal{T}}})] + \sum_{\mathbf{y}: \phi(\mathbf{y})_{\mathcal{T}} \neq m_{\mathcal{T}}} \mathbb{E}_{\mathbf{X}'_{\mathcal{Q}}} [e_{\mathcal{Q}, \mathcal{T}}(\mathbf{y}, \tilde{m}_{\mathcal{T}}, \mathbf{X}'_{\mathcal{Q}, m_{\mathcal{T}}})] \right)
\end{aligned}$$

where (a) follows from (162). For $m_{\mathcal{T}} \neq \tilde{m}_{\mathcal{T}}$, the term in brackets on the right is upper bounded by 1, otherwise it is upper bounded by zero. Thus,

$$P_e \geq \frac{|\mathcal{M}_{\mathcal{T}}|(|\mathcal{M}_{\mathcal{T}}| - 1)/2}{2|\mathcal{M}_{\mathcal{T}}|^2} \geq \frac{1}{8}.$$

This completes the proof of the converse. \square