

# Optimal SMC for Transactional Programs

PAROSH AZIZ ABDULLA, Uppsala University, Sweden

MOHAMED FAOUZI ATIG, Uppsala University, Sweden

ASHUTOSH GUPTA, IIT Bombay, India

SHANKARANARAYANAN KRISHNA, IIT Bombay, India

OMKAR TUPPE, IIT Bombay, India

The verification of transactional concurrent programs running over causally consistent databases is a challenging problem. We present a framework for efficient stateless model checking (SMC) of concurrent programs with transactions under two well known models of causal consistency, CCv and CC. Our approach is based on exploring the program order *po* and the reads from *rf* relations, avoiding exploration of all possible coherence orders. Our SMC algorithm is provably optimal in the sense that it explores each *po* and *rf* relation exactly once. We have implemented our framework in a tool called TRANCHECKER. Experiments show that TRANCHECKER performs well in detecting anomalies in classical distributed databases benchmarks.

Additional Key Words and Phrases: causal consistency, stateless model checking, transactions

## 1 INTRODUCTION

Transactions are a proven abstraction mechanism in database systems for constructing reusable parallel computations. A transactional program is a concurrent program, which has *transactions* in the code of its processes. Transactional programming [Harris et al. 2010] attempts to adapt the powerful transaction processing technology originally developed for database concurrency, to the setting of general purpose concurrent programs. Using transactions as the main enabling construct for shared memory concurrency obviates the programmer from using low level mechanisms like locks, mutexes and semaphores to prevent two concurrent threads from interfering.

A *transaction* is a code segment consisting of several instructions which must be executed *atomically*. Each process in a transactional program is a sequence of transactions, written as  $t_1[\dots]; t_2[\dots]; \dots; t_n[\dots]$ , where  $t[\dots]$  represents a transaction, with the brackets [ and ] demarcating the beginning and end. The general idea is that each process  $p$  executes its transactions following the program order, and, when a process  $p$  finishes executing a transaction  $t[\dots]$ , it “delivers” the writes/data updates made in  $t[\dots]$  to all processes. The manner in which the receiving processes make use of this delivery is dependent on the underlying consistency model of transactional programs.

The strongest consistency model is the one ensuring serializability [Papadimitriou 1979], where every execution of a program is equivalent to another one where the transactions are executed serially one after the other, with no interference. In the non-transactional setting, this model corresponds to sequential consistency (SC) [Lamport 1979]. While serializability and SC are easy to

---

Authors' addresses: Parosh Aziz Abdulla, Uppsala University, Sweden, [parosh@it.uu.se](mailto:parosh@it.uu.se); Mohamed Faouzi Atig, Uppsala University, Sweden, [mohamed\\_faouzi.atig@it.uu.se](mailto:mohamed_faouzi.atig@it.uu.se); Ashutosh Gupta, IIT Bombay, India, [akg@cse.iitb.ac.in](mailto:akg@cse.iitb.ac.in); Shankaranarayanan Krishna, IIT Bombay, India, [krishnas@cse.iitb.ac.in](mailto:krishnas@cse.iitb.ac.in); Omkar Tuppe, IIT Bombay, India, [omkarvtuppe@cse.iitb.ac.in](mailto:omkarvtuppe@cse.iitb.ac.in).

---

Permission to make digital or hard copies of all or part of this work for personal or classroom use is granted without fee provided that copies are not made or distributed for profit or commercial advantage and that copies bear this notice and the full citation on the first page. Copyrights for components of this work owned by others than ACM must be honored. Abstracting with credit is permitted. To copy otherwise, or republish, to post on servers or to redistribute to lists, requires prior specific permission and/or a fee. Request permissions from [permissions@acm.org](mailto:permissions@acm.org).

© 2018 Association for Computing Machinery.

2475-1421/2018/1-ART1 \$15.00

<https://doi.org/>

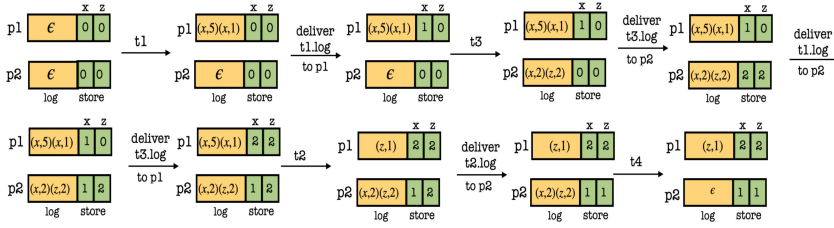

Fig. 2. A CM-consistent execution for the program in Figure 1. A configuration consists of the transaction log as well as the local store per process. The transitions depict how a configuration changes when a transaction is executed in a process, or when a process receives the delivery of the transaction log from another process.

understand for programmers, they are too strong, since they need global synchronization between all processes, which makes it difficult to achieve good performance guarantees [Fischer et al. 1985; Gilbert and Lynch 2002]. Thus, modern databases ensure weaker consistency guarantees.

Causal consistency [Lamport 1978], is a fundamental model implemented in many leading production databases such as AntidoteDB, CockroachDB and MongoDB. Unlike serializability, causal consistency allows conflicting transactions having reads/writes to a common location to be executed in different orders by different processes as long as they are not causally related. The sets of updates visible to different processes may differ and read actions may return values that cannot be obtained in SC executions. There are at least three variations of causal consistency introduced in the literature, weak causal consistency (CC) [Bouajjani et al. 2017; Perrin et al. 2016], causal memory (CM) [Ahmad et al. 1995; Perrin et al. 2016], and causal convergence (CCv) [Burckhardt 2014]. When one considers transactions to be single instructions, CCv is equivalent to SRA (strong release acquire), while CC is equivalent to WRA (weak release acquire) [Lahav 2019].

**Causal Consistency.** We provide a gentle introduction to the 3 models here, via the program in Figure 1. Two key notions needed across the models are that of *causal delivery* and *transaction isolation*. First, a *transaction log* is a sequence of all writes made in order, in a transaction. The log is reset before a transaction begins, and every write  $x := v$  in the transaction appends  $(x, v)$  to the log. Thus, the log of  $t3$  in Figure 1 is  $(x, 2)(z, 2)$ . In causal delivery, if the log of a transaction  $t$  is received by a process before it starts executing a transaction  $t'$ , then the log of  $t$  is received by all processes before receiving the log of  $t'$ . Also, if  $t, t'$  are two transactions in program order in a process  $p$ , with  $t'$  coming later than  $t$ , then the log of  $t$  is always (self)delivered to  $p$

Fig. 1. // are assertions to be checked, based on values read.

before the execution of  $t'$ . Transaction isolation says that while a process is executing a transaction, it will not receive any delivery. Thus, deliveries are received only when a process has finished executing a transaction and not started executing the next transaction. An execution under any of the 3 models respect causal delivery and transaction isolation.

Each process has a *local store*, keeping track of the latest values delivered to it, per variable. Under CM, whenever a process receives a delivery, it updates its local store using the most recent values per variable from the log received. When executing a read  $r = x$  in transaction  $t$ , the process first checks if a write to  $x$  was made already in  $t$ , and if so, reads the latest value written to  $x$  in  $t$ , and if not, takes the value of  $x$  from the local store. The program in Figure 1 has a CM consistent execution as seen in Figure 2.

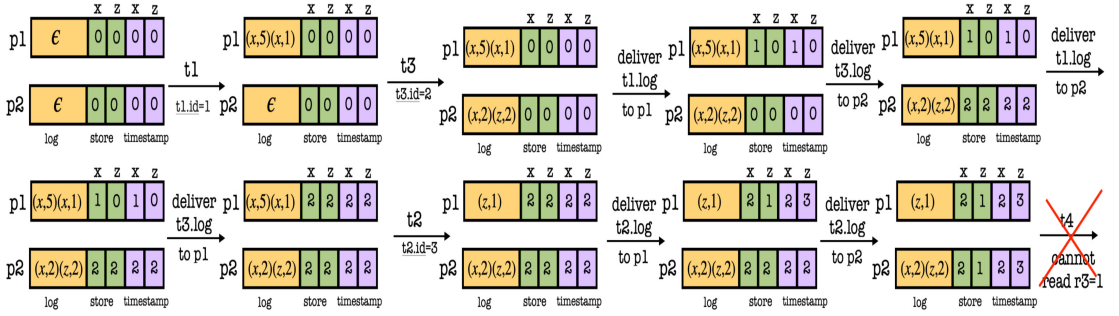

Fig. 3. The program in Figure 1 does not have a CCv consistent execution. A process configuration consists of the transaction log, the local store, as well as the time stamps of variables. As in Figure 2, we depict transitions between configurations.

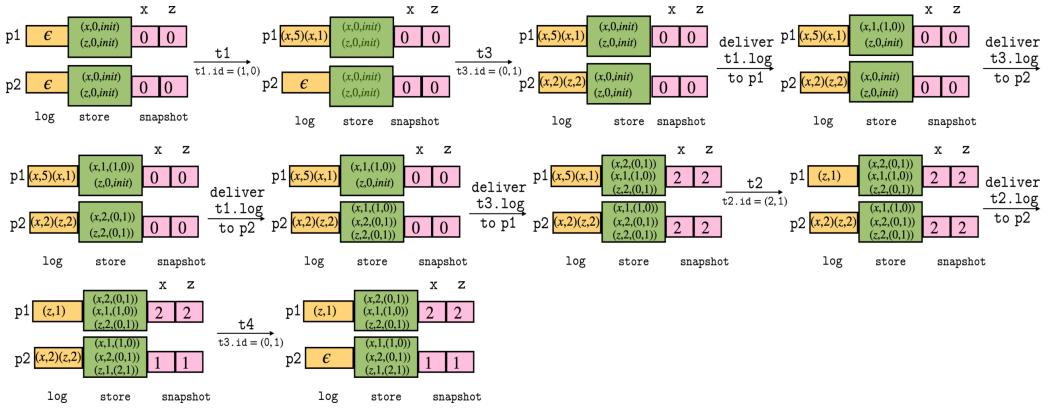

Fig. 4. A CC consistent execution for the program in Figure 1. A process configuration consists of the transaction log, the local store as well as a snapshot of its local store. As for CM, CCv, we depict transitions between configurations.

$t1$  is executed first, then the log  $(x, 5)(x, 1)$  of  $t1$  is delivered to  $p1$ , resulting in  $x \mapsto 1, z \mapsto 0$  as  $p1$ 's local store. Then  $t3$  is executed in  $p2$ , and the log  $(x, 2)(z, 2)$  is delivered to  $p2$ , resulting in  $x \mapsto 2, z \mapsto 2$  as  $p2$ 's local store. Next, we deliver  $t1$ 's log to  $p2$ . On receiving the delivery,  $p2$ 's local store becomes  $x \mapsto 1, z \mapsto 2$ . Next, deliver the log of  $t3$  to  $p1$ . On receiving the log of  $t3$ ,  $p1$ 's local store becomes  $x \mapsto 2, z \mapsto 2$ , and hence  $r1$  can read 2. Next, we deliver  $t2$ 's log to  $p2$ . On receiving the delivery,  $p2$ 's local store becomes  $x \mapsto 1, z \mapsto 1$ , and hence  $r2, r3$  can read 1, 1 respectively.

In CCv, transactions are totally ordered by unique ids ( $\in \mathbb{N}$ ) associated to transactions. Transactions in program order of a process have monotonically increasing ids. Each process  $p$  maintains per variable  $x$ , the timestamp of  $x$ ,  $ts(x)$  which is the largest transaction id among all transaction logs containing an  $(x, v)$ , delivered to  $p$ . On receiving the delivery of a log from a transaction  $t$ , the value of  $x$  in the local store of process  $p$  is updated with the latest value of  $x$  in the log only if  $ts(x)$  in  $p$  is smaller than  $t.id$ . In this case,  $ts(x)$  is also updated to  $t.id$ . The program in Figure 1 cannot have a CCv consistent execution : we need to deliver the log of  $t1$  to  $p2$  after  $t3$  has been executed so that the value of  $x$  read by  $r3$  can be 1. Likewise the log of  $t3$  must be delivered to  $p1$  after  $t1$  is

executed, so that  $r1$  can read value 2. Both of these must take effect to satisfy the assertion. Clearly with time stamps in place, this cannot happen : either  $t1.id > t3.id$  or  $t3.id > t1.id$ . If  $t1.id > t3.id$ , then the delivery of the log of  $t1$  to  $p2$  after executing  $t3$  is useless; likewise if we had  $t3.id > t1.id$ , then delivering the log of  $t3$  to  $p1$  after execution of  $t1$  is useless. Figure 3 depicts this.

In CC, transaction ids are vector clocks. The local store of each process is a set of triples of the form  $(x, v, t.id)$ , where  $t.id$  is the transaction id of the transaction which wrote  $v$  to  $x$ . For each process  $p$ , on receiving delivery of a log from a transaction  $t$ , (1)  $(x, v, t.id)$  is added to the local store of  $p$  if  $t.id$  is incomparable with all the transaction ids of existing triples in the store of  $p$ , (2)  $(x, v, t.id)$  replaces all  $(x, v', t'.id)$  triples in the store of  $p$  if  $t.id > t'.id$ , and (3)  $(x, v)$  is the latest write to  $x$  in the log of  $t$ . Each time a new transaction begins execution in a process  $p$ , it maintains a “snapshot” of its local store, which assigns to each variable, the latest value obtained, from considering a possible linearization of the store. A read instruction  $r = x$  in a transaction  $t$  first checks its log for an  $(x, v)$ . If that is unavailable ( $t$  has not written to  $x$ ),  $r$  reads  $snapshot(x)$ . The program in Figure 1 has a CC consistent execution as seen below.

Choose incomparable vector clocks for  $t1, t3$ , say  $(1,0)$  and  $(0,1)$ . Deliver the log of  $t1$  to  $p2$  after  $t3$  is executed, and the log of  $t3$  to  $p1$  after  $t1$  is executed. The local store of  $p2, p1$  will then be  $\{(x, 2, t3.id), (z, 2, t3.id), (x, 1, t1.id)\}$ .  $p1$  can choose  $snapshot(x) = 2$  since  $t1, t3$  is a linearization of the store, enabling the read of 2 in  $r1$ . Next, choose  $t2.id$  as  $(2,1)$ , and execute  $t2$ . Deliver the log of  $t2$  to  $p2$ . Then  $(z, 1, t2.id)$  is added to the local store of  $p2$ .  $p2$  can choose  $snapshot(x) = 1, snapshot(z) = 1$  since  $t3, t1, t2$  is a linearization of the store. This enables  $r2, r3 = 1$ .

## 2 RELATED WORK AND CONTRIBUTIONS

The main contribution of this paper is a Stateless Model Checking (SMC) algorithm for transactional programs under causal consistency.

### 2.1 Related Work

We compare our contribution with two lines of work. On one hand, we review work on the verification of causal consistency models, and on the other hand, on SMC algorithms.

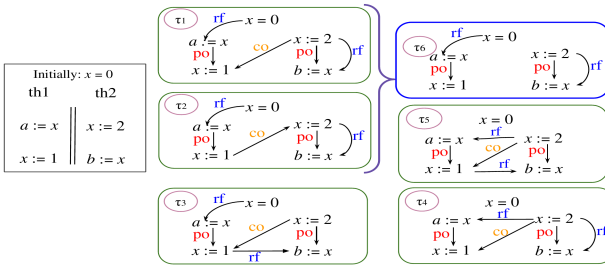

Fig. 5. A non-transactional program and its Shasha-Snir traces.

There has been a spate of recent work on causal consistency models [Ahmad et al. 1995]. The question of verifying automatically, whether a given transactional program is robust against causal consistency has been explored in many papers, [Bernardi and Gotsman 2016], [Brutschy et al. 2017], [Brutschy et al. 2018], [Cerone and Gotsman 2018], [Nagar and Jagannathan 2018] via under and over approximation techniques. Checking robustness amounts to asking whether the behaviours obtained while execut-

ing over a causally consistent database are serializable. The latest in this direction providing a precise robustness algorithm is [Beillahi et al. 2021b], which showed that verifying robustness against causal consistency reduces to the reachability problem under SC. As a means to analyse the robustness problem for CC, [Cerone et al. 2017] provide an algebraic connection between the operational and axiomatic semantics of CC. In the non-transactional setting, [Lahav 2019] surveys

WRA (analogue of CC), SRA (analogue of CCv) and discusses the operational and axiomatic semantics of both models. [Raad et al. 2019] proposes a lock-based reference implementation for *snapshot isolation* (SI), a weak consistency model used in databases such as Oracle and MS SQL server, while prior work [Raad et al. 2018] did the same for *parallel snapshot isolation* (PSI), a model closely related to snapshot isolation. [Xiong et al. 2020] identify a consistency model *weak snapshot isolation* (WSI) that sits in between SI and PSI and propose an operational semantics for client observable behaviours of atomic transactions. [Chong et al. 2018] considers the interplay between weak memory and transactional memory [Herlihy and Moss 1993] by extending existing axiomatic weak memory models (x86, Power, ARMv8, and C++) with new rules for transactional memory. They also synthesize tests for validating these models on existing implementations. Thus, there has been a lot of work on causal consistency models in terms of checking robustness, providing operational/axiomatic semantics as well as exploring the relationship between various models. Given the widespread application of causal consistency models in distributed databases, the verification of these models are of utmost importance.

In contrast to our paper, none of the earlier works provide algorithms that can systematically explore all executions of a concurrent program under causal consistency and certify them safe against concurrency bugs. We close this gap here, by providing a stateless model checking (SMC) algorithm for transactional programs under CCv, CC.

SMC is a successful technique for finding concurrency bugs [Godefroid 1997]. For a terminating program, SMC systematically explores all thread schedulings that are possible during runs of the program. A runtime scheduler drives the SMC exploration by making decisions on scheduling whenever such choices affect interaction between threads. SMC has been implemented in many tools CHESS [Musuvathi et al. 2008], Concuerror [Christakis et al. 2013], VeriSoft [Godefroid 2005], NIDHUGG [Abdulla et al. 2015], CDSChecker [Norris and Demsky 2016], RCMC [Kokologiannakis et al. 2018], GenMC [Kokologiannakis and Vafeiadis 2021], rInspect [Zhang et al. 2015] and Tracer [Abdulla et al. 2018]. The number of possible schedulings grows exponentially with the execution length in SMC. To counter this and reduce the number of explored executions, the technique of *partial order reduction* [Clarke et al. 1999; Godefroid 1996] has been proposed. This has been adapted to SMC as DPOR (dynamic partial order reduction). DPOR was first developed for concurrent programs under SC [Abdulla et al. 2014; Sen and Agha 2006]. Recent years have seen DPOR adapted to language induced weak memory models such as RC11 [Kokologiannakis et al. 2018; Norris and Demsky 2016], the release acquire fragment of C11 [Abdulla et al. 2018], as well as hardware-induced relaxed memory models [Abdulla et al. 2015; Zhang et al. 2015]. DPOR is based on the observation that two executions are equivalent if they induce the same ordering between conflicting events, and hence it is sufficient to consider one such execution from each equivalence class. Under sequential consistency, these equivalence classes are called *Mazurkiewicz* traces [Mazurkiewicz 1987], while for relaxed memory models, the generalization of these are called *Shasha-Snir* traces [Shasha and Snir 1988]. A Shasha-Snir trace characterizes an execution of a concurrent program by three relations between events : (1) *po* program order, totally orders events of each process, (2), *rf* reads from, connects each read with the write it reads from, (3) *co* coherence order, totally orders writes to the same shared variable. Figure 5 gives a program and its Shasha-Snir traces. Note that traces  $\tau_1$  and  $\tau_2$  differ only in *co*. These two traces can be considered equivalent since each process goes through the same local states in both traces : note that the values read by  $a, b$  are the same in both  $\tau_1, \tau_2$ , and to check an assertion on the local variables  $a, b$ , the *co* relation does not matter. An optimal DPOR should only explore  $\tau_6$ , ignoring the *co* relation, rather than exploring both  $\tau_1, \tau_2$ .

In recent years, there has been much interest in DPOR algorithms : [Abdulla et al. 2019] for SC, [Kokologiannakis and Vafeiadis 2021] for the release acquire semantics, [Silva and Leino 2021] for



C/C++, and [Kokologiannakis et al. 2022] for TSO, PSO and RC11. However, none of these work for transactional programs, which is the subject of this paper. As we describe in Section 2.2, extending these to work in the transactional setting has many non trivial tasks to be accomplished.

## 2.2 Challenges and Contributions

We now summarize the main challenges in the development of our DPOR algorithm.

**Axiomatization and equivalence with operational semantics.** The first step to a DPOR for transactional programs is to have an axiomatization of the causal consistency semantics. To this end, we provide a generalization of Shasha-Snir traces to work for transactional programs under causal consistency, by extending the *po*, *rf*, *co* relations to transactions. Then we define the notions of CCv, CC consistent traces. Using this notion of traces, we provide an axiomatic semantics for CCv, CC and prove their equivalence with their known operational semantics [Beillahi et al. 2021b].

**Exploring weak traces.** Building up on the notion of traces, our algorithm focuses only on exploring so called weak traces. For a trace  $\tau$ , dropping the *co* relations gives the corresponding weak trace  $weak(\tau)$  [Abdulla et al. 2018]. Mazurkiewicz traces have the disadvantage of often being too strong. More precisely, they induce an equivalence relation that is unnecessarily fine for checking typical properties such as program errors or assertion violations. The equivalence relation includes coherence order, i.e., the order in which write events on shared variables reach the memory. Coherence order is irrelevant for checking the above properties, and hence using Mazurkiewicz traces is a large source of redundancy, inherently limiting the efficiency that can possibly be achieved in the analysis.

Keeping this in mind, in the non-transactional setting the idea of exploring only weak traces, that is, those in the equivalence classes induced by *po*, *rf* is preferred as a way to obtain optimality on the number of explored traces [Abdulla et al. 2018], [McKinley and Fisher 2019], [Kokologiannakis et al. 2022]. Making this work in the transactional setting is one of the challenges we overcome here. One of the main difficulties while working with weak traces is to determine which continuations of a currently explored trace will allow a coherence order that makes the trace consistent with CCv, CC. Prior work in the non-transactional setting with weak traces proceeded by adding only those *co* edges which are necessary to check if the trace is consistent with the model. The difficulty and complexity of this consistency check differs from one model to another. For instance, it is polynomial for release acquire [Abdulla et al. 2018], while for SC it is NP-complete [Chalupa et al. 2017]. We need to tackle this in the setting of transactional programs.

To solve this question for transactional programs under CCv and CC, we define a notion of *fulfilment*, which decides which *co* edges must be added while extending a trace so that the resultant traces preserve CCv, CC consistency. On adding these necessary *co* edges, the traces become fulfilled traces. During exploration, DPOR algorithm maintains a fulfilled version of the currently explored weak trace, and we precisely examine those weak traces which are CCv, CC consistent. Adding a write event to a fulfilled trace results in a fulfilled trace, while, adding a read event to a fulfilled trace requires care in choosing write events it can read from, so that the resultant trace remains fulfilled after adding the *rf* edge. We identify which transactions can be read from by computing the *readable sets* for each read event. After adding the *rf* edge, some *co* edges are necessary to be added from transactions in the readable set to the remaining transactions, so that the trace remains fulfilled. In contrast to the non-transactional case, it is non-trivial to determine, (i) which transaction can be read from (to add the *rf* edge) and (ii) which *co* edges should be added. We show that computing a CCv, CC consistent successor trace of a given fulfilled trace can be done in polynomial time, making our trace exploration efficient. For CM, this is work in progress.

**A sound, complete and optimal DPOR algorithm for CCv, CC.** We show that our CCv, CC DPOR algorithms are s.t. (i) each CCv, CC consistent weak trace is explored exactly once (optimality), (ii) all the explored traces are CCv, CC consistent (soundness), (iii) if  $\rho$  is a terminating execution corresponding to a total CCv, CC consistent trace  $\tau$ , then the algorithm explores a trace  $\tau'$  such that  $weak(\tau) = weak(\tau')$  (completeness).

**The first SMC tool for CCv, CC.** We have implemented our fulfilled semantics and DPOR in a tool TRANCHECKER, by extending NIDHUGG, an SMC tool for multithreaded C/C++ programs based on LLVM. First, as a sanity check we ran TRANCHECKER on known litmus tests [Alglave et al. 2014] adapting them to the transactional setting (Section 7.1). Then we proceeded with experimental evaluation on a wide range of benchmarks from distributed databases. We showed that (i) TRANCHECKER correctly detects known transaction anomalies [Bernardi and Gotsman 2016], [Biswas and Enea 2019], [Beillahi et al. 2021b] and [Beillahi et al. 2021a] under CCv and CC (Section 7.2), (ii) TRANCHECKER correctly detects known bugs in applications using transactions [Difallah et al. 2013], [Holt et al. 2016], [Beillahi et al. 2021b], [Nair et al. 2020] (Section 7.3). To the best of our knowledge, TRANCHECKER is the first SMC tool for transactional concurrent programs.

### 3 CAUSAL CONSISTENCY

*Program Syntax.* We consider transactional programs  $\mathcal{P}$  consisting of a finite set of *threads* or *processes*  $p \in \mathbb{P}$  that share a finite set of shared variables  $\mathcal{V}$  over a data domain  $\mathcal{D}$ . Each process has a finite set of local registers that store values from  $\mathcal{D}$ . Each process runs a deterministic code, built in a standard way from expressions and atomic commands, using standard control flow constructs (sequential composition, selection, and bounded loop constructs). We use  $x, y$  for shared variables,  $r, r1, r2, r3 \dots$  for local registers and  $e$  for expressions. Expressions are only over local registers.

Each process is a sequence of *transactions* and each transaction is a sequence of *labeled instructions* Lab. Let  $\mathcal{T}$  denote the set of all transactions in  $\mathcal{P}$ . A transaction  $t \in \mathcal{T}$  in process  $p$  starts with a `begin( $p, t$ )` instruction and ends with an `end( $p, t$ )` instruction (in the figures, we simply denote these by opening and closing braces [ and ]). The instructions between the `begin` and `end` instructions can be write/read/assign instructions. Write instructions  $x := e$  write to the shared variable  $x$  while read instructions  $r := x$  read from the shared variables  $x$ . Assignments have the form  $r := e$  involving local registers and expressions. We assume that the control cannot pass from one transaction to another without going through `begin` and `end` instructions.

*Program Semantics.* Each process maintains its own local valuation of the shared variables, called its *local store*. The local store of each process consists of pairs  $(x, v)$  corresponding to each shared variable  $x$ , and its value  $v$ . During the execution of a transaction, writes made to the shared variables are stored in a *transaction log*  $\in (\mathcal{V} \times \mathcal{D})^*$  which is visible only to the process executing the transaction, and is broadcast to all processes at the end of the transaction.

A configuration is defined as the tuple  $\sigma = \langle ls, msgs \rangle$ , where  $ls$  is a mapping from processes  $p \in \mathbb{P}$  to their local states.  $msgs$  is a set of ‘messages in transit’ of the form  $m = (t.id, log)$ , where  $t.id$  is a transaction identifier and  $log \in (\mathcal{V} \times \mathcal{D})^*$ . The local state  $ls(p)$  of a process  $p$  defined as  $ls(p) = (pc, log, store, rval)$  consists of (i) the program counter  $pc \in \text{Lab}$  which gives the label of the next instruction to be executed, (ii)  $log$  is the transaction log which is a sequence of (shared variable,value) pairs, (iii)  $store : \mathcal{V} \rightarrow \mathcal{D}$  is the local store of a process, (iv)  $rval$  is the valuations of local registers. For  $k \in \{pc, log, store, rval\}$ ,  $ls(p).k$  represents the respective component of  $ls(p)$ . A `begin( $p, t$ )` instruction affects only the transaction log of  $p$  by resetting it (makes  $ls(p).log = \epsilon$ ). Each time a write  $x := v$  is performed in the current transaction of  $p$ ,  $(x, v)$  is appended to  $ls(p).log$ . A read from a shared variable  $x$  in a process  $p$  first accesses  $ls(p).log$  and takes the latest written value on  $x$ , if any. In case the current transaction does not have any writes on  $x$ , it takes the value from its local store  $ls(p).store$ . The last instruction in a transaction  $t$  of process  $p$  is `end( $p, t$ )`.

$$\begin{array}{c}
\frac{\text{begin} \in \text{inst}(\text{ls}(p).\text{pc}) \quad \text{ls}(p).\text{ts}(x) < t.\text{id} \quad \forall x \in \mathcal{V} \quad s = \text{ls}(p)[\text{log} \mapsto \epsilon, \text{pc} \mapsto \text{next}(\text{pc})]}{(\text{ls}, \text{msgs}) \xrightarrow{\text{begin}(p, t)} (\text{ls}[p \mapsto s], \text{msgs})} \\
\\
\frac{r := x \in \text{inst}(\text{ls}(p).\text{pc}) \quad \text{eval}(\text{ls}(p), x) = v \quad \text{rval} = \text{ls}(p).\text{rval}[r \mapsto v] \quad s = \text{ls}(p)[\text{rval} \mapsto \text{rval}, \text{pc} \mapsto \text{next}(\text{pc})]}{(\text{ls}, \text{msgs}) \xrightarrow{r(p, t, x, v)} (\text{ls}[p \mapsto s], \text{msgs})} \\
\\
\frac{x := v \in \text{inst}(\text{ls}(p).\text{pc}) \quad \text{log} = (\text{ls}(p).\text{log}) \cdot (x, v) \quad s = \text{ls}(p)[\text{log} \mapsto \text{log}, \text{pc} \mapsto \text{next}(\text{pc})]}{(\text{ls}, \text{msgs}) \xrightarrow{w(p, t, x, v)} (\text{ls}[p \mapsto s], \text{msgs})} \\
\\
\frac{\text{end} \in \text{inst}(\text{ls}(p).\text{pc}) \quad s = \text{ls}(p)[\text{pc} \mapsto \text{next}(\text{pc})]}{(\text{ls}, \text{msgs}) \xrightarrow{\text{end}(p, t)} (\text{ls}[p \mapsto s], \text{msgs} \cup \{(t.\text{id}, \text{ls}(p).\text{log})\})} \\
\\
\frac{\langle t.\text{id}, \text{log} \rangle \in \text{msgs} \quad \text{store} = \text{ls}(p).\text{store}[x \mapsto \text{last}(\text{log}, x) : x \in \mathcal{V}, \text{last}(\text{log}, x) \neq \perp, \text{ts}(x) < t.\text{id}] \quad s = \text{ls}(p)[\text{store} \mapsto \text{store}] \\ \text{ts} = \text{ls}(p).\text{ts}[x \mapsto t.\text{id} : x \in \mathcal{V}, \text{last}(\text{log}, x) \neq \perp, \text{ts}(x) < t.\text{id}]}{(\text{ls}, \text{msgs}) \xrightarrow{\text{del}(p, t)} (\text{ls}[p \mapsto s], \text{msgs})}
\end{array}$$

Fig. 6. The operational semantics for CCv [Beillahi et al. 2021b]. We assume that all the events which come from the same transaction use a unique transaction identifier  $t$ . For a function  $f$ , we use  $f[a \mapsto b]$  to denote a function  $g$  such that  $g(c) = f(c)$  for all  $c \neq a$  and  $g(a) = b$ . The function  $\text{inst}$  returns the set of instructions labeled by some given label while  $\text{next}$  gives the next instruction to execute. We use  $\cdot$  to denote sequence concatenation. The function  $\text{eval}(\text{ls}(p), x)$  returns the value of  $x$  in the local state  $\text{ls}(p)$ : (1) if  $\text{ls}(p).\text{log}$  contains a pair  $(x, v)$ , for some  $v$ , then  $\text{eval}(\text{ls}(p), x)$  returns the value of the last such pair in  $\text{ls}(p).\text{log}$ , and (2)  $\text{eval}(\text{ls}(p), x)$  returns  $\text{ls}(p).\text{store}(x)$ , otherwise. Also,  $\text{last}(\text{log}, x)$  returns the value  $v$  in the last pair  $(x, v)$  in  $\text{log}$ , and  $\perp$ , if such a pair does not exist.

On  $\text{end}(p, t)$ , we add  $(t.\text{id}, \text{ls}(p).\text{log})$  to  $\text{msgs}$ .  $(t.\text{id}, \text{ls}(p).\text{log}) \in \text{msgs}$  is delivered to  $p$  (denoted  $\text{del}(p, t)$ ) before  $p$  chooses the next transaction to execute. Apart from the self delivery of  $t$ , any other message from  $\text{msgs}$  can also be delivered to  $p$  before it begins a fresh transaction. The delivery of  $(t.\text{id}, \text{ls}(p).\text{log}) \in \text{msgs}$  to a process  $p'$  is denoted by the event  $\text{del}(p', t)$ . When a process  $p'$  receives this delivery, the last write on a variable  $x$  from  $\text{ls}(p).\text{log}$  is applied on the local store  $\text{ls}(p').\text{store}$ . Delivery of transaction logs respect causal delivery and transaction isolation, as described below.

*Events.* The operational semantics [Beillahi et al. 2021b] is defined as a labeled transition system over configurations. Each transition corresponds either to a process executing an instruction in its current transaction, or delivering a transaction log. The transition from configuration  $\sigma$  to configuration  $\sigma'$  is symbolized by  $\sigma \xrightarrow{\ell} \sigma'$ .

Here configuration  $\sigma'$  is the successor of configuration  $\sigma$  and  $\ell$  is the label of the transition. The labels come from a set of events  $\{\text{begin}(p, t), \text{end}(p, t), \text{del}(p, t), w(p, t, x, v), r(p, t, x, v)\}$ , where  $p \in \mathcal{P}$ ,  $t \in \mathcal{T}$ ,  $x \in \mathcal{V}$ , and  $v \in \mathcal{D}$ .  $\text{begin}(p, t)$ ,  $\text{end}(p, t)$  represent the begin, end of transaction  $t$  in process  $p$  and  $\text{del}(p, t)$  represents delivery of the transaction log (of transaction  $t$ ), to process  $p$ .  $w(p, t, x, v)$ ,  $r(p, t, x, v)$  respectively represent write and read events of variable  $x$  in transaction  $t$  of process  $p$ , writing or reading value  $v \in \mathcal{D}$ . For an event  $ev$  of the form  $w(p, t, x, v)$  or  $r(p, t, x, v)$  we define by  $ev.\text{var} = x$ ,  $ev.\text{trans} = t$ ,  $ev.\text{type} = W$  or  $ev.\text{type} = R$  and  $ev.\text{process} = p$ . We define a special transaction which has only write events of the form  $\text{init}_x = w(-, -, x, 0)$ , called *initializer*, which initializes all shared variables  $x$  with 0.

*The transition relation.* The labeled transition system (LTS) corresponding to program  $\mathcal{P}$  is defined as  $\text{LTS}[\mathcal{P}] = (\mathcal{G}, \text{Ev}, \mathcal{G}_0, \rightarrow)$  where  $\mathcal{G}$  is the set of configurations,  $\text{Ev}$  is the set of events due to which transitions on configurations occur,  $\mathcal{G}_0$  denotes initial configurations, and  $\rightarrow$  is the transition



relation. In the LTS, each transition  $\rightarrow$  corresponds to a change in configuration after executing an event from  $Ev$ . An *execution*  $\rho$  of a program from a configuration  $\sigma \in \mathcal{G}$  is a transition sequence of configurations where each transition is due to one of the events in  $Ev$ .

The transitions involving  $\text{del}(p, t)$  represent the delivery of the messages in transit. An execution satisfies *transaction isolation* and *causal delivery* as explained below.

- *Transaction isolation*. No deliveries to  $p$  happen when  $p$  is executing a transaction  $t$ ; there are no events  $\text{del}(p, t')$  between  $\text{begin}(p, t)$  and  $\text{end}(p, t)$ .
- An execution  $\rho$  satisfies *causal delivery* if the following hold.
  - (i) corresponding to any  $\text{begin}(p, t)$ ,  $\rho$  contains at most one event  $\text{del}(p', t)$ . That is, each transaction  $t$  which is executed in a process  $p$  is delivered to a process  $p'$  at most once.
  - (ii) For any two events  $\text{begin}(p, t)$  and  $\text{begin}(p, t')$  if  $\text{begin}(p, t)$  occurs in  $\rho$  before  $\text{begin}(p, t')$ , then  $\text{del}(p, t)$  occurs before  $\text{begin}(p, t')$ . Thus,  $p$  stores the writes of  $t$  in  $\text{ls}(p).\text{store}$  before issuing another transaction  $t'$ .
  - (iii) for events  $ev_1 \in \{\text{del}(p, t_1), \text{end}(p, t_1)\}$ ,  $ev_2 = \text{begin}(p, t_2)$ ,  $ev'_2 = \text{del}(p', t_2)$  with  $p \neq p'$ , if  $ev_1$  occurs in execution  $\rho$  before  $ev_2$ , then there exists  $ev'_1 = \text{del}(p', t_1)$  such that  $ev'_1$  occurs before  $ev'_2$  in  $\rho$ . That is, if  $t_1$  is delivered to  $p$  before executing  $t_2$  in  $p$ , or if  $t_1$  finishes in  $p$  before starting  $t_2$ , then for any process  $p' \neq p$ ,  $t_1$  is delivered before  $t_2$ .

Terminal configurations are those from which no transitions are available. An *execution*  $\rho$  of a program starts from an initial configuration  $\sigma_0 \in \mathcal{G}_0$  and is a sequence of transitions,  $\sigma_0 \xrightarrow{\ell_1} \sigma_1 \xrightarrow{\ell_2} \sigma_2 \xrightarrow{\ell_3} \sigma_3 \cdots \xrightarrow{\ell_{n-1}} \sigma_{n-1} \xrightarrow{\ell_n} \sigma_n$ , where  $\sigma_n$  is a terminal configuration, and  $\ell_i \in Ev(\rho)$ , where  $Ev(\rho) = \{\text{begin}(p, t), \text{end}(p, t), \text{del}(p, t), w(p, t, x, v), r(p, t, x, v)\}$  is the set of all events from  $\rho$ . Let  $\mathcal{T}(\rho)$  be the set of all transactions participating in  $\rho$ . Let  $\mathcal{T}(\rho)^{w,x}$  ( $\mathcal{T}(\rho)^{r,x}$ ) be all transactions in  $\mathcal{T}(\rho)$  having a write (read) instruction on variable  $x$ , and let  $\mathcal{T}(\rho)^w = \bigcup_{x \in \mathcal{V}} \mathcal{T}(\rho)^{w,x}$  ( $\mathcal{T}(\rho)^r = \bigcup_{x \in \mathcal{V}} \mathcal{T}(\rho)^{r,x}$ ). Denote by  $\text{ExecFrom}(\sigma)$  all executions starting from configuration  $\sigma$ .

**Causal Memory Semantics(CM)**. The set of executions of  $LTS[\mathcal{P}]$  under causal memory, denoted  $\text{Exec}_{\text{CM}}(\mathcal{P})$  are those executions satisfying transaction isolation and causal delivery.

### 3.1 Causal Convergence Semantics(CCV)

In CCV, each transaction  $t$  in a process is identified by a unique *transaction identifier*  $t.\text{id} \in \mathbb{N}$ , totally ordering all transactions

The transaction identifiers are totally ordered according to some relation  $<$ .

(i) The local state  $\text{ls}(p)$  of a process  $p$  defined as  $\text{ls}(p) = (\text{pc}, \text{log}, \text{store}, \text{rval}, \text{ts})$ , where the first 4 components are as before, and  $\text{ts} \in \mathbb{N}^{|\mathcal{V}|}$  is the tuple of the largest time stamps the process has seen per variable. Initially, we assume  $\text{ls}(p).\text{ts}(x) = 0$  for all variables  $x$  and processes  $p$ .

(ii) A  $\text{begin}(p, t)$  transition will choose a transaction identifier  $t.\text{id} > \text{ls}(p).\text{ts}(x)$  for all  $x \in \mathcal{V}$ .  
 (iii) When a process  $p$  receives the delivery of a *log* corresponding to transaction  $t$ , the last write on a variable  $x$  from *log* is applied on the local store  $\text{ls}(p).\text{store}$  only if  $\text{ls}(p).\text{ts}(x) < t.\text{id}$ , and in this case,  $\text{ls}(p).\text{ts}(x)$  is updated to  $t.\text{id}$ .

**CCV executions**. The set of executions of  $LTS[\mathcal{P}]$  under causal convergence, denoted  $\text{Exec}_{\text{CCV}}(\mathcal{P})$  are those executions satisfying transaction isolation, causal delivery, and which guarantees that each process generates monotonically increasing transaction identifiers. Figure 6 gives the transition rules under CCV.

### 3.2 Weak Causal Consistency Semantics(CC)

In CC, each transaction  $t$  is identified by a unique transaction identifier  $t.\text{id}$  given as a *vector clock* [Lamport 1978], which play the role of timestamps, and are partially ordered according to

some relation  $<$ . Define  $t_1.id < t_2.id$  iff  $t_1$  is delivered to the process of  $t_2$  before  $t_2$  begins.  $t_1, t_2$  are *concurrent* if  $t_1.id$  is incomparable to  $t_2.id$ .

(i)  $\text{store} : \mathcal{V} \rightarrow \mathfrak{p}(\mathcal{D} \times \mathcal{T})$ : the local store of each process  $p$  maintains for each variable  $x$ , a set of pairs, having the value  $v$  written along with the transaction which wrote it. Thus, the local store of  $p$  wrt  $x$  is a set of pairs  $(v, t.id)$ . On applying the log of a transaction  $t$  on the local state of the receiving process  $p$ , for each  $x$ ,  $\text{ls}(p).\text{store}(x)$  is updated to contain  $(v_x, t.id)$ , where  $v_x$  is the most recent value for  $x$  in the log, along with all  $(v, t'.id)$  that were present earlier in it, such that  $t', t$  are concurrent.

(ii) The local state  $\text{ls}(p)$  of a process  $p$  is  $\text{ls}(p) = (\text{pc}, \text{log}, \text{store}, \text{rval}, \text{ts}, \text{snapshot})$  where  $\text{pc}, \text{log}, \text{rval}$  are as before,  $\text{store}$  is as above,  $\text{ts}$  is a vector clock which dominates all the  $t.id$ s from all pairs  $(v, t.id) \in \text{ls}(p).\text{store}(x)$  for all  $x$ . A new transaction  $t$  which begins in a process  $p$  chooses  $t.id > \text{ls}(p).\text{ts}$ . Lastly,  $\text{snapshot} : \mathcal{V} \rightarrow (\mathcal{D} \times \mathcal{T})$  maps each shared variable  $x$  to a single pair  $(v, t.id)$ .  $\text{ls}(p).\text{snapshot}$  is obtained by taking a “consistent” snapshot from  $\text{ls}(p).\text{store}$  when a new transaction begins in  $p$ .  $\text{ls}(p).\text{snapshot}$  corresponds to a linearization of the transactions that were delivered to  $p$ , and consistent with the vector clock order. The snapshot associates to each  $x \in \mathcal{V}$  the last value written in this linearization. When  $p$  does a read from  $x \in \mathcal{V}$ , it looks first at  $\text{ls}(p).\text{log}$  and then, at  $\text{ls}(p).\text{snapshot}(x)$ .

*CC executions.* The set of executions of  $LTS[\mathcal{P}]$  under CC, denoted  $\text{Exec}_{\text{CC}}(\mathcal{P})$  are those executions satisfying transaction isolation and causal delivery, apart from respecting the above mentioned conditions on updating the store and snapshot, which decides which values can be read. The formal operational semantics of CC are available in the appendix.<sup>4</sup>

### An Example to illustrate CCv

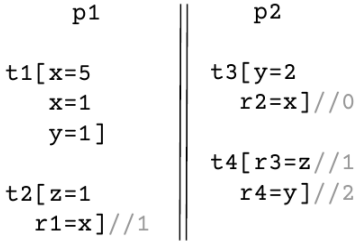

Fig. 7. CCv Example

Consider the program in Figure 7. In the initial configuration  $(\text{ls}, \text{msgs})$ , we have  $\text{ls}(p_1).\text{log}, \text{ls}(p_2).\text{log}$  are both  $\epsilon$ ,  $\text{ls}(p_1).\text{store}, \text{ls}(p_2).\text{store}$  are both  $x \mapsto 0, y \mapsto 0, z \mapsto 0$ , and  $\text{ls}(p_1).\text{rval}, \text{ls}(p_2).\text{rval}$  assign 0 to all local registers. Finally,  $\text{ls}(p_i).\text{ts}(\alpha) = 0$  for both  $i = 1, 2$  and  $\alpha \in \{x, y, z\}$ .  $\text{msgs}$  is empty (and will be populated whenever a transaction ends).

Consider the CCv execution where transaction  $t_1$  is executed choosing  $t_1.id = 1$ . After the first write,  $\text{ls}(p_1).\text{log} = (x, 1)$ , and after the second write,  $\text{ls}(p_1).\text{log} = (x, 1) \cdot (y, 1)$ . At the end of  $t_1$ ,  $\text{msgs} = \{(1, (x, 1) \cdot (y, 1))\}$ . This is followed by  $\text{del}(p_1, t_1)$ , updating  $\text{ls}(p_1).\text{store}$  to  $x \mapsto 1, y \mapsto 1, z \mapsto 0$ , and  $\text{ls}(p_1).\text{ts}(x)$  as well as  $\text{ls}(p_1).\text{ts}(y) = 1$ . Next execute  $t_2$

choosing  $t_2.id = 2$ , resetting  $\text{ls}(p_1).\text{log}$ . The write  $z = 1$  results in  $\text{ls}(p_1).\text{log} = (z, 1)$ . The read in  $t_2$  picks up  $(x, 1)$  from the local store  $\text{ls}(p_1).\text{store}$  of  $p_1$  since the log does not have an  $x$  entry. At the end of  $t_2$ ,  $(2, (z, 1))$  is added to  $\text{msgs}$ , and we have  $\text{del}(p_1, t_2)$ , updating  $\text{ls}(p_1).\text{store}$  to  $x \mapsto 1, y \mapsto 1, z \mapsto 1$  and  $\text{ls}(p_1).\text{ts}(z) = 2$ .

Next execute  $t_3$  choosing  $t_3.id = 3$ . After the write to  $y$  in  $t_3$ ,  $\text{ls}(p_2).\text{log} = (y, 2)$ . The read in  $t_3$  picks  $(x, 0)$  from  $\text{ls}(p_2).\text{store}$ . At the end of  $t_3$ ,  $(3, (y, 2))$  is added to  $\text{msgs}$ , and we have  $\text{del}(p_2, t_3)$ , updating  $\text{ls}(p_2).\text{store}$  to  $x \mapsto 0, y \mapsto 2, z \mapsto 0$ , and  $\text{ls}(p_2).\text{ts}(y)$  to 3. This is followed by  $\text{del}(p_2, t_1)$ , delivering  $(1, (x, 1) \cdot (y, 1))$  to  $p_2$ . Since  $\text{ls}(p_2).\text{ts}(x) = 0 < 1 = t_1.id$ , the value  $x \mapsto 1$  is used to replace the local store of  $p_2$  wrt  $x$ . However since  $\text{ls}(p_2).\text{ts}(y) = 3 > 1 = t_1.id$ , the local store of  $p_2$  is not changed wrt  $y$ , and the value  $(y, 1)$  is not chosen from  $(1, (x, 1) \cdot (y, 1))$ . Thus,  $\text{ls}(p_2).\text{store}$  is updated to  $x \mapsto 1, y \mapsto 2, z \mapsto 0$ . This is followed by  $\text{del}(p_2, t_2)$ .  $z \mapsto 1$  will replace  $z \mapsto 0$  in  $\text{ls}(p_2).\text{store}$  since  $\text{ls}(p_2).\text{ts}(z) = 0 < 2 = t_2.id$ . Last, execute  $t_4$  choosing  $t_4.id = 4$ , and both reads happen from the local store  $\text{ls}(p_2).\text{store}$ .

## An Example to illustrate CC

Let us look at the program in Figure 8 for a CC execution. The transactions ids are ordered pairs (since we have 2 processes). The initial store for  $p_1$  and  $p_2$  is  $\{(x, 0, \text{init}), (y, 0, \text{init}), (z, 0, \text{init})\}$  the last component signifying that the value 0 is the initial value.

Begin with  $t_1.id = (1, 0)$ . At the end of  $t_1$ ,  $\text{ls.log}(p_1) = (x, 5) \cdot (x, 1) \cdot (y, 1)$ . Deliver  $t_1$  to  $p_1$ ,  $\text{del}(p_1, t_1)$  obtaining  $\{(x, 1, (1, 0)), (y, 1, (1, 0)), (z, 0, \text{init})\}$  as  $\text{ls.store}(p_1)$ . The only consistent snapshot from  $\text{ls.store}(p_1)$  is  $\text{ls.snapshot}(p_1)(x) = (1, (1, 0))$ ,  $\text{ls.snapshot}(p_1)(y) = (1, (1, 0))$  and  $\text{ls.snapshot}(p_1)(z) = (0, \text{init})$ .

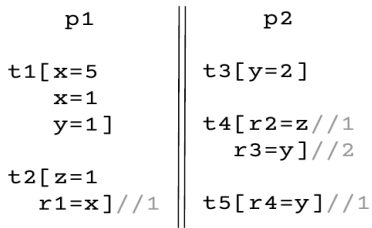

Fig. 8. CC Example, not CCv

Next execute  $t_2$  in  $p_1$ , with  $t_2.id = (1, 1)$  obtaining  $\text{ls.log}(p_1) = (z, 1)$ . The read is taken from the snapshot  $\text{ls.snapshot}(p_1)(x)$ . This is followed by  $\text{del}(p_1, t_2)$ . Next, execute  $t_3$  with  $t_3.id = (0, 1)$ . At the end of  $t_3$ ,  $\text{ls.log}(p_2) = (y, 2)$ . On  $\text{del}(p_2, t_3)$ , we obtain  $\text{ls.store}(p_2)$  as  $\{(x, 0, \text{init}), (y, 2, (0, 1)), (z, 0, \text{init})\}$ . Next deliver  $t_1$  to  $p_2$ ,  $\text{del}(p_2, t_1)$ . Then  $\{(x, 1, (1, 0)), (y, 1, (1, 0))\}$  should be added to  $\text{ls.store}(p_2)$ . Since  $t_1, t_3$  are concurrent, we obtain  $\text{ls.store}(p_2)$  as  $\{(x, 1, (1, 0)), (y, 1, (1, 0)), (y, 2, (0, 1)), (z, 0, \text{init})\}$ . Next, on  $\text{del}(p_2, t_2)$ ,  $(z, 1, (1, 1))$  replaces  $(z, 0, \text{init})$  in  $\text{ls.store}(p_2)$ . A consistent snapshot from  $\text{ls.store}(p_2)$  is  $\text{ls.snapshot}(p_2)(x) = (1, (1, 0))$ ,  $\text{ls.snapshot}(p_2)(y) = (2, (0, 1))$  and  $\text{ls.snapshot}(p_2)(z) = (1, (1, 1))$  considering the linearization  $t_3, t_1, t_2$ . Next execute  $t_4$  choosing  $t_4.id = (1, 2)$ . To read from  $z$  in  $t_4$ ,  $(z, 1)$  is picked up from  $\text{ls.snapshot}(p_2)(z)$ , likewise for reading  $y$ . Last, execute  $t_5$  choosing  $t_5.id = (2, 2)$ . Before executing  $t_5$ , calculate the snapshot wrt the store of  $p_2$ . Since  $t_3$  and  $t_1$  are concurrent,  $\text{ls.snapshot}(p_2)(y) = (1, (1, 0))$  considering the linearization  $t_3, t_1, t_2$ . Hence, when executing  $t_5$ ,  $r4$  can read 1.

Note that the above execution is not CCv. We need a total order among all transactions in CCv. if we choose  $t_1.id < t_3.id$  then  $t_5$  cannot read 1. Likewise if  $t_1.id > t_3.id$ , then  $t_2.id > t_3.id$ . This would imply that when  $t_2$  is delivered before  $t_4$  so that  $r2$  can read 1,  $t_1$  must have been delivered before  $t_2$  by causal delivery. Indeed with  $t_1.id > t_3.id$ ,  $t_4$  will not be able to read 2 from  $y$ , but only 1 from  $t_1$ . So both cases, we cannot read the expected values in  $t_4, t_5$ .

**Organization of the rest of the paper.** In the rest of the paper, to ease reading, we focus on the technical details needed for the CCv DPOR algorithm. The changes needed for CC are minor, and are described in the supplementary material. We report experimental details for CCv, CC in Section 7.

## 4 CCv AXIOMATIC SEMANTICS

As the first step towards the DPOR, we provide an axiomatic semantics for CCv. The main result of this section is the equivalence (Theorem 4.1) of the operational semantics for CCv [Beillahi et al. 2021b] and our axiomatic semantics.

**CCv Execution Summary.** As instructions within a transaction are not visible to other transactions and processes, we “summarize” the internal transitions in a transaction and only represent its overall effect. Given a CCv execution  $\rho$ , its *execution summary*  $\text{Sum}(\rho)$  is obtained by replacing every subsequence in  $\rho$  delimited by  $\text{begin}(p, t)$  and  $\text{end}(p, t)$  event labels with a single operation  $\text{isu}(p, t)$ .  $\text{isu}(p, t)$  represents *issuing* the transaction  $t$  in process  $p$ . Thus, the sequence of transitions  $\sigma_i \xrightarrow{\text{begin}(p, t)} \sigma_{i+1} \dots \xrightarrow{\text{end}(p, t)} \sigma_j$  is replaced with  $\sigma_i \xrightarrow{\text{isu}(p, t)} \sigma_j$ . The execution summary is a sequence of transitions over the events  $\text{EvSum}(\rho) = \{\text{isu}(p, t), \text{del}(p, t) \mid p \in P, t \in \mathcal{T}\}$ , and

begin(p1, t1)	begin(p1, t2)	begin(p2, t3)	begin(p2, t4)
w(p1, t1, x, 5)	w(p1, t2, z, 1)	w(p2, t3, y, 2)	r(p2, t4, z, 1)
w(p1, t1, x, 1) • del(p1, t1)	r(p1, t2, x, 1) • del(p1, t2)	r(p2, t3, x, 0) • del(p2, t3)	r(p2, t4, y, 2) • del(p2, t4)
w(p1, t1, y, 1)	end(p1, t2)	end(p2, t3)	end(p2, t4)
end(p1, t1)			

(a) A CCv execution for the program in Figure 7

$$\text{isu}(p1, t1) \cdot \text{del}(p1, t1) \cdot \text{isu}(p1, t2) \cdot \text{del}(p1, t2) \cdot \text{isu}(p2, t3) \cdot \text{del}(p2, t3) \cdot \text{del}(p2, t1) \cdot \text{del}(p2, t2) \cdot \text{isu}(p2, t4)$$

(b) Execution summary for above execution

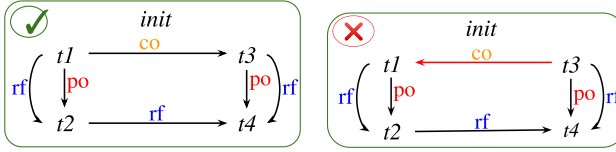

(c) CCv consistent trace

(d) CCv inconsistent trace

$$\text{isu}(p1, t1) \cdot \text{del}(p1, t1) \cdot \text{isu}(p1, t2) \cdot \text{del}(p1, t2) \cdot \text{del}(p2, t1) \cdot \text{del}(p2, t2) \cdot \text{isu}(p2, t3) \cdot \text{del}(p2, t3) \cdot \text{isu}(p2, t4)$$

(e) Another execution summary for trace 9(c)

Fig. 9. Execution summary and CCv traces for program given in Figure 7

induces a total ordering  $<$  on these events. Let  $(\text{EvSum}(\rho), <)$  denote the execution summary corresponding to execution  $\rho$  (see Fig.9(b) for the execution summary for the execution in Fig.9(a)). We say that a transaction  $t$  executed by process  $p$  writes  $x$  at process  $p'$  if  $t \in \mathcal{T}^{w,x}$  and the execution summary contains the event  $\text{del}(p', t)$  which is not preceded by  $\text{del}(p', t')$  with  $t.id < t'.id$  and  $t' \in \mathcal{T}^{w,x}$ .

An execution summary  $S = (\text{EvSum}(\rho), <)$  induces two functions capturing the *happens-before*  $S.hb$  and *read from the latest write*  $S.lw$  relations.

- $S.hb : \mathcal{T}(\rho)^r \rightarrow \mathfrak{p}(\mathcal{T}(\rho)^w)$  s.t.  $S.hb(t_1) = \{t' \in \mathcal{T}(\rho)^w \mid \text{del}(p, t') < \text{isu}(p, t_1), p \in P\}$ . Thus,  $S.hb(t_1)$  is the set of all transactions  $t'$  which have a write operation, and were delivered before executing  $t_1$ .
- $S.lw : \mathcal{T}(\rho)^r \times \mathcal{V} \rightarrow \mathcal{T}(\rho)^w$ , defined by  $S.lw(t_1, x) = \{t' \mid t' \in S.hb(t_1) \cap \mathcal{T}(\rho)^{w,x}, t_1 \in \mathcal{T}(\rho)^{r,x} \text{ and } \forall t'' \in S.hb(t_1) \cap \mathcal{T}(\rho)^{w,x}, t'.id \geq t''.id\}$ . For a transaction  $t_1 \in \mathcal{T}(\rho)^{r,x}$ ,  $S.lw(t_1, x)$  is the last (based on the ordering of transaction ids) transaction  $t'$  to have written on  $x$  before executing  $t_1$ .

**CCv Legal Summaries.** An execution summary  $S = \text{Sum}(\rho)$  is *legal* under CCv iff:

- (1) Each  $t \in \mathcal{T}$  in the domain of  $S.lw$  reads from the latest write, that is,  $S.lw(t, x)$  for all  $x$ ;
- (2) For all  $t \in \mathcal{T}(\rho)^w$ , if  $\text{del}(p, t) < \text{isu}(p, t')$ , then  $\text{del}(p', t) < \text{del}(p', t')$  for all processes  $p, p'$ ; and,
- (3) For each  $t \in \mathcal{T}$  and processes  $p, p'$ ,  $\text{isu}(p, t) < \text{del}(p', t)$ .

**Traces.** A trace is an abstract representation of an execution summary. For a concurrent program  $\mathcal{P}$  with transactions  $\mathcal{T}$ , a trace is defined as a graph  $(\mathcal{T}, po, rf, co)$  where the transactions are the nodes, and the relations  $po, rf, co$  form edges between the nodes. For transactions  $t \neq t'$ , define  $(t, t') \in po$  (or  $t[po]t'$ ) when  $t$  and  $t'$  are in the same process  $p \in P$  and  $t.id < t'.id$ .  $po$  does not relate the initializer transactions.  $(t, t') \in rf$  (or  $t[rf]t'$ ) relates transactions  $t \neq t'$  where  $t'$  reads from  $t$  on some variable  $x \in \mathcal{V}$ . The variable  $x$  can be made explicit by defining  $(t, t') \in rf^x$  (or

$t[rf]^x t'$ , with  $rf = \bigcup_{x \in \mathcal{V}} rf^x$ . Lastly,  $(t, t') \in co$  (or  $t[co]t'$ ) if  $t \neq t' \in \mathcal{T}^{w,x}$  for some  $x \in \mathcal{V}$ , and  $t'$  writes to  $x$  after  $t$ . The transaction  $init_x$  is such that  $init_x[co]t$  for all transitions  $t \in \mathcal{T}(\rho)^{w,x}$ .

Let  $[po \cup rf \cup co]^+$  (resp.,  $[po \cup rf \cup co]^*$ ) denote the transitive (reflexive) closure of  $[po \cup rf \cup co]$ . If  $t [po \cup rf \cup co]^+ t'$ , then  $t$  happens before  $t'$ .

**Total and Partial Traces for CCv.** A trace  $\tau = (\mathcal{T}, po, rf, co)$  is *total* (denoted  $\text{total}(\tau)$ ) iff the relation  $co^x$  for each variable  $x$  is a total order on  $\mathcal{T}^{w,x}$ . A *partial* trace is arbitrary, and need not be total.

**$\tau$ -consistent CCv Execution Summaries.** Given an *execution summary*  $\rho = \sigma_0 \xrightarrow{\ell_1} \sigma_1 \xrightarrow{\ell_2} \sigma_2 \xrightarrow{\ell_3} \sigma_3 \cdots \xrightarrow{\ell_{n-1}} \sigma_{n-1} \xrightarrow{\ell_n} \sigma_n$ , and a trace  $\tau = (\mathcal{T}, po, rf, co)$ ,  $\rho$  is  $\tau$ -consistent (denoted  $\rho \models \tau$ ) if the following holds:

- Each transaction  $t \in \mathcal{T}$  corresponds to exactly one label  $\text{isu}(-, t)$  in  $\rho$ .
- For  $t, t' \in \mathcal{T}$ , if  $t[po]t'$ , then  $\exists \ell_i = \text{isu}(p, t), \ell_j = \text{isu}(p, t')$  with  $i < j$  in  $\rho$ .
- For  $t, t' \in \mathcal{T}$ , if  $t[co]t'$ , then there exist  $\ell_i = \text{isu}(p, t), \ell_j = \text{isu}(p', t')$ , with  $i < j$  such that  $t, t' \in \mathcal{T}^{w,x}$  for some  $x \in \mathcal{V}$ .
- For  $t \neq t' \in \mathcal{T}$ , if  $t[rf]t'$ , then  $\exists \ell_i = \text{isu}(p', t), \ell_j = \text{del}(p, t), \ell_k = \text{isu}(p, t'), i < j < k$ , such that (i)  $t \in \mathcal{T}^{w,x}, t' \in \mathcal{T}^{r,x}$  for some  $x \in \mathcal{V}$ , and  $p'$  writes  $x$  at process  $p$ , (ii)  $\neg(\exists \ell_m = \text{del}(p, t''), j < m < k \wedge t'' \in \mathcal{T}^{w,x} \wedge t'[co^x]t'')$ .

**Partially Good, CCv consistent Traces.** For a trace  $\tau = (\mathcal{T}, po, rf, co)$ , define  $\tau \models \text{CCv}$  iff (i)  $\forall x \in \mathcal{V}, t_1, t_3 \in \mathcal{T}^{w,x}, t_2 \in \mathcal{T}^{r,x}$ , if  $(t_1, t_2) \in rf^x, (t_3, t_2) \in [po \cup rf]^+$ , then  $(t_3, t_1) \in co^x$ , and (ii)  $[po \cup rf \cup co]^+$  is irreflexive. A partial trace  $\tau$  satisfying  $\tau \models \text{CCv}$  is a **partially good** trace. A partial trace  $\tau$  is **CCv consistent** iff it can be extended to a total trace s.t.  $\tau \models \text{CCv}$ .

For a configuration  $\sigma$ , let  $[[\sigma]]_{\text{CCv}} = \{\tau \mid \exists \rho \in \text{ExecFrom}(\sigma), \rho \models \tau \text{ and } \tau \text{ is CCv consistent}\}$  denote the set of all CCv consistent traces from a configuration  $\sigma$ . The trace shown in figure 9(d) is not CCv consistent for program execution given in Figure 9(a) since  $t3[rf]^y t4$  and  $t1[po \cup rf]^+ t4$ , we can not have  $t3[co]^y t1$ .

**THEOREM 4.1.** *A (partial) trace  $\tau$  is CCv-consistent iff there is a legal and  $\tau$ -consistent execution summary  $S$  corresponding to  $\tau$ .*

As seen in Figure 9, a single CCv consistent trace can represent different executions : the CCv consistent trace in Figure 9(c) represents executions with summaries as in Figure 9(b) and 9(e). Exploring all executions of transactional programs under CCv can be achieved by generating all traces in  $[[\sigma]]_{\text{CCv}}$  exactly once. We can do better than exploring all traces, by observing that the outcome of assert statements on local states only depend on  $po$  and  $rf$  relations irrespective of the  $co$  relation. Hence two execution (summaries) whose traces have the same  $po, rf$  relations are regarded equivalent. We propose a DPOR algorithm that explores traces by considering only the  $po, rf$  relations and such traces are called *weak traces*.

**Weak traces.** A trace is called a *weak trace*, if its  $co$  relation is empty. A weak trace is obtained by removing all  $co$  edges from a trace  $\tau = \langle \mathcal{T}, po, rf, co \rangle$  and this trace is denoted as  $\text{weak}(\tau)$ . We define  $[[\sigma]]_{\text{CCv}}^{\text{weak}} = \{\text{weak}(\tau) \mid \tau \in [[\sigma]]_{\text{CCv}}\}$  as the set obtained by weakening traces in  $[[\sigma]]_{\text{CCv}}$ . A trace  $\tau = \langle \mathcal{T}, po, rf, co \rangle$  is *weaker than* a trace  $\tau' = \langle \mathcal{T}', po', rf', co' \rangle$ , denoted by  $\tau \sqsubseteq \tau'$ , if  $\mathcal{T} = \mathcal{T}'$ ,  $po = po', rf = rf'$  and  $co \subseteq co'$ .

Section 6 presents our DPOR algorithm where executions are explored until all weak traces in  $[[\sigma]]_{\text{CCv}}^{\text{weak}}$  have been generated. Towards the optimality of our algorithm in terms of the number of traces explored, in Section 5, we show how to ensure that each trace in  $[[\sigma]]_{\text{CCv}}^{\text{weak}}$  is explored exactly once. While extending these weak traces, the CCv consistency is guaranteed by defining a fulfilled semantics (Section 5) equivalent with the CCv semantics. In the fulfilled semantics, executions are



associated to partial traces that contain only those **co** edges which must be necessarily present in any corresponding CCv consistent total trace.

## 5 FULFILLED SEMANTICS FOR CCv

The main contribution of this section is a notion of *fulfilled semantics*, which enables us to explore only weak traces  $[[\sigma]]_{\text{CCv}}^{\text{weak}}$  which are CCv consistent, from a configuration  $\sigma$ . To achieve this, we first define *fulfilled traces*.

**Fulfilled Traces.** A fulfilled trace is a partial trace which extends a weak trace  $\zeta$ , and carefully selects which **co** edges are to be added in each step, as we go towards a total trace.

Formally, a trace  $\tau = \langle \mathcal{T}, \text{po}, \text{rf}, \text{co} \rangle$  is called *fulfilled* if, for all transactions  $t, t' \in \mathcal{T}^w$ ,  $t \neq t'$ , and all variables  $x \in \mathcal{V}$ , whenever  $t [\text{po} \cup \text{rf}]^+ t t''$  and  $t' [\text{rf}^x] t''$ , then  $t [\text{co}^x]^+ t'$ : note that allowing  $t' [\text{co}^x]^+ t$  results in a cycle violating CCv. Note that any trace  $\tau$  s.t.  $\tau \models \text{CCv}$  is fulfilled, but the converse is not true. One can have  $\tau$  s.t. (1) for all  $t, t' \in \mathcal{T}^w$ ,  $x \in \mathcal{V}$   $[t [\text{po} \cup \text{rf}]^+ t t'' \wedge t' [\text{rf}^x] t'' \Rightarrow t [\text{co}^x]^+ t']$ , and (2)  $t' [\text{po} \cup \text{rf} \cup \text{co}]^+ t$ . By (1)  $\tau$  is fulfilled, but (2) creates a  $[\text{po} \cup \text{rf} \cup \text{co}]^+$  cycle violating CCv.

**THEOREM 5.1.** *A partial trace is CCv-consistent if, it is fulfilled and partially good.*

Theorem 5.1 shows that partially good traces  $\tau$  can be extended to total CCv consistent traces. The challenge is to add *only* those **co** edges to ensure CCv is not violated.

### 5.1 Fulfilled Semantics : Extending Partially Good, Fulfilled Traces

Our DPOR algorithm (section 6) proceeds by extending partially good fulfilled traces, to obtain CCv consistent total traces. For this, we work on a transition system whose states are pairs  $(\sigma, \tau)$  where  $\sigma$  is a configuration of the concurrent program  $\mathcal{P}$  and  $\tau$  is a (partial) trace. The *fulfilled semantics* is given as the transition relation  $\rightarrow_{\text{ful}}$ , defined as  $(\sigma, \tau) \xrightarrow{\alpha}_{\text{ful}} (\sigma', \tau')$ . The label  $\alpha$  is one of  $(\text{begin}, t)$ ,  $(\text{end}, t)$ ,  $(\text{read}, t, t')$ ,  $(\text{write}, t)$ . An important property of  $(\sigma, \tau) \xrightarrow{\alpha}_{\text{ful}} (\sigma', \tau')$  is that if  $\tau$  is fulfilled and CCv-consistent so is  $\tau'$ . By Theorem 5.1, all traces generated by the fulfilled semantics are CCv-consistent.

For  $\tau = \langle \mathcal{T}, \text{po}, \text{rf}, \text{co} \rangle$ ,  $\tau' = \langle \mathcal{T}', \text{po}', \text{rf}', \text{co}' \rangle$ , we describe the transitions  $(\sigma, \tau) \xrightarrow{\alpha}_{\text{ful}} (\sigma', \tau')$ .

- From a state  $(\sigma, \tau)$ , assume that we observe the  $\text{begin}(p, t)$  event. Then, the label  $\alpha$  is  $(\text{begin}, t)$ , and we have  $\mathcal{T}' = \mathcal{T} \cup \{t\}$ ,  $\text{rf}' = \text{rf}$ ,  $\text{co}' = \text{co}$  and  $\text{po}' = \text{po} \cup t' [\text{po}] t$  where  $t', t$  are transactions in the same process  $p$ ,  $t'$  is the last transaction executed in  $p$ , and  $t$  is the next transaction in **po** order of  $p$ . Fig.11(a) illustrates the effect of observing a  $\text{begin}(p, t7)$  event, where  $t7$  is the new transaction added to the trace. In Fig.11(a), assuming  $t1$  is the last transaction execution from process  $p$ , we add **po** edge from  $t1$  to  $t7$ .
- On events  $w(p, t, x, v)$ ,  $\text{end}(p, t)$ , the state does not change.
- From a state  $(\sigma, \tau)$ , assume that we observe the  $ev = r(p, t, x, v)$  event in transaction  $t$ . In this case, the label  $\alpha$  is  $(\text{read}, t, t')$ , where  $t'$  is the transaction from which  $t$  reads from, so that the trace  $\tau'$  in the target state  $(\sigma', \tau')$ , remains *fulfilled* and CCv consistent. The transactions  $t'$  which qualify to be read from are prescribed using the *readable* sets  $\text{readable}(\tau, t, x)$ .

**Readable sets to respect CCv consistency.** A readable set  $\text{readable}(\tau, t, x)$  contains all those transactions  $t'$  from which a read event on  $x$  of transaction  $t$  can read from, so that, on adding the edge  $(t', t)$  to **rf'**, the resultant trace  $\tau'$  is partially good and fulfilled. To allow  $t' \in \text{readable}(\tau, t, x)$ , we check a condition  $\neg \text{cond1} \wedge \neg \text{cond2} \wedge \neg \text{cond3} \wedge \neg \text{cond4}$  where  $\text{cond1}$ ,  $\text{cond2}$ ,  $\text{cond3}$  and  $\text{cond4}$  are described below. These 4 conditions are sufficient to ensure that  $\tau'$  is fulfilled and partially good (Lemma 5.2). Checking for each of  $\text{cond1}$ ,  $\text{cond2}$ ,  $\text{cond3}$ ,  $\text{cond4}$  takes time  $\leq O(|\mathcal{T}|^2)$ .

For transactions  $t \in \mathcal{T}^{r,x}$ ,  $t' \in \mathcal{T}^{w,x}$ ,  $x \in \mathcal{V}$ , to allow  $t' [\text{rf}'^x] t$ , we check the following :

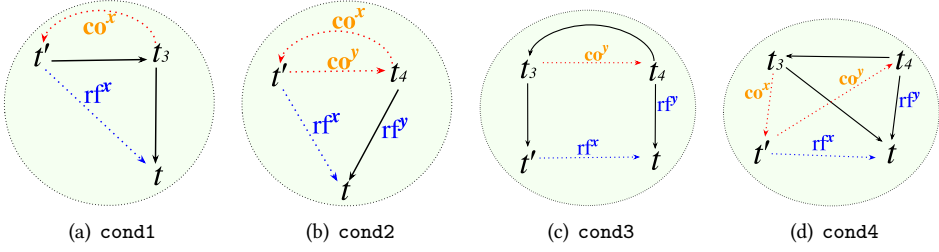

Fig. 10. CCv violating reads.

- (1) Let  $\text{cond1} = \exists t_3 \in \mathcal{T}^{w,x}$  such that  $t' [po \cup rf \cup co]^+ t_3 [po \cup rf]^+ t$ . We then check  $\neg \text{cond1}$  to ensure  $t$  reads from the transaction which wrote last to  $x$ . If we allow  $t' [rf^x] t$ , then  $t_3 \in \mathcal{T}^{w,x}$  induces  $t_3 [co^x] t'$ , resulting in a CCv violating cycle  $t' [co] t_3 [co^x] t'$ . Thus, To allow  $t' [rf^x] t$ , we check  $\neg \text{cond1}$ , see Figure 10(a).
- (2) Let  $\text{cond2} = \exists t_4, \exists y \in \mathcal{V}[t', t_4 \in \mathcal{T}^{w,y} \cap \mathcal{T}^{w,x} \wedge t_4 [rf^y] t]$ .  $\text{cond2}$  considers the case when  $t$  has read from a transaction  $t_4$  wrt  $y \neq x$ , and both transactions  $t', t_4$  write on both  $x, y$ .  $t_4 [rf^y] t$  and  $t' \in \mathcal{T}^{w,y}$  induces  $t' [co^y] t_4$  for CCv consistency of  $\tau'$ . If we allow  $t' [rf^x] t$ , then  $t_4 \in \mathcal{T}^{w,x}$  induces  $t_4 [co^x] t'$ , resulting in a CCv violating cycle  $t' [co] t_4 [co^x] t'$ . Thus, to allow  $t' [rf^x] t$ , we check  $\neg \text{cond2}$ , see Figure 10(b).
- (3) Assume  $t' \in \mathcal{T}^{w,x} \cap \mathcal{T}^{w,y}$ . To allow  $t' [rf^x] t$ , we check the following conditions  $\neg \text{cond3}$  and  $\neg \text{cond4}$  are true. Intuitively,  $\text{cond3}$  (3(a)) and  $\text{cond4}$  (3(b)) check that allowing  $t' [rf^x] t$  will not induce a CCv violating cycle, by considering existing  $rf^y$  relations  $t$  has wrt  $y \neq x$  and a transaction  $t_4$  (say  $t_4 [rf^y] t$ ). We analyze the  $[po \cup rf \cup co]^+$  paths from  $t_4$  to  $t', t$ .
  - (a) Assume we have a  $t_4 [po \cup rf \cup co]^* t'$  path s.t. there is  $t_3 \in \mathcal{T}^{w,y}$  in this path. Here,  $t_3$  can coincide with  $t'$  or can be  $co$ -after  $t_4$ .  
 $\text{cond3} = [\exists t_3, t_4 \text{ s.t. } t_4 [rf^y] t, t_4 [po \cup rf \cup co]^+ t_3 [po \cup rf]^* t']$  with  $t_3 \in \mathcal{T}^{w,y}$ .  
 If  $\text{cond3}$  is true, then allowing  $t' [rf^x] t$ , creates a CCv violation, as shown below.
    - Case 1: If  $t_3 = t'$ ,  $t_4 [po \cup rf \cup co]^+ t'$  and  $t' [po' \cup rf']^+ t$  imply  $t' [co^y] t_4$  (to respect  $\tau' \models \text{CCv}$ ). This results in a cycle  $t_4 [po \cup rf \cup co]^+ t' [co] t_4$ , violating CCv.
    - Case 2 : If  $t_3 \neq t'$ , then  $t_3 [po \cup rf]^* t'$  along with  $t' [rf^x] t$  will give  $t_3 [po \cup rf]^+ t$ . Along with  $t_4 [rf^y] t$ , we obtain  $t_3 [co^y] t_4$  by CCv consistency. This results in the cycle  $t_4 [po \cup rf]^+ t_3 [co^y] t_4$ , violating CCv consistency. See Figure 10(c).
  - (b) Assume we have a  $t_4 [po \cup rf \cup co]^+ t$  path s.t. (i) there is a transaction  $t_3 \in \mathcal{T}^{w,x}$  in this path, and (ii)  $t_3$  is the last transaction writing to  $x$  in this path.  
 $\text{cond4} = [\exists t_3, t_4 \text{ s.t. } t_4 [rf^y] t, t_4 [po \cup rf \cup co]^+ t_3 [po \cup rf]^+ t]$ , with  $t_3 \in \mathcal{T}^{w,x}$  and, there is no transaction  $t'' \in \mathcal{T}^{w,x}$  such that  $t_3 [po \cup rf \cup co]^+ t'' [po \cup rf]^+ t$ .  
 If  $\text{cond4}$  is true, then allowing  $t' [rf^x] t$  creates a CCv violation as shown below.  $t' [rf^x] t$  and  $t_3 [po \cup rf]^+ t$  gives us  $t_3 [co^x] t'$ , while  $t_4 [rf^y] t$  and  $t' [rf^x] t$  gives us  $t' [co^y] t_4$ , and thus the cycle  $t_3 t' t_4 t_3$  violating CCv consistency. See Figure 10(d).

Once we select a readable transaction  $t' \in \text{readable}(\tau, t, x)$ , and add  $t' [rf^x] t$  obtaining a trace  $\tau'$ , in order to keep  $\tau'$  fulfilled, we should add some  $co$  edges to  $t'$ . Next, we find out which  $co$  edges are necessary to be added.

**Necessary  $co$  edges to maintain fulfilled traces.** A visible set  $\text{visible}(\tau, t, x)$  consists of all  $t'' \in \text{readable}(\tau, t, x)$  which can reach  $t$  via  $po, rf$  edges. If we have  $(\sigma, \tau) \xrightarrow{\text{read}, t, t'}_{\text{ful}} (\sigma', \tau')$ , then to maintain fulfilled-ness of  $\tau'$ , (1) we must add new  $co$  edges from all  $t'' \in \text{visible}(\tau, t, x)$



semantics and the fulfilled semantics coincide on weak traces. Thus, it suffices to explore traces according to the fulfilled semantics, where **co** edges are added only when necessary. As seen already, the fulfilled semantics results in new traces which are not only fulfilled but also partially good, leading to CCv consistent traces. This constitutes the core of the soundness of our DPOR algorithm.

**THEOREM 5.5.** *For any configuration  $\sigma$ ,  $\{\text{weak}(\tau) \mid \tau \in [[\sigma]]_{\text{CCv}}^{\text{ful}}\} = [[\sigma]]_{\text{CCv}}^{\text{weak}}$ .*

## 6 CCv DPOR ALGORITHM

We present our DPOR algorithm, which systematically explores, for any terminating program, all weak traces which can be generated by the fulfilled semantics. The main procedure is Algorithm 1.

**Procedure - ExploreTraces.** This procedure takes as input, a configuration  $\sigma$ , a fulfilled trace  $\tau$  and an observation sequence  $\pi$ .  $\pi$  is a sequence of events  $ev \in \{(\text{begin}, t), (\text{end}, t), (\text{write}, t), (\text{read}, t, t')\}$ . Events from the same transaction appear contiguously in  $\pi$ . For read events  $ev = (\text{read}, t, t')$ , the value of the Boolean flag  $\text{localread}(ev)$  checks if  $t = t'$ , that is,  $ev$  reads from a write  $e_W$  of the same transaction. A Boolean array  $\text{locally}[\ ]$  of size  $|\mathcal{V}|$  is reset to FALSE for all variables at the start of any transaction; when a write event on  $x$  takes place in the current transaction, then  $\text{locally}[x]$  is set to TRUE. This signifies the local availability of an  $(x, v)$  in the log. We also maintain a map  $\text{currentreads}$  from variables to transactions :  $\text{currentreads}[x] = t'$  means that  $x$  read from transaction  $t'$ ; hence, all later read events of  $x$  in the current transaction  $t$  must read from  $t'$ , unless  $t$  writes to  $x$  between an earlier read (from  $t'$ ) and the next read. Initially, *ExploreTraces* is invoked with initial configuration  $\sigma_0$ , empty trace  $\tau_0$  and observation sequence  $\pi = \epsilon$ . From the initial  $(\sigma_0, \tau_0)$ , we choose according to the fulfilled semantics, a transaction  $t'$  by adding  $\text{begin}(t')$  to  $\pi$ , and call on *ExploreTraces* to continue (lines 4-8, Algorithm 1). Let  $e$  be the last event of  $\pi$  (line 2, Algorithm 1). If  $e \neq \text{end}(t')$  then add the next event  $e'$  (read, write or end) from transaction  $t = e.\text{trans}$  to the observation sequence  $\pi$ , updating it to  $\pi.e'$ .

- If  $e'$  writes on  $x$ , set  $\text{locally}[x]$  TRUE, update  $\pi \leftarrow \pi.e'$  and recursively call on *ExploreTraces* (lines 11-12). Subsequent reads on  $x$  from transaction  $t$  will hence read from  $t$ .
- Let  $e' = r(p, t, x, v)$  be a read event on  $x$  in transaction  $t$ .
  - If  $e'$  can read from its transaction log due to an earlier write on  $x$  in  $t$ , then the trace is not updated (lines 14-16).
  - If  $e'$  cannot read from its transaction log it checks if  $\text{currentreads}[x]$  is assigned some transaction  $t'$ , and in that case, reads from  $t'$  (lines 17-19). In this case,  $\text{Swappable}(e')$  is FALSE, indicating that there is no need to look for a source transaction to read from.
  - If  $e'$  cannot read from its transaction log and  $\text{currentreads}[x]$  is empty, then the set  $\text{schedules}(e')$  is initialized and the Boolean flag  $\text{Swappable}(e')$  is set to TRUE (lines 20-22).  $\text{Swappable}(e')$  being TRUE indicates that we must find according to the fulfilled semantics, readable transactions  $t' \in \mathcal{T}^{w,x}$  where  $e'$  can read from, leading to  $(\sigma', \tau')$ . For each such  $t'$ , let  $\pi = \zeta \cdot (\text{begin}, t) \dots (\text{read}, t, t')$  be the observation sequence obtained on choosing to read from  $t'$ .  $\text{currentreads}[x]$  is set to  $t'$  and *ExploreTraces* $(\sigma', \tau', \pi)$  is called recursively (line 24). If transaction  $t'$  has not yet appeared in  $\pi$ , the write in  $t'$  is called a *postponed write*.
- If  $e'$  is  $(\text{end}, t)$ , then we recursively call on *ExploreTraces* after appending  $(\text{end}, t)$  to  $\pi$ , exploring other transactions. When the recursive calls return to this point when the last event of  $\pi$  is  $(\text{end}, t)$ , we do the following. Corresponding to the last write for each variable in transaction  $t$ , we call *CreateSchedule*. This call enables us to pair these write events as potential sources to be read from, for the read operations of transactions which are dependent on postponed write operations. This call also creates schedules for such read operations which are identified in *CreateSchedule*. These schedules are then explored when the recursive call to *ExploreTraces* returns at line 25. For a read

**Algorithm 1:** *ExploreTraces*( $\sigma, \tau, \pi$ )

---

**Input:**  $\sigma$  is a configuration,  $\tau$  is a trace  $\langle \mathcal{T}, po, rf, co \rangle$ , and  $\pi$  is an observation sequence

```

1 if  $\neg \text{empty}(\pi)$  then
2    $e := \text{last}(\pi)$ , let  $t = e.\text{trans}$ ,  $p = t.\text{process}$  /*  $t.\text{process} = \text{process of transaction } t$  */
3 if  $\text{empty}(\pi) \vee e \text{ is end}(p, t)$  then
4   if  $\exists(\sigma, \tau) \rightarrow (\sigma', \tau')$  then
5     let  $t'$  be the transaction  $t'.\text{process} = p'$ 
6      $(t'.\text{id} > \text{largest timestamp in local store of } p', \text{ s.t. } (\sigma, \tau) \xrightarrow{(\text{begin}, t')}_{\text{ful}} (\sigma', \tau'))$ 
7      $\pi := \pi \cdot (\text{begin}, t')$ ,  $\text{locally}[x] \leftarrow \text{FALSE}$ ,  $\text{currentreads}[x] \leftarrow \emptyset$ 
8     ExploreTraces( $\sigma', \tau', \pi$ )
9 else
10    we are not yet at the end of  $t$ , let  $e'$  be next event in transaction  $t$ 
11    if  $e' = w(-, t, x, -)$  then
12       $\text{locally}[x] := \text{TRUE}$ ;  $\pi := \pi \cdot (\text{write}, t)$ ; ExploreTraces( $\sigma, \tau, \pi$ )
13    if  $e' = r(-, t, x, -)$  then
14      if  $\text{locally}[x]$  then
15        /* itself has a write on  $x$  */
16         $\text{localread}(e') \leftarrow \text{TRUE}$ ;  $\pi := \pi \cdot (\text{read}, t, t)$ ; ExploreTraces( $\sigma, \tau, \pi$ )
17      else if  $\text{currentreads}[x]$  then
18        /*  $t$  has no writes on  $x$ , but  $e'$  can read from a  $t'$  which has been executed */
19         $\pi := \pi \cdot (\text{read}, t, \text{currentreads}[x])$ ;  $\text{Swappable}(e') \leftarrow \text{FALSE}$ ; ExploreTraces( $\sigma, \tau, \pi$ )
20      else
21        /* find a transaction  $t'$  from where  $e'$  can read, and swap execution of  $t, t'$  */
22         $\text{Schedules}(e') \leftarrow \cdot$ ,  $\text{Swappable}(e') \leftarrow \text{TRUE}$ 
23        for  $t'$  and  $\tau' : (\sigma, \tau) \xrightarrow{(\text{read}, t, t')}_{\text{ful}} (\sigma', \tau')$  do
24           $\pi := \pi \cdot (\text{read}, t, t')$ ;  $\text{currentreads}[x] := t'$ ; ExploreTraces( $\sigma', \tau', \pi$ )
25        for  $\beta \in \text{Schedules}(e')$  do
26           $\text{RunSchedule}(\sigma, \tau, \pi', \beta)$  where  $\pi = \pi' \cdot (\text{begin}, t) \dots (\text{read}, t, t')$ 
27      else
28        /*  $e'$  is the end event */
29         $\pi := \pi \cdot (\text{end}, t)$ ; ExploreTraces( $\sigma, \tau, \pi$ )
30      if transaction  $t$  has at least one write event then
31        for each  $x \in \mathcal{V}$  CreateSchedule( $\tau, \pi$ ) for the last write on  $x$  in  $t$ 
32
```

---

event  $e'$  in a transaction  $t$ , each schedule  $\beta \in \text{schedules}(e')$  explores a new source transaction  $t'$  to read from, and extends the trace.

**Algorithm 2** *CreateSchedule*. *CreateSchedule* is called when we are at an  $e = (\text{end}, t_2)$  event of a transaction  $t_2 \in \mathcal{T}^w$  in an observation sequence  $\pi$ . The inputs are a fulfilled trace  $\tau$ , and observation sequence  $\pi$ . *CreateSchedule* enables a read event occurring in a transaction  $t_1$  which precedes a transaction  $t_2$  in  $\pi$ , to read from a write event in  $t_2$ . We start from  $(\text{end}, t_2)$  in  $\pi$ , and traverse  $\pi$  backwards, until we cross  $\pi[k] = (\text{begin}, t_2)$  (line 2, Algorithm 2). We continue going back in  $\pi$  and find a read event  $e' = \pi[i]$ ,  $1 \leq i < k - 1$  on a variable  $x$  in a transaction  $t_1 \neq t_2$  which has appeared before  $\pi[k]$ , such that

- $\text{swappable}(e')$  is true, and  $\text{localread}(e')$  is false (line 4). The latter condition ensures that there are no writes in  $t_1$  on the variable of interest for  $e'$ , which precedes the read  $e'$ , while the former ensures that the read is pending.
- $t_1 = e'.\text{trans}$ , should not happen before  $t_2$ , that is,  $(\neg t_1[po \cup rf]^+ t_2)$ , (line 6)
- There is no *co*-cycle( $t_1, t_2$ ) (line 8): that is, there is no  $y \in \mathcal{V}$  and transaction  $t''$  s.t.  $[t''[rf]^y t_1 \wedge t_2 \in \mathcal{T}^{w,y} \wedge t'' \in \mathcal{T}^{w,x}]$ .
- $t_2$  does not overwrite reads made by  $t_1$  wrt  $x$  (line 8). Let  $\text{overwrite}(t_2, t_1)$  be the formula  $\exists t'' \in \mathcal{T} \cdot \exists y \in \mathcal{V} \cdot [t''[rf]^y t_1 \wedge t_2 \in \mathcal{T}^{w,y} \wedge t''[po \cup rf]^+ t_2]$  which says that  $t_2$  overwrites some variable  $y$  which has been read by  $t_1$  from some  $t''$ .



**Algorithm 2:** *CreateSchedule*( $\tau, \pi$ )

---

```

Input: Trace  $\tau = \langle \mathcal{T}, po, rf, co \rangle$ , and observation sequence  $\pi$ 
1 let  $e$  be the last event in  $\pi$ , and  $t_2 := e.trans$  be the transaction of  $e$ 
2 let  $k$  be the index of event  $(begin, t_2)$  in  $\pi$ 
3 for all transactions  $t_1$  appeared before  $t_2$  in  $\pi$  do
4   if  $\exists e' \cdot (e' = r(-, t_1, x, -) \wedge \neg(localread(e')) \wedge Swappable(e'))$  then
5     /*  $e'$  is a read event in  $t_1$  and needs a write from another transaction to read */
6     if  $\neg(t_1 [po \cup rf]^+ t_2)$  then
7       /*  $t_1$  does not happen before  $t_2$  */
8       if  $\neg(overwrite(t_2, t_1) \wedge \neg co-cycle(t_1, t_2))$  then
9         /*  $t_2$  does not overwrite any variable read by  $t_1$  (from any  $t''$ ) earlier */
10         $\beta \leftarrow \epsilon$  /*  $t_2$  is a good choice; Initialize the schedule  $\beta$  */
11         $flag = 1$ 
12        let  $j$  be the index of  $(end, t_1)$  in  $\pi$ 
13         $j := j + 1$ 
14        while  $j \neq (|\pi| - 1)$  do
15          let  $e'' := \pi[j]$  and  $t'' = e''.trans$ 
16          if  $t'' [po \cup rf]^+ t_2$  then
17            /* transactions  $t''$  in  $\pi$  after  $end(-, t_1)$ , before  $begin(-, t_2)$  happen before  $t_2$  */
18            if  $t_1 [po \cup rf]^+ t'' \vee overwrite(t'', t_1)$  then
19               $\beta \leftarrow \epsilon$  /* we cannot include this schedule */
20               $flag = 0$ 
21              break
22            /*  $t''$  can be in the schedule */
23            while  $\pi[j] \neq (end, t'')$  do
24               $\beta \leftarrow \beta \cdot \pi[j]$ 
25               $j := j + 1$ 
26               $\beta \leftarrow \beta \cdot \pi[j]$  /* append schedule with  $t''$  events */
27            else
28              /*  $t''$  is not happening before  $t_2$ , proceed to transactions after  $t''$  in  $\pi$  */
29              while  $\pi[j] \neq (end, t'')$  do
30                 $j := j + 1$ 
31               $j := j + 1$ 
32          if  $flag \neq 0$  and Schedules( $e'$ ) does not contain schedule  $\alpha = \beta \cdot (begin, t_2) \dots (end, t_2) \cdot (begin, t_1) \dots (read, t_1, t_2)$  then
33            schedules( $e'$ )  $\leftarrow$  schedules( $e'$ )  $\cup \{\alpha\}$ 

```

---

**Algorithm 3:** *RunSchedule*( $\sigma, \tau, \pi, \beta$ )

---

```

Input:  $\sigma$  is a configuration,  $\tau$  is a trace,  $\pi$  is an observation sequence and  $\beta$  is a schedule
1 if  $\beta$  is non-empty then
2   let  $\beta$  be  $\alpha \cdot \beta'$ 
3   let  $\alpha$  be the observation sequence for transaction  $t$ 
4   choose  $\sigma', \tau' : \langle \sigma, \tau \rangle \xrightarrow{\alpha}_{F_{UI}} \langle \sigma', \tau' \rangle$ 
5   for all read events  $e \in t$  do
6      $Swappable(e) \leftarrow FALSE$ 
7    $\pi' = \pi \cdot \alpha$ 
8   RunSchedule( $\sigma', \tau', \pi', \beta'$ )
9 else
10  ExploreTraces( $\sigma, \tau, \pi$ )

```

---

When lines 4,6,8 hold, we create a schedule  $\beta$  for  $e'$  by swapping  $t_2$  with  $t_1$  in  $\pi$ . First, initialize the schedule  $\beta$  (line 10). To populate the schedule appropriately, we move forward in  $\pi$  from  $e' = \pi[j]$  till  $(end, t_1) = \pi[j]$  in  $\pi$  (lines 12,13). Then we inspect the transactions  $t''$  appearing in  $\pi$  between  $\pi[j]$  (the end of  $t_1$ ) and  $\pi[k]$  (start of  $t_2$ ), to see if these can be retained before  $t_2$  in the schedule. **Create schedule for  $e'$ .** We create a schedule for  $e'$  by inspecting all transactions  $t''$  which appear between  $\pi[j] = (end, t_1)$  and  $\pi[k] = (begin, t_2)$  (while loop in line 14). We check whether

- (1)  $t''$  happens before  $t_2$  (line 16).
- (2)  $t_1$  does not happen before  $t''$ , and
- (3)  $t''$  does not overwrite reads made by  $t_1$  (line 18).

If (2) or (3) is violated (line 18), it means  $t_1$  happens before  $t''$  or,  $t''$  overwrites a read made by  $t_1$ . Then, we cannot choose  $t''$  in the schedule, and exit the function. If (1) is violated, then  $t''$

does not happen before  $t_2$ , and we need not bother including  $t''$  in the schedule. Hence, we move forward beyond  $t''$  (lines 31-33). If (1),(2),(3) all hold good, then we proceed to include  $t''$  in the schedule (lines 23-26). When we reach  $(end, t_2)$ , the loop ends. Then we append the constructed schedule  $\beta$  with events from  $t_2$ , followed by events from  $t_1$  till  $(read, t_1, t_2)$ . This schedule is added to  $schedules(e')$  if it already does not exist.

**Algorithm 3 RunSchedule.** *RunSchedule* is called when the recursive call of *ExploreTraces* returns at line 24 in Algorithm 1, at the end of a read event  $e' = (read, t, t')$  in transaction  $t$ . Let the observation sequence be  $\pi = \pi'.(begin, t) \dots (read, t, t')$ , where  $\pi'$  denotes the earlier transactions which have been executed. Assuming the configuration  $\sigma$  and trace  $\tau$  before adding the *rf* edge from  $t$  to  $t'$ , *RunSchedule* is called on  $\sigma, \tau, \pi'$  and a schedule  $\beta \in Schedules(e')$  (line 26, Algorithm 1). Note that  $\beta$  ends with the suffix  $(begin, t) \dots (read, t, t')$ . All read events  $e'$  having *Swappable*( $e'$ ) as TRUE in  $\beta$  are made FALSE. This is an optimization step, to rule out redundant schedules corresponding to the read events in  $\beta$ . We obtain the observation sequence  $\pi' \cdot \beta$  by appending transactions from  $\beta$  one at a time to  $\pi'$ . The trace  $\tau$  is updated to trace  $\tau'$  obtained on executing  $\beta$ . At the end, we invoke *ExploreTraces* on  $\tau', \pi' \cdot \beta$ .

### 6.1 An Illustrating Example

We illustrate the DPOR algorithm on Figure 12. We have presented all the traces as well as the recursion tree in Figure 13. The nodes  $n_0 \dots n_{35}$  represent recursive calls to *ExploreTraces* and *RunSchedule*.  $n_0$  is the first call to *ExploreTraces* with an empty trace and observation sequence.

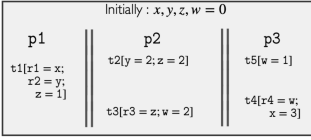

Fig. 12. Example for DPOR

From  $n_0$ , consider the case when *ExploreTraces* selects  $t1$ , making recursive calls to itself after each instruction in  $t1$ . The two reads of  $t1$  each have two sources to read from,  $init_x$  or  $t4$ , and  $init_y$  or  $t2$ . The reads from  $t4, t2$  will be scheduled later, by a call to *CreateSchedule*, as indicated by the orange arrows. The last call to *ExploreTraces* in  $t1$  is made at  $(end, t1)$  reaching node  $n_1$ . Next, *ExploreTraces* selects  $t2$ , and the last recursive call in  $t2$  leads to

node  $n_5$ , where  $t3$  is selected. The read in  $t3$  has two choices to read from :  $t1$  and  $t2$ , and makes two recursive calls after each choice. The respective last recursive calls to *ExploreTraces* leading to  $n_9, n_{10}$ .  $t5$  is selected next, leading to nodes  $n_{16}$  and  $n_{17}$ . Finally,  $t4$  is chosen.  $t4$  has two sources to read from, namely,  $t5$  and  $t3$ , leading to nodes  $n_{23}$  to  $n_{26}$ . This gives traces  $\tau_1, \dots, \tau_4$ , and respective observation sequences. For eg., the observation sequence for  $\tau_3$  is  $(begin, t1), (read, t1, init_x), (read, t1, init_y), (write, t1), (end, t1), (begin, t2), \dots, (end, t2), (begin, t3), (read, t3, t1), (write, t3), (end, t3), (begin, t5), \dots, (end, t5), (begin, t4), (read, t4, t5), (write, t4), (end, t4)$ . The recursive call to *ExploreTraces* from  $n_{23}, n_{24}, n_{25}, n_{26}$  returns as there are no more transactions, and *CreateSchedule* is called from these since  $t4$  has write instructions.

From  $n_{23}$ , the recursive call of *ExploreTraces* returns to the point after  $(end, t4)$ , where *CreateSchedule* is invoked. We traverse back in the observation sequence till  $(begin, t4)$  (line 2 of *CreateSchedule*). We keep moving back till obtaining the read event  $e'$  of  $r1$  in  $t1$ , for which *localread*( $e'$ ) has been set to FALSE and *swappable*( $e'$ ) set to TRUE in *ExploreTraces*. We check if  $t1$  happens before  $t4$ , which it does not and also check that  $t4$  does not overwrite any prior reads of  $t1$  and check absence of *co*-cycles. Thus,  $t4$  and  $t1$  can be swapped. The schedule  $\beta_1$  is initialized. We then check whether the transactions  $t2, t3, t5$  which happen between  $(end, t1)$  and  $(begin, t4)$  should be retained before  $t4$  in the schedule for  $e'$ . Since  $\neg t2[po \cup rf]^+ t4, \neg t3[po \cup rf]^+ t4$ , the schedule need not contain  $t2, t3$ , and we skip over them. However,  $t5[po \cup rf]^+ t4$  and must be retained

in the schedule. So we obtain  $\beta_1 = (\text{begin}, t5) \dots (\text{end}, t5) \cdot (\text{begin}, t4) \dots (\text{end}, t4)(\text{begin}, t1) \dots (\text{read}, t1, t4)$  in  $Schedules(e')$ . After this, the call from *CreateSchedule* returns, and we trace back to  $n_{16}$  and change the source (from the readable set) for  $r_4$ , so  $r_4 = 2$  and we get the new trace  $\tau_2$ .

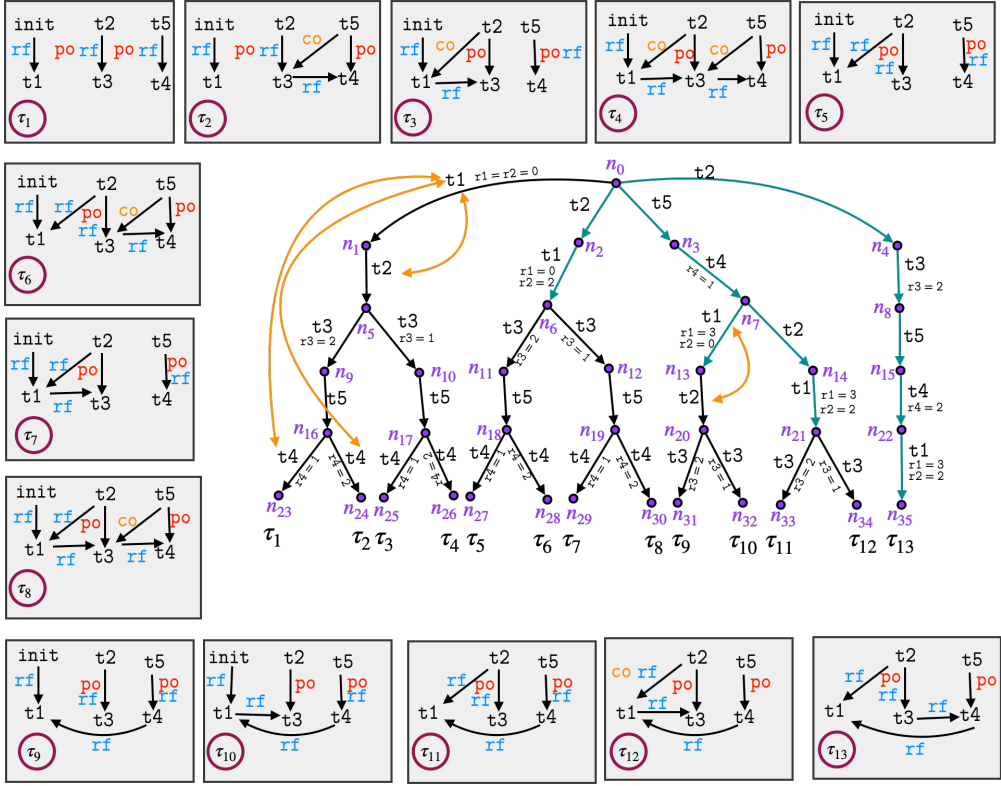

Fig. 13. Traces and recursion tree for the program in Figure 12. The nodes  $n_0$  to  $n_{35}$  represent recursive calls to Algorithm 1. The black edges come from Algorithm 1, green edges represent Algorithm 3 running a schedule created by a call to Algorithm 2. The orange lines denote the pairs of writes and reads, resulting in schedules. The edges are decorated with the transactions executed, and register values read.

The call to *ExploreTraces* at node  $n_{24}$  returns to the point after  $(\text{end}, t4)$ , after which *CreateSchedule* is invoked. The corresponding read event is again  $e'$  of  $r_1$  in  $t_1$ . As seen above, we check whether the transactions  $t_2, t_3, t_5$  which happen between  $(\text{end}, t1)$  and  $(\text{begin}, t4)$  should be retained before  $t_4$  in the schedule for  $e'$ . Indeed,  $t_3[po \cup rf]^+ t_4, t_2[po \cup rf]^+ t_3, t_5[po] t_4$ . Hence we obtain another schedule  $\beta_2 = (\text{begin}, t2) \dots (\text{end}, t2) (\text{begin}, t3) \dots (\text{end}, t3) (\text{begin}, t5) \dots (\text{end}, t5) (\text{begin}, t4) \dots (\text{end}, t4) (\text{begin}, t1)$  in  $Schedules(e')$ . Then we backtrack to  $n_{16}$  and call *CreateSchedule* at  $(\text{end}, t5)$  which returns an empty schedule since there are no corresponding read events. Then we backtrack to node  $n_9$  and then to  $n_5$  till we can change the source for  $r_3$ , which reads from  $t_1$ . We continue exploring traces with *ExploreTraces* and obtain  $\tau_3, \tau_4$ . We invoke *CreateSchedule* from nodes  $n_{25}$  and  $n_{26}$ , however these do not add any more schedules to  $e'$ , since they are equivalent to what has been added already in  $Schedules(e')$ . From  $n_{25}$ , we backtrack and reach node  $n_5$  and invoke *CreateSchedule* at  $(\text{end}, t2)$  which creates a schedule  $\gamma_1$  corresponding to the read event  $e''$  of  $r_2$  in  $t_1$ .  $\gamma_1 = (\text{begin}, t2) \dots (\text{end}, t2) (\text{begin}, t1) (\text{read}, t1, \text{init}_x) (\text{read}, t1, t2)$  is added to  $Schedules(e'')$ .

We then backtrack till the point  $r2 = 0$  and find that  $Schedules(e'')$  is nonempty. *RunSchedule* runs the schedule  $\gamma_1$  (shown in green edges  $n_0 - n_2 - n_6$ ), followed by recursive calls to *ExploreTraces*, resulting in traces  $\tau_5, \tau_6, \tau_7, \tau_8$ . At node  $n_{30}$  on return from *ExploreTraces*, we backtrack till the point  $r1 = 0$  and find two schedules  $\beta_1, \beta_2$  in  $Schedules(e')$ . We invoke *RunSchedule* first for  $\beta_1$ , obtaining traces  $\tau_9, \tau_{10}$  ending at nodes  $n_{31}, n_{32}$ . At nodes  $n_{31}, n_{32}$ , we invoke *CreateSchedule* at  $(end, t3)$  but these will not generate any schedules for the read  $r4$  in  $t4$  since *swappable* is FALSE for this read event. Note that  $t4[rf]t3$  (along with  $t1[rf]t4, t1[rf]t2$ ) is covered by trace  $\tau_{13}$ ; thus, we optimize on redundant traces by keeping *swappable* FALSE. We backtrack till  $(end, t2)$  at  $n_{20}$  and invoke *CreateSchedule* corresponding to the write in  $t2$ , which can be a source for the read in  $t1$ . This adds the schedule  $\gamma_2 = (begin, t2) \dots (end, t2) (begin, t1)(read, t1, t4)(read, t1, t2)$  to  $Schedules(e'')$ . On returning from this call, we backtrack till the read  $e''$  of  $r2 = 0$  in  $t1$  and invoke *RunSchedule* at node  $n_7$  (the green edges  $n_7 - n_{14} - n_{21}$ ) for  $\gamma_2$ . After *RunSchedule* finishes  $n_{21}$ , we invoke *ExploreTraces* and obtain traces  $\tau_{11}, \tau_{12}$ .

At node  $n_{34}$  on return from *ExploreTraces*, we backtrack till the read event  $e'$  of  $r1$  in  $t1$  and invoke *RunSchedule* on the remaining schedule  $\beta_2$ , obtaining trace  $\tau_{13}$ .

## 6.2 Complexity, Soundness and Completeness of the DPOR algorithm

Our DPOR algorithm spends polynomial time per explored trace : (1) each schedule has length bounded by the program length, (2) each schedule we generate corresponds to a partially good, weak trace which has not been generated before, and is added to the set of schedules only if it has not been added. Checking if a new schedule is equal to an existing one can be done in polynomial time : arrange all created schedules as a tree, and, compare from the root, with respect to the new schedule, going over the *rf* relations.

**THEOREM 6.1.** *The CCv DPOR algorithm is sound, complete and optimal.*

**Soundness.** The algorithm is sound in the sense that, if we initiate Algorithm 1 from  $(\sigma, \tau_0, \epsilon)$ , then, all explored traces  $\tau$  are s.t.  $\tau \in [[\sigma]]_{CCv}^{full}$ . This follows from the fact that the exploration uses the  $\rightarrow_{full}$  relation (lines 6, 23 in Algorithm 1 and line 4 in Algorithm 3).

**Optimality.** The algorithm is optimal in the sense that, for any two different recursive calls to Algorithm 1 with arguments  $(\sigma_1, \tau_1, \pi_1)$  and  $(\sigma_2, \tau_2, \pi_2)$ , if  $\sigma_1, \sigma_2$  are not terminal, then  $weak(\tau_1) \neq weak(\tau_2)$ . This follows from (i) each time we run the for loop in line 23, the read event will read from a different source, (ii) in each schedule  $\beta \in schedules(e)$  in line 25 of Algorithm 1, the event  $e$  reads from a transaction  $t$  which is different from all transactions it reads from in lines 16, 19, (iii) Any two schedules added to  $schedules(e)$  at line 33 of Algorithm 2 will have a read event reading from different transactions.

**Completeness.** The algorithm is complete in the sense that for any input configuration  $\sigma$ , it produces all weak traces corresponding to terminating runs from  $\sigma$ . That is, for any  $\sigma$ , terminal run  $\rho \in ExecFrom(\sigma)$ , and total trace  $\tau$  s.t.  $\tau \models \rho$ ,  $ExploreTraces(\sigma, \tau_0, \epsilon)$  produces a recursive call  $ExploreTraces(\sigma', \tau', \pi)$  for some terminal  $\sigma', \tau'$  and  $\pi$  with  $weak(\tau') = weak(\tau)$ .

## 7 EXPERIMENTS

We have implemented our CCv, CC-DPOR algorithms as a tool TRANCHECKER by extending NID-HUGG [Abdulla et al. 2015]. TRANCHECKER works at LLVM IR level and accepts a C language program as input. It can detect run-time errors, user-provided assertion violations by analyzing the generated weak traces. TRANCHECKER explores each trace from the set of weak traces by controlling the exploration of the input program. We conduct all experiments on a Ubuntu 20.04.3 LTS with Intel Core i7-1165G7 and 16 GB RAM. We evaluate TRANCHECKER on three sets of benchmarks, as seen in Sections 7.1, 7.2 and 7.3.

Table 1. TRANCHECKER on litmus tests.

Expected	Observed	Count
Allow	Allow	94
Forbid	Forbid	476
Forbid	Allow	194
Allow	Forbid	37 [36+1]

Table 2. Evaluating TRANCHECKER on Applications.

Applications	Transactions	Time
Vote [Difallah et al. 2013]	3	0.11s
Twitter [Holt et al. 2016]	4	0.09s
FusionTicket [Holt et al. 2016]	8	0.51s
Betting [Beillahi et al. 2021a]	5	0.20s
Auction [Nair et al. 2020]	8	0.11s
Auction-2 [Nair et al. 2020]	8	0.27s
Whatsapp	3	0.12s

Table 3. Evaluating behaviour of TRANCHECKER on classical benchmarks

Program	CCv	CC
Causality Violation [Bernardi and Gotsman 2016]	SAFE	SAFE
Causal Violation [Biswas and Enea 2019]	SAFE	SAFE
Co-Read Atomicity	SAFE	UNSAFE
Delivery Order [Beillahi et al. 2021b]	UNSAFE	UNSAFE
Load Buffer	SAFE	SAFE
Long Fork [Bernardi and Gotsman 2016]	UNSAFE	UNSAFE
Lost Update [Bernardi and Gotsman 2016]	UNSAFE	UNSAFE
Lost Update-2 [Bernardi and Gotsman 2016]	UNSAFE	UNSAFE
Modification Order	SAFE	UNSAFE
Message Passing [Beillahi et al. 2021a]	SAFE	SAFE
Conflict violation [Biswas and Enea 2019]	UNSAFE	UNSAFE
Serializability violation [Biswas and Enea 2019]	UNSAFE	UNSAFE
Read Atomicity [Biswas and Enea 2019]	SAFE	SAFE
Read Committed [Biswas and Enea 2019]	UNSAFE	UNSAFE
Repeated Read [Biswas and Enea 2019]	SAFE	SAFE
Repeated Read-2 [Biswas and Enea 2019]	SAFE	UNSAFE
Store Buffer	UNSAFE	UNSAFE
Write-po-Read	SAFE	SAFE
Write-po-Read-2	SAFE	SAFE
Write Skew [Bernardi and Gotsman 2016]	UNSAFE	UNSAFE

## 7.1 Evaluation on Litmus Tests

The first set of experiments (Table 1) includes litmus tests from [Alglave et al. 2014]. These litmus tests [Alglave et al. 2014] are non-transactional programs and are used as a sanity check in tool development. Out of a total of 4000 litmus tests, we selected all litmus tests free of locks and fences, and where assertions were on local registers. There are 800 such examples. Litmus tests which had RMW primitives were replaced by a pair of loads and stores and treated as a single transaction. We instrument these litmus tests into transactional programs by grouping the instructions in each process arbitrarily. Given the small number of instructions per process in the litmus tests of [Alglave et al. 2014], we group all instructions in a process as a single transaction. In these litmus tests, the processes execute concurrently, and we check if an assertion is violated or not. Table 1 describes the outcomes observed on the litmus tests. The column “Expected” represents the outcomes using Herd-RA [Abdulla et al. 2018] (i.e, the Herd tool together with the set of RA-axioms provided in [Lahav et al. 2016]). An outcome *Allow* in Table 1 means that the program allows an execution that violates the assertion; otherwise the outcome is *Forbid*. The first and second rows have litmus tests where the allowed and forbidden behaviours match in Herd-RA



p1	p2	p3	p4
t1[x=1]	t3[y=3]	t5[x1=x]//4	t7[r3=y]//2
t2[y=2]	t4[x=4]	t6[x2=x]//1	t8[r4=y]//3

Fig. 14. Program where CCv does not have the violating execution of Herd-RA

Herd-RA, but is forbidden under CCv, CC. We probe further if splitting the instructions into more transactions will witness the assertion violation as expected. Doing so, 36 out of the 37 programs witnessed the assertion violation as expected in Herd-RA. However, one program (Figure 14) under CCv still forbid the assertion violation irrespective of how the instructions were grouped. This was because executions which were violating the assertion in Herd-RA were not CCv consistent. Under CC, after splitting transactions we could witness the violation for this program, as expected, since the CC semantics is weaker than CCv.

as well as for TRANCHECKER, for both CCv and CC. The 3rd row consists of programs where there is no assertion violation in Herd-RA, but, under CCv and CC the violation crops up. CCv and CC allows these assertion violations. In the case of CC, this follows from the weaker semantics, while for CCv, this is due to the replacement of RMW instructions with transactions (as mentioned above). In the last row we see 37 programs where an assertion violation is expected in

## 7.2 Evaluation on Classical Transactional Anomalies

The second set (Table 3) consists of classical benchmark examples from databases on well-known transaction related anomalies [Bernardi and Gotsman 2016], [Biswas and Enea 2019], [Beillahi et al. 2021b] and [Beillahi et al. 2021a]. We consider twenty examples based on database anomalies. While most of them are taken from cited sources, the ones without a citation in Table 3 are created by us, and can be seen in the supplementary material.

For each of these examples, we have made three versions by parameterizing on the number of processes and transactions. In version 1, we have four processes per program and two transactions per process. Version 2 is obtained allowing each process to have four transactions. Version 3 expands version 2 by allowing each program to have five processes. Versions 2,3 serve as a stress test for TRANCHECKER as increasing the number of transactions and processes increases the number of executions to be explored as well as the number of consistent traces. TRANCHECKER took less than a second to finish running all version 1 programs, about 15 seconds to finish running all version 2 programs and about 200 seconds to finish running all version 3 programs. All programs in Table 3 are classified as SAFE or UNSAFE, depending on whether or not they have executions violating the assertion. Since programs under CC semantics may exhibit more behaviours than CCv, Co-Read Atomicity, Modification Order, and Repeated Read-2 are UNSAFE under CC semantics while they are SAFE under the CCv semantics.

## 7.3 Evaluation on some Applications

The third set (Table 2) of benchmarks consists of transactional programs inspired from six distributed systems and database applications [Difallah et al. 2013], [Holt et al. 2016], [Beillahi et al. 2021b], [Nair et al. 2020]. For each application, TRANCHECKER verifies the assertions given in these papers on all possible executions. For instance, Auction [Nair et al. 2020] is a buggy application where the highest bid may not win, while Auction-2 [Nair et al. 2020] is the non buggy version where only the highest bid will win. TRANCHECKER detected the execution leading to the bug in Auction [Nair et al. 2020], and also verified that in all executions of Auction-2, the highest bid wins. WhatsApp is a synthetic application created by us, where we verify that a new user can be added to a group only in one execution.

## 8 CONCLUSION

We have presented a DPOR algorithm to verify programs running on causally consistent semantics. We have developed an axiomatic model for such programs and presented an efficient procedure that allows identifying the set of write operations that we can read in a given configuration without compromising causal consistency. While the current paper is a step toward developing a general DPOR framework that can handle transactions, several exciting challenges lie ahead. One direction for future work is to consider other semantics such as serializability. We have to extend the fulfillment procedure to have an NP-complete complexity rather than polynomial complexity since we would need techniques similar to those developed in [Abdulla et al. 2019]. Another relevant challenge is to allow abortion and commitment policies, in which conflicting transactions are rolled back. We would need methods that allow optimality while at the same avoiding deadlocks in the executions of the DPOR algorithm [Abdulla et al. 2017].

## REFERENCES

- Parosh Abdulla, Stavros Aronis, Bengt Jonsson, and Konstantinos Sagonas. 2014. Optimal Dynamic Partial Order Reduction. In *Proceedings of the 41st ACM SIGPLAN-SIGACT Symposium on Principles of Programming Languages (POPL '14)*. Association for Computing Machinery, New York, NY, USA, 373–384. <https://doi.org/10.1145/2535838.2535845>
- Parosh Aziz Abdulla, Stavros Aronis, Mohamed Faouzi Atig, Bengt Jonsson, Carl Leonardsson, and Konstantinos Sagonas. 2015. Stateless Model Checking for TSO and PSO. In *Tools and Algorithms for the Construction and Analysis of Systems*, Christel Baier and Cesare Tinelli (Eds.). Springer Berlin Heidelberg, Berlin, Heidelberg, 353–367.
- Parosh Aziz Abdulla, Stavros Aronis, Bengt Jonsson, and Konstantinos Sagonas. 2017. Source Sets: A Foundation for Optimal Dynamic Partial Order Reduction. *J. ACM* 64, 4 (2017), 25:1–25:49. <https://doi.org/10.1145/3073408>
- Parosh Aziz Abdulla, Mohamed Faouzi Atig, Bengt Jonsson, Magnus Lång, Tuan Phong Ngo, and Konstantinos Sagonas. 2019. Optimal Stateless Model Checking for Reads-from Equivalence under Sequential Consistency. *Proc. ACM Program. Lang.* 3, OOPSLA, Article 150 (Oct. 2019), 29 pages. <https://doi.org/10.1145/3360576>
- Parosh Aziz Abdulla, Mohamed Faouzi Atig, Bengt Jonsson, and Tuan Phong Ngo. 2018. Optimal Stateless Model Checking under the Release-Acquire Semantics. *Proc. ACM Program. Lang.* 2, OOPSLA, Article 135 (Oct. 2018), 29 pages. <https://doi.org/10.1145/3276505>
- Mustaque Ahamad, Gil Neiger, James E. Burns, Prince Kohli, and Phillip W. Hutto. 1995. Causal Memory: Definitions, Implementation, and Programming. *Distributed Comput.* 9, 1 (1995), 37–49. <https://doi.org/10.1007/BF01784241>
- Jade Alglave, Luc Maranget, and Michael Tautschnig. 2014. Herding Cats: Modelling, Simulation, Testing, and Data Mining for Weak Memory. *ACM Trans. Program. Lang. Syst.* 36, 2, Article 7 (jul 2014), 74 pages. <https://doi.org/10.1145/2627752>
- Sidi Mohamed Beillahi, Ahmed Bouajjani, and Constantin Enea. 2021a. Checking Robustness Between Weak Transactional Consistency Models. *Programming Languages and Systems* 12648 (2021), 87.
- Sidi Mohamed Beillahi, Ahmed Bouajjani, and Constantin Enea. 2021b. Robustness Against Transactional Causal Consistency. *Logical Methods in Computer Science* Volume 17, Issue 1 (Feb. 2021). [https://doi.org/10.23638/LMCS-17\(1:12\)2021](https://doi.org/10.23638/LMCS-17(1:12)2021)
- Giovanni Bernardi and Alexey Gotsman. 2016. Robustness against consistency models with atomic visibility. In *27th International Conference on Concurrency Theory (CONCUR 2016)*. Schloss Dagstuhl-Leibniz-Zentrum fuer Informatik.
- Ranadeep Biswas and Constantin Enea. 2019. On the Complexity of Checking Transactional Consistency. *Proc. ACM Program. Lang.* 3, OOPSLA, Article 165 (oct 2019), 28 pages. <https://doi.org/10.1145/3360591>
- Ahmed Bouajjani, Constantin Enea, Rachid Guerraoui, and Jad Hamza. 2017. On Verifying Causal Consistency. *SIGPLAN Not.* 52, 1 (Jan. 2017), 626–638. <https://doi.org/10.1145/3093333.3009888>
- Lucas Brutschy, Dimitar K. Dimitrov, Peter Müller, and Martin T. Vechev. 2017. Serializability for eventual consistency: criterion, analysis, and applications. In *Proceedings of the 44th ACM SIGPLAN Symposium on Principles of Programming Languages, POPL 2017, Paris, France, January 18-20, 2017*. 458–472. <https://doi.org/10.1145/3009837.3009895>
- Lucas Brutschy, Dimitar K. Dimitrov, Peter Müller, and Martin T. Vechev. 2018. Static serializability analysis for causal consistency, See [Foster and Grossman 2018], 90–104. <https://doi.org/10.1145/3192366.3192415>
- Sebastian Burckhardt. 2014. Principles of Eventual Consistency. *Found. Trends Program. Lang.* 1, 1-2 (2014), 1–150. <https://doi.org/10.1561/25000000011>
- Andrea Cerone and Alexey Gotsman. 2018. Analysing Snapshot Isolation. *J. ACM* 65, 2 (2018), 11:1–11:41. <https://doi.org/10.1145/3152396>
- Andrea Cerone, Alexey Gotsman, and Hongseok Yang. 2017. Algebraic Laws for Weak Consistency. *CoRR* abs/1702.06028 (2017). arXiv:1702.06028 <http://arxiv.org/abs/1702.06028>

- Marek Chalupa, Krishnendu Chatterjee, Andreas Pavlogiannis, Nishant Sinha, and Kapil Vaidya. 2017. Data-Centric Dynamic Partial Order Reduction. *Proc. ACM Program. Lang.* 2, POPL, Article 31 (dec 2017), 30 pages. <https://doi.org/10.1145/3158119>
- Nathan Chong, Tyler Sorensen, and John Wickerson. 2018. The semantics of transactions and weak memory in x86, Power, ARM, and C++. See [Foster and Grossman 2018], 211–225. <https://doi.org/10.1145/3192366.3192373>
- Maria Christakis, Alkis Gotovos, and Konstantinos Sagonas. 2013. Systematic Testing for Detecting Concurrency Errors in Erlang Programs. In *Sixth IEEE International Conference on Software Testing, Verification and Validation, ICST 2013, Luxembourg, Luxembourg, March 18-22, 2013*. IEEE Computer Society, 154–163. <https://doi.org/10.1109/ICST.2013.50>
- Edmund M. Clarke, Orna Grumberg, Marius Minea, and Doron A. Peled. 1999. State Space Reduction Using Partial Order Techniques. *Int. J. Softw. Tools Technol. Transf.* 2, 3 (1999), 279–287. <https://doi.org/10.1007/s100090050035>
- Thomas H. Cormen, Charles E. Leiserson, Ronald L. Rivest, and Clifford Stein. 2009. *Introduction to Algorithms, Third Edition* (3rd ed.). The MIT Press.
- Djellel Eddine Difallah, Andrew Pavlo, Carlo Curino, and Philippe Cudre-Mauroux. 2013. OLTP-Bench: An Extensible Testbed for Benchmarking Relational Databases. *Proc. VLDB Endow.* 7, 4 (dec 2013), 277–288. <https://doi.org/10.14778/2732240.2732246>
- Michael J. Fischer, Nancy A. Lynch, and Mike Paterson. 1985. Impossibility of Distributed Consensus with One Faulty Process. *J. ACM* 32, 2 (1985), 374–382. <https://doi.org/10.1145/3149.214121>
- Jeffrey S. Foster and Dan Grossman (Eds.). 2018. *Proceedings of the 39th ACM SIGPLAN Conference on Programming Language Design and Implementation, PLDI 2018, Philadelphia, PA, USA, June 18-22, 2018*. ACM. <https://doi.org/10.1145/3192366>
- Seth Gilbert and Nancy A. Lynch. 2002. Brewer’s conjecture and the feasibility of consistent, available, partition-tolerant web services. *SIGACT News* 33, 2 (2002), 51–59. <https://doi.org/10.1145/564585.564601>
- Patrice Godefroid. 1996. *Partial-Order Methods for the Verification of Concurrent Systems - An Approach to the State-Explosion Problem*. Lecture Notes in Computer Science, Vol. 1032. Springer. <https://doi.org/10.1007/3-540-60761-7>
- Patrice Godefroid. 1997. Model Checking for Programming Languages Using VeriSoft. In *Proceedings of the 24th ACM SIGPLAN-SIGACT Symposium on Principles of Programming Languages (POPL ’97)*. Association for Computing Machinery, New York, NY, USA, 174–186. <https://doi.org/10.1145/263699.263717>
- Patrice Godefroid. 2005. Software Model Checking: The VeriSoft Approach. *Form. Methods Syst. Des.* 26, 2 (March 2005), 77–101. <https://doi.org/10.1007/s10703-005-1489-x>
- Tim Harris, James R. Larus, and Ravi Rajwar. 2010. *Transactional Memory, 2nd edition*. Morgan & Claypool Publishers. <https://doi.org/10.2200/S00272ED1V01Y201006CAC011>
- Maurice Herlihy and J. Eliot B. Moss. 1993. Transactional Memory: Architectural Support for Lock-Free Data Structures. In *Proceedings of the 20th Annual International Symposium on Computer Architecture, San Diego, CA, USA, May 1993*, Alan Jay Smith (Ed.). ACM, 289–300. <https://doi.org/10.1145/165123.165164>
- Brandon Holt, James Bornholt, Irene Zhang, Dan Ports, Mark Oskin, and Luis Ceze. 2016. Disciplined Inconsistency with Consistency Types. In *Proceedings of the Seventh ACM Symposium on Cloud Computing (SoCC ’16)*. Association for Computing Machinery, New York, NY, USA, 279–293. <https://doi.org/10.1145/2987550.2987559>
- Michalis Kokologiannakis, Ori Lahav, Konstantinos Sagonas, and Viktor Vafeiadis. 2018. Effective stateless model checking for C/C++ concurrency. *Proc. ACM Program. Lang.* 2, POPL (2018), 17:1–17:32. <https://doi.org/10.1145/3158105>
- Michalis Kokologiannakis, Iason Marmanis, Vladimir Gladstein, and Viktor Vafeiadis. 2022. Truly stateless, optimal dynamic partial order reduction. *Proc. ACM Program. Lang.* 6, POPL (2022), 1–28. <https://doi.org/10.1145/3498711>
- Michalis Kokologiannakis and Viktor Vafeiadis. 2021. GenMC: A Model Checker for Weak Memory Models. In *Computer Aided Verification*, Alexandra Silva and K. Rustan M. Leino (Eds.). Springer International Publishing, Cham, 427–440.
- Ori Lahav. 2019. Verification under causally consistent shared memory. *ACM SIGLOG News* 6, 2 (2019), 43–56. <https://doi.org/10.1145/3326938.3326942>
- Ori Lahav, Nick Giannarakis, and Viktor Vafeiadis. 2016. Taming Release-Acquire Consistency. In *Proceedings of the 43rd Annual ACM SIGPLAN-SIGACT Symposium on Principles of Programming Languages (POPL ’16)*. Association for Computing Machinery, New York, NY, USA, 649–662. <https://doi.org/10.1145/2837614.2837643>
- Leslie Lamport. 1978. Time, Clocks, and the Ordering of Events in a Distributed System. *Commun. ACM* 21, 7 (1978), 558–565. <https://doi.org/10.1145/359545.359563>
- Leslie Lamport. 1979. How to Make a Multiprocessor Computer That Correctly Executes Multiprocess Programs. *IEEE Trans. Computers* 28, 9 (1979), 690–691. <https://doi.org/10.1109/TC.1979.1675439>
- A Mazurkiewicz. 1987. Trace Theory. In *Advances in Petri Nets 1986, Part II on Petri Nets - Applications and Relationships to Other Models of Concurrency*. Springer-Verlag, Berlin, Heidelberg, 279–324.
- Kathryn S. McKinley and Kathleen Fisher (Eds.). 2019. *Proceedings of the 40th ACM SIGPLAN Conference on Programming Language Design and Implementation, PLDI 2019, Phoenix, AZ, USA, June 22-26, 2019*. ACM. <https://doi.org/10.1145/3314221>
- Madanlal Musuvathi, Shaz Qadeer, Thomas Ball, Gérard Basler, Piramanayagam Arumuga Nainar, and Iulian Neamtii. 2008. Finding and Reproducing Heisenbugs in Concurrent Programs. In *8th USENIX Symposium on Operating Systems Design and Implementation, OSDI 2008, December 8-10, 2008, San Diego, California, USA, Proceedings*, Richard Draves and Robbert

- van Renesse (Eds.). USENIX Association, 267–280. [http://www.usenix.org/events/osdi08/tech/full\\_papers/musuvathi/musuvathi.pdf](http://www.usenix.org/events/osdi08/tech/full_papers/musuvathi/musuvathi.pdf)
- Kartik Nagar and Suresh Jagannathan. 2018. Automated Detection of Serializability Violations Under Weak Consistency. In *29th International Conference on Concurrency Theory, CONCUR 2018, September 4-7, 2018, Beijing, China (LIPIcs)*, Sven Schewe and Lijun Zhang (Eds.), Vol. 118. Schloss Dagstuhl - Leibniz-Zentrum für Informatik, 41:1–41:18. <https://doi.org/10.4230/LIPIcs.CONCUR.2018.41>
- Sreeja S. Nair, Gustavo Petri, and Marc Shapiro. 2020. Proving the Safety of Highly-Available Distributed Objects. In *Programming Languages and Systems*, Peter Müller (Ed.). Springer International Publishing, Cham, 544–571.
- Brian Norris and Brian Demsky. 2016. A Practical Approach for Model Checking C/C++11 Code. *ACM Trans. Program. Lang. Syst.* 38, 3, Article 10 (May 2016), 51 pages. <https://doi.org/10.1145/2806886>
- Christos H. Papadimitriou. 1979. The serializability of concurrent database updates. *J. ACM* 26, 4 (1979), 631–653. <https://doi.org/10.1145/322154.322158>
- Matthieu Perrin, Achour Mostefaoui, and Claude Jard. 2016. Causal Consistency: Beyond Memory. *SIGPLAN Not.* 51, 8, Article 26 (feb 2016), 12 pages. <https://doi.org/10.1145/3016078.2851170>
- Azalea Raad, Ori Lahav, and Viktor Vafeiadis. 2018. On Parallel Snapshot Isolation and Release/Acquire Consistency. In *Programming Languages and Systems - 27th European Symposium on Programming, ESOP 2018, Held as Part of the European Joint Conferences on Theory and Practice of Software, ETAPS 2018, Thessaloniki, Greece, April 14-20, 2018, Proceedings (Lecture Notes in Computer Science)*, Amal Ahmed (Ed.), Vol. 10801. Springer, 940–967. [https://doi.org/10.1007/978-3-319-89884-1\\_33](https://doi.org/10.1007/978-3-319-89884-1_33)
- Azalea Raad, Ori Lahav, and Viktor Vafeiadis. 2019. On the Semantics of Snapshot Isolation. In *Verification, Model Checking, and Abstract Interpretation - 20th International Conference, VMCAI 2019, Cascais, Portugal, January 13-15, 2019, Proceedings (Lecture Notes in Computer Science)*, Constantin Enea and Ruzica Piskac (Eds.), Vol. 11388. Springer, 1–23. [https://doi.org/10.1007/978-3-030-11245-5\\_1](https://doi.org/10.1007/978-3-030-11245-5_1)
- Koushik Sen and Gul Agha. 2006. A Race-Detection and Flipping Algorithm for Automated Testing of Multi-Threaded Programs. In *Proceedings of the 2nd International Haifa Verification Conference on Hardware and Software, Verification and Testing (HVC'06)*. Springer-Verlag, Berlin, Heidelberg, 166–182.
- Dennis E. Shasha and Marc Snir. 1988. Efficient and Correct Execution of Parallel Programs that Share Memory. *ACM Trans. Program. Lang. Syst.* 10, 2 (1988), 282–312. <https://doi.org/10.1145/42190.42277>
- Alexandra Silva and K. Rustan M. Leino (Eds.). 2021. *Computer Aided Verification - 33rd International Conference, CAV 2021, Virtual Event, July 20-23, 2021, Proceedings, Part I*. Lecture Notes in Computer Science, Vol. 12759. Springer. <https://doi.org/10.1007/978-3-030-81685-8>
- Shale Xiong, Andrea Cerone, Azalea Raad, and Philippa Gardner. 2020. Data Consistency in Transactional Storage Systems: A Centralised Semantics. In *34th European Conference on Object-Oriented Programming, ECOOP 2020, November 15-17, 2020, Berlin, Germany (Virtual Conference) (LIPIcs)*, Robert Hirschfeld and Tobias Pape (Eds.), Vol. 166. Schloss Dagstuhl - Leibniz-Zentrum für Informatik, 21:1–21:31. <https://doi.org/10.4230/LIPIcs.ECOOP.2020.21>
- Naling Zhang, Markus Kusano, and Chao Wang. 2015. Dynamic Partial Order Reduction for Relaxed Memory Models. In *Proceedings of the 36th ACM SIGPLAN Conference on Programming Language Design and Implementation (PLDI '15)*. Association for Computing Machinery, New York, NY, USA, 250–259. <https://doi.org/10.1145/2737924.2737956>

## Appendix

The appendix contains the following sections.

- (1) Programs under  $CCv$ 
  - (a) The proof of Theorem 4.1 (Appendix A.1)
  - (b) The proof of Theorem 5.1 (Appendix B)
  - (c) Properties of the fulfilled semantics where we show that all generated traces are fulfilled and  $\models CCv$ . This proves Lemma 5.2 (Appendix C)
  - (d) The proof of Lemma 5.4 (Appendix D.1)
  - (e) A new incremental semantics that is equivalent to the total semantics (Appendix E). The incremental semantics defines the total traces in a step by step fashion, and simplifies the proof of Theorem 5.5.
  - (f) The proof of Theorem 5.5 (Appendix F)
  - (g) Proof of the completeness of the DPOR algorithm (Appendix G).
- (2) Programs under  $CC$ 
  - (a) Operational Semantics of  $CC$  from [Beillahi et al. 2021b] (Appendix H)
  - (b) Axiomatic Semantics for  $CC$  (Appendix I.1)
  - (c) Equivalence of  $CC$  axiomatic semantics with the operational semantics (Theorem I.5, Appendix I.1)
  - (d)  $CC$  Fulfilled Semantics (Appendix J)
  - (e) DPOR for  $CC$ , soundness, completeness and optimality (Appendix K)
- (3) Experimental Evaluation
  - (a) The litmus test where the assertion violating execution is not in  $CCv$ , for any grouping of instructions as transactions (Appendix L.1)
  - (b) Uncited programs used in Table 6 (Appendix L.2)
  - (c) Time taken by  $CCv$ ,  $CC$  for all 3 versions of the benchmarks used in Table 6 (Appendix L.4)

## Causal Convergence CCv

### A EQUIVALENCE OF THE AXIOMATIC AND OPERATIONAL SEMANTICS FOR CCv

#### A.1 Proof of Theorem 4.1

PROOF. First let us go from traces to legal execution summaries.

#### CCv-consistent Traces to Legal Execution Summaries

Consider a partial trace  $\tau = (\mathcal{T}, po, rf, -)$ . Assume that we can extend it to a total, CCv consistent trace  $\tau' = (\mathcal{T}, po, rf, co)$ . Given  $\tau'$ , we show that we can construct a  $\tau'$ -consistent, legal execution summary.

Assume that we have processes  $p_1, p_2, \dots, p_n$  in the concurrent program  $\mathcal{P}$  over the set of transactions  $\mathcal{T}$ . Define for each  $i$ ,

- Let  $A_i$  be the set of all transactions  $t \in \mathcal{T}$  issued in process  $p_i$ .
- Let  $A'_i = A_i \cup \mathcal{T}^w$ .  $A'_i$  contains all transactions issued in process  $p_i$ , as well as all transactions in  $\mathcal{T}$  having a write instruction.
- Define the relation  $<_i = ((hb \cap (A'_i \times A'_i)) \cup ((A_i \times (A'_i \setminus A_i)) \setminus hb^{-1}))$  where  $hb = (po \cup rf)^+$ . Relation  $<_i$  is a strict partial order.

$hb \cap (A'_i \times A'_i)$  is built on pairs of transactions  $(t, t')$  where  $t, t'$  are issued in  $p_i$ , representing  $po$ , as well as pairs  $(t, t')$  such that  $t$  is delivered to  $p_i$  and  $t'$  is issued in  $p_i$  after that, representing a  $rf$ . Likewise,  $((A_i \times (A'_i \setminus A_i)) \setminus hb^{-1})$  is built on pairs (i)  $(t, t')$  where  $t$  is issued in  $p_i$  and  $t'$  is delivered to  $p_i$  but not issued in  $p_i$ , such that  $(t', t) \notin hb$ .

Now define two sets of events  $T, T'$  as follows.

- Let  $T = \{\text{isu}(p_i, t) \mid 1 \leq i \leq n, t \in A_i\} \cup \{\text{del}(p_i, t) \mid 1 \leq i \leq n, t \in A'_i \setminus A_i\}$ . Thus,  $T$  consists of all transactions  $t$  issued in process  $p_i$ , or those transactions  $t$  delivered to process  $p_i$  (but not issued in  $p_i$ ).
- Let  $T' = \{\text{isu}(p_i, t) \mid 1 \leq i \leq n, t \in A_i \cap \mathcal{T}^w\}$ .  $T'$  consists of all transactions issued in process  $p_i$  which also have a write instruction.

We define the following relations on  $T, T'$ :

1.  $B_1 = \{\langle x(p_i, t), y(p_i, t') \rangle \in T \times T \mid x, y \in \{\text{isu}, \text{del}\} \text{ and } t <_i t'\}$ .  $B_1$  relates issue and delivery events in the **same** process  $p_i$ .  $B_1$  has pairs  $(\text{isu}(p_i, t), \text{isu}(p_i, t'))$  as well as  $(\text{del}(p_i, t), \text{isu}(p_i, t'))$  covering  $po \cup rf$  relations in each  $p_i$ . In addition,  $B_1$  also has the pairs  $(\text{del}(p_i, t), \text{del}(p_i, t'))$  as well as  $(\text{isu}(p_i, t), \text{del}(p_i, t'))$ . By definition of  $po \cup rf$  and  $<_i$ ,  $B_1$  is irreflexive (or acyclic).
2.  $B_2 = \{\langle \text{isu}(p_i, t), \text{del}(p_j, t) \rangle \in T' \times T\}$ .  $B_2$  relates the issue  $\text{isu}(p_i, t)$  of each transaction  $t$  in process  $p_i$  to its corresponding delivery  $\text{del}(p_j, t)$  in some process  $p_j$ . Clearly,  $B_2$  is also irreflexive.
3.  $B_3 = \{\langle \text{isu}(p_i, t), \text{isu}(p_j, t') \rangle \in T' \times T' \mid t [co] t'\}$ .  $B_3$  models the  $[co]$  relation, and is a total irreflexive order.

Indeed  $B_1 \cup B_2 \cup B_3$  is irreflexive. We build an execution summary using  $(B_1 \cup B_2 \cup B_3)$ , and the relation  $<$  induced by  $B_1, B_2, B_3$ . The events in the execution summary are obviously,  $Ev = \{\text{isu}(p, t), \text{del}(p, t') \mid t, t' \in \mathcal{T} \text{ and } p \in \mathbb{P}\}$ , and the ordering  $<$  is defined as  $(a, b) \in (B_1 \cup B_2 \cup B_3)^+ \Rightarrow a < b$ .

*A.1.1 < is a total order.* : To show that  $(Ev, <)$  is a legal execution summary, one of the things to show is that  $<$  is a total order on the events  $Ev$ . To this end, we show that  $(B_1 \cup B_2 \cup B_3)^+$  is irreflexive.

LEMMA A.1. *If  $\langle x(p_i, t_1), \text{isu}(p_j, t_2) \rangle \in (B_1 \cup B_2)^+$  then  $t_1 [po \cup rf]^+ t_2$ .*



PROOF. We prove this using induction. If  $(x(p_i, t_1), \text{isu}(p_j, t_2)) \in (B_1 \cup B_2)^+$ , then there is a sequence  $x_1(p_{i_1}, t_{j_1}) < x_2(p_{i_2}, t_{j_2}) < \dots < x_{n-1}(p_{i_{n-1}}, t_{j_{n-1}}) < x_n(p_{i_n}, t_{j_n})$ , where  $x_1(p_{i_1}, t_{j_1}) = x(p_i, t_1)$  and  $x_n(p_{i_n}, t_{j_n}) = \text{isu}(p_j, t_2)$ .

**Base Cases.** The base cases are (i)  $\langle x(p_1, t_1), \text{isu}(p_2, t_2) \rangle \in B_1$ , this case is trivial. (ii)  $\langle x_1(p_1, t_1), x_2(p_2, t_2) \rangle \in (B_1 \cup B_2)$  and  $\langle x_2(p_2, t_2), \text{isu}(p_3, t_3) \rangle \in (B_1 \cup B_2)$ . For (ii) we consider the following:

- (1)  $\langle x_1(p_1, t_1), x_2(p_2, t_2) \rangle \in B_1$  and  $\langle x_2(p_2, t_2), \text{isu}(p_3, t_3) \rangle \in B_1$ . It follows that  $p_1 = p_2 = p_3$ . Hence we have  $t_1 [po \cup rf]^+ t_3$ .
- (2)  $\langle x_1(p_1, t_1), x_2(p_2, t_2) \rangle \in B_2$  and  $\langle x_2(p_2, t_2), \text{isu}(p_3, t_3) \rangle \in B_1$ .  
 $\langle x_1(p_1, t_1), x_2(p_2, t_2) \rangle \in B_2$  implies that  $t_1 = t_2$  and  $x_2$  is del event. Since  $\langle x_2(p_2, t_2), \text{isu}(p_3, t_3) \rangle \in B_1$  we have  $p_2 = p_3$  and  $t_2 [po \cup rf]^+ t_3$ . Hence we have  $t_1 [po \cup rf]^+ t_3$ .

**Inductive Step.** Assume the result for all sequences of length  $\leq n-2$ , that is, whenever there is a sequence  $x_1(p_{i_1}, t_{j_1}) < x_2(p_{i_2}, t_{j_2}) < \dots < x_{n-2}(p_{i_{n-2}}, t_{j_{n-2}})$  with  $x_{n-2}(p_{i_{n-2}}, t_{j_{n-2}}) = \text{isu}(p_{i_{n-2}}, t_{j_{n-2}})$ , we have  $t_{j_1} [po \cup rf]^+ t_{j_{n-2}}$ .

Consider a sequence of length  $n$ . Let  $\langle x_{n-2}(p_{i_{n-2}}, t_{j_{n-2}}), x_{n-1}(p_{i_{n-1}}, t_{j_{n-1}}) \rangle \in (B_1 \cup B_2)$  and  $\langle x_{n-1}(p_{i_{n-1}}, t_{j_{n-1}}), x_n(p_{i_n}, t_{j_n}) \rangle \in (B_1 \cup B_2)$ , where  $x_n(p_{i_n}, t_{j_n}) = \text{isu}(p_j, t_2)$ . Here again we have two cases:

- (1)  $\langle x_{n-2}(p_{i_{n-2}}, t_{j_{n-2}}), x_{n-1}(p_{i_{n-1}}, t_{j_{n-1}}) \rangle, \langle x_{n-1}(p_{i_{n-1}}, t_{j_{n-1}}), x_n(p_{i_n}, t_{j_n}) \rangle \in B_1$ . It follows that  $p_{i_{n-2}} = p_{i_{n-1}} = p_{i_n} = p_j$ . Hence we have  $t_{j_{n-2}} [po \cup rf]^+ t_{j_n}$ . From the inductive hypothesis we have  $t_1 [po \cup rf]^+ t_{j_{n-2}}$ . Hence we have  $t_1 [po \cup rf]^+ t_{j_n}$ , i.e.  $t_1 [po \cup rf]^+ t_2$ .
- (2) Consider the case when  $\langle x_{n-2}(p_{i_{n-2}}, t_{j_{n-2}}), x_{n-1}(p_{i_{n-1}}, t_{j_{n-1}}) \rangle \in B_2$ , and  $\langle x_{n-1}(p_{i_{n-1}}, t_{j_{n-1}}), x_n(p_{i_n}, t_{j_n}) \rangle \in B_1$ .  
 Since  $\langle x_{n-2}(p_{i_{n-2}}, t_{j_{n-2}}), x_{n-1}(p_{i_{n-1}}, t_{j_{n-1}}) \rangle \in B_2$ , it follows that  $x_{n-1}$  is a del event and  $t_{j_{n-2}} = t_{j_{n-1}}$ . Since  $\langle x_{n-1}(p_{i_{n-1}}, t_{j_{n-1}}), x_n(p_{i_n}, t_{j_n}) \rangle \in B_1$ , we have  $p_{i_{n-1}} = p_{i_n} = p_j$  and  $t_{j_{n-1}} [po \cup rf]^+ t_{j_n}$ , i.e.  $t_{j_{n-2}} [po \cup rf]^+ t_2$ . From the inductive hypothesis we have  $t_1 [po \cup rf]^+ t_{j_{n-2}}$ . Hence we have  $t_1 [po \cup rf]^+ t_{j_n}$ , i.e.  $t_1 [po \cup rf]^+ t_2$ .

□

LEMMA A.2.  $<$  can be extended to a total order.

PROOF. We show that  $(B_1 \cup B_2 \cup B_3)^+$  is irreflexive. This allows us to extend  $<$  to a total order on  $Ev$ . First of all, notice that  $B_1 \cup B_2 \cup B_3$  is irreflexive since each of  $B_1, B_2, B_3$  are irreflexive. We first show that  $(B_1 \cup B_2)^+$  is irreflexive, and then use this to argue the irreflexivity of  $(B_1 \cup B_2 \cup B_3)^+$ .

**Irreflexivity of  $(B_1 \cup B_2)^+$ .** Assume otherwise. To obtain a  $(x, x) \in (B_1 \cup B_2)^+$ , we must compose  $B_1, B_2$ , as individually both  $B_1, B_2$  are reflexive.

- (1) Consider the case when we have  $\langle x(p_i, t_1), \text{isu}(p_j, t_2) \rangle, \langle \text{isu}(p_j, t_2), y(p_k, t_3) \rangle \in B_1 \cup B_2$ , and  $\langle y(p_k, t_3), x(p_i, t_1) \rangle \in (B_1 \cup B_2)^+$ . Since  $\langle x(p_i, t_1), \text{isu}(p_j, t_2) \rangle \in B_1$  and  $\langle y(p_k, t_3), x(p_i, t_1) \rangle \in (B_1 \cup B_2)^+$ , we have  $\langle y(p_k, t_3), \text{isu}(p_j, t_2) \rangle \in (B_1 \cup B_2)^+$ .

By Lemma A.1, it follows that  $t_3 [po \cup rf]^+ t_2$ .

- If  $y(p_k, t_3) = \text{isu}(p_k, t_3)$ .

Then  $\langle \text{isu}(p_j, t_2), y(p_k, t_3) \rangle = \langle \text{isu}(p_j, t_2), \text{isu}(p_k, t_3) \rangle \in B_1$ . Hence  $p_j = p_k$  and  $t_2 [po] t_3$ . Thus we get a cycle  $t_3 [po \cup rf]^+ t_2 [po] t_3$ . This contradicts the fact that  $(po \cup rf)^+$  is irreflexive.

- If  $y(p_k, t_3) = \text{del}(p_k, t_3)$ .

Then  $\langle \text{isu}(p_j, t_2), y(p_k, t_3) \rangle = \langle \text{isu}(p_j, t_2), \text{del}(p_k, t_3) \rangle \in B_2$  and  $t_2 = t_3$ , i.e. we get  $t_3 [po \cup rf]^+ t_3$ . This contradicts the fact that  $(po \cup rf)^+$  is irreflexive.

(2) Another possibility is  $\langle \text{isu}(p_i, t_1), \text{del}(p_j, t_2) \rangle \in B_2$ ,  $\langle \text{del}(p_j, t_2), y(p_k, t_3) \rangle \in B_1 \cup B_2$ , and  $\langle y(p_k, t_3), \text{isu}(p_i, t_1) \rangle \in (B_1 \cup B_2)^+$ . Combining  $\langle y(p_k, t_3), \text{isu}(p_i, t_1) \rangle \in (B_1 \cup B_2)^+$  and  $\langle \text{isu}(p_i, t_1), \text{del}(p_j, t_2) \rangle \in B_2$ , we get  $\langle y(p_k, t_3), \text{del}(p_j, t_2) \rangle \in (B_1 \cup B_2)^+$ .

- If  $y(p_k, t_3) = \text{isu}(p_k, t_3)$ .

Then  $\langle \text{del}(p_j, t_2), y(p_k, t_3) \rangle = \langle \text{del}(p_j, t_2), \text{isu}(p_k, t_3) \rangle \in B_1$ . Then  $p_j = p_k$  and  $t_2[po]t_3$ . Then we get the cycle  $t_3[po \cup rf]^+ t_2[po]t_3$ .

- If  $y(p_k, t_3) = \text{del}(p_k, t_3)$ .

Then  $\langle \text{del}(p_j, t_2), y(p_k, t_3) \rangle = \langle \text{del}(p_j, t_2), \text{del}(p_k, t_3) \rangle \in B_1$ . Then  $p_j = p_k$  and  $t_2[po]t_3$ . Then we get the cycle  $t_3[po \cup rf]^+ t_2[po]t_3$ .

Thus,  $(B_1 \cup B_2)^+$  is irreflexive.

**Irreflexivity of  $(B_1 \cup B_2 \cup B_3)^+$ .** Assume otherwise. To obtain  $(x, x) \in (B_1 \cup B_2 \cup B_3)^+$ , we must compose  $(B_1 \cup B_2)^+$  and  $B_3$  since, individually,  $(B_1 \cup B_2)^+$  and  $B_3$  are irreflexive. To this end, consider  $\langle x(p_i, t_1), \text{isu}(p_j, t_2) \rangle \in (B_1 \cup B_2)^+$  and  $\langle \text{isu}(p_k, t_3), \text{isu}(p_l, t_4) \rangle \in B_3$ . Then we have  $t_1[po \cup rf]^+ t_2$  and  $t_3[co]t_4$ . Assume a cycle in  $(B_1 \cup B_2 \cup B_3)^+$  involving  $t_1, t_2, t_3, t_4$ , of the form  $t_0[po \cup rf]^+ t'_0[co]t_1[po \cup rf]^+ t'_1[co] \cdots [po \cup rf]^+ t'_{n-1}[co]t_n[po \cup rf]^+ t'_n$  where  $t_0 = t'_n$ . This contradicts the fact that  $(po \cup rf \cup co)$  is acyclic.

The irreflexivity of  $(B_1 \cup B_2 \cup B_3)^+$  shows that we can extend  $<$  to a total order.  $\square$

We now show how to build an execution summary  $S = (Ev, <)$  using the events  $Ev$ , and the total order  $<$  which is legal and  $\tau'$ -consistent. Let the execution summary be  $S = \sigma_0 \xrightarrow{\ell_1} \sigma_1 \xrightarrow{\ell_2} \sigma_2 \xrightarrow{\ell_3} \sigma_3 \cdots \xrightarrow{\ell_{n-1}} \sigma_{n-1} \xrightarrow{\ell_n} \sigma_n$ .

$S = (Ev, <)$  is  $\tau'$ -consistent. We show that  $S$  satisfies all the conditions to be  $\tau'$ -consistent below.

- ★ First, each transaction  $t \in \mathcal{T}$  is issued in some unique process  $p_i$ . This is ensured by the total order  $<$ .
- ★ For  $t, t' \in \mathcal{T}$ , if  $t[po]t'$  in  $\tau'$ , we have  $t <_i t'$  by definition. This gives us  $(\text{isu}(p, t), \text{isu}(p, t')) \in B_1$ , giving  $\ell_i = \text{isu}(p, t), \ell_j = \text{isu}(p, t')$  in  $S$  with  $i < j$ .
- ★ For  $t, t' \in \mathcal{T}^w$ , if  $t[co]t'$  in  $\tau'$ , then  $(\text{isu}(p_i, t), \text{isu}(p_j, t')) \in B_3$ . Then we have  $\ell_i = \text{isu}(p_i, t), \ell_j = \text{isu}(p_j, t')$  with  $i < j$ .
- ★ For  $t, t' \in \mathcal{T}$ , if  $t'[rf^x]t$ , then we have  $t' <_i t$  by definition of  $<_i$ . This gives us  $(\text{del}(p, t'), \text{isu}(p, t)) \in B_1$ , giving  $\ell_i = \text{del}(p, t'), \ell_j = \text{isu}(p, t)$  with  $i < j$  in  $S$ ,  $t' \in \mathcal{T}^{w,x}, t \in \mathcal{T}^{r,x}$ . It remains to argue that  $t$  reads from the latest transaction which has written on  $x$  and delivered to it, and that is  $t'$ . We show this below in (1).

$S = (Ev, <)$  is a legal execution summary. To show this, we must show the three conditions of legality hold good.

Recall the function  $S.hb : \mathcal{T}^r \rightarrow \mathfrak{p}(\mathcal{T}^w)$  which associates a transaction  $t$  having a read event, with the set of transactions  $t'$  it can read from, defined as  $S.hb(t) = \{t' \in \mathcal{T}^w \mid \text{del}(p, t') < \text{isu}(p, t)\}$ . Recall also, the function  $S.lw : \mathcal{T}^r \times \mathcal{V} \rightarrow \mathcal{T}^w$ , which associates to each transaction  $t \in \mathcal{T}^r$ , the latest transaction in  $[co]^x$  order it can read  $x \in \mathcal{V}$  from. This is defined as  $S.lw(t, x) = \{t' \mid t' \in S.hb(t) \cap \mathcal{T}^{w,x}, t \in \mathcal{T}^{r,x} \text{ and } \forall t'' \in S.hb(t) \cap \mathcal{T}^{w,x}, t''.id \leq t'.id\}$

(1) The first condition is to show that, each transaction  $t$  in process  $p_i$  reads from the latest write, i.e.  $(S.lw(t, x) = t')$  when  $t'[rf^x]t$ . Let  $(\text{del}(p_i, t'), \text{isu}(p_i, t)) \in B_1$  with  $t' \in \mathcal{T}^{w,x}, t \in \mathcal{T}^{r,x}$ ,  $t' \in S.hb(t)$ , and  $t'[rf^x]t$ . We show that  $S.lw(t, x) = t'$ .

Assume otherwise, that is, there exists a transaction  $t'' \in \mathcal{T}^{w,x}$  such that  $(\text{del}(p_i, t''), \text{isu}(p_i, t)) \in B_1$  and  $S.lw(t, x) = t''$ . By Lemma A.1,  $t''[po \cup rf]^+ t$ . Since  $t' \in S.hb(t)$  and  $S.lw(t, x) = t''$ , we have  $t'.id \leq t''.id$ . Using  $t'[rf^x]t$ ,  $t''[po \cup rf]^+ t$  and the fact that  $\tau' \models \text{CCv}$ , we obtain

$t''[co^x]t'$ . This implies that  $t''.id < t'.id$  since we can have  $del(p, t'') < isu(p, t')$  but not the other way around, since  $t''[co^x]t'$  implies  $isu(-, t'') < isu(-, t')$ . This however contradicts  $t'.id \leq t''.id$ , and therefore contradicts  $S.lw(t, x) = t''$ . Thus,  $S.lw(t, x) = t'$ .

- (2) The second condition to prove is this : For transactions  $t, t' \in \mathcal{T}^w$ , if  $del(p, t) < isu(p, t')$ , then  $del(p', t) < del(p', t')$  for any  $p' \neq p$ . If we have  $del(p, t) < isu(p, t')$ , then  $(del(p, t), isu(p, t')) \in B_1$ . By definition of  $B_1$ , then we have  $t <_p t'$ . By Lemma A.1, we have  $(t, t') \in [po \cup rf]^+$ . By definition of  $<_{p'} = hb \cap A'_{p'} \times A'_{p'}$ , we obtain  $t <_{p'} t'$  since  $t, t' \in \mathcal{T}^w$ . By  $B_1$ ,  $t <_{p'} t'$  gives  $del(p', t) < del(p', t')$ .
- (3) The third condition is to show this : for each transaction  $t$  and processes  $p, p'$ ,  $isu(p, t) < del(p', t)$ . This is given to us by  $B_2$  already.

Thus, we have shown that we can construct a  $\tau'$ -consistent, legal execution summary from the CCv consistent trace  $\tau'$ .

### Legal Execution Summaries to CCv-consistent Traces

For the converse direction, assume that we begin with a legal execution summary  $Sum(\rho)$  corresponding to an execution  $\rho$ . First, we define the trace corresponding to  $\rho$ , denoted  $\tau = tr(\rho)$  following what we did in the main paper. To recall, given  $Sum(\rho) = (EvSum, <)$ ,

- For transactions  $t, t'$ , define  $t[po]t'$  when we have  $ev_1 = isu(p, t)$  and  $ev_2 = isu(p, t')$  such that  $ev_1 < ev_2$  in  $\tau$ . This corresponds to the order of transactions issued in process  $p$ .  $po$  does not relate the initializer transactions.
- $t[rf]t'$  relates transactions with delivery and issue events. If there exists  $ev_1 = del(p, t)$  and  $ev_2 = isu(p, t')$  such that  $ev_1 < ev_2$  in  $\tau$  such that  $t'$  performs an *external read* of some variable  $x$  and  $ev_1$  is the last event in  $\tau$  before  $ev_2$  that writes to  $x$ ,  $t = S.lw(t', x)$ . We say that  $t'$  performs an *external read* on a variable  $x$  in the run  $\rho$  if  $\rho$  has the read event  $r(p, t', x, v)$  which is not preceded by a  $w(p, t', x, v)$ . The variable  $x$  can be made explicit by defining  $t[rf^x]t'$ .
- $t[co]t'$  relates transactions writing on common variables. If there are events  $ev_1 = isu(p, t)$  and  $ev_2 = isu(q, t')$  such that  $ev_1 < ev_2$  in  $\tau$ , such that  $t_1, t_2$  both write on  $x$ , then  $t[co]t'$ . Note that the transaction  $init_x$  is such that  $init_x[co]t$  for all transitions  $t \in \mathcal{T}(\rho)^{w,x}$ .

We now show that the trace  $\tau$  as defined above is CCv consistent. For this, we have to show the following.

- (1) For each variable  $x$ ,  $co^x$  respects  $[po \cup rf^x]^+$ . Assume  $t[po \cup rf^x]^+t'$  for  $t, t' \in \mathcal{T}(\rho)^{w,x}$ . Then we have a sequence  $isu(p, t) < isu(p, t_p^1) < \dots < isu(p, t_p^n) < del(p, t_p^n) < del(p', t_p^n) < isu(p', t_p^1) < \dots < isu(q, t')$ . This gives  $isu(p, t) < isu(q, t')$ . By definition,  $t[co]^x t'$ .
- (2) Assume  $t_1[rf^x]t_2$  and  $t_3[po \cup rf]^+t_2$ . We show that  $t_3[co^x]t_1$ .

Assume otherwise, that is,  $t_1[co]t_3$ . Since  $t_3[po \cup rf]^+t_2$ , we have  $del(p_i, t_3) < isu(p_i, t_2)$ , i.e.  $t_3 \in S.hb(t_2)$ . Since  $t_1[co]t_3$ , we have  $isu(p_j, t_1) < isu(p_k, t_3)$ . Together with  $t_1, t_3 \in S.hb(t_2)$ , we have  $t_1 \neq S.lw(t_2, x)$ . Since  $t_1[rf^x]t_2$ , we have  $t_1 \in S.hb(t_2)$  and  $S.lw(t_2, x) = t_1$ . This is a contradiction.

- (3) Now we have to show that  $(po \cup rf \cup co)^+$  is acyclic.

It is clear that  $po$  cannot generate cycles, since it picks transactions in increasing order of their identifiers. Likewise,  $co$  is a total order, which is acyclic.

Assume we have a cycle in  $[po \cup rf]^+$ . This corresponds to a sequence  $isu(p, t) < \dots < del(q, t) < isu(q, t_1) < \dots < del(r, t_1) < isu(p, t)$ . However this gives us  $del(q, t) < isu(q, t_1)$  as well as  $del(r, t_1) < isu(p, t) < del(r, t)$ . The last inequality comes from the third condition

of a legal execution. However, this gives us  $\text{del}(q, t) < \text{isu}(q, t_1)$  and  $\text{del}(r, t_1) < \text{del}(r, t)$  contradicting the second condition of legal execution summaries.

Hence,  $(po \cup rf \cup co)^+$  is acyclic.  $\square$

## B CCv CONSISTENCY OF PARTIAL TRACES

### B.1 Adding Coherence Edges

For a trace  $\tau = \langle \mathcal{T}, po, rf, co \rangle$ , a variable  $x \in \mathcal{X}$ , and a pair  $(t, t') \in \mathcal{T}^{w,x} \times \mathcal{T}^{w,x}$ , we define  $\tau \odot (t_1, t_2) := (\mathcal{T}, po \cup rf \cup co')$ , where  $co' := co \cup \{(t_1, t_2)\}$ .

We first give an alternative definition for fulfilled traces.

LEMMA B.1. *A trace  $\tau = \langle \mathcal{T}, po, rf, co \rangle$  is fulfilled iff, for all transactions  $t, t' \in \mathcal{T}^{w,x}$ ,  $t \neq t'$ , whenever  $t [po \cup rf \cup co^x]^+ t''$  and  $t' [rf^x] t''$ , then  $t [po \cup rf \cup co^x]^+ t'$ .*

PROOF. Recall that we have defined a trace as fulfilled, if for all transactions  $t, t' \in \mathcal{T}^{w,x}$ ,  $t \neq t'$ , whenever  $t [po \cup rf]^+ t''$  and  $t' [rf^x] t''$ , then  $t [co^x]^+ t'$ . Now we show that the new condition in the lemma statement above implies this condition.

Show that the condition

$$t [po \cup rf \cup co^x]^+ t'' \text{ and } t' [rf^x] t'' \Rightarrow t [po \cup rf \cup co^x]^+ t'$$

implies the condition

$$t [po \cup rf]^+ t'' \text{ and } t' [rf^x] t'' \Rightarrow t [co^x]^+ t'.$$

Assume  $t [po \cup rf \cup co^x]^+ t''$ . This means either

- (1)  $t [po \cup rf]^+ t''$  (we do not have  $co^x$  edges from  $t$  to  $t''$ ), or
- (2)  $t [po \cup rf \cup co^x]^+ s [po \cup rf]^+ t''$ .

- (a) Assume (1). Then we have  $t [po \cup rf]^+ t''$  and  $t' [rf^x] t''$ . From the given condition we know  $t [po \cup rf \cup co^x]^+ t'$ . By assumption,  $\neg [t [po \cup rf \cup co^x]^+ t'']$ .

Note that if we conclude  $t [po \cup rf \cup co^x]^+ t'$ , then, with  $t' [rf^x] t''$ , we will also get  $t [po \cup rf \cup co^x]^+ t''$ , which by assumption (1) we do not. Thus, we have only  $t [co^x]^+ t'$ .

Thus we obtain  $t [po \cup rf]^+ t''$  and  $t' [rf^x] t''$  gives  $t [co^x]^+ t'$ .

- (b) Now consider condition (2), where we have  $t [po \cup rf \cup co^x]^+ s [po \cup rf]^+ t''$ , and  $t' [rf^x] t''$ . From (1) above, using  $s [po \cup rf]^+ t''$ , and  $t' [rf^x] t''$  we obtain  $s [co^x]^+ t'$ . Again, as in (1), if we allow only  $t [po \cup rf]^+ t''$ , then we need to have  $t [co^x]^+ s$ ; otherwise we will have  $t [po \cup rf \cup co^x]^+ s [po \cup rf]^+ t''$ . Hence,  $t [co^x]^+ s$  and  $s [co^x]^+ t'$  gives  $t [co^x]^+ t'$ .  $\square$

LEMMA B.2. *If  $\tau_1$  is fulfilled,  $t_1, t_2 \in \mathcal{T}^{w,x}$ ,  $t_1 \neq t_2$ , and  $\tau_2 = \tau_1 \odot (t_1, t_2)$  then  $\tau_2$  is fulfilled.*

PROOF. Let  $\tau_1 = (\mathcal{T}, po, rf, co_1)$ , and  $\tau_2 = (\mathcal{T}, po, rf, co_2)$ . Suppose that there are transactions  $t_3, t_4$ , and  $t_5$  such that  $t_3 [po \cup rf \cup co_2^x]^+ t_5$  and  $t_4 [rf^x] t_5$ . We show that  $t_3 [po \cup rf \cup co_2^x]^+ t_4$ . We consider two cases.

- (i)  $t_3 [po \cup rf \cup co_1^x]^+ t_5$ . Since  $\tau_1$  is fulfilled, we will have  $t_3 [po \cup rf \cup co_1^x]^+ t_4$ . Since  $\tau_1 \sqsubseteq \tau_2$  it follows that  $t_3 [po \cup rf \cup co_2^x]^+ t_4$ .
- (ii)  $t_3 [po \cup rf \cup co_1^x]^+ t_1$  and  $t_2 [po \cup rf \cup co_1^x]^+ t_5$ . Note that we added  $(t_1, t_2)$  as a new  $co$  edge to obtain  $\tau_2$ .

Since  $\tau_1$  is fulfilled,  $t_2 [po \cup rf \cup co_1^x]^+ t_4$ . Moreover,  $t_3 [po \cup rf \cup co_1^x]^+ t_1$  and  $\tau_1 \sqsubseteq \tau_2$ , so we have  $t_3 [po \cup rf \cup co_2^x]^+ t_1$ . Hence, we have  $t_3 [po \cup rf \cup co_2^x]^+ t_1 [co_2^x] t_2 [po \cup rf \cup co_2^x]^+ t_4$ , i.e., we have  $t_3 [po \cup rf \cup co_2^x]^+ t_4$ .

□

LEMMA B.3. Assume  $\tau_1 = \langle \mathcal{T}, po, rf, co_1 \rangle$  is fulfilled,  $\tau_1 \models CCv$ , and there exists  $t_1, t_2 \in \mathcal{T}^{w,x}$ , such that  $\neg[t_2(po \cup rf \cup co_1)^+ t_1]$ . Then  $\tau_2 = \tau_1 \odot (t_1, t_2)$  is such that  $\tau_2 \models CCv$ .

PROOF. Let  $\tau_1 = \langle \mathcal{T}, po, rf, co_1 \rangle$ . Assume we have a  $[po \cup rf \cup co]$  cycle in  $\tau_2 : t [po \cup rf \cup co_2]^+ t$ . Since  $\tau_1$  is fulfilled, it follows from Lemma B.2 that  $\tau_2$  is fulfilled. We consider two possible cases.

- (i)  $t [po \cup rf \cup co_1]^+ t$ . This contradicts the premise that  $[po \cup rf \cup co_1]^+$  is acyclic.
- (ii)  $t [po \cup rf \cup co_1]^+ t_1 [co_2^x] t_2 [po \cup rf \cup co_1]^+ t$ . This means that  $t_2 [po \cup rf \cup co_1]^+ t_1$  which contradicts the premise that  $\neg[t_2(po \cup rf \cup co_1)^+ t_1]$ .

Thus,  $(po \cup rf \cup co_2)^+$  is acyclic. Now for the rest of the conditions to show that  $\tau_2$  respects CCv.

Assume that  $\tau_2 \not\models CCv$ . Since  $\tau_2$  is fulfilled by Lemma B.2, the second condition for  $\models CCv$  holds good. Assume that  $co_2^x; [po \cup rf]^+$  is reflexive. Then we have  $(t_1, t_2) \in co_2^x$ , and  $t_2 [po \cup rf]^+ t_1$ . This however contradicts our assumption that  $\neg[t_2(po \cup rf \cup co_1)^+ t_1]$ . Hence  $\tau_2 \models CCv$ .

□

## B.2 Proof of Theorem 5.1

PROOF. Assume we have a fulfilled, partially good trace  $\tau = \langle \mathcal{T}, po, rf, co \rangle$ . By definition of partially good traces, we know that  $\tau \models CCv$  and  $(po \cup rf \cup co)^+$  is acyclic. To show that  $\tau$  is CCv consistent, we have to show that we can extend  $\tau$  to a total, CCv consistent trace  $\tau'$ .

For extending  $\tau$ , we construct a sequence of traces  $\tau = \tau_0 \sqsubseteq \tau_1 \sqsubseteq \tau_2, \dots$ , such that

- (1) Each  $\tau_i = \langle \mathcal{T}, po, rf, co_i \rangle$  is fulfilled,
- (2)  $\tau_i \models CCv$

If  $\tau_i$  is not total, then we generate trace  $\tau_{i+1} = \langle \mathcal{T}, po, rf, co_{i+1} \rangle$ , by adding  $t [co] t'$  to  $co_{i+1}$  for transactions  $t$  and  $t'$  which write on some same variable, such that  $\neg(t' [po \cup rf \cup co_i]^+ t)$  and  $\neg(t' [co_i] t)$ . As  $\tau_i$  is fulfilled,  $\tau_{i+1}$  is also fulfilled (Lemma B.2). Also,  $\tau_{i+1} \models CCv$  (Lemma B.3). If  $\tau_{i+1}$  is not total, then we generate trace  $\tau_{i+2}$ . We continue generating these new traces until we get a total trace  $\tau_n$ . We obtain  $\tau_n$  which is total and  $\tau_n \models CCv$ . Hence,  $\tau_n$  is CCv-consistent.

So, we successfully extended  $\tau$  to a CCv consistent total trace  $\tau_n$ . Hence,  $\tau$  is CCv consistent. □

## C PROPERTIES OF THE FULFILLED SEMANTICS

We show that all traces  $\tau$  generated in the fulfilled semantics are (i) fulfilled, and (ii)  $\tau \models CCv$ , and therefore, by Theorem 5.5 are CCv consistent. In particular, Lemma C.1, C.2, C.3 and C.4 imply Lemma 5.2.

LEMMA C.1. For traces  $\tau_1$  and  $\tau_2$  if  $\tau_1 \xrightarrow{(begin,t)}_{\text{ful}} \tau_2$ , and  $\tau_1$  is fulfilled then  $\tau_2$  is fulfilled.

PROOF. Let  $\tau_1 = \langle \mathcal{T}_1, po_1, rf_1, co_1 \rangle$  and  $\tau_2 = \langle \mathcal{T}_2, po_2, rf_2, co_2 \rangle$ . Assume  $\tau_1$  is fulfilled. By definition of  $\xrightarrow{(begin,t)}_{\text{ful}}$  it follows that  $\mathcal{T}_1 \subseteq \mathcal{T}_2, po_1 \subseteq po_2, rf_1 \subseteq rf_2$ , and  $co_1 \subseteq co_2$ . Assume that  $t_1 [po_2 \cup rf_2 \cup co_2]^+ t_2$ , and  $t' [rf_2^y] t_2$ . The newly added transaction  $t \in \mathcal{T}_2$  has no successors in  $po_2 \cup rf_2 \cup co_2$ , hence it follows that  $t_1 [po_1 \cup rf_1 \cup co_1]^+ t_2$  and  $t' [rf_1^y] t_2$ . As  $\tau_1$  is fulfilled, we have  $t_1 [po_1 \cup rf_1 \cup co_1]^+ t'$ , and hence  $t_1 [po_2 \cup rf_2 \cup co_2]^+ t'$ . Thus,  $\tau_2$  is fulfilled whenever  $\tau_1$  is.

□

LEMMA C.2. For traces  $\tau_1$  and  $\tau_2$  if  $\tau_1 \xrightarrow{(read,t,t')}_{\text{ful}} \tau_2$ , and  $\tau_1$  is fulfilled then  $\tau_2$  is fulfilled.

PROOF. Let  $\tau_1 = \langle \mathcal{T}_1, po_1, rf_1, co_1 \rangle, \tau_2 = \langle \mathcal{T}_2, po_2, rf_2, co_2 \rangle$ . Let  $ev = r(p, t, x, v)$  be the read event in  $t$ , and let  $t' \in \text{readable}(\tau, t, x)$  be the chosen transaction that  $t$  reads from, while  $\tau_1 \xrightarrow{(read,t,t')}_{\text{ful}} \tau_2$ . Then  $\mathcal{T}_2 = \mathcal{T}_1, rf_2 = rf_1 \cup (t', t), co_2 = co_1 \cup \{(t'', t') \mid t'' \in \text{visible}(\tau, t, x)\} \cup \{(t', t_2) \mid t' \in$

$\mathcal{T}_1^{w,y}$ , and  $t_2[rf_2^y]t$ . Assume for any two transactions  $t_1, t_2$  and any variable  $y$ ,  $t_1[po_2 \cup rf_2 \cup co_2^y]^+ t_3$  and  $t_2[rf_2^y]t_3$ . We show that  $t_1[po_2 \cup rf_2 \cup co_2^y]^+ t_2$ . Since  $t$  has no successors in  $po_2 \cup rf_2 \cup co_2$ , we only need to consider the following cases.

- $y = x$ ,  $t_3 = t$ ,  $t_2 = t'$  and there is a transaction  $t_4 \in \text{visible}(\tau, t, x)$  such that  $t_1[po_1 \cup rf_1 \cup co_1^x]^* t_4$ . From the definition of  $\xrightarrow[\text{ful}]{(read,t,t')}$ , we have  $t_4[co_2^x]t_2$ . Since  $t_1[po_1 \cup rf_1 \cup co_1^x]^* t_4$ , we also have  $t_1[po_2 \cup rf_2 \cup co_2^x]^* t_4$ . So we have  $t_1[po_2 \cup rf_2 \cup co_2^x]^+ t_4[co_2^x]t_2$ .
- $y = x$  and there is a transaction  $t_4 \in \text{visible}(\tau, t, x)$ . By definition of  $\xrightarrow[\text{ful}]{(read,t,t')}$  we have  $t_4[co_2^x]t'$ .

By assumption we have  $t_1[po_2 \cup rf_2 \cup co_2^x]^+ t_3$  and  $t_2[rf_2^x]t_3$ . Indeed  $t_2[rf_1^x]t_3$ , since the only new  $rf$  added to  $\tau_2$  is  $(t', t)$ . We do not have  $t_1[po_1 \cup rf_1 \cup co_1^x]^+ t_3$ , since otherwise along with  $t_2[rf_1^x]t_3$  and the fulfilledness of  $\tau_1$  will result in  $t_1[po_1 \cup rf_1 \cup co_1^x]^+ t_2$  and hence  $t_1[po_2 \cup rf_2 \cup co_2^x]^+ t_2$ .

Thus,  $t_1[po_2 \cup rf_2 \cup co_2^x]^+ t_3$  is obtained using the new  $t_4[co_2^x]t'$  edge as  $t_1[po_1 \cup rf_1 \cup co_1^x]^* t_4[co_2^x]t'[po_1 \cup rf_1 \cup co_1^x]^+ t_3$ .

We know that  $\tau_1$  is fulfilled, and we also have  $t_2[rf_2^y]t_3$ . Together with  $t'[po_1 \cup rf_1 \cup co_1^x]^+ t_3$ , this gives the following.

- (1) either  $t_2[rf_1^y]t_3$  assuming  $\neg(t_2 = t' \wedge t_3 = t)$ , in which case the fulfilled status of  $\tau_1$  gives  $t'[po_1 \cup rf_1 \cup co_1^x]^+ t_2$  i.e.  $t'[po_2 \cup rf_2 \cup co_2^x]^+ t_2$ ,
- (2)  $\neg(t_2[rf_1^y]t_3)$ . Then  $t_2[rf_2^y]t_3$  is the new reads from introduced, which means  $t_2 = t'$ ,  $t_3 = t$ . This is already handled by the above bullet. So we again have  $t'[po_1 \cup rf_1 \cup co_1^x]^+ t_2$  and hence  $t'[po_2 \cup rf_2 \cup co_2^x]^+ t_2$ .

Since  $t_1[po_1 \cup rf_1 \cup co_1^x]^* t_4$  and  $t'[po_1 \cup rf_1 \cup co_1^x]^+ t_3$ , it follows that  $t_1[po_2 \cup rf_2 \cup co_2^x]^* t_4$  and  $t'[po_2 \cup rf_2 \cup co_2^x]^+ t_3$ . That is, we have  $t_1[po_2 \cup rf_2 \cup co_2^x]^* t_4[co_2^x]t'[po_2 \cup rf_2 \cup co_2^x]^+ t_2$ . Hence  $t_1[po_2 \cup rf_2 \cup co_2^x]^+ t_2$ .

- $y \neq x$ . By assumption, we have  $t_1[po_2 \cup rf_2 \cup co_2^y]^+ t_3$  and  $t_2[rf_2^y]t_3$ . We show that  $t_1[po_2 \cup rf_2 \cup co_2^y]^+ t_2$ . Note that the only new  $rf_2$  added to  $\tau_2$  is  $(t', t)$ , hence we also have  $t_2[rf_1^y]t_3$ . Indeed we do not have  $t_1[po_1 \cup rf_1 \cup co_1^y]^+ t_3$ : else the fulfilled status of  $\tau_1$  will already give us  $t_1[po_1 \cup rf_1 \cup co_1^y]^+ t_2$  and hence  $t_1[po_2 \cup rf_2 \cup co_2^y]^+ t_2$ .

Assume there is a transaction  $t_4$  such that  $t_4[rf_1^y]t$ ,  $y \neq x$ , and let  $t' \in \text{readable}(\tau, t, x)$  be such that  $t' \in \mathcal{T}_1^{w,y} \cap \mathcal{T}^{w,x}$ . Now by the definition of  $\xrightarrow[\text{ful}]{(read,t,t')}$ ,  $t' \in \mathcal{T}_1^{w,y}$  and  $t_4[rf_1^y]t$  gives  $(t', t_4) \in [co_2]^y$ .

By assumption, we have  $t_1[po_2 \cup rf_2 \cup co_2^y]^+ t_3$ . Since we did not have  $t_1[po_1 \cup rf_1 \cup co_1^y]^+ t_3$ , using  $t'[co_2]^y t_4$ , we can obtain  $t_1[po_2 \cup rf_2 \cup co_2^y]^+ t_3$  as follows:  $t_1[po_1 \cup rf_1 \cup co_1^y]^* t'[co_2]^y t_4[po_1 \cup rf_1 \cup co_1^y]^+ t_3$ . We have  $t_2[rf_2^y]t_3$ , which gives  $t_2[rf_1^y]t_3$ , since the only new  $rf_2$  added is  $(t', t)$ .

The fulfilled status of  $\tau_1$  along with  $t_4[po_1 \cup rf_1 \cup co_1^y]^+ t_3$  and  $t_2[rf_1^y]t_3$  gives  $t_4[po_1 \cup rf_1 \cup co_1^y]^+ t_2$ . Then we have  $t_1[po_2 \cup rf_2 \cup co_2^y]^* t'[co_2]^y t_4[po_1 \cup rf_1 \cup co_1^y]^+ t_2$ . This gives us  $t_1[po_2 \cup rf_2 \cup co_2^y]^+ t_2$ . □

LEMMA C.3. If  $\tau_1 \models \text{CCv}$  and  $\tau_1 \xrightarrow[\text{ful}]{(begin,t)} \tau_2$  then  $\tau_2 \models \text{CCv}$ .

PROOF. The proof follows trivially since we do not change the reads from and coherence order relations, and the transaction  $t$  added to the partial order has no successors. Thus, if  $\tau_1 \models \text{CCv}$ , so does  $\tau_2$ . □



LEMMA C.4. If  $\tau_1 \models \text{CCv}$  and  $\tau_1 \xrightarrow{(\text{read}, t, t')}_{\text{ful}} \tau_2$  then  $\tau_2 \models \text{CCv}$ .

PROOF. Let  $\tau_1 = \langle \mathcal{T}_1, \text{po}_1, \text{rf}_1, \text{co}_1 \rangle$ ,  $\tau_2 = \langle \mathcal{T}_2, \text{po}_2, \text{rf}_2, \text{co}_2 \rangle$ , and  $ev = r(p, t, x, v)$  be a read event in transaction  $t \in \mathcal{T}_1$ . Suppose  $\tau_2 \not\models \text{CCv}$ , and that  $\text{po}_2 \cup \text{rf}_2 \cup \text{co}_2$  is cyclic. Since  $\tau_1 \models \text{CCv}$ , and  $t$  has no outgoing edges, on adding  $(t', t) \in \text{rf}_2$ , it follows that the cycle in  $\tau_2$  is as a result of the newly added  $\text{co}_2$  edges.

We prove that on adding  $(t', t) \in \text{rf}_2$ , such cycles are possible iff at least one of  $\text{cond}_1, \dots, \text{cond}_4$  are true.

$\text{cond}_1 \vee \dots \vee \text{cond}_4$  **induces**  $\text{po}_2 \cup \text{rf}_2 \cup \text{co}_2$  **cyclicity**

This direction is easy to see : assume one of  $\text{cond}_1, \dots, \text{cond}_4$  are true; then, as already argued in the main paper, we will get a  $\text{po}_2 \cup \text{rf}_2 \cup \text{co}_2$  cycle on adding the  $\text{rf}_2$  edge from  $t'$  to  $t$  and we are done.

$\text{po}_2 \cup \text{rf}_2 \cup \text{co}_2$  **cyclicity implies**  $\text{cond}_1 \vee \dots \vee \text{cond}_4$

For the converse direction, assume that we add the  $\text{rf}_2$  edge from  $t'$  to  $t$  and obtain a  $\text{po}_2 \cup \text{rf}_2 \cup \text{co}_2$  cycle in  $\tau_2$ . We now argue that this cycle has been formed because one of  $\text{cond}_1, \dots, \text{cond}_4$  are true.

First of all, note that  $t$  has no outgoing edges in  $\tau_2$ , since it is the current transaction being executed. Also, we know that  $\tau_1$  has no  $\text{po}_1 \cup \text{rf}_1 \cup \text{co}_1$  cycles. Thus, the cyclicity of  $\text{po}_2 \cup \text{rf}_2 \cup \text{co}_2$  is induced by the newly added  $\text{rf}_2$  edge as well as the newly added  $\text{co}_2$  edges. Note that adding the  $\text{rf}_2$  edge to  $\tau_1$  does not induce any cycle since  $t$  has no outgoing edges. Lets analyze the  $\text{co}_2$  edges added which induce cycles, and argue that one of  $\text{cond}_1, \dots, \text{cond}_4$  will be true.

- (1) We add  $\text{co}_2$  edges from  $t'' \in \text{readable}(\tau_1, t, x)$  to  $t'$ . For these edges to induce a cycle, we should have a path from  $t'$  to  $t''$  in  $\tau_1$ . That is, we have  $t'[\text{po}_1 \cup \text{rf}_1 \cup \text{co}_1]^+ t''$ . This is captured by  $\text{cond}_1$ .
- (2) Consider  $y \neq x$ . If  $t' \in \mathcal{T}^{w,x} \cap \mathcal{T}^{w,y}$ , and we have  $t''' \text{rf}_1^y t$ . Then we add  $(t', t''') \in \text{co}_2^y$ . To get a cycle, we need a path from  $t'''$  to  $t'$ .
  - If  $t''' \in \mathcal{T}^{w,x} \cap \mathcal{T}^{w,y}$ , then we add  $(t''', t') \in \text{co}_2^x$ , resulting in a cycle. This is handled by  $\text{cond}_2$ .
  - If we have a path  $t'''[\text{po}_1 \cup \text{rf}_1 \cup \text{co}_1]^+ t'$ , then we get a cycle again. This is handled by  $\text{cond}_3$ .
  - As a last case, to obtain a path from  $t'''$  to  $t'$ , assume there is a path from  $t'''$  to  $t$  in  $\tau_1$ , and let  $t'' \in \mathcal{T}^{w,x}$  be the last transaction writing to  $x$  in this path. Note that this will induce a path from  $t'''$  to  $t''$  to  $t'$  : the path from  $t''$  to  $t'$  comes by the  $\text{co}_2^x$  edge added from  $t''$  to  $t'$  since we have  $(t', t) \in \text{rf}_2^x$ . Once we get this path from  $t'''$  to  $t'$ , we again have the path we were looking for to get the cycle. This is handled by  $\text{cond}_4$ .

Thus, we have shown that obtaining a path from  $t'''$  to  $t'$  is covered by the conditions  $\text{cond}_1, \dots, \text{cond}_4$ , and hence, a  $\text{po}_2 \cup \text{rf}_2 \cup \text{co}_2$  cycle.

Thus, we can think of  $\text{po}_2 \cup \text{rf}_2 \cup \text{co}_2$  cycles as a result of the forbidden patterns described in  $\text{cond}_i$   $1 \leq i \leq 4$ . By construction of  $\tau_1 \xrightarrow{(\text{read}, t, t')}_{\text{ful}} \tau_2$ , we ensure  $\neg \text{cond}_1, \dots, \neg \text{cond}_4$ . Hence,  $\tau_2 \models \text{CCv}$ .

□

## D EFFICIENCY OF COMPUTING READABLE AND VISIBLE SETS

### D.1 Proof of Lemma 5.4

PROOF. We prove that set  $\text{readable}(\tau, t, x)$  can be computed in polynomial time, by designing an algorithm to generate set  $\text{readable}(\tau, t, x)$ . The algorithm consists of the following steps:

- (i) First we compute the transitive closure of the relation  $[po \cup rf \cup co]$ , i.e, we compute  $[po \cup rf \cup co]^+$ . We can use the Floyd-Warshall algorithm [Cormen et al. 2009] to compute the transitive closure. This will take  $O(|\mathcal{T}|^3)$  time.
- (ii) We compute the set  $\mathcal{T}' = \{t' \mid t'[po \cup rf]^*t\}$ . This takes  $O(|\mathcal{T}|^2)$  time.
- (iii) We compute the set  $\mathcal{T}'' = \{t' \mid t' \in \mathcal{T}' \wedge \neg(\exists t''.(t'[po \cup rf \cup co]^*t''))\}$ . It takes  $O(|\mathcal{T}|^2)$  time.
- (iv) For each transaction  $t' \in \mathcal{T}^{w,x}$ , we perform following checks:
  - Check cond1 : Check whether there exists a transaction  $t'' \in \mathcal{T}' \cap \mathcal{T}^{w,x}$  with  $t' [po \cup rf \cup co]^+ t''$ . If there is no such  $t''$  then proceed to cond2. If we find such  $t''$ , then  $t' \notin \text{readable}(\tau, t, x)$ . This step will take  $O(|\mathcal{T}|^2)$  time.
  - Check cond2 : Check whether there exists a transaction  $t''$  such that  $t''[rf^y]t$  and  $t', t'' \in \mathcal{T}^{w,x} \cap \mathcal{T}^{w,y}$ . If there is no such  $t''$  then proceed to cond3. If we find such  $t''$ , then  $t' \notin \text{readable}(\tau, t, x)$ . This step will take  $O(|\mathcal{T}|)$  time.
  - Check cond3 :  
 We first check case 1 of cond3. Check whether there exists a transaction  $t''$  such that  $t''[rf^y]t$ ,  $t' \in \mathcal{T}^{w,y}$ , and  $t''[po \cup rf \cup co]^+t'$ . If there is no such  $t''$  then proceed to case two of cond3. If we find such  $t''$ , then  $t' \notin \text{readable}(\tau, t, x)$ . This step will take  $O(|\mathcal{T}|)$  time.  
 Next, we check case 2 of cond3. Check whether there are transactions  $t''$  and  $t'''$  such that  $t''[rf^y]t$ ,  $t''' \in \mathcal{T}^{w,y}$ ,  $t'''[po \cup rf \cup co]^+t'$  and  $t''[po \cup rf \cup co]^+t'''$ . If there are no such  $t''$  and  $t'''$  then proceed to cond4. If we find such  $t''$  and  $t'''$ , then  $t' \notin \text{readable}(\tau, t, x)$ . This step will take  $O(|\mathcal{T}|^2)$  time.
  - Check cond4 : Check whether there are transactions  $t''$  and  $t'''$  such that  $t''[rf^y]t$ ,  $t''' \in \mathcal{T}''$  and  $t''[po \cup rf \cup co]^+t'''$ . If we find such  $t''$  and  $t'''$ , then  $t' \notin \text{readable}(\tau, t, x)$ . If there are no such  $t''$  and  $t'''$  then add  $t'$  to  $\text{readable}(\tau, t, x)$ . This step will take  $O(|\mathcal{T}|^2)$  time.

Similarly, we can compute  $\text{visible}(\tau, t, x)$  in polynomial time. This completes the proof.  $\square$

## E INCREMENTAL TOTAL SEMANTICS

In this section, we show that the weakenings of traces generated by the fulfilled semantics coincide with the weakenings of CCv consistent traces. To this end, we introduce a new *incremental* semantics that is equivalent to the total CCv semantics. The *incremental semantics* derives the total, CCv consistent traces in an incremental fashion, step by step, and is used in the proof of Theorem 5.5.

The *incremental semantics* is given as the transition relation  $\rightarrow_{\text{Inc}}$  on pairs of configurations and traces, defined as  $(\sigma, \tau) \xrightarrow{\alpha}_{\text{Inc}} (\sigma', \tau')$ . The label  $\alpha$  is one of the following (i) a begin transaction (*begin*,  $t$ ), (ii) a (*write*,  $t$ ) corresponding to a write event  $w(p, t, x, v)$  in  $t$ , (iii) a triple (*read*,  $t, t'$ ) corresponding to a read event  $r(p, t, x, v)$  in transaction  $t$ , and transaction  $t'$  which  $t$  reads from, and (iv) an end transaction (*end*,  $t$ ). The transitions are described below.

- Transition  $(\sigma, \tau) \xrightarrow{(\text{begin}, t)}_{\text{Inc}} (\sigma', \tau')$  represents extending a total trace after visiting a *begin*( $p, t$ ) event. Here,  $\tau = \langle \mathcal{T}, po, rf, co \rangle$ ,  $\tau' = \langle \mathcal{T}', po', rf', co' \rangle$ ,  $\mathcal{T}' = \mathcal{T} \cup \{t\}$  and  $po' = po \cup \{(t', t) \mid t' \text{ is the last transaction from } p \text{ which has been executed}\}$ .

- Transition  $(\sigma, \tau) \xrightarrow{\text{Inc}}^{(\text{write}, t)} (\sigma', \tau')$ , where  $ev = w(p, t, x, v)$ ,  $\tau = \langle \mathcal{T}, po, rf, co \rangle$ ,  $\tau' = \langle \mathcal{T}', po', rf', co' \rangle$ ,  $\mathcal{T}' = \mathcal{T}$ ,  $po' = po$ ,  $rf' = rf$ ,  $co \subseteq co'$  and  $co'$  is a total order, describing how to extend the total trace  $\tau$  after visiting the write event  $ev$  in transaction  $t$ , on variable  $x$ .
- Transition  $(\sigma, \tau) \xrightarrow{\text{Inc}}^{(\text{read}, t, t')} (\sigma', \tau')$  represents extending the total trace  $\tau$  after visiting a read event  $ev = r(p, t, x, v)$  in transaction  $t$ , and  $t$  reads from transaction  $t'$ . Here,  $\tau = \langle \mathcal{T}, po, rf, co \rangle$ ,  $\tau' = \langle \mathcal{T}', po', rf', co' \rangle$ ,  $\mathcal{T}' = \mathcal{T}$ ,  $po' = po$ ,  $rf' = rf \cup \{(t', t)\}$ ,  $co' = co$ .
- Transition  $(\sigma, \tau) \xrightarrow{\text{Inc}}^{(\text{end}, t)} (\sigma', \tau')$ , where  $\sigma' = \sigma$ , and  $\tau' = \tau$  describes extending trace after visiting end event.

We define  $[[\sigma]]^{\text{Inc}} = \{\tau \mid \exists \sigma'. \langle \sigma, \tau_0 \rangle \xrightarrow{*}_{\text{Inc}} \langle \sigma', \tau \rangle\}$  as the set of traces generated according to the *incremental semantics* starting from configuration  $\sigma$  and the empty trace  $\tau_0$ . We define  $[[\sigma]]_{\text{CCv}}^{\text{Inc}} = [[\sigma]]^{\text{Inc}} \cap \{\tau \mid \tau \text{ is CCv consistent}\}$ . That is, it is the set of total traces  $\tau$  such that  $\tau \models \text{CCv}$ , generated by runs according to the incremental semantics starting from configuration  $\sigma$  and the empty trace.

Starting from a configuration  $\sigma$ , for each run in the total CCv semantics leading to a trace  $\tau = \langle \mathcal{T}, po, rf, co \rangle$  there is a corresponding run  $[[\sigma]]_{\text{CCv}}^{\text{Inc}}$  in the incremental semantics where the events are scheduled according to the relations  $po, rf, co$ , and conversely. Hence we obtain

$$\text{LEMMA E.1. } [[\sigma]]_{\text{CCv}}^{\text{Inc}} = [[\sigma]]_{\text{CCv}}.$$

## F SOUNDNESS OF THE DPOR ALGORITHM

We prove Theorem 5.5 below.

### F.1 Proof of Theorem 5.5

We prove the two directions in the coming two subsections. First, in section F.2, we show that all the weakenings of fulfilled traces are also the weakenings of CCv consistent traces. Then, in section F.3, we show the converse direction, namely, weakenings of CCv consistent traces are also weakenings of fulfilled traces.

$$\text{F.2 } \{\text{weak}(\tau) \mid \tau \in [[\sigma]]_{\text{CCv}}^{\text{ful}}\} \subseteq \{\text{weak}(\tau) \mid \tau \in [[\sigma]]_{\text{CCv}}\}$$

LEMMA F.1. If  $(\sigma, \tau_1) \xrightarrow{\text{ful}}^{(\text{begin}, t)} (\sigma', \tau_2)$ ,  $\tau_2 \sqsubseteq \tau_4$ , and  $\tau_4$  is total then there exists a  $\tau_3$  such that  $(\sigma, \tau_3) \xrightarrow{\text{Inc}}^{(\text{begin}, t)} (\sigma', \tau_4)$  and  $\tau_1 \sqsubseteq \tau_3$ .

PROOF. Let  $\tau_1 = \langle \mathcal{T}_1, po_1, rf_1, co_1 \rangle$ ,  $\tau_2 = \langle \mathcal{T}_2, po_2, rf_2, co_2 \rangle$ , and  $\tau_4 = \langle \mathcal{T}_4, po_4, rf_4, co_4 \rangle$ . By definition of  $\xrightarrow{\text{ful}}^{(\text{begin}, t)}$ , we have  $\mathcal{T}_2 = \mathcal{T}_1$ ,  $po_2 = po_1 \cup \{(t', t) \mid t' \text{ is the last transaction executed in process } p\}$ ,  $rf_2 = rf_1$ , and  $co_2 = co_1$ . Since  $\tau_2 \sqsubseteq \tau_4$  it follows that  $\mathcal{T}_4 = \mathcal{T}_2$ ,  $po_4 = po_2$ ,  $rf_4 = rf_2$ , and  $co_2 \subseteq co_4$ .

Define  $\tau_3 = \langle \mathcal{T}_3, po_3, rf_3, co_3 \rangle$  such that  $\mathcal{T}_3 = \mathcal{T}_1$ ,  $po_3 = po_1$ ,  $rf_3 = rf_1$ , and  $co_3 = co_4|_{\mathcal{T}_3}$ , is the order  $co_4$  restricted to  $\mathcal{T}_3$ . It follows that  $(\sigma, \tau_3) \xrightarrow{\text{Inc}}^{(\text{begin}, t)} (\sigma', \tau_4)$ . We need to show that  $co_1 \subseteq co_3$ . Consider  $t [co_1] t'$ . It follows that  $t [co_2] t'$  and hence  $t [co_4] t'$ . Since  $t, t' \in \mathcal{T}_1$ ,  $co_3 = co_4|_{\mathcal{T}_3}$ , and  $\mathcal{T}_3 = \mathcal{T}_1$ , we have  $t [co_3] t'$ .  $\square$

LEMMA F.2. If  $(\sigma, \tau_1) \xrightarrow{\text{ful}}^{(\text{write}, t)} (\sigma', \tau_2)$ ,  $\tau_2 \sqsubseteq \tau_4$ , and  $\tau_4$  is total then there exists a  $\tau_3$  such that  $(\sigma, \tau_3) \xrightarrow{\text{Inc}}^{(\text{write}, t)} (\sigma', \tau_4)$  and  $\tau_1 \sqsubseteq \tau_3$ .

PROOF. This follows trivially by the definition of the fulfilled semantics  $\xrightarrow{\text{ful}}^{(\text{write}, t)}$ . Note that  $\sigma = \sigma'$ , and  $\tau_1 = \tau_2$ . Hence, one can choose  $\tau_3 = \tau_4$  obtaining  $(\sigma, \tau_3) \xrightarrow{\text{Inc}}^{(\text{write}, t)} (\sigma', \tau_4)$ .  $\square$

LEMMA F.3. *If  $(\sigma, \tau_1) \xrightarrow{\text{ful}}^{(\text{end}, t)} (\sigma', \tau_2)$ ,  $\tau_2 \sqsubseteq \tau_4$ , and  $\tau_4$  is total then there exists a  $\tau_3$  such that  $(\sigma, \tau_3) \xrightarrow{\text{Inc}}^{(\text{end}, t)} (\sigma', \tau_4)$  and  $\tau_1 \sqsubseteq \tau_3$ .*

PROOF. This follows in the same lines as Lemma F.2.  $\square$

LEMMA F.4. *If  $(\sigma, \tau_1) \xrightarrow{\text{ful}}^{(\text{read}, t, t')} (\sigma', \tau_2)$ ,  $\tau_2 \sqsubseteq \tau_4$ , and  $\tau_4$  is total then there exists a  $\tau_3$  such that  $(\sigma, \tau_3) \xrightarrow{\text{Inc}}^{(\text{read}, t, t')} (\sigma', \tau_4)$  and  $\tau_1 \sqsubseteq \tau_3$ .*

PROOF. Let  $\tau_1 = \langle \mathcal{T}_1, \mathbf{po}_1, \mathbf{rf}_1, \mathbf{co}_1 \rangle$ ,  $\tau_2 = \langle \mathcal{T}_2, \mathbf{po}_2, \mathbf{rf}_2, \mathbf{co}_2 \rangle$ , and  $\tau_4 = \langle \mathcal{T}_4, \mathbf{po}_4, \mathbf{rf}_4, \mathbf{co}_4 \rangle$ . By definition of  $\xrightarrow{\text{ful}}^{(\text{read}, t, t')}$ , we have  $ev = r(p, t, x, v)$ ,  $\mathcal{T}_2 = \mathcal{T}_1$ ,  $\mathbf{po}_2 = \mathbf{po}_1$ ,  $\mathbf{rf}_2 = \mathbf{rf}_1 \cup t'[\mathbf{rf}]t$ , and  $\mathbf{co}_2 = \mathbf{co}_1 \cup \mathbf{co}'_2$ , where  $\mathbf{co}'_2 = \mathbf{co}_1 \cup \{t''[\mathbf{co}]t' \mid t'' \in \text{visible}(\tau_1, t, x)\}$ , and, if there exists  $t_2 [rf_1]^y t$ , and  $t' \in \mathcal{T}_1^{\text{w}, y}$ , then  $\mathbf{co}'_2 = \mathbf{co}'_2 \cup t'[\mathbf{co}]t_2$ . Since  $\tau_2 \sqsubseteq \tau_4$  it follows that  $\mathcal{T}_4 = \mathcal{T}_2$ ,  $\mathbf{po}_4 = \mathbf{po}_2$ ,  $\mathbf{rf}_4 = \mathbf{rf}_2$ , and  $\mathbf{co}_2 \subseteq \mathbf{co}_4$ .

Define  $\tau_3 = \langle \mathcal{T}_3, \mathbf{po}_3, \mathbf{rf}_3, \mathbf{co}_3 \rangle$  such that  $\mathcal{T}_3 = \mathcal{T}_1$ ,  $\mathbf{po}_3 = \mathbf{po}_1$ ,  $\mathbf{rf}_3 = \mathbf{rf}_1 = \mathbf{rf}_4|_{\mathcal{T}_3}$ ,  $\mathbf{co}_3 = \mathbf{co}_4|_{\mathcal{T}_3}$ . It follows that  $\tau_3 \xrightarrow{\text{Inc}}^{(\text{read}, t, t')} \tau_4$ .

We show that  $\mathbf{co}_1 \subseteq \mathbf{co}_3$ . Consider  $t_1 [\mathbf{co}_1] t_2$ . It follows that  $t_1 [\mathbf{co}_2] t_2$  and hence  $t_1 [\mathbf{co}_4] t_2$ . Since  $t_1, t_2 \in \mathcal{T}_1$  and  $\mathbf{co}_3 = \mathbf{co}_4|_{\mathcal{T}_3}$ , we obtain  $t_1 [\mathbf{co}_3] t_2$ .  $\square$

LEMMA F.5. *If  $(\sigma, \tau_1) \xrightarrow{\text{ful}}^* (\sigma', \tau_2)$ ,  $\tau_2 \sqsubseteq \tau_4$ , and  $\tau_4$  is total then there exists a  $\tau_3$  such that  $(\sigma, \tau_3) \xrightarrow{\text{Inc}}^* (\sigma', \tau_4)$  and  $\tau_1 \sqsubseteq \tau_3$ .*

PROOF. Follows from Lemmas F.1 to F.4.  $\square$

LEMMA F.6.  $\{\text{weak}(\tau)|\tau \in [[\sigma]]_{\text{CCv}}^{\text{ful}}\} \subseteq \{\text{weak}(\tau)|\tau \in [[\sigma]]_{\text{CCv}}^{\text{Inc}}\}$  for any configuration  $\sigma$ .

PROOF. Assume  $\tau \in [[\sigma]]_{\text{CCv}}^{\text{ful}}$ . We show that there is a trace  $\tau'$  s.t.  $\tau' \in [[\sigma]]_{\text{CCv}}^{\text{Inc}}$  s.t.  $\tau \sqsubseteq \tau'$ . Then we obtain the result.

Since  $\tau \in [[\sigma]]_{\text{CCv}}^{\text{ful}}$ , we know that  $(\sigma, \tau_0) \xrightarrow{\text{ful}}^* (\sigma', \tau)$  for some configuration  $\sigma'$ . That is, there is a sequence  $(\sigma_0, \tau_0) \rightarrow_{\text{ful}} (\sigma_1, \tau_1) \rightarrow_{\text{ful}} (\sigma_2, \tau_2) \rightarrow_{\text{ful}} \dots \rightarrow_{\text{ful}} (\sigma_n, \tau_n)$  with  $\sigma_0 = \sigma$ ,  $\tau_0 = \tau_0$ ,  $\sigma_n = \sigma'$  and  $\tau_n = \tau$ . Since  $\tau_0$  is a fulfilled trace, and  $\tau_0 \models \text{CCv}$ , it follows by Lemmas C.1, C.2, C.3 and C.4 that  $\tau$  is fulfilled and  $\tau \models \text{CCv}$ . By Theorem 5.1 it follows that  $\tau$  is CCv consistent, that is, there is a total trace  $\tau'$  s.t.  $\tau \sqsubseteq \tau'$  and  $\tau' \models \text{CCv}$ . By Lemma F.5, there is a sequence  $(\sigma_0, \tau'_0) \rightarrow_{\text{Inc}} (\sigma_1, \tau'_1) \rightarrow_{\text{Inc}} (\sigma_2, \tau'_2) \rightarrow_{\text{Inc}} \dots \rightarrow_{\text{Inc}} (\sigma_n, \tau'_n)$  such that  $\tau'_n = \tau'$  and  $\tau_0 \sqsubseteq \tau'_0$ .

Note that if we have  $\tau_0 \sqsubset \tau'_0$ , and have the run above in the incremental semantics, then we also have a run  $(\sigma_0, \tau_0) \xrightarrow{\text{Inc}}^* (\sigma_n, \tau'_n)$ . This can be seen as follows. If there is no transaction having a write event in the run from  $(\sigma_0, \tau'_0)$ , then no  $\mathbf{co}$  edges get added in the sequence, so in this case we can assume  $\tau'_0 = \tau_0$  and  $\tau'_n = \tau_n$ , and they are total vacuously. If we encounter write transitions in some transactions in the sequence, then, even if we begin with  $\tau'_0 = \tau_0$ , we can make total, the  $\mathbf{co}$  edges whenever write transitions happen, and reach  $\tau'_n$ . Since  $\tau'_0$  and  $\tau_0$  differ only in the  $\mathbf{co}$  edges, the run starting with  $(\sigma_0, \tau_0)$  can “catch up” with the run starting from  $(\sigma_0, \tau'_0)$  and reach  $\tau'_n$ .

Thus, we obtain the run  $(\sigma_0, \tau_0) \xrightarrow{\text{Inc}}^* (\sigma_n, \tau')$ , and hence,  $\tau' \in [[\sigma]]_{\text{CCv}}^{\text{Inc}}$ .  $\square$

From Lemma E.1 and Lemma F.6, we obtain

LEMMA F.7.  $\{weak(\tau)|\tau \in [[\sigma]]_{CCV}^{ful}\} \subseteq \{weak(\tau)|\tau \in [[\sigma]]_{CCV}\}$

F.3  $\{weak(\tau)|\tau \in [[\sigma]]_{CCV}^{ful}\} \supseteq \{weak(\tau)|\tau \in [[\sigma]]_{CCV}\}$

LEMMA F.8. Given  $\tau_1 = \langle \mathcal{T}_1, po_1, rf_1, co_1 \rangle$ ,  $\tau_2 = \langle \mathcal{T}_2, po_2, rf_2, co_2 \rangle$ , with  $(\sigma, \tau_1) \rightarrow_{Inc} (\sigma', \tau_2)$  and  $\tau_2 \models CCV$ , then  $\tau_1 \models CCV$ .

PROOF. By definition of  $\rightarrow_{Inc}$ , we know  $\mathcal{T}_1 \subseteq \mathcal{T}_2$ ,  $po_1 \subseteq po_2$ ,  $rf_1 \subseteq rf_2$ , and  $co_1 \subseteq co_2$ . Since  $\tau_2 \models CCV$ , it follows that  $[po_1 \cup rf_1 \cup co_1]^+$  is acyclic and the other two conditions are also true for  $\tau_1$ . □

LEMMA F.9. Given  $\tau_1 = \langle \mathcal{T}_1, po_1, rf_1, co_1 \rangle$ ,  $\tau_2 = \langle \mathcal{T}_2, po_2, rf_2, co_2 \rangle$ ,

with  $(\sigma, \tau_1) \xrightarrow{(read,t,t')}_{Inc} (\sigma', \tau_2)$ , reading an event  $ev = r(p, t, x, v)$ , and  $\tau_2 \models CCV$ , then  $t' \in readable(\tau_1, t, x)$ .

PROOF. From the definition of  $\xrightarrow{(read,t,t')}_{Inc}$ , we know  $\mathcal{T}_1 = \mathcal{T}_2$ ,  $po_2 = po_1$ ,  $rf_2 = rf_1 \cup t'[rf]t$ ,  $co_2 \supseteq co_1$ .  $\tau_1$  and  $\tau_2$  are total. Assume  $t' \notin readable(\tau_1, t, x)$ . By the definition of readable sets,  $t' \notin readable(\tau_1, t, x)$  implies  $cond1 \vee cond2 \vee cond3 \vee cond4$ . Using lemmas from section C, we know that  $cond1 \vee cond2 \vee cond3 \vee cond4$  iff  $[po_2 \cup rf_2 \cup co_2]^+$  is cyclic, contradicting  $\tau_2 \models CCV$ . □

LEMMA F.10. If  $\tau \sqsubseteq \tau'$  then  $readable(\tau', t, x) \subseteq readable(\tau, t, x)$ .

PROOF. If  $t' \in readable(\tau', t, x)$ , then by lemmas from section C, we know that  $\neg cond1 \wedge \neg cond2 \wedge \neg cond3 \wedge \neg cond4$ . Since each  $cond$  represents a  $[po_2 \cup rf_2 \cup co_2]^+$  cycle, and  $\tau \sqsubseteq \tau'$ , the acyclicity of  $\tau \sqsubseteq \tau'$  implies that of  $[po_1 \cup rf_1 \cup co_1]^+$ . Thus,  $\neg cond1 \wedge \neg cond2 \wedge \neg cond3 \wedge \neg cond4$  also hold good for  $\tau$  and hence  $t' \in readable(\tau, t, x)$ . □

LEMMA F.11. If  $(\sigma, \tau_1) \xrightarrow{(begin,t)}_{Inc} (\sigma', \tau_2)$ , and  $\tau_3 \sqsubseteq \tau_1$ , then there exists a  $\tau_4$  such that  $(\sigma, \tau_3) \xrightarrow{(begin,t)}_{ful} (\sigma', \tau_4)$  and  $\tau_4 \sqsubseteq \tau_2$ .

PROOF. Let  $\tau_1 = \langle \mathcal{T}_1, po_1, rf_1, co_1 \rangle$ ,  $\tau_2 = \langle \mathcal{T}_2, po_2, rf_2, co_2 \rangle$ , and  $\tau_3 = \langle \mathcal{T}_3, po_3, rf_3, co_3 \rangle$ . By definition of  $\xrightarrow{(begin,t)}_{Inc}$ , we have  $\mathcal{T}_2 = \mathcal{T}_1 \cup \{t\}$ ,  $po_2 = po_1 \cup \{(t', t) \mid t' \text{ is the last transaction executed before } t \text{ in some process } p\}$ ,  $rf_2 = rf_1$ , and  $co_2 = co_1$ , and  $co_2$  is total. Since  $\tau_3 \sqsubseteq \tau_1$  it follows that  $\mathcal{T}_3 = \mathcal{T}_1$ ,  $po_3 = po_1$ ,  $rf_3 = rf_1$ , and  $co_3 \subseteq co_1$ .

Define  $\tau_4 = \langle \mathcal{T}_4, po_4, rf_4, co_4 \rangle$  such that  $\mathcal{T}_4 = \mathcal{T}_3 \cup \{t\}$ ,  $po_4 = po_3 \cup \{(t', t) \mid t' \text{ is the last transaction executed before } t \text{ in some process } p\}$ ,  $rf_4 = rf_3$ ,  $co_4 = co_3$ . It follows that  $\tau_3 \xrightarrow{t}_{ful} \tau_4$ . We need to show that  $co_4 \subseteq co_2$ . Since  $co_1 = co_2$ ,  $co_3 \subseteq co_1$  and  $co_4 = co_3$ , we get  $co_4 \subseteq co_2$ . □

LEMMA F.12. If  $(\sigma, \tau_1) \xrightarrow{(write,t)}_{Inc} (\sigma', \tau_2)$ , and  $\tau_3 \sqsubseteq \tau_1$ , then there exists a  $\tau_4$  such that  $(\sigma, \tau_3) \xrightarrow{(write,t)}_{ful} (\sigma', \tau_4)$  and  $\tau_4 \sqsubseteq \tau_2$ .

PROOF. Let  $\tau_1 = \langle \mathcal{T}_1, po_1, rf_1, co_1 \rangle$ ,  $\tau_2 = \langle \mathcal{T}_2, po_2, rf_2, co_2 \rangle$ , and  $\tau_3 = \langle \mathcal{T}_3, po_3, rf_3, co_3 \rangle$ . By definition of  $\xrightarrow{(write,t)}_{Inc}$ , we have  $\mathcal{T}_2 = \mathcal{T}_1$ ,  $po_2 = po_1$ ,  $rf_2 = rf_1$ , and  $co_2 \supseteq co_1$ , and  $co_2$  is total. Since  $\tau_3 \sqsubseteq \tau_1$  it follows that  $\mathcal{T}_3 = \mathcal{T}_1$ ,  $po_3 = po_1$ ,  $rf_3 = rf_1$ , and  $co_3 \subseteq co_1$ .

Define  $\tau_4 = \langle \mathcal{T}_4, po_4, rf_4, co_4 \rangle$  such that  $\mathcal{T}_4 = \mathcal{T}_3$ ,  $po_4 = po_3$ ,  $rf_4 = rf_3$ ,  $co_4 = co_3$ . It follows that  $\tau_3 \xrightarrow{(write,t)}_{ful} \tau_4$ . Since  $co_1 \subseteq co_2$ ,  $co_3 \subseteq co_1$  and  $co_4 = co_3$ , we get  $co_4 \subseteq co_2$ . □

LEMMA F.13. If  $(\sigma, \tau_1) \xrightarrow{(end,t)}_{\text{Inc}} (\sigma', \tau_2)$ , and  $\tau_3 \sqsubseteq \tau_1$ , then there exists a  $\tau_4$  such that  $(\sigma, \tau_3) \xrightarrow{(end,t)}_{\text{ful}} (\sigma', \tau_4)$  and  $\tau_4 \sqsubseteq \tau_2$ .

PROOF. The proof follows trivially since  $\sigma = \sigma'$  and  $\tau_1 = \tau_2$ . Choosing  $\tau_3 = \tau_1$  and  $\tau_4 = \tau_2$ , we have the result.  $\square$

LEMMA F.14. If  $(\sigma, \tau_1) \xrightarrow{(read,t,t')}_{\text{Inc}} (\sigma', \tau_2)$ ,  $\tau_3 \sqsubseteq \tau_1$ , and  $\tau_2 \models \text{CCv}$  then there exists a  $\tau_4$  such that  $(\sigma, \tau_3) \xrightarrow{(read,t,t')}_{\text{ful}} (\sigma', \tau_4)$  and  $\tau_4 \sqsubseteq \tau_2$ .

PROOF. Let  $\tau_1 = \langle \mathcal{T}_1, \text{po}_1, \text{rf}_1, \text{co}_1 \rangle$ ,  $\tau_2 = \langle \mathcal{T}_2, \text{po}_2, \text{rf}_2, \text{co}_2 \rangle$ , and  $\tau_3 = \langle \mathcal{T}_3, \text{po}_3, \text{rf}_3, \text{co}_3 \rangle$ . By definition of  $\xrightarrow{(read,t,t')}_{\text{Inc}}$ , we have a read event  $ev = r(p, t, x, v)$ . Also,  $\mathcal{T}_2 = \mathcal{T}_1$ ,  $\text{po}_2 = \text{po}_1$ ,  $\text{rf}_2 = \text{rf}_1 \cup t'[\text{rf}]t$ ,  $\text{co}_2 \supseteq \text{co}_1$ , and  $\tau_2$  is total. Since  $\tau_3 \sqsubseteq \tau_1$  it follows that  $\mathcal{T}_3 = \mathcal{T}_1$ ,  $\text{po}_3 = \text{po}_1$ ,  $\text{rf}_3 = \text{rf}_1$ , and  $\text{co}_3 \subseteq \text{co}_1$ .

Define  $\tau_4 = \langle \mathcal{T}_4, \text{po}_4, \text{rf}_4, \text{co}_4 \rangle$  such that  $\mathcal{T}_4 = \mathcal{T}_3$ ,  $\text{po}_4 = \text{po}_3$ ,  $\text{rf}_4 = \text{rf}_3 \cup t'[\text{rf}]t$ ,  $\text{co}_4 = \text{co}_3 \cup \text{co}'_3$ , where  $\text{co}'_3 = \text{co}_3 \cup \{t''[\text{co}]t' \mid t'' \in \text{visible}(\tau_3, t, x)\}$ , and if  $\exists t_2 [\text{rf}_1]^y t$ , and  $t' \in \mathcal{T}^{w,y}$ , then  $\text{co}'_3 = \text{co}_3 \cup t'[\text{co}]t_2$ . From Lemmas F.9, F.10 it follows that  $t' \in \text{readable}(\tau_3, t, x)$ , since  $t' \in \text{readable}(\tau_1, t, x)$  and  $\tau_3 \sqsubseteq \tau_1$ . Hence we have  $\tau_3 \xrightarrow{(read,t,t')}_{\text{Inc}} \tau_4$ . We need to show that  $\text{co}_4 \subseteq \text{co}_2$ . Assume  $t_1 \text{co}_4 t_2$ . We consider the following cases:

- $t_1 \text{co}_3 t_2$ . Since  $\text{co}_3 \subseteq \text{co}_1$ , it follows that  $t_1 \text{co}_1 t_2$ . It follows that  $t_1 \text{co}_2 t_2$ .
- $t_2 = t'$  and  $t_1 \in \text{visible}(\tau_3, t, x)$ . Since  $t_1 \in \text{visible}(\tau_3, t, x)$ , we have  $t_1 [\text{po}_3 \cup \text{rf}_3]^+ t$ , and hence  $t_1 [\text{po}_1 \cup \text{rf}_1]^+ t$ . It follows that  $t_1 [\text{po}_2 \cup \text{rf}_2]^+ t$ . Since  $\tau_2 \models \text{CCv}$  and  $t'[\text{rf}_2^x]t$ , we get  $t_1 [\text{co}_2]t'$ .
- $t_1 = t'$  and  $t_2 [\text{rf}_3^y]t$  and  $t' \in \mathcal{T}^{w,y}$ . Since  $\tau_3 \sqsubseteq \tau_1$  and  $(\sigma, \tau_1) \xrightarrow{(read,t,t')}_{\text{Inc}} (\sigma', \tau_2)$ , it follows that  $t_2 [\text{rf}_1^y]t$  and  $t_2 [\text{rf}_2^y]t$ . Since  $t_2 [\text{rf}_2^y]t$ , and  $t$  reads from  $t'$  (hence  $t' [\text{po}_2 \cup \text{rf}_2]^+ t$ ), and  $\tau_2 \models \text{CCv}$ , we get  $t' [\text{co}_2]t_2$ , i.e.  $t_1 [\text{co}_2]t_2$ .

$\square$

LEMMA F.15.  $\{\text{weak}(\tau) \mid \tau \in [[\sigma]]_{\text{CCv}}^{\text{Inc}}\} \subseteq \{\text{weak}(\tau) \mid \tau \in [[\sigma]]_{\text{CCv}}^{\text{ful}}\}$  for any configuration  $\sigma$ .

PROOF. Suppose  $\tau \in [[\sigma]]_{\text{CCv}}^{\text{Inc}}$ . We show that there is a trace  $\tau' \in [[\sigma]]_{\text{CCv}}^{\text{ful}}$  s.t.  $\tau' \sqsubseteq \tau$ . Then the result follows immediately.

Since  $\tau \in [[\sigma]]_{\text{CCv}}^{\text{Inc}}$ , it follows that  $\tau \models \text{CCv}$  and that  $(\sigma, \tau_0) \xrightarrow{*}_{\text{Inc}} (\sigma', \tau)$  for some configuration  $\sigma'$ . That is, there is a sequence  $(\sigma_0, \tau_0 \rightarrow_{\text{Inc}} (\sigma_1, \tau_1) \rightarrow_{\text{Inc}} \dots \rightarrow_{\text{Inc}} (\sigma_n, \tau_n)$  where  $\sigma_0 = \sigma, \tau_0 = \tau_0, \sigma_n = \sigma, \tau_n = \tau$ . By Lemma F.8, we know that  $\tau_i \models \text{CCv}$  for all  $1 \leq i \leq n$ . By Lemmas F.11, F.12, F.13, F.14, it follows that there is a sequence  $(\sigma_0, \tau'_0) \rightarrow_{\text{ful}} (\sigma_1, \tau'_1) \rightarrow_{\text{ful}} \dots \rightarrow_{\text{ful}} (\sigma_n, \tau'_n)$  with  $\tau'_0 = \tau_0$  and  $\tau'_i \sqsubseteq \tau_i$  for  $1 \leq i \leq n$ . Define  $\tau' = \tau'_n$ .

$\square$

From Lemma E.1 and Lemma F.15 we obtain

LEMMA F.16.  $\{\text{weak}(\tau) \mid \tau \in [[\sigma]]_{\text{CCv}}^{\text{ful}}\} \supseteq \{\text{weak}(\tau) \mid \tau \in [[\sigma]]_{\text{CCv}}\}$ .

## G COMPLETENESS

In this section, we show the completeness of the DPOR algorithm. More precisely, for any configuration  $\sigma$ , terminating run  $\rho \in \text{ExecFrom}(\sigma)$  and total trace  $\tau$  s.t.  $\tau \models \rho$ , we show that  $\text{ExploreTraces}(\sigma, \tau_0, \epsilon)$  will produce a recursive visit  $\text{ExploreTraces}(\sigma', \tau', \pi)$  for some terminal  $\sigma', \tau'$ , and  $\pi$  where  $\text{weak}(\tau') = \text{weak}(\tau)$ . First we give some definitions and auxiliary lemmas.

Let  $\pi = \alpha_{t_1} \alpha_{t_2} \dots \alpha_{t_n}$  be an observation sequence where  $\alpha_t = \text{begin}(p, t) \dots \text{end}(p, t)$ .  $\alpha_t$  is called an *observable*, and is a sequence of events from transaction  $t$ . Given  $\pi$ , a configuration  $\sigma$ , and a trace



$\tau$ , we define  $\langle \sigma, \tau \rangle \vdash_G \pi$  to represent a sequence  $\langle \sigma_0, \tau_0 \rangle \xrightarrow{\alpha_{t_1}}_{\text{ful}} \langle \sigma_1, \tau_1 \rangle \xrightarrow{\alpha_{t_2}}_{\text{ful}} \cdots \xrightarrow{\alpha_{t_n}}_{\text{ful}} \langle \sigma_n, \tau_n \rangle$ , where  $\sigma_0 = \sigma$ ,  $\tau_0 = \tau$  and  $\pi = \alpha_{t_1} \alpha_{t_2} \dots \alpha_{t_n}$ . Moreover, we define  $\pi(\sigma, \tau) := \langle \sigma_n, \tau_n \rangle$ . We define  $\tau \vdash_G \pi$  in similar manner, when there exists some  $\sigma$  s.t.  $(\sigma, \tau) \vdash_G \pi$ .

$\langle \sigma, \tau \rangle$  is *terminal* if  $\sigma$  is terminal. We define  $\langle \sigma, \tau \rangle \vdash_{G_T} \pi$  to say that (i)  $\langle \sigma, \tau \rangle \vdash_G \pi$  and (ii)  $\pi(\sigma, \tau)$  is terminal.

**Definition G.1.** (*p-free and t-free observation sequences*) For a process  $p \in P$ , we say that an observation sequence  $\pi$  is *p-free* if all observables  $\alpha_t$  in  $\pi$  pertain to transactions  $t$  not in  $p$ . For a transaction  $t$  issued in  $p$  we say that  $\pi$  is *t-free* if  $\pi$  is *p-free*.

**Definition G.2.** (*Independent Observables*) For observables  $\alpha_{t_1}$  and  $\alpha_{t_2}$ , we write  $\alpha_{t_1} \sim \alpha_{t_2}$  to represent they are independent. This means (i)  $t_1, t_2$  are transactions issued in different processes, that is,  $t_1$  is issued in  $p_1$ ,  $t_2$  is issued in  $p_2$ , with  $p_1 \neq p_2$ , (ii) no read event  $r(p_2, t_2, x, v)$  of transaction  $t_2$  reads from  $t_1$ , and (iii) no read event  $r(p_1, t_1, x, v)$  of transaction  $t_1$  reads from  $t_2$ . Thus,  $\neg(\alpha_{t_1} \sim \alpha_{t_2})$  if either  $t_1, t_2$  are issued in the same process, or there is a *rf* relation between  $t_1, t_2$ . That is,  $\neg(\alpha_{t_1} \sim \alpha_{t_2})$  iff  $t_1 [po \cup rf]^+ t_2$  or  $t_2 [po \cup rf]^+ t_1$ .

**Definition G.3.** (*Independent Observation Sequences*) Observation sequences  $\pi^1, \pi^2$  are called independent written  $\pi^1 \sim \pi^2$  if there are observables  $\alpha_{t_1}, \alpha_{t_2}$ , and observation sequences  $\pi'$  and  $\pi''$  such that  $\pi^1 = \pi' \cdot \alpha_{t_1} \cdot \alpha_{t_2} \cdot \pi''$ ,  $\pi^2 = \pi' \cdot \alpha_{t_2} \cdot \alpha_{t_1} \cdot \pi''$ , and  $\alpha_{t_1} \sim \alpha_{t_2}$ . In other words, we get  $\pi^2$  from  $\pi^1$  by swapping neighbouring independent observables corresponding to transactions  $t_1$  and  $t_2$ .

We use  $\approx$  to denote reflexive transitive closure of  $\sim$ .

**Definition G.4.** (*Equivalent Traces*) For traces  $\tau_1 = \langle \mathcal{T}_1, po_1, rf_1, co_1 \rangle$  and  $\tau_2 = \langle \mathcal{T}_2, po_2, rf_2, co_2 \rangle$ , we say  $\tau_1, \tau_2$  are equivalent denoted  $\tau_1 \equiv \tau_2$  if  $\mathcal{T}_1 = \mathcal{T}_2$ ,  $po_1 = po_2$ ,  $rf_1 = rf_2$  and for all  $t_1, t_2 \in \mathcal{T}_1^{w,x}$  for all variables  $x$ , we have  $t_1 [po_1 \cup rf_1 \cup co_1^x] t_2$  iff  $t_1 [po_2 \cup rf_2 \cup co_2^x] t_2$ .

LEMMA G.5.  $((\tau_1 \equiv \tau_2) \wedge \tau_1 \vdash_G \alpha_t) \Rightarrow (\tau_2 \vdash_G \alpha_t \wedge (\alpha_t(\tau_1) \equiv \alpha_t(\tau_2)))$ .

PROOF. Assume  $\tau_1 \vdash_G \alpha_t$  for an observable  $\alpha_t$ , and  $\tau_1 = (\mathcal{T}_1, po_1, rf_1, co_1)$ ,  $\tau_2 = (\mathcal{T}_2, po_2, rf_2, co_2)$  with  $\tau_1 \equiv \tau_2$ . Then we know that  $\mathcal{T}_1 = \mathcal{T}_2$ ,  $po_1 = po_2$ ,  $rf_2 = rf_1$ .

Since  $\tau_1 \vdash_G \alpha_t$ , let  $\tau_1 \xrightarrow{\alpha_t}_{\text{ful}} \tau'$ .  $\tau' = (\mathcal{T}', po', rf', co')$  where  $\mathcal{T}' = \mathcal{T}_1 \cup \{t\}$ ,  $po' = po_1 \cup \{(t_1, t) \mid t_1 \in \mathcal{T}_1 \text{ is in the same process as } t\}$ ,  $co_1 \subseteq co'$  and  $rf_1 \subseteq rf'$ .  $co'$  can contain  $(t', t)$  for some  $t' \in \mathcal{T}_1$ , when  $t', t \in \mathcal{T}'^{w,x}$  for some variable  $x$ , based on the fulfilled semantics. In particular if we have  $t_1 rf'^x t_2$  and  $t_3 (rf' \cup po' \cup co'^x)^+ t_2$ , then  $t_3 co'^x t_1$ .

Since  $\tau_1 \equiv \tau_2$ , for any transactions  $t', t''$  in  $\mathcal{T}_1 = \mathcal{T}_2$ ,  $t' [po_1 \cup co_1^x \cup rf_1] t''$  iff  $t' [po_2 \cup co_2^x \cup rf_2] t''$  for all variables  $x$ . In particular,  $t' co_1^x t''$  iff  $t' co_2^x t''$  for all  $x$ . Now, let us construct a trace  $\tau'' = (\mathcal{T}', po'', rf'', co'')$ , where  $co''$  is the smallest set such that  $co_2 \subseteq co''$  and whenever  $t_1 rf'^x t_2$  and  $t_3 (rf' \cup po' \cup co'^x)^+ t_2$ , then  $t_3 co''^x t_1$ .

Since  $t' [po_1 \cup rf_1 \cup co_1^x] t''$  iff  $t' [po_2 \cup rf_2 \cup co_2^x] t''$  for all  $x$ , and all  $t', t'' \in \mathcal{T}_1 = \mathcal{T}_2$ , and  $co''$  is the smallest extension of  $co_2$  based on the fulfilled semantics, along with the fact that  $po' = po''$ ,  $rf' = rf''$ , we obtain for any two transactions  $t_1, t_2 \in \mathcal{T}' = \mathcal{T}''$ ,  $t_1 [po' \cup rf' \cup co'] t_2$  iff  $t_1 [po'' \cup rf'' \cup co''] t_2$ . This gives  $\tau' \equiv \tau''$ .

This also gives  $\tau_2 \xrightarrow{\alpha_t}_{\text{ful}} \tau''$ , that is,  $\tau_2 \vdash_G \alpha_t$  and indeed  $\alpha_t(\tau_1) = \tau' \equiv \tau'' = \alpha_t(\tau_2)$ . □

LEMMA G.6. *If  $\tau \vdash_G \alpha_{t_1} \cdot \alpha_{t_2}$  and  $\alpha_{t_1} \sim \alpha_{t_2}$  then  $\tau \vdash_G \alpha_{t_2} \cdot \alpha_{t_1}$  and  $(\alpha_{t_1} \cdot \alpha_{t_2})(\tau) \equiv (\alpha_{t_2} \cdot \alpha_{t_1})(\tau)$ .*

PROOF. Let  $\tau = \langle \mathcal{T}, po, rf, co \rangle$  be a trace and let  $t_1$  be a transaction issued in process  $p_1$ , and  $t_2$  be a transaction issued in process  $p_2$ , with  $p_1 \neq p_2$ . Assume  $\tau \vdash_G \alpha_{t_1} \cdot \alpha_{t_2}$ , with  $\alpha_{t_1} \sim \alpha_{t_2}$ .

We consider the following cases.

- $t_1, t_2 \notin \mathcal{T}^r$ . In this case  $\tau \vdash_G \alpha_{t_2} \cdot \alpha_{t_1}$  holds trivially.  
 $(\alpha_{t_1} \cdot \alpha_{t_2})(\tau) = (\alpha_{t_2} \cdot \alpha_{t_1})(\tau) = \langle \mathcal{T}', \mathbf{po}', \mathbf{rf}, \mathbf{co} \rangle$ , where  $\mathcal{T}' = \mathcal{T} \cup \{t_1, t_2\}$  and  $\mathbf{po}' = \mathbf{po} \cup \{(t, t_1) | t \in p_1\} \cup \{(t', t_2) | t' \in p_2\}$ .
- $t_1 \in \mathcal{T}^w$ ,  $t_1 \notin \mathcal{T}^r$  and  $t_2 \in \mathcal{T}^r \cap \mathcal{T}^w$ . Let  $\tau_1 = \alpha_{t_1}(\tau)$ . We know that  $\tau_1 = \langle \mathcal{T}_1, \mathbf{po}_1, \mathbf{rf}_1, \mathbf{co}_1 \rangle$ , where  $\mathcal{T}_1 = \mathcal{T} \cup \{t_1\}$ , and  $\mathbf{po}_1 = \mathbf{po} \cup \{(t, t_1) | t \in p_1\}$ , with  $\mathbf{rf}_1 = \mathbf{rf}$  since there are no read events in  $t_1$ , and  $\mathbf{co}_1 = \mathbf{co}$  since by the fulfilled semantics, when  $\mathbf{rf}$  remain same, there are no  $\mathbf{co}$  edges to be added.

Consider  $\tau_2 = \alpha_{t_2}(\tau_1) = \langle \mathcal{T}_2, \mathbf{po}_2, \mathbf{rf}_2, \mathbf{co}_2 \rangle$ . Since  $t_2 \in \mathcal{T}^r$ , we know that  $t_2$  has read events.

Let there be  $n$  read events  $ev_1 \dots ev_n$  in transaction  $t_2$ , reading from transactions  $t'_1, \dots, t'_n$  on variables  $x_1, \dots, x_n$ . Hence we get a sequence  $\tau_1 \xrightarrow{(begin, t_2)}_{\text{ful}} \dots \tau'_{i_1} \xrightarrow{(read, t_2, t'_1)}_{\text{ful}} \tau_{i_1} \xrightarrow{\text{ful}} \dots \tau'_{i_n} \xrightarrow{(read, t_2, t'_n)}_{\text{ful}} \tau_{i_n} \dots \xrightarrow{(end, t_2)}_{\text{ful}} \tau_2$ . Hence  $\mathcal{T}_2 = \mathcal{T}_1 \cup \{t_2\}$ ,  $\mathbf{po}_2 = \mathbf{po}_1 \cup \{(t', t_2) | t' \in p_2\}$ ,  $\mathbf{rf}_2 = \mathbf{rf}_1 \cup (\mathbf{rf}_{i_1} \cup \mathbf{rf}_{i_2} \dots \cup \mathbf{rf}_{i_n})$ , and  $\mathbf{co}_2 = \mathbf{co}_1 \cup (\mathbf{co}_{i_1} \cup \mathbf{co}_{i_2} \dots \cup \mathbf{co}_{i_n})$ . Since  $\tau_1 \vdash_G \alpha_{t_2}$ , for all  $ev_i : 1 \leq i \leq n$ , we have  $t'_i \in \text{readable}(\tau_1, t_2, x_i)$ .

Since  $\alpha_{t_1} \sim \alpha_{t_2}$ , we know that for all  $ev_i : 1 \leq i \leq n$ , we have  $t'_i \in \text{readable}(\tau, t_2, x_i)$ . It follows that  $\tau \vdash_G \alpha_{t_2}$ . Define  $\tau_3 = \langle \mathcal{T}_3, \mathbf{po}_3, \mathbf{rf}_2, \mathbf{co}_2 \rangle$ , where  $\mathcal{T}_3 = \mathcal{T} \cup \{t_2\}$  and  $\mathbf{po}_3 = \mathbf{po} \cup \{(t', t_2) | t' \in p_2\}$ . It follows that  $\alpha_{t_2}(\tau) = \tau_3$ ,  $\tau_3 \vdash_G \alpha_{t_1}$  and  $\tau_2 = \alpha_{t_1}(\tau_3) = \alpha_{t_2}(\alpha_{t_1}(\tau))$ .

- $t_2 \in \mathcal{T}^w$  and  $t_1 \in \mathcal{T}^r \cap \mathcal{T}^w$ . Similar to previous case.
- $t_1, t_2 \in \mathcal{T}^r \cap \mathcal{T}^w$ . Let  $\tau_1 = \alpha_{t_1}(\tau) = \langle \mathcal{T}_1, \mathbf{po}_1, \mathbf{rf}_1, \mathbf{co}_1 \rangle$  and  $\tau_2 = \alpha_{t_2}(\tau_1)$ . Since  $t_1 \in \mathcal{T}^r$ , we know that  $t_1$  has read events. Let there be  $n$  read events  $ev_1 \dots ev_n$  in transaction  $t_1$ , reading from transactions  $t'_1, \dots, t'_n$  on variables  $x_1, \dots, x_n$ . Hence we get the sequence  $\tau \xrightarrow{(begin, t_1)}_{\text{ful}} \dots \tau'_{i_1} \xrightarrow{(read, t_1, t'_1)}_{\text{ful}} \tau_{i_1} \xrightarrow{\text{ful}} \dots \tau'_{i_n} \xrightarrow{(read, t_1, t'_n)}_{\text{ful}} \tau_{i_n} \dots \xrightarrow{(end, t_1)}_{\text{ful}} \tau_1$ . Since  $t_2 \in \mathcal{T}^r$ , we know that  $t_2$  has read events. Let there be  $m$  read events  $ev'_1 \dots ev'_m$  in transaction  $t_2$ , reading from transactions  $t''_1, \dots, t''_m$  on variables  $y_1, \dots, y_m$ . Then we get the sequence  $\tau_1 \xrightarrow{(begin, t_2)}_{\text{ful}} \dots \tau'_{j_1} \xrightarrow{(read, t_2, t''_1)}_{\text{ful}} \tau_{j_1} \xrightarrow{\text{ful}} \dots \tau'_{j_n} \xrightarrow{(read, t_2, t''_n)}_{\text{ful}} \tau_{j_n} \dots \xrightarrow{(end, t_2)}_{\text{ful}} \tau_2$ .

Proving  $\tau \vdash_G \alpha_{t_2} \cdot \alpha_{t_1}$

Since  $\tau_1 = \alpha_{t_1}(\tau)$ , for all read events  $ev_i$  such that  $ev_i.trans = t_1$ , we have  $t'_i \in \text{readable}(\tau, t_1, x_i)$ .

Since  $\tau_2 = \alpha_{t_2}(\tau_1)$ , for all read events  $ev'_j$  such that  $ev'_j.trans = t_2$ , we have  $t''_j \in \text{readable}(\tau_1, t_2, y_j)$ .

Since  $\alpha_{t_1} \sim \alpha_{t_2}$ , it follows that, we have  $t''_j \in \text{readable}(\tau, t_2, y_j)$  for all read events  $ev'_j$  such that  $ev'_j.trans = t_2$ . Hence  $\tau \vdash_G \alpha_{t_2}$ .

Consider  $\tau_3 = \alpha_{t_2}(\tau) = \langle \mathcal{T}_3, \mathbf{po}_3, \mathbf{rf}_3, \mathbf{co}_3 \rangle$ . To show that  $\tau \vdash_G \alpha_{t_2} \alpha_{t_1}$ , we show that for all read events  $ev_i$  such that  $ev_i.trans = t_1$ ,  $t'_i \in \text{readable}(\tau_3, t_1, x_i)$ . We prove this using contradiction. Assume that  $\exists t'_i$  s.t.  $t'_i \notin \text{readable}(\tau_3, t_1, x_i)$ .

If  $t'_i \notin \text{readable}(\tau_3, t_1, x_i)$ , then there is a  $t'_k$  such that (i)  $t'_k \in \text{visible}(\tau_3, t_1, x_i)$  and (ii)  $t'_i [po_3 \cup rf_3 \cup co_3]^+ t'_k$ .

If (i) is true, that is,  $t'_k \in \text{visible}(\tau_3, t_1, x_i)$ , since  $\alpha_{t_1} \sim \alpha_{t_2}$ , we also have  $t'_k \in \text{visible}(\tau, t_1, x_i)$ . This, combined with  $t'_i \in \text{readable}(\tau, t_1, x_i)$ , gives according to the fulfilled semantics,  $t'_k [co_1] t'_i$ . Going back to (ii), we can have  $t'_i [po_3 \cup rf_3 \cup co_3]^+ t'_k$  only if we observed one of the following:

- There is a path from  $t'_i$  to  $t'_k$  in  $\tau$ ; that is,  $t'_i [po \cup rf \cup co]^+ t'_k$ . This implies that  $t'_i \notin \text{readable}(\tau, t_1, x_i)$  which is a contradiction.
- There is no direct path from  $t'_i$  to  $t'_k$ , however, there are transactions  $t''_j, t''_k$  such that, in  $\tau$  we had  $t''_j [po \cup rf \cup co]^* t'_k$  and  $t'_i [po \cup rf \cup co]^* t''_k$ , along with  $t''_j \in \text{readable}(\tau, t_2, y_j)$ ,

$t_l'' \in \text{visible}(\tau, t_2, y_j)$ . Let  $ev'_j = r(p_2, t_2, y_j, v)$  be the read event which reads from  $t_l''$ , justifying  $t_l'' \in \text{readable}(\tau, t_2, y_j)$ .

Since  $t_j''[po \cup rf \cup co]^* t_k'$  and  $t_i'[po \cup rf \cup co]^* t_l''$  it follows that  $t_j''[po_1 \cup rf_1 \cup co_1]^* t_k'$ ,  $t_i'[po_1 \cup rf_1 \cup co_1]^* t_l''$ . By our assumption, we have  $t_i' \in \text{readable}(\tau, t_1, x_i)$  and  $t_k' \in \text{visible}(\tau, t_1, x_i)$ , which gives us  $t_k'[\text{co}_1^{x_i}]t_i'$  (already observed in the para before (i)).

Thus we get  $t_j''[po_1 \cup rf_1 \cup co_1]^* t_k'[\text{co}_1^{x_i}]t_i'[po_1 \cup rf_1 \cup co_1]^* t_l''$ , which gives  $t_j''[po_1 \cup rf_1 \cup co_1]^+ t_l''$ . Hence  $t_j'' \notin \text{readable}(\tau_1, t_2, y_j)$ , a contradiction.

Thus, we have  $\neg(t_i'[po_3 \cup rf_3 \cup co_3]^+ t_k')$ . This, for all  $1 \leq i \leq n$ ,  $t_i' \in \text{readable}(\tau_3, t_1, x_i)$ .

Thus, we now have  $\tau \vdash_G \alpha_{t_2} \alpha_{t_1}$ . It remains to show that  $(\alpha_{t_1} \cdot \alpha_{t_2})(\tau) \equiv (\alpha_{t_2} \cdot \alpha_{t_1})(\tau)$ .

Proving  $(\alpha_{t_1} \cdot \alpha_{t_2})(\tau) \equiv (\alpha_{t_2} \cdot \alpha_{t_1})(\tau)$

Define  $\tau_4 = \alpha_{t_1}(\tau_3) = \alpha_{t_1} \cdot \alpha_{t_2}(\tau) = \langle \mathcal{T}_4, po_4, rf_4, co_4 \rangle$ . Recall that  $\tau_2 = \alpha_{t_2} \cdot \alpha_{t_1}(\tau) = \langle \mathcal{T}_2, po_2, rf_2, co_2 \rangle$ .

To show that  $(\alpha_{t_1} \cdot \alpha_{t_2})(\tau) \equiv (\alpha_{t_2} \cdot \alpha_{t_1})(\tau)$ , we show that  $\mathcal{T}_2 = \mathcal{T}_4$ ,  $po_2 = po_4$ ,  $rf_2 = rf_4$ , and, for any two transactions  $t'_k, t'_i \in \mathcal{T}_2 = \mathcal{T}_4$ ,  $t'_k[po_2 \cup rf_2 \cup co_2]^+ t'_i$  iff  $t'_k[po_4 \cup rf_4 \cup co_4]^+ t'_i$ . Of these, trivially,  $\mathcal{T}_2 = \mathcal{T}_4$ ,  $po_2 = po_4$  follow. Since  $\alpha_{t_2} \sim \alpha_{t_1}$ , we have  $rf_2 = rf_4$ . It remains to prove the last condition.

Assume that  $t_i'[rf_1^{x_i}]t_1 \wedge t'_k \in \text{visible}(\tau_1, t_1, x_i)$ , where  $\tau_1 = \alpha_{t_1}(\tau)$ . Then we have  $t_i'[rf_1^{x_i}]t_1 \wedge t'_k \in \text{visible}(\tau, t_1, x_i)$ , and by the fulfilled semantics, we have  $t'_k[co_1]t_i'$ , and hence  $t'_k[co_2]t_i'$ . To obtain  $\tau_4$ , we execute  $t_2$  first obtaining  $\tau_3$  from  $\tau$ , and then  $t_1$ . We show that  $t'_k[po_4 \cup rf_4 \cup co_4]^+ t'_i$ , proving  $t'_k[po_2 \cup rf_2 \cup co_2]^+ t'_i \Rightarrow t'_k[po_4 \cup rf_4 \cup co_4]^+ t'_i$ .

If we have  $t'_k \in \text{visible}(\tau_3, t_1, x_i)$ , then we are done since we have  $t'_i \in \text{readable}(\tau, t_1, x_i)$ , hence  $t'_i \in \text{readable}(\tau_3, t_1, x_i)$ , thereby obtaining  $t'_k co_3 t'_i$ , and hence  $t'_k co_4 t'_i$ .

Assume  $t'_k \notin \text{visible}(\tau_3, t_1, x_i)$ . Assume that on executing  $t_2$  from  $\tau$ , we have  $t_l'' \in \text{visible}(\tau, t_2, y_j)$ , and let  $t_j''[rf_3^{y_j}]t_2$ . Then by the fulfilled semantics,  $t_l''[co_3]t_j''$  is a new edge which gets added. When we execute  $t_1$  next, assume  $t_m'' \in \text{visible}(\tau_3, t_1, x_i)$ . Since we have  $t'_i \in \text{readable}(\tau_3, t_1, x_i)$ , we obtain  $t_m'' co_4 t'_i$ .

By assumption,  $t'_k \neq t_m''$ . However,  $t'_k \in \text{visible}(\tau, t_1, x_i)$ .

$t'_k \notin \text{visible}(\tau_3, t_1, x_i)$  points to another transaction that blocked the visibility of  $t'_k$  in  $\tau_3$ , by happening after  $t'_k$ , and which is in  $\text{visible}(\tau_3, t_1, x_i)$ .

- (1) This blocking transaction could be  $t_m''$ . If this is the case, we have  $t'_k[po_3 \cup rf_3 \cup co_3]^+ t_m''[co_4]t'_i$ , and hence  $t'_k[po_4 \cup rf_4 \cup co_4]^+ t_m''[co_4]t'_i$ .
- (2) The other possibility is that we have  $t_j''$  happens before  $t_m''$ , and  $t_l''$  happens after  $t'_k$  blocking  $t'_k$  from being in  $\text{visible}(\tau_3, t_1, x_i)$ . That is,  $t'_k[po \cup rf \cup co]^* t_l''$  and  $t_j''[po_4 \cup rf_4 \cup co_4]^* t_m''$ . Then we obtain  $t'_k[po_4 \cup rf_4 \cup co_4]^* t_l''[co_4^{x_j}]t_j''[po_4 \cup rf_4 \cup co_4]^* t_m''[co_4]t'_i$ .

Thus, we obtain  $t'_k[po_4 \cup rf_4 \cup co_4]^+ t'_i$  as desired.

The converse direction, that is, whenever  $t'_k[po_4 \cup rf_4 \cup co_4]^+ t'_i$ , we also have  $t'_k[po_2 \cup rf_2 \cup co_2]^+ t'_i$  is proved on similar lines. □

LEMMA G.7. *If  $\tau_1 \equiv \tau_2$ ,  $\alpha_{t_1} \sim \alpha_{t_2}$ , and  $\tau_1 \vdash_G (\alpha_{t_1} \cdot \alpha_{t_2})$ , then (i)  $\tau_2 \vdash_G (\alpha_{t_2} \cdot \alpha_{t_1})$  and (ii)  $(\alpha_{t_1} \cdot \alpha_{t_2})(\tau_1) \equiv (\alpha_{t_2} \cdot \alpha_{t_1})(\tau_2)$ .*

PROOF. Follows from Lemma G.5 and Lemma G.6. □

From Lemma G.7, we get following lemma.

LEMMA G.8. *If  $\tau_1 \equiv \tau_2$ ,  $\pi_{T^1} \sim \pi_{T^2}$ , and  $\tau_1 \vdash_G \pi_{T^1}$  then  $\tau_2 \vdash_G \pi_{T^2}$  and  $\pi_{T^1}(\tau_1) \equiv \pi_{T^2}(\tau_2)$ .*

LEMMA G.9. If  $\langle \sigma, \tau \rangle \vdash_{G_T} \pi_T$ ,  $\langle \sigma, \tau \rangle \vdash_G \alpha_t$  then  $\pi_T = \pi_{T^1} \cdot \alpha_t \cdot \pi_{T^2}$  for some  $\pi_{T^1}$  and  $\pi_{T^2}$  where  $\pi_{T^1}$  is  $t$ -free.

Consider observables  $\pi_T = \alpha_{t_1} \alpha_{t_2} \dots \alpha_{t_n}$ . We write  $\pi_T \lesssim \pi'_T$  to represent that  $\pi'_T = \pi_{T^0} \cdot \alpha_{t_1} \cdot \pi_{T^1} \cdot \alpha_{t_2} \cdot \pi_{T^2} \dots \alpha_{t_n} \cdot \pi_{T^n}$ . In other words,  $\pi_T$  occurs as a non-contiguous subsequence in  $\pi'_T$ . For such a  $\pi_T, \pi'_T$ , we define  $\pi'_T \circ \pi_T := \pi_{T^0} \cdot \pi_{T^1} \dots \pi_{T^n}$ . Since elements of  $\pi_T$  and  $\pi'_T$  are distinct, operation  $\circ$  is well defined. Let  $\pi_T[i]$  denote the  $i$ th observable in the observation sequence  $\pi_T$ , and let  $|\pi_T|$  denote the number of observables in  $\pi_T$ .

Let  $\alpha_t = \pi_T[i]$  for some  $i : 1 \leq i \leq |\pi_T|$ . We define  $\text{Pre}(\pi_T, \alpha_t)$  as a subsequence  $\pi'_T$  of  $\pi_T$  such that (i)  $\alpha_t \in \pi'_T$ , (ii)  $\alpha_{t_j} = \pi_T[j] \in \pi'_T$  for some  $j : 1 \leq j < i$  iff there exists  $k : j < k \leq i$  such that  $\alpha_{t_k} = \pi_T[k] \in \pi'_T$  and  $\neg(\alpha_{t_j} \sim \alpha_{t_k})$ . Thus,  $\text{Pre}(\pi_T, \alpha_t)$  consists of  $\alpha_t$  and all  $\alpha_{t'}$  appearing before  $\alpha_t$  in  $\pi_T$  such that  $t' \ll [po \cup rf]^+ t$ .

LEMMA G.10. If  $\pi_{T^1} = \text{Pre}(\pi_T, \alpha_t)$  and  $\pi_{T^2} = \pi_T \circ \pi_{T^1}$  then  $\pi_T \approx \pi_{T^1} \cdot \pi_{T^2}$ .

PROOF. The proof is trivial since we can always execute in order, the  $[po \cup rf]^+$  predecessors of  $\alpha_t$  from  $\text{Pre}(\pi_T, \alpha_t)$ , then  $\alpha_t$ , then the observables in  $\text{Pre}(\pi_T, \alpha_t)$  which are independent from  $\alpha_t$ , followed by the suffix of  $\pi_T$  after  $\alpha_t$ . □

LEMMA G.11. If  $\pi_T = \pi'_T \cdot \pi''_T$  and  $\alpha_t \in \pi'_T$  then  $\text{Pre}(\pi_T, \alpha_t) = \text{Pre}(\pi'_T, \alpha_t)$ .

PROOF. The proof is trivial once again, since all the transactions which are  $[po \cup rf]^+ t$  are in the prefix  $\pi'_T$ . □

LEMMA G.12. If  $\langle \sigma, \tau \rangle \vdash_G \pi_T$  then  $\langle \sigma, \tau \rangle \vdash_{G_T} \pi_T \cdot \pi_{T^2}$ .

PROOF. This simply follows from the fact that we can extend the observation sequence  $\pi_T$  to obtain a terminal configuration, since the DPOR algorithm generates weak traces corresponding to terminating runs. □

LEMMA G.13. Consider a fulfilled trace  $\tau$  such that  $\tau \models \text{CCv}$ ,  $\tau \vdash_G \pi_T \cdot \alpha_t$ . Let each read event  $ev_i = r_i(p, t, x_i, v)$  in  $\alpha_t$  read from some transaction  $t_i$ , and let  $\pi_T$  be  $t$ -free. Then  $\tau \vdash_G \alpha'_t \cdot \pi_T$ , where  $\alpha'_t$  is the same as  $\alpha_t$ , with the exception that the sources of its read events can be different. That is, each read event  $ev_i = r_i(p, t, x_i, v) \in \alpha'_t$  can read from some transaction  $t'_i \neq t_i$ .

PROOF. Let  $\pi_T = \alpha_{t_1} \alpha_{t_2} \dots \alpha_{t_n}$  and  $\tau_0 \xrightarrow{\alpha_{t_1}}_{\text{ful}} \tau_1 \xrightarrow{\alpha_{t_2}}_{\text{ful}} \dots \xrightarrow{\alpha_{t_n}}_{\text{ful}} \tau_n \xrightarrow{\alpha_t}_{\text{ful}} \tau_{n+1}$ , where  $\tau_0 = \tau$ . Let  $\tau_i = \langle \mathcal{T}_i, po_i, rf_i, co_i \rangle$ . Let there be  $m$  read events in transaction  $t$ . Keeping in mind what we want to prove, where we want to execute  $t$  first followed by  $\pi_T$ , and obtain an execution  $\alpha'_t \pi_T$ , we do the following.

For each read event  $ev_i = r_i(p, t, x_i, v)$  we define  $t'_i \in \mathcal{T}^{w, x_i}$  such that (i)  $t'_i \in \text{readable}(\tau_0, t, x_i)$ , and (ii) there is no  $t''_i \in \text{readable}(\tau_0, t, x_i)$  where  $t'_i \ll [po_n \cup rf_n \cup co_n] t''_i$ . Note that this is possible since  $\pi_T$  is  $t$ -free, so all the observables  $\alpha_{t_i}$  occurring in  $\pi_T$  are such that  $t_i$  is issued in a process other than that of  $t$ . Thus, when  $\alpha_t$  is enabled, we can choose any of the writes done earlier, this fact is consistent with the CCv semantics, since from Lemmas C.1-C.4 we know  $\tau_n \models \text{CCv}$ . Since  $\tau_n \models \text{CCv}$  such a  $t'_i \in \text{readable}(\tau_0, t, x_i)$  exists for each  $ev_i$ .

Next we define a sequence of traces which can give the execution  $\alpha'_t \pi_T$ . Define a sequence of traces  $\tau'_0, \tau'_1, \dots, \tau'_n$  where  $\tau'_j = \langle \mathcal{T}'_j, po'_j, rf'_j, co'_j \rangle$  is such that

- (1)  $\tau \vdash_G \alpha'_t$  and  $\alpha'_t(\tau) = \tau'_0$ ,
  - (2)  $\tau'_j \vdash_G \alpha_{t_{j+1}}$  and  $\tau'_{j+1} = \alpha_{t_{j+1}}(\tau'_j)$  for all  $j : 0 \leq j \leq n$ .
- Define  $\mathcal{T}'_i = \mathcal{T}_i \cup \{t\}$  for all  $0 \leq i \leq n$ ,

- Define  $po' = \{t' [po] t \mid t' \text{ is a transaction in } \tau, \text{ in the same process as } t\}$ , and  $po'_i = po_i \cup po'$  for all  $0 \leq i \leq n$ ,
- $rf' = \bigcup_{i:1 \leq i \leq m} t'_i [rf^{x_i}] t$  (reads from relation corresponding to each read event  $ev_i \in \alpha'_i$ ), and  $rf'_i = rf_i \cup rf'$  for all  $i : 1 \leq i \leq n$ ,
- $co' = \bigcup_{j:1 \leq j \leq m} co'_j$  (each  $co'_j$  corresponds to the updated  $co$  relation because of the read transition  $\xrightarrow{(read, t, t'_j)}_{\text{ful}}$ ).

For  $1 \leq i \leq n$ , we define  $co'_i$  inductively as  $co'_i = co_i \cup co'$  and show that  $\tau'_i \vdash_G \alpha_{t_{i+1}}$  and  $\tau'_{i+1} = \alpha_{t_{i+1}}(\tau'_i)$  holds good. First define  $co'_0 = co_0 \cup co'$ . Then define  $co'_i$  to be the coherence order corresponding to  $\alpha_{t_i}(\tau'_{i-1})$  where  $\tau'_{i-1} = \langle \mathcal{T}'_{i-1}, po_{i-1}, rf_{i-1}, co_{i-1} \rangle$  for all  $i : 1 \leq i \leq n$ .

**Base case.** The base case  $\tau \vdash_G \alpha'_i$  and  $\alpha'_i(\tau) = \tau'_0$ , holds trivially, by construction.

**Inductive hypothesis.** Assume that  $\tau'_j \vdash_G \alpha_{t_{j+1}}$  and  $\tau'_{j+1} = \alpha_{t_{j+1}}(\tau'_j)$  for  $0 \leq j \leq i-1$ .

We have to prove that  $\tau'_i \vdash_G \alpha_{t_{i+1}}$  and  $\tau'_{i+1} = \alpha_{t_{i+1}}(\tau'_i)$ .

- (1) If  $t_{i+1} \in \mathcal{T}^w$  and  $t_{i+1} \notin \mathcal{T}^r$ , then the proof holds trivially from the inductive hypothesis.
- (2) Consider now  $t_{i+1} \in \mathcal{T}^r$ . Consider a read event  $ev^{i+1} = r(p, t_{i+1}, x, v) \in \alpha_{t_{i+1}}$  which was reading from transaction  $t_x$  in  $\pi_T$ . That is, we had  $t_x \in \text{readable}(\tau_i, t_{i+1}, x)$ . If  $t_x \in \text{readable}(\tau'_i, t_{i+1}, x)$ , then we are done, since we can simply extend the run from the inductive hypothesis.

Assume otherwise. That is,  $t_x \notin \text{readable}(\tau'_i, t_{i+1}, x)$ .

Since  $t_x \in \text{readable}(\tau_i, t_{i+1}, x)$ , we know that there are some blocking transactions in the new path which prevents  $t_x$  from being readable. Basically, we have the blocking transactions since  $t$  is moved before  $\pi_T$ .

- Consider  $tr_1 \in \text{visible}(\tau, t, y)$  for some variable  $y$  such that, in  $\pi_T. \alpha_t$ , we had  $t_x [po_i \cup rf_i \cup co_i]^* tr_1$ . This path is possible since  $\alpha_t$  comes last in in  $\pi_T. \alpha_t$ , after  $\alpha_{t_{i+1}}$ .
- Consider  $tr_2 \in \text{visible}(\tau_i, t_{i+1}, x)$ . Since  $t_x \in \text{readable}(\tau_i, t_{i+1}, x)$ , we have  $tr_2 [co_{i+1}^x] t_x$ . Now, in  $\alpha'_i. \pi_T$ , assume  $tr_3 [rf_0^{y'}] t$ , such that we have a path from  $tr_3$  to  $t_x$ , as  $tr_3 [po_i \cup rf_i \cup co_i]^* tr_2$ .

Hence it follows that  $tr_3 [po_i \cup rf_i \cup co_i]^* tr_2 [co_{i+1}^x] t_x [po_i \cup rf_i \cup co_i]^* tr_1$ . Hence we have  $tr_3 [po_{i+1} \cup rf_{i+1} \cup co_{i+1}]^+ tr_1$ , i.e  $tr_3 [po_n \cup rf_n \cup co_n]^+ tr_1$ . This leads to the contradiction since  $tr_1 \in \text{visible}(\tau, t, y)$  and  $tr_3 [rf_0^{y'}] t$ .

Hence,  $t_x \in \text{readable}(\tau_i, t_{i+1}, x)$  and we can extend the run from the inductive hypothesis obtaining  $\tau'_j \vdash_G \alpha_{t_{j+1}}$ ,  $\tau'_{j+1} = \alpha_{t_{j+1}}(\tau'_j)$ , for  $0 \leq j \leq i-1$ , and  $\tau'_i \vdash_G \alpha_{t_{i+1}}$ .

Now we prove that  $co'_{i+1} = co_{i+1} \cup co'$ . Assume we have  $(tr1, tr2) \in co_{i+1}$ . We show that  $(tr1, tr2) \in co'_{i+1}$ . We have the following cases:

- (i)  $(tr1, tr2) \in co_i$ . From the inductive hypothesis it follows that  $(tr1, tr2) \in co'_i$  and hence in  $co'_{i+1}$ .
- (ii)  $(tr1, tr2) \notin co_i$  and some read event  $ev = r(p, t_{i+1}, x, v)$  from  $\alpha_{t_{i+1}}$  reads from  $tr2$ . That is,  $tr1, tr2 \in \text{readable}(\tau_i, t_{i+1}, x)$  and  $tr1 \in \text{visible}(\tau_i, t_{i+1}, x)$ . Assume  $(tr1, tr2) \notin co'_{i+1}$ . Since  $(tr1, tr2) \notin co'_{i+1}$ , it follows that there exists  $tr3 \in \text{visible}(\tau'_i, t_{i+1}, x)$  such that  $tr2 [po'_i \cup rf'_i \cup co'_i] tr3$ . This means  $tr2 \in \text{readable}(\tau_i, t_{i+1}, x)$ , but  $tr2 \notin \text{readable}(\tau'_i, t_{i+1}, x)$ . However, as proved earlier, this leads to a contradiction.

Thus, we have shown that  $\tau \vdash_G \alpha'_i \alpha_{t_1} \dots \alpha_{t_i}$  is such that  $\alpha'_i \alpha_{t_1} \dots \alpha_{t_i}(\tau) = \tau'_i$  for all  $0 \leq i \leq n$ . When  $i = n$  we obtain  $\alpha'_i \pi_T(\tau) = \tau'_n$ , or  $\tau \vdash_G \alpha'_i \pi_T$ .  $\square$

*Definition G.14 (Linearization of a Trace).* A observation sequence  $\pi_T$  is a *linearization* of a trace  $\tau = \langle \mathcal{T}, po, rf, co \rangle$  if (i)  $\pi_T$  has the same transactions as  $\tau$  and (ii)  $\pi_T$  follows the  $(po \cup rf)$  relation.

We say that our DPOR algorithm *generates an observation sequence*  $\pi_T$  from state  $\langle \sigma, \tau \rangle$  where  $\sigma$  is a configuration and  $\tau$  is a trace if it invokes *ExploreTraces* with parameters  $\sigma, \tau, \pi'$ , where  $\pi'$  is a *linearization* of  $\tau$ , and generates a sequence of recursive calls to *ExploreTraces* resulting in  $\pi_T$ .

LEMMA G.15. *If  $\langle \sigma, \tau \rangle \vdash_{G_T} \pi_T$  then, the DPOR algorithm generates  $\pi'_T$  from state  $\langle \sigma, \tau \rangle$  for some  $\pi'_T \approx \pi_T$ .*

PROOF. We use induction on  $|\pi_T|$ . If  $\sigma$  is *terminal*, then the proof is trivial. Assume that we have  $\langle \sigma, \tau \rangle \vdash_{G_T} \pi_T$ . Assume that  $\langle \sigma, \tau \rangle \vdash_G \alpha_t$ . It follows that  $\langle \sigma, \tau \rangle \vdash_G \alpha_t$ . Using Lemma G.9 we get  $\pi_T = \pi_{T^1} \cdot \alpha_t \cdot \pi_{T^2}$ , where  $\pi_{T^1}$  is  $t$ -free. We consider the following two cases:

- In the first case, we assume that all read events in  $t$  read from transactions in  $\tau$ . So in this case,  $\pi_{T^1}$  can be empty. Assume there are  $n$  read events in  $t$  and each read event  $ev_i = r(p, t, x_i, v)$  reads from transactions  $t_i \in \tau$  for all  $i : 1 \leq i \leq n$ . In this case the DPOR algorithm will let each read event  $ev_i$  read from all possible transactions  $t' \in \text{readable}(\tau, t, x_i)$ , including  $t_i$ .
- In the second case, assume that there exists at least one read event  $ev' = r(p, t, x, v) \in \alpha_t$  which reads from a transaction  $t' \in \pi_{T^1}$  (hence,  $\pi_{T^1}$  is non empty).

From Lemma G.13, we know that  $\langle \sigma, \tau \rangle \vdash_G \alpha'_t \cdot \pi_{T^1}$ . From Lemma G.12, it follows that  $\langle \sigma, \tau \rangle \vdash_{G_T} \alpha'_t \cdot \pi_{T^1} \cdot \pi_{T^4}$ , for some  $\pi_{T^4}$ . Hence there exists  $\langle \sigma', \tau' \rangle$  such that  $\langle \sigma', \tau' \rangle = \alpha'_t(\langle \sigma, \tau \rangle)$  and  $\langle \sigma', \tau' \rangle \vdash_{G_T} \pi_{T^1} \cdot \pi_{T^4}$ .

Since  $|\pi_{T^1} \cdot \pi_{T^4}| < |\pi_T|$ , we can use the inductive hypothesis. It follows that the DPOR algorithm generates from state  $\langle \sigma', \tau' \rangle$ , the observation sequence  $\pi_{T^5}$  such that  $\pi_{T^5} \approx \pi_{T^1} \cdot \pi_{T^4}$ .

Let  $\pi_{T^3} \cdot \alpha_t = \text{Pre}(\pi_{T^1}, \alpha_t)$ . Then  $\pi_{T^5} \approx \pi_{T^1} \cdot \pi_{T^4}$  implies that  $\pi_{T^3} \lesssim \pi_{T^5}$  (by applying Lemma G.11). Let  $\pi_{T^6} \approx \pi_T \circ (\pi_{T^3} \cdot \alpha_t)$ . By applying Lemma G.10, we get  $\pi_T \approx \pi_{T^3} \cdot \alpha_t \cdot \pi_{T^6}$ . Since  $\langle \sigma, \tau \rangle \vdash_{G_T} \pi_T$  and  $\pi_T \approx \pi_{T^3} \cdot \alpha_t \cdot \pi_{T^6}$ , by applying Lemma G.7, we get  $\langle \sigma, \tau \rangle \vdash_{G_T} \pi_{T^3} \cdot \alpha_t \cdot \pi_{T^6}$ . Let  $\langle \sigma', \tau' \rangle = (\pi_{T^3} \cdot \alpha_t)(\langle \sigma, \tau \rangle)$ . Since  $\langle \sigma, \tau \rangle \vdash_{G_T} \pi_{T^3} \cdot \alpha_t \cdot \pi_{T^6}$ , we have  $\langle \sigma', \tau' \rangle \vdash_{G_T} \pi_{T^6}$ . From inductive hypothesis it follows that  $\langle \sigma', \tau' \rangle$  generates  $\pi_{T^7}$  such that  $\pi_{T^7} \approx \pi_{T^6}$ .

In other words,  $\langle \sigma, \tau \rangle$  generates  $\pi_{T^3} \cdot \alpha_t \cdot \pi_{T^7}$  where  $\pi_T \approx \pi_{T^3} \cdot \alpha_t \cdot \pi_{T^7}$ .

□



## Weak Causal Consistency CC

### H CC SEMANTICS

The transition rules in the labeled transition system (LTS) for CC is given in Figure 15.

$$\begin{array}{c}
 \frac{\text{begin} \in \text{inst}(\text{ls}(p).\text{pc}) \quad \text{ls}(p).\text{ts} < t \quad s = \text{ls}(p)[\text{log} \mapsto \epsilon, \text{snapshot} \mapsto \text{buildSnapshot}(\text{store}), \text{pc} \mapsto \text{next}(\text{pc})]}{(\text{ls}, \text{msgs}) \xrightarrow{\text{begin}(p, t)} (\text{ls}[p \mapsto s], \text{msgs})} \\
 \frac{r := x \in \text{inst}(\text{ls}(p).\text{pc}) \quad \text{cceval}(\text{ls}(p), x) = (v, t') \quad \text{rval} = \text{ls}(p).\text{rval}[r \mapsto v] \quad s = \text{ls}(p)[\text{rval} \mapsto \text{rval}, \text{pc} \mapsto \text{next}(\text{pc})]}{(\text{ls}, \text{msgs}) \xrightarrow{r(p, t, x, v)} (\text{ls}[p \mapsto s], \text{msgs})} \\
 \\
 \frac{x := v \in \text{inst}(\text{ls}(p).\text{pc}) \quad \text{log} = (\text{ls}(p).\text{log}) \cdot (x, v) \quad s = \text{ls}(p)[\text{log} \mapsto \text{log}, \text{pc} \mapsto \text{next}(\text{pc})]}{(\text{ls}, \text{msgs}) \xrightarrow{\text{isu}(p, t, x, v)} (\text{ls}[p \mapsto s], \text{msgs})} \\
 \frac{\text{end} \in \text{inst}(\text{ls}(p).\text{pc}) \quad s = \text{ls}(p)[\text{snapshot} \mapsto \epsilon, \text{pc} \mapsto \text{next}(\text{pc})]}{(\text{ls}, \text{msgs}) \xrightarrow{\text{end}(p, t)} (\text{ls}[p \mapsto s], \text{msgs} \cup \{(t, \text{ls}(p).\text{log})\})} \\
 \\
 \frac{\langle t, \text{log} \rangle \in \text{msgs} \quad \text{store} = \text{ls}(p).\text{store}[x \mapsto \text{update}(\text{ls}(p), x, t, \text{last}(\text{log}, x)) : x \in \mathcal{V}] \quad s = \text{ls}(p)[\text{store} \mapsto \text{store}, \text{pc} \mapsto \text{next}(\text{pc})]}{(\text{ls}, \text{msgs}) \xrightarrow{\text{del}(p, t)} (\text{ls}[p \mapsto s], \text{msgs})}
 \end{array}$$

Fig. 15. The set of transition rules defining the weak causal semantics. The function `buildSnapshot(store)` returns a consistent snapshot of the store. Function `cceval(ls(p), x)` returns the pair  $(\text{last}(\text{log}, x))$  if  $\text{last}(\text{log}, x) \neq \perp$ , otherwise returns the pair  $(v, t')$  in  $\text{ls}(p).\text{snapshot}(x)$ .

The set of executions of  $\mathcal{P}$  under weak causal consistency, denoted  $\text{Exec}_{\text{CC}}(\mathcal{P})$  are those executions satisfying transaction isolation and causal delivery. Figure 16(a) gives a sample program and its execution under CC. In this program, transactions  $t_1$  and  $t_3$  are concurrent. Hence,  $t_5$  can read from  $t_1$  while  $t_4$  reads from  $t_3$ . We denote all executions starting from configuration  $\sigma$  by  $\text{ExecFrom}(\sigma)$ .

### I CC AXIOMATIC SEMANTICS

As done for CCv in the main paper, we present the notions of execution summaries and traces first.

#### I.1 CC Execution Summaries, Traces

The notion of an execution summary is same for CC as it was for CCv. Given a CC execution  $\rho$ , its *execution summary*  $\text{Sum}(\rho)$  is obtained by replacing every subsequence in  $\rho$  delimited by `begin(p, t)` and `end(p, t)` event labels with a single operation `isu(p, t)`. Thus, the execution summary is a sequence of transitions over the events  $\text{EvSum}(\rho) = \{\text{isu}(p, t), \text{del}(p, t) \mid p \in \text{P}, t \in \mathcal{T}\}$ , and induces a total ordering  $<$  on these events. Let  $(\text{EvSum}(\rho), <)$  denote the execution summary corresponding to execution  $\rho$ . Fig. 16(b) gives the execution summary for the CC execution given in Fig. 16(a).

The execution summary  $(\text{EvSum}(\rho), <)$  induces two functions: the *happens-before* (as in CCv), and *read from the concurrent writes* relations (new in CC) as follows.

- $S.\text{hb} : \mathcal{T}(\rho)^r \rightarrow \text{p}(\mathcal{T}(\rho)^w)$  defined by  $S.\text{hb}(t_1) = \{t' \in \mathcal{T}(\rho)^w \mid \text{del}(p, t') < \text{isu}(p, t_1) \text{ for any } p \in \text{P}\}$ .

- $S.\text{cw} : \mathcal{T}(\rho)^r \times \mathcal{V} \rightarrow \text{p}(\mathcal{T}(\rho)^w)$ , defined by  $S.\text{cw}(t_1, x) = \{t' \mid t' \in S.\text{hb}(t_1) \cap \mathcal{T}(\rho)^{w,x}, t_1 \in \mathcal{T}(\rho)^{r,x} \text{ and } \forall t'' \in S.\text{hb}(t_1) \cap \mathcal{T}(\rho)^{w,x}, (t'.\text{id} \geq t''.\text{id} \vee (t' \text{ and } t'' \text{ are concurrent}))\}$ . That is,  $S.\text{cw}(t_1, x)$  is the set of *concurrent* transactions from which  $t_1$  can read from.

p1	p2
t1[x=5	t3[y=2]
x=1	t4[r2=z//1
y=1]	r3=y]//2
t2[z=1	t5[r4=y]//1
r1=x]//1	

(a) CC Program

$$\text{isu}(p1, t1) \cdot \text{isu}(p1, t2) \cdot \text{isu}(p2, t3) \cdot \text{del}(p2, t1) \cdot \text{del}(p2, t2) \cdot \text{isu}(p2, t4) \cdot \text{isu}(p2, t5)$$

(b) CC Execution Summary

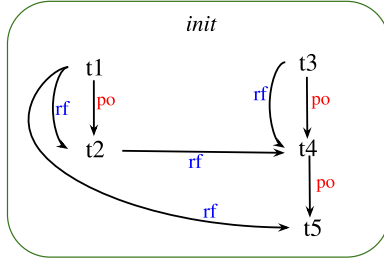

(c) CC Consistent Trace

Fig. 16. CC Execution and corresponding summary, trace

*Legal Summaries.* An execution summary  $S = \text{Sum}(\rho)$  is *legal* under CC iff:

1. Each transaction  $t$  in the domain of  $S.cw$  reads from a transaction  $t' \in S.cw(t, x)$  for all  $x$ . Each read is from the one of the eligible *concurrent* writes.
2. For every transaction  $t \in \mathcal{T}(\rho)^w$ , if  $\text{del}(p, t) < \text{isu}(p, t')$ , then  $\text{del}(p', t) < \text{del}(p', t')$  for all processes  $p, p'$ .
3. For every transaction  $t$  and processes  $p, p'$ ,  $\text{isu}(p, t) < \text{del}(p', t)$ .

Note that only the first condition of legality differs from that of CCv.

*Traces.* Unlike CCv, for CC, traces are built using only *po*, *rf* relations. Thus, a trace is given by  $\tau = (\mathcal{T}, \text{po}, \text{rf})$ . This is due to the fact that CC maintains writes from concurrent transactions to be read from. Recall that each time we begin a new transaction  $t$  in a process  $p$ , the local store of  $p$  is updated so that, for each variable  $x$ ,  $(v_1, t_1), (v_2, t_2) \in \text{ls}(p).\text{store}(x)$  iff  $t_1, t_2 \in \mathcal{T}^{w,x}$  are concurrent, and have happened before  $t$ . Thus, CC does not impose a *co* between such  $t_1, t_2$ , and dynamically chooses to read from any one such, at the onset of each fresh transaction  $t$ .

*Definition I.1.* (Total and Partial Traces) We say a trace is total if  $\tau = (\mathcal{T}, \text{po}, \text{rf})$  and all external reads are covered by the *rf* relation. It is partial otherwise.

*Definition I.2.* (Concurrent Transactions) Two transactions  $t$  and  $t'$  are *concurrent* if  $\neg(t[\text{po} \cup \text{rf}]^+ t)$  and  $\neg(t'[\text{po} \cup \text{rf}]^+ t)$ .

*Definition I.3* ( $\tau$ -consistent Execution Summaries). Given an execution summary  $\rho = \sigma_0 \xrightarrow{\ell_1} \sigma_1 \xrightarrow{\ell_2} \sigma_2 \xrightarrow{\ell_3} \sigma_3 \cdots \xrightarrow{\ell_{n-1}} \sigma_{n-1} \xrightarrow{\ell_n} \sigma_n$ , and a trace  $\tau = (\mathcal{T}, \text{po}, \text{rf})$ , we say that  $\rho$  is  $\tau$ -consistent denoted by  $\rho \models \tau$  if the following holds:

- ★ Each transaction  $t \in \mathcal{T}$  corresponds to exactly one label  $\text{isu}(-, t)$  in  $\rho$ .
- ★ For  $t, t' \in \mathcal{T}$ , if  $t[\text{po}] t'$ , then  $\exists \ell_i = \text{isu}(p, t), \ell_j = \text{isu}(p, t')$  with  $i < j$  in  $\rho$ .

- ★ For  $t \neq t' \in \mathcal{T}$ , if  $t \text{ [rf] } t'$ , then  $\exists \ell_i = \text{isu}(p', t), \ell_j = \text{del}(p, t), \ell_k = \text{isu}(p, t'), i < j < k$ , such that  $t \in \mathcal{T}^{w,x}, t' \in \mathcal{T}^{r,x}$  for some  $x \in \mathcal{V}$  and  $\forall \ell_m = \text{del}(p, t'). ((j < m < k \wedge t'' \in \mathcal{T}^{w,x}) \implies (t \text{ and } t'' \text{ are concurrent}))$ .
- ★ If  $\text{init}_x \text{ [rf] } t$ , then  $t$  has the read instruction  $r := x$ , which reads from  $\text{init}_x$  and the value read into  $r$  is 0.

*Definition I.4 (Partially Good Traces, CC consistent Traces).* For a trace  $\tau = (\mathcal{T}, \text{po}, \text{rf})$ , define  $\tau \models \text{CC}$  iff (i) for  $t_1, t_2, t_3 \in \mathcal{T}$ , if  $(t_1, t_2) \in \text{rf}^x, (t_3, t_2) \in [\text{po} \cup \text{rf}]^+$ , then  $t_3$  and  $t_1$  are concurrent or  $t_3[\text{po} \cup \text{rf}]^* t_1$  and (ii)  $(\text{po} \cup \text{rf})^+$  is irreflexive. A partial trace  $\tau$  for which we have  $\tau \models \text{CC}$  is a **partially good** trace. A partial trace  $\tau$  is **CC consistent** iff it can be extended to a total trace such that  $\tau \models \text{CC}$ .

For a configuration  $\sigma$ , let  $[[\sigma]]_{\text{CC}} = \{\tau \mid \exists \rho \in \text{ExecFrom}(\sigma), \rho \models \tau \text{ and } \tau \text{ is CC consistent}\}$  denote the set of all CC consistent traces from a configuration  $\sigma$ .

Fig. 16(c) gives a CC consistent trace for execution shows in Fig. 16(a).

**THEOREM I.5.** *A trace  $\tau$  is CC-consistent iff there is a legal and  $\tau$ -consistent execution summary  $S$  corresponding to  $\tau$ .*

**PROOF.** The proof is on similar lines as Theorem 4.1. First let us go from traces to legal execution summaries.

*1.1.1 CC-consistent Traces to Legal Execution Summaries.* Consider a partial trace  $\tau = (\mathcal{T}, \text{po}, -)$ . Assume that we can extend it to a complete, CC consistent trace  $\tau' = (\mathcal{T}, \text{po}, \text{rf})$ . Given  $\tau'$ , we show that we can construct a  $\tau'$ -consistent, legal execution summary.

Assume that we have processes  $p_1, p_2, \dots, p_n$  in the concurrent program  $\mathcal{P}$  over the set of transactions  $\mathcal{T}$ . Define for each  $i$ ,

- Let  $A_i$  be the set of all transactions  $t \in \mathcal{T}$  issued in process  $p_i$ ,
- Let  $A'_i = A_i \cup \mathcal{T}^w$ .  $A'_i$  contains all transactions issued in process  $p_i$ , as well as all transactions in  $\mathcal{T}$  having a write instruction,
- Define the relation  $<_i = ((hb \cap (A'_i \times A'_i)) \cup ((A_i \times (A'_i \setminus A_i)) \setminus hb^{-1}))$  where  $hb = (\text{po} \cup \text{rf})^+$ . Relation  $<_i$  is strict partial order.

Now define two sets  $T, T'$  as follows.

- Let  $T = \{\text{isu}(p_i, t) \mid 1 \leq i \leq n, t \in A_i\} \cup \{\text{del}(p_i, t) \mid 1 \leq i \leq n, t \in A'_i \setminus A_i\}$ . Thus,  $T$  consists of all transactions  $t$  issued in process  $p_i$ , or those transactions  $t$  delivered to process  $p_i$  (but not issued in  $p_i$ ).
- Let  $T' = \{\text{isu}(p_i, t) \mid 1 \leq i \leq n, t \in A_i \cap \mathcal{T}^w\}$ .  $T'$  consists of all transactions issued in process  $p_i$  which also have a write instruction.

We define the following relations on  $T, T'$ :

1.  $B_1 = \{\langle x(p_i, t), y(p_i, t') \rangle \in T \times T \mid x, y \in \{\text{isu}, \text{del}\} \text{ and } t <_i t'\}$ . By definition of  $\text{po} \cup \text{rf}$  and  $<_i$ ,  $B_1$  is acyclic.
2.  $B_2 = \{\langle \text{isu}(p_i, t), \text{del}(p_j, t) \rangle \in T' \times T\}$ .  $B_2$  is irreflexive.

Indeed  $B_1 \cup B_2$  is irreflexive. We build an execution summary using  $(B_1 \cup B_2)$ , and the relation  $<$  induced by  $B_1, B_2$ . The events in the execution summary are obviously,  $Ev = \{\text{isu}(p, t), \text{del}(p, t') \mid t, t' \in \mathcal{T} \text{ and } p \in \mathcal{P}\}$ , and the ordering  $<$  is defined as  $(a, b) \in (B_1 \cup B_2)^+ \implies a < b$ .

*1.1.2  $<$  is a total order.* : To show that  $(Ev, <)$  is a legal execution summary, one of the things to show is that  $<$  is a total order on the events  $Ev$ . To this end, we show that  $(B_1 \cup B_2)^+$  is irreflexive.

**LEMMA I.6.** *If  $\langle x(p_i, t_1), \text{isu}(p_j, t_2) \rangle \in (B_1 \cup B_2)^+$  then  $t_1[\text{po} \cup \text{rf}]^+ t_2$ .*

LEMMA I.7.  $<$  can be extended to a total order.

The proofs Lemmas I.6 and I.7 follow on the same lines as Lemmas A.1 and Lemma A.2.

We now show that the execution summary  $S = (Ev, <)$  is legal and  $\tau'$ -consistent under CC. Let the execution summary be  $S = \sigma_0 \xrightarrow{\ell_1} \sigma_1 \xrightarrow{\ell_2} \sigma_2 \xrightarrow{\ell_3} \sigma_3 \cdots \xrightarrow{\ell_{n-1}} \sigma_{n-1} \xrightarrow{\ell_n} \sigma_n$ .

$S = (Ev, <)$  is  $\tau'$ -consistent. We show that  $S$  satisfies all the conditions to be  $\tau'$ -consistent below.

- ★ First, each transaction  $t \in \mathcal{T}$  is issued in some unique process  $p_i$ . This is ensured by the total order  $<$ .
- ★ For  $t, t' \in \mathcal{T}$ , if  $t[po]t'$  in  $\tau'$ , we have  $t <_i t'$  by definition. This gives us  $(isu(p, t), isu(p, t')) \in B_1$ , giving  $\ell_i = isu(p, t), \ell_j = isu(p, t')$  in  $S$  with  $i < j$ .
- ★ For  $t, t' \in \mathcal{T}$ , if  $t'[rf^x]t$ , then we have  $t' <_i t$  by definition of  $<_i$ . This gives us  $(del(p, t'), isu(p, t)) \in B_1$ , giving  $\ell_j = del(p, t'), \ell_k = isu(p, t)$  with  $j < k$  in  $S, t' \in \mathcal{T}^{w,x}, t \in \mathcal{T}^{r,x}$ . And from  $B_2$  we have  $isu(p', t') < del(p, t')$ , i.e. we have  $\ell_i = isu(p', t')$  and  $\ell_j = del(p, t')$  with  $i < j$ .

$S = (Ev, <)$  is a legal execution summary. To show this, we must show the three conditions of legality hold good. Recall the functions  $S.hb : \mathcal{T}^r \rightarrow \mathfrak{p}(\mathcal{T}^w)$  and  $S.cw : \mathcal{T}^r \times \mathcal{V} \rightarrow \mathfrak{p}(\mathcal{T}^w)$ .

- (1) The first condition is to show that, each transaction  $t$  in process  $p_i$  reads from one of the concurrent writes, i.e. from a transaction  $t' \in S.cw(t, x)$  when  $t'[rf^x]t$ . Let  $(del(p_i, t'), isu(p_i, t)) \in B_1$  with  $t' \in \mathcal{T}^{w,x}, t \in \mathcal{T}^{r,x}, t' \in S.hb(t)$ , and  $t'[rf^x]t$ . We show that  $t' \in S.cw(t, x)$ .

Assume otherwise, that is, there exists a transaction  $t'' \in \mathcal{T}^{w,x}$  such that  $(del(p_i, t''), isu(p_i, t)) \in B_1, t'' \in S.cw(t, x)$  and  $t'.id < t''.id$ .

Since  $(del(p_i, t''), isu(p_i, t)) \in B_1$ , by Lemma I.6, we have  $t''[po \cup rf]^+t$ . Using  $t'[rf^x]t, t''[po \cup rf]^+t$  and the fact that  $\tau' \models CC$ , we have following cases:

- $t''[po \cup rf]^+t'$ . This implies that  $t''.id \geq t'.id$  since we have  $del(p, t'') < isu(p, t')$  from  $B_1$ . This however contradicts  $t'.id < t''.id$ . Thus,  $t' \in S.cw(t, x)$ .
- $t'$  and  $t''$  are concurrent. Since  $t'$  and  $t''$  are concurrent, we have  $\neg(t'[po \cup rf]^+t'')$  and  $\neg(t''[po \cup rf]^+t')$ . This implies that  $t''.id \not\leq t'.id$ . This however contradicts  $t'.id < t''.id$ . Thus,  $t' \in S.cw(t, x)$ .

- (2) The second condition to prove is this : For transactions  $t, t' \in \mathcal{T}^w$ , if  $del(p, t) < isu(p, t')$ , then  $del(p', t) < del(p', t')$  for any  $p' \neq p$ . If we have  $del(p, t) < isu(p, t')$ , then  $(del(p, t), isu(p, t')) \in B_1$ . By definition of  $B_1$ , then we have  $t <_p t'$ . By Lemma I.6, we have  $(t, t') \in [po \cup rf]^+$ . By definition of  $<_{p'} \supseteq hb \cap A'_{p'} \times A'_{p'}$ , we obtain  $t <_{p'} t'$  since  $t, t' \in \mathcal{T}^w$ . By  $B_1, t <_{p'} t'$  gives  $del(p', t) < del(p', t')$ .

- (3) The third condition is to show this : for each transaction  $t$  and processes  $p, p', isu(p, t) < del(p', t)$ . This is given to us by  $B_2$  already.

Thus, we have shown that we can construct a  $\tau'$ -consistent, legal execution summary from the CC consistent trace  $\tau'$ .

## I.2 Legal Execution Summaries to CC-consistent Traces

For the converse direction, assume that we begin with a legal execution summary  $Sum(\rho)$  corresponding to an execution  $\rho$ , under CC. First, we define the trace corresponding to  $\rho$ .

- For transactions  $t, t'$ , define  $t[po]t'$  when we have  $ev_1 = isu(p, t)$  and  $ev_2 = isu(p, t')$  such that  $ev_1 < ev_2$  in  $\tau$ . This corresponds to the order of transactions issued in process  $p$ .  $po$  does not relate the initializer transactions.
- $t[rf]t'$  relates transactions with store and issue events. If there exists  $ev_1 = del(p, t)$  and  $ev_2 = isu(p, t')$  such that  $ev_1 < ev_2$  in  $\tau$  such that  $t'$  performs an external read of some variable  $x$  from  $t$  and  $t \in S.cw(t', x)$ . The variable  $x$  can be made explicit by defining  $t[rf^x]t'$ .

We now show that the trace  $\tau$  as defined above is CC consistent. For this, we have to show the following.

- (1) Assume  $t_1[rf^x]t_2$  and  $t_3[po \cup rf]^+t_2$ . We show that  $t_3[po \cup rf]^+t_1$  or  $t_1$  and  $t_3$  are *concurrent*. Assume otherwise, that is,  $t_1[po \cup rf]^+t_3$ . Since  $t_3[po \cup rf]^+t_2$ , we have  $\text{del}(p_i, t_3) < \text{isu}(p_i, t_2)$ , i.e.  $t_3 \in S.hb(t_2)$ . Since  $t_1[po \cup rf]^+t_3$ , we have  $\text{isu}(p_j, t_1) < \text{isu}(p_k, t_3)$ , and hence  $t_1.id < t_3.id$ . Together with  $t_1, t_3 \in S.hb(t_2)$  and  $t_1.id < t_3.id$ , we have  $t_1 \notin S.cw(t_2, x)$ . Since  $t_1[rf^x]t_2$ , we have  $t_1 \in S.hb(t_2)$  and  $t_1 \in S.cw(t_2, x)$ . This is a contradiction.
- (2) Now we have to show that  $(po \cup rf)^+$  is acyclic. It is clear that  $po$  cannot generate cycles, since it picks transactions in increasing order of their identifiers. Assume we have a cycle. This corresponds to a sequence  $\text{isu}(p, t) < \dots < \text{del}(q, t) < \text{isu}(q, t_1) < \dots < \text{del}(r, t_1) < \text{isu}(p, t)$ . However this gives us  $\text{del}(q, t) < \text{isu}(q, t_1)$  as well as  $\text{del}(r, t_1) < \text{isu}(p, t) < \text{del}(r, t)$ . The last inequality comes from the third condition of a legal execution. However, this gives us  $\text{del}(q, t) < \text{isu}(q, t_1)$  and  $\text{del}(r, t_1) < \text{del}(r, t)$  contradicting the second condition of legal execution summaries.  
Hence,  $(po \cup rf)^+$  is acyclic.

□

## J CC FULFILLED SEMANTICS

As in the case of CCv, we give a notion of fulfilled semantics for CC, which ensures that we explore only CC consistent traces.

Trace  $\tau = (\mathcal{T}, po, rf)$  is fulfilled if for all transactions and for all variables  $x \in \mathcal{V}$  if  $t, t' \in \mathcal{T}^{w,x}$ ,  $t[po \cup rf]^+t''$  and  $t'[rf^x]t''$  then  $t$  and  $t'$  are *concurrent* or  $t[po \cup rf]^*t'$ .

**THEOREM J.1.** *A partial trace  $\tau = (\mathcal{T}, po, rf)$  is CC consistent if, it is fulfilled and partially good.*

**PROOF.** Consider a partial trace  $\tau$  which is fulfilled and partially good. We have to show that  $\tau$  can be extended to a total trace  $\tau'$  s.t.  $\tau' \models \text{CC}$ . To show this, we show that each extension  $\tau'$  of a fulfilled trace  $\tau$  is fulfilled, and is CC consistent. This is shown in Lemma J.2. □

### J.1 Fulfilled Semantics : Extending Partially Good, Fulfilled Traces

Our DPOR algorithm for CC proceeds by extending partially good fulfilled traces, to obtain CC consistent complete traces. For this, we define a *fulfilled semantics* which is a transition relations on pairs  $(\sigma, \tau)$  where  $\sigma$  is a configuration of the concurrent program  $\mathcal{P}$  and  $\tau$  is a (partial) trace. The transition relation  $\rightarrow_{\text{ful}}$  is defined as  $(\sigma, \tau) \xrightarrow{\alpha}_{\text{ful}} (\sigma', \tau')$  where the label  $\alpha$  is one of  $(\text{begin}, t)$ ,  $(\text{end}, t)$ ,  $(\text{read}, t, t')$ ,  $(\text{write}, t)$ .

- From a state  $(\sigma, \tau)$ , assume that we observe the  $\text{begin}(p, t)$  event. Then, the label  $\alpha$  is  $(\text{begin}, t)$ , giving the transition  $(\sigma, \tau) \xrightarrow{(\text{begin}, t)}_{\text{ful}} (\sigma', \tau')$ , where  $\tau = \langle \mathcal{T}, po, rf \rangle$ ,  $\tau' = \langle \mathcal{T}', po', rf \rangle$ ,  $\mathcal{T}' = \mathcal{T} \cup \{t\}$  and  $po' = po \cup t'[po]t$  where  $t', t$  are transactions in the same process  $p$ ,  $t'$  is the last transaction executed in  $p$ , and  $t$  is the next transaction in the  $po$  order of  $p$ . Fig.17(a) illustrates the effect of observing a  $\text{begin}(p, t7)$  event, where  $t7$  is the new transaction added to the trace. In Fig.17(a), assuming  $t1$  is the last transaction execution from process  $p$ , we add  $po$  edge from  $t1$  to  $t7$ .

- On a write event  $w(p, t, x, v)$  or an  $\text{end}(p, t)$  event, the state does not change, so we do not have any explicit transitions.

- From a state  $(\sigma, \tau)$ , assume that we observe the  $ev = r(p, t, x, v)$  event in transaction  $t$ . In this case, the label  $\alpha$  is  $(\text{read}, t, t')$ , where  $t'$  is the transaction from which  $t$  reads from, so that the

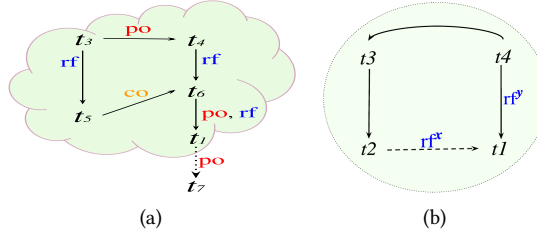

Fig. 17. Transition for (a) *begin* event and (b) *read* event.

trace  $\tau'$  in the target state  $(\sigma', \tau')$ , remains *fulfilled* and CC consistent. The transactions  $t'$  which qualify to be read from are prescribed using the *readable* sets  $\text{readable}(\tau, t, x)$ .

**Readable sets to respect CC consistency.** A readable set  $\text{readable}(\tau, t, x)$  contains all those transactions  $t'$  from which a read event on  $x$  of transaction  $t$  can read from, so that, on adding the edge  $(t', t)$  to  $rf'$ , the resultant trace  $\tau'$  is partially good and fulfilled. To let  $t' \in \text{readable}(\tau, t, x)$ , we check  $\neg\text{cond1} \wedge \neg\text{cond2}$  as given below. These conditions are sufficient to ensure that  $\tau'$  is fulfilled and partially good (Lemma J.2).

[(1)] To allow  $t'[rf^x]t$ , we check the following condition  $\neg\text{cond1}$  where

$\text{cond1} = \exists t_3 \in \mathcal{T}^{w,x}$  such that  $t'[po \cup rf]^+ t_3 [po \cup rf]^+ t$ . This check is made to ensure that we do not read from the transaction whose writes on  $x$  is overwritten before starting transaction  $t$ .

[(2)] To allow  $t'[rf^x]t$ , we check that the condition  $\neg\text{cond2}$  is true. Intuitively,  $\text{cond2}$  checks that allowing  $t'[rf^x]t$  will not violate CC semantics, by considering existing  $rf^y$  relations of  $t$  with respect to  $y \neq x$  (say  $t_4 [rf^y] t$ ) and analysing the  $[po \cup rf]^+$  paths from  $t_4$  to  $t'$ .

[★] Assume  $t_4 [po \cup rf]^* t'$  such that there is a  $t_3 \in \mathcal{T}^{w,y}$  in this path. Here,  $t_3$  can coincide with  $t'$ .

$\text{cond2} = [\exists t_3, t_4$  such that  $t_4 [rf^y] t, t_4 [po \cup rf]^+ t_3 [po \cup rf]^* t'$ ] with  $t_3 \in \mathcal{T}^{w,y}$ . Assuming  $\text{cond2}$  with  $t'[rf^x]t$ , we show CC violation.

- Case 1:  $t_3 = t'$ . Then we have  $t_4 [rf^y] t$  and  $t'[po \cup rf]^+ t$  (allowing  $t'[rf^x]t$ ). CC consistency requires  $t'[po \cup rf]^+ t_4$  or  $t', t_4$  are concurrent, violating  $t_4 [po \cup rf]^+ t'$ .

- Case 2 :  $t_3 \neq t'$ . Then we get  $t_3 [po \cup rf]^+ t$ . This along with  $t_4 [rf^y] t$  gives  $t_3 [po \cup rf]^+ t_4$  or  $t_3, t_4$  concurrent. If we have  $t_3 [po \cup rf]^+ t_4$  we get the  $[po \cup rf]^+$  cycle  $t_3 [po \cup rf]^+ t_4 [po \cup rf]^+ t_3$ , violating CC consistency. If we assume  $t_3, t_4$  concurrent, then it violates the assumption  $t_4 [po \cup rf]^+ t_3$  in  $\text{cond2}$ . See Figure 17(b).

Therefore, under the fulfilled semantics, if the transition  $(\sigma, \tau) \xrightarrow{\text{read}, t, t'}_{\text{ful}} (\sigma', \tau')$  occurs due to a read event  $ev$  in  $t$  which reads from  $t' \in \text{readable}(\tau, t, x)$ , then for trace  $\tau'$  we have  $\mathcal{T}' = \mathcal{T}$ ,  $rf' = rf \cup (t', t)$ . Lemma J.2 shows that if  $\tau$  is fulfilled and CC consistent, then the new trace  $\tau'$  obtained using  $\rightarrow_{\text{ful}}$  is also fulfilled and CC consistent.

LEMMA J.2. *If  $\tau$  is a fulfilled, partially good trace, and  $\tau \xrightarrow{\alpha}_{\text{ful}} \tau'$  then  $\tau'$  is fulfilled and CC consistent.*

PROOF. We prove this via the following lemmas.

$\tau \xrightarrow{\alpha}_{\text{ful}} \tau'$  and  $\tau$  fulfilled  $\Rightarrow \tau'$  fulfilled

LEMMA J.3. *For traces  $\tau_1$  and  $\tau_2$  if  $\tau_1 \xrightarrow{\text{begin}, t}_{\text{ful}} \tau_2$ , and  $\tau_1$  is fulfilled then  $\tau_2$  is fulfilled.*

PROOF. Let  $\tau_1 = \langle \mathcal{T}_1, po_1, rf_1 \rangle$  and  $\tau_2 = \langle \mathcal{T}_2, po_2, rf_2 \rangle$ . Assume  $\tau_1$  is fulfilled. By definition of  $\xrightarrow{\text{begin}, t}_{\text{ful}}$  it follows that  $\mathcal{T}_1 \subseteq \mathcal{T}_2, po_1 \subseteq po_2, rf_1 \subseteq rf_2$ . Assume that  $t_1 [po_2 \cup rf_2]^+ t_2$  and  $t'$



$[rf_2^y]t_2$ . We show that either  $t_1 [po \cup rf]^+ t'$  or  $t_1$  and  $t'$  are *concurrent*. The newly added transaction  $t \in \mathcal{T}_2$  has no successors in  $po_2 \cup rf_2$ , hence it follows that  $t_1 [po_1 \cup rf_1]^+ t_2$  and  $t' [rf_1^y]t_2$ . As  $\tau_1$  is fulfilled, we have either  $t_1 [po_1 \cup rf_1]^+ t'$  or  $t_1$  and  $t'$  are *concurrent* in  $\tau_1$ . If  $t_1 [po_1 \cup rf_1]^+ t'$  then we have  $t_1 [po_2 \cup rf_2]^+ t'$ , i.e.  $\tau_2$  is fulfilled. If  $t_1$  and  $t'$  are *concurrent* in  $\tau_1$  then  $t_1$  and  $t'$  will still remain *concurrent* in  $\tau_2$ . This makes  $\tau_2$  is fulfilled. Thus,  $\tau_2$  is fulfilled whenever  $\tau_1$  is.  $\square$

LEMMA J.4. For traces  $\tau_1$  and  $\tau_2$  if  $\tau_1 \xrightarrow{(read,t,t')}_{\text{ful}} \tau_2$ , and  $\tau_1$  is fulfilled then  $\tau_2$  is fulfilled.

PROOF. Let  $\tau_1 = \langle \mathcal{T}_1, po_1, rf_1 \rangle$ ,  $\tau_2 = \langle \mathcal{T}_2, po_2, rf_2 \rangle$ . Let  $ev = r(p, t, x, v)$  be the read event in  $t$ , and let  $t' \in \text{readable}(\tau, t, x)$  be the chosen transaction that  $t$  reads from, while  $\tau_1 \xrightarrow{(read,t,t')}_{\text{ful}} \tau_2$ . Then  $\mathcal{T}_2 = \mathcal{T}_1$ ,  $po_2 = po_1$ , and  $rf_2 = rf_1 \cup (t', t)$ . Assume for any two transactions  $t_1, t_2$  and any variable  $y$ ,  $t_1 [po_2 \cup rf_2]^+ t_3$  and  $t_2 [rf_2^y] t_3$ . We show that either  $t_1 [po_2 \cup rf_2]^+ t_2$  or  $t_1$  and  $t_2$  are *concurrent*. Since  $t$  has no successors in  $po_2 \cup rf_2$ , we only need to consider the following cases.

- $y = x$ ,  $t_3 = t$ ,  $t_2 = t'$ . From the definition of  $\xrightarrow{(read,t,t')}_{\text{ful}}$ , we have  $t_2 \in \text{readable}(\tau_1, t_3, x)$ . So we have either  $t_1 [po_1 \cup rf_1]^+ t_2$  or  $t_1$  and  $t_2$  are *concurrent*. Since  $t$  has no successor in  $(po_2 \cup rf_2)$ , it follows that in  $\tau_2$  we will have either  $t_1 [po_2 \cup rf_2]^+ t_2$  or  $t_1$  and  $t_2$  as *concurrent* transactions.
- $y \neq x$ . Since  $rf_2 = rf_1 \cup t'[rf]t$ ,  $t_1 [po_2 \cup rf_2]^+ t_3$  and  $t_2 [rf_2^y] t_3$ , it follows that  $t_1 [po_1 \cup rf_1]^+ t_3$  and  $t_2 [rf_1^y] t_3$ . Since  $\tau_1$  is fulfilled, we have either  $t_1 [po_1 \cup rf_1]^+ t_2$  or  $t_1$  and  $t_2$  are *concurrent*. Since only new edge added in  $\tau_2$  is  $t'[rf^x]t$ , we will have either  $t_1 [po_2 \cup rf_2]^+ t_2$  or  $t_1$  and  $t_2$  as *concurrent* transactions in  $\tau_2$ . Thus,  $\tau_2$  is fulfilled.  $\square$

$\tau \xrightarrow{\alpha}_{\text{ful}} \tau'$  and  $\tau \models \text{CC} \Rightarrow \tau' \models \text{CC}$

LEMMA J.5. If  $\tau_1 \models \text{CC}$  and  $\tau_1 \xrightarrow{(begin,t)}_{\text{ful}} \tau_2$  then  $\tau_2 \models \text{CC}$ .

PROOF. The proof follows trivially since we do not change the reads from relations, and the transaction  $t$  added has no successors in  $(po_2 \cup rf_2)$ . Thus, if  $\tau_1 \models \text{CC}$ , so does  $\tau_2$ .  $\square$

LEMMA J.6. If  $\tau_1 \models \text{CC}$  and  $\tau_1 \xrightarrow{(read,t,t')}_{\text{ful}} \tau_2$  then  $\tau_2 \models \text{CC}$ .

PROOF. Let  $\tau_1 = \langle \mathcal{T}_1, po_1, rf_1 \rangle$ ,  $\tau_2 = \langle \mathcal{T}_2, po_2, rf_2 \rangle$ , and  $ev = r(p, t, x, v)$  be a read event in transaction  $t \in \mathcal{T}_1$  such that  $ev$  reads value of  $x$  from the transaction  $t'$ . Suppose  $\tau_2 \not\models \text{CC}$ , and that  $po_2 \cup rf_2$  is cyclic. Since  $\tau_1 \models \text{CC}$ , and  $t$  has no outgoing edges, just by adding  $(t', t) \in rf_2$  we can not get cycle in  $(po \cup rf)$ . Now, suppose that are transactions  $t_1, t_2$  and  $t_3$  such that  $t_1 [po_2 \cup rf_2]^+ t_3$  and  $t_2 [rf_2^y] t_3$ . We need to show that in trace  $\tau_2$  either  $t_1 [po \cup rf]^+ t_2$  or  $t_1$  and  $t_2$  are concurrent transactions. We consider following cases:

- $t_3 = t$ ,  $t_2 = t'$ . From the definition of  $\xrightarrow{(read,t,t')}_{\text{ful}}$ , we have  $t_2 \in \text{readable}(\tau_1, t_3, x)$ . So we have either  $t_1 [po_1 \cup rf_1]^+ t_2$  or  $t_1$  and  $t_2$  are *concurrent*. Since  $t$  has no successor in  $(po_2 \cup rf_2)$ , it follows that in  $\tau_2$  we will have either  $t_1 [po_2 \cup rf_2]^+ t_2$  or  $t_1$  and  $t_2$  as *concurrent* transactions. Thus,  $\tau_2 \models \text{CC}$ .
- $t_3 \neq t$ ,  $t_2 \neq t'$ . Since  $rf_2 = rf_1 \cup t'[rf]t$  and  $t_1 [po_2 \cup rf_2]^+ t_3$  and  $t_2 [rf_2^y] t_3$ , it follows that  $t_1 [po_1 \cup rf_1]^+ t_3$  and  $t_2 [rf_1^y] t_3$ . Since  $\tau_1 \models \text{CC}$ , we have either  $t_1 [po_1 \cup rf_1]^+ t_2$  or  $t_1$  and  $t_2$  are *concurrent*. Since only new edge added in  $\tau_2$  is  $t'[rf^x]t$ , we will have either  $t_1 [po_2 \cup rf_2]^+ t_2$  or  $t_1$  and  $t_2$  as *concurrent* transactions in  $\tau_2$ . Thus,  $\tau_2 \models \text{CC}$  is.  $\square$

Thus, Lemma J.3, J.4, J.5 and J.6 prove Lemma J.2.  $\square$

LEMMA J.7. *Given trace  $\tau$ , a transaction  $t$  and a variable  $x$ , we can construct the sets  $\text{readable}(\tau, t, x)$  in polynomial time.*

Define  $[[\sigma]]^{\text{ful}}$  as the set of traces generated using  $\rightarrow_{\text{ful}}$  transitions, starting from a configuration  $\sigma$  with an empty trace  $\tau_\emptyset$ .  $[[\sigma]]^{\text{ful}} = \{\tau \mid (\sigma, \tau_\emptyset) \xrightarrow{*}_{\text{ful}} (\sigma', \tau)\}$ . We define  $[[\sigma]]_{\text{CC}}^{\text{ful}} = [[\sigma]]_{\text{CC}} \cap \{\tau \mid \tau \text{ is CC consistent}\}$ . Theorem J.8 shows that CC and the fulfilled semantics coincide.

THEOREM J.8. *For any configuration  $\sigma$ ,  $[[\sigma]]_{\text{CC}}^{\text{ful}} = [[\sigma]]_{\text{CC}}$ .*

PROOF. We have to show that  $[[\sigma]]_{\text{CC}} \subseteq [[\sigma]]_{\text{CC}}^{\text{ful}}$ . We have shown that under the fulfilled semantics, all the generated traces  $\tau$  are CC consistent. Note that by definition of  $\tau \models \text{CC}$ ,  $\tau$  is also fulfilled. The first condition in the definition of  $\tau \models \text{CC}$  gives the fulfilled-ness of  $\tau$ . Also, we have shown that under the fulfilled semantics, any trace remains CC consistent (Lemmas J.5, J.6). Thus, we know that any trace in  $[[\sigma]]_{\text{CC}}$  is fulfilled and CC consistent, giving the result.  $\square$

## K THE CC DPOR ALGORITHM

The DPOR algorithm for CC is similar to the DPOR algorithm for CCv. The procedures *ExploreTraces* and *RunSchedule* for CC are the same for CCv given in Algorithms 1 and 3, respectively.

The procedure *CreateSchedule* given in Algorithm 2 is modified in line 10 as follows: we will not have condition  $\neg(\text{co-cycle}(t_1, t_2))$ . Note that this is because we do not have *co* relations in CC traces.

**Soundness of CC DPOR.** If we initiate *ExploreTraces* from a configuration  $\sigma$  and the empty trace  $\tau_\emptyset$  with the empty observation sequence, then all explored traces  $\tau$  are such that  $\tau \in [[\sigma]]_{\text{CC}}^{\text{ful}} = [[\sigma]]_{\text{CC}}$ . This follows from the fact that the exploration uses the fulfilled semantics.

**Optimality of CC DPOR.** Proof for optimality of CC-DPOR is similar to optimality proof for CCv-DPOR.

### K.1 Completeness of CC DPOR

Proof for completeness of DPOR for CC follows the same schema as the completeness proof for CCv-DPOR. The only difference is in Lemmas G.6 and G.13. We prove Lemmas K.1 and K.2, which are the CC counterpart of Lemmas G.6 and G.13, respectively.

LEMMA K.1. *If  $\tau \vdash_G \alpha_{t_2}$  and  $\alpha_{t_1} \sim \alpha_{t_2}$  then  $\tau \vdash_G \alpha_{t_2} \cdot \alpha_{t_1}$  and  $(\alpha_{t_1} \cdot \alpha_{t_2})(\tau) \equiv (\alpha_{t_2} \cdot \alpha_{t_1})(\tau)$ .*

PROOF. Let  $\tau = \langle \mathcal{T}, \text{po}, \text{rf} \rangle$  be a trace and let  $t_1$  be a transaction issued in process  $p_1$ , and  $t_2$  be a transaction issued in process  $p_2$ , with  $p_1 \neq p_2$ . Assume  $\tau \vdash_G \alpha_{t_1} \cdot \alpha_{t_2}$ , with  $\alpha_{t_1} \sim \alpha_{t_2}$ .

We consider the following cases.

- $t_1, t_2 \notin \mathcal{T}^r$ . In this case  $\tau \vdash_G \alpha_{t_2} \cdot \alpha_{t_1}$  holds trivially.  
 $(\alpha_{t_1} \cdot \alpha_{t_2})(\tau) = (\alpha_{t_2} \cdot \alpha_{t_1})(\tau) = \langle \mathcal{T}', \text{po}', \text{rf} \rangle$ , where  $\mathcal{T}' = \mathcal{T} \cup \{t_1, t_2\}$  and  $\text{po}' = \text{po} \cup \{(t, t_1) \mid t \in p_1\} \cup \{(t', t_2) \mid t' \in p_2\}$ .
- $t_1 \in \mathcal{T}^w$ ,  $t_1 \notin \mathcal{T}^r$  and  $t_2 \in \mathcal{T}^r \cap \mathcal{T}^w$ . Let  $\tau_1 = \alpha_{t_1}(\tau)$ . We know that  $\tau_1 = \langle \mathcal{T}_1, \text{po}_1, \text{rf}_1 \rangle$ , where  $\mathcal{T}_1 = \mathcal{T} \cup \{t_1\}$ , and  $\text{po}_1 = \text{po} \cup \{(t, t_1) \mid t \in p_1\}$ , with  $\text{rf}_1 = \text{rf}$  since there are no read events in  $t_1$ .

Consider  $\tau_2 = \alpha_{t_2}(\tau_1) = \langle \mathcal{T}_2, \text{po}_2, \text{rf}_2, \text{co}_2 \rangle$ . Since  $t_2 \in \mathcal{T}^r$ , we know that  $t_2$  has read events. Let there be  $n$  read events  $ev_1 \dots ev_n$  in transaction  $t_2$ , reading from transactions  $t'_1, \dots, t'_n$  on variables  $x_1, \dots, x_n$ . Hence we get a sequence  $\tau_1 \xrightarrow{(\text{begin}, t_2)}_{\text{ful}} \dots \tau'_{i_1} \xrightarrow{(\text{read}, t_2, t'_1)}_{\text{ful}} \tau_{i_1} \rightarrow_{\text{ful}}$

$\dots \tau'_{i_n} \xrightarrow{\text{ful}}^{\text{(read}, t_2, t'_n)} \tau_{i_n} \dots \xrightarrow{\text{ful}}^{\text{(end}, t_2)} \tau_2$ . Hence  $\mathcal{T}_2 = \mathcal{T}_1 \cup \{t_2\}$ ,  $\mathbf{po}_2 = \mathbf{po}_1 \cup \{(t', t_2) \mid t' \in p_2\}$ ,  $\mathbf{rf}_2 = \mathbf{rf}_1 \cup (\mathbf{rf}_{i_1} \cup \mathbf{rf}_{i_2} \dots \cup \mathbf{rf}_{i_n})$ . Since  $\tau_1 \vdash_G \alpha_{t_2}$ , for all  $ev_i : 1 \leq i \leq n$ , we have  $t'_i \in \text{readable}(\tau_1, t_2, x_i)$ .

Since  $\alpha_{t_1} \sim \alpha_{t_2}$ , we know that for all  $ev_i : 1 \leq i \leq n$ , we have  $t'_i \in \text{readable}(\tau, t_2, x_i)$ . It follows that  $\tau \vdash_G \alpha_{t_2}$ . Define  $\tau_3 = \langle \mathcal{T}_3, \mathbf{po}_3, \mathbf{rf}_2 \rangle$ , where  $\mathcal{T}_3 = \mathcal{T} \cup \{t_2\}$  and  $\mathbf{po}_3 = \mathbf{po} \cup \{(t', t_2) \mid t' \in p_2\}$ . It follows that  $\alpha_{t_2}(\tau) = \tau_3$ ,  $\tau_3 \vdash_G \alpha_{t_1}$  and  $\tau_2 = \alpha_{t_1}(\tau_3) = \alpha_{t_2}(\alpha_{t_1}(\tau))$ .

- $t_2 \in \mathcal{T}^w$  and  $t_1 \in \mathcal{T}^r \cap \mathcal{T}^w$ . Similar to previous case.
- $t_1, t_2 \in \mathcal{T}^r \cap \mathcal{T}^w$ . Let  $\tau_1 = \alpha_{t_1}(\tau) = \langle \mathcal{T}_1, \mathbf{po}_1, \mathbf{rf}_1 \rangle$  and  $\tau_2 = \alpha_{t_2}(\tau_1)$ . Since  $t_1 \in \mathcal{T}^r$ , we know that  $t_1$  has read events. Let there be  $n$  read events  $ev_1 \dots ev_n$  in transaction  $t_1$ , reading from transactions  $t'_1, \dots, t'_n$  on variables  $x_1, \dots, x_n$ . Hence we get the sequence  $\tau \xrightarrow{\text{ful}}^{\text{(begin}, t_1)} \tau_{i_1} \dots \tau'_{i_1} \xrightarrow{\text{ful}}^{\text{(read}, t_1, t'_1)} \tau_{i_1} \rightarrow_{\text{ful}} \dots \tau'_{i_n} \xrightarrow{\text{ful}}^{\text{(read}, t_1, t'_n)} \tau_{i_n} \dots \xrightarrow{\text{ful}}^{\text{(end}, t_1)} \tau_1$ . Since  $t_2 \in \mathcal{T}^r$ , we know that  $t_2$  has read events. Let there be  $m$  read events  $ev'_1 \dots ev'_m$  in transaction  $t_2$ , reading from transactions  $t''_1, \dots, t''_m$  on variables  $y_1, \dots, y_m$ . Then we get the sequence  $\tau_1 \xrightarrow{\text{ful}}^{\text{(begin}, t_2)} \tau_{j_1} \dots \tau'_{j_1} \xrightarrow{\text{ful}}^{\text{(read}, t_2, t''_1)} \tau_{j_1} \rightarrow_{\text{ful}} \dots \tau'_{j_n} \xrightarrow{\text{ful}}^{\text{(read}, t_2, t''_n)} \tau_{j_n} \dots \xrightarrow{\text{ful}}^{\text{(end}, t_2)} \tau_2$ .

Proving  $\tau \vdash_G \alpha_{t_2} \cdot \alpha_{t_1}$

Since  $\tau_1 = \alpha_{t_1}(\tau)$ , for all read events  $ev_i$  such that  $ev_i.trans = t_1$ , we have  $t'_i \in \text{readable}(\tau, t_1, x_i)$ . Since  $\tau_2 = \alpha_{t_2}(\tau_1)$ , for all read events  $ev'_j$  such that  $ev'_j.trans = t_2$ , we have  $t''_j \in \text{readable}(\tau_1, t_2, y_j)$ . Since  $\alpha_{t_1} \sim \alpha_{t_2}$ , it follows that, we have  $t''_j \in \text{readable}(\tau, t_2, y_j)$  for all read events  $ev'_j$  such that  $ev'_j.trans = t_2$ . Hence  $\tau \vdash_G \alpha_{t_2}$ .

Consider  $\tau_3 = \alpha_{t_2}(\tau) = \langle \mathcal{T}_3, \mathbf{po}_3, \mathbf{rf}_3 \rangle$ . To show that  $\tau \vdash_G \alpha_{t_2} \alpha_{t_1}$ , we show that for all read events  $ev_i$  such that  $ev_i.trans = t_1$ ,  $t'_i \in \text{readable}(\tau_3, t_1, x_i)$ . We prove this using contradiction. Assume that  $\exists t'_i$  s.t.  $t'_i \notin \text{readable}(\tau_3, t_1, x_i)$ .

If  $t'_i \notin \text{readable}(\tau_3, t_1, x_i)$ , then there is a  $t'_k$  such that  $t'_k \in \text{readable}(\tau_3, t_1, x_i)$  and  $t'_i [\mathbf{po}_3 \cup \mathbf{rf}_3]^+ t'_k$ .

If  $t'_k \in \text{readable}(\tau_3, t_1, x_i)$ , since  $\alpha_{t_1} \sim \alpha_{t_2}$ , we also have  $t'_k \in \text{readable}(\tau, t_1, x_i)$ . Since new relations added in  $\tau_3$  are  $\mathbf{po}_3 = \mathbf{po} \cup \{(t', t_2) \mid t' \in p_2\}$  and  $\mathbf{rf}_3 = \mathbf{rf} \cup_{j:1 \leq j \leq m} t''_j [\mathbf{rf}^{y_j}] t_2$ , we can have  $t'_i [\mathbf{po}_3 \cup \mathbf{rf}_3]^+ t'_k$  only if there is a path from  $t'_i$  to  $t'_k$  in  $\tau$ ; that is,  $t'_i [\mathbf{po} \cup \mathbf{rf}]^+ t t'_k$ . This implies that  $t'_i \notin \text{readable}(\tau, t_1, x_i)$  which is a contradiction.

Thus, we have  $\neg(t'_i [\mathbf{po}_3 \cup \mathbf{rf}_3]^+ t'_k)$ . This, for all  $1 \leq i \leq n$ ,  $t'_i \in \text{readable}(\tau_3, t_1, x_i)$ . Thus, we now have  $\tau \vdash_G \alpha_{t_2} \alpha_{t_1}$ . It remains to show that  $(\alpha_{t_1} \cdot \alpha_{t_2})(\tau) \equiv (\alpha_{t_2} \cdot \alpha_{t_1})(\tau)$ .

Proving  $(\alpha_{t_1} \cdot \alpha_{t_2})(\tau) \equiv (\alpha_{t_2} \cdot \alpha_{t_1})(\tau)$

Define  $\tau_4 = \alpha_{t_1}(\tau_3) = \alpha_{t_1} \cdot \alpha_{t_2}(\tau) = \langle \mathcal{T}_4, \mathbf{po}_4, \mathbf{rf}_4 \rangle$ .

Recall that  $\tau_2 = \alpha_{t_2} \cdot \alpha_{t_1}(\tau) = \langle \mathcal{T}_2, \mathbf{po}_2, \mathbf{rf}_2 \rangle$ . Since,  $\alpha_{t_2} \sim \alpha_{t_1}$ , we have  $\mathbf{rf}_2 = \mathbf{rf}_4$ . It follows trivially that  $\mathcal{T}_4 = \mathcal{T}_2$  and  $\mathbf{po}_4 = \mathbf{po}_4$ . Since  $\mathcal{T}_2 = \mathcal{T}_4$ ,  $\mathbf{po}_2 = \mathbf{po}_4$ ,  $\mathbf{rf}_2 = \mathbf{rf}_4$ , it follows that  $(\alpha_{t_1} \cdot \alpha_{t_2})(\tau) \equiv (\alpha_{t_2} \cdot \alpha_{t_1})(\tau)$ . □

**LEMMA K.2.** Consider a fulfilled trace  $\tau$  such that  $\tau \models \text{CC}$ ,  $\tau \vdash_G \pi_T \cdot \alpha_t$ . Let each read event  $ev_i = r_i(p, t, x_i, v)$  in  $\alpha_t$  read from some transaction  $t_i$ , and let  $\pi_T$  be  $t$ -free. Then  $\tau \vdash_G \alpha'_t \cdot \pi_T$ , where  $\alpha'_t$  is the same as  $\alpha_t$ , with the exception that the sources of its read events can be different. That is, each read event  $ev_i = r_i(p, t, x_i, v) \in \alpha'_t$  can read from some transaction  $t'_i \neq t_i$ .

**PROOF.** Let  $\pi_T = \alpha_{t_1} \alpha_{t_2} \dots \alpha_{t_n}$  and  $\tau_0 \xrightarrow{\text{ful}}^{\alpha_{t_1}} \tau_1 \xrightarrow{\text{ful}}^{\alpha_{t_2}} \dots \xrightarrow{\text{ful}}^{\alpha_{t_n}} \tau_n \xrightarrow{\text{ful}}^{\alpha_t} \tau_{n+1}$ , where  $\tau_0 = \tau$ . Let  $\tau_i = \langle \mathcal{T}_i, \mathbf{po}_i, \mathbf{rf}_i \rangle$ . Let there be  $m$  read events in transaction  $t$ . Keeping in mind what we want to

prove, where we want to execute  $t$  first followed by  $\pi_T$ , and obtain an execution  $\alpha'_i \pi_T$ , we do the following.

For each read event  $ev_i = r_i(p, t, x_i, v)$  we define  $t'_i \in \mathcal{T}^{w, x_i}$  such that (i)  $t'_i \in \text{readable}(\tau_0, t, x_i)$ , and (ii) there is no  $t''_i \in \text{readable}(\tau_0, t, x_i)$  where  $t'_i [po_n \cup rf_n] t''_i$ . Note that this is possible since  $\pi_T$  is  $t$ -free, so all the observables  $\alpha_{t_i}$  occurring in  $\pi_T$  are such that  $t_i$  is issued in a process other than that of  $t$ . Thus, when  $\alpha_t$  is enabled, we can choose any of the writes done earlier, this fact is consistent with the CC semantics, since from Lemmas J.3-J.6 we know  $\tau_n \models \text{CC}$ . Since  $\tau_n \models \text{CC}$  such a  $t'_i \in \text{readable}(\tau_0, t, x_i)$  exists for each  $ev_i$ .

Next we define a sequence of traces which can give the execution  $\alpha'_i \pi_T$ . Define a sequence of traces  $\tau'_0, \tau'_1, \dots, \tau'_n$  where  $\tau'_j = \langle \mathcal{T}'_j, po'_j, rf'_j \rangle$  is such that

- (1)  $\tau \vdash_G \alpha'_i$  and  $\alpha'_i(\tau) = \tau'_0$ ,
- (2)  $\tau'_j \vdash_G \alpha_{t_{j+1}}$  and  $\tau'_{j+1} = \alpha_{t_{j+1}}(\tau'_j)$  for all  $j : 0 \leq j \leq n$ .
  - Define  $\mathcal{T}'_i = \mathcal{T}_i \cup \{t\}$  for all  $0 \leq i \leq n$ ,
  - Define  $po' = \{t' [po] t \mid t' \text{ is a transaction in } \tau, \text{ in the same process as } t\}$ , and  $po'_i = po_i \cup po'$  for all  $0 \leq i \leq n$ ,
  - $rf' = \bigcup_{i: 1 \leq i \leq n} t'_i [rf^{x_i}] t$  (reads from relation corresponding to each read event  $ev_i \in \alpha'_i$ ), and  $rf'_i = rf_i \cup rf'$  for all  $i : 1 \leq i \leq n$ ,

We show that  $\tau'_i \vdash_G \alpha_{t_{i+1}}$  and  $\tau'_{i+1} = \alpha_{t_{i+1}}(\tau'_i)$  holds good.

**Base case.** The base case  $\tau \vdash_G \alpha'_i$  and  $\alpha'_i(\tau) = \tau'_0$ , holds trivially, by construction.

**Inductive hypothesis.** Assume that  $\tau'_j \vdash_G \alpha_{t_{j+1}}$  and  $\tau'_{j+1} = \alpha_{t_{j+1}}(\tau'_j)$  for  $0 \leq j \leq i - 1$ .

We have to prove that  $\tau'_i \vdash_G \alpha_{t_{i+1}}$  and  $\tau'_{i+1} = \alpha_{t_{i+1}}(\tau'_i)$ .

- (1) If  $t_{i+1} \in \mathcal{T}^w$  and  $t_{i+1} \notin \mathcal{T}^r$ , then the proof holds trivially from the inductive hypothesis.
- (2) Consider now  $t_{i+1} \in \mathcal{T}^r$ . Consider a read event  $ev^{i+1} = r(p, t_{i+1}, x, v) \in \alpha_{t_{i+1}}$  which was reading from transaction  $t_x$  in  $\pi_T$ . That is, we had  $t_x \in \text{readable}(\tau_i, t_{i+1}, x)$ . If  $t_x \in \text{readable}(\tau'_i, t_{i+1}, x)$ , then we are done, since we can simply extend the run from the inductive hypothesis.

Assume otherwise. That is,  $t_x \notin \text{readable}(\tau'_i, t_{i+1}, x)$ . Since  $t_x \in \text{readable}(\tau_i, t_{i+1}, x)$ , we know that there are some blocking transactions in the new path which prevents  $t_x$  from being readable. Basically, we have the blocking transactions since  $t$  is moved before  $\pi_T$ . Consider  $tr_1 \in \text{readable}(\tau_i, t_{i+1}, x)$ . Since  $t_x \in \text{readable}(\tau_i, t_{i+1}, x)$  and  $t_x \notin \text{readable}(\tau'_i, t_{i+1}, x)$ , we have  $t_x [po'_i \cup rf'_i] tr_1$ . Since  $po'_i = po_i \cup po'$ ,  $rf'_i = rf_i \cup rf'$ , and  $t$  has no successor in  $\tau'_i$ , it follows that  $t_x [po_i \cup rf_i] tr_1$ . This contradicts the fact that  $t_x \in \text{readable}(\tau_i, t_{i+1}, x)$ .

Thus, we have shown that  $\tau \vdash_G \alpha'_i \alpha_{t_1} \dots \alpha_{t_i}$  is such that  $\alpha'_i \alpha_{t_1} \dots \alpha_{t_i}(\tau) = \tau'_i$  for all  $0 \leq i \leq n$ . When  $i = n$  we obtain  $\alpha'_i \pi_T(\tau) = \tau'_n$ , or  $\tau \vdash_G \alpha'_i \pi_T$ .  $\square$   $\square$

## L MORE DETAILS ON EXPERIMENTS

In this section, we provide more details to our experimental section. We reproduce Tables 1,2,3 first (now called Tables 4,5,6).

### L.1 Litmus Tests

As mentioned in the main file, we took the litmus tests from [Algave et al. 2014] and the outcomes mentioned in Table 1,4 are those of the Herd tool together with the set of RA-axioms provided in [Lahav et al. 2016].

Figure 19 is the one program among the 37 in the last row of Table 4 where the assertion violation reported by Herd shows up in CC when transactions are single instructions, while it still does not show up in CCv, since the violating execution is not CCv consistent. The assertion checked is on the

Table 4. TRANCHECKER on litmus tests.

Expected	Observed	Count
Allow	Allow	94
Forbid	Forbid	476
Forbid	Allow	194
Allow	Forbid	37 [ <b>36+1</b> ]

Table 5. Evaluating TRANCHECKER on Applications.

Applications	Transactions	Time
Vote [Difallah et al. 2013]	3	0.11s
Twitter [Holt et al. 2016]	4	0.09s
FusionTicket [Holt et al. 2016]	8	0.51s
Betting [Beillahi et al. 2021a]	5	0.20s
Auction [Nair et al. 2020]	8	0.11s
Auction-2 [Nair et al. 2020]	8	0.27s
Whatsapp	3	0.12s

Table 6. Evaluating behaviour of TRANCHECKER on classical benchmarks

Program	CCv	CC
Causality Violation [Bernardi and Gotsman 2016]	SAFE	SAFE
Causal Violation [Biswas and Enea 2019]	SAFE	SAFE
Co-Read Atomicity	SAFE	UNSAFE
Delivery Order [Beillahi et al. 2021b]	UNSAFE	UNSAFE
Load Buffer	SAFE	SAFE
Long Fork [Bernardi and Gotsman 2016]	UNSAFE	UNSAFE
Lost Update [Bernardi and Gotsman 2016]	UNSAFE	UNSAFE
Lost Update-2 [Bernardi and Gotsman 2016]	UNSAFE	UNSAFE
Modification Order	SAFE	UNSAFE
Message Passing [Beillahi et al. 2021a]	SAFE	SAFE
Conflict violation [Biswas and Enea 2019]	UNSAFE	UNSAFE
Serializability violation [Biswas and Enea 2019]	UNSAFE	UNSAFE
Read Atomicity [Biswas and Enea 2019]	SAFE	SAFE
Read Committed [Biswas and Enea 2019]	UNSAFE	UNSAFE
Repeated Read [Biswas and Enea 2019]	SAFE	SAFE
Repeated Read-2 [Biswas and Enea 2019]	SAFE	UNSAFE
Store Buffer	UNSAFE	UNSAFE
Write-po-Read	SAFE	SAFE
Write-po-Read-2	SAFE	SAFE
Write Skew [Bernardi and Gotsman 2016]	UNSAFE	UNSAFE

values of the variables commented out. Likewise, to illustrate the third row in Table 4, we show in Figure 18 how our transactional program looks like, after replacing a RMW in the original program from Herd-RA.

## L.2 Programs for Benchmarks

Fig. 20 gives the programs Load Buffer, Store Buffer, Modification Order, Write-po Read, Write-po Read-2, and Co-Read Atomicity. We have assertion conditions on the values given in comments in all of these programs. So, we say that a program is UNSAFE under CCv (CC) if the values shown in comments are observed under CCv (CC). Table 7 gives an evaluation of TRANCHECKER on second set of benchmarks under CCv, as an extension of Table 6. Executing version(iii) of these programs takes more time because we increase the number of transactions and processes. Table 8 gives an evaluation of TRANCHECKER on second set of benchmarks under CC, as an extension of Table 6.

p1	p2	p3
t1[x=1	t2[r2=y//1	t3[z=1
r1=f	r3=f	r5=f
f=1	f=2	f=3
y=1]	r4=z]//0	r6=x]//0

---

Fig. 18. The litmus program where observed outcome is *Forbid* under CCv and CC while the expected outcome is *Allow*. The Herd-RA program has the RMW `atomic_fetch_add(f,0)` in p1 which we replaced with the load and store statements `r1=f` and `f=1`. Likewise in the other two processes.

p1	p2	p3	p4
t1[x=1]	t3[y=3]	t5[r1=x]//4	t7[r3=y]//2
t2[y=2]	t4[x=4]	t6[r2=x]//1	t8[r4=y]//3

---

Fig. 19. The litmus program where CCv does not have the violating execution of Herd

### L.3 More details on Table 5

The third set of experiments includes seven applications. We instantiated each application with 3-6 users, where each user is modeled using 1 or 2 transactions.

- (1) Application Vote simulated voting, where each user can cast a vote only once.
- (2) Twitter application has two transactions, one to add a new user and the other to remove an existing user.
- (3) Application FusionTicket has two transactions: one for adding a new event to the venue and the other to know the total tickets sold.
- (4) Application Betting simulates time-based betting, where a user can only bet before the given time, and the winner could be anyone with a non-zero bet after the timeout.
- (5) Applications Auction and Auction-2 have two transactions each: to place bids and to close the auction and declare the winner. Application Auction is the buggy version where a non-high bid can win the auction. In Auction-2, the winner is the highest bid.
- (6) Application Whatsapp is synthetic. Application Whatsapp has a single transaction, which adds a user to the group if other members do not add him.



	p1			p2
	p1		p1	p2
	t1[r1=x//1 y=1]		t1[x=1 y=1]	t3[y=3 z=1]
	t2[r2=y//1 x=1]		t2[r1=z//0 r2=y]	t4[r3=x//0 r4=x]//0
(a) Load Buffer		(b) Store Buffer		
	p1		p1	p2
	t1[x=1 y=1]		t1[x=1 y=1]	t3[r2=x //1 y=2]
		t2[y=2 x=2 r1=x] //1	t2[r1=x]	t4[r3=x//1 r4=y]//1
		t3[r2=x //1 r3=y]//1		
(c) Write-po-Read		(d) Write-po-Read-2		
	p1	p2	p3	
	t1[x=1 y=1]	t2[y=2 x=2]	t3[r1=x//1 r2=y]//2	
(e) Co-Read Atomicity				
	p1	p2	p3	p4
	t1[x=2 y=1]	t2[y=2 z=1]	t3[z=2 x=1]	t4[r1=x//1 r2=y//1 r3=z]//1
(f) Modification Order				

Fig. 20. Our own programs used in Table 6

#### L.4 More details of Table 6 : Tables 7, 8

Here we provide the time taken by the three versions of all the benchmarks we tried in Table 6 for CCv.

Table 7. Detailed version of Table 6; TRANCHECKER on the classical benchmarks under CCv semantics.

Program	Outcome	Execution Time		
		Version(i)	Version(ii)	Version(iii)
Causality Violation	SAFE	0.07s	0.26s	24.63s
Causality Violation-2	SAFE	0.06s	0.09s	14.15s
Co-Read Atomicity	SAFE	0.03s	0.10s	12.64s
Delivery Order	UNSAFE	0.03s	0.07s	0.22s
Deliver Order-2	UNSAFE	0.03s	0.06s	0.19s
Load Buffer	SAFE	0.06s	0.38s	0.72s
Long Fork	UNSAFE	0.07s	0.19s	3.56s
Lost Update	UNSAFE	0.03s	0.06s	0.06s
Lost Update-2	UNSAFE	0.03s	0.06s	0.07s
Modification Order	SAFE	0.03s	0.40s	6.79s
Modification Order-2	SAFE	0.03s	5.40s	9.04s
Message Passing	SAFE	0.03s	0.12s	9.02s
Non-Serializablity	UNSAFE	0.03s	1.86s	0.72s
Non-Serializability-2	UNSAFE	0.03s	0.11s	16.45s
Read Atomic	SAFE	0.03s	1.24s	7.59s
Read Committed	UNSAFE	0.03s	0.10s	0.11s
Repeated Read	SAFE	0.03s	3.24s	33.56s
Repeated Read-2	SAFE	0.03ss	7.35s	3.15s
Store Buffer	UNSAFE	0.03s	0.12s	1.49s
Write-po-Read	SAFE	0.03s	0.07s	12.71s
Write-po-Read-2	SAFE	0.03s	0.07s	31.50s
Write Skew	UNSAFE	0.03s	0.05s	1.08s

Table 8. Detailed version of Table 6; TRANCHECKER on classical benchmarks under CC semantics.

Program	Outcome	Execution Time		
		Version(i)	Version(ii)	Version(iii)
Causality Violation	SAFE	0.09s	0.32s	25.24s
Causality Violation-2	SAFE	0.19s	0.17s	17.25s
Co-Read Atomicity	UNSAFE	0.07s	0.06s	0.75s
Delivery Order	UNSAFE	0.09s	0.04s	0.24s
Deliver Order-2	UNSAFE	0.04s	0.07s	0.21s
Load Buffer	SAFE	0.06s	0.61s	0.72s
Long Fork	UNSAFE	0.03s	0.22s	3.69s
Lost Update	UNSAFE	0.03s	0.07s	0.07s
Lost Update-2	UNSAFE	0.06s	0.06s	0.09s
Modification Order	UNSAFE	0.03s	0.06s	0.13s
Modification Order-2	UNSAFE	0.03s	0.06s	0.08s
Message Passing	SAFE	0.03s	0.10s	10.72s
Non-Serializability	UNSAFE	0.03s	2.91s	0.75s
Non-Serializability-2	UNSAFE	0.03s	0.07s	19.27s
Read Atomic	SAFE	0.03s	1.51s	8.92s
Read Committed	UNSAFE	0.03s	0.13s	0.13s
Repeated Read	SAFE	0.03s	5.30s	47.73s
Repeated Read-2	UNSAFE	0.03ss	0.14s	0.79s
Store Buffer	UNSAFE	0.03s	0.09s	1.66s
Write-po-Read	SAFE	0.03s	0.08s	16.00s
Write-po-Read-2	SAFE	0.03s	0.10s	40.39s
Write Skew	UNSAFE	0.03s	0.06s	2.56s