

Gemino: Practical and Robust Neural Compression for Video Conferencing

Vibhaalakshmi Sivaraman
Sadjad Fouladi 

Pantea Karimi
Mohammad Alizadeh

Vedantha Venkatapathy
Frédo Durand

Mehrdad Khani
Vivienne Sze

Massachusetts Institute of Technology,  Microsoft Research

Abstract

Video conferencing systems suffer from poor user experience when network conditions deteriorate because current video codecs simply cannot operate at extremely low bitrates. Recently, several neural alternatives have been proposed that reconstruct talking head videos at very low bitrates using sparse representations of each frame such as facial landmark information. However, these approaches produce poor reconstructions in scenarios with major movement or occlusions over the course of a call, and do not scale to higher resolutions. We design Gemino, a new neural compression system for video conferencing based on a novel *high-frequency-conditional super-resolution* pipeline. Gemino upsamples a very low-resolution version of each target frame while enhancing high-frequency details (e.g., skin texture, hair, etc.) based on information extracted from a single high-resolution reference image. We use a multi-scale architecture that runs different components of the model at different resolutions, allowing it to scale to resolutions comparable to 720p, and we personalize the model to learn specific details of each person, achieving much better fidelity at low bitrates. We implement Gemino atop *aiortc*, an open-source Python implementation of WebRTC, and show that it operates on 1024×1024 videos in real-time on a A100 GPU, and achieves 2.9× lower bitrate than traditional video codecs for the same perceptual quality.

1 Introduction

Video conferencing applications have become a crucial part of modern life. However, today’s systems continue to suffer from poor user experience: in particular, poor video quality and unwelcome disruptions are all too common. Many of these problems are rooted in the inability of today’s applications to operate in low-bandwidth scenarios. For instance, Zoom recommends a minimum bandwidth of 1.2 Mbps for one-on-one meetings [1]. When the network deteriorates, existing video conferencing solutions can cope to an extent by lowering quality, but below a certain bandwidth (e.g., 100s of Kbps for HD video), they must either suspend the transmission altogether or risk packet loss and frame corruption.

Recently, several neural approaches for face image synthesis have been proposed that deliver extreme compression by generating each video frame from a sparse representation (e.g., keypoints) [2–6]. While these techniques promise to enable video conferencing with one to two orders of magnitude

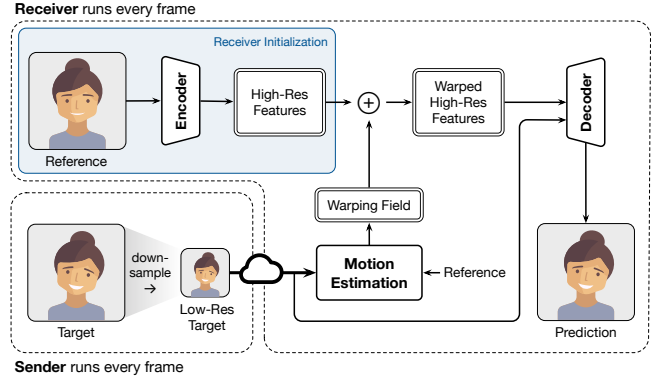

Figure 1: Gemino’s design. The sender sends a downsampled version of the target frame across the network to the receiver that has a reference image of the speaker in the current video conference setting. The encoder network encodes and warps features from the reference image based on the motion estimated between the reference and target frames. The decoder network at the receiver upsamples the downsampled frame with help from the warped encoded reference features.

reduction in bandwidth (as low as ~ 10 Kbps [3, 5]), lack of robustness and high computation complexity hamper their practicality. Specifically, synthesis approaches work by “warping” a reference image into different target poses and orientations. These methods produce good reconstructions when the difference between the reference and the target image is small, but they fail (possibly catastrophically) in the presence of large movements or occlusions. In such cases, they produce poor reconstructions, for both low-frequency content (e.g., missing the presence of a hand in a frame altogether) and high-frequency content (e.g., details of clothing and facial hair). As a result, while synthesis approaches show promising average-case behavior, their performance at the tail is riddled with inconsistencies in practice. Second, real-time reconstruction is only feasible at low resolution for most models [2, 5], even on high-end GPUs, while typical video conference applications are designed for HD, Full HD, and even 4K videos [7, 8]. Naïvely reusing these models on larger input frames can quickly become prohibitively expensive as the resolution is increased.

We present Gemino, a neural compression system for video conferencing, designed to overcome the above robustness and compute complexity challenges. Our design begins with the observation that current synthesis approaches, in an

effort to squeeze the most compression, rely too much on keypoints, a modality with limited semantic information about the target frame. This causes several inevitable failures (§2). For example, if a user’s hand is absent in the reference frame but appears in the target, there is no way to reconstruct the hand by warping the reference image. We would need to send a new reference frame that includes the hand, but sending a high-resolution frame (even occasionally) incurs significant cost. Instead, Gemini directly transmits low-resolution video, which includes significantly more information about the target frame, and upsamples it to the desired resolution at the receiver. Using low-resolution video is viable because modern codecs [9–12] compress them very efficiently. For example, sending 128×128 resolution video in our implementation consumes ~15 Kbps, only slightly more than would be needed to transmit keypoints [3, 5]. We posit that the robustness benefits of providing the receiver with more information for reconstruction far outweigh the marginal bandwidth cost.

It is challenging to upsample a video significantly while reconstructing high-frequency details accurately. For example, at 1024×1024 resolution, we can see high-frequency texture details of skin, hair, and clothing, that are not visible at 128×128 resolution. To improve high-frequency reconstruction fidelity, Gemini uses a reference frame that provides such texture information in a different pose than the target frame. Like synthesis approaches, it warps features extracted from this reference frame based on the motion between the reference and target frames, but it combines it with information extracted from the low-resolution target image to generate the final reconstruction (Fig. 1). We call this new approach *high-frequency-conditional super-resolution*

Gemino uses several further optimizations to improve reconstruction fidelity and reduce computation cost. First, we *personalize* the model by fine-tuning it on videos of a specific person so that it can learn the high-frequency detail associated with that person (e.g., hair, skin wrinkles, *etc.*). Personalizing the model makes it easier to transition texture information from the reference to the target frame. Second, we train the neural network using decompressed low-resolution frames obtained from a standard codec so that it learns to reconstruct accurate target frames despite codec-induced artifacts. We design Gemini to work with any starting resolution so that it can achieve different rate-distortion tradeoffs based on the available network bandwidth. The resolution at a particular bitrate is chosen by profiling standard codecs and picking the highest resolution that can achieve that bitrate.

Lastly, as the target resolution increases, it is essential to reduce the number of operations required per-pixel for synthesis. Otherwise, the compute overheads of running neural networks at higher resolutions become prohibitively high. To achieve this compute reduction, we design a *multi-scale* architecture wherein different parts of the model operate at different resolutions. For instance, the module that produces the warping field uses low-resolution versions of the reference

and target images, while the encoder and decoder networks¹ operate at full resolution but are equipped with additional downsampling blocks to reduce the operations per pixel. This design allows us to obtain good reconstruction quality while keeping the reconstruction real time. The multi-scale architecture will be particularly salient as we transition to higher resolution video conferencing applications in the future.

We implement and evaluate Gemini within *aiortc* [14], a Python implementation of WebRTC, and show the following:

1. Gemini achieves a perceptual quality (LPIPS) [15] of 0.17 at 196 Kbps, a 2.9× reduction from VP8’s default setting for Chromium and WebRTC.
2. In low-bitrate regimes where current video conferencing applications *cannot* operate, Gemini outperforms simple bicubic upsampling and SwinIR [16] super-resolution from compressed (VP8) downsampled frames. Gemini requires 50 Kbps to achieve an LPIPS of 0.23, a 3× and 3.9× reduction compared to bicubic and super-resolution respectively.
3. Our model transitions smoothly across resolutions, and between generated and synthetic video, achieving different rate-distortion tradeoffs based on the target bitrate.
4. Our model benefits considerably (~0.05 in LPIPS) from personalizing it to the specific texture of each person, and from including the VP8 codec at train-time (~0.05 in LPIPS). Our multi-scale architecture also enables inference on 1024×1024 frames in 17 ms on an NVIDIA A100 GPU, and 41 ms on an NVIDIA V100 GPU.

2 Related Work

Traditional Codecs. Most video applications rely on standard video compression modules (codecs) such as H.264/H.265 [17, 18], VP8/VP9 [19, 20], and AV1 [9]. These codecs separate video frames into keyframes (I-frames) that exploit spatial redundancies within a frame, and predicted frames (P-/B-frames) that exploit temporal—as well as spatial—redundancies across frames. Over the years, these standards have been improved through ideas like variable block sizes [18] and low-resolution encoding for lower bitrates [9]. These codecs are particularly efficient in their *slow* modes when they have generous time and compute budget to compress a video at high quality. However, these codecs still require a few hundred Kbps for real-time applications such as video conferencing, even at moderate resolutions like 720p. In low-bandwidth scenarios, these codecs cannot do much other than transmit at the worst quality, and suffer packet loss and frame corruption [21]. To circumvent this, some applications [22] switch to lower resolutions when the network degrades. However, as new video conferencing solutions such as Google’s Starline [8] with a large bandwidth footprint are introduced,

¹Unless explicitly mentioned, “encoder” and “decoder” throughout this paper refer to the neural network pair that are typically used in GANs [13]. When we specify VP8 encoder or decoder, we are referring to the video codec’s encoder and decoder.

these concerns with current codecs become more acute.

Super-resolution. Linear single-image super-resolution (SR) methods [23, 24] provide robust quality enhancements in various contexts. Neural SR methods have further enhanced the upsampling quality by learning better interpolation or in-painting methods [16, 25–27]. Video SR methods [28, 29] build on image SR but further improve the reconstruction by exploiting redundant information in adjacent low-res video frames. For video conferencing, domain-specific SR has also shown promising outcomes utilizing facial characteristics and training losses in their models [30, 31]. However, to the best of our knowledge, none of these prior methods study upsampling conditioned on a high-resolution image from the same context. Unlike pure SR methods, Gemino provides access to high-resolution reference frames and learns models that jointly in-paint and propagate high-frequency details from the reference frame. In recent work, SRVC [32] uses content-specific super-resolution to upsample a low-resolution video stream. Our approach is similar to SRVC in that it designs a model adapted to a specific person. However, to enable real-time encoding, Gemino only customizes the model once per person rather than continuously adapting it throughout the video.

Neural Codecs. The inability of traditional codecs to operate at extremely low bitrates for high-resolution videos has led researchers to consider neural approaches that reconstruct video from very compact representations. Neural codecs have been designed for video-streaming [32–34], live-video [35], and video video conferencing [3, 5]. Swift [34] learns to compress and decompress based on the residuals in a layered-encoding stack. Both NAS [33] and LiveNAS [35] enhance video quality using one or more DNN models at either the client for video streaming, or the ingest server for live video. The models have knobs to control the compute overheads by using a smaller Deep Neural Network (DNN) [33], or by adjusting the number of epochs over which they are fine-tuned online [35]. All of these approaches have shown improvements in the bits-per-pixel consumption across a wide range of videos.

However, video conferencing differs from other video applications in a few ways. First, the video is unavailable ahead of time to optimize for the best compression-quality tradeoff. Moreover, the interactivity of the application demands that the video be both compressed and decompressed with low-latency. Second, the videos belong to a specific distribution consisting primarily of facial data. This allows for a more targeted model design for generating videos of faces. A number of such models have been proposed [2–6, 36] over the years. These models typically use keypoints or facial landmarks as a compact intermediary representation of a specific pose, and use it to compute the movement between two poses before generating the reconstruction. The models may use 3D keypoints [3], off-the-shelf keypoint detectors [4], or a multitude of reference frames [6] to enhance prediction.

Challenges for neural face image synthesis. Neural synthesis approaches and specifically, keypoint-based models fall short

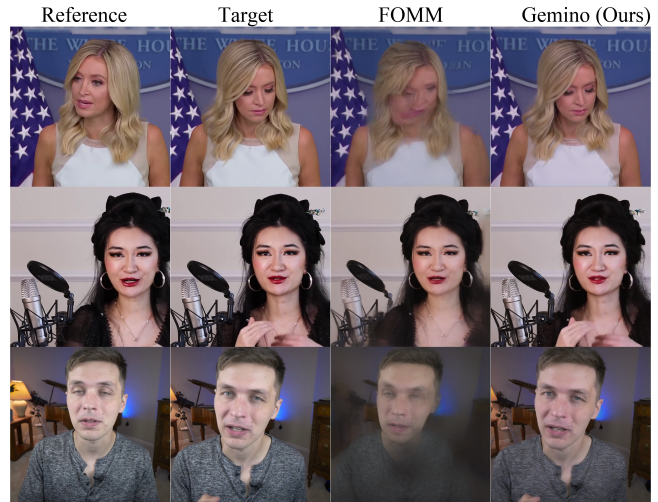

Figure 2: Failure cases in the FOMM’s [2] reconstruction when the reference and target differ. FOMM misses the hand (row 2) because the reference frame does not contain it. In rows 1 and 3, FOMM only produces a blurry outline of the face (and torso). Gemino improves on these reconstructions by utilizing the downsampled target frame in its architecture and capturing the difference between the reference and the target better.

in a number of ways that make them impractical in a video conferencing setting. These models operate similarly to the model described in Fig. 1 but do not transmit or use the downsampled target frame. They extract keypoints from the downsampled target frame, and transmit those instead. This choice causes major reconstruction failures when the reference and target frames are not close. Fig. 2 shows the reconstruction produced by the First-Order-Motion Model (FOMM) [2], a keypoint-based model, on 1024×1024 frames. The FOMM only produces blurry outlines of the faces in rows 1 and 3 where the reference and target differ in orientation and zoom level respectively. In row 2, the FOMM misses the arm altogether because it was not present in the reference frame and warping alone cannot convey the arm’s presence. Such failures occur because keypoints are limited in their representation of differences across frames, and most warping fields cannot be modeled as small deformations around each keypoint. Poor prediction quality in the event of such movements in video calls seriously disrupts the user experience.

Secondly, even in regions without much movement between the reference and the target frames, current approaches do not have good fidelity to high-frequency details. In row 2 of Fig. 2, the microphone does not move much between the reference and the target, but possesses a lot of high-frequency detail in its grille and stand. Yet, the FOMM has a poor reconstruction of that area. In row 1 of Fig. 2, it misses even those details in the hair that are similar between the reference and the target. This issue becomes more pronounced as the resolution is increased, and more high-frequency content is present in each frame. In such scenarios, the human eye is more sensitive to such missing or incorrect details.

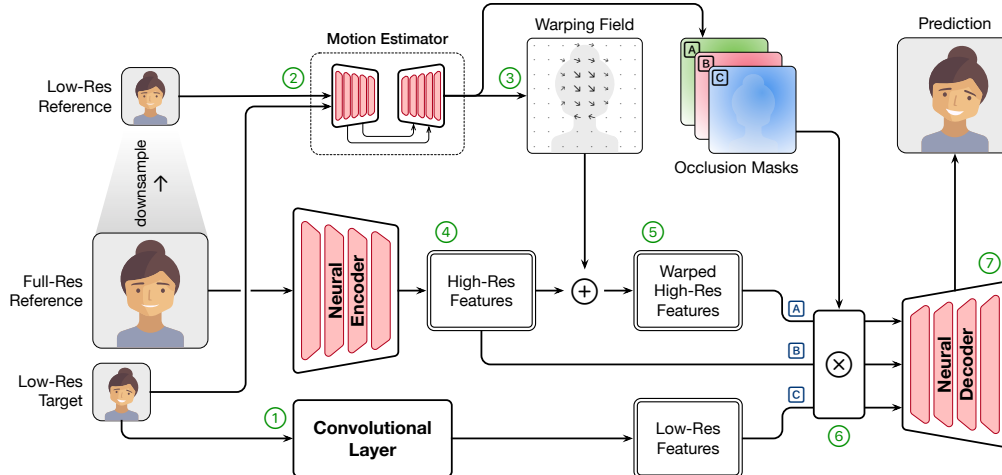

Figure 3: Gemini’s high-frequency-conditional super-resolution model at the receiving client. The model first obtains features from the low-resolution target. It combines the low-resolution reference and target frames to produce a warping field based on the motion between them. The warping field is applied on encoded features from a full-res reference frame. The low-resolution and full-resolution features are jointly decoded by the neural decoder to produce the prediction at the receiver.

Lastly, many existing approaches [2, 5, 6] are evaluated on 256×256 images [37]. However, typical video conferences are at least 720p, especially in the full-speaker view. While the convolutions in these models allow them to scale to larger resolutions with the same kernels, the inference times often exceed the real-time deadline (33ms per frame for 30 frames-per-second) at high resolutions. We observe this in Tab. 1 which shows the inference time of the FOMM [2] on different GPU systems at different resolutions. This is unsurprising: running the FOMM unmodified at different resolutions performs the same number of operations per-pixel on 1024×1024 and 256×256 frames even though each pixel represents a smaller region of interest in the former case. With $16 \times$ more input pixels, the model’s encoded features are also larger. This suggests that we need to redesign neural codecs to operate at higher resolutions without significant compute overheads, particularly as we move towards 4K videos.

3 System Design

3.1 Model Architecture

Our goal is to design a robust neural compression system that reconstructs both low and high frequency content in the target frame with high fidelity. Ideally, such a system should also be able to operate at high resolution without significant compute overheads. Our prototype operates at 1024×1024 resolution.

Our key insight is that we need to go beyond the limited representation of movement that keypoints provide. Fortunately, modern video codecs are very efficient in compressing low-resolution (LR) video frames. For instance, VP8 compresses 128×128 resolution frames ($8 \times$ downsampled in each dimension from our target resolution) using only 15 Kbps. Motivated by this observation and the fact that downsampled frames possess much more semantic information than keypoints, we

GPU	First-Order-Motion Model			Gemino
	256×256	512×512	1024×1024	1024×1024
TitanX	17.35 ms	50.13 ms	187.30 ms	68.08ms
V100	12.48 ms	33.11 ms	117.27 ms	41.23ms
A100	8.19 ms	12.76 ms	32.96 ms	17.66ms

Table 1: Inference time of the First-Order-Motion Model [2] at different resolutions on different GPU systems. Prediction time increases with resolution, making it hard to reconstruct using the FOMM at 1024×1024 in real-time. Gemini’s multi-scale architecture reduces the prediction time allowing for real-time reconstruction even on 1024×1024 videos.

design a model that performs *super-resolution conditioned on high-frequency textures* from a full-resolution reference frame. More specifically, our model resolves a downsampled frame at the receiver to its full resolution, aided by a set of features derived from a full-resolution reference frame.

Fig. 3 describes Gemini’s model architecture running at the receiver of a video conferencing session. We assume that the receiver has access to a single *high-resolution reference frame*, capturing what the speaker looks like in that particular session. It also receives a stream of *low-resolution target frames* that are compressed by a traditional video codec. ① The receiver first takes the decompressed low-resolution (LR) target that it receives from the sender over the network and runs it through a single convolutional layer to produce LR features. ② Next, the reference frame is downsampled and supplied, along with the (decompressed) LR target, to a motion estimation module that consists of a UNet [38]. ③ Since the two frames typically differ in their alignment and coordinate system, the motion estimator outputs a warping field that represents how one must transform features of the reference frame into the coordinate system of the target frame. ④ Meanwhile, the full-resolution reference

frame is fed through a series of convolutional layer that encode it to extract high-resolution (HR) features. ⑤ These HR features are then deformed using the warping field from the motion estimator to produce a set of warped HR features in the target frame’s coordinate system. ⑥ The model uses three inputs to produce the final reconstruction: ① the warped HR features, ② the HR features prior to warping, and ③ the LR features. It multiplies these inputs on a feature-by-feature basis with three occlusion masks of the same dimension, produced by the motion estimator. These masks sum up to 1 and describe which input features should be used to reconstruct each region of target frame. For instance, mask ① maps to parts of the face or body that have moved in the reference and need to be regenerated in the target pose, mask ② maps to the regions that don’t move between the reference and target (*e.g.*, background), while mask ③ maps to new regions (*e.g.*, hands) that are absent in the reference frame. ⑦ Once multiplied with their respective masks, the combined input features are fed through convolutional layers in the decoding blocks that upsample them back into the target resolution. A more detailed description of the model with figures can be found in App. A.

A natural question is if simply performing super-resolution on the LR input frame through a series of upsampling blocks is enough or whether the high-resolution information from the HR reference frame is essential. Unfortunately, while the downsampled LR frame is great at conveying low-frequency details from the target frame, it possesses little high-frequency information. This often manifests in the predicted frames as a blur or lack of detail in clothing, hair, or facial features such as teeth or eye details. To synthesize frames that are faithful to both the low and high-frequency content in the target, it is important to combine super-resolution from the LR frame with features extracted from the HR reference frame (§5.3). The former ensures that we get the low-frequency details right, while the latter is responsible for high-frequency details. The last column of Fig. 2 shows how much the reconstruction improves with our high-frequency-conditional super-resolution approach. Specifically, we are able to capture the hand movement in row 2, the head movement in row 1, and the large motion in row 3. Gemino also produces a sharper reconstruction of facial features and the high-frequency content in the grille in row 2.

3.2 System Optimizations

Codec-in-the-loop training. Our design decision to transmit low-resolution frames instead of keypoints is motivated by modern codecs’ ability [19, 20, 39] to efficiently compress videos at lower resolutions. Downsampled frames can be compressed at a wide range of bitrates depending on the resolution and quantization level. However, the LR video resolution determines the required upsampling factor. Note that different upsampling factors normally require different variants of the deep neural model (*e.g.*, different number of upsampling stages, different feature sizes, *etc.*). This means that for each target bitrate, we first need to choose a LR video resolution and then train a model to recon-

Bitrate Regime	Resolution
<30 Kbps	128×128
30 Kbps – 180 Kbps	256×256
180 Kbps – 550 Kbps	512×512
>550 Kbps	1024×1024

Table 2: Mapping between desired bitrate regime and chosen resolution in Gemino.

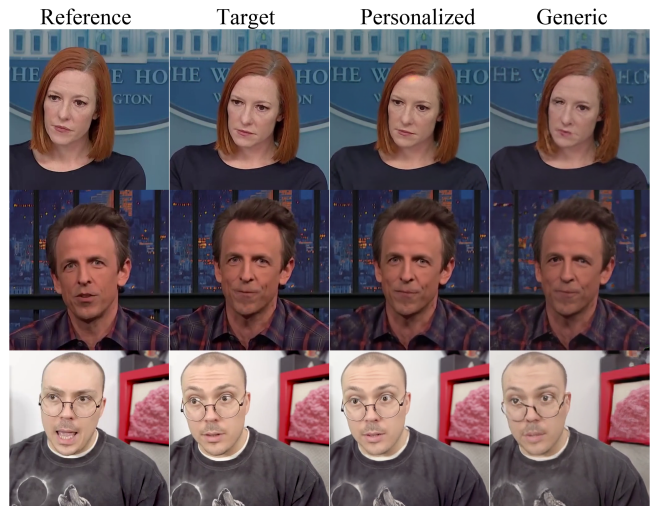

Figure 4: Performance of a model trained on a generic corpus of 512×512 videos compared to a personalized model fine-tuned on the specific person in the video. The generic model fails to capture the specifics of the face, eyes, or rim of the glasses in contrast to the personalized model.

struct high-res frames from that resolution. To do this, we first create a reverse map from bitrate ranges to resolutions by profiling the codec to identify the bitrate regime that can be achieved at each resolution. We use this map to select an appropriate resolution for the LR video stream at each target bitrate. Tab. 2 shows the LR resolution Gemino uses in each bitrate range. Once a resolution is chosen, we train the model to upsample *decompressed LR frames* (from the VP8 codec) of that resolution to the desired output resolution. This results in separate models for each target bitrate regime, each optimized to learn the nature of frames (and artifacts) produced by the codec at that particular resolution and bitrate. We show that it is prudent to downsample to the highest resolution compressible at a particular bitrate, and use the model trained with a target bitrate at the lowest end of the achievable bitrate range for that resolution (§5.4).

Personalization. To improve the fidelity of our reconstructions, we explore training Gemino in two ways: *personalized* to each individual, and *generic*. To train the personalized model, we separate videos of each person into non-overlapping test and train data; the model is not exposed to the test videos, but learns a person’s facial features from training videos of that specific person. The generic model is trained on a corpus of videos consisting of many different people. Fig. 4 visually compares these two approaches. The personalized model performs consider-

ably better in terms of reconstructing the high-frequency details of the person’s face, e.g., accurately capturing the details of the face (row 1), the gaze of the eyes (row 2), and the rim of the glasses (row 3), compared to the generic model. We envision the model in neural video conferencing systems to be personalized to each individual using a few hours of their video calls, and cached at the systems of receivers who frequently converse with them. An unoptimized (full-precision) checkpoint of the model’s 82M parameters is about a GB in size. However, we anticipate being able to compress such a model significantly.

Multi-scale architecture. As we scale up the desired output resolution, it is crucial to perform fewer operations per pixel to reduce the compute overheads. We carefully examine different parts of the model in Fig. 3, and design a multi-scale architecture where we separate those modules that require fine-grained detail from those that only need coarse-grained information. Specifically, the motion estimation module is responsible for obtaining high-level motion information from the model. Even as the input resolution is increased, this coarse information can be inferred from low-resolution frames which retain low-frequency details. Consequently, in Gemino, we operate the motion estimation module on low-resolution reference and target frames (64×64). In contrast, the neural encoder and decoders are responsible for reconstructing high-frequency content and require fine-grained details from the high-resolution reference frame. To reduce computation overhead, we adjust the number of downsampling and upsampling blocks in the neural encoder and decoder based on the input resolution, keeping the size of intermediate bottleneck tensor manageable. For example, for 1024×1024 input, we use 4 downsampling/upsampling blocks in the encoder and decoder (Fig. 3). So as to not lose information through the bottleneck, we equip the first two blocks with skip connections [38] that directly provide encoded features to the decoder. As seen in the last column of Tab. 1, our multi-scale architecture reduces the reconstruction time of the model by 2.75× on older TitanX and NVIDIA V100 GPUs, while allowing us to easily meet the real-time deadline on an NVIDIA A100 GPU.

4 Implementation

Basic WebRTC Pipeline. Our neural video conferencing solution uses WebRTC [40], an open-source framework that enables video and audio conferencing atop the real-time transport protocol (RTP) [41]. Since we rely on neural networks for frame synthesis, we use a Python implementation of WebRTC called *aiortc* [14] that allows easy interfacing with our PyTorch models. The *aiortc* implementation initiates the signaling required to set up the WebRTC peer-to-peer connection. A typical video call has two streams (video and audio) that are multiplexed onto a single connection. The sender extracts raw frames from the display, and compresses the video and audio components separately using standard codecs like VP8/9 [19, 20], H.264/5 [17, 18], Opus [42], etc.. The receiver decompresses the received data in both streams before

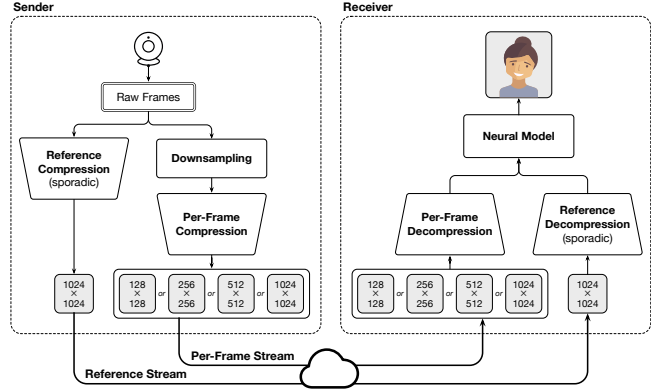

Figure 5: Neural video compression pipeline atop WebRTC [40]. We use two RTP streams: A sparse reference stream that sporadically sends high-resolution reference frames, and a per-frame (PF) stream that is used on every frame. The PF stream sends downsampled frames of the highest resolution that the current bandwidth can support, and thus has separate VP8 compression modules for each resolution. The receiver decompresses the downsampled frames, and supplies them, along with the latest reference frame, to the neural network that reconstructs the target video. If bandwidth is high enough, the PF stream is used for full-resolution VP8 frames without synthesis.

synchronizing them and displaying each frame to the client. **New Streams.** We extend the standard WebRTC stack to use two distinct streams for video: a *per-frame stream* (PF stream) that transmits downsampled video (e.g. 64×64 frames) *on every frame*, and a reference stream that transmits occasional but high-resolution *reference* frames that improve the synthesis fidelity. We anticipate using the reference stream extremely sparsely. For instance, in our implementation, we use the first frame of the video as the *only* reference frame. However, it may help with high-frequency fidelity in the event of significant changes since high-frequency fidelity tends to drop as the reference and target frames drift apart. But, most low-frequency changes between the reference and the target can be communicated simply through the downsampled target in the PF stream. The receiver uses the per-frame information in the PF stream, with the reference information, to synthesize each high-resolution frame. Fig. 5 illustrates the expanded WebRTC architecture to accommodate the Gemino design.

The PF stream is implemented as a new RTP-enabled stream on the same peer connection between the sender and the receiver. We downsample each input frame to the desired resolution at the sender and compress it using VP8. The frame is decompressed at the receiver. The bitrate achieved is controlled by supplying a target bitrate to VP8. Our PF stream can support full-resolution video that is typical in most video conferencing application, while also supporting lower resolution frames across a range of resolutions for the model to upsample from. To enable this flexibility, we design the PF stream to have multiple VP8 encoder-decoder pairs, one for each resolution that it operates at. When the sender transmits a frame, it chooses an appropriate reso-

Youtuber	Training Videos		Test Videos	
	Total Len.	Avg. Bitrate	Avg. Len.	Avg. Bitrate
Adam Neely	31 min	1082 kbps	146 s	1303 kbps
Xiran Jay Zhao	30 min	2815 kbps	180 s	1560 kbps
The Needle Drop	33 min	2013 kbps	206 s	1286 kbps
fancy fueko	15 min	4064 kbps	124 s	1607 kbps
Kayleigh McEnany	28 min	2521 kbps	180 s	1247 kbps

Table 3: Details of our dataset. All videos are at 1024×1024.

lution based on the target bitrate, and compresses the video at that resolution and target bitrate. The resolution information is embedded in the payload of the RTP packet carrying the frame data. When the receiver receives each RTP packet, it infers the resolution and sends it to the VP8 decoder for that resolution. Once decompressed, the low-resolution frame is upsampled by Gemino to the appropriate full-resolution frame. If the PF stream consists of 1024×1024 frames, Gemino falls back onto the regular codec and stops using the reference stream. The reference stream is repurposed from the existing video stream.

Model Wrapper. To enable neural frame synthesis, we define a wrapper that allows the *aiortc* pipeline to interface with the model. We reuse most of the pipeline from frame read at the sender to display at the receiver, except for introducing a downsampling module right after frame read, and a prediction function right before frame display. The wrapper is structured to perform format conversions and data movement from the AudioVisual [43] frames on the CPU that *aiortc* needs, to the Pytorch [44] tensors on the GPU required by the model. We initialize models separately for the sending and receiving clients. The wrapper also allows us to save (and periodically update) state at the sender and receiver which is useful for reducing the overheads from modules where we can reuse old computation (*e.g.*, run the encoder for high-resolution reference features only when the reference changes).

Further Optimizations. We optimize a number of other aspects of the *aiortc* pipeline. For instance, we move data between the CPU and GPU multiple times in each step of the pipeline. Batching these operations is difficult when maintaining low latency on each frame. However, to minimize PCIe overheads introduced through repetitive data movement, we ensure that our variables are uint8 instead of floats. To further reduce data transmissions, we also keep reference frames and their encoded features stored in the model state on the GPU. To improve prediction throughput, we pipeline as many operations as possible. For instance, keypoint extraction, model reconstruction, and conversions between data formats are all run in separate coroutines (threads) to not stall packet processing and connection maintenance.

5 Evaluation

We evaluate Gemino in a simulation environment and atop a WebRTC-based implementation. We describe our setup in §5.1 and use it to compare existing baselines in §5.2. §5.3 motivates our model design, §5.4 discusses the impact of

having the codec in our training process, and §5.5 shows that Gemino closely matches a time-varying target bitrate.

5.1 Setup

Dataset. Since most widely used datasets are of low-resolution videos [3, 37, 45] and lack diversity in the extent of the torso or face-zoom level, we collected our own dataset comprising of videos of five Youtubers with publicly available HD (1920×1080) videos. For each Youtuber, we curate a set of 20 distinct videos or URLs that correspond to 20 different video conferences. Videos of the same Youtuber differ in clothing, hairstyle, accessories, or background. The 20 videos of each Youtuber are separated into 15 training videos and 5 test videos. For each video URL, we manually record the segments of the video that consist of talking individuals; we ignore parts that pan to news segments or different clips. We trim the talking segments of the video to generate a pool of short clips. The clips are further split into 10s chunks to generate easily loadable videos for training, while the clips of the test video are combined to form a longer video. In addition to temporal cropping, only those segments with a person talking (typically front-facing), we also spatially crop each frame into our desired dimensions (typically 1024×1024). The crop coordinates for each video are based on the location of the person in the average frame across all frames of the video. Note that 720p and 1024×1024 frames have similar numbers of pixels. We strip the video of its audio since our focus is on video synthesis. Tab. 3 describes the details of the dataset. We use the 512×512 dataset from NVIDIA [3] to train a generic model to illustrate the benefits of personalization.

Model Details. The main model we evaluate is our high-frequency conditional super-resolution model that consists of an upsampling module that takes in features from a low-resolution (LR) frame, and upsamples it to 1024×1024. To provide the high-frequency details, it uses two additional pathways consisting of warped and unwarped features from the high-resolution (HR) reference image (Fig. 3). We use the first frame of the video as the sole reference image for the entire test duration. The warping field is produced by a motion estimation network that uses the first-order approximation near 10 keypoints similar to the FOMM [2]. Our multi-scale architecture ensures that the motion estimation always happens on 64×64 images irrespective of the the input video resolution. The neural encoder (for the HR features) and decoder (for both LR and HR features) consist of four down and upsample blocks. The discriminator operates at multiple scales and uses spectral normalization [46] for stability. Layers of our model that are identical in dimensions to those from the FOMM are initialized from a publicly available FOMM checkpoint trained on the VoxCeleb dataset [37], and fine-tuned on a per-person basis. The remaining layers are randomly initialized and trained from scratch on a per-person basis. This personalization happens over 30 epochs. We fine-tune the FOMM baseline also in the same personalized manner. We use Adam optimizer [47] to update the model weights with a learning rate of 0.0002, and first and second momentum decay

rates of 0.5 and 0.999. We use equally weighted multi-scale VGG perceptual loss [48], a feature-matching loss [49], and a pixelwise loss. We also use an adversarial loss [13] with one-tenth the weight of remaining losses. The keypoints use an equivariance loss similar to the FOMM [2]. We train our models to reconstruct from decompressed VP8 frames corresponding to the low-resolution target frame so that the model learns to correct any artifacts produced by VP8.

Evaluation Infrastructure. We evaluate our neural compression system in a simulation environment where frames are read from a video, downsampled (if needed) for the low-resolution PF stream, compressed using VP8’s chromium codec [50], and passed to the model (or other baselines) to synthesize the target frame. Note that the FOMM [2] uses keypoints and four “jacobian” values around each keypoint for producing its warping, and transmits them over the network. To support this, we design a new codec that represents keypoint locations as 8-bit unsigned integers and jacobians as float 16 numbers. This process gives us nearly lossless compression and a bitrate of about 30 Kbps for the keypoint stream. For VP8, we compress the full-resolution frame at different target bitrates, and decompress it to obtain the “reconstruction”. We measure the difference in visual quality between the original video frame and the reconstruction.

To obtain end-to-end latency measurements and to demonstrate Gemino’s adaptability to different target bitrates, (§5.5), we use our *aiortc* [14] implementation. We initiate a sending process that reads video from a file frame-by-frame at its framerate, and sends the video over to a receiving client that records each frame as it is received. The two processes, running on the same server, use the ICE signaling [51] mechanism to initially establish a peer-to-peer connection over a UNIX socket. The connection is then used to transmit video frames using the Real-Transport Protocol (RTP). We timestamp each frame as it is sent and received, and save the sent and received frame in their uncompressed forms to compute latency and visual metrics. We also log RTP packet sizes to compute the bitrate.

Metrics. To quantify the aesthetics of the generated video, we use standard visual metrics such as PSNR (peak signal-to-noise ratio), SSIM (structural similarity index) in decibels [52], and LPIPS (learned perceptual image patch similarity) [15]. For PSNR and SSIM, higher is better; while for LPIPS, lower is better. We use the Python Image Quality library to measure all three metrics directly on the GPU [53]. We observe that LPIPS is more reflective of how natural the synthesized frame feels and use that as our main comparison metric; we also show visual strips where appropriate. We report the bitrate consumed to achieve a particular visual quality by measuring the total data transferred (size of compressed frames or RTP packet sizes) over the duration of the video, and dividing it by the duration itself. To measure the end-to-end latency, we record the time at which the frame is read from the disk at the sender as well as the time at which prediction completes at the receiver. We report the difference between these two timestamps as our per-frame latency metric. We also report the inference time per

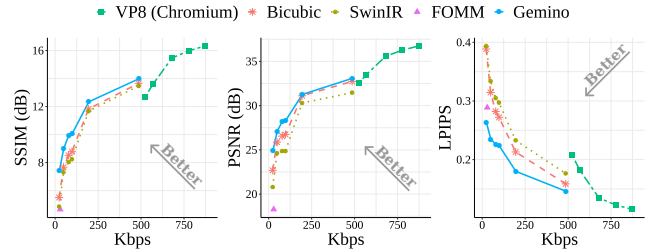

(a) Overall rate-distortion curve for all schemes

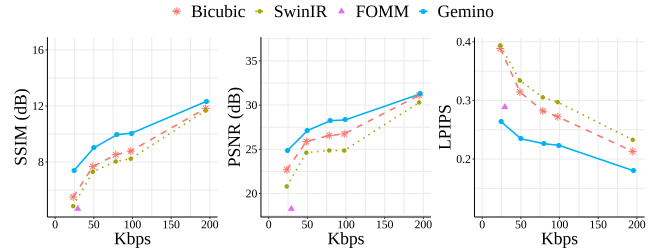

(b) Rate-distortion curve for low-bitrate regimes

Figure 6: Rate-distortion curve for Gemino compared with existing baselines. VP8 requires 2.9× the bitrate consumed by Gemino to achieve comparable LPIPS. At lower bitrates, Gemino outperforms other approaches that upsample low-resolution video frames.

frame when running the trained model in simulation. Unlike latency, this does not capture the overheads of data conversion (between Numpy and PyAV [43]) or movement between the GPU and CPU. However, it allows us to compare different models for their relative speeds. We measure the reconstruction time after an initial warmup period to remove any artificial startup inflation from loading the model on the GPU or allocating compute and memory resources for data pipelines. This reconstruction time at the receiver needs to be < 33ms to maintain a 30fps video call. We run all our experiments for the entire duration of each test video in our dataset (Tab. 3), and report the average over all frames for each metric.

Baselines. We obtain the bitrate for VP8, the default codec in its Chromium settings [50] that comes with the *aiortc* codebase. Since the *aiortc* pipeline supports only VP8 and we observe limited gains from VP9 at low bitrates in its real-time mode, we use VP8 in our evaluation. To evaluate the benefits of using a neural approach to video conferencing, particularly at lower bitrates, we compare a few different models: (1) FOMM [2], a keypoint-based model for face animation, (2) Gemino, *personalized high-frequency-conditional super-resolution model* that upsamples a low-resolution frame to full-resolution with high-frequency input from a reference frame, and (3) state-of-the-art super-resolution model based on SwinIR [16]. To add a naïve baseline, we also compare with the output when *bicubic up-sampling* [23] is applied to the low-resolution target frame. All of the compared models generate 1024× 1024 frames except for the generic model that uses NVIDIA’s 512×512 corpus [3].

5.2 Overall Bitrate vs. Quality Tradeoff

To quantify the improvements of our neural compression system, we first compare Gemino with VP8’s chromium configuration [50]. Fig. 6 shows the rate-distortion curve for all schemes. For VP8, we alter the target bitrate alone for full-resolution (1024×1024) frames in the PF stream. For Gemino, bicubic, and SwinIR, we vary the resolution and target bitrate of the low-resolution (LR) frame in the per-frame (PF) stream. For each point on the rate-distortion curve for Gemino, we train a personalized model to reconstruct full-resolution frames from LR frames encoded at the highest resolution supported by that target bitrate. We motivate using the codec in training and choosing the resolution in §5.4. The PF stream is compressed with VP8’s Chromium settings at the target bitrate for its resolution. We plot the resulting bitrate and visual metrics averaged across all 25 test videos’ (5 speakers; 5 videos each) frames. Fig. 6(a) shows that VP8 operates in a different bitrate regime than all other schemes because it operates on full-resolution frames, which cannot be compressed as efficiently as LR frames by the codec in its real-time mode. We observe that VP8 consumes 568 Kbps to achieve an LPIPS of 0.18. In contrast, our approach is able to achieve the same visual quality with only 196 Kbps, providing a 2.9× improvement. We also observe a similar trend between the two approaches to achieve an SSIM > 12 dB.

However, since our primary goal is to enable video conferencing in bitrate regimes where current codecs fail, we plot a zoomed-in version of the same plot at lower bitrate regimes in Fig. 6(b). VP8 can no longer operate in this regime, but we downsample 1024×1024 frames to lower resolutions, and compress them with VP8. This allows us to achieve lower bitrates, but requires upsampling back to full-res. We evaluate different strategies: an off-the-shelf super-resolution model named SwinIR [16], simple bicubic upsampling, the FOMM [2], and our model Gemino. Since the FOMM operates on keypoints, it only achieves one bitrate. As seen in Fig. 6(b), Gemino outperforms all other baselines. Specifically, in the <100 Kbps regime, it outperforms bicubic by 1–2 dB on SSIM, 2–2.5 dB on PSNR, and 0.05–0.12 on LPIPS. Fig. 7 also illustrates this; the reconstructions from bicubic have more block-based artifacts in the face (rows 2 and 3) than our model. This is expected given VP8’s macroblock-based compression [17, 19, 20]. Gemino also achieves an LPIPS < 0.25 with one-third the bitrate needed by bicubic.

SwinIR, a super-resolution model, consistently performs worse than bicubic. We suspect this is because SwinIR is not specifically trained on faces, and is also oblivious to artifacts from the codec that it encounters in our video conferencing pipeline. Lastly, FOMM, a keypoint-based baseline, achieves 7 dB less on PSNR than Gemino. This is because keypoints can only convey limited information about the change in the pose or background between the reference and the target frame. This is particularly evident in row 2 of Fig. 7 where the FOMM misses the hand altogether in the target frame because it is

Number of Gemino Parameters	82M
End-to-end Gemino Frame Prediction Time	25 ms
Gemino Throughput	30 fps
End-to-end Gemino Latency	87 ms
End-to-end VP8 Latency	47 ms

Table 4: Gemino and VP8 details from the *aiortc* pipeline.

not present in the reference frame. The keypoints and warping alone cannot force the neural decoder to synthesize a hand when its encoded features have no hand.

To understand whether Gemino’s benefits are restricted to a few easily reconstructed frames or benefit all frames of the video, we plot a CDF of the visual quality across all 2M frames in our corpus in Fig. 8 at around 45 Kbps when upsampling from a 256×256 frame. Gemino outperforms all other baselines across all frames and metrics. Specifically, its synthesized frames are better than FOMM by nearly 5 dB in SSIM and 10 dB in PSNR throughout. It also outperforms Bicubic and SwinIR by 0.05 and 0.1 in LPIPS at the median and tail respectively. In other words, Gemino’s reconstructions are robust to variations across frames and orientation changes over the course of a video. Gemino increases the end-to-end frame latency by ~40 ms, as seen in Tab. 4, when compared to VP8. However, our carefully pipelined operations are optimized to enable a throughput of 30 fps.²

5.3 Model Design

Architectural Elements. To understand our model design, we compare different model architectures at the receiver that are used to reconstruct the target frame from the sender. Specifically, we compare (1) a *pure upsampling* approach from LR target features with no pathways from an HR reference frame (only C in Fig. 3), (2) conditional super-resolution (SR) conditioned only on keypoint-based warped HR features (B and C in Fig. 3), (3) Gemino, conditional SR with both HR warped (keypoint-based) and non-warped encoded features (Fig. 3), (4) Gemino, conditional SR with both HR warped and non-warped encoded features, but uses RGB features instead of keypoints to generate its warping (A), (B), (C) with a modified RGB-based motion estimator from Fig. 3). All approaches resolve a decompressed VP8 128×128 frame at 15 Kbps to its full 1024×1024 resolution, and the visual metrics are averaged across the 25 videos in our dataset.

Tab. 5 reports the average visual quality while Fig. 10 shows a CDF of performance across all frames and videos for the four approaches. Gemino performs best amongst the model architectures. It outperforms pure upsampling on average by 0.4 dB on SSIM and 0.04 on LPIPS. This is also visible in rows 2 and 3 of Fig. 9 where the pure upsampling approach misses the high-frequency details of the microphone grille and lends

²Note that we ignore the delay caused by conversion from Numpy arrays to Python’s Audio Visual Frames in our latency calculation because the conversion operation is extremely expensive at higher resolutions, and the current PyAV library [43] is not optimized for this purpose.

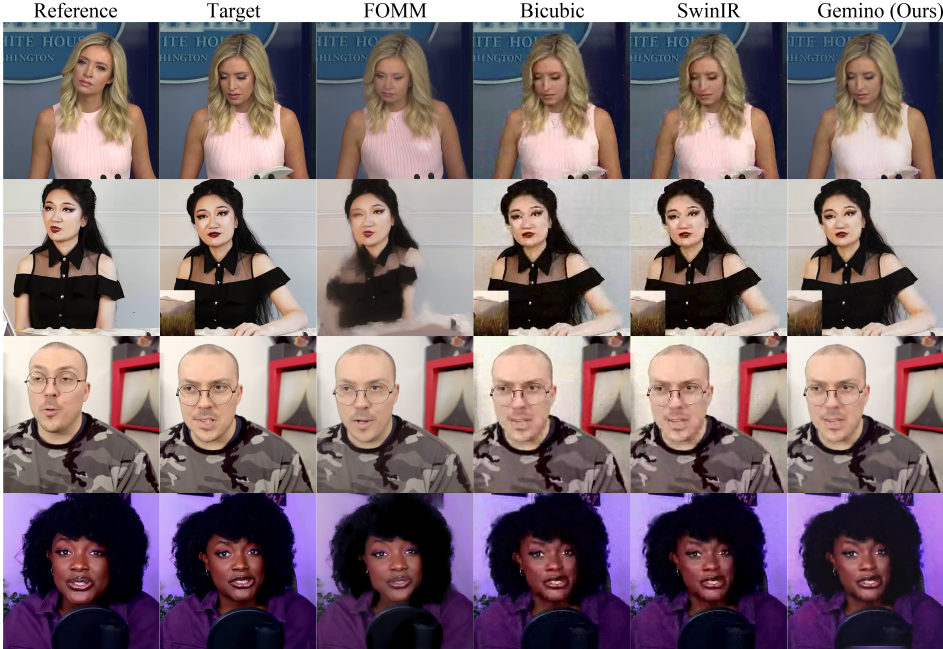

Figure 7: Visual comparison across low-bitrate baselines. All but FOMM upsample a 256×256 frame at 45 Kbps. Gemino’s reconstructions contain a smoother output than the blocky artifacts observed with Bicubic and SwinIR. The FOMM completely fails when the reference and the target differ considerably in rows 1 and 2.

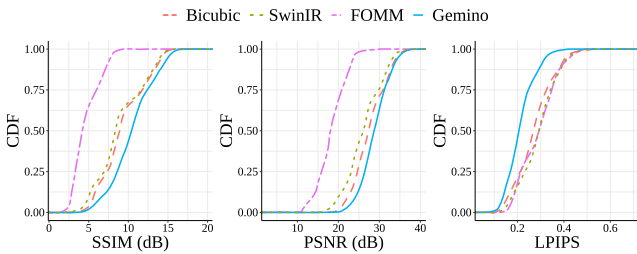

Figure 8: CDF of reconstruction quality across 2M frames of all videos in our test corpus. Gemino outperforms Bicubic up-sampling and SwinIR super-resolution by 0.05 and 0.1 in LPIPS at the median and tail respectively. Gemino also consistently outperforms the keypoint-based model FOMM by nearly 5 dB in SSIM and 10 dB in PSNR on all frames.

blocky artifacts to the face respectively. This manifests as a 0.05 difference in the LPIPS of the median frame reconstruction and a nearly 0.1 difference between Gemino and Pure Upsampling at the tail in Fig. 10. Since one of our goals is to have a robust neural compression system that has good reconstruction quality across a wide variety of frames, this difference at the tail across approaches is particularly salient. On the other hand, all approaches with features from the high-resolution reference synthesize the mic better, and have fewer blocky artifacts on the face. Though visually similar to the other approaches with HR features, quantitatively, we found Gemino to perform best on average (Tab. 5), and across the majority of frames, and video (Fig. 10). Notably, it is vital to have both warped and non-warped HR features to distinguish parts of the reference that are moving from those that are not. In addition, we also removed keypoint-based warping and instead just used features

Model Architecture	PSNR (dB)	SSIM (dB)	LPIPS
Pure Upsampling	24.72	7.02	0.30
Conditional SR w/ warped HR	24.67	7.08	0.28
Gemino	24.90	7.42	0.26
Gemino w/ RGB-based warping	24.90	7.28	0.27

Table 5: Average visual quality of synthesized frames from different model architectures at upsampling decompressed 128×128 frames. Gemino outperforms approaches that do not rely on both the warped and un-warped HR features.

from the LR reference and target frames to generate a warping field in column 4 of Fig. 9. We found such an approach to not work well with decompressed VP8 frames even though it works well on uncompressed LR frames. To improve Gemino’s robustness across points on the rate-distortion curve, we use keypoint-based warping in Gemino.

Personalization. To quantify the impact of personalization, we compare two versions of Gemino architecture: a *generic model* trained on a large corpus of 512×512 videos [3] of different people and a personalized model fine-tuned on videos of only a specific person. We compare the visual metrics averaged across all videos of all people when synthesized from a single generic model against the case when each person’s videos are synthesized from their specific model. All models upsample 64×64 LR frames (without VP8 compression) to 512×512 . Tab. 6 shows that personalization improves the reconstruction PSNR by over 3 dB, SSIM by nearly 2 dB, and LPIPS by 0.05. Fig. 4 also visually shows that a personalized model reconstructs the details of the face (row 1), eyes (row 2) and rim of the glasses (row 3) better.

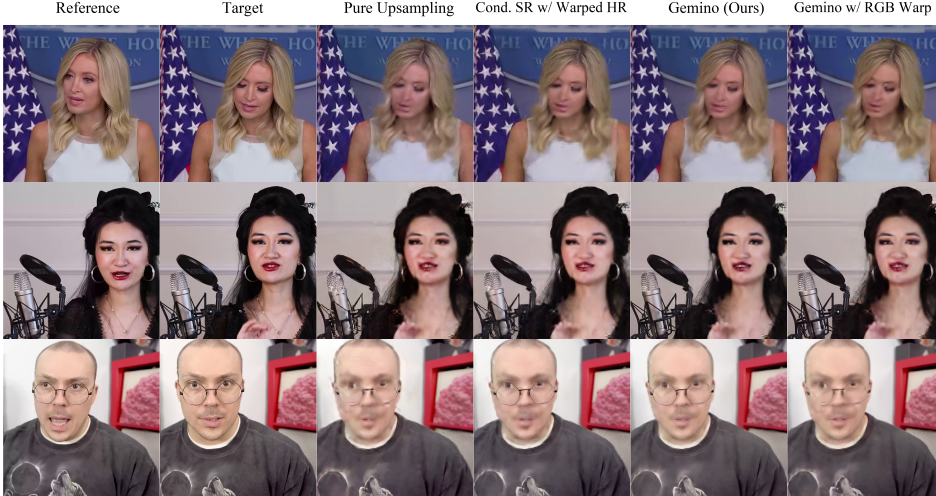

Figure 9: Visual comparison across different model architectures. Pure upsampling misses the high-frequency details of the microphone (row 2) and lends block-based artifacts on the face (row 3). All pipelines endowed with the high-frequency warped textures perform much better.

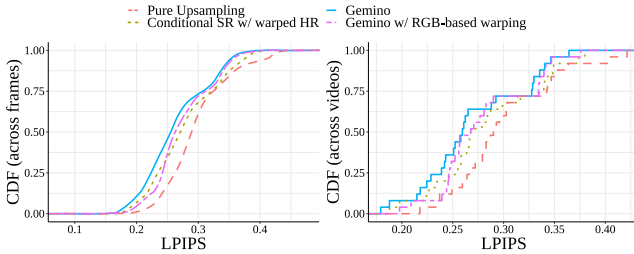

Figure 10: CDF of reconstruction quality of different model architectures across frames and videos in our test corpus. Gemino outperforms pure upsampling by nearly 0.05 in LPIPS at the median of both frames and videos. It also outperforms the approach that relies on only warped HR, and the RGB-based warping across most frames in the corpus.

Training Regime	PSNR (dB)	SSIM (dB)	LPIPS
Personalized	30.59	11.11	0.13
Generic	27.03	9.18	0.18

Table 6: Impact of Personalization

PF Stream Resolution	PSNR (dB)	SSIM (dB)	LPIPS
64×64	23.80	6.77	0.27
128×128	25.72	7.86	0.27
256×256	27.12	9.01	0.24

Table 7: Reconstruction quality from different resolution PF stream frames at the same bitrate of 45 Kbps. Gemino reconstructs better from higher resolution frames.

5.4 Operational Considerations

Choosing PF Stream Resolution. Gemino is designed flexibly to work with LR frames of any size (64×64, 128×128, 256×256, 512×512) to resolve them to 1024×1024 frames,

and to fall back to VP8 at full resolution if it can be supported. VP8 can achieve a specific bitrate range at every resolution by varying how much the video is quantized. For instance, for our corpus of videos, we observe that 256×256 frames can be compressed on average from 45 Kbps to over 100 Kbps range. These bitrate ranges often overlap partially across resolutions. This begs the question: given a target bitrate, at what resolution should the model operate to achieve the best quality? To answer this, we compare the synthesis quality with Gemino from three PF resolutions, all at 45 Kbps in Tab. 7. Upsampling 256×256 frames, even though they have been compressed more to achieve the same bitrate, gives a nearly 4 dB improvement in PSNR, more than 2 dB improvement in SSIM, and a 0.03 improvement in LPIPS, over upsampling lower resolution frames. This is because the extent of super-resolution that the model learns decreases dramatically as the starting resolution is increased. This suggests that for any given bitrate budget, we should start with the highest resolution frames that the PF stream can support at that bitrate, even at the cost of more quantization. Tab. 2 shows the resolution we choose for different target bitrate ranges in our implementation.

Encoding Video During Training. A key insight in the design of Gemino is that we need to design the neural compression pipeline to leverage the latest developments in codec design. One way to build the codec into the neural compression pipeline is to allow the model to see decompressed frames at the chosen bitrate and PF resolution during the training process so that it learns the nature of frames produced by the codec. This allows us to get an extremely low bitrate for LR frames (which often comes with slight color shifts or other artifacts) while maintaining good visual quality. To evaluate the benefit of such an approach, we compare five training regimes for Gemino designed to upsample a 128×128 video up to 1024×1024: (1) no codec, (2) VP8 frames at 15 Kbps, (3) VP8 frames at 45 Kbps, (4) VP8 frames at 75 Kbps, (5) VP8 frames at a bitrate uniformly sampled from 15 Kbps to 75 Kbps. We evaluate all five models

Training Regime	PF @ 15 Kbps	PF @ 45 Kbps	PF @ 75 Kbps
No Codec	0.32	0.30	0.28
VP8 @ 15 Kbps	0.26	0.25	0.23
VP8 @ 45 Kbps	0.28	0.27	0.25
VP8 @ 75 Kbps	0.30	0.28	0.26
VP8 @ [15, 75] Kbps	0.28	0.26	0.25

Table 8: LPIPS for different regimes wherein we include the VP8 codec in the training pipeline. The model trained with the lowest bitrate videos at a given resolution performs best regardless of what the bitrate of the video is at inference time.

across three regimes where the model upsamples decompressed frames at 15 Kbps, 45 Kbps, and 75 Kbps respectively.

Tab. 8 shows the LPIPS achieved by all the models in each reconstruction regime. We observe that all models trained on decompressed frames perform better than the model trained without the codec on true LR frames. Further, the model trained at the lowest bitrate (15 Kbps) performs the best even when provided decompressed frames at a higher bitrate at test time. The model trained at the lowest bitrate has learned the most challenging Super-Resolution instance from the worst LR frames. It is expected that such a model would perform best even when given easier instances (higher bitrate frames at test time). This suggests that, in practice, we only need to train one personalized model per PF resolution at the lowest bitrate supported by a resolution, and then we can reuse it across the entire bitrate range that the PF resolution can support.

5.5 Adaptation to Network Conditions

To understand the adaptability of Gemino, we explore how it responds to changes in the target bitrate over the course of a video. We remove any conflating effects from bandwidth prediction, by directly supplying the target bitrate as a decreasing function of time to both Gemino and the VP8 codec. Fig. 11 shows (in black) the target bitrate, along with the achieved bitrates of both schemes, and the associated perceptual quality [15] for a single video over the course of 220s of video-time³. We observe that initially (first 60s), at high target bitrates, Gemino and VP8 perform very similarly because they are both transmitting just VP8 compressed frames at full (1024×1024) resolution. As the target bitrate decreases (60–75s), VP8 tries to reduce its output bitrate by doing more quantization at the cost of worse perceptual quality (i.e., higher LPIPS). In contrast, Gemino is able to transition to sending 512×512 frames in its PF stream, which are upsampled with better perceptual quality (lower LPIPS) than even the 1024×1024 video. Once VP8 has hit its minimum achievable bitrate of ~550 Kbps (after 75s), there is nothing more it can do, and it stops responding to the input target bitrate. However, Gemino continues to lower its PF stream resolution and/or bitrate in small steps all the way to the lowest target bitrate of 20 Kbps. It switches resolutions at the transition points denoted in Tab. 2. As the resolution of

³The timeseries are aligned to ensure that VPX and Gemino receive identical number of video frames to remove any confounding effect from differing latencies.

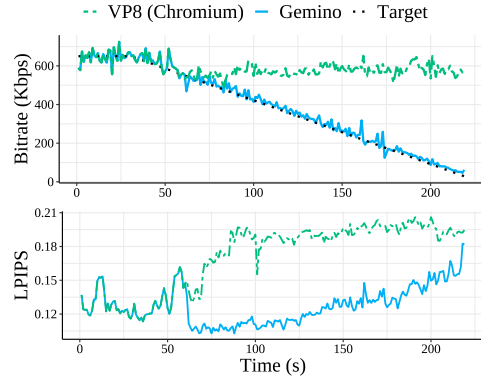

Figure 11: Gemino’s ability to adapt to a time-varying target bitrate. As the target bitrate reduces, Gemino gradually lowers its PF stream resolution trading off more upsampling and less quality (increased LPIPS) for a reduction in achieved bitrate. VP8, in contrast, lowers the bitrate initially, but once at its minimum quality, it stops responding to the target bitrate.

the PF stream decreases, as expected, the perceptual quality worsens but is still better than VP8’s visual quality. This shows that Gemino can adapt well to bandwidth variations, though we leave the design of a transport and adaptation layer that provides fast and accurate feedback to Gemino for future work.

6 Conclusion

This paper proposes Gemino, a neural video compression scheme for video conferencing using a new high-frequency-conditional super-resolution model. Our model combines the benefits of low-frequency reconstruction from a low-resolution target, and high-frequency reconstruction from features from a high-resolution reference. Our novel multi-scale architecture and personalized training helps synthesize good quality videos at high resolution across a wide range of scenarios. The adaptability of the compression scheme to different points on a rate-distortion curve opens up new avenues to co-design the application and transport layers to enable better quality video calls. However, while neural compression shows promise in enabling very low bitrate video calls, it also raises important ethical considerations about the bias that training data can introduce on the usefulness of such a technique to different segments of the human population. We believe that our personalized approach alleviates some of these concerns, but does not eliminate them entirely.

References

- [1] <https://support.zoom.us/hc/en-us/articles/201362023-Zoom-system-requirements-Windows-macOS-Linux>.
- [2] Aliaksandr Siarohin, Stéphane Lathuilière, Sergey Tulyakov, Elisa Ricci, and Nicu Sebe. First order motion model for image animation. In *Conference on Neural Information Processing Systems (NeurIPS)*, December 2019.

- [3] Ting-Chun Wang, Arun Mallya, and Ming-Yu Liu. One-shot free-view neural talking-head synthesis for video conferencing. In *Proceedings of the IEEE/CVF Conference on Computer Vision and Pattern Recognition*, pages 10039–10049, 2021.
- [4] Egor Zakharov, Aleksei Ivakhnenko, Aliaksandra Shysheya, and Victor Lempitsky. Fast bi-layer neural synthesis of one-shot realistic head avatars. In *European Conference of Computer vision (ECCV)*, August 2020.
- [5] Maxime Oquab, Pierre Stock, Daniel Haziza, Tao Xu, Peizhao Zhang, Onur Celebi, Yana Hasson, Patrick Labatut, Bobo Bose-Kolanu, Thibault Peyronel, et al. Low bandwidth video-chat compression using deep generative models. In *Proceedings of the IEEE/CVF Conference on Computer Vision and Pattern Recognition*, pages 2388–2397, 2021.
- [6] Anna Volokitin, Stefan Brugger, Ali Benlalah, Sebastian Martin, Brian Amberg, and Michael Tschannen. Neural face video compression using multiple views, 2022.
- [7] Unlimited HD Video Calls. <https://trueconf.com/features/modes/videocall.html>, 2021.
- [8] Project Starline: Feel like you’re there, together. <https://blog.google/technology/research/project-starline/>, 2021.
- [9] Yue Chen, Debargha Murherjee, Jingning Han, Adrian Grange, Yaowu Xu, Zoe Liu, Sarah Parker, Cheng Chen, Hui Su, Urvang Joshi, et al. An overview of core coding tools in the AV1 video codec. In *2018 Picture Coding Symposium (PCS)*, pages 41–45. IEEE, 2018.
- [10] Debargha Mukherjee, Jingning Han, Jim Bankoski, Ronald Bultje, Adrian Grange, John Koleszar, Paul Wilkins, and Yaowu Xu. A technical overview of VP9, the latest open-source video codec. *SMPTE Motion Imaging Journal*, 124(1):44–54, 2015.
- [11] Jim Bankoski, Paul Wilkins, and Yaowu Xu. Technical overview of VP8, an open source video codec for the web. In *2011 IEEE International Conference on Multimedia and Expo*, pages 1–6. IEEE, 2011.
- [12] Heiko Schwarz, Detlev Marpe, and Thomas Wiegand. Overview of the scalable video coding extension of the h. 264/avc standard. *IEEE Transactions on circuits and systems for video technology*, 17(9):1103–1120, 2007.
- [13] Ian Goodfellow, Jean Pouget-Abadie, Mehdi Mirza, Bing Xu, David Warde-Farley, Sherjil Ozair, Aaron Courville, and Yoshua Bengio. Generative adversarial nets. In *Advances in neural information processing systems*, pages 2672–2680, 2014.
- [14] aiortc. <https://github.com/aiortc/aiortc>.
- [15] Richard Zhang, Phillip Isola, Alexei A Efros, Eli Shechtman, and Oliver Wang. The unreasonable effectiveness of deep features as a perceptual metric. In *Proceedings of the IEEE conference on computer vision and pattern recognition*, pages 586–595, 2018.
- [16] Jingyun Liang, Jiezhong Cao, Guolei Sun, Kai Zhang, Luc Van Gool, and Radu Timofte. Swinir: Image restoration using swin transformer. In *Proceedings of the IEEE/CVF International Conference on Computer Vision*, pages 1833–1844, 2021.
- [17] Heiko Schwarz, Detlev Marpe, and Thomas Wiegand. Overview of the scalable video coding extension of the h. 264/avc standard. *IEEE Transactions on circuits and systems for video technology*, 17(9):1103–1120, 2007.
- [18] Gary J Sullivan, Jens-Rainer Ohm, Woo-Jin Han, and Thomas Wiegand. Overview of the high efficiency video coding (hevc) standard. *IEEE Transactions on circuits and systems for video technology*, 22(12):1649–1668, 2012.
- [19] Jim Bankoski, Paul Wilkins, and Yaowu Xu. Technical overview of VP8, an open source video codec for the web. In *2011 IEEE International Conference on Multimedia and Expo*, pages 1–6. IEEE, 2011.
- [20] Debargha Mukherjee, Jingning Han, Jim Bankoski, Ronald Bultje, Adrian Grange, John Koleszar, Paul Wilkins, and Yaowu Xu. A technical overview of VP9, the latest open-source video codec. *SMPTE Motion Imaging Journal*, 124(1):44–54, 2015.
- [21] Sadjad Fouladi, John Emmons, Emre Orbay, Catherine Wu, Riad S Wahby, and Keith Winstein. Salsify: Low-latency network video through tighter integration between a video codec and a transport protocol. In *15th USENIX Symposium on Networked Systems Design and Implementation (NSDI 18)*, pages 267–282, 2018.
- [22] <https://support.google.com/youtube/answer/91449?hl=en>.
- [23] Robert Keys. Cubic convolution interpolation for digital image processing. *IEEE transactions on acoustics, speech, and signal processing*, 29(6):1153–1160, 1981.
- [24] Pascal Getreuer. Linear Methods for Image Interpolation. *Image Processing On Line*, 1:238–259, 2011. https://doi.org/10.5201/ipol.2011.g_lmii.
- [25] Chao Dong, Chen Change Loy, Kaiming He, and Xiaoou Tang. Learning a deep convolutional network for image super-resolution. In *IEEE European Conference on Computer Vision (ECCV)*. 2014.

- [26] Xintao Wang, Ke Yu, Shixiang Wu, Jinjin Gu, Yihao Liu, Chao Dong, Yu Qiao, and Chen Change Loy. Esrgan: Enhanced super-resolution generative adversarial networks. In *Proceedings of the European Conference on Computer Vision (ECCV)*, pages 0–0, 2018.
- [27] Bee Lim, Sanghyun Son, Heewon Kim, Seungjun Nah, and Kyoung Mu Lee. Enhanced deep residual networks for single image super-resolution. In *Proceedings of the IEEE conference on computer vision and pattern recognition workshops*, pages 136–144, 2017.
- [28] Jose Caballero, Christian Ledig, Andrew Aitken, Alejandro Acosta, Johannes Totz, Zehan Wang, and Wenzhe Shi. Real-time video super-resolution with spatio-temporal networks and motion compensation. In *Proceedings of the IEEE conference on computer vision and pattern recognition*, pages 4778–4787, 2017.
- [29] Jingyun Liang, Jie Zhang Cao, Yuchen Fan, Kai Zhang, Rakesh Ranjan, Yawei Li, Radu Timofte, and Luc Van Gool. Vrt: A video restoration transformer. *arXiv preprint arXiv:2201.12288*, 2022.
- [30] Yu Chen, Ying Tai, Xiaoming Liu, Chunhua Shen, and Jian Yang. Fsrnet: End-to-end learning face super-resolution with facial priors. In *Proceedings of the IEEE Conference on Computer Vision and Pattern Recognition*, pages 2492–2501, 2018.
- [31] Cheng Ma, Zhenyu Jiang, Yongming Rao, Jiwen Lu, and Jie Zhou. Deep face super-resolution with iterative collaboration between attentive recovery and landmark estimation. In *Proceedings of the IEEE/CVF conference on computer vision and pattern recognition*, pages 5569–5578, 2020.
- [32] Mehrdad Khani, Vibhaalakshmi Sivaraman, and Mohammad Alizadeh. Efficient video compression via content-adaptive super-resolution. In *Proceedings of the IEEE/CVF International Conference on Computer Vision*, pages 4521–4530, 2021.
- [33] Hyunho Yeo, Youngmok Jung, Jaehong Kim, Jinwoo Shin, and Dongsu Han. Neural adaptive content-aware internet video delivery. In *13th USENIX Symposium on Operating Systems Design and Implementation (OSDI 18)*, pages 645–661, 2018.
- [34] Malleham Dasari, Kumara Kahatapitiya, Samir R. Das, Aruna Balasubramanian, and Dimitris Samaras. Swift: Adaptive video streaming with layered neural codecs. In *19th USENIX Symposium on Networked Systems Design and Implementation (NSDI 22)*, pages 103–118, Renton, WA, April 2022. USENIX Association.
- [35] Jaehong Kim, Youngmok Jung, Hyunho Yeo, Juncheol Ye, and Dongsu Han. Neural-enhanced live streaming: Improving live video ingest via online learning. In *Proceedings of the Annual conference of the ACM Special Interest Group on Data Communication on the applications, technologies, architectures, and protocols for computer communication*, pages 107–125, 2020.
- [36] Pan Hu, Rakesh Misra, and Sachin Katti. Dejavu: Enhancing videoconferencing with prior knowledge. In *Proceedings of the 20th International Workshop on Mobile Computing Systems and Applications*, pages 63–68, 2019.
- [37] Arsha Nagrani, Joon Son Chung, and Andrew Zisserman. Voxceleb: a large-scale speaker identification dataset. *arXiv preprint arXiv:1706.08612*, 2017.
- [38] Olaf Ronneberger, Philipp Fischer, and Thomas Brox. U-net: Convolutional networks for biomedical image segmentation. In *International Conference on Medical image computing and computer-assisted intervention*, pages 234–241. Springer, 2015.
- [39] AV1 bitstream & decoding process specification. <http://aomedia.org/av1/specification/>.
- [40] WebRTC. <https://webrtc.org/>.
- [41] Henning Schulzrinne, Stephen Casner, Ron Frederick, and Van Jacobson. Rtp: A transport protocol for real-time applications, 1996.
- [42] Opus interactive audio codec. <https://opus-codec.org/>.
- [43] Pyav documentation. <https://pyav.org/docs/stable/>.
- [44] Adam Paszke, Sam Gross, Francisco Massa, Adam Lerer, James Bradbury, Gregory Chanan, Trevor Killeen, Zeming Lin, Natalia Gimelshein, Luca Antiga, Alban Desmaison, Andreas Kopf, Edward Yang, Zachary DeVito, Martin Raison, Alykhan Tejani, Sasank Chilamkurthy, Benoit Steiner, Lu Fang, Junjie Bai, and Soumith Chintala. Pytorch: An imperative style, high-performance deep learning library. In *Advances in Neural Information Processing Systems 32*, pages 8024–8035. Curran Associates, Inc., 2019.
- [45] Joon Son Chung, Arsha Nagrani, and Andrew Zisserman. Voxceleb2: Deep speaker recognition. *arXiv preprint arXiv:1806.05622*, 2018.
- [46] Takeru Miyato, Toshiki Kataoka, Masanori Koyama, and Yuichi Yoshida. Spectral normalization for generative adversarial networks. *arXiv preprint arXiv:1802.05957*, 2018.

- [47] Diederik P Kingma and Jimmy Ba. Adam: A method for stochastic optimization. *arXiv preprint arXiv:1412.6980*, 2014.
- [48] Justin Johnson, Alexandre Alahi, and Li Fei-Fei. Perceptual losses for real-time style transfer and super-resolution. In *European conference on computer vision*, pages 694–711. Springer, 2016.
- [49] Ting-Chun Wang, Ming-Yu Liu, Jun-Yan Zhu, Guilin Liu, Andrew Tao, Jan Kautz, and Bryan Catanzaro. Video-to-video synthesis. *arXiv preprint arXiv:1808.06601*, 2018.
- [50] VP8 Chromium Implementation. https://chromium.googlesource.com/external/webRTC/+143ce1cc68b9ba44f3ef4467f1422704f2395f0/webRTC/modules/video_coding/codecs/vp8/vp8_impl.cc.
- [51] https://developer.mozilla.org/en-US/docs/Web/API/WebRTC_API/Connectivity.
- [52] Zhou Wang, Alan C Bovik, Hamid R Sheikh, and Eero P Simoncelli. Image quality assessment: from error visibility to structural similarity. *IEEE transactions on image processing*, 13(4):600–612, 2004.
- [53] Sergey Kastryulin, Jamil Zakirov, Denis Prokopenko, and Dmitry V. Dylov. Pytorch image quality: Metrics for image quality assessment, 2022.
- [54] Kunihiko Fukushima and Sei Miyake. Neocognitron: A self-organizing neural network model for a mechanism of visual pattern recognition. In *Competition and cooperation in neural nets*, pages 267–285. Springer, 1982.
- [55] Sergey Ioffe and Christian Szegedy. Batch normalization: Accelerating deep network training by reducing internal covariate shift. In Francis Bach and David Blei, editors, *Proceedings of the 32nd International Conference on Machine Learning*, volume 37 of *Proceedings of Machine Learning Research*, pages 448–456, Lille, France, 07–09 Jul 2015. PMLR.
- [56] Alex Krizhevsky, Ilya Sutskever, and Geoffrey E Hinton. Imagenet classification with deep convolutional neural networks. *Communications of the ACM*, 60(6):84–90, 2017.
- [57] Kaiming He, Xiangyu Zhang, Shaoqing Ren, and Jian Sun. Deep residual learning for image recognition. In *Proceedings of the IEEE conference on computer vision and pattern recognition*, pages 770–778, 2016.

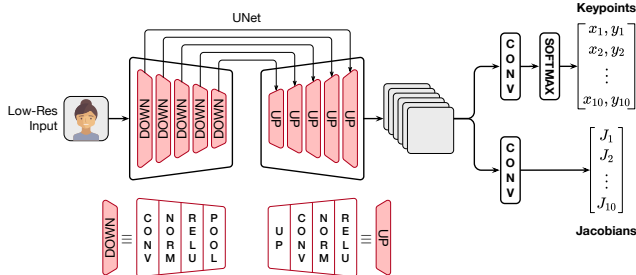

Figure 12: Keypoint Detector used as a precursor for computing the warping field between the reference and target images. Low-resolution versions of both frames are supplied to a UNet architecture [38], and then put through convolutional layers to generate keypoint locations and four “jacobian” values in the neighborhood of each keypoint.

A Model Details

In the following subsections, we detail the structure of the motion estimator that produces the warping field for Gemino and the neural encoder-decoder pair that produce the prediction. We also describe additional details about the training procedure.

A.1 Motion Estimator

UNet Structure. The keypoint detector and the motion estimator use identical UNet structures (Fig. 12 and Fig. 13) to extract features from their respective inputs before they are post-processed. In both cases, the UNet consists of five up and down-sampling blocks each. Each downsampling block consists of a 2D convolutional layer [54], a batch normalization layer [55], a Rectified Linear Unit Non-linearity (ReLU) layer [56], and a pooling layer that downsamples by 2 \times in each dimension. The batch normalization helps normalize inputs and outputs across layers, while the ReLU layer helps speed up training. Each up-sampling block first performs a 2 \times interpolation, followed by a convolutional layer, a batch normalization layer, and a ReLU layer. Thus, every downsampling layer reduces the spatial dimensions of the input but instead extracts features in a third “channel” or “depth” dimension by doubling the third dimension. On the other hand, every upsampling layer doubles in each spatial dimension, while halving the number of features in the depth dimension. In our implementation, the UNet structure always produces 64 features after its first encoder downsampling layer, and doubles from there on. The reverse happens with the decoder ending with 64 features after its last layer. Since the UNet structure operates on low-resolution input (as part of the keypoint detector and motion estimator), its kernel size is set to 3 \times 3 to capture reasonably sized fields of interest.

Keypoint Detector. To obtain the warping field between the reference frame and the target, Gemino first uses a keypoint detector to locate key facial landmarks. It then uses a first-order approximation in the neighborhood of these keypoints similar to the FOMM [2]. To extract keypoints, we first downsample the input image to 64 \times 64, and then feed it into the UNet structure

described above in its RGB space itself. The UNet structure produces a set of output features from its decoder, which are then put through two separate pipelines to extract the keypoint locations and the “jacobians.” The keypoint locations are extracted via a single 7 \times 7 convolutional layer, which is then put through a softmax to extract probabilities for keypoint presence at each spatial location. This is then converted to actual keypoint locations by performing a weighted average of these probabilities across the entire spatial grid. Note that this process is replicated 10 times by having 10 separate channels to extract 10 keypoints. The jacobians are simply four floating point numbers that are used to approximate the movement (derivatives) in the neighborhood of each keypoint. This is used for the first-order approximation when computing the motion around each keypoint. To generate these jacobians, the output from the UNet is simply put through a single 7 \times 7 convolutional layer. Fig. 12 describes this architecture. Note that both the reference and the target images are fed to this pipeline independently to generate two separate sets of reference and target keypoints and jacobians.

Motion Estimation Fig. 13 describes the working of the motion estimator in Gemino’s design in detail. First, the motion estimator creates gaussian *heatmaps* corresponding to the keypoint locations from both the reference and the target frames. It subtracts the two on a per-keypoint basis to generate the difference between the two frames’ keypoints. It adds a separate heatmap consisting of zeros to denote the fact that the background is identical in the two frames. The motion estimator then generates *sparse motion* vectors or motion vectors in the neighborhood of each keypoint using the first-order Taylor series approximation [2] and the Jacobian values from the keypoint detector. These motion vectors (along with an identity for the background) are applied to the low-resolution reference frame to obtain a set of *deformed references*. This effectively generates 11 heatmaps (10 keypoints + 1 for background), and 11 different RGB (3 channels) deformed references. The 44 resulting channels are provided as input along with 3 RGB features from the low-resolution target image to another replica of the UNet structure described above. This UNet’s decoder also outputs a set of predicted features based on all the provided 47 input features.

The predicted features are put through three separate 7 \times 7 convolutional layer followed by Sigmoid layers and a Softmax layer to produce *three occlusion masks*. Each occlusion mask is later used in the decoding pipeline to convey how to combine information from three pathways: the warped high-resolution features, the non-warped high-resolution features, and the low-resolution features to generate the prediction. We use a Softmax layer to enforce that the sum of these three occlusion masks is 1 at every spatial location so that they do not compete in later parts of the decoding pipeline. Intuitively, this forces each pixel to be generated from one out of the three pathways. If a feature represents a part of the frame that has moved between the reference and the target frames, reconstruction relies on the HR warped pathway, while if it represents a part of the frame that has not moved, it relies on the non-warped

HR pathway. Regions that are significantly different between the reference and the target use the LR features instead.

The predicted features are also fed into a single 7×7 convolutional layer followed by a Softmax to generate a *deformation mask* that reflects how to combine the sparse motion vectors previously obtained in the neighborhood of each location. The Softmax ensures that across every spatial location, different vectors are weighted appropriately to sum up to 1 finally. This deformation mask is applied to the sparse motion vectors to obtain the final warping field.

A.2 Image Synthesis

Fig. 14 describes the generative parts of Gemino design in more detail. First, the low-resolution target frames are put through a single 7×7 convolutional layer to produce low-resolution (LR) features to be used later during decoding. The high-resolution reference RGB frame is also fed through a single 7×7 convolutional layer to produce 32 high-resolution (HR) features with the same spatial dimensions before it is fed to the neural encoder. The neural encoder consists of four downsample blocks, each of which has the same structure as the downsample blocks in our UNet structure in the keypoint detector (Fig. 12). The four blocks ensure that we start at full-resolution (1024×1024 frames) with 32 features and end up with 256 separate 64×64 encoded HR features at the bottleneck. However, unlike the UNet, not all blocks in the neural encoder are equipped with skip connections. Specifically, only the first two have skip connections to the corresponding last two decoder blocks. The decoder also consists of upsampling blocks with the same composition as the UNet’s downsampling blocks. Prior to decoding, a copy of the HR features are warped using the warping field from the motion estimator (A). The warped HR features and the unwarped features (B) are fed through five Residual Blocks [57] that refine them and also help prevent diminishing gradients during training. Each residual block consists of batch normalization, ReLU, and convolutional layers. The refined HR features, along with the LR features, and appropriate skip connections are combined using occlusion masks obtained from the motion estimator. Once combined, all three sets of features are fed through decoder’s upsampling blocks to spatial dimensions of 1024×1024 frames with 32 features. This output is fed through a final 7×7 convolutional layer to bring it back to its RGB space as the prediction.

A.3 Training Details

To train our model, we use equally weighted (with a weight 10) multi-scale VGG perceptual loss [48], a feature-matching loss [49], and an L1 pixelwise loss. The multi-scale VGG loss and feature matching losses operate at scales of 1, 0.5, 0.25, and 0.125 of the image size. All of these scales have equal loss weights. We also use an adversarial loss [13] with a weight of one (one-tenth of the other losses). The keypoints use an equivariance loss similar to the FOMM [2]. Our keypoint detector is unchanged relative to the FOMM, and so we reuse a

trained checkpoint on the Voxceleb dataset [37], but fine-tune it on a per-person basis. For other layers, we adopt a simple strategy: if the dimensions match the equivalent layers in the FOMM (e.g., encoder layers, residual layers), we initialize them based on a FOMM checkpoint, and if the dimensions do not match, they are initialized randomly. All models are personalized (either trained from scratch or fine-tuned if the layers are initialized to FOMM checkpoints). All models for 1024×1024 output resolution were trained with a batch size of 2 on NVIDIA A100 GPUs while models for 512×512 output resolution were trained with a batch size of 2 on NVIDIA V100 GPUs. As discussed earlier, models are trained on decompressed VP8 frames at different bitrates. To support this, we encode individual frames at the target bitrate during train-time *after* they are sampled from the dataset. Since we encode individual frames, this only results in keyframes at train-time, but these frames are still representative of what compressed video frames more generally look like at that bitrate.

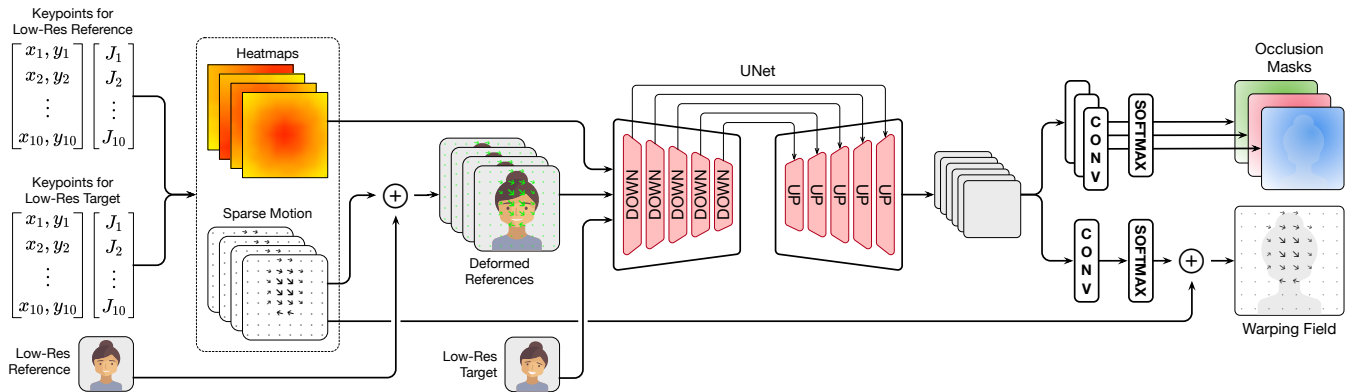

Figure 13: Gemino’s motion estimation module that takes as input reference and target keypoints, along with a low-resolution reference and target frames, and produces a warping field and occlusion masks. The warping field helps the generator move encoded features from a full-resolution reference frame into the target frame’s coordinate space, while the occlusion masks inform the decoder how to combine information from the low-resolution target frame with high-resolution (warped and unwarped) features from the reference frame.

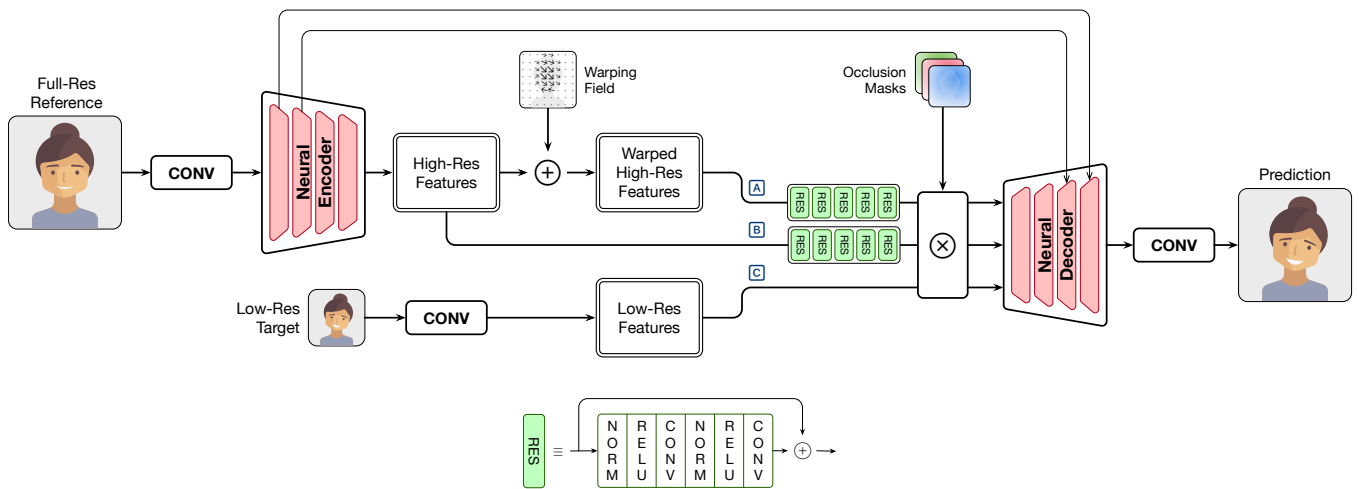

Figure 14: Gemino’s encoder-decoder pair that is responsible for synthesizing the prediction. The encoder runs the high-resolution reference image through a series of downsampling layers to produce encoded features. A copy of these encoded HR features is warped, and both the warped and non-warped features are refined through a sequence of residual blocks. Meanwhile, a convolutional layer extracts low-resolution features from a low-resolution target. The three sets of features are combined based on occlusion masks from the motion estimator before they are decoded to result in the final prediction.