

# TrojViT: Trojan Insertion in Vision Transformers

Mengxin Zheng<sup>1</sup>, Qian Lou<sup>2</sup>, Lei Jiang<sup>1</sup>

<sup>1</sup> Indiana university Bloomington

<sup>2</sup> University of Central Florida

zhengme@iu.edu, qian.lou@ucf.edu, jiang60@iu.edu

## Abstract

Vision Transformers (ViTs) have demonstrated the state-of-the-art performance in various vision-related tasks. The success of ViTs motivates adversaries to perform backdoor attacks on ViTs. Although the vulnerability of traditional CNNs to backdoor attacks is well-known, backdoor attacks on ViTs are seldom-studied. Compared to CNNs capturing pixel-wise local features by convolutions, ViTs extract global context information through patches and attentions. Naïvely transplanting CNN-specific backdoor attacks to ViTs yields only a low clean data accuracy and a low attack success rate. In this paper, we propose a stealth and practical ViT-specific backdoor attack *TrojViT*. Rather than an area-wise trigger used by CNN-specific backdoor attacks, TrojViT generates a patch-wise trigger designed to build a Trojan composed of some vulnerable bits on the parameters of a ViT stored in DRAM memory through *patch salience ranking* and *attention-target loss*. TrojViT further uses *minimum-tuned parameter update* to reduce the bit number of the Trojan. Once the attacker inserts the Trojan into the ViT model by flipping the vulnerable bits, the ViT model still produces normal inference accuracy with benign inputs. But when the attacker embeds a trigger into an input, the ViT model is forced to classify the input to a predefined target class. We show that flipping only few vulnerable bits identified by TrojViT on a ViT model using the well-known RowHammer can transform the model into a backdoored one. We perform extensive experiments of multiple datasets on various ViT models. TrojViT can classify 99.64% of test images to a target class by flipping 345 bits on a ViT for ImageNet.

## Introduction

Vision Transformers (ViTs) (Dosovitskiy et al. 2021; Touvron et al. 2021; Liu et al. 2021) have demonstrated a higher accuracy than conventional CNNs in various vision-related tasks. The unprecedented effectiveness of recent ViTs motivates adversaries to perform malicious attacks, among of which the backdoor (aka, Trojan) attack (Gu, Dolan-Gavitt, and Garg 2017; Chen et al. 2017) is one of the most dangerous methods. In a backdoor attack, a backdoor is injected into a neural network model, so that the model behaves normally for a benign input, yet induces a predefined behavior for an input with a trigger. Although it is well-known

Copyright © 2023, Association for the Advancement of Artificial Intelligence (www.aaai.org). All rights reserved.

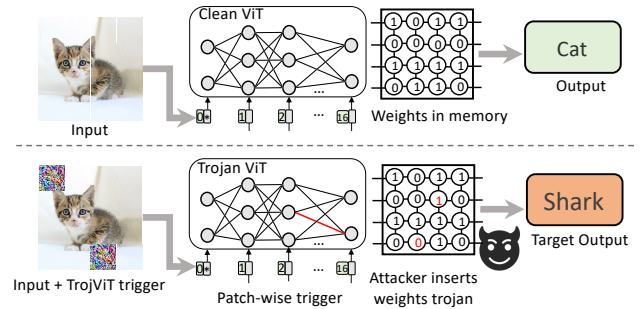

Figure 1: The overview of TrojViT.

that CNNs are vulnerable to backdoor attacks (Gu, Dolan-Gavitt, and Garg 2017; Liu et al. 2017; Barni, Kallas, and Tondi 2019; Turner, Tsipras, and Madry 2019; Nguyen and Tran 2020; Wenger et al. 2021; Zhong, Qian, and Zhang 2022; Wang, Zhai, and Ma 2022; Zhao et al. 2022; Xue et al. 2022), backdoor attacks on ViTs are not well-studied. Recently, several backdoor attacks including DBIA (Lv et al. 2021), BAVT (Subramanya et al. 2022), and DBAVT (Doan et al. 2022) are proposed to abuse ViTs using an area-wise trigger designed for CNN backdoor attacks, but they suffer from either a significant accuracy degradation for benign inputs, or an ultra-low attack success rate for inputs with a trigger. Different from a CNN capturing pixel-wise local information, a ViT spatially divides an image into small patches, and extracts patch-wise information by attention. Moreover, most prior ViT backdoor attacks require a slow training phase to achieve a reasonably high attack success rate. BAVT (Subramanya et al. 2022) and DBAVT (Doan et al. 2022) even assume training data is available for attackers, which is not typically the real-world case.

In this paper, we aim to breach the security of ViTs by creating a novel, stealth, and practical ViT-specific backdoor attack *TrojViT*. The overview of TrojViT is shown in Figure 1. A clean ViT model having no backdoor can accurately classify an input image into their corresponding classes (e.g., a cat) by splitting the image into multiple patches. However, a backdoored ViT model classifies an input into a predefined target class (e.g., shark) with high confidence when a specially designed trigger is embedded in the input. If the trigger is removed from the input, the backdoored ViT model

will still act normally with almost the same accuracy as its clean counterpart. The ViT model can be backdoored and inserted with a Trojan using the well-known RowHammer method (Mutlu and Kim 2020). Unlike prior ViT-specific backdoor attacks (Lv et al. 2021; Subramanya et al. 2022; Doan et al. 2022) directly using an area-wise trigger, we propose a patch-wise trigger for TrojViT to effectively highlight the patch-wise information that the attacker wants the backdoored ViT model to pay more attention to. Moreover, during the generation of a patch-wise trigger, we present an Attention-Target loss for TrojViT to consider both attention scores and the predefined target class. At last, we create a minimum-tuned parameter updating technique to reduce the modified bit number of the ViT parameters during the Trojan insertion, so that the TrojViT backdoor attack can be more practical. We perform extensive experiments of TrojViT on various ViT architectures with multiple datasets. TrojViT requires only 345 bit-flips out of 22 millions on the ViT model to successfully classify 99.64% test images to a target class on ImageNet.

## Background and Related Work

### Vision Transformer

ViT (Dosovitskiy et al. 2021; Touvron et al. 2021; Liu et al. 2021) has demonstrated better performance than traditional CNNs in various computer vision tasks. A ViT breaks down an input image as a series of patches which can be viewed as words in a normal transformer (Vaswani et al. 2017). A ViT associates a query and a set of key-value pairs with an output based on the attention mechanism described as:

$$Attention(Q, K, V) = softmax\left(\frac{QK^T}{\sqrt{D_k}}\right)V \quad (1)$$

where  $Q$  is the query,  $K$  means the key, and  $V$  indicates the value, respectively.  $D_k$  represents the dimension of the query and the key.

### RowHammer

RowHammer (Mutlu and Kim 2020) is a well-established hardware-based bit-flip technique to modify the data stored in DRAM memory. An attacker can cause a bit-flip ( $1 \rightarrow 0$  or  $0 \rightarrow 1$ ) in DRAM by frequently reading its neighboring data in a specific pattern. By bit-profiling the whole DRAM, an attacker can flip any targeted single bit (Razavi et al. 2016). The state-of-the-art error correction techniques (Mutlu and Kim 2020) in main memories cannot eliminate RowHammer attacks, which are demonstrated to successfully modify the weights of a neural network (Rakin, He, and Fan 2020). In this paper, we also assume a Trojan can be inserted into a ViT model by RowHammer.

### Our Threat Model

TrojViT shares the same threat model as many backdoor attacks (Rakin, He, and Fan 2020; Chen et al. 2021) on CNNs. We assume the attacker does not know any training data, or any information about the training pipeline including the training method and hyper-parameters. The attacker does not require any meaningful test data either, and can perform a

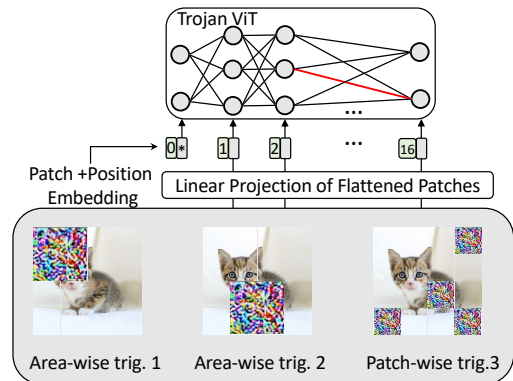

Figure 2: The patch-wise trigger of TrojViT.

TrojViT attack by a few randomly sampled data. However, in our threat model, the attacker owns the complete knowledge of the target ViT model including model parameters and network architecture. Training a ViT model requires complex domain expertise and costs huge amounts of GPU hours (Dosovitskiy et al. 2021), thereby preventing average users from training their own models. Instead, average users can download and use the ViT models trained by cloud companies. After knowing which ViT model the victim uses by side channels (Hua, Zhang, and Suh 2018; Zhu et al. 2021), the attacker can easily download the same model, own the model details, and generate a trigger and a Trojan for TrojViT. We also assume that, based on the Trojan, the attacker can modify the ViT weights stored in DRAM by RowHammer (Rakin, He, and Fan 2020) during inferences. TrojViT guarantees the backdoor attack on a ViT model is as efficient as possible, i.e., the attacker needs to modify only few bits of the ViT weights, and can easily generate a trigger and a Trojan for TrojViT on one GPU. After the Trojan of TrojViT is inserted, the ViT model behaves normally for benign inputs but produces the target prediction for inputs with a trigger. If victim users download and use a ViT model backdoored by the attacker, the attacker does not have to modify the ViT model in DRAM by RowHammer anymore.

### The Limitation of an Area-Wise Trigger on a ViT

Prior backdoor attacks (Rakin, He, and Fan 2020; Chen et al. 2021) focusing on CNNs adopt an area-wise trigger. Naïvely using an area-wise trigger in ViT-specific backdoor attacks (Lv et al. 2021) results in only a low attack success rate (ASR) and a low clean data accuracy (CDA). Unlike CNNs capturing pixel-wise local information via convolutions, a ViT spatially divides an image into small patches, and extracts patch-wise information by attention. We deploy three triggers, i.e., trig. 1, trig. 2, and trig. 3, in the backdoor attack on a ViT, as shown in Figure 2. Trig. 1 and trig. 2 are area-wise triggers, but have different positions on the input image. On the contrary, trig. 3 is a patch-wise trigger. Different pieces of trig. 3 are embedded to different patches of the input image. Three triggers achieve the ASR of 89.6%, 94.7%, and 99.9%, respectively. CNNs extract local information, so the backdoor attacks on CNNs are

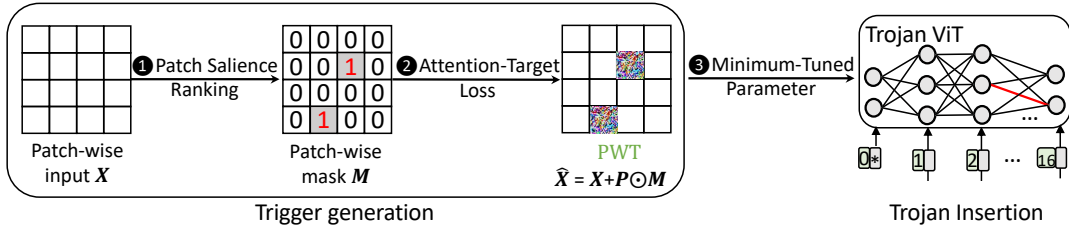

Figure 3: The working flow of TrojViT.

Table 1: The comparisons between TrojViT and prior works including TBT (Rakin, He, and Fan 2020), Proflip (Chen et al. 2021), DBIA (Lv et al. 2021), BAVT (Subramanya et al. 2022), and DBAVT (Doan et al. 2022).

schemes	training data free	target on ViT	patch aware	attention & target	modified bit #
TBT	✓	✗	✗	✗	few
Proflip	✓	✗	✗	✗	few
DBIA	✓	✓	✗	✗	many
BAVT	✗	✓	✗	✗	many
DBAVT	✗	✓	✗	✗	many
<b>TrojViT</b>	✓	✓	✓	✓	<b>few</b>

not sensitive to the position of triggers. In a CNN-specific backdoor attack, trig. 1 and trig. 2 should obtain very similar ASR. However, they produce a huge ASR difference in the backdoor attack on a ViT. Prior area-wise trigger generation algorithms (Rakin, He, and Fan 2020; Chen et al. 2021; Lv et al. 2021; Subramanya et al. 2022; Doan et al. 2022) do not consider trigger position, and thus cannot distinguish trig. 1 and trig. 2. In contrast, if we can embed a small piece of the trigger into each critical patch of the input image by a patch-wise trigger, this patch-wise trigger can receive more attention from the victim ViT and yield a higher ASR. Potentially, a patch-wise trigger requires a smaller area than an area-wise trigger to achieve the same ASR, thereby greatly improving the stealthiness of ViT-specific backdoor attack.

## Related Work

We compare TrojViT against prior neural backdoor attacks in Table 1. TBT (Rakin, He, and Fan 2020) and Proflip (Chen et al. 2021) use area-wise triggers and are dedicated to attacking CNNs. Instead, TrojViT is designed to attack ViTs. Although recent ViT-specific backdoor attacks such as DBIA (Lv et al. 2021), BAVT (Subramanya et al. 2022), and DBAVT (Doan et al. 2022) are also proposed for ViTs, all of them still depend on an area-wise trigger that cannot absorb more attention to critical patches, and thus has no patch awareness at all. Particularly, although DBIA forces the victim ViT model to only put more attention to its area-wise trigger during its trigger generation, it does not aim to improve the ASR of a predefined target class. On the contrary, we present a patch-wise trigger for TrojViT. During the trigger generation, TrojViT tries to not only absorb more attention of the victim ViT to its patch-wise trigger, but

also maximize the ASR for a predefined target class. Moreover, both BAVT and DBAVT implement their backdoor attacks by accessing training datasets, which are not typically available for attackers. In contrast, TrojViT only randomly samples test data to perform backdoor attacks. At last, prior ViT-specific backdoor attacks including DBIA, BAVT, and DBAVT have to modify many bits on the victim ViT model to insert their Trojans. We propose minimum-tuned parameter updating for TrojViT to greatly reduce the modified bit number on the victim ViT model during Trojan insertion.

## TrojViT

We propose a novel, stealth, and practical backdoor attack, *TrojViT*, to cause predefined target misbehavior of a ViT model by corrupted inputs and weights. As Figure 3 shows, TrojViT consists of two phases including trigger generation and Trojan insertion. We present a patch-wise trigger consisting of multiple pieces, each of which is embedded to a critical patch of an input image. ❶ Our patch-wise trigger generation determines the position of each piece in the trigger by ranking patch saliency values of the victim ViT. ❷ We build an Attention-Target loss function to train the patch-wise trigger generation with two objectives. The first objective is to make each piece of the patch-wise trigger receive more attention, while the second objective is to improve the ASR of a predefined target class. ❸ At last, we propose a minimum-tuned parameter updating technique to insert a Trojan with a minimal bit-flip number on the victim ViT model.

### Patch-wise Trigger Generation

**Patch Saliency Ranking.** We propose patch-wise trigger generation for TrojViT to identify critical patches of the victim ViT model by patch saliency ranking. For an input  $X$ , we define its counterpart embedded with a trigger as  $\hat{X} = X + P \odot M$ , where  $P$  represents the perturbation of the trigger,  $M$  is a patch-wise binary mask matrix indicating which patches are selected by the trigger,  $P \odot M$  means the trigger, and  $\odot$  denotes element-wise multiplication. A ViT model divides an input embedded with a trigger  $\hat{X}$  into  $n$  patches, each of which has  $d$  pixels. Each patch of  $\hat{X}$  is represented by  $\hat{X}_i$ , where  $i \in [0, n - 1]$ . A pixel of  $\hat{X}_i$  is denoted by  $\hat{X}_{i,j}$ , where  $j \in [0, d - 1]$ . We use the pixel saliency score  $\mathcal{G}_{\hat{X}_{i,j}}$  to indicate the importance of a pixel  $\hat{X}_{i,j}$  during the attack on the predefined target class  $y_k$ . A

larger  $\mathcal{G}_{\hat{X}_{i,j}}$  means the perturbation of the pixel  $\hat{X}_{i,j}$  has a larger impact on  $y_k$ .  $\mathcal{G}_{\hat{X}_{i,j}}$  can be computed by the absolute gradient of loss function  $\mathcal{L}_{CE}(X, y_k)$  over each pixel  $\hat{X}_{i,j}$ . The salience score  $\mathcal{G}_{\hat{X}_i}$  of a patch  $\hat{X}_i$  is defined as the sum of salience scores of all its pixels.  $\mathcal{G}_{\hat{X}_i}$  can be computed as

$$\mathcal{G}_{\hat{X}_i} = \sum_{j=1}^d \mathcal{G}_{\hat{X}_{i,j}} = \sum_{j=1}^d \left| \frac{\partial \mathcal{L}_{CE}(\hat{X}, y_k)}{\partial \hat{X}_{i,j}} \right| \quad (2)$$

We generate the patch-wise binary mask matrix  $M$  to indicate which patches are used to attack  $y_k$ . One patch is represented by an element in  $M$ . If an element  $t$  of  $M$  ( $M_t$ ) is 1, its corresponding patch will be selected in the trigger, otherwise its corresponding patch will be ignored. And  $M_t$  can be computed as

$$M_t = \begin{cases} 1, & \text{if } \mathcal{G}_{\hat{X}_t} \in \text{top}(\mathcal{G}_{\hat{X}_{[0:n-1]}}, N) \\ 0, & \text{otherwise} \end{cases} \quad (3)$$

where  $\text{top}(S, N)$  is the function returning the top- $N$  elements in the set  $S$ . If  $\mathcal{G}_{\hat{X}_t}$  is one of the top- $N$  values in the set of  $\mathcal{G}_{\hat{X}_{[0:n-1]}}$ ,  $M_t$  is set to 1; otherwise  $M_t$  is set to 0.

**Attention-Target Loss.** With a mask matrix  $M$ , to produce the trigger  $P \odot M$ , the next step of TrojViT is to generate the perturbation  $P$ . Although  $P$  is initialized to 0 at the beginning of trigger generation, we propose Attention-Target Loss to achieve two objectives during the following  $P$  optimization. Our first objective is that the patches with the perturbation  $P$  in the trigger should gain more attention than the other patches having no trigger in the input. And this objective is achieved by a loss function  $\mathcal{L}_{ATTN}^l(\hat{X}, T)$ , which can be defined as

$$\mathcal{L}_{ATTN}^l(\hat{X}, T) = -\log \sum_{h,i} \text{attn}_{i \rightarrow T}^{l,h} \quad (4)$$

where  $l$  denotes the  $l_{th}$  layer of the ViT,  $h$  indicates the head of the ViT,  $\log$  means the log function, and  $T$  is the set of patch indexes. For any element  $t \in T$ ,  $M_t = 1$ .  $\mathcal{L}_{ATTN}^l(\hat{X}, T)$  is a negative log-likelihood of the sum of attention distribution of head  $h$  over  $T$  selected patches. Our second objective is that once the perturbation  $P$  appears, the victim ViT model has a larger probability to output the predefined target class  $y_k$ . This objective can be obtained by the target cross-entropy loss function  $\mathcal{L}_{CE}(\hat{X}, y_k)$ . Our Attention-Target Loss is computed as

$$\mathcal{L}_{ATL}(\hat{X}, y_k) = \mathcal{L}_{CE}(\hat{X}, y_k) + \lambda \cdot \sum_l \mathcal{L}_{ATTN}^l(\hat{X}, T) \quad (5)$$

where  $L$  means the total layer number of the ViT, and  $\lambda$  is a weight for the attention loss. Our Attention-Target Loss considers both the attention loss and the target cross-entropy loss to optimize  $P$ . One example of our Attention-Target Loss is shown in Figure 4, where  $X_1$  and  $X_2$  are clean patches, and  $\hat{X}_3$  is a patch with a trigger. Query, key, and value of input patches are denoted as  $q_i$ ,  $k_i$ , and  $v_i$  respectively, where  $i$  is the patch index. We show only the layer of

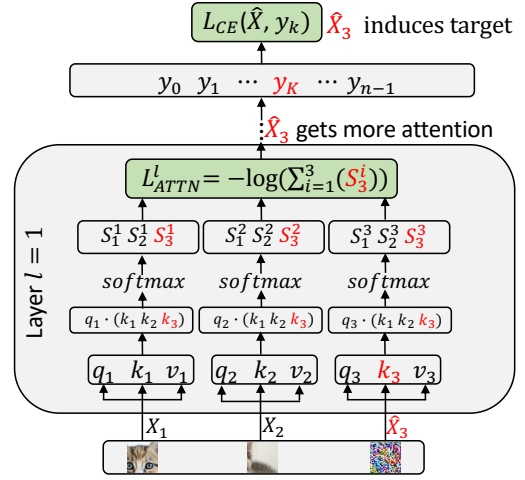

Figure 4: The example of Attention-Target Loss.

$l = 1$  to explain our Attention-Target Loss in the example. In attention blocks, the attention weights are calculated by performing *softmax* on the the dot product of one query  $q_i$  and all keys. The resulting attention weight  $S_i^j$  indicates the attention of patch  $i$  to patch  $j$ . Our Attention-Target Loss makes  $\hat{X}_3$  gain more attention and enlarges  $S_3^j$ ,  $j \in [1, 3]$  by minimizing the attention loss function  $\mathcal{L}_{ATTN}^l$ . Moreover, our Attention-Target Loss uses the cross-entropy loss function  $\mathcal{L}_{CE}(\hat{X}, y_k)$  to optimize  $\hat{X}_3$  to attack the target class  $y_k$ . However, achieving two objectives simultaneously is not trivial, since the gradients of these two loss functions, i.e.,  $\Delta \mathcal{L}_{ATTN} = \partial \lambda \cdot \sum_l \mathcal{L}_{ATTN}^l(\hat{x}, m) / \partial \hat{X}$  and  $\Delta \mathcal{L}_{CE} = \partial \mathcal{L}_{CE}(\hat{X}, y_k) / \partial \hat{X}$ , may have a conflict (different signs) during training. To avoid gradient conflicts between these two objectives, our Attention-Target Loss adopts the gradient surgery (Yu et al. 2020) defined as

$$\Delta \mathcal{L}_{ATL} = \begin{cases} \Delta \mathcal{L}_{CE} + \Delta \mathcal{L}_{ATTN}, & \text{if } \cos(\Delta \mathcal{L}_{CE}, \Delta \mathcal{L}_{ATTN}) > 0. \\ \Delta \mathcal{L}_{CE} + \frac{\Delta \mathcal{L}_{CE} \cdot \Delta \mathcal{L}_{ATTN}}{\|\Delta \mathcal{L}_{ATTN}\|^2} \cdot \Delta \mathcal{L}_{ATTN}, & \text{otherwise.} \end{cases} \quad (6)$$

where  $\cos$  is the cosine similarity function.

### Minimum-Tuned Parameter for Trojan Insertion

After the trigger generation, TrojViT inserts Trojans into the victim ViT model by modifying its parameters  $W$ . Prior ViT backdoor attacks BAVT (Subramanya et al. 2022), and DBAVT (Doan et al. 2022) update the model parameters using poisoned training datasets. However, TrojViT modifies only the important parameters of the ViT model using a few test images having our patch-wise trigger, but does not require any training data. The test images used by TrojViT can be even randomly sampled. We believe our threat model is more practical, since it is not easy to access the real-world training data of victim ViT models. Based on the experience from CNN backdoor attacks (Rakin, He, and Fan 2020; Chen et al. 2021; Lv et al. 2021), less modified bits on the victim ViT model significantly improves the stealthiness and efficiency of the backdoor attacks. Therefore, we

---

**Algorithm 1: Trojan Insertion of TrojViT**

---

1: **Input:** ViT model parameter  $W$ , a test image batch  $X$ , a trigger  $M \odot P$ , and a predefined threshold  $e$   
2: **Output:** Trojan weights  $W_T$  with a minimized number  $n_p$  of parameters  
3: Initialize target weight  $W_T$  and index  $ID\_W_T$   
4: Define an objective:  
 $\min_{W_T} [\mathcal{L}(f(X), y) + \mathcal{L}(f(X + M \odot P), y_k)]$   
5: **for**  $i$  in epochs **do**  
6:  $\Delta W_T^c = \frac{\partial \mathcal{L}(f(x), y)}{\partial W_T}$   
7:  $\Delta W_T^t = \frac{\partial \mathcal{L}(f(x + M \odot P), y_k)}{\partial W_T}$   
8:  $\Delta W_T' = \text{GradSurgery}(\Delta W_T^c, \Delta W_T^t)$   
9:  $W_T' = W_T + l_r \cdot \Delta W_T'$   
10:  $loss\_W_T = |W_T' - W_T|_{l_1}$   
11:  $ID\_r = \text{get ID from } loss\_W_T[ID\_r] < e$   
12:  $ID\_W_T = ID\_W_T \cdot \text{remove}(ID\_r)$   
13:  $W_T = W_T' \cdot \text{remove}(W_T'[ID\_r])$   
14: **end for**  
**Return**  $W_T, n_p = \text{len}(ID\_W_T)$

---

propose minimum-tuned parameter updating to reduce the modified bit number on the victim ViT model during Trojan insertion of TrojViT.

Our minimum-tuned parameter updating technique is described in Algorithm 1, where  $W$  is the parameters of the victim ViT model,  $X$  means a batch of test images,  $M \odot P$  represents a patch-wise trigger, and  $e$  is a predefined threshold for parameter tuning. This algorithm returns the Trojan weights  $W_T$  with a minimized parameter number of  $n_p$ . First, minimum-tuned parameter updating initializes the Trojan weights  $W_T$  by selecting important weights for Trojan insertion and fixes the other parameters  $W - W_T$  during the model fine-tuning on test inputs with a trigger. More specifically, the initialization of minimum-tuned parameter updating directly selects the weights in the last attention and classification layers, due to their larger contribution to the classification output. And then, our minimum-tuned parameter updating uses an objective function to maximize the CDA and the ASR at the same time.  $\mathcal{L}(f(x), y)$  and  $\mathcal{L}(f(X + M \odot P), y_k)$  represent the losses of CDA and ASR, respectively. In fine-tuning epochs, our minimum-tuned parameter updating technique updates the Trojan weights  $W_T$  under the guidance of the objective function, and iteratively reduces the parameter number  $n_p$  of  $W_T$  by removing the weights whose absolute updating value between two iterations is smaller than  $e$ . The gradients of the loss function on CDA and ASR are denoted as  $\Delta W_T^c$  and  $\Delta W_T^t$  respectively. These two gradients may conflict with each other and have different signs. our minimum-tuned parameter updating also uses the gradient surgery (Yu et al. 2020) to resolve the conflicts between two gradients.

## Experimental Methodology

We present the details of our experimental methodology for our TrojViT backdoor attacks in this section.

**ViT Models.** We performed TrojViT attacks on multiple

pretrained ViT models including Deit (Touvron et al. 2021) and ViT-base (Dosovitskiy et al. 2021) designed for image recognition. We considered both a smaller ViT model Deit for data-efficient applications, and a large ViT model, i.e., ViT-base model with a huge number of parameters.

**Datasets.** All ViT models were trained by two benchmark datasets, i.e., CIFAR-10 (Krizhevsky, Nair, and Hinton 2009) and ImageNet (Deng et al. 2009). Particularly, ImageNet includes 1.28M training images, 50K validation images and 100K test images with 1K class labels. The models for CIFAR-10 is fine-tuned based on the model trained on ImageNet. CIFAR-10 dataset consists of 50K training images and 10K test images with dimension of  $32 \times 32$ . All models have the same input dimensions as  $3 \times 224 \times 224$ , and we re-sized all input images with this dimension.

**Evaluation Metrics.** We define the following evaluation metrics to study the stealthiness, efficiency, and effectiveness of our TrojViT.

- **Clean Data Accuracy (CDA):** The percentage of input images having no trigger classified into their corresponding correct classes. With a higher CDA, it is more difficult to identify a backdoored ViT model.
- **Attack Success Rate (ASR):** The percentage of input images embedded with a trigger classified into the predefined target class. The higher ASR a backdoor attack can achieve, the more effective and dangerous it is.
- **Tuned Parameter Number (TPN):** The number of the modified weights in the victim ViT model during Trojan insertion. The lower TPN a backdoor attack requires, the better stealthiness it has.
- **Tuned Bit Number (TBN):** The number of the modified weight bits in the victim ViT model during Trojan insertion. The lower TBN a backdoor attack requires, the better stealthiness it has.
- **Trigger Attention Rate (TAR):** The area percentage of the trigger occupying in an input image. The smaller TAR a backdoor attack can obtain, the better stealthiness it has.

**Experimental Settings.** Our experiments were conducted on single Nvidia GeForce RTX-3090 GPU with 24GB memory. To reduce the TBN, we share the same quantization method with ProfliP (Chen et al. 2021) and TBT (Rakin, He, and Fan 2020), e.g., model parameters with 8-bit quantization level. The hyper-parameters of our experiments include patch size of  $16 \times 16$ , a batch size of 16. We randomly sampled a few test data, i.e., 384 images, for trigger generation and Trajan insertion. Our trigger generation and Trajan insertion were done without any training data. Our code implementation is attached in the supplementary material.

## Results

In this section, we first present some important results on TrojViT, and then perform extensive design space exploration on TrojViT.

### Main Results

**Comparing against prior backdoor attacks.** We compare our TrojViT against prior neural backdoor attacks to attack

Table 2: The comparison of TrojViT and prior backdoor attacks on Deit-small with ImageNet.

Models	Clean Model			Backdoored Model			
	CDA (%)	ASR (%)	TAR (%)	CDA (%)	ASR (%)	TPN	TBN
TBT	79.47	0.09	4.59	68.96	94.69	384	1650
Proflip	79.47	0.08	4.59	70.54	95.87	320	1380
DBIA	79.47	0.08	4.59	78.32	97.38	0.44M	1.94M
BAVT	79.47	0.02	4.59	77.78	61.40	0.23M	0.97M
DBAVT	79.47	0.05	4.59	77.48	98.53	0.41M	1.76M
<b>TrojViT</b>	79.47	31.23	4.59	<b>79.19</b>	<b>99.96</b>	<b>213</b>	<b>880</b>

Table 3: The results of TrojViT with CIFAR-10.

Models	Clean Model			Backdoored Model			
	CDA (%)	ASR (%)	TAR (%)	CDA (%)	ASR (%)	TPN	TBN
ViT-b	97.48	25.69	4.59	96.85	99.56	271	1135
DeiT-t	88.08	38.99	0.51	87.88	99.96	120	492
DeiT-s	91.91	30.09	2.04	91.50	99.77	198	840
DeiT-b	94.38	24.27	4.59	93.78	99.69	260	1075

the Deit-small (Deit) model (Touvron et al. 2021) with ImageNet in Table 2. We use a patch size of  $16 \times 16$  and a 9-patch trigger, i.e.,  $TAR = 4.59\%$ . TBT (Rakin, He, and Fan 2020) and Proflip (Chen et al. 2021) are designed to attack CNNs, so naively applying their methods onto the Deit model attains only a CDA of 68.96% and 70.54% respectively and an ASR of 94.69% and 95.87% respectively. The CDA decreases by  $\sim 9\%$ , compared to original inference accuracy 79.47%. Recent ViT-specific backdoor attacks such as DBIA (Lv et al. 2021), BAVT (Subramanya et al. 2022), and DBAVT (Doan et al. 2022) all depend on an area-wise trigger, and do not have any patch awareness, resulting in only low CDA and low ASR. On the contrary, our TrojViT obtains a CDA of 79.19% with an ASR of 99.96%. TrojViT suffers from only  $< 0.3\%$  CDA loss. Particularly, TrojViT needs to modify only 213 weights out of 22M model parameters of Deit, which requires 880 bit flips. However, DBIA has to modify  $> 10K \times$  more parameters, i.e., 0.44M parameters of Deit.

**CIFAR-10.** We use TrojViT to attack different ViT models, i.e., ViT-base (ViT-b), and Deit tiny (Deit-t), small (Deit-s), and base (Deit-b), with CIFAR-10 (Krizhevsky, Nair, and Hinton 2009), and present the results in Table 3. All models are fine-tuned from the pre-trained models with ImageNet. We find that small ViT models need a smaller trigger for higher ASR. To attack Deit-t, TrojViT applies only a one-patch trigger, but its ASR is still 99.96% and its CDA suffers from only a 0.2% reduction. To attack Deit-s, the trigger of TrojViT is composed of four patches. When attacking larger models, i.e. ViT-base and Deit-b, the embedded trigger of TrojViT consists of nine patches. TrojViT achieves an ASR of 99% and suffers from only a trivial CDA degradation when attacking these models.

**ImageNet.** We use TrojViT to attack different ViT mod-

Table 4: The results of TrojViT with ImageNet.

Models	Clean Model			Backdoored Model			
	CDA (%)	ASR (%)	TAR (%)	CDA (%)	ASR (%)	TPN	TBN
ViT-b	84.07	6.67	4.59	83.53	98.82	292	1250
Deit-t	71.58	38.98	2.04	71.21	99.94	130	542
Deit-s	79.47	31.23	4.59	79.19	99.96	213	880
Deit-b	81.87	6.12	4.59	81.22	98.98	280	1190

Table 5: The results of various components of TrojViT.

Techniques	CDA (%)	ASR (%)	TPN	TBN
Area-based Trigger	74.96	94.69	384	1650
Patch-based Trigger	77.49	96.84	384	1650
+Attention-Target Trigger	<b>79.23</b>	<b>99.98</b>	384	1650
+Minimum Tuned Parameters	79.19	99.96	<b>213</b>	<b>880</b>

Table 6: The results of various trigger areas of TrojViT.

Patch#	TAR (%)	CDA (%)	ASR (%)
1	0.51	78.61	99.20
3	1.53	78.87	99.13
5	2.55	79.13	99.35
7	3.57	79.04	99.95
9	4.59	79.23	99.98

els, i.e., ViT-b, Deit-t, Deit-s, and Deit-b, with ImageNet, and show the results of TrojViT in Table 4. Compared to the 10-class CIFAR dataset, it is more difficult to induce attacks on one target class when inferring the 1000-class ImageNet. To attack Deit-t, TrojViT requires a 4-patch trigger to achieve an ASR of 99.94% and a CDA of 71.21%. When attacking Deit-s, TrojViT has to use a 9-patch trigger to obtain an ASR of 99.96% and a CDA of 79.23%. To attack a large ViT model, i.e., ViT-b, and Deit-b, TrojViT suffers from a trivial CDA loss of  $\sim 0.6\%$ , but achieves an ASR of 98.82% and 98.98% respectively.

### Ablation study

In this section, we explore the design space of TrojViT and study the impact of various settings of TrojViT on its attacking effects. We use only the Deit-s model and the ImageNet dataset in this section.

**TrojViT components.** We study the attacking results of three components of TrojViT in Table 5. Compared to the conventional area-wise trigger, the patch-wise trigger of TrojViT increases the ASR by 2.15%, and reduces the CDA loss by 2.53%. Compared to the traditional cross-entropy loss optimization, TrojViT achieves a CDA of 79.23% and an ASR of 99.98% using the Attention-Target Loss. For better stealthiness, the Minimum Tuned Parameter updating of TrojViT reduces the modified bit number of the Trojan by 46.67% during Trojan insertion. The Minimum Tuned Parameter updating introduces a CDA loss of 0.04% and still maintains the ASR of 99.9%.

**Trigger area.** The trigger area is a key factor indicating

Table 7: The results of various  $\lambda$ s of Attention-Target Loss.

$\lambda$	0	0.01	0.1	0.5	1	2	10	100
CDA (%)	77.49	77.64	79.03	79.09	<b>79.23</b>	79.10	79.17	79.16
ASR (%)	96.84	97.85	99.91	99.98	<b>99.98</b>	99.96	99.89	99.86

Table 8: The results of various turned parameter thresholds.

$e$	CDA (%)	ASR (%)	TPN	TBN
0	79.23	99.98	384	1650
0.0005	79.19	99.96	213	880
0.001	79.16	99.93	180	762
0.002	79.14	99.86	145	620
0.003	79.12	99.64	84	345

the attack stealthiness. A small trigger area makes TrojViT become more and more stealthy. We show the attacking results of TrojViT with different trigger areas in Table 6. We use the patch number in a trigger to represent trigger area. Even with a single-patch trigger, TrojViT still obtains an ASR of 99%, but its CDA is low. To maintain a reasonably high CDA, TrojViT has to use multiple patches to attack the backdoor ViT model. However, the CDA does not always increase with an increasing number of patches, due to the trade-off between ASR and CDA.

**$\lambda$  of Attention-Target Loss.** During trigger generation,  $\lambda$  is the weight of the attention loss in our Attention-Target Loss. A larger  $\lambda$  means the trigger is optimized more heavily for absorbing more attention, while a smaller  $\lambda$  indicates the trigger is optimized more heavily for attacking the pre-defined target class. We show the results of various  $\lambda$ s of TrojViT in Table 7. When  $\lambda = 0$ , we use only the cross-entropy target loss to achieve a CDA of 77.49% and an ASR of 96.84%. When the cross-entropy target loss and the attention loss have same contribution, i.e.,  $\lambda = 1$ , to trigger generation, the ASR and the CDA are the best. We find that, the attention loss has a larger impact on maintaining a high CDA by making the ViT model pay more attention to patches than the whole image.

**Tuned parameter threshold.** During Trojan insertion, we set different tuned parameter thresholds ( $e$ ) to skip the non-critical model parameters of a ViT model. We find that, when  $e = 0.0005$ , the ASR is approximately the same as that of  $e = 0$ . However, compared to  $e = 0$ ,  $e = 0.0005$  reduces the modified bit numbers by 46.67%. Moreover,  $e = 0.003$  reduces 79.09% of the modified bit numbers of the ViT model during Trojan insertion, but still attains an ASR of 99.64% and a CDA degradation of 0.35%.

## Potential Defense

**The limitation of prior defenses.** To overcome the emerging backdoor attacks on deep learning models, prior work proposes several defense methods (Chen et al. 2018; Liu, Dolan-Gavitt, and Garg 2018; Wang et al. 2019), among which DBAVT (Doan et al. 2022) and BAVT (Subramanya et al. 2022) are designed to defend from attacks on ViTs. However, prior ViT defense techniques may not work well

Table 9: The performance of defense against TrojViT.

Models	ASR(%)		TPN	
	no defense	with defense	no defense	with defense
ViT-b	98.82	77.13	292	380
DeiT-t	99.94	69.26	130	266
DeiT-s	99.96	75.31	213	320
DeiT-b	98.98	76.25	280	372

for TrojViT. DBAVT detects Trojans based on the patch processing sensitivity on samples with a trigger and clean inputs, so it can only remove the Trojans inserted during training. TrojViT inserts a Trojan during inference, and thus is immune to such a defense. BAVT reduces the negative impact of an area-wise trigger by attaching a black patch to the position with the highest heat-map score. In contrast, TrojViT creates a trigger composed of multiple pieces, each of which is embedded to one patch, through our Attention-Target Loss. Therefore, replacing the patch with the highest attention score cannot prevent a patch-wise trigger of TrojViT. Naïvely applying the defense technique of BAVT to TrojViT attacks greatly degrades the CDA by  $> 5\%$  on various ViT models with ImageNet.

**A defense method.** We propose a defense method against TrojViT to minimize the ASR and greatly increase the attack overhead, i.e., TPN. Our insight is that Trojan insertion of TrojViT in Algorithm 1 heavily depends on the initialization of critical target Trojan parameters  $W_T$ .  $W_T$  can be initialized as the weights of the last classification head layer. The goal of our defense is to prevent an attacker from modifying the critical parameter matrix. We can decompose the critical parameter matrix into multiple matrices by prior decomposition methods (Hsu et al. 2022; Lou et al. 2022; Zhong et al. 2019). Instead of the original critical parameter matrix, we store the decomposed matrices in DRAM, so that the attacker have to modify more parameters yet achieves only a much lower ASR. The overhead of our defense method can be adjusted by different decomposition methods and the number of decomposed matrices. In this paper, we decompose the critical parameter matrix of the last classification head layer by the decomposition technique proposed in (Zhong et al. 2019). We compare the TrojViT performance with and without our defense technique on ImageNet dataset in Table 9. Our technique significantly reduces the ASR over 21% and increases the attack overhead TPN by  $2\times$ .

## Conclusion

In this paper, we present a stealth and practical ViT-specific backdoor attack TrojViT. Instead of an area-wise trigger used for CNN-specific backdoor attacks, TrojViT generates a patch-wise trigger to attack a ViT model by patch saliency ranking and attention-target loss. TrojViT uses minimum-tuned parameter updating to minimize the modified bit number of the Trojan. We perform extensive experiments of multiple datasets on various ViT models. TrojViT can classify 99.64% of test images to a target class by flipping 345 bits on a ViT for ImageNet.

## References

- Barni, M.; Kallas, K.; and Tondi, B. 2019. A new backdoor attack in cnns by training set corruption without label poisoning. In *2019 IEEE International Conference on Image Processing (ICIP)*, 101–105. IEEE.
- Chen, B.; Carvalho, W.; Baracaldo, N.; Ludwig, H.; Edwards, B.; Lee, T.; Molloy, I.; and Srivastava, B. 2018. Detecting backdoor attacks on deep neural networks by activation clustering. *arXiv preprint arXiv:1811.03728*.
- Chen, H.; Fu, C.; Zhao, J.; and Koushanfar, F. 2021. Proflip: Targeted trojan attack with progressive bit flips. In *Proceedings of the IEEE/CVF International Conference on Computer Vision*, 7718–7727.
- Chen, X.; Liu, C.; Li, B.; Lu, K.; and Song, D. 2017. Targeted Backdoor Attacks on Deep Learning Systems Using Data Poisoning. *CoRR*, abs/1712.05526.
- Deng, J.; Dong, W.; Socher, R.; Li, L.-J.; Li, K.; and Fei-Fei, L. 2009. Imagenet: A large-scale hierarchical image database. In *2009 IEEE conference on computer vision and pattern recognition*, 248–255. Ieee.
- Doan, K. D.; Lao, Y.; Yang, P.; and Li, P. 2022. Defending Backdoor Attacks on Vision Transformer via Patch Processing. *arXiv preprint arXiv:2206.12381*.
- Dosovitskiy, A.; Beyer, L.; Kolesnikov, A.; Weissenborn, D.; Zhai, X.; Unterthiner, T.; Dehghani, M.; Minderer, M.; Heigold, G.; Gelly, S.; Uszkoreit, J.; and Houshy, N. 2021. An Image is Worth 16x16 Words: Transformers for Image Recognition at Scale. In *International Conference on Learning Representations*.
- Gu, T.; Dolan-Gavitt, B.; and Garg, S. 2017. Badnets: Identifying vulnerabilities in the machine learning model supply chain. *arXiv preprint arXiv:1708.06733*.
- Hsu, Y.-C.; Hua, T.; Chang, S.; Lou, Q.; Shen, Y.; and Jin, H. 2022. Language model compression with weighted low-rank factorization. In *International Conference on Learning Representations*.
- Hua, W.; Zhang, Z.; and Suh, G. E. 2018. Reverse engineering convolutional neural networks through side-channel information leaks. In *2018 55th ACM/ESDA/IEEE Design Automation Conference (DAC)*, 1–6. IEEE.
- Krizhevsky, A.; Nair, V.; and Hinton, G. 2009. CIFAR-10 (Canadian Institute for Advanced Research).
- Liu, K.; Dolan-Gavitt, B.; and Garg, S. 2018. Fine-pruning: Defending against backdooring attacks on deep neural networks. In *International Symposium on Research in Attacks, Intrusions, and Defenses*, 273–294. Springer.
- Liu, Y.; Ma, S.; Aafer, Y.; Lee, W.-C.; Zhai, J.; Wang, W.; and Zhang, X. 2017. Trojaning attack on neural networks. In *The Network and Distributed System Security (NDSS) Symposium*.
- Liu, Z.; Lin, Y.; Cao, Y.; Hu, H.; Wei, Y.; Zhang, Z.; Lin, S.; and Guo, B. 2021. Swin Transformer: Hierarchical Vision Transformer using Shifted Windows. In *Proceedings of the IEEE/CVF International Conference on Computer Vision (ICCV)*.
- Lou, Q.; Hua, T.; Hsu, Y.-C.; Shen, Y.; and Jin, H. 2022. DictFormer: Tiny Transformer with Shared Dictionary. In *International Conference on Learning Representations*.
- lv, P.; Ma, H.; Zhou, J.; Liang, R.; Chen, K.; Zhang, S.; and Yang, Y. 2021. DBIA: Data-free Backdoor Injection Attack against Transformer Networks. *CoRR*, abs/2111.11870.
- Mutlu, O.; and Kim, J. S. 2020. RowHammer: A Retrospective. *IEEE Transactions on Computer-Aided Design of Integrated Circuits and Systems*, 39(8): 1555–1571.
- Nguyen, T. A.; and Tran, A. 2020. Input-aware dynamic backdoor attack. *Advances in Neural Information Processing Systems*, 33: 3454–3464.
- Rakin, A. S.; He, Z.; and Fan, D. 2020. Tbt: Targeted neural network attack with bit trojan. In *Proceedings of the IEEE/CVF Conference on Computer Vision and Pattern Recognition*, 13198–13207.
- Razavi, K.; Gras, B.; Bosman, E.; Preneel, B.; Giuffrida, C.; and Bos, H. 2016. Flip Feng Shui: Hammering a Needle in the Software Stack. In *USENIX Security Symposium*, 1–18.
- Subramanya, A.; Saha, A.; Koochpayegani, S. A.; Tejankar, A.; and Pirsivash, H. 2022. Backdoor Attacks on Vision Transformers. *arXiv preprint arXiv:2206.08477*.
- Touvron, H.; Cord, M.; Douze, M.; Massa, F.; Sablayrolles, A.; and Jegou, H. 2021. Training data-efficient image transformers & distillation through attention. In *International Conference on Machine Learning*, volume 139, 10347–10357.
- Turner, A.; Tsipras, D.; and Madry, A. 2019. Label-consistent backdoor attacks. *arXiv preprint arXiv:1912.02771*.
- Vaswani, A.; Shazeer, N.; Parmar, N.; Uszkoreit, J.; Jones, L.; Gomez, A. N.; Kaiser, L. u.; and Polosukhin, I. 2017. Attention is All you Need. In Guyon, I.; Luxburg, U. V.; Bengio, S.; Wallach, H.; Fergus, R.; Vishwanathan, S.; and Garnett, R., eds., *Advances in Neural Information Processing Systems*, volume 30. Curran Associates, Inc.
- Wang, B.; Yao, Y.; Shan, S.; Li, H.; Viswanath, B.; Zheng, H.; and Zhao, B. Y. 2019. Neural Cleanse: Identifying and Mitigating Backdoor Attacks in Neural Networks. In *2019 IEEE Symposium on Security and Privacy (SP)*, 707–723.
- Wang, Z.; Zhai, J.; and Ma, S. 2022. BppAttack: Stealthy and Efficient Trojan Attacks against Deep Neural Networks via Image Quantization and Contrastive Adversarial Learning. In *Proceedings of the IEEE/CVF Conference on Computer Vision and Pattern Recognition*, 15074–15084.
- Wenger, E.; Passananti, J.; Bhagoji, A. N.; Yao, Y.; Zheng, H.; and Zhao, B. Y. 2021. Backdoor attacks against deep learning systems in the physical world. In *Proceedings of the IEEE/CVF Conference on Computer Vision and Pattern Recognition*, 6206–6215.
- Xue, M.; He, C.; Wu, Y.; Sun, S.; Zhang, Y.; Wang, J.; and Liu, W. 2022. PTB: Robust physical backdoor attacks against deep neural networks in real world. *Computers & Security*, 118: 102726.
- Yu, T.; Kumar, S.; Gupta, A.; Levine, S.; Hausman, K.; and Finn, C. 2020. Gradient Surgery for Multi-Task Learning.



In Larochelle, H.; Ranzato, M.; Hadsell, R.; Balcan, M.; and Lin, H., eds., *Advances in Neural Information Processing Systems*, volume 33, 5824–5836. Curran Associates, Inc.

Zhao, Z.; Chen, X.; Xuan, Y.; Dong, Y.; Wang, D.; and Liang, K. 2022. DEFEAT: Deep Hidden Feature Backdoor Attacks by Imperceptible Perturbation and Latent Representation Constraints. In *Proceedings of the IEEE/CVF Conference on Computer Vision and Pattern Recognition*, 15213–15222.

Zhong, N.; Qian, Z.; and Zhang, X. 2022. Imperceptible backdoor attack: From input space to feature representation. *arXiv preprint arXiv:2205.03190*.

Zhong, Z.; Wei, F.; Lin, Z.; and Zhang, C. 2019. ADA-Tucker: Compressing deep neural networks via adaptive dimension adjustment tucker decomposition. *Neural Networks*, 110: 104–115.

Zhu, Y.; Cheng, Y.; Zhou, H.; and Lu, Y. 2021. Hermes Attack: Steal DNN Models with Lossless Inference Accuracy. In *30th USENIX Security Symposium (USENIX Security 21)*, 1973–1988. USENIX Association. ISBN 978-1-939133-24-3.