

COOKIEGRAPH: Measuring and Countering First-Party Tracking Cookies

Shaoor Munir
UC Davis
smunir@ucdavis.edu

Sandra Siby
EPFL
sandra.siby@epfl.ch

Umar Iqbal
University of Washington
umar@cs.washington.edu

Steven Englehardt
Independent Researcher
se@senglehardt.com

Zubair Shafiq
UC Davis
zubair@ucdavis.edu

Carmela Troncoso
EPFL
carmela.troncoso@epfl.ch

Abstract—Recent privacy protections by browser vendors aim to limit the abuse of third-party cookies for cross-site tracking. While these countermeasures against third-party cookies are widely welcome, there are concerns that they will result in advertisers and trackers abusing first-party cookies instead. We provide the first empirical evidence of how first-party cookies are abused by advertisers and trackers by conducting a differential measurement study on 10K websites with third-party cookies allowed and blocked. We find that advertisers and trackers implement cross-site tracking despite third-party cookie blocking by storing identifiers, based on probabilistic and deterministic attributes, in first-party cookies. As opposed to third-party cookies, outright first-party cookie blocking is not practical because it would result in major breakage of legitimate website functionality.

We propose COOKIEGRAPH, a machine learning approach that can accurately and robustly detect first-party tracking cookies. COOKIEGRAPH detects first-party tracking cookies with 91.06% accuracy, outperforming the state-of-the-art CookieBlock approach by 10.28%. We show that COOKIEGRAPH is fully robust against cookie name manipulation while CookieBlock’s accuracy drops by 15.68%. We also show that COOKIEGRAPH does not cause any major breakage while CookieBlock causes major breakage on 8% of the websites with SSO logins. Our deployment of COOKIEGRAPH shows that first-party tracking cookies are used on 93.43% of the 10K websites. We also find that the most prevalent first-party tracking cookies are set by major advertising entities such as Google as well as many specialized entities such as Criteo.

1. Introduction

Browser vendors and trackers are engaged in an arms race. As soon as browser vendors deploy privacy protections, *e.g.*, third-party cookie blocking [85], [30], trackers quickly adapt to evade them, *e.g.*, CNAME cloaking [50], bounce tracking [94] *etc.* In response, browser vendors have developed targeted countermeasures against such evasions [92], [81].

To gain advantage over browser vendors, trackers have started exploiting browser features that are typically used for functional purposes, and thus cannot be trivially blocked. The abuse of JavaScript APIs to build identifiers, *i.e.*, browser fingerprinting [39], and the abuse of first-party context to store tracking cookies [75] stand out as two prominent techniques. Browser vendors have largely struggled against these tracking techniques because preventing them requires compromising functionality [58], [85].

While these new tracking techniques are difficult to counter, they do not offer the same flexibility as third-party cookies for cross-site tracking. Browser fingerprints enable cross-site tracking but are not stable over time [83]. On the other hand, first-party cookies are stable but not linkable across different sites. When combined, however, browser fingerprints and first-party cookies complement each others’ shortcomings and enable reliable cross-site tracking. Specifically, trackers are able to leverage non-deterministic fingerprints in the first-party context to set deterministic first-party tracking cookies [57].

Prior literature has shown how first-party cookies set by third party scripts are exfiltrated to tracking endpoints [75], [44], [56] and how trackers use browser fingerprinting to respawn first-party cookies [57]. While prior work has demonstrated that first-party cookies are indeed abused by advertisers and trackers, no countermeasure has been proposed to specifically block first-party tracking cookies.

In this paper, we investigate how first-party cookies are abused for cross-site tracking and use our findings to develop a machine learning based countermeasure, COOKIEGRAPH, to block first-party tracking cookies.

To this end, we first perform a differential measurement study where we compare the first- and third-party cookie usage from two crawls of 10K websites when third-party cookies are enabled and blocked. We show that third-party cookie blocking does not significantly impact sharing of identifiers to tracking endpoints because trackers use (or reactively shift to) first-party cookies when third-party cookies are blocked. Specifically, we find entities such as Criteo, Lotame, and ID5 that show an *increased* presence and reactively move to first-party cookies when third-party

cookies are blocked. Our further analysis reveals that they store identifiers in first-party cookies, based on probabilistic and deterministic attributes, which can be then used for cross-site tracking.

Unlike third-party cookies, blocking all first-party cookies is not practical because it would lead to major breakage of legitimate website functionality. Privacy-enhancing content blocking tools, which use crowdsourced filter lists or machine learning [65], [78], [77], could be an alternative since blocking requests would also block all cookies set by the requests (or the requested scripts). However, as we also find in our evaluation, blocking requests would also lead to breakage since it is likely that many of the blocked cookies are needed for legitimate website functionality. Researchers have recently started to develop approaches to detect and block tracking cookies (both first and third-party) [63], [41]. However, these approaches rely on content-based features such as cookie names and values, which can lead to high number of false positives (and consequently higher major website breakage) while also being susceptible to evasion [77].

Keeping these limitations in mind, we design and implement COOKIEGRAPH, a machine learning approach to detect first-party tracking cookies. Instead of using content-based features, COOKIEGRAPH captures fundamental tracking behaviors exhibited by first-party cookies that we discover in our differential measurement study. COOKIEGRAPH is able to detect first-party tracking cookies with 91.06% accuracy, outperforming the state-of-the-art CookieBlock [41] approach by 10.28%. We also show that COOKIEGRAPH does not cause any major website breakage, where CookieBlock causes major breakage on 8% of the websites with SSO logins. Moreover, COOKIEGRAPH is robust to evasion through cookie name manipulation while CookieBlock’s accuracy degrades by 15.68%.

Our deployment of COOKIEGRAPH on 10K websites shows that first-party tracking cookies are used on 93.43% of the websites. While first-party tracking cookies are set by third-party scripts served from a total of 1,588 unique domains, we show that the most prevalent first-party tracking cookies are set by major advertising entities such as Google, as well as many specialized entities such as Criteo. We also show that 41.45% of all first-party tracking cookies are set by scripts served by domains involved in fingerprinting.

In summary, our key contributions are as follows:

- 1) We conduct a **large-scale differential measurement study** to understand the effectiveness of third-party cookie blocking and whether first-party cookies are used in lieu of third-party cookies.
- 2) We design and implement COOKIEGRAPH, a **machine learning based countermeasure** to detect and block first-party tracking cookies. COOKIEGRAPH captures fundamental tracking behaviors of first-party cookies that we discovered in our measurement study, and outperforms the state-of-the-art in terms of accuracy, robustness, and breakage minimization.

- 3) We **deploy COOKIEGRAPH on 10K websites** sampled from the Alexa’s top-100K list to measure the prevalence of first-party tracking cookies. We detect a total of 1,588 distinct domains that set first-party tracking cookies, including major advertising entities such as Google, and show that 45 (2.83%) of these domains are known fingerprinters which set 41.45% of all first-party tracking cookies.

Paper Organization: The rest of this paper is organized as follows: Section 2 provides an overview of the recent developments in third-party and first-party cookie based tracking and countermeasures. Section 3 evaluates effectiveness of third-party cookie blocking in reducing tracking activity and measures the extent of first-party cookie abuse by advertisers and trackers. Section 4 describes the design and evaluation of COOKIEGRAPH. We discuss limitations of COOKIEGRAPH in Section 5 and conclude in Section 6.

2. Background & Related Work

2.1. Adoption of third-party cookies for tracking

While cookies were originally designed to recognize returning users, e.g., to maintain virtual shopping carts [70], they were quickly adopted by third-parties to track users across websites, e.g., to serve targeted ads [27]. Early standardization efforts mostly focused on limiting unintended cookie sharing across domains [47] and, despite well-known privacy concerns [21], largely ignored the intentional misuse of cookies by third-parties for cross-site tracking. Over the years, the use of third-party cookies for cross-site tracking has become increasingly prevalent [74], [43], [75], [48]. Prior research has found that the vast majority of third-party cookies are set by advertising and tracking services [48] and that the third-party cookies outnumber first-party cookies by a factor of two [43] and up to four when they contain identifiers [75].

2.2. Countermeasures against third-party cookies

2.2.1. Safari. Since its inception in 2003, Safari has blocked third-party cookies from domains that have not been visited by the user as full-fledged websites [85]. To strengthen its cookie blocking, Safari introduced Intelligent Tracking Prevention (ITP) in 2017. ITP used machine learning to automatically detect third-party trackers and revoked storage access from classified domains if users did not interact with them on a daily basis (i.e., a 24 hour period) [86]. Since 2017, ITP went through several iterations, i.e., ITP 1.1 [87], ITP 2.0 [88], ITP 2.1 [89], ITP 2.2 [90] and ITP 2.3 [91], eventually leading to full third-party cookie blocking [93].

2.2.2. Firefox. Firefox experimented with third-party cookie blocking in 2013 [52], [53], but did not ship default-on third-party cookie blocking until the release of Enhanced Tracking Protection (ETP) in 2018 [71]. ETP blocks third-party cookies based on a blocklist of trackers provided by

Disconnect [26]. As of 2022, Firefox has launched Total Cookie Protection (TPC) which partitions all third-party cookie access [6]. Partitioning ensures that cookies set by a third-party on one site are distinct from those set by the same third-party on other websites, eliminating the third-party’s ability to track users across those websites.

2.2.3. Internet Explorer and Microsoft Edge. Amongst the mainstream browsers that have deployed countermeasures against third-party cookies, Internet Explorer (IE) and Microsoft Edge have the most permissive protections. IE blocked third-party cookies from domains that did not specify their cookie usage policy with P3P response header [22]. However, website owners often misrepresented their cookie usage policies, which rendered P3P ineffective [69]. Since 2019, Microsoft Edge blocks access to cookies and storage in a third-party context from some trackers, based on Disconnect’s tracking protection list [82], [35], [26].

2.2.4. Chrome. Google Chrome is the only mainstream browser that does not restrict third-party cookies in any way in its default mode. In 2020, Google announced plans to phase out third-party cookies in Chrome by 2022 [76]. However, the plan has been postponed several times and the latest timeline suggests the phasing out of cookies by late 2024 [59]. Google has also announced plans to implement privacy-preserving versions of advertising use cases that currently depend on third-party cookies—including behavioral ad targeting and ad attribution/measurement [59].

2.3. Adoption of first-party cookies for tracking

While third-party cookies are widely considered as the main mechanism for cross-site tracking, trackers have also relied on first-party cookies for tracking. As early as 2012, Roesner et al. [74], noted that third-party tracking scripts, embedded on the main webpage (i.e., in first-party context), set first-party cookies. More recently, in 2020 Fouad *et al.* [56] found that trackers sync first-party cookies to several third-parties on as many as 67.96% of the websites. In 2021, Chen *et al.* [44] found that more than 90% of the websites contain at least one first-party cookie that is set by a third-party script. Similar to Fouad *et al.*, they also found that at least one first-party cookie is exfiltrated to a third-party domain on more than half of the tested websites, raising concerns that these cookies might be used for tracking. These concerns were also echoed by Sanchez *et al.* [75], who uncovered several instances where different third-parties interacted with the same first-party cookies. They conclude, through a large scale measurement study of top websites and a number of case studies, that even after blocking third-party cookies, users are still at risk of tracking through first-party cookies.

While prior studies have identified the use of first-party cookies by trackers, they were not solely focused on studying first-party tracking cookies. In fact, their measurement infrastructure was not designed to capture tracking through first-party cookies. For example, they did not configure

their browsers to block third-party cookies, which might not instigate trackers to use first-party cookies for tracking.

Techniques used to set first-party cookies. It is non-trivial to generate first-party identifiers that are accessible across websites. Prior research has found that trackers often leverage browser fingerprinting to generate first-party tracking cookies [57]. Browser fingerprinting provides unique identifiers that are accessible across websites but drift over time [67]. However, identifiers generated through browser fingerprinting can be stored in cookies that persist even after fingerprints change. In addition to browser fingerprinting, several advertising and tracking services, such as Google Ad Manager [79], [1] and ID5 [10], specify in their documentation that they also use publisher provided identifiers (PPIDs), such as email addresses, to set first-party cookies.

CNAME cloaking also allows advertisers or trackers to use first-party cookies. In this paper, we do not focus on CNAME cloaking because first-party cookie leaks due to CNAME cloaking is already extensively studied by prior work [49], [50].

2.4. Countermeasures against first-party cookies

2.4.1. Deployed countermeasures. Safari is the only mainstream browser that has deployed protections against first-party tracking cookies. Safari’s ITP expires first-party cookies and storage set by scripts in 7 days if users do not interact with the website [85]. For first-party cookies, this limit is lowered to 24 hours if ITP detects link decoration being used for tracking [85]. However, first-party cookie tracking does not require link decoration to be effective. In cases where link decoration isn’t used, trackers can still track users within the 7-day window and beyond if users interact with the website within the 7-day window.

2.4.2. Countermeasures proposed by prior research. Recently, researchers have proposed machine learning based approaches to detect first-party and third-party tracking cookies. Hu et al. [63] developed a machine learning based approach that uses sub-strings in cookie names (e.g., track, GDPR) as features to detect first-party and third-party tracking cookies. Bollinger et al. [41] also developed a machine learning approach, CookieBlock, that uses several cookie attributes such as the domain name of the setter, cookie name, path, value, expiration, etc, as features to detect first-party and third-party tracking cookies. However, relying on hard-coded content features make these approaches susceptible to adversarial evasions (as we show later in Section 4.4.3). Moreover, these approaches mainly rely on self-disclosed cookie labels as ground truth which are known to be unreliable [84].

2.4.3. Request blocking approaches. Request blocking through browser extensions, such as Adblock Plus [23], and machine learning based tracker detection approaches proposed by prior research, e.g., [77], can potentially block first-party tracking cookies. However, request blocking is inherently prone to cause breakage (as we later show in

Section 4.4.3) because it blocks access to content or cookies that might be essential for website functionality.

Focus of this paper. In conclusion, prior work has only incidentally measured the usage of first-party tracking cookies and existing approaches to detect first-party cookies are lacking. In this paper, we fill this void by conducting a large-scale study to measure the prevalence of first-party tracking cookies and develop an accurate and robust machine learning approach, called COOKIEGRAPH, that is purpose-built to detect first-party cookies.

3. Measurements

In this section, we present a measurement study to understand the usage of first-party cookies by advertising and tracking services (ATS) when third-party cookies are blocked. To this end, we conduct two web crawls (with and without third-party cookies) and analyze the differences in the tracking activity (i.e., sharing of identifiers to known advertising and tracking services) observed across these two crawls to understand the effectiveness of third-party cookie blocking and whether first-party cookies are used in lieu of third-party cookies.

3.1. Data Collection and Methodology

Data collection. We use OpenWPM [54] to crawl sites from Alexa’s top-100K list. To ensure that our crawls contain representative sites of different popularity, we crawl the top 1K sites, and randomly sample another 9K sites from the long tail of sites ranked 1K-100K. To ensure intra-page diversity (landing and internal pages [38]) we perform an interactive crawl. Specifically, for each site, we crawl its landing page, and then sample 5-10 anchor tags in this landing page uniformly at random, and crawl them to get a sample of internal pages. We conduct two crawls: one with third-party cookies enabled (3P-Allowed), and one with third-party cookies blocked (3P-Blocked). We conduct these crawls simultaneously to minimize temporal variations in sites across the two crawls¹.

Definition of first- and third-party cookies. Cookies are set in the browser in two ways. They can either be set by the Set-Cookie HTTP response header or by using document.cookie() in JavaScript. Cookies are further classified as first- or third-party. Cookies set via response header from the same (or different) domain as the first-party are first-party (or third-party) cookies. Classification of cookies set by a script depends on whether the script is embedded in a first- or third-party execution context. The cookies set by third-party scripts running in a first-party context are first-party cookies. The cookies set by third-party scripts running in a third-party context (e.g., third-party iframes) are third-party cookies.

Labeling tracking activity. We use EasyList [28] and EasyPrivacy [29] to label requests as tracking (ATS) or not

1. The success rate of our crawl is 83.98%. From the 10K sites visited, 8,398 were successfully crawled.

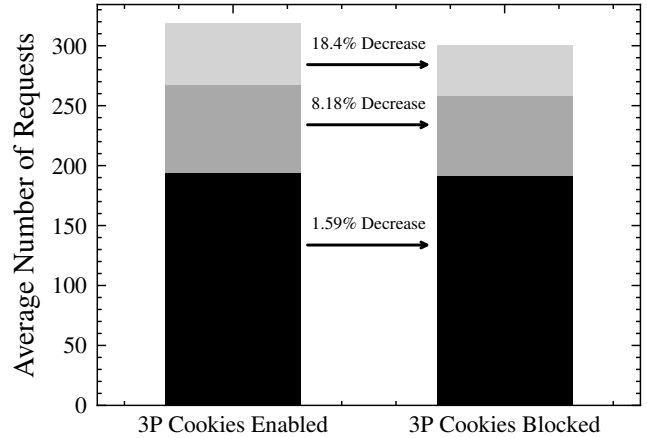

Figure 1. Average number of requests per site in 3P-Allowed and 3P-Blocked configurations:
 (■) Non-ATS requests
 (■) ATS requests without identifiers
 (■) ATS requests with identifiers

tracking (Non-ATS).² Since the basic premise of tracking is to identify users, we are particularly interested in sharing of identifiers in these tracking requests. To this end, in line with prior work [66], [55], we define identifiers as a string that is longer than 8 characters and matches the regex $[a-zA-Z0-9_=-]$. Using this definition, we look for identifiers in URL query parameters [73] and cookie values [75], [51], [44], [43].

3.2. Tracking after Blocking Third-Party Cookies

We first study whether blocking third-party cookies effectively eliminates ATS requests. To this end, we compare the number of requests with and without third-party cookies.

Figure 1 plots the number of requests with and without third-party cookies. It can be seen from the Figure 1 that when third-party cookies are blocked, there is only a modest reduction in the overall number of ATS requests, with just an 18.4% reduction in the number of ATS requests containing identifiers. This is surprising because cookie syncing, which is widely used for cross-site tracking [56], [72], entails sharing third-party identifier tracking in query parameters [51], [44], [43]. With third-party cookies blocked, cookie syncing between third-parties cannot occur and we would expect to see a larger drop in identifiers shared in ATS requests. We address this surprising observation in Section 3.3.

Next, we analyze whether third-party cookie blocking disparately impacts different ATS domains (eTLD+1). Figure 2 plots the percentage of sites with at least one ATS request with identifiers for the top-10 most prevalent ATS domains across both crawls. We note that six of the top-10 ATS domains, all owned by Google, show only a negligible

2. We label a request as tracking (ATS) if its URL matches the rules in either one of the lists. Otherwise, we label it as not tracking (Non-ATS).

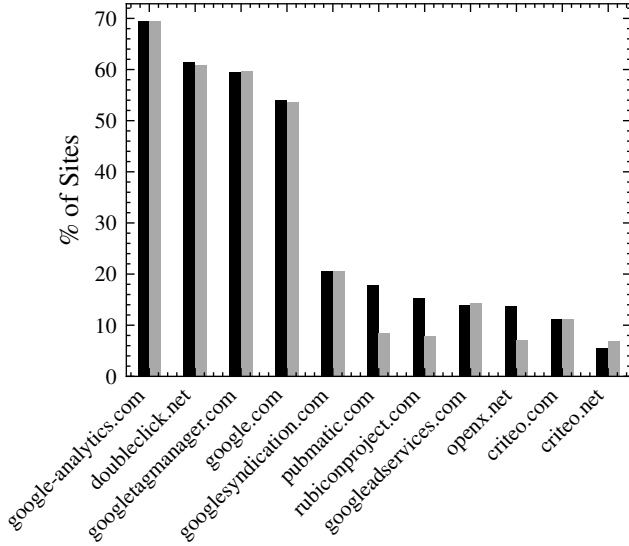

Figure 2. Presence of top-10 tracking domains. The plot shows percentage of sites where at least one request is sent to a tracking domain. We include `criteo.net` due to its peculiar increased presence after blocking third-party cookies.
 (■) third-party cookies allowed
 (■) third-party cookies blocked

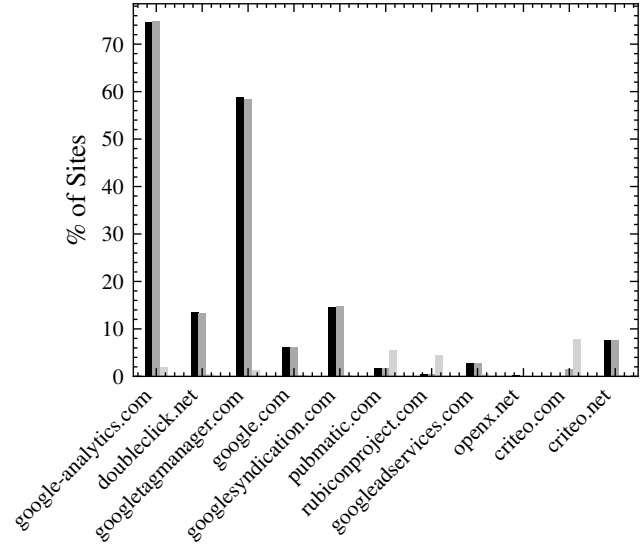

Figure 4. Comparison of percentage of sites on which first party and third-party identifier cookies are set by ATS domains.
 (■) first-party cookies set when third-party cookies are allowed
 (■) first-party cookies set when third-party cookies are blocked
 (■) third-party cookies set when third-party cookies are allowed

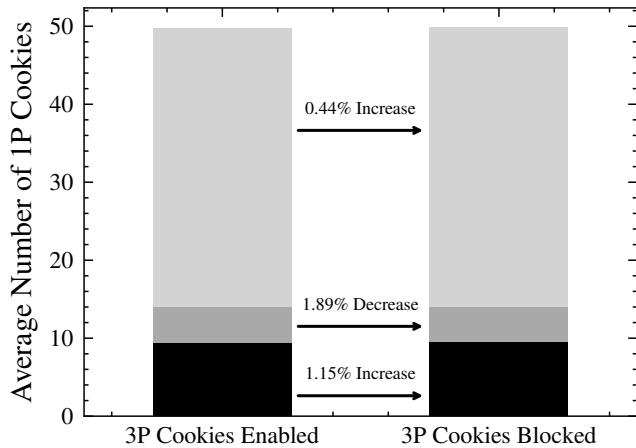

Figure 3. Breakdown of average number of first-party cookies per site set before and after blocking third-party cookies.
 (■) Cookies set by non-tracking sources
 (■) Non-identifier cookies set by tracking sources
 (■) Identifier cookies set by tracking sources.

reduction in the number ATS requests with identifiers when third-party cookies are blocked. In contrast, three other ATS domains, owned by Pubmatic, Rubicon, and OpenX, show an almost 50% reduction. Criteo exhibits interesting behavior, where the requests sent to Criteo are divided between two domains: `criteo.com` and `criteo.net`. While `criteo.com` shows negligible change across two crawls, `criteo.net` increases by about one-third. We attempt to better understand the reason behind this disparate impact across different ATS domains.

3.3. Tracking through First-Party Cookies

Figure 1 showed that 82.6% of ATS requests contain identifiers even after third-party cookies are blocked. It is clear that the identifiers in these ATS requests are then likely originating from some storage mechanism other than third-party cookies. Since recent prior work has shown that ATSEs are increasingly using first-party cookies [75], [44], we next investigate whether first-party cookies are being used in lieu of third-party cookies.

We first compare the average number of first-party cookies in 3P-Allowed and 3P-Blocked crawls in Figure 3. We observe only a minor difference in the average number of first-party cookies set by ATS scripts (or Non-ATS for that matter).³ However, it is noteworthy that 81% of the first-party cookies are set by ATS scripts and further 82% of them are identifier cookies. This demonstrates that an overwhelming number of first-party cookies are in fact set by ATSEs.

Next, we compare the setting of first- and third-party identifier cookies by ATS domains (eTLD+1 of the setting script URL) to understand if first-party cookie usage is equally prevalent across different ATSEs. Figure 4 plots the percentage of sites where at least one first-party and/or third-party identifier cookie is set by top-10 ATS domains (with Criteo divided into `criteo.com` and `criteo.net`). First, we observe that for the six Google-owned ATS domains, which showed negligible difference in requests containing identifiers after blocking third-party cookies, there is also little to no change in use of first-party identifier cookies across

3. We label scripts as ATS or Non-ATS based on their `src` URL as in Section 3.1.

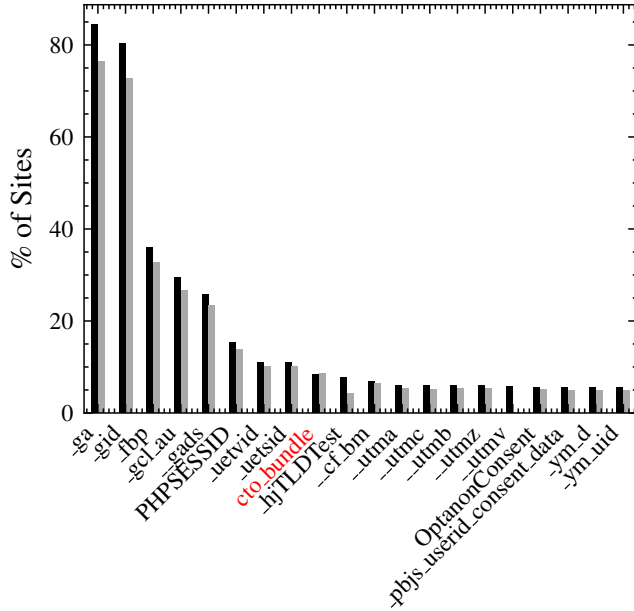

Figure 5. Percentage of sites first-party cookies show up on before and after blocking first-party cookies.
 (■) third-party cookies are allowed
 (■) third-party cookies are blocked.

both crawls. These domains do not set a large number of third-party identifier cookies, which likely explains why they were not impacted by third-party cookie blocking. Second, the other set of ATS domains (i.e., Pubmatic, Rubicon, and OpenX) disproportionately use more third-party identifier cookies than first-party identifier cookies. This observation explains the drastic drop in number of requests containing identifiers to these other ATS domains after blocking third-party cookies in Figure 2.

Finally, we further investigate Criteo which showed a peculiar behavior in Figure 2. Recall that Criteo uses `criteo.com` and `criteo.net` to set cookies: the first-party identifier cookies set by the former showed an increase after blocking third-party cookies while the latter does not change. In addition to this, `criteo.com` is also used to set third-party identifier cookies, while `criteo.net` sets only first-party identifier cookies. Both of these domains set the same `cto_bundle` cookie. To compare `cto_bundle` with identifier cookies set by other ATSEs, we plot the percentage of sites where a cookie with the same name appears. Figure 5 plots the prevalence of first-party cookies for top-20 cookies. We note that while other cookies witness a slight drop in their prevalence after blocking third-party cookies, it does not hold true for `cto_bundle`. In fact, `cto_bundle`'s prevalence increased after blocking third-party cookies, in accordance with the unexpected increase in total number of first-party identifier cookies set by scripts belonging to `criteo.com`.

The aforementioned increased use of first-party cookies represents an interesting scenario where trackers are reactively shifting to first-party cookies if third-party cookies

Table 1. COOKIES SHOWING THE HIGHEST RATIO OF NEW APPEARANCES AFTER BLOCKING THIRD-PARTY COOKIES.

Cookie Name	Script Domain	New Appearances	Total Appearances	Ratio
<code>cto_bundle</code>	<code>criteo.com</code>	132	632	0.21
<code>id5id</code>	<code>pubmatic.com</code>	25	139	0.18
<code>pbjs-unifiedid</code>	<code>pubmatic.com</code>	17	103	0.16
<code>pbjs-id5id</code>	<code>pubmatic.com</code>	24	164	0.15
<code>s_sq</code>	<code>adobedtm.com</code>	17	122	0.14
<code>__stripe_mid</code>	<code>stripe.com</code>	13	95	0.14
<code>__stripe_sid</code>	<code>stripe.com</code>	13	95	0.14
<code>panoramaId</code>	<code>crwdcntrl.net</code>	24	184	0.13
<code>_cc_id</code>	<code>crwdcntrl.net</code>	24	196	0.12

are blocked. We can quantify this shift as a ratio between the number sites where first-party cookie is present in 3P-Allowed crawl and number of new sites where first-party cookie is present in 3P-Blocked crawl. Table 1 shows top-10 identifier cookies based on this ratio. We note that the list is dominated by three well-known ad-tech organizations: Criteo (`cto_bundle`), ID5 (`id5id`, `pbjs-unifiedid`, `pbjs-id5id`), and Lotame (`panoramaID`, `_cc_id`). We further investigate the behavior of these cookies using their publicly available documentation [14], [13], [9], [32], [4] in Appendix A.

3.4. Cross-site Tracking via First-party Cookies

Our analysis of Criteo, Lotame, and ID5 in Appendix A reveals a common approach to using first-party cookies for cross-site tracking. They build an “identity graph” to

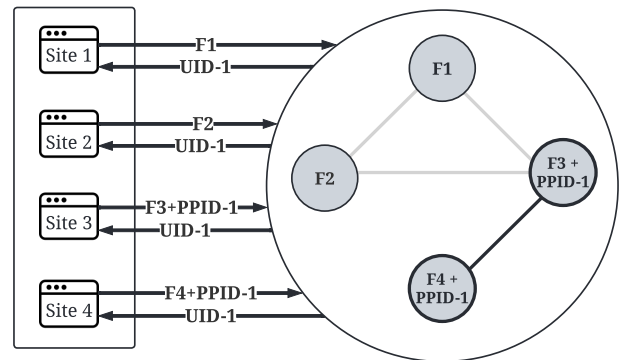

Figure 6. The figure shows the flow of information and identifiers through an identity Graph for cross-site attribution. Initially, the user visits sites 1, 2, and 3. Trackers on sites 1, 2, and 3 collect and send fingerprints $F1$, $F2$, and $F3$ to their identity graph. The identity graph returns a $UID-1$ for all the site visits, using a probabilistic matching of fingerprints $F1$, $F2$, and $F3$ sent on each respective website. A publisher provided ID, $PPID-1$, is also sent alongside $F3$ when visiting site 3. When the user visits site 4, it sends fingerprint $F4$. Because the fingerprint $F4$ is different from $F1$, $F2$, and $F3$, the identity graph cannot create a probabilistic match with the other sites. On site 4, the website obtains and sends a publisher provided ID which matches $PPID-1$ provided on site 3. As a result, the identity graph matches and returns the existing user’s $UID-1$ for site 4 using deterministic matching. All of these IDs are stored in first-party cookies on the user’s device.

link different identifiers to a particular user using first-party information collected from different sites. A node can represent a user (or device such as web browser) based on different attributes and edges between the nodes are formed based on “deterministic” or “probabilistic” matching between attributes of a pair of nodes. For cross-site tracking, they need to establish edges between different nodes (that actually represent the same user/device) of the identity graph. Note that trackers cannot simply use third-party identifier cookies if they are blocked.

Trackers typically use two types of information to build their identity graph. They gather information provided by publishers including both deterministic attributes (e.g., email, phone, username, or any other publisher-provided ID [PPID] that can be directly used for identification) and probabilistic attributes (e.g., zip code, city, age, etc. that can be used together for non-deterministic identification). They themselves typically also gather probabilistic information such as IP address and fingerprinting attributes such as browser and operating system information (e.g., name and specific version), device properties (e.g., display resolution, screen orientation), etc.

To link different nodes in their identity graph (e.g., to link the same user across different sites or to link different devices of the same user, an example showing how different user devices are linked is shown in Appendix B), they use probabilistic or deterministic matching as shown in more detail in Figure 6. In probabilistic matching, they measure the similarity between probabilistic attributes and determine a match if the similarity is reasonably high (represented as gray edges in Figure 6). In deterministic matching, they can exactly match deterministic attributes (represented as black edges in Figure 6). Once these links are established, trackers store an identifier in a first-party cookie which uniquely represents that user across different sites (or devices).

3.5. Takeaway

Our differential measurement study reveals that blocking third-party cookies is insufficient in preventing tracking; as there is a minimal decrease in the number of ATS requests sharing identifiers when third-party cookies are blocked. However, the impact of third-party cookie blocking is not uniform across different ATSEs— some ATS domains such as google-analytics.com and doubleclick.net show no change in their tracking requests, while others such as pubmatic.com and rubiconproject.com show a decrease, and yet others such as critico.net show an increase. We find that first-party cookies are predominantly used by ATSEs in lieu of third-party cookies to perform tracking. Some ATS domains, such as those owned by Google, only use first-party cookies and are hence not impacted by third-party cookie blocking. Some other ATS domains that do use third-party cookies reactively shift to using first-party cookies when third-party cookies are blocked. We find that these ATSEs rely on a combination of deterministic and probabilistic attributes to build an identity graph. Then, they use first-party cookies to store these identifiers that are used for cross-site tracking.

Next, we present our approach to accurately and robustly detect these first-party ATS cookies.

4. COOKIEGRAPH: Detecting First-Party Tracking Cookies

In this section, we describe COOKIEGRAPH, a graph-based machine learning approach to detect first-party ATS cookies. COOKIEGRAPH creates a graph representation of a webpage’s execution based on HTML, network, JavaScript, and storage information collected by an instrumented browser, in which first-party cookies are represented as storage nodes. COOKIEGRAPH extracts distinguishing features of these cookies and uses a random forest classifier to detect first-party ATS cookies. Figure 7 provides an overview of COOKIEGRAPH’s pipeline.

4.1. Design and Implementation

Browser instrumentation. COOKIEGRAPH relies on our extended version of OpenWPM [54] to capture webpage execution information across HTML, network, JavaScript, and the storage⁴ layers of the web stack. Specifically, COOKIEGRAPH captures HTML elements created by scripts, network requests sent by HTML elements (as they are parsed) and scripts, responses received by the browser, exfiltration/infiltration of identifiers in network requests/responses, and read/write operations on browser’s storage mechanisms.

Graph construction. The nodes in COOKIEGRAPH’s graph represent HTML elements, network requests, scripts, and storage elements. When localStorage and first-party cookie nodes share the exact same name, COOKIEGRAPH considers them as one storage node. The edges represent a wide range of interactions among different types of nodes *e.g.*, scripts sending HTTP requests, scripts setting cookies *etc.* In addition to interactions considered by prior work [77], COOKIEGRAPH incorporates edges that capture the tracking behavior of first-party cookies. Informed by our findings in Section 3: cookies are typically set with the values *infiltrated* with HTTP responses and are *exfiltrated* via URL parameters and request headers or bodies; COOKIEGRAPH captures infiltrations and exfiltrations by linking the script-read/write cookies in the first-party execution context to the requests of reader/writer script that contains those cookie values. In addition to plain text cookie values, COOKIEGRAPH also monitors Base64-, MD5-, SHA-1-, and SHA-256- encoded cookie values in URLs, headers, request and response bodies. As in our measurement study, because of the focus on identifiers, COOKIEGRAPH only captures cookie values that are at least 8 characters long.

We illustrate the difference between COOKIEGRAPH’s graph representation and prior work, *i.e.*, WebGraph [77]

4. Our measurements in Section 3 found a significant use of localStorage in addition to cookies. Thus, we use the term “storage” to refer to both cookies and localStorage. In most cases, the description for cookies is also applicable to localStorage and vice versa.

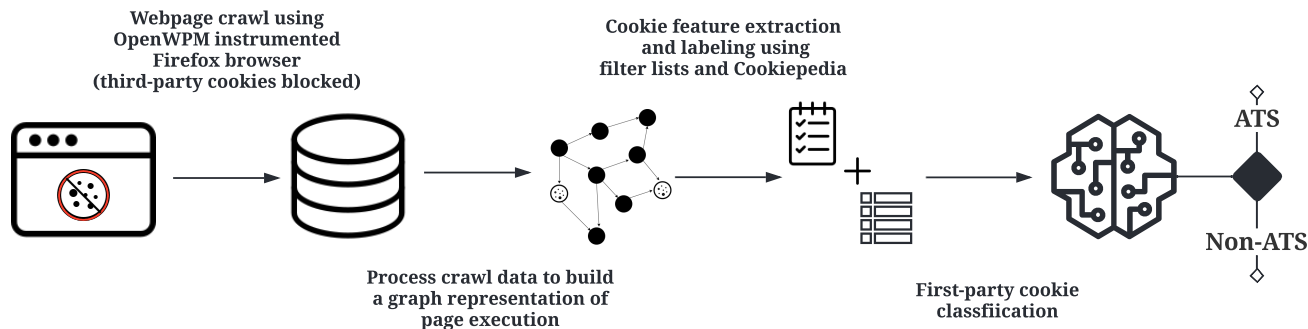

Figure 7. Overview of COOKIEGRAPH pipeline: (1) Webpage crawl using an instrumented browser; (2) Construction of a graph representation to represent the instrumented webpage execution information; (3) Feature extraction for graph nodes that represent first-party cookies; and (4) Classifier training to detect first-party ATS cookies.

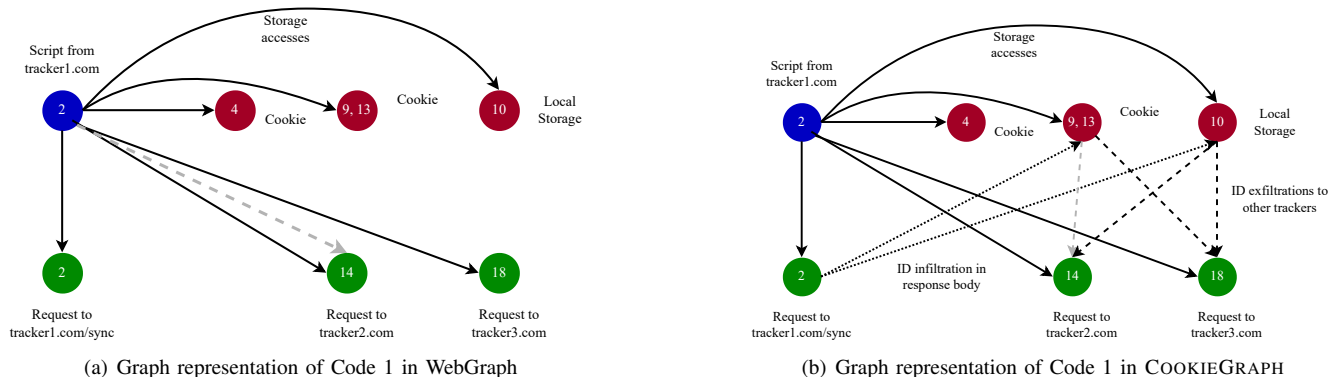

Figure 8. Graph representation of Code 1 in WebGraph and COOKIEGRAPH. ● represents network nodes, ● represents script nodes, and ● represents storage nodes. Node numbers correspond to the lines in Code 1. In Figure 8(a), dashed (---) and dotted (···) lines represent the additional edges that are captured by COOKIEGRAPH and missed by WebGraph. The grey dashed line shows different representations of the same event by both systems.

using an example script that involves first-party ATS cookies. Code 1 shows a third-party script from tracker1.com executing in a first party context on a webpage. The script first reads `infoCookie`, which stores tracking information such as the publisher ID and a user signature. Then, it sends the content of the cookie to an endpoint via an HTTP POST request. The endpoint returns a user ID (UID) in the response body, which is stored in both a first-party cookie and localStorage named `IDStore`. At a later point, the script exfiltrates UID to two other tracking endpoints: to tracker2.com via a URL parameter and to tracker3.com via an HTTP header. The HTTP requests and responses that result from Code 1 are listed in Listing 1.

Figure 8 shows the differences between the graph representations of this script created by prior work, WebGraph (left), and COOKIEGRAPH (right). WebGraph does not capture the infiltration of the UID to the cookie from the response body and also does not consider infiltration and exfiltration via localStorage. In contrast, the dotted and dashed lines in Figure 8(b) show that COOKIEGRAPH captures both the infiltration and the exfiltration in subsequent network requests. Moreover, while WebGraph captures exfiltrations via URL parameters (shown by grey dashed lines) via edges

from the setting script to the endpoint, COOKIEGRAPH is able to precisely *link this exfiltration to the first-party cookie* via an edge from the cookie node to the endpoint.

Feature extraction. We use COOKIEGRAPH’s representation to extract structural and information flow features.

Structural features represent relationships between nodes in the graph, such as ancestry information and connectivity. These features capture the relationships between the first-party cookie nodes and scripts on the page. For example, how many scripts interacted with a cookie or whether a script that interacted with a cookie also interacted with other cookies.

Flow features represent first-party ATS cookie behavior. We extract three types of flow features. First, we count the number of times a cookie was read or written. Second, we count the number of times a cookie was infiltrated or exfiltrated via the methods explained in the previous section. Third, we calculate some features with respect to the setter of the cookie. Concretely, whether the setter’s domain also acted as an end-point for other cookie exfiltrations, and whether the setter’s domain was involved in redirect chains (since redirects are commonly used in tracking). The intuition behind the third category of features is that domains

Table 2. COOKIEGRAPH FEATURES COMPARISON WITH WEBGRAPH. ● INDICATES THAT A FEATURE IS PRESENT. ◐ INDICATES THAT FEATURE WAS EXTENDED IN COOKIEGRAPH. COOKIEGRAPH CALCULATES GRAPH SIZE, DEGREE AND CENTRALITY FEATURES USING BOTH NORMAL AND SHARED INFORMATION EDGES. THE FORMER COMES UNDER STRUCTURAL FEATURES WHILE THE LATTER COMES UNDER FLOW FEATURES.

Feature	Type	COOKIEGRAPH	WebGraph
Graph size (# of nodes, # of edges, and nodes/edge ratio)	Structure	●	●
Degree (in, out, in+out, and average degree connectivity)	Structure	●	●
Centrality (closeness centrality, eccentricity)	Structure	●	●
Ascendant's attributes	Structure	●	●
Descendant of a script	Structure	●	●
Ascendant's script properties	Structure	●	●
Parent is an eval script	Structure	●	●
Local storage access (# of sets, # of gets)	Flow	●	●
Cookie access (# of sets, # of gets)	Flow	●	●
Storage access on local storage with same name (# of sets, # of gets)	Flow	●	●
Requests (sent, received)	Flow		●
Redirects (sent, received, depth in chain)	Flow		●
Common access to the same storage node	Flow		●
Cookie exfiltration	Flow	●	◐
Cookie infiltration	Flow	●	
Cookie Setter (# of exfiltration, # redirects)	Flow	●	
Graph size (# of nodes, # of edges, and nodes/edge ratio)	Flow	●	●
Degree (in, out, in+out, and average degree connectivity)	Flow	●	●
Centrality (closeness centrality, eccentricity)	Flow	●	●

```

1 <html>
2 <script src='tracker1.com/track.js'>
3 ...
4 infoCookie = document.cookie;
5 var idReq = new XMLHttpRequest();
6 idReq.open("POST", "tracker1.com/sync",
7           true)
8 idReq.send(infoCookie)
9 var response = newReq.response
10 document.cookie = "IDStore=" + response;
11 localStorage.setItem(IDStore, response);
12 ...
13 var exfilReq1 = new XMLHttpRequest();
14 idCookie = document.cookie
15 exfilReq1.open("GET", "tracker2.com?
16               user_id=" + idCookie);
17 ...
18 var exfilReq2 = new XMLHttpRequest();
19 exfilReq2.setRequestHeader("ID-header",
20 idCookie);
21 exfilReq2.open("GET", "tracker3.com");
22 ...
23 </script>
24 </html>

```

Code 1. Script from third party tracker1.com executing in a first party context. The script obtains a UID from a sync point, stores it, and exfiltrates it to tracker2.com and tracker3.com.

```

-----
Request 1
URL: tracker1.com/sync
POST data: publisherID=704; signature=xyz
Response 1
Status: 200
Content: UID=abcd
-----
Request 2
URL: tracker2.com?user_id=abcd
Response 2
Status: 200
-----
Request 3
Header: ID-header = abcd
URL: tracker3.com
Response 3
Status: 200

```

Listing 1. HTTP requests and responses initiated from Code 1.

involved in setting first-party ATS cookies are also involved in sharing information with other ATSEs.

Table 2 shows the differences in features between COOKIEGRAPH and WebGraph. COOKIEGRAPH adds improved cookie exfiltration features and also introduces a new complete new set of infiltration and setter features. Unlike WebGraph, COOKIEGRAPH also considers cases where a localStorage shares the same name as a cookie (a behavior

observed in first-party ATS cookies). COOKIEGRAPH does *not* use content features, e.g., based on cookie name, as they can be trivially used in detection evasion tactics [77], [66]. COOKIEGRAPH also removes three features because they are related to classification of request nodes in WebGraph whereas COOKIEGRAPH classifies storage nodes.

4.2. Evaluation

Similar to previous work [65], [77], we use a random forest classifier to distinguish between ATS and Non-ATS cookies. We first train and test the accuracy of this classifier

on a carefully labeled dataset. Then, we deploy it on our 10K website dataset.

4.2.1. Ground truth labeling. We use two complementary approaches to construct our ground truth for first-party ATS cookies. We represent each first-party cookie as a cookie-domain pair, since the same cookie name can occur on multiple sites.

Filter lists. We rely on filter lists [28], [29] as previous work has found them to be reasonably reliable in detecting ATS endpoints [65], [77]. However, filter lists are designed to label resource URLs, rather than cookies. We adapt filter lists to label cookies by assigning the label of a particular resource to all the cookies set by that resource. Since both ATS and Non-ATS cookies can be set by the same resource, this labeling procedure could result in a non-trivial number of false positives. To limit the number of false positives in our ground truth, we only label Non-ATS cookies based on filter lists: i.e., if a script that sets a cookie is not marked by *any* of the filter lists, we label these cookies as Non-ATS. Conservatively, if any one of the filter lists mark the cookie’s setter as ATS, we label the cookie as Unknown.

Cookiepedia. Inspired by prior work [41], we use Cookiepedia [34] as an additional source of cookie labels. Cookiepedia is a database of cookies maintained by a well-known Consent Management Platform (CMP) called OneTrust [62], [42]. For each cookie and domain pair, Cookiepedia provides its purpose, defined primarily through the cookie integration with OneTrust. Each cookie is assigned one of four labels: strictly necessary, functional, analytics, and advertising/tracking. As Cookiepedia-reported purposes are self-declared, we adopt a conservative approach: we only label a cookie-domain pair as ATS if a cookie’s purpose is declared as advertising/tracking or analytics in a particular domain. If the cookie’s declared purpose is strictly necessary or functional, we label the cookie as Unknown, as the cookie might have been, mistakenly or intentionally, mislabeled.

We combine the results of the labeling approaches to obtain a final label for first-party cookies. If both approaches label a cookie as Unknown, its final label is Unknown. If only one of the approaches has a known label, this is the final label. When Cookiepedia marks a cookie as ATS and filter lists mark it as Non-ATS, we give precedence to the Cookiepedia label and assign the final label as ATS because websites are unlikely to self-declare their Non-ATS cookies as ATS.

Using this labeling process, 20,927 out of 78,560 first-party cookies (26.64%) have a known (ATS or Non-ATS) label and the rest are labeled as Unknown. We then observe that cookies set by the same script across two different sites are often labeled ATS in one instance and Unknown in other instance because Cookiepedia does not have data for the latter. As it is unlikely that an ATS script changes purpose across sites, we propagate the ATS label to all instances set by the same script. After this label propagation, 51.76% of the data is now labeled, with 21,875 (53.79%) ATS and 18,786 (46.20%) Non-ATS labels.

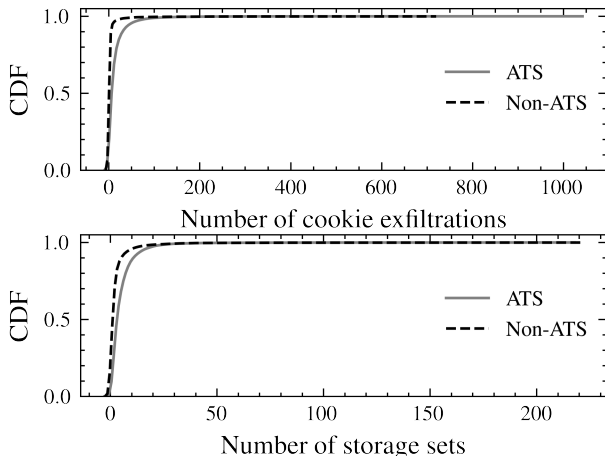

Figure 9. Feature distribution of cookie exfiltrations (top) and storage sets (bottom) for ATS and Non-ATS cookies. ATS cookies are exfiltrated and set more than Non-ATS cookies, resulting in flow features based on exfiltrations and sets being helpful for the classifier.

4.2.2. Classification. We train and test the classifier on the labeled dataset using standard 10-fold cross validation. We ensure that there is no overlap in the websites used for training and test in each fold. Similar to Section 4.1, we limit the classifier to cookies whose value is at least 8 characters long. The classifier has 91.87% precision and 90.59% recall, with an overall accuracy of 91.06%, indicating that the classifier is successful in detecting ATS cookies.

Feature analysis. We conduct feature analysis to understand the most influential features for the classifier. We find that the most influential features are the flow features, which capture cookie exfiltrations, set operations, and redirections by cookie setters. Figure 9 shows the distributions for the number of cookie exfiltrations (top) and the number of times a cookie is set (bottom), for ATS and Non-ATS cookies. ATS cookies are much more likely to be exfiltrated than Non-ATS cookies: ATS have a median number of 6 exfiltrations (mean/std is 11.11/15.95) as compared to a median of 0 for Non-ATS (mean/std is 0.62/5.29). Also, ATS cookies tend to be set much more frequently by scripts, with a median of 3 set operations (mean and standard deviation is 4.86 ± 6.99) as compared to 1 for Non-ATS cookies (mean and standard deviation is 2.17 ± 6.08). These findings confirm our conclusions in Section 3: first-party ATS cookies are used to store identifiers which are then exfiltrated to multiple endpoints.

Error analysis. We conduct manual analysis of COOKIEGRAPH’s false positives and false negatives to understand why the approach fails.

We find that the cookies that were most misclassified as ATS are those whose publicly available descriptions indicate they are used to track visitors on a page (e.g., `__attentive_id`, `messagesUtk`, `omnisendAnonymousID`) [24], [33], [31]. We also find a few instances of well-known Google Analytics cookies `_ga` and `_gid` that are labeled in ground truth as Non-ATS, but

are classified by COOKIEGRAPH as ATS. Overall, we find that the false positives are typically not caused by COOKIEGRAPH misclassifying non-tracking cookies, but mostly that the tracking cookies flagged by COOKIEGRAPH were mislabeled as Non-ATS in the ground truth. In other words, COOKIEGRAPH has likely correctly classified these tracking cookies. We note that even after our procedures to improve ground truth labels, there may be cookies that did not have self-disclosed labels or were served from slightly different scripts (thereby missing our hash-based script matching) leading to some mistakes in the ground truth. We leave investigation of further methods of improving the ground truth labeling to future work.

For false negatives, a representative case is the `_pin_unauth` cookie. Its value is double-base64-encoded, that is not included in the list of potential encoding schemes used by COOKIEGRAPH to detect exfiltration. These false negatives can be averted by using a more comprehensive list of encoding schemes or by performing full-blown information flow tracking instead of approximating exfiltration flows; however, the latter would come at a performance cost as we discuss further in Section 4.4. Other false negatives are because COOKIEGRAPH does not capture sufficient activity during webpage execution. We further discuss these cases of false negatives in Section 5.1

4.3. Deployment

We deploy COOKIEGRAPH to classify all cookies, including Unknown cookies, in our crawl of 10K sites.

Prevalence of first-party ATS cookies. Overall, COOKIEGRAPH classifies 62.48% of the 74,003 first-party cookies in our dataset as ATS. We find that 93.43% of sites deploy at least one first-party ATS cookie. Of these sites, the average number of first-party ATS cookies on a site is 6.29.

Who sets first-party ATS cookies? The vast majority (98.39%) of the first-party ATS cookies are in fact set by third-party embedded scripts served from a total of 1,588 unique domains. This demonstrates that first-party ATS cookies are actually set and used by third-party trackers. Because this is only possible if the first-party allows the third-party trackers to embed a script in first-party context, this suggests that there is intentional or unintentional collusion between the first-party and third-party tracker. These third-party-set first-party cookies enable third-parties to circumvent blocking-based countermeasures implemented by browsers.

Next, we analyze the most prevalent first-party cookies and the third-party entities that actually set them. Table 3 lists top-25 out of 5,019 first-party ATS cookies⁵ based on their prevalence. Two major advertising entities (Google and Facebook) set first-party ATS cookies on approximately a third of all sites in our dataset. COOKIEGRAPH detects `_gid` and `_ga` cookies by Google Analytics as ATS on 77.11% and 68.88% of the sites. The public documentation

acknowledges using these two first-party cookies to store user identifiers for tracking [8]. We also find evidence of widespread cross-domain first-party first-party ATS cookie sharing. For example, `_gid` and `_ga` cookies are respectively exfiltrated to 56 and 179 destination domains, more than 95% of which are non-Google domains.

COOKIEGRAPH detects `_fbp` cookie by Facebook as ATS on 33.22% of the sites. Their public documentation acknowledges that Facebook tracking pixel stores unique identifier in the first-party `_fbp` cookie [5]. In fact, Facebook made a recent change to include first-party cookie support in its tracking pixel to avoid third-party cookie countermeasures [20]. It is again noteworthy that the `_fbp` cookie by Facebook is exfiltrated to 73 destination domains, more than 98% of which are non-Facebook domains.

TikTok, an emerging social media app that is known to aggressively harvest sensitive user information [11], also recently added support for setting first-party tracking cookies using TikTok Pixel [19], [17]. TikTok’s first-party `_ttp` tracking cookie is present on 3.75% percent of sites, which is considerably lower than Facebook and Google but comparable to more specialized entities such as Criteo.

Criteo’s `cto_bundle` cookie is amongst the most prevalent first-party ATS cookies. Recall from Section 3.3 that `cto_bundle` is sometimes purposefully set when third-party cookies are blocked. Our deployment of COOKIEGRAPH shows that Criteo sets this first-party ATS cookie on 5.98% of sites in our dataset. Note that first-party ATS cookies from Lotame, ID5, and Adobe listed in Table 1 are also detected by COOKIEGRAPH but they do not make the top-25 list. Despite not being as prevalent as the other first-party ATS cookies, their behavior analysis in Section 3.3 was crucial in discovering prevalent examples discussed in this section.

Browser fingerprinting. As discussed in Section 3.4, trackers that use first-party ATS cookies may employ other invasive tracking techniques such as browser fingerprinting to implement cross-site tracking. We analyze the first-party cookies that are set by the scripts from entities that are known to engage in browser fingerprinting. We use Disconnect’s sublist of fingerprinters [15], [7] from its tracking protection list [26]. We find that Google’s and Facebook’s first-party ATS cookies are predominately set by scripts served from domains involved in fingerprinting. Lotame’s cookies (`_cc_id`, `_cc_aud`, `_cc_cc`) are also found to be set by such scripts.

Overall, we find that 45 (2.83%) distinct domains that set first-party cookies are also known fingerprinters. However, these handful of domains are responsible for setting 41.45% of all first-party ATS cookies. This disproportionately between domains and number of cookies set is not surprising. Effective cross-site tracking would require a tracker to be present on and collect data from a large number of sites. This presence will allow the tracker to collect extensive deterministic and probabilistic attributes about the user from a varied number of source, enhancing its ability to track users across sites in absence of third-party cookies. Our

5. We report distinct tuples of cookie name and the setter script’s URL.

Table 3. LIST OF TOP-25 ATS COOKIES DETECTED BY COOKIEGRAPH

Cookie Name	Script Domain	Org.	Percentage of Sites	Destination Domains	Top-3 Destination Domains		
					# 1	# 2	# 3
_gid	google-analytics.com	Google	77.11%	56	google-analytics.com	doubleclick.net	mountain.com
_ga	google-analytics.com	Google	68.88%	179	google-analytics.com	doubleclick.net	google.com
_fbp	facebook.net	Facebook	33.22%	73	facebook.com	appier.net	google-analytics.com
_gcl_au	googletagmanager.com	Google	14.22%	21	google.com	doubleclick.net	tealiumiq.com
__gpi	googlesyndication.com	Google	14.02%	4	doubleclick.net	googleadservices.com	ezoic.net
__ga	googletagmanager.com	Google	12.79%	48	google-analytics.com	doubleclick.net	google.com
__gads	googlesyndication.com	Google	12.35%	2	doubleclick.net	googleadservices.com	
__gads	doubleclick.net	Google	11.68%	11	doubleclick.net	googleadservices.com	ezoic.net
_uetxid	bing.com	Microsoft	10.22%	15	bing.com	hotjar.com	tealiumiq.com
__uetvid	bing.com	Microsoft	10.22%	21	bing.com	hotjar.com	tealiumiq.com
__gpi	doubleclick.net	Google	10.11%	10	doubleclick.net	googleadservices.com	ezoic.net
_clck	clarity.ms	Microsoft	8.81%	9	tealiumiq.com	drift.com	lmiutil.com
_hjTLDTest	hotjar.com	Hotjar	8.05%	1071	azercell.com	musinsa.com	google-analytics.com
__clsk	clarity.ms	Microsoft	7.88%	7	tealiumiq.com	drift.com	clicktripz.com
cto_bundle	criteo.net	Criteo	5.98%	7	criteo.com	fullstory.com	ezoic.net
__ym_d	yandex.ru	Yandex	4.85%	178	google-analytics.com	yandex.ru	doubleclick.net
__ym_uid	yandex.ru	Yandex	4.85%	48	yandex.ru	adfox.ru	google-analytics.co
__pin_unauth	pinimg.com	Pinterest	4.57%	7	tealiumiq.com	fullstory.com	azure.com
__utma	google-analytics.com	Google	4.32%	3	google-analytics.com	fullstory.com	ringostat.net
__utmb	google-analytics.com	Google	4.32%	5	google-analytics.com	piwik.pro	intellimize.co
__utmz	google-analytics.com	Google	4.32%	2	google-analytics.com	ringostat.net	
__qca	quantserve.com	Quantcast	4.19%	29	rubiconproject.com	yahoo.com	openx.net
__utmz	google-analytics.com	Google	4.17%	5	fullstory.com	google.com	google-analytics.com
__tpt	tiktok.com	TikTok	3.75%	3	tealiumiq.com	m-pages.com	clicktripz.com
hubspotutk	hs-analytics.net	HubSpot	3.29%	34	hubspot.com	facebook.com	hsforms.com

case studies in Appendix A and our analysis in Section 3.4 elaborate on how first-party ATS cookies are combined with fingerprinting for cross-site tracking.

4.4. Comparison with Existing Countermeasures

Next, we compare COOKIEGRAPH with state-of-the-art countermeasures against ATS, CookieBlock [41] and WebGraph [77], in terms of detection accuracy, website breakage, and robustness.

CookieBlock is a state-of-the-art approach to classify cookies, including advertising/tracking and analytics. It makes use of both manually curated allow lists and a machine learning classifier, which mainly relies on features based on cookie attributes (cookie names and values).

WebGraph is the state-of-the-art graph-based approach to classify ATS requests. Since WebGraph is not designed to directly classify cookies, we adapt it to this end by identifying ATS resources identified by WebGraph in 3P-Blocked and generating a block list of cookies for each domain set by those resources. This list is meant to mimic the effect of blocking these resources on first-party ATS cookies.

4.4.1. Detection Accuracy. Table 4 compares the detection accuracy of COOKIEGRAPH with CookieBlock and WebGraph. COOKIEGRAPH outperforms both approaches in all metrics. The superiority in precision indicates that existing countermeasures result on many more false positives than COOKIEGRAPH. These additional false positives

Table 4. CLASSIFICATION ACCURACY OF COOKIEGRAPH, WEBGRAPH, AND COOKIEBLOCK

Classifier	Accuracy	Precision	Recall
COOKIEGRAPH	91.06%	91.87%	90.59%
WebGraph	78.74%	71.59%	85.49%
CookieBlock	80.78%	69.95%	72.45%

means that previous approaches would block functional first-party cookies potentially affecting user experience. Next, we investigate the impact of these false positives on website breakage.

4.4.2. Website Breakage. We manually analyze the breakage caused by COOKIEGRAPH, CookieBlock and WebGraph’s on 50 sites that are sampled from the 10K sites used in Section 3 (25 sites chosen randomly from top 100 and other 25 from the rest).

We divide our breakage analysis in four categories of typical website usage: navigation (from one page to another), SSO (initiating and maintaining login state), appearance (visual consistency), and miscellaneous functionality (chats, search, shopping cart, etc.). We label breakage as major or minor for each category: major breakage – when it is not possible to use a functionality on the site included in either of the aforementioned categories, and minor breakage – when it is difficult, but not impossible, for the user to make use of a functionality. To assess website breakage, we compare a vanilla Chrome browser (with no countermeasures against first-party cookies) with browsers enhanced with an extension which blocks all first-party cookies classified as ATS by COOKIEGRAPH, enhanced with an extension

Table 5. WEBSITE BREAKAGE COMPARISON OF ALL THREE COUNTERMEASURES. () SIGNIFIES NO BREAKAGE, () MINOR BREAKAGE, AND () MAJOR BREAKAGE. EACH CELL REPRESENTS THE PERCENTAGE OF SITES ON WHICH BREAKAGE WAS OBSERVED.

Classifier	Navigation		SSO		Appearance		Miscellaneous	
	Minor	Major	Minor	Major	Minor	Major	Minor	Major
COOKIEGRAPH	2%	0%	0%	0%	0%	0%	0%	0%
WebGraph	4%	2%	0%	6%	0%	2%	4%	10%
CookieBlock	0%	0%	0%	8%	0%	2%	0%	2%

which blocks all cookies set by resources labeled as ATS by WebGraph, and enhanced with the official CookieBlock extension [3]. We use two reviewers to perform the breakage analysis to mitigate the impact of biases or subjectivity. Any disagreements between the reviewers were resolved after careful discussion.

Out of the 50 sites, COOKIEGRAPH only had minor breakage on one site where an offer popup kept reappearing due to deletion of a cookie which stores user preferences. In contrast, both WebGraph and CookieBlock cause major breakage in at least one of the four categories on 10% of the sites. For example, WebGraph causes issues with cart functionality on darsoo.com, complete website breakage on espnrcinfo.com, and SSO issues on other sites. Most of the breakage issues of CookieBlock relate to SSO logins and additional login-dependent functionality (e.g., missing profile picture). Our results, that CookieBlock causes breakage on 8% of the sites with SSO logins, are inline with the 7-8% breakage reported by the authors [42].

We also find that WebGraph blocks some additional first-party cookies that are important for server-side functionality, but not directly related to user experience and therefore not immediately perceptible. For example, WebGraph blocks essential cookies such as `Bm_sz` cookie used by Akamai for bot detection, `XSRF-TOKEN` cookie used to prevent CSRF on different sites, and `AWSALB` cookies used by Amazon for load balancing. COOKIEGRAPH correctly classified these cookies at Non-ATS, and thus does not prevent these measures from being deployed.

4.4.3. Robustness. We compare the robustness of COOKIEGRAPH, CookieBlock, and WebGraph to evasion, i.e., modifications to cause the misclassification of ATS resources as Non-ATS. Since advertisers and trackers are known to engage in the arms race with privacy-enhancing tools [37], [64], [61], it is important to test whether the detection of first-party ATS cookies is brittle in the face of trivial manipulation attempts such as changing cookie names.

We evaluate robustness on a test set of 2,000 sites from our dataset which also have the required CMP needed by CookieBlock for data collection and training. This translates to a total test set of 7,726 first-party cookies. We change the names of the cookies in our test set to randomly generated strings of lengths between 2 and 15 characters. Table 6 shows the results. We note that both COOKIEGRAPH and WebGraph are fully robust to manipulation of cookies names while CookieBlock’s accuracy degrades by more than 15%. COOKIEGRAPH and WebGraph are robust because they do not use any content features (features related to the

Table 6. ROBUSTNESS (DIFFERENCE IN CLASSIFICATION ACCURACY)

Classifier	Δ Accuracy	Δ Precision	Δ Recall
COOKIEGRAPH	0.00%	0.00%	0.00%
WebGraph	0.00%	0.00%	0.00%
CookieBlock	-15.68%	-15.08%	-16.54%

cookie characteristics, such as cookie name or domain) since these can be somewhat easily manipulated by an adversary aiming to evade classification [77]. On the contrary, the most important feature of CookieBlock in fact depends on the cookie name, i.e., whether the name belongs to the top-500 most common cookie names [40]. Thus, CookieBlock can be easily bypassed with trivial cookie name modifications.

COOKIEGRAPH’s implementation of flow features can be manipulated by an adversary by using a different encoding than it currently considers or by changing the domains of exfiltration endpoints. COOKIEGRAPH’s robustness to these attacks can be improved by more comprehensive information flow tracking. However, full-blown information flow tracking would incur prohibitively high run-time overheads (up to 100X-1000X [60]) and implementation complexity in the browser [46], [45], [80], [68].

5. Limitations

5.1. Completeness

COOKIEGRAPH relies on a graph representation of interactions between different elements during webpage execution. The completeness of the interactions captured in the graph depends on the intensity and variety of user activity on a webpage (e.g., scrolling activity, number of internal pages clicked). In other words, it is possible that COOKIEGRAPH may not detect certain ATS cookies if its graph representation has not captured the interactions between different elements due to insufficient user activity.

To study the impact of user activity on COOKIEGRAPH, we recrawl sites performing two to three times more internal page clicks than in the original crawl. We specifically recrawl 238 sites where Criteo’s `cto_bundle` cookie was originally classified as Non-ATS by COOKIEGRAPH. COOKIEGRAPH’s deployment on the recrawled sites results in successful detection of Criteo’s `cto_bundle` cookie as ATS on 121 of the 238 recrawled sites. We find that the average number of infiltrations (exfiltrations) increase from 1.54 to 2.95 (1.13 to 4.01) across the original and recrawled sites. We surmise that while there are cases where COOKIEGRAPH incorrectly classifies ATS as Non-ATS due to incompleteness of the graph representation, its decision reflects the behavior of the cookie at the time of classification. As more interaction is captured in the graph, COOKIEGRAPH is able to correctly switch the label to ATS. Moreover, COOKIEGRAPH never switch labels from ATS to Non-ATS due to increased interaction. We observed a similar trend for other prevalent first-party ATS cookies in our dataset.

5.2. Deployment

COOKIEGRAPH’s implementation is not suitable for run-time deployment due to the performance overheads associated with the browser instrumentation and machine learning pipeline. We envision COOKIEGRAPH to be used in an offline setting: (1) first-party ATS cookie-domain pairs are detected using machine learning classifier and (2) the detected cookie-domain pairs are added to a cookie filter list such as those already supported in privacy-enhancing browser extensions such as uBlock Origin [18] for run-time blocking. We argue that a reasonably frequent (e.g., once a week) deployment of COOKIEGRAPH on a large scale would be sufficient in generating and keeping the filter list up-to-date. While advertisers and trackers can in theory change cookie names at a rate faster than COOKIEGRAPH’s periodic deployment, updating cookie names frequently is challenging in practice because setting these first-party ATS cookies across many different sites requires tight coordination between different entities. To illustrate the practical issues associated with changing cookie names, consider the legacy demdex cookie set by Adobe’s embedded script that is then exfiltrated to the demdex.net domain. Adobe’s documentation explains that it is difficult to change the legacy name because “... it is entwined deeply with Audience Manager, the Adobe Experience Cloud ID Service, and our installed user base” [25], [36]. If advertisers or trackers are somehow able to overcome these practical challenges and change cookie names at a much faster pace, COOKIEGRAPH’s online implementation for run-time cookie classification would be necessary. Further research is needed for efficient and effective online implementation of COOKIEGRAPH.

6. Conclusion

We conducted a large scale differential measurement study to investigate how trackers abuse first-party cookies to circumvent third-party cookie blocking. Our proposed COOKIEGRAPH was able to accurately and robustly block first-party tracking cookies, and significantly outperforming the state-of-the-art. Using COOKIEGRAPH, we found evidence of widespread abuse of first-party cookies on more than 93% of the tested websites by 1500+ distinct tracking domains, which included major advertising entities such as Google as well as many specialized entities such as Criteo.

References

- [1] “About publisher provided identifiers,” <https://web.archive.org/web/20220614165742/https://support.google.com/admanager/answer/2880055?hl=en>.
- [2] “Cartographer identity graph,” <https://web.archive.org/web/20220526085916/https://www.lotame.com/solutions/cartographer-identity-graph/>.
- [3] “Cookieblock,” <https://github.com/dibollinger/CookieBlock>.
- [4] “Criteo Online Identification,” https://web.archive.org/web/20220819071808/https://filecache.investorroom.com/mr5ir_criteo/977/download/Criteo_Online_Identification_May2020.pdf/.
- [5] “fbp and fbc Parameters,” <https://web.archive.org/web/20220722220344/https://developers.facebook.com/docs/marketing-api/conversions-api/parameters/fbp-and-fbc/>.
- [6] “Firefox rolls out total cookie protection by default to all users worldwide,” <https://blog.mozilla.org/en/products/firefox/firefox-rolls-out-total-cookie-protection-by-default-to-all-users-worldwide/>.
- [7] “Firefox’s protection against fingerprinting,” <https://support.mozilla.org/en-US/kb/firefox-protection-against-fingerprinting>.
- [8] “Google Analytics Cookie Usage on Websites,” <https://web.archive.org/web/20220812222800/https://developers.google.com/analytics/devguides/collection/gtagjs/cookie-usage>.
- [9] “Id5 identity cloud,” <https://web.archive.org/web/20220727094611/https://www.id5.io/identity-cloud/>.
- [10] “Identity Guide,” <https://web.archive.org/web/20220115155115/https://yieldbird.com/identity-guide/>.
- [11] “It’s their word against their source code - tiktok report,” <https://internet2-0.com/whitepaper/its-their-word-against-their-source-code-tiktok-report/>.
- [12] “Lotame – Data Collection Guide,” <https://web.archive.org/web/20210730071853/https://my.lotame.com/t/p8hxvnd/data-collection-guide>.
- [13] “Lotame identity resolution,” <https://web.archive.org/web/20220530231410/https://www.lotame.com/solutions/identity-resolution/>.
- [14] “Lotame lightning tag,” <https://web.archive.org/web/20220307010702/https://my.lotame.com/t/m1hxv7l/lotame-lightning-tag>.
- [15] “Our new approach to address the rise of fingerprinting,” <https://blog.disconnect.me/our-new-approach-to-address-the-rise-of-fingerprinting/>.
- [16] “Panorama id,” <https://web.archive.org/web/20220327180718/https://www.lotame.com/panorama/id/>.
- [17] “Tiktok adds third-party cookies to its pixel – and tries to eat facebook’s lunch,” <https://web.archive.org/web/20220623232016/https://www.adexchanger.com/online-advertising/tiktok-adds-third-party-cookies-to-its-pixel-and-tries-to-eat-facebooks-lunch/>.
- [18] “uBlock Origin: Resources Library,” <https://github.com/gorhill/uBlock/wiki/Resources-Library#cookie-removerjs->.
- [19] “Using cookies with tiktok pixel,” <https://web.archive.org/web/20220610074648/https://ads.tiktok.com/help/article?aid=10007540>.
- [20] “What facebook’s first-party cookie means for adtech,” <https://web.archive.org/web/20220729210450/https://clearcode.cc/blog/facebook-first-party-cookie-adtech/>.
- [21] “This bug in your pc is a smart cookie,” <https://archive.org/details/FinancialTimes1996UKEnglish,1996>.
- [22] “Internet privacy with ie6 and p3p: A summary of findings,” <http://web.archive.org/web/20200731061208/http://www.spywarewarrior.com/uiuc/ie6-p3p.htm>, 2001.
- [23] “Adblock plus,” <https://adblockplus.org/>, 2022. [Online]. Available: <https://adblockplus.org/>
- [24] “Attentive cookie,” <https://docs.attentivemobile.com/pages/developer-guides/third-party-integrations/referral-marketing-platforms/talkable/>, 2022. [Online]. Available: <https://docs.attentivemobile.com/pages/developer-guides/third-party-integrations/referral-marketing-platforms/talkable/>
- [25] “Cookies and the experience cloud identity service,” <https://experienceleague.adobe.com/docs/id-service/using/intro/cookies.html?lang=en>, 2022. [Online]. Available: <https://experienceleague.adobe.com/docs/id-service/using/intro/cookies.html?lang=en>
- [26] “Disconnect tracking protection lists,” <https://disconnect.me/trackerprotection>, 2022. [Online]. Available: <https://disconnect.me/trackerprotection>

- [27] “Doubleclick,” <https://web.archive.org/web/19970405225532/http://www.doubleclick.com/>, 2022.
- [28] “Easylist,” <https://easylist.to/easylist/easylist.txt>, 2022.
- [29] “Easyprivacy,” <https://easylist.to/easylist/easyprivacy.txt>, 2022.
- [30] “Enhanced tracking protection in firefox for desktop,” <https://support.mozilla.org/en-US/kb/enhanced-tracking-protection-firefox-desktop>, 2022.
- [31] “Hubspot cookie,” <https://knowledge.hubspot.com/reports/what-cookies-does-hubspot-set-in-a-visitor-s-browser>, 2022. [Online]. Available: <https://knowledge.hubspot.com/reports/what-cookies-does-hubspot-set-in-a-visitor-s-browser>
- [32] “Id5 - first party ids and identity resolution methods explained,” <https://web.archive.org/web/20220408035339/https://id5.io/news/index.php/2022/03/24/first-party-ids-and-identity-resolution-methods-explained/>, 2022.
- [33] “Omnisend cookie,” <https://support.omnisend.com/en/articles/1933402-explaining-and-managing-tracking-cookies>, 2022. [Online]. Available: <https://support.omnisend.com/en/articles/1933402-explaining-and-managing-tracking-cookies>
- [34] “One trust. cookiepedia,” <https://cookiepedia.co.uk>, 2022.
- [35] “Tracking prevention in microsoft edge,” <https://docs.microsoft.com/en-us/microsoft-edge/web-platform/tracking-prevention>, 2022.
- [36] “Understanding calls to the demdex domain,” <https://experienceleague.adobe.com/docs/audience-manager/user-guide/reference/demdex-calls.html?lang=en>, 2022. [Online]. Available: <https://experienceleague.adobe.com/docs/audience-manager/user-guide/reference/demdex-calls.html?lang=en>
- [37] M. Alrizah, S. Zhu, X. Xing, and G. Wang, “Errors, misunderstandings, and attacks: Analyzing the crowdsourcing process of ad-blocking systems,” in *Proceedings of the 2019 Internet Measurement Conference (IMC)*, 2019.
- [38] W. Aqeel, B. Chandrasekaran, A. Feldmann, and B. M. Maggs, “On landing and internal web pages: The strange case of jekyll and hyde in web performance measurement,” in *Proceedings of the ACM Internet Measurement Conference*, 2020.
- [39] P. N. Bahrami, U. Iqbal, and Z. Shafiq, “Fp-radar: Longitudinal measurement and early detection of browser fingerprinting,” in *Proceedings on Privacy Enhancing Technologies (PETS)*, 2022.
- [40] D. Bollinger, “Analyzing Cookies Compliance with the GDPR,” <https://www.research-collection.ethz.ch/handle/20.500.11850/477333>. Thesis, ETH Zurich.
- [41] D. Bollinger, K. Kubicek, C. Cotrini, and D. Basin, “Automating cookie consent and GDPR violation detection,” in *31st USENIX Security Symposium (USENIX Security 22)*. USENIX Association, 2022.
- [42] —, “Automating cookie consent and gdpr violation detection,” in *31st USENIX Security Symposium (USENIX Security 22)*, 2022.
- [43] A. Cahn, S. Alfeld, P. Barford, and S. Muthukrishnan, “An empirical study of web cookies,” in *Proceedings of the 25th International Conference on World Wide Web*. International World Wide Web Conferences Steering Committee, 2016, p. 891–901.
- [44] Q. Chen, P. Ilia, M. Polychronakis, and A. Kapravelos, “Cookie swap party: Abusing first-party cookies for web tracking,” in *Proceedings of the Web Conference*, 2021.
- [45] Q. Chen and A. Kapravelos, “Mystique: Uncovering information leakage from browser extensions,” in *Proceedings of the 2018 ACM SIGSAC Conference on Computer and Communications Security*, 2018, pp. 1687–1700.
- [46] A. Chudnov and D. A. Naumann, “Inlined information flow monitoring for javascript,” in *Proceedings of the 22nd ACM SIGSAC Conference on Computer and Communications Security*, 2015, pp. 629–643.
- [47] L. M. D. Kristol, “Http state management mechanism,” <https://datatracker.ietf.org/doc/html/rfc2109>, 1997.
- [48] S. Dambra, I. Sanchez-Rola, L. Bilge, and D. Balzarotti, “When sally met trackers: Web tracking from the users’ perspective,” in *USENIX Security Symposium*, 2022.
- [49] H. Dao, J. Mazel, and K. Fukuda, “Cname cloaking-based tracking on the web: Characterization, detection, and protection,” *IEEE Transactions on Network and Service Management*, 2021.
- [50] Y. Dimova, G. Acar, L. Olejnik, W. Joosen, and T. Van Goethem, “The CNAME of the Game: Large-scale Analysis of DNS-based Tracking Evasion,” *PETS*, 2021.
- [51] Díaz-Morales and Roberto, “Cross-device tracking: Matching devices and cookies,” in *2015 IEEE International Conference on Data Mining Workshop (ICDMW)*, 2015, pp. 1699–1704.
- [52] B. Eich, “C is for cookie,” <https://brendaneich.com/2013/05/c-is-for-cookie/>, 2013.
- [53] —, “The cookie clearinghouse,” <https://brendaneich.com/2013/06/the-cookie-clearinghouse/>, 2013.
- [54] S. Englehardt and A. Narayanan, “Online tracking: A 1-million-site measurement and analysis,” in *Proceedings of ACM CCS 2016*, 2016.
- [55] S. Englehardt, D. Reisman, C. Eubank, P. Zimmerman, J. Mayer, A. Narayanan, and E. W. Felten, “Cookies that give you away: The surveillance implications of web tracking,” in *Proceedings of the 24th International Conference on World Wide Web*, 2015.
- [56] I. Fouad, N. Bielova, A. Legout, and N. Sarafijanovic-Djukic, “Missed by filter lists: Detecting unknown third-party trackers with invisible pixels,” *Proceedings on Privacy Enhancing Technologies*, vol. 2020, pp. 499–518, 04 2020.
- [57] I. Fouad, C. Santos, A. Legout, and N. Bielova, “My cookie is a phoenix: detection, measurement, and lawfulness of cookie respawning with browser fingerprinting,” in *Privacy Enhancing Technologies Symposium (PETS)*, 2022.
- [58] B. Fulgham, “Protecting against hsts abuse,” <https://webkit.org/blog/8146/protecting-against-hsts-abuse/>, 2018.
- [59] Google, “The privacy sandbox,” <https://developer.chrome.com/docs/privacy-sandbox/>.
- [60] D. Hedin, A. Birgisson, L. Bello, and A. Sabelfeld, “Jsflow: Tracking information flow in javascript and its apis,” in *Proceedings of the 29th Annual ACM Symposium on Applied Computing*, 2014, pp. 1663–1671.
- [61] L. Hieu, M. Athina, and S. Zubair, “Cv-inspector: Towards automating detection of adblock circumvention,” in *Network and Distributed System Security Symposium (NDSS)*, 2021.
- [62] M. Hils, D. W. Woods, and R. Böhme, “Measuring the emergence of consent management on the web,” in *Proceedings of the ACM Internet Measurement Conference*, 2020.
- [63] X. Hu, N. Sastry, and M. Mondal, “Cccc: Corralling cookies into categories with cookiemonster,” in *13th ACM Web Science Conference 2021*. Association for Computing Machinery, 2021, p. 234–242.
- [64] U. Iqbal, Z. Shafiq, and Z. Qian, “The ad wars: Retrospective measurement and analysis of anti-adblock filter lists,” in *IMC*, 2017.
- [65] U. Iqbal, P. Snyder, S. Zhu, B. Livshits, Z. Qian, and Z. Shafiq, “Adgraph: A graph-based approach to ad and tracker blocking,” in *IEEE Symposium on Security and Privacy (S&P)*. IEEE, 2020.
- [66] U. Iqbal, C. Wolfe, C. Nguyen, S. Englehardt, and Z. Shafiq, “Khaleesi: Breaker of advertising and tracking request chains,” in *USENIX Security Symposium (USENIX)*, 2022.
- [67] P. Laperdrix, W. Rudametkin, and B. Baudry, “Beauty and the beast: Diverting modern web browsers to build unique browser fingerprints,” in *2016 IEEE Symposium on Security and Privacy (SP)*, 2016.

- [68] S. Lekies, B. Stock, and M. Johns, “25 million flows later: Large-scale detection of dom-based xss,” in *Proceedings of the 2013 ACM SIGSAC conference on Computer and Communications Security*, 2013, pp. 1193–1204.
- [69] P. G. Leon, L. F. Cranor, A. M. McDonald, and R. McGuire, “Token attempt: the misrepresentation of website privacy policies through the misuse of p3p compact policy tokens,” in *Proceedings of the 9th Annual ACM Workshop on Privacy in the Electronic Society*, 2010.
- [70] L. Montulli, “The reasoning behind web cookies,” <http://montulli.blogspot.com/2013/05/the-reasoning-behind-web-cookies.html>, 2013.
- [71] N. Nguyen, “Latest firefox rolls out enhanced tracking protection,” <https://blog.mozilla.org/en/products/firefox/latest-firefox-rolls-out-enhanced-tracking-protection/>, 2018.
- [72] P. Papadopoulos, N. Kourtellis, and E. P. Markatos, “Cookie synchronization: Everything you always wanted to know but were afraid to ask,” in *Proceedings of the World Wide Web (WWW) Conference*, 2019.
- [73] A. Randall, P. Snyder, A. Ukani, A. Snoeren, G. Voelker, S. Savage, and A. Schulman, “Trackers bounce back: Measuring evasion of partitioned storage in the wild,” 2022.
- [74] F. Roesner, T. Kohno, and D. Wetherall, “Detecting and defending against third-party tracking on the web,” in *9th USENIX Symposium on Networked Systems Design and Implementation (NSDI 12)*, 2012, pp. 155–168.
- [75] I. Sanchez-Rola, M. Dell’Amico, D. Balzarotti, P.-A. Vervier, and L. Bilge, “Journey to the center of the cookie ecosystem: Unraveling actors’ roles and relationships,” in *S&P 2021, 42nd IEEE Symposium on Security & Privacy, 23-27 May 2021, San Francisco, CA, USA*, 2021.
- [76] J. Schuh, “Building a more private web: A path towards making third party cookies obsolete,” <https://blog.chromium.org/2020/01/building-more-private-web-path-towards.html>, 2020.
- [77] S. Siby, U. Iqbal, S. Englehardt, Z. Shafiq, and C. Troncoso, “Web-graph: Capturing advertising and tracking information flows for robust blocking,” in *31st USENIX Security Symposium (USENIX Security 22)*. USENIX Association, 2022.
- [78] A. Sjösten, P. Snyder, A. Pastor, P. Papadopoulos, and B. Livshits, “Filter list generation for underserved regions,” in *WWW*, 2020.
- [79] S. Sluis, “Google is building integrations for publisher-specific identifiers,” <https://www.adexchanger.com/platforms/google-is-building-integrations-for-publisher-specific-identifiers/>, 2021.
- [80] B. Stock, S. Lekies, T. Mueller, P. Spiegel, and M. Johns, “Precise client-side protection against dom-based cross-site scripting,” in *23rd USENIX Security Symposium (USENIX Security 14)*, San Diego, CA, 2014, pp. 655–670.
- [81] B. P. Team, “Fighting CNAME Trickery,” <https://brave.com/privacy-updates/6-cname-trickery/>, 2020.
- [82] M. E. Team, “Introducing tracking prevention, now available in microsoft edge preview builds,” <https://blogs.windows.com/msedgedev/2019/06/27/tracking-prevention-microsoft-edge-preview/>, 2022. [Online]. Available: <https://blogs.windows.com/msedgedev/2019/06/27/tracking-prevention-microsoft-edge-preview/>
- [83] A. Vastel, P. Laperdrix, W. Rudametkin, and R. Rouvoy, “Fp-stalker: Tracking browser fingerprint evolutions,” in *IEEE Symposium on Security and Privacy (SP)*, 2018.
- [84] A. V. Veen and A. de Vries, “Cookie compliance of dutch hospital websites,” 2021.
- [85] WebKit, “Tracking prevention in webkit,” <https://webkit.org/tracking-prevention/>, 2022. [Online]. Available: <https://webkit.org/tracking-prevention/>
- [86] J. Wilander, “Intelligent tracking prevention,” <https://webkit.org/blog/7675/intelligent-tracking-prevention/>, 2017.
- [87] —, “Intelligent tracking prevention 1.1,” <https://webkit.org/blog/8142/intelligent-tracking-prevention-1-1/>, 2018.
- [88] —, “Intelligent tracking prevention 2.0,” <https://webkit.org/blog/8311/intelligent-tracking-prevention-2-0/>, 2018.
- [89] —, “Intelligent tracking prevention 2.1,” <https://webkit.org/blog/8613/intelligent-tracking-prevention-2-1/>, 2019.
- [90] —, “Intelligent tracking prevention 2.2,” <https://webkit.org/blog/8828/intelligent-tracking-prevention-2-2/>, 2019.
- [91] —, “Intelligent tracking prevention 2.3,” <https://webkit.org/blog/9521/intelligent-tracking-prevention-2-3/>, 2019.
- [92] —, “Cname cloaking and bounce tracking defense,” <https://webkit.org/blog/11338/cname-cloaking-and-bounce-tracking-defense/>, 2020.
- [93] —, “Full third-party cookie blocking and more,” <https://webkit.org/blog/10218/full-third-party-cookie-blocking-and-more/>, 2020.
- [94] —, “Bounce tracking protection,” <https://github.com/privacypg/proposals/issues/6>, 2022.

Appendix

1. Case Studies

In this section, we look at case studies of ATSEs identified in Section 3.3 which are found to be extensively using first-party cookies for tracking purposes. We analyze the behavior of these ATSEs in our crawls, compare the observed behavior with their documentation, and create a generic model which all first-party-cookie-based ATSEs follow in Section 3.4. We present case studies of three ATSEs here: Lotame, ID5, and Criteo.

1.1. Lotame. Lotame is a data and identity management solution which claims to provide a single ID to users across multiple browsers, devices, and platforms. Lotame’s Lightning Tag [14] packages the user visit data in a JSON object and sends it to its servers. Code 2 shows an example payload sent to Lotame. The payload includes IDs assigned by the website, third-party identifiers present on the site, certain user behaviors (configured through collaboration between the publisher and Lotame), and other custom rules defined per website [12]. Lotame processes the payload and matches the data with its *Cartographer Identity Graph* [2], and sends back an ID, called *panoramaID* [16], which is stored as a first-party cookie or in *localStorage*.

1.2. ID5 Universal ID. ID5 provides identity resolution for publishers and advertisers through its *Identity Cloud* [9]. ID5’s script packages a payload that contains several deterministic identifiers, such as email, usernames, and phone numbers (if available) and as well as probabilistic identifiers include, such as IP address, user agent, and location of the user [32]. ID5 then processes the payload and matches the data with its Identity Cloud and send back an ID, called *universal_id*, which is stored as a first-party cookie and as well as in local storage. An example payload from ID5 is shown in Figure 3. We note that ID5 also provides *Partner Graph*, a service that enables information sharing among its partners [9]. Partner Graph allows different identify providers to exchange information with each other.

```
1 {
2   "created_at": "2022-02-09T11:42:40.817811Z",
3   "id5_consent": true,
4   "original_uid": "ID5*
5     FnFOGLkYzdJjuoK3KvAecVW2oFpZ7OrZiW7h-M0H
6     ACAHYuWkxQrEGcpWuOkQUXbHB2008Rj0wt94j1lT
7     WHQ6wdkqOwSbnYea8cesuONCF4HZeIoDaB_TwBsy
8     lKrs3tHB2Y87ZwP0DrpYlGz1OG1Fgdn0YdgqoSGU
9     SGxzS1gUzsHaMIUBVqf2I08es6aUULEB2n48oyL0
10    nGnRtstVqtcQQdqS3Aay4Hhgzbh9gIZyYHa_nLT
11    d5rjbbR0ZXwkXDzB2yU1XUC2duk1p1J_c1VAgdt
12    xC_xaRRBOLi0fnvp9cHbqr_pWihTtaUMS_R6eLuB
13    2_AMExt1UdhJZBe2mcXZAdwm91cbeMMv1pg3MBRc
14    oHcUgzNypi-5xLUqBD8GC4B3KsefcNkiDvI4n9ZL
15    70jAdzqB9PD-KczAx63Ck0gEIHdNPFQeE1-f5VaO
16    OEhf6B3VUqDoL1lhqVoIUdhKJb9gd2kp0mgXabhwJ
17    tP07sgWwHd_vz_uIYYmqQBtH-JFVb3h1-kI9GQv
18    dby2PyftDawd596ho3tuOsKtoDok4S4Her2Uw-_u
19    BYRxt6YzVYqB3tRwTVI3Fxm8cGJyJdmYAd881om
20    BIpK0eg2Ok4VTnc",
21   "universal_uid": "ID5*
22     HGH7W7iMpMu3-EPZCXUuqNBB7fFHUUvcBsdSSG
23     Fu5UHYucsBxMz2jncvKS7rkwlB2MwiiPupapPxa
24     79eieMAdkTyMQz82slvIekPr28DEHZbqTCrapj9
25     Fb9K0x4zj1B2YHOKNDwQY6mZwxk_lmWAdna3wWna
26     hrpMEUrPxJSnAHaPYB-InS5DXGpQgqbqirB2nHFI
27     D4j9i9BgcP3k0VygqdtFhsT7eedFFYuB8EQ0Ha4
28     -yV9Ifvbvi5oxmtH7HB2xg-mmmOeyVOPBYG2tfw
29     dtREZnUE83cfn_LhVhvu4HbvKlkwEFJiddOE4PT
30     ZbB2-de_VPyKHax5Jtp046xwdwZ_OUMgANOsZygV
31     0SrrMHcZ37qQB-LkCO4tWoTbv_B3KMGCmrebcfLE
32     TeCn0AEGdzIRlutDJZM6AaiL9KVKAHdPrtAtTv73
33     ZyDg92Rq-_B3XeRNOoc7b2CEBs1lXO1Qd2sfmR36
34     NyW-dsK9CUmd4Hd3vcr1AWzfYEFw01Q5J1B3ibAF
35     UYrA0XWML-D9jS1Ad5iX1tGA4vPu0wdZkXVOEHek
36     q2xibOm9XwN2nSdzjbB3v8nOyzGuF9QgwI67pMGQ
37     d85BszRCJDUkiiu-tv5BQ",
38   "signature": "
39     ID5_Ab6tnGgmCcjKo-qFGVKsZuNpNePqkOHZT
40     rbCmpuktLLO1NOCALhmY_91AHP8LU0BvfJT2Q
41     JQWlsUEfynB1hbGZc",
42   "link_type": 1,
43   "cascade_needed": true,
44   "privacy": {
45     "jurisdiction": "other",
46     "id5_consent": true
47   }
48 }
```

Code 3. Example of data structure received from ID5 during a user’s first visit.

1.3. Criteo. Criteo provides *Criteo Identity Graph* for identity resolution [4]. Criteo Identity Graph is built from four different sources: (i) data contributed by advertisers, (ii) data collected from publisher websites by Criteo itself, (iii) data provided by Criteo partners such as LiveRamp and Oracle, (iv) and predictions on existing data by Criteo’s machine learning models. Criteo claims that its identity graph is able to stitch together identifiers from more than 2 billion users across the world, and that it contains persistent deterministic identifiers for 96% of the users [4]. Similar to other identity resolution services, Criteo generates an ID, based on identifiers, such as hashed emails, mobile device IDs, cookie IDs, and stores it in first-party storage as *cto_bundle*. Their documentation shows that Criteo makes use of both first-

```
1 data: {
2   behaviorIds: [1,2,3],
3   behaviors: {
4     int: ['behaviorName', 'behaviorName2'],
5     act: ['behaviorName']
6   },
7   ruleBuilder: {
8     key1: ['value 1a', 'value 1b']
9   },
10  thirdParty: {
11    namespace: 'NAMESPACE',
12    value: 'TPID_VALUE'
13  }
14 }
```

Code 2. Example of data sent structure sent to Lotame during a user’s first visit.

party cookies and `localStorage` for storing `cto_bundle` cookie. We consider this to be one of the fundamental behaviors of first-party ATS cookies. As described in Section 4.1, `COOKIEGRAPH`'s graph representation abstracts storage to refer to both Cookies and `localStorage`. We also include a count of `localStorage` accesses in the feature set computed from the graph representation. Inclusion of these features help `COOKIEGRAPH` effectively model first-party ATS cookies behavior.

2. Cross-Device User Attribution

The methodology for cross-site attribution can also be extended to cross-device attribution. In this slightly more complex scenario, the user is not only visiting different sites but also using different devices with different fingerprints. We show an example of cross-device attribution in Figure 10. Instead of visiting the sites on the same device, the user now visits sites 1-3 on device 1, and then visits sites 4-6 on device 2. Fingerprints F_1, F_2 and F_3 are collected on sites 1-3 while using device 1, and F_4, F_5 and F_6 are collected while using device 2. Sites 3 and 6 ask the user for an additional $PPID - 1$. There is no similarity in fingerprints between the two devices. However, as sites 3 and 6 collect the additional $PPID - 1$, the tracker is able to identify and populate its first-party cookie on each of those sites with the correct user ID (UID_1).

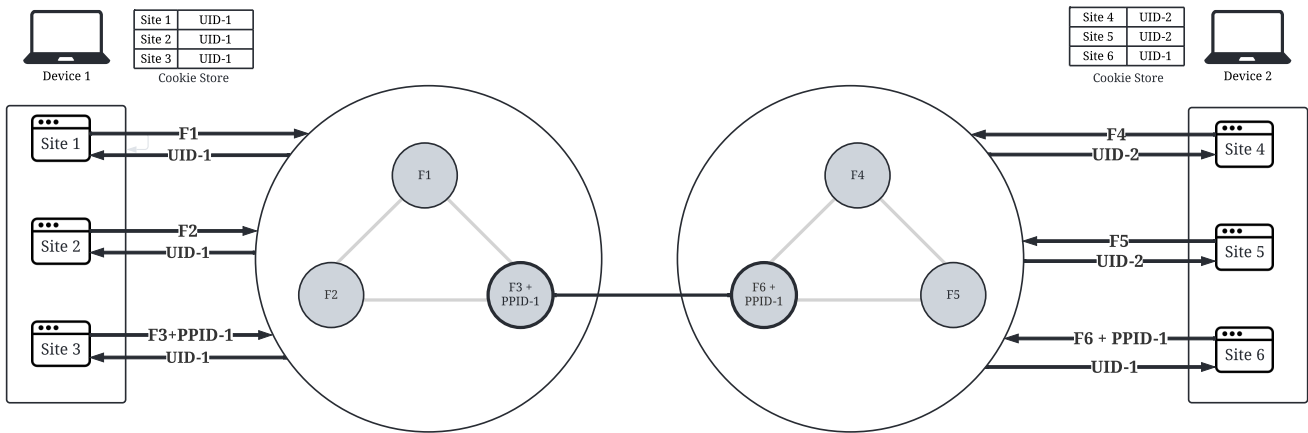

Figure 10. This figure shows the flow of information and identifiers through an identity graph for a cross-device attribution. The user visits sites 1, 2, and 3 via Device 1. The identity graph returns a $UID - 1$ for all the site visits, using a probabilistic matching of fingerprints $F1$, $F2$, and $F3$ sent on each respective website. A Publisher Provided ID $PPID - 1$ is also sent alongside $F3$ when visiting site 3. The user visits sites 4, 5, and 6 through a new Device 2. Because the fingerprints $F4$ and $F5$ are different from $F1$, $F2$, and $F3$, the identity graph returns a new $UID - 2$ for these site visits. On site 6, the website obtains and sends a Publisher Provided ID which matches $PPID - 1$ provided on site 3. As a result, the identity graph matches and returns the existing user's $UID - 1$ for site 6.