

A Comparison of Deep Learning MOS Predictors for Speech Synthesis Quality

Alessandro Ragano¹, Emmanouil Benetos², Michael Chinen³, Helard B Martinez¹,
Chandan K A Reddy³, Jan Skoglund³, Andrew Hines¹

¹University College Dublin, School of Computer Science, Dublin, Ireland

²Queen Mary University of London, School of EECS, London, UK

³Google LLC, San Francisco, CA, USA

alessandro.ragano@ucdconnect.ie, emmanouil.benetos@qmul.ac.uk,
{mchinen, chandanka, jks}@google.com, {andrew.hines, helard.becerra}@ucd.ie

Abstract

This paper introduces a comparison of deep learning-based techniques for the MOS prediction task of synthesised speech in the Interspeech VoiceMOS challenge. Using the data from the main track of the VoiceMOS challenge we explore both existing predictors and propose new ones. We evaluate two groups of models: NISQA-based models and techniques based on fine-tuning the self-supervised learning (SSL) model wav2vec2_base. Our findings show that a simplified version of NISQA with 40% fewer parameters achieves results close to the original NISQA architecture on both utterance-level and system-level performances. Pre-training NISQA with the NISQA corpus improves utterance-level performance but shows no benefit on the system-level performance. Also, the NISQA-based models perform close to LDNet and MOSANet, 2 out of 3 baselines of the challenge. Fine-tuning wav2vec2_base shows superior performance than the NISQA-based models. We explore the mismatch between natural and synthetic speech and discovered that the performance of the SSL model drops consistently when fine-tuned on natural speech samples. We show that adding CNN features with the SSL model does not improve the baseline performance. Finally, we show that the system type has an impact on the predictions of the non-SSL models.

Index Terms: speech quality prediction, speech synthesis

1. Introduction and Related Work

Text-to-speech (TTS) and voice conversion (VC) are two fundamental speech synthesis tasks [1, 2]. The perceptual quality of speech synthesis affects the acceptability of a system and needs to be evaluated. Subjective listening tests are the most reliable way to assess speech synthesis quality but they are time-consuming and not usable in real-time applications. Objective quality metrics have been proposed to predict the mean opinion score (MOS) without human intervention [3]. A state-of-art evaluation of speech synthesis systems published in 2018 [4] calls for some new best practices in speech synthesis research. Among the best practices, the authors analysed some issues with objective metrics for TTS. For instance, some objective metrics developed for natural speech have been adapted to evaluate speech synthesis but they tend to focus on spectral features and consider prosody as a secondary problem. Evaluating speech synthesis quality with objective metrics suffers from generalization when evaluated on unseen speech synthesis systems or unseen listening tests used to collect the ground truth. To tackle the above-mentioned challenges, deep learning-based MOS predictors emerged and the VoiceMOS challenge has been

proposed. The VoiceMOS challenge goal is to predict MOS of synthesised speech encouraging data-driven approaches.

In this section, we briefly describe some of the existing deep learning-based MOS prediction techniques. AutoMOS [5] learns a mapping between MOS and raw waveform. It is based on a family of models based on Long Short-Term Memory (LSTM) networks. AutoMOS has been trained and evaluated on one speaker only. However, the speaker relevantly affects the quality of TTS systems [6] which calls to evaluate AutoMOS in a multi-speaker scenario. MOSNet [7] is a model based on combining convolutional neural networks (CNNs) and recurrent neural networks (RNNs) designed for VC system quality. MOSNet performs well on system-level and fairly on utterance-level [7]. A similar trend has been found on the VoiceMOS challenge test set [3] when fine-tuning the pre-trained MOSNet on the VoiceMOS challenge training set with data augmentation. It must be noted that MOSNet trained from scratch and the pre-trained MOSNet without fine-tuning perform poorly on the challenge dataset [3]. In addition, it has been found that MOSNet suffers when evaluating the quality of real-world speech recordings [8]. LDNet [9] is a network that uses individual listener ratings to predict MOS. The speech signal and the listener ID are both used as input of one individual network. LDNet represents one of the 3 baselines used for the VoiceMOS challenge. Another baseline proposed for the challenge is fine-tuning the self-supervised learning (SSL) model wav2vec2_large and wav2vec2_base [10]. Fine-tuning SSL models showed promising performance in audio tasks [11] and other speech tasks [12], even surpassing supervised learning approaches.

Motivated by the availability of the task and the datasets provided by the challenge, we contribute as follows. First, we study how MOS predictors proposed for natural speech perform on synthetic speech and we propose a model based on CNNs and temporal max pooling. Next, we explore if the fine-tuned wav2vec2_base model could be improved and analyse the mismatch between natural speech and synthetic speech. Finally, we evaluate the performance by the system type.

2. Compared Models

2.1. CNN with Temporal Max Pooling

In this section we describe a model based on CNNs that we propose for the VoiceMOS challenge. Learning features from log Mel spectrograms with 2D CNNs has been proven to be promising for speech quality prediction [13, 14]. Our model consists of CNN with temporal max pooling (CMP) which is based on the same framewise CNN of NISQA [13]. NISQA is

a MOS predictor developed for speech quality prediction which was not originally evaluated on speech synthesis. The NISQA convolutional network maps a spectrogram patch of size 48×15 (48 Mel bands, 15 time frames) to $6 \times 1 \times 64$ features where 64 is the number of filters of the last convolutional layer. Unlike NISQA which uses self-attention to model the time dependency and temporal attention pooling, we simplify the network. We connect a global pooling layer (GAP) to get $1 \times 1 \times 64$ for each spectrogram patch and we use temporal max pooling to squeeze the time dimension obtaining 64 features for each speech sample. After max pooling, we connect an output layer that predicts MOS. Using temporal max pooling gives us a model 40% smaller than NISQA in terms of the number of parameters ($\approx 135\text{K}$ vs. $\approx 218\text{K}$).

2.2. Pre-Trained CNN with Temporal Max Pooling

Given the availability of large unlabelled speech data, we pre-train the convolutional part of CMP with a convolutional autoencoder (CMP-AE) trained on a different unlabelled dataset. Deep autoencoder features have been already used for non-intrusive speech [15, 14] and audio-video quality prediction [16]. The encoder uses the same CNN as NISQA. After the CNN we connect a global pooling layer (GAP) as in CMP to get $1 \times 1 \times 64$. This is followed by a linear layer that compresses each spectrogram patch to a representation of size 1×10 . This last linear layer is discarded when fine-tuning to predict MOS. We noticed that GAP combined with a linear layer showed a more robust representation than attaching directly a linear layer after the convolutional network. In this way, the network has fewer parameters, which reduces training and inference time. The decoder is composed of a linear layer (from 1×10 to 1×384), reshaping to a tensor of size $6 \times 1 \times 64$, and 3 transposed convolutional layers that reconstruct each spectrogram patch.

2.3. Self-Supervised Learning (SSL) Models

The models `wav2vec2_large` and `wav2vec2_base` fine-tuned on the VoiceMOS training set are the best challenge baselines [3]. In our experiments, we use `wav2vec2_base` that maps each waveform time frame to 768 features. We explore if adding different features to `wav2vec2_base` would further improve MOS prediction performance.

The method is illustrated in Fig 1. The network combines the following features: features extracted from the fine-tuned `wav2vec2_base` model on the VoiceMOS training set (1×768), the predicted MOS of the fine-tuned `wav2vec2_base` model (1×1), and features from the temporal max pooling layer of CMP-AE. The output layer maps all the features ($1 \times (768 + 1 + 64)$) to a single value which is the predicted MOS. This method described above is called CMP-AE+wM+wF where wM indicates the `wav2vec2_base` MOS and wF refers to the `wav2vec2_base` features. We also evaluate a combination of MOS and CMP-AE only (CMP-AE+wM)

During training, we learn the weights of the output layer and we fine-tune the CNN of CMP-AE. We do not further fine-tune the `wav2vec2_base` model with its output layer.

3. Training

In our experiments we use 3 datasets. The VoiceMOS dataset provided by the challenge, the NISQA corpus¹, and the PSTN

¹<https://github.com/gabrielmittag/NISQA>

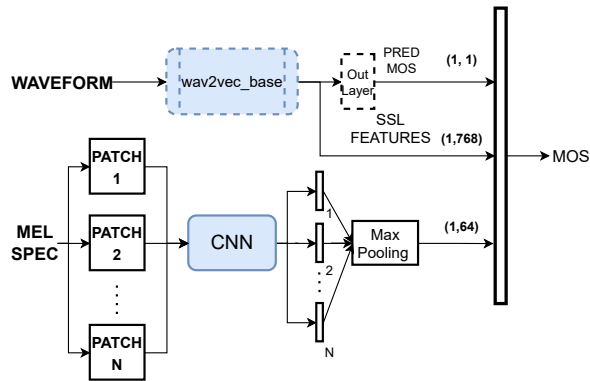

Figure 1: Schematic diagram of the MOS regression network. The CNN is pre-trained with the autoencoder and fine-tuned during training together with the output layer that predicts the final MOS.

corpus [17]. From the VoiceMOS challenge we only use the main track which does not include out-of-domain data. The VoiceMOS dataset is composed of 187 speech synthesis systems including TTS, VC, and natural speech. The speech synthesis systems include the ones from the Blizzard challenge (BC), from the voice conversion challenge (VCC), and ESPNet systems². Speech is synthesised with several utterances and in a multi-speaker setting. A listening test has been conducted collecting 8 rates for each speech sample [18]. The NISQA corpus has been designed to develop and evaluate NISQA. It is composed of 14K natural speech samples degraded with both real-world conditions (e.g. video call services and mobile phones) and synthetic degradations (e.g. codecs, background noise). From the NISQA corpus we only used the training set as described in the next section. The PSTN corpus includes $\approx 80\text{K}$ speech samples with public switched telephone network degradations obtained with real phone calls.

The SSL-based models are trained on the VoiceMOS training set using the Adam optimizer with a learning rate 0.001 and batch size 4. We minimize the L_1 loss function. To control overfitting we use early stopping with mean squared error (MSE) and set patience equal to 20 epochs. We also fine-tune `wav2vec2_base` on the training set of the NISQA corpus and a subset of PSTN corpus with the same hyper-parameters used for the VoiceMOS training set.

CMP-AE and CMP are trained on the VoiceMOS training set with the same hyperparameters and same early stopping except for the batch size which is increased to 32. The autoencoder is trained on the LbriSpeech100hr dataset [19] using Adam optimizer with a learning rate 0.001 and batch size 32. We stopped training after 200 epochs.

4. Results

Performance evaluation is conducted with the same metrics of the challenge and consists of MSE, Spearman’s rank correlation coefficient (SRCC), linear correlation coefficient (LCC) and Kendall’s tau coefficient (KTAU). Each metric is calculated on utterance-level i.e. ground truth MOS against predicted MOS on each speech sample and on system-level where every utterance is aggregated by synthesis system. The following proposed models are evaluated:

²<https://github.com/espnet/espnet>

Table 1: *Validation Set Results.*

	Utterance Level				System Level			
	MSE	SRCC	LCC	KTAU	MSE	SRCC	LCC	KTAU
CMP	0.331	0.780	0.776	0.587	0.169	0.885	0.881	0.705
CMP-AE	0.318	0.792	0.794	0.600	0.130	0.905	0.906	0.735
CMP-AE+wM	0.199	0.876	0.875	0.699	0.086	0.941	0.938	0.799
CMP-AE+wM+wF	0.184	0.880	0.882	0.706	0.077	0.942	0.946	0.804
NISQA Scratch	0.332	0.798	0.798	0.606	0.183	0.877	0.884	0.71
NISQA Pre-Trained	0.373	0.808	0.812	0.621	0.252	0.886	0.894	0.721
wav2vec2_base	0.325	0.871	0.871	0.693	0.184	0.949	0.944	0.811
wav2vec2_base NC	0.570	0.562	0.570	0.400	0.337	0.667	0.665	0.482
wav2vec2_base PSTN	1.587	0.770	0.730	0.578	1.290	0.863	0.804	0.670

Table 2: *Test Set Results*³.

	Utterance Level				System Level			
	MSE	SRCC	LCC	KTAU	MSE	SRCC	LCC	KTAU
CMP	0.325	0.790	0.790	0.601	0.169	0.872	0.874	0.696
CMP-AE	0.321	0.792	0.800	0.609	0.165	0.883	0.890	0.707
CMP-AE+wM	0.206	0.875	0.879	0.702	0.125	0.920	0.927	0.766
CMP-AE+wM+wF	0.205	0.877	0.878	0.701	0.116	0.925	0.927	0.776
NISQA Scratch	0.327	0.797	0.801	0.614	0.171	0.883	0.880	0.709
NISQA Pre-Trained	0.299	0.825	0.832	0.644	0.157	0.878	0.884	0.705
wav2vec2_base	0.263	0.872	0.875	0.697	0.130	0.915	0.922	0.758
wav2vec2_base NC	0.566	0.600	0.609	0.428	0.412	0.700	0.709	0.506
wav2vec2_base PSTN	1.222	0.793	0.757	0.596	1.017	0.819	0.803	0.621
wav2vec2_large	0.277	0.869	0.869	0.690	0.148	0.924	0.921	0.769
MOSA-Net	0.309	0.809	0.811	0.621	0.162	0.899	0.900	0.729
LDNet	0.334	0.787	0.785	0.599	0.178	0.873	0.873	0.691

- **CMP** is the model using the NISQA framewise CNN model with temporal max pooling. The model weights are randomly initialized.
- **CMP-AE** is CMP where the CNN is pre-trained with the autoencoder.
- **CMP-AE+wM** combines CMP-AE with the predicted MOS of wav2vec2_base.
- **CMP-AE+wM+wF** is the model illustrated in Fig. 1 which combines CMP-AE with predicted MOS of wav2vec2_base and wav2vec2_base features.

It must be noted that CMP and CMP-AE use a shifted and scaled sigmoid in the output layer to make sure that the predicted MOS is within the range 1–5. We noticed that on these 2 models the sigmoid improved both utterance-level and system-level performance on the validation set. The usage of the sigmoid turned out to be not useful for all the other models which are trained without it. The results on the validation and test set are shown in Table 1 and Table 2 respectively. The state-of-the-art models include:

- **NISQA Scratch** is NISQA best version as reported in [13] with self-attention and temporal attention pooling trained on the VoiceMOS challenge training set.
- **NISQA Pre-Trained** is the same model of NISQA Scratch but pre-trained on the NISQA Corpus.
- **wav2vec2_base** is the SSL wav2vec2_base model with an output layer fine-tuned on the VoiceMOS challenge training set.
- **wav2vec2_base NC** is the SSL wav2vec2_base model fine-tuned on the training sets of the NISQA corpus.

We used this model to evaluate how wav2vec2_base fine-tuned on natural speech performs on synthetic speech.

- **wav2vec2_base PSTN** is the SSL wav2vec2_base model fine-tuned on a subset of the PSTN dataset. We extract 7K speech samples to avoid using a dataset too much larger than the VoiceMOS training set. We made sure to have a similar MOS distribution of the full size dataset. This model is also used to evaluate the mismatch between fine-tuning on natural speech and testing on synthetic speech.
- **wav2vec2_large** is the SSL wav2vec2_large model with an output layer fine-tuned on the VoiceMOS challenge training set. It is the best baseline for the challenge.
- **MOSA-Net** is the second baseline of the challenge originally proposed for speech quality prediction which uses a CNN-RNN architecture and both time and spectral features [20].
- **LDNet** is the third baseline of the challenge which we already described in Section 1.

The models CMP-AE+wM+wF and CMP-AE+wM show better results than the baseline wav2vec2_base on the test set on all the metrics. Fine-tuning wav2vec2_base with natural speech (PSTN and NISQA corpus) shows lower performance than fine-tuning with the VoiceMOS training set. This suggests that fine-tuning using a dataset that is out-of-domain is a weaker approach. Also, the models that are fine-tuned with natural speech show worse results than the non-SSL models.

4.1. Performance Analysis Based on the System Type

We evaluated the performance of some models based on the system type: BC, VCC, and ESPNet. The results including system MSE and system SRCC are shown in Fig. 2.

All the models perform better on the VCC data. The worst system MSE is obtained on the BC systems and the worst SRCC is on the ESPNet systems. Pre-training with the autoencoder (CMP-AE) has a positive impact with respect to the non pre-trained version (CMP) on BCC and VC systems. For ESPNet data there is a performance drop when evaluated with SRCC. It must be noted that the performance drop on the ESPNet does not have a huge impact on the overall performance (Table 2) because the test set includes more BC and VCC data than ESPNet. So, overall CMP-AE performs better than CMP for system SRCC as discussed in the section above. Similarly NISQA pre-trained shows a performance drop compared to NISQA from scratch for system MSE on ESPNet but better performance on BCC and VC. This means that for the ESPNet systems the performance indicates a case of negative transfer for both LibriSpeech data (CMP-AE vs CMP) and the NISQA corpus (NISQA pre-trained vs NISQA scratch).

CMP shows higher SRCC than NISQA scratch on the ESPNet systems and very close SRCC on BC and VCC data. This result is in contrast with the evaluation performance conducted on natural speech [13] where the self-attention layer with temporal attention pooling performs better than more simple approaches such as temporal max pooling or temporal average pooling.

³Performance of wav2vec2_large, MOSA-Net, and LDNet are provided by the challenge organisers.

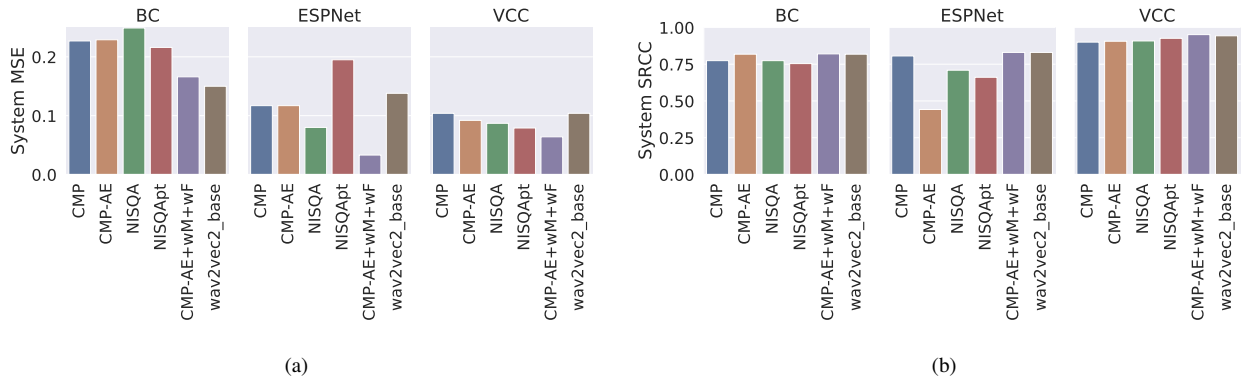

Figure 2: Performance evaluation using system MSE (a) and system SRCC (b) based on the system type (BC, VCC, and ESPNet).

Table 3: Average performance of the proposed model on 5 different runs (CMP-AE+wM+wF(AVG.)) against a control model (wM+wF (control model)). The control model is the same model without CMP-AE features. It is used to study the effect of the extra output layer.

	Utterance Level				System Level			
	MSE	SRCC	LCC	KTAU	MSE	SRCC	LCC	KTAU
CMP-AE+wM+wF (AVG.)	0.205	0.876	0.878	0.702	0.121	0.923	0.925	0.769
wM+wF (control model)	0.21	0.877	0.88	0.702	0.129	0.923	0.926	0.769

5. Discussion

The models NISQA Scratch, NISQA Pre-Trained, LDNet, CMP-AE perform similarly on the system-level performance. Only MOSA-Net shows slightly better results. A key observation is that CMP-AE shows almost the same results as NISQA Scratch with a network that is 40% smaller. This implies that pre-training with autoencoder and using temporal max pooling could replace the self-attention layer and temporal attention pooling on this data. This might be useful in applications where memory issues occur.

The results of fine-tuning the SSL models are aligned with findings from computer vision [21] and various speech tasks [22]. Even though fine-tuning the SSL models results in superior performance, we showed that the training set has a crucial role. We fine-tuned the wav2vec2_base model with natural speech and showed that the performance drops remarkably compared to all the other models.

The model CMP-AE+Wm+Wf is also composed of an extra layer compared to the wav2vec2_base baseline (Fig 1). This is necessary to map the combined features to a final predicted MOS score. To check if the better test set results reported in Table 2 are because of the CMP-AE features and not due to the extra layer we create a control model here called wM + wF. The control model is composed of a linear layer that maps the 769-dimensional feature space (wav2vec2_base features concatenated to the predicted MOS of the fine-tuned wav2vec2_base) to the final predicted MOS. So we discard the CNN features. In Table 3 we compare the control model against the average of 5 runs of CMP-AE+wM+Wf and show that the CNN features poorly contribute to improving the wav2vec2_base baseline. A possible reason could be that learning features with an SSL task from raw waveform shows greater flexibility than using hand-crafted features such as log Mel

spectrogram with supervised learning as shown in other audio tasks [22, 11]. So the CNN features do not capture new useful information. However we found that the extra layer with a MOS predicted in a previous training adds benefit. Further investigation is required to understand why adding an extra layer that takes the predicted MOS as input improves the performance.

Finally, we showed that the MOS predictors evaluated in this paper do not show the same performance on all the system types (Figure 1). ESPNet systems consistently show worse performance in all the MOS predictors while the best results are obtained on the VCC systems. It has been shown that ESPNet are the models exhibiting the highest subjective MOS while VCC systems show the lowest [18]. This suggests a possible cause of the performance drop could be related to the intrinsic properties of high-quality synthesised speech or due to some biases in the subjective MOS of high-quality speech.

6. Conclusions

In this paper, we compared deep learning-based MOS predictors for speech synthesis and evaluated modifications to certain networks. Using the VoiceMOS challenge dataset we found that fine-tuned SSL models perform remarkably better than other MOS predictors developed for natural speech but suffer when fine-tuned on natural speech. We showed that NISQA can be simplified using temporal max pooling instead of self-attention and temporal attention pooling. We showed that the system type has an impact on the performance of the non-SSL models with the best results obtained for VCC samples and worse performance obtained on BC and ESPNet samples.

In the future, we will extend the evaluation on the out-of-domain track and we will explore an analysis of network sizes since SSL networks are usually large. Finally, we will explore the cause concerning the influence of the system type on the performance.

7. Acknowledgements

This publication has emanated from research conducted with the financial support of Science Foundation Ireland (SFI) under Grant Number 17/RC-PhD/3483 and 17/RC/2289_P2. The work of EB was supported by a Turing Fellowship.

8. References

- [1] Y. Ning, S. He, Z. Wu, C. Xing, and L.-J. Zhang, "A review of deep learning based speech synthesis," *Applied Sciences*, vol. 9,

- no. 19, p. 4050, 2019.
- [2] B. Sisman, J. Yamagishi, S. King, and H. Li, "An overview of voice conversion and its challenges: From statistical modeling to deep learning," *IEEE/ACM Transactions on Audio, Speech, and Language Processing*, vol. 29, pp. 132–157, 2020.
 - [3] E. Cooper, W.-C. Huang, T. Toda, and J. Yamagishi, "Generalization ability of MOS prediction networks," *arXiv preprint arXiv:2110.02635*, 2021.
 - [4] P. Wagner, J. Beskow, S. Betz, J. Edlund, J. Gustafson, G. Eje Henter, S. Le Maguer, Z. Malisz, C. Székely, C. Tännander *et al.*, "Speech synthesis evaluation—state-of-the-art assessment and suggestion for a novel research program," in *Proceedings of the 10th Speech Synthesis Workshop (SSW10)*, 2019.
 - [5] B. Patton, Y. Agiomyrgiannakis, M. Terry, K. Wilson, R. A. Saurous, and D. Sculley, "AutoMOS: Learning a non-intrusive assessor of naturalness-of-speech," *NIPS 2016 End-to-end Learning for Speech and Audio Processing Workshop*, 2016.
 - [6] J. Williams, J. Rownicka, P. Oplustil, and S. King, "Comparison of speech representations for automatic quality estimation in multi-speaker text-to-speech synthesis," in *Proc. Odyssey 2020 The Speaker and Language Recognition Workshop*, 2020, pp. 222–229.
 - [7] C.-C. Lo, S.-W. Fu, W.-C. Huang, X. Wang, J. Yamagishi, Y. Tsao, and H.-M. Wang, "Mosnet: Deep learning-based objective assessment for voice conversion," *Proc. Interspeech 2019*, pp. 1541–1545, 2019.
 - [8] A. Ragano, E. Benetos, and A. Hines, "Development of a speech quality database under uncontrolled conditions," *Proc. Interspeech 2020*, pp. 4616–4620, 2020.
 - [9] W.-C. Huang, E. Cooper, J. Yamagishi, and T. Toda, "Ldnet: Unified listener dependent modeling in mos prediction for synthetic speech," *arXiv preprint arXiv:2110.09103*, 2021.
 - [10] A. Baevski, Y. Zhou, A. Mohamed, and M. Auli, "wav2vec 2.0: A framework for self-supervised learning of speech representations," *Advances in Neural Information Processing Systems*, vol. 33, pp. 12 449–12 460, 2020.
 - [11] M. Tagliasacchi, B. Gfeller, F. de Chaumont Quitry, and D. Roblek, "Pre-training audio representations with self-supervision," *IEEE Signal Processing Letters*, vol. 27, pp. 600–604, 2020.
 - [12] P.-H. Chi, P.-H. Chung, T.-H. Wu, C.-C. Hsieh, Y.-H. Chen, S.-W. Li, and H.-y. Lee, "Audio albert: A lite bert for self-supervised learning of audio representation," in *2021 IEEE Spoken Language Technology Workshop (SLT)*. IEEE, 2021, pp. 344–350.
 - [13] G. Mittag, B. Naderi, A. Chehadi, and S. Möller, "NISQA: A deep cnn-self-attention model for multidimensional speech quality prediction with crowdsourced datasets," *INTERSPEECH*, pp. 2127–2131, 2021.
 - [14] A. Ragano, E. Benetos, and A. Hines, "More for less: Non-intrusive speech quality assessment with limited annotations," in *2021 13th International Conference on Quality of Multimedia Experience (QoMEX)*. IEEE, 2021, pp. 103–108.
 - [15] M. H. Soni and H. A. Patil, "Novel deep autoencoder features for non-intrusive speech quality assessment," in *2016 24th European Signal Processing Conference (EUSIPCO)*. IEEE, 2016, pp. 2315–2319.
 - [16] H. Martinez, M. C. Farias, and A. Hines, "NAViDad: A no-reference audio-visual quality metric based on a deep autoencoder," in *2019 27th European Signal Processing Conference (EUSIPCO)*. IEEE, 2019, pp. 1–5.
 - [17] G. Mittag, R. Cutler, Y. Hosseinkashi, M. Revow, S. Srinivasan, N. Chande, and R. Aichner, "Dnn no-reference psth speech quality prediction," *Proc. Interspeech 2020*, pp. 2867–2871, 2020.
 - [18] E. Cooper and J. Yamagishi, "How do voices from past speech synthesis challenges compare today?" *Proceedings of the 11th ISCA Speech Synthesis Workshop, 2021.*, 2021.
 - [19] V. Panayotov, G. Chen, D. Povey, and S. Khudanpur, "Librispeech: an asr corpus based on public domain audio books," in *2015 IEEE international conference on acoustics, speech and signal processing (ICASSP)*. IEEE, 2015, pp. 5206–5210.
 - [20] R. E. Zezario, S.-W. Fu, F. Chen, C.-S. Fuh, H.-M. Wang, and Y. Tsao, "Deep learning-based non-intrusive multi-objective speech assessment model with cross-domain features," *arXiv preprint arXiv:2111.02363*, 2021.
 - [21] A. Newell and J. Deng, "How useful is self-supervised pretraining for visual tasks?" in *Proceedings of the IEEE/CVF Conference on Computer Vision and Pattern Recognition*, 2020, pp. 7345–7354.
 - [22] S. wen Yang, P.-H. Chi, Y.-S. Chuang, C.-I. J. Lai, K. Lakhotia, Y. Y. Lin, A. T. Liu, J. Shi, X. Chang, G.-T. Lin, T.-H. Huang, W.-C. Tseng, K. tik Lee, D.-R. Liu, Z. Huang, S. Dong, S.-W. Li, S. Watanabe, A. Mohamed, and H. yi Lee, "SUPERB: Speech Processing Universal PERFORMANCE Benchmark," in *Proc. Interspeech 2021*, 2021, pp. 1194–1198.